

ert

REPAIR OPERATION MANUAL



DISC BRAKE CALIPER



ER - 180/2/96



WHO WE ARE

Specialists with over 40 years of experience in manufacturing precision rubber parts, in particular brake parts.

Our quality is ensured by the ISO 9002 standard, we are market leaders and our products are exported to over 65 countries.



WHAT WE DO

We create repair kits for different hydraulic elements of the brake and the hydraulic clutch operator: master cylinders, wheel cylinders, caliper, clutch slave cylinder...

We provide our customer, **THE FREE GARAGE** with a wide range of kits covering from vehicles more than 20 years old to the newest models.

MARCA			i	∅ (mm.)	∅ (mm.)		VERSIÓN	PAÍS
ALFA ROMEO							1 2 3 4 5 6 7 8 9	
ALFA 1.300 GT-1.750-2.000								
BOMBA FRENO - MASTER CYLINDER - MAÎTRE CYLINDRE								
TODOS LOS TIPOS (ALL TYPES)		70>>		20,6	0	D1123	ATE-FAG	AMERICA
2		>>71		20,6	0	D1136	BONALDI	
PINZA DELANTERA - FRONT CALIPER - ETRIER AVANTE								
TODOS LOS TIPOS (ALL TYPES)				48	0	D4063	ATE-LUCAS	
PINZA TRASERA - REAR CALIPER - ETRIER ARRIERE								
TODOS LOS TIPOS (ALL TYPES)				38	0	D4066	ATE	
BOMBA EMBRAGUE - CLUTCH MASTER CYLINDER - ÉMETTEUR D'EMBRAYAGE								
TODOS LOS TIPOS (ALL TYPES)		70>>		17,5	0	D1141	ATE	
RECEPTOR EMBRAGUE - CLUTCH SLAVE CYLINDER - RECEPTEUR D'EMBRAYAGE								
1.750, 2.000		>>69		25,4	0	D3157	BREMBO	
TODOS LOS TIPOS (ALL TYPES)		70>>		25,4	0	D3158	ATE	

HOW WE COLLABORATE WITH YOU

Providing you with the following elements through our distributor:

- This manual, that will aid in a correct repair.
- The catalogue comes in both written and CD-ROM versions.
- A team of specialists who work to offer you the highest quality in all our products and services.

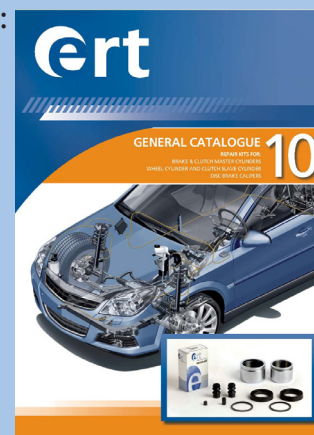

REPAIR KITS FOR BRAKE CALIPERS

This repair operation manual focuses on brake calipers.

The different repair kits for the brake calipers that Seinsa develops are:

- Piston Repair Kit:

Kit composed of one piston.

Named 150*-C (* is the kit number).



- Repair kit without piston:

Kit to repair the brake caliper composed of :
seals, boots, guide boots and clamps.



- Complete repair kit:

Complete brake caliper repair kit composed
of: seals, boots, guide boots, clamps and pis-
tons.

This kit is complete for one wheel.



KINDS OF CALIPERS

There are different kinds of calipers: front calipers and rear calipers.

The great majority of cars has the rear calipers with only one piston.

However, depending on the model of car, the front caliper can be designed with two, four, six even eight pistons.

WARNING!! Every time those brake pads are replaced, it is very important to replace the piston seal, a worn seal, impedes the piston's return when finished braking, producing quicker erosion of pads and annoying noises.

1. Remove the caliper and dismantle it if necessary to remove the piston.



2. Remove the boot and the piston using compressed air if necessary, being careful to place a wooden shim between the running board and the piston.

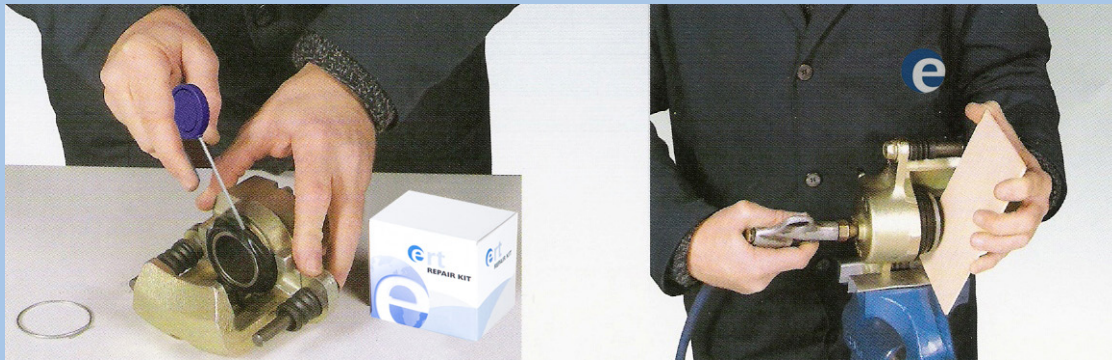

3. Remove the o-ring with a flexible blade with a rounded edge, or the Seinsa tool. Clean the inside of the caliper and the piston only with alcohol or brake fluid, ensuring the perfect cleanliness of the groove where the ring fits.



4. Before introducing the new o-ring in the sealing groove, lubricate it with special grease, Vaseline or brake fluid. Fit it in its place with your finger and check that it fits well throughout the entire the surface of the sealing groove.



5. Press to introduce the piston, prevent the piston from crossing the seal position, because in such a case it will damage the seal.

NOTE: There are two main types of caliper that require different procedures to assemble the piston and the boot:

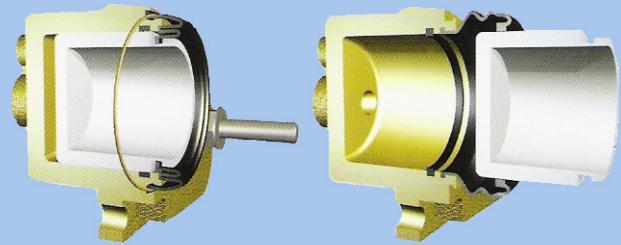
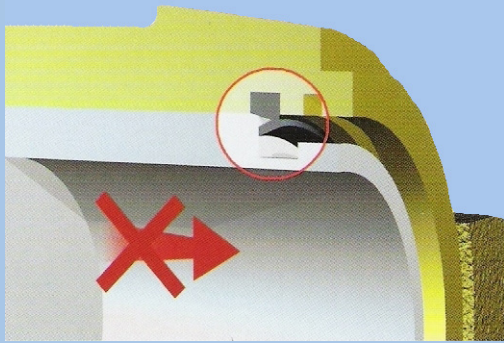

TYPE A

TYPE B

6. To assemble TYPE A: fit the boot in the piston groove and then introduce it into the caliper, then, put the boot in the sealing groove and fit the shim.

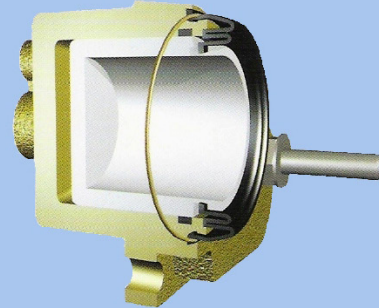
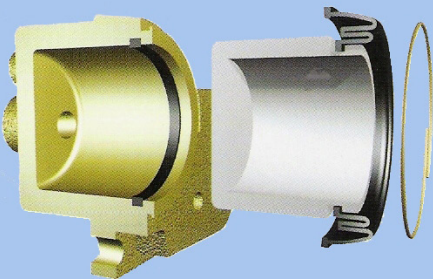

7. To assemble TYPE B: fit the boot in the piston (not in its groove), and introduce it in the sealing groove before fitting the piston.

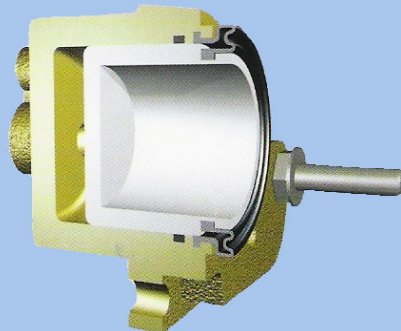
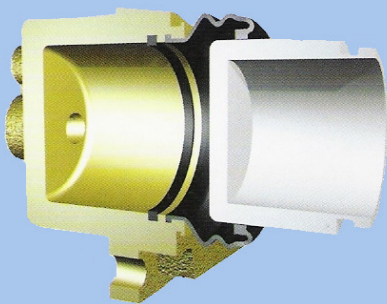

8. If the caliper has a movable part which slides on the guides, Seinsa recommends to clean and grease the guides, and then replace the guide boots even if the parts slide correctly.

YOU CAN SEE THE VIDEO DEMONSTRATIONS ON OUR WEBSITE
<http://www.ertcompany.com>

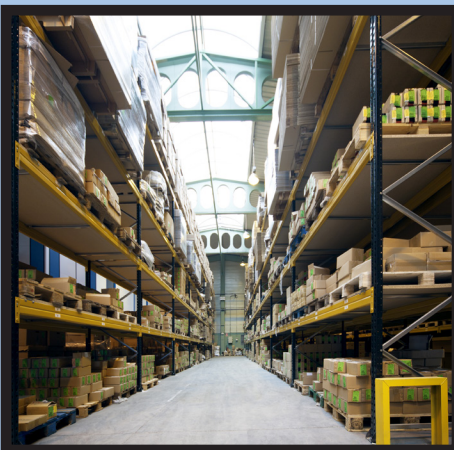

ERT

C/Elizguíbel s/n, 31638, Eugi (Navarra), SPAIN

Export Tel.: +34 948 304 060

Fax. +34 948 304 286

Export e-mail: export@ertcompany.com

<http://www.ertcompany.com>