

GASKETS



2011
2012

CATPA1001



Gaskets, Oil Seals and Cylinder Headbolts

Dichtungen, Wellendichtringe und
Zylinderkopfschrauben

Joints, Bagues d'étanchéité et Vis de culasse

Juntas, retenes de aceite y tornillos de culata

Uszczelki, uszczelnienia olejowe i śruby głowicowe

Прокладки, Сальники и Болты ГБЦ

حشيات رؤوس الأسطوانات و سدادات الزيت و مسامير رؤوس الأسطوانات

 **FEDERAL
MOGUL**







 **GLYCO**

 **GOETZE**

Niral

 **Payen**

			
<p>GASKETS</p> <ul style="list-style-type: none"> Full Set Head Set Conversion Set Without cylinder head gasket Without seals Without rocker gasket Without valve stem seals Left Right Upper Lower Inlet Exhaust Set <p>MISCELLANEOUS</p> <ul style="list-style-type: none"> Front Rear Inner Outer <p>HEADBOLT</p> <ul style="list-style-type: none"> Male hex Female hex Male star Female star Male torx Female torx Teeth hex Small hex 	<p>DICHTUNGEN</p> <ul style="list-style-type: none"> Vollsatz Kopfsatz Kurbelgehäusesatz Zylinderkopfdichtung nicht enthalten Ohne Öldichtungen Ohne Zylinderkopfdeckeldichtungen Ohne Ventilschaftdichtringe Links Rechts Oben Unten Einlaß Auslaß Satz <p>VERSCHIEDENES</p> <ul style="list-style-type: none"> Vorne Hinten Innen Außen <p>ZYLINDERKOPFSCHRAUBEN</p> <ul style="list-style-type: none"> Sechskant Innensechskant Vielzahn Innenvielzahn Außen Torx Innen Torx Innenvielzahn Sechskant mit angegossener Scheibe 	<p>JOINTS</p> <ul style="list-style-type: none"> Pochette complète Pochette rodage Pochette complément Joint de culasse non inclus Bagues d'étanchéité non inclus Joint de couvre culbuteurs non inclus Joints de queue de soupape non inclus Gauche Droite Supérieur Inférieur Admission Échappement Pochette <p>ARTICLES DIVERS</p> <ul style="list-style-type: none"> Avant Arrière Intérieur Extérieur <p>VIS DE CULASSE</p> <ul style="list-style-type: none"> Hexagonale Hexagonale type "Allen" Cannelée Cannelée intérieure/femelle Etoile "torx" mâle Etoile "torx" intérieure/femelle Cannelée intérieur Mâle hexagonale avec rondelle intégrée 	<p>JUNTAS</p> <ul style="list-style-type: none"> Juego Completo Conjunto de Cilindro Juego de Conversión Sin junta de culata Sin retenes Sin juntas de balancines Sin retenes de válvula Izquierda Derecha Superior Inferior Admisión Escape Juego <p>OTRAS PIEZAS</p> <ul style="list-style-type: none"> Delantero Trasero Interior Exterior <p>TORNILLOS</p> <ul style="list-style-type: none"> Hexagonal macho Hexagonal hembra Estrella macho Estrella hembra Torx macho Torx hembra Estrella hembra especial Hexagonal con arandela
<p>USZCZELKI</p> <ul style="list-style-type: none"> Kompletny zestaw Zestaw głowicowy - góra silnika Zestaw zamienny - dół silnika Bez uszczelki głowicowej Bez uszczelnień olejowych Bez uszczelki pod dekiel zaworów Bez uszczelnień zaworów Lewy/Lewa Prawy/Prawa Górny/Górna Dolny/Dolna Dolot Wydech Zestaw <p>RÓŻNE</p> <ul style="list-style-type: none"> Przedni Tylny Wewnętrzny Zewnętrzny <p>ŚRUBA GŁOWICOWA</p> <ul style="list-style-type: none"> Sześciokąt - męski Sześciokąt - żeński Gwiazda - męski Gwiazda - żeński Torx - męski Torx - żeński Sześciokąt - zębony Sześciokąt - mały 	<p>ПРОКЛАДКИ</p> <ul style="list-style-type: none"> Полный комплект Комплект прокладок ГБЦ Комплект для модернизации Без прокладки ГБЦ Без уплотнений Без прокладок рокеров Без маслосъемных колпачков Левый/Левая Правый/Правая Верхний/Верхняя Нижний/Нижняя Впускного Выпускного Комплект <p>РАЗНОЕ</p> <ul style="list-style-type: none"> Передний Задний Внутренний Внешний <p>БОЛТ ГБЦ</p> <ul style="list-style-type: none"> Шестигранник наружный Шестигранник внутренний "звездочка" наружная "звездочка" внутренняя "торкс" наружный "торкс" внутренний Зубчатый шестигранник Малый шестигранник 	<p>الحشيات</p> <ul style="list-style-type: none"> المجموعة الكاملة مجموعة الرأس مجموعة التحويل بدون حشية رأس الأسطوانة بدون السدادات بدون حشية القلب بدون سدادات ساق الصمام اليسرى اليمنى العلوية السفلية السحب العادم المجموعة <p>متنوعة</p> <ul style="list-style-type: none"> الأمامية الخلفية الداخلية الخارجية <p>مسمار الرأس</p> <ul style="list-style-type: none"> السداسي الذكر السداسي الأنثى نجمة ذكر نجمة أنثى النجمي الذكر النجمي الأنثى سداسي السنون سداسي صغير 	<p>USZCZELKI</p> <ul style="list-style-type: none"> Kompletny zestaw Zestaw głowicowy - góra silnika Zestaw zamienny - dół silnika Bez uszczelki głowicowej Bez uszczelnień olejowych Bez uszczelki pod dekiel zaworów Bez uszczelnień zaworów Lewy/Lewa Prawy/Prawa Górny/Górna Dolny/Dolna Dolot Wydech Zestaw <p>RÓŻNE</p> <ul style="list-style-type: none"> Przedni Tylny Wewnętrzny Zewnętrzny <p>ŚRUBA GŁOWICOWA</p> <ul style="list-style-type: none"> Sześciokąt - męski Sześciokąt - żeński Gwiazda - męski Gwiazda - żeński Torx - męski Torx - żeński Sześciokąt - zębony Sześciokąt - mały

CONTENTS



Zawartość	III
Payen - historia i obecność na świecie	IV
Zastosowania w kolejności producentów	V
Warunki i wymagania sprzedaży	VII
Najnowsze katalogi Federal-Mogul dotyczące części silnikowych i uszczelnień	VIII
System oznaczania części Payen	IX
Jak korzystać z tego katalogu	XIV-XV
Poradnik montażowy uszczelki i śrub głowicowych	XXII
Certyfikat BER	XXV
PEWNOŚĆ W KAŻDYCH WARUNKACH: Efekt jakości i innowacyjności marki Payen®	XXXIV-XXXV
Lista nowych części	XL - XLVI
Zastosowania w kolejności producentów	2 - 1555
Numeryczna lista części	1556 - 1617
Lista zamienników z numerów OE na Payen	1618 - 1670
Lista zamienników z numerów Goetze na Payen	1671 - 1685
Śruba głowicowa	1686 - 1690
Notatki techniczne	1704 - 1713



المحتويات	III
تاريخ Payen وتواجدها العالمي	IV
التطبيقات حسب جهة التصنيع	V
بنود وشروط المبيعات	VII
أحدث كتالوجات Federal-Mogul للمحركات ومنتجات منع التسرب	VIII
نظام ترقيم قطع Payen	IX
كيفية استخدام هذا الكتالوج	XVI - XVII
دليل تركيب حشية رأس الأسطوانة والمسامير	XXIV
شهادة BER	XXV
جودة الأداء حتى في أصعب الظروف: تاريخ من الجودة والابتكار يتمثل في ماركة Payen®	XXXVIII - XXXIX
قائمة القطع الجديدة	XL - XLVI
التطبيقات حسب جهة التصنيع	2 - 1555
قائمة القطع المرقمة	1556 - 1617
تبديل المعدات الأصلية - Payen	1618 - 1670
تبديل Goetze -> Payen	1671 - 1685
مسمار الرأس	1686 - 1690
ملاحظات فنية	1704 - 1713



Содержание	III
Payen: история и присутствие на мировом рынке	IV
Модели автомобилей, сортировка по производителю	V
Условия сотрудничества	VII
Новейшие каталоги Federal-Mogul по деталям двигателя и уплотнениям	VIII
Структура нумерации деталей Payen	IX
Как пользоваться каталогом	XIV-XV
Руководство по установке прокладки головки блока цилиндров и болтов	XXIII
Сертификат BER	XXV
Эффективность под давлением: наследие качества и инноваций - Payen®	XXXVI-XXXVII
Список новой продукции	XL - XLVI
Модели автомобилей, сортировка по производителю	2 - 1555
Список номеров деталей	1556 - 1617
Взаимозаменяемость OE → Payen	1618 - 1670
Взаимозаменяемость Goetze → Payen	1671 - 1685
Болты ГБЦ	1686 - 1690
Технические примечания	1704 - 1713

ЗАМЕНА ПРОКЛАДКИ ГОЛОВКИ БЛОКА ЦИЛИНДРОВ

1. Очистите поверхности головки и блока от грязи, масла, охлаждающей жидкости и остатков старого уплотнения. Грязь на поверхности может стать причиной утечки, что приведет к выходу из строя новой прокладки. Не кладите чистые головки лицевой стороной вниз на верстак или на пол, где на них может налипнуть грязь.
2. Если для удаления старой прокладки используется скребок, соблюдайте особую осторожность, чтобы не повредить поверхности головки и блока. Это особенно важно в отношении алюминиевых поверхностей, которые можно легко повредить.
3. Убедитесь, что деформация поверхностей головки и блока не превышает 0,05 мм и что покрытие поверхности отвечает рекомендациям производителя двигателя.
4. Убедитесь, что все отверстия под болты очищены от грязи, охлаждающей жидкости и масла. Не допускайте чрезмерного применения смазок, особенно в отверстиях для потайных болтов. Это может привести к отрицательному влиянию гидравлических пробок на возникающие зажимные усилия и даже растрескиванию блока.
5. На дизельных двигателях проверьте высоту поршня над блоком, чтобы убедиться в правильной толщине используемой прокладки.

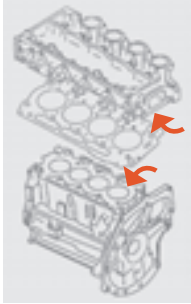

6. Не наносите какой-либо дополнительный герметик на прокладку головки блока цилиндров. Это может привести к выдавливанию прокладки и выходу ее из строя. Кроме того, герметик может быть выдавлен в масляные каналы, что вызовет закупорку и дальнейший выход двигателя из строя. Однако могут быть некоторые места, в которых производитель двигателя может рекомендовать использовать герметик — например, в передней крышке двигателя.
7. Перед установкой головки блока цилиндров убедитесь, что прокладка установлена нужной стороной вверх, правильно расположена на двигателе и, если применимо, установлена на шпильки.

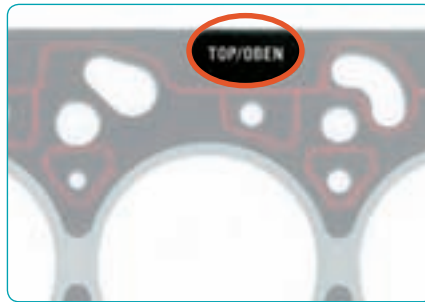

8. Осмотрите все болты головки на предмет повреждений, проверьте их длину и чистоту. Если в двигателе применяются натяжные болты (удлиняющиеся при затяжке), используйте новые болты согласно рекомендациям производителя двигателя.
9. Слегка смажьте резьбу и нижние поверхности головок болтов. Затяните все болты от руки; если имеются болты разной длины, убедитесь, что они используются в правильных точках. Затяните болты головки в последовательности, рекомендованной производителем двигателя. Для обеспечения точности используйте угломер там, где это требуется.

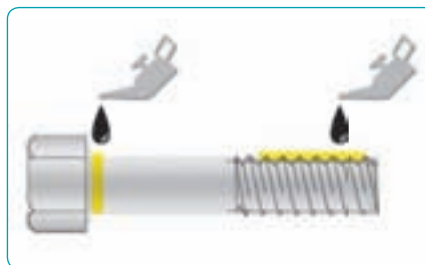

10. Если рекомендуется выполнить повторную затяжку, запустите двигатель на 20 минут. (Двигатели с алюминиевыми головками блока цилиндров перед повторной затяжкой необходимо охладить до комнатной температуры).

БОЛТЫ ГБЦ РЕКОМЕНДАЦИИ ПО ЗАТЯЖКЕ

- Осмотрите болты и отверстия на предмет отсутствия загрязнений, повреждений и правильной длины/глубины.
- Убедитесь, что в отверстиях под потайные болты нет мусора.
- Замените натяжные болты в соответствии с инструкциями производителя двигателя.
- Избегайте нанесения чрезмерного количества смазки, герметика или клея на резьбу болтов и в отверстия потайных болтов, чтобы уменьшить риск гидравлической пробки и неправильного момента затяжки.
- Убедитесь, что поверхности стыка чистые и не замаслены.
- Затяните болты в рекомендованной последовательности.
- Прекратите затягивать динамометрический ключ после щелчка!
- Если необходимо, используйте угломер.
- Регулярно выполняйте калибровку динамометрического ключа - особенно если его роняли!

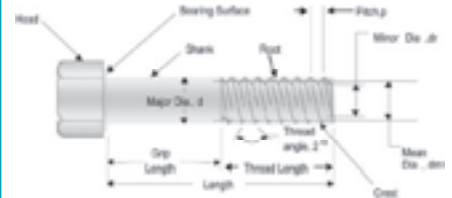

Шестигранная головка наружная



Шестигранная головка внутренняя



Наружная головка TORX



Внутренняя головка TORX



Наружная головка-звездочка



Внутренняя головка-звездочка



Шестигранная зубчатая головка



Малая шестигранная головка

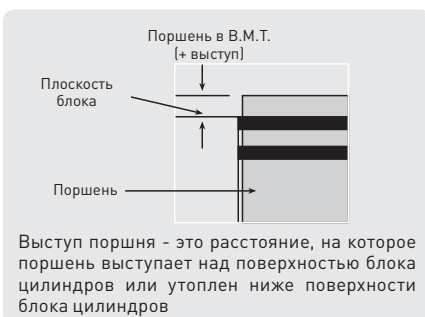

Выступ поршня - это расстояние, на которое поршень выступает над поверхностью блока цилиндров или утоплен ниже поверхности блока цилиндров

Выступ + - верх головки поршня над поверхностью блока цилиндров
Выступ - - верх головки поршня ниже поверхности блока цилиндров
 Обе величины измеряются, когда поршень находится в В.М.Т. (верхней мертвой точке)

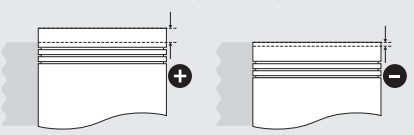

ЭФФЕКТИВНОСТЬ ПОД ДАВЛЕНИЕМ: НАСЛЕДИЕ КАЧЕСТВА И ИННОВАЦИЙ - PUYEN®

Инновации — двигатель автомобильной индустрии. Любой компонент современного легкового автомобиля или мощного коммерческого двигателя является результатом непрерывных поисков конструкторов и совершенствования производства. Тем не менее, немногие продукты изменились столь кардинально и столь инновационно, как уплотнительные элементы.

Когда речь заходит об инновационном дизайне прокладок, которые легко оставляют всех конкурентов позади как на рынке оригинального оборудования, так и на рынке запчастей, марка Puyen компании Federal-Mogul Corporation заслуженно занимает ведущее место.

Federal-Mogul – это ведущий мировой производитель прокладок для головок блока цилиндров и уплотнительных элементов оригинального оборудования. Лидерство на рынке оригинального оборудования означает, что каждая прокладка марки Puyen представляет собой результат новейших инновационных конструкторских разработок поистине мирового класса и внимательного изучения потребностей современных двигателей и производственных процессов, что гарантирует непревзойденное качество и эффективность.

Ассортимент продукции Puyen разрабатывается в четырех международных научных центрах, оснащенных новейшими технологиями и системами - это позволяет обеспечить сохранение и укрепление лидирующих позиций на рынке за счет предложения превосходных решений в сфере уплотнений.

200 ученых и инженеров работают над каждым элементом компонентов уплотнителей – от рецептуры материала до физического дизайна, также используются 26 испытательных стендов - для легких автомобильных и мощных коммерческих двигателей. Все это позволяет компании Federal-Mogul и марке Puyen обеспечивать идеальное решение для любой сложной задачи с использованием уплотнений.

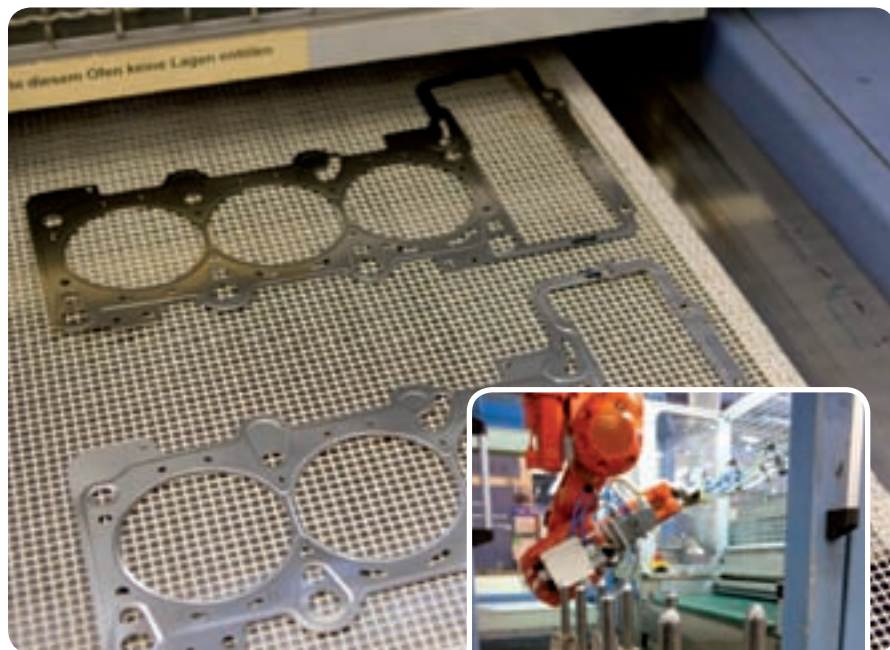

ЭФФЕКТИВНОСТЬ НА РЫНКЕ

Продукты Puyen производства Federal-Mogul «эффективны под давлением» самой требовательной бизнес-среды в мире: на рынке двигателей для легких и коммерческих автомобилей. Уникальная способность Federal-Mogul предлагать инновационные, сверхнадежные технологии уплотнений позволила построить прочные деловые связи с ведущими мировыми производителями, включая Audi, BMW, Chrysler, Citroen, Deutz, Fiat, Ford, Honda, Land Rover, MAN, Mercedes-Benz, Opel/Vauxhall, Peugeot, Renault, Toyota и Volkswagen.

Центр Federal-Mogul Sealing Systems в городе Хердорф (Германия) играет важную роль в обслуживании тысяч покупателей из числа производителей оригинального оборудования и запасных частей. Это суперсовременное предприятие выпустило миллионы инновационных продуктов, в которых использовались технологии HTA (высокотемпературные сплавы), MLS (многоослойная сталь) и LASPOT. Предприятие в Хердорфе прекрасно оснащено для решения проблем 21-го века: это обеспечивает лидерство Federal-Mogul в качестве и системах управления. В качестве признания этих и других достижений, компания Federal-Mogul Sealing Systems GmbH удостоилась престижной награды "TOP 100" Министерства экономики Германии.

ОТ КОНЦЕПЦИИ К ВОПЛОЩЕНИЮ: ЭФФЕКТИВНОСТЬ В КАЖДОЙ ДЕТАЛИ

Одной из самых сильных сторон команды Federal-Mogul из Хердорфа является приверженность постоянному совершенствованию и стремление изучать и проверять новые идеи – и при этом не упускать из виду потребностей каждого клиента. Используя инновационные материалы и конструкции в сочетании с новейшими производственными процессами, Federal-Mogul марка Puyen обеспечивают спрос в самых сложных областях и решают любые бизнес-задачи.

Такое жесткое следование принципам качества и инноваций проявляется в каждом продукте Puyen. В качестве примера мож-



ПРОКЛАДКИ LEM (LIQUID ELASTOMER MOULDING - ЛИТЬЕ ИЗ ЖИДКОГО ЭЛАСТОМЕРА)

Прокладки LEM производства Federal-Mogul прекрасно зарекомендовали себя при решении сложных задач уплотнения, встающих перед производителями комплектного оборудования, в частности, в шарнирах, требующих значительной гибкости. Выпущено более 40 миллионов прокладок LEM, которые используются компаниями Audi, BMW (легковые автомобили и мотоциклы), Brilliance, Citroen, Cummins, Dacia, Deutz, Fiat, Ford, Harley-Davidson, Iveco, Jaguar, Mercedes-Benz, Lancia, Nissan, Opel, Peugeot, Renault, Seat, Skoda, Volvo и Volkswagen. Прокладки LEM широко представлены в ассортименте продукции Payen.

Эта технология прекрасно подходит для рынка запасных частей. Рельефные уплотнительные валики на прокладках LEM марки Payen компенсируют деформацию фланцев на 30% большую, чем продукция конкурентов. Это особенно важно, поскольку проектировщики двигателей применяют облегченные фланцы и сниженные нагрузки на болты. Технология LEM пригодится и в завтрашних топливных элементах – и данные решения в области уплотнений войдут в ассортимент продукции Payen по мере развития этого многообещающего рынка.

но привести прокладку головки блока цилиндров LASPOT, разработанную инженерами Federal-Mogul по запросам потребителей. Требовалось создать конструкцию, в которой прокладка выполняет основную уплотнительную функцию в областях применения с повышенным давлением сгорания. В каждой прокладке LASPOT используется новейшая технология, обеспечивая потребности самых требовательных дизельных двигателей. К другим отличительным чертам этих прокладок можно отнести функциональные слои, изготавливаемые из пружинной нержавеющей стали с каплеобразными выпуклостями разного размера, расположенными в соответствии с «закрытой» концепцией. Такой подход обеспечивает надежное уплотнение вдоль линейной зоны герметизации. Чтобы обеспечить исключительное микроуплотнение, все слои покрыты высококачественным, стабильным фторэластомером.

ПРОКЛАДКИ MLS (MULTI-LAYER STEEL - МНОГОСЛОЙНАЯ СТАЛЬ)

Компания Federal-Mogul является неоспоримым лидером в сфере технологий изготовления прокладок ГБЦ из многослойной стали уже почти 20 лет. Компания выпустила на предприятии в Хердорфе более 43 миллионов прокладок MLS для головок блоков цилиндров, при этом завод является также ведущим поставщиком для рынка запасных частей. Среди наиболее популярных прокладок MLS для головок блоков

цилиндров оригинального оборудования, выпускаемых в Хердорфе, можно упомянуть AC5300 (BMW) и AB5140 (Opel). Эти же модели прокладок поставляются на вторичный рынок под маркой Payen. Еще один хороший пример - модель AE5200 (Renault / Nissan). Такой успех в сегменте оригинального оборудования обусловлен, в частности, большим опытом Federal-Mogul в организации технологического процесса и независимостью в области технологий продуктов и инструментов. Инженеры Federal-Mogul находят и применяют наилучшие идеи и технологии, чтобы создавать оптимальные продукты для каждого двигателя - будь то прецизионная разработка и производство инструментов для проработки рельефа, выполнение самых жестких требований к покрытию прокладок или разработка высокоэффективного сварочного оборудования.

ОТМЕЧЕННЫЕ НАГРАДАМИ ПРОКЛАДКИ НТА (HIGH TEMPERATURE ALLOY - ВЫСОКОТЕМПЕРАТУРНЫЙ СПЛАВ)

Потребность в повышении мощности небольших двигателей привела к увеличению температуры отработанных газов, что может отрицательно сказаться на прокладках системы выпуска. Чтобы помочь производителям двигателей решить эту проблему, компания Federal-Mogul разработала серию новых материалов и конструкций ГБЦ. Одно из таких решений – прокладка НТА (высокотемпературный сплав) – на порядок улучшает уплотнение отработавших газов.

Эта новая технология, удостоенная престижной награды Automotive News PACE Award for Innovation 2007, исключительно устойчива к тепловой деформации и способна выдерживать температуры до 1000°C. Инновационного прорыва компания Federal-Mogul добилась исключительно за счет огромного опыта в материаловедении, особенно в области металлов, покрытий и химии поверхностей. Клиенты Federal-Mogul на вторичном рынке уже получают огромные преимущества от технологии НТА за счет ее внедрения в производство деталей под маркой Payen.

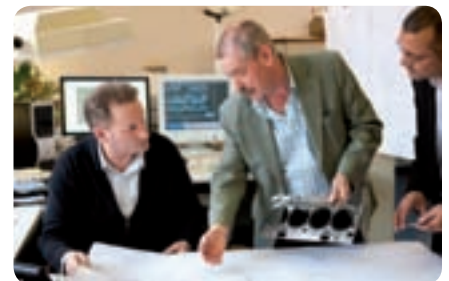





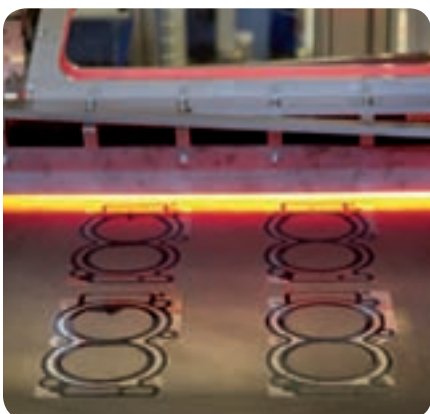



РАУЕН ЭФФЕКТИВНОСТЬ ПОД ДАВЛЕНИЕМ





Уплотнительные элементы никогда ранее не были столь важны для повышения общей мощности и надежности автомобильных двигателей. Увеличение давления и температуры в цилиндрах, а также снижение массы двигателя превратили искусство уплотнения в одну из самых сложных и требовательных областей проектирования двигателя. Непревзойденный опыт на рынках как оригинального оборудования, так и запасных частей, позволяет изделиям под маркой Payen ЭФФЕКТИВНОСТЬ ПОД ДАВЛЕНИЕМ практически в любом уплотнении автомобильного двигателя. Другими словами, компания Federal-Mogul марка Payen – это новый стандарт в технологиях уплотнения.



NEW PARTS LIST









Liste der Neuaufnahmen • Liste des nouvelles références
Lista de nuevas referencias









 	 	 	 
ALFA ROMEO	BEDFORD	BMW	CITROËN
AG9580 26, 36, 44	BJ170 112	JR5046 125, 127, 145, 171	AH5080 248, 256
FN307 8, 10	BMW	KK5520 131, 133, 135, 137, 141, 147, 149, 151, 157, 161, 171, 173	AH5090 248, 256
HL5030 13, 15, 17, 19, 21, 23, 25, 29, 39, 41, 43	AC5470 120, 122, 124, 128, 132, 166, 172	KK5682 131, 137, 147, 149, 151	AH5100 248, 256
HL5031 13, 15, 17, 19, 23, 25, 31	AG9290 120, 138, 142, 152, 160, 162, 168, 174	KK5684 127	AH5110 248, 256
HR5095 19, 23, 25, 27, 39	AG9540 134, 144, 168, 172	NA5263 121, 123, 125, 127, 129, 131, 133, 135, 137, 139, 141, 145, 147, 149, 151, 153, 155, 157, 159, 161, 163, 165, 167, 169, 171, 173, 175	BR510 216, 220, 222, 224, 244, 258, 262, 264, 274, 280, 282
JD5868 27, 37, 45	AG9550 134, 144, 168, 172	NA5267 167	CC5011 236, 238, 242, 244, 252, 260, 266, 278
JM7055 19, 23, 25, 27, 39	CC5441 120, 122	NB792 149, 155, 157, 159, 161, 163, 165	CD5130 224, 228, 232, 270
KG5337 27, 37, 45	CG9000 140, 142, 152, 154, 156, 162, 168, 170	NC015 123, 125, 133	CD5140 216, 232, 234, 272
NF833 35, 37	CG9540 120, 134, 138, 142, 144, 152, 160, 162, 168, 172, 174	CHEVROLET	CD5490 236, 238
AUDI	EG9000 140, 142, 152, 154, 156, 162, 168	AG9580 178, 180	CD5500 234, 236, 238, 252
AG9600 70, 78	EG9540 120, 134, 138, 142, 144, 152, 160, 162, 168, 172, 174	AG9590 180	CG9030 228, 230, 232
AG9610 72, 100	HA5024 121, 123, 125, 129, 133, 167, 173	CD5691 178, 180	CG9310 224
AG9630 70, 78	HM5278 135, 145, 169, 173	CG9580 178, 180	CG9720 268, 270
BZ960 78, 86	JD189 123, 125, 145	CG9590 180	CG9740 268, 270
CC5223 72	JD239 131, 133, 137, 147, 149, 151, 171	ED5690 178, 180	CG9750 238
CC5960 80, 86, 88, 90, 91	JD5858 123, 125, 127, 171	FD5690 178, 180	CH5040 236, 238
CG8850 68	JD5864 121, 135, 139, 143, 145, 153, 161, 163, 169, 171, 173, 175	JD5868 179, 181	CH5060 236, 238
CG9600 70, 78	JD5909 121, 123, 129, 135, 139, 143, 145, 153, 161, 163, 169, 173, 175	JD5869 181	ED5490 236, 238
CG9610 72, 100	JD5916 131, 133, 135, 137, 141, 143, 147, 149, 151, 157, 161, 163, 169, 171, 173, 175	JD5870 181	ED5500 234, 236, 238, 252
EF5380 68, 70, 72, 78, 84	JE138 53, 59, 65, 95	KG5337 179, 181	EG9030 228, 230, 232
EG9600 70	JE5075 77, 79, 83, 85	CHRYSLER	EG9310 224
HL5020 51, 53, 55, 57, 59, 61, 63, 73, 75, 77, 79, 85, 91, 93, 95, 97	JE5076 53	AG9660 190	EG9710 268, 270
HL5034 67, 69, 73, 77, 79, 83, 85	JF205 69	AG9670 190	EG9750 238
HL5040 69, 73, 75, 77, 79, 85, 101	JF211 67	AG9680 190	HA5029 225, 229, 233, 271
JD327 55, 57, 61, 63, 67, 87, 93, 99	JH5117 67, 69, 83, 101	CG9660 190	HA5030 217, 233, 235, 273
JD603 55, 63, 65, 87, 97, 99	JH5118 57, 81, 89, 91, 93, 99	EG9660 190	HA5031 217, 233, 235, 273
JD5851 81, 87, 89, 90, 91	JM7030 79, 85	FG9660 190	HA5032 217, 229, 233, 273
JD5872 81, 89, 91, 99	JM7031 73	JD5826 185, 187	HL5010 223, 225, 227, 231, 243, 245, 247, 253, 255, 261, 265, 267, 269, 271, 275, 281, 283
JD5873 71, 79	JM7045 73, 101	JD5827 185, 187	HL5011 213, 215, 217, 219, 221, 227, 229, 231, 257, 259, 271, 273, 279, 281
JD5874 73, 101	JM7046 81, 89, 91, 99	JD5875 191	HL5012 217, 219, 229, 241, 243, 245, 247, 251, 253, 255, 261, 265, 267, 273, 275, 277, 281, 283
JE138 53, 59, 65, 95	JM7047 81, 89, 91, 99	JM7049 191	HL5016 219, 235, 237, 239, 243, 245, 247, 253, 257, 261, 267, 279
JE5075 77, 79, 83, 85	JN438 55, 57, 59, 61, 63, 65, 67, 99	CITROËN	HL5019 217, 221, 223, 225, 245, 247, 249, 255, 259, 261, 263, 265, 267, 269, 275, 277, 281, 283, 285
JE5076 53	JR5044 91	AD5700 212, 214, 216, 218, 220, 226, 228, 230, 254, 258, 270, 278, 280	HL5022 231, 241
JF205 69	JR5041 127	AG9030 228, 230, 232	HL5027 249, 257, 271
JF211 67	JR5042 127	AG9310 224	HL5033 217, 225, 233, 235, 273
JH5117 67, 69, 83, 101	JR5044 131, 133, 135, 137, 141, 147, 149, 151, 157, 161, 171, 173	AG9710 268, 270	HL5037 235, 237
JH5118 57, 81, 89, 91, 93, 99		AG9720 268, 270	HL5038 217, 228, 229, 233, 259, 273
JM7030 79, 85		AG9730 268, 270	
JM7031 73		AG9740 268, 270	
JM7045 73, 101		AG9750 238	
JM7046 81, 89, 91, 99		AH5040 236, 238	
JM7047 81, 89, 91, 99		AH5050 236, 238	
JM7048 71, 79		AH5060 236, 238	
JN438 55, 57, 59, 61, 63, 65, 67, 99		AH5070 236, 238	
JR5044 91			
NA5263 91			
NA5278 51, 53, 61, 65, 71, 77, 79, 85			

 CITROËN	 DAIHATSU	 FORD	 HYUNDAI
HM5289 235, 237, 239, 253	JD5863 305, 309	AG7810 446, 450	CG7910 502, 506, 508
JD5830 217, 233, 235, 273	JM7042 305, 309	AG7820 446, 450	CG8060 502, 506
JD5845 225	FIAT	AG9560 432, 436, 440	CG8291 502
JD5846 225	AG9580 330	CB5120 426, 436	FG7910 502, 506, 508
JD5863 225	AH5040 400	CB5132 428, 440	FG8060 502, 506
JD5878 269, 271	AH5050 400	CD5130 430, 440	FG8291 502, 512
JD5879 269, 271	AH5060 400	CD5140 432, 438, 440	GY735 502, 506
JD5880 269, 271	AH5070 400	CD5500 438, 442, 468	HM5250 503, 507, 509
JD5881 235, 237, 239, 253	BP300 404, 406	CG5030 444	JD5899 503
JD5882 229, 231, 233	BR510 396	CG7810 446, 450	JD5900 503, 507
JD5883 239	CD5490 400	CG9560 436	INFINITI
JD5906 237, 239	CD5500 378, 396	EB5120 426, 428, 432, 436, 440	CG5882 516
JD5907 237, 239	CD5810 316, 332, 350, 352, 360,	ED5500 438, 442, 468	ISUZU
JE5069 237, 239	366, 370	HA5029 431, 441	AB5781 528
JE5070 237, 239	CD5820 332, 350, 352, 386	HA5030 433, 439, 441	CG5781 528
JE5071 237, 239	CH5040 400	HA5031 433, 439, 441	IVECO
JE5072 215, 217, 229, 231, 233,	CH5060 400	HL5018 421, 423, 425, 435, 437,	NF833 541
255, 259, 263, 271, 273,	ED5490 400	449, 455, 457, 465	JEEP
281	ED5500 378, 396	HL5033 431, 433, 438, 439, 441	AG9690 568
JH5107 217, 228, 229, 233, 273	ED5810 316, 332, 350, 352, 360,	HM5289 439, 443, 469	BZ780 566
JM5141 237, 239	366, 370	JD5830 433, 439, 441	CD5720 566
JM7035 217, 229, 233, 273	ED5820 332, 350, 352, 386	JD5865 433, 437, 439, 441	CG9690 568
JM7042 225	FD5810 316, 332, 350, 352, 360,	JD5866 427, 429, 433, 437, 441	DZ630 566
JM7051 229, 231, 233	366, 370	JD5881 439, 443, 469	EG9690 568
JM7052 229, 231, 233	FD5820 332, 350, 352, 386	JM7045 445	EZ630 566
DACIA	HL5010 339, 379, 397, 401	KA5021 429, 445	HL5014 565
EE5200 286	HL5016 341, 381, 399, 401	KS696 445, 459, 461, 467	HM5274 567
HL5026 287	HL5019 339, 397, 399, 401	HONDA	JD5876 569
JD5393 287	HL5024 327, 359, 361, 363, 365,	AG7860 496	JD5877 569
DAEWOO	367, 369, 381, 383, 387,	AG7870 496	JH5106 569
CG7990 290, 294	403	AG7900 488	JM5286 565, 567, 569
CG8000 290, 292, 296	HL5028 391, 395, 397	AG8130 490, 494	JM7028 567
ED5690 294, 298	HL5030 319, 321, 323, 325, 327,	AG9180 482, 494	JM7050 569
ES260 292	355, 357, 371, 385, 387	AG9840 490	JR5044 565
FD5690 294, 298	HL5031 319, 321, 323, 325, 333,	AG9850 490	KIA
FG7990 290, 294	335, 353, 355, 357, 359,	AG9860 490	AG9870 576
FG8000 290, 292, 296	361, 371, 385, 387	CG9180 482, 494	AG9880 576
HR5092 291, 293, 295, 297	HL5032 345, 347	DV021 496	AG9890 576
JD169 293, 295	HM5289 379, 397	EG5810 478, 498	AG9900 574
JD450 295, 297	HR5095 325, 329, 385	FG5760 496	AG9910 572
KJ779 293, 295	JD5868 331	FG5761 480	CG8261 576
KK5683 293, 295	JD5881 379, 397	FG7860 496	CG9870 576
PA565 291, 293, 295, 297	JD5906 401	FG7960 494	CG9900 574
DAIHATSU	JD5907 401	FG8130 490, 494	CG9910 572
AG7970 304, 306	JE5069 401	FG8131 490, 492, 494, 498	FG8060 574
AG9310 304, 308	JE5070 401	GV021 496	LADA
AG9830 302, 304, 306, 308, 310	JE5071 401	HL5010 491	HL5010 579
CG5920 308	JM5141 399, 401	HL5034 485	PA565 579
CG7970 304, 306	JM7055 325, 329, 385	HM5246 493	LANCIA
CG9310 304, 308	KG5337 331	HM5247 497	CD5490 596
CG9830 302, 304, 306, 308, 310	NB633 317, 327, 349, 363, 365,	HM5249 497	CD5500 596
EG9310 304, 308	401	JM5300 495	CD5810 594, 604
JD5845 305, 309	NF833 331, 335, 341, 343		CD5820 594
JD5846 305, 309			ED5490 596

NEW PARTS LIST





Liste der Neuaufnahmen • Liste des nouvelles références
Lista de nuevas referencias





 	 	 	 
LANCIA	MERCEDES-BENZ	MITSUBISHI	NISSAN
ED5500 596	CD5720 674, 678, 688, 696, 700, 712, 713	AG9120 768, 770	JD5891 787, 795, 811, 823
ED5810 594, 604	CG8500 666	AG9130 746, 750, 762, 770	JD5892 787, 795, 811, 823
ED5820 594	CG8501 666, 668	AG9150 750	JH5109 795, 799, 801
FD5810 594, 604	CG8790 668, 676, 680, 708	AG9920 742, 758	JM7054 795, 799, 801
FD5820 594, 604	CH5010 674, 678, 680, 690, 700, 702	CF5500 750	KK5643 795, 799, 801
HL5016 597, 607	ED5720 674, 678, 688, 696, 700, 712	CG8080 740, 754, 766, 768	OPEL
HL5024 601, 603, 605	HL196 687, 689, 703, 705	CG9130 746, 750, 762, 770	AA5560 840, 841
HL5030 591, 593, 595	HM5274 675, 679, 689, 697, 701, 712, 713	CG9150 750	AG9570 842, 882, 896
HL5031 585, 591, 593, 595, 601, 603	HR754 689, 703, 705	EG5220 766	AG9580 844, 882, 890, 896
HM5289 597	JB162 665, 681, 687, 697, 699, 715, 717, 719	EG6270 746, 750, 762	AG9590 880, 892, 896
JD5881 597	JD169 675, 677, 689, 691, 693, 695, 699, 703, 705, 707	FF5490 764, 766	AG9770 882, 892
JM5141 597, 607	JD297 689, 697, 715, 717	FG7690 742, 754	AG9780 882, 892
LEXUS	JD478 693	HL5017 741, 769	AG9790 882, 892
AG9990 618	JD5835 669, 677, 681, 709	HL5017 741, 769	AG9800 882, 892
CF5030 618	JD5902 675, 679, 681, 691, 701, 703	JD5871 743	AG9810 882, 892
FF5030 618	JE5067 675, 679, 681, 691	JD5905 743, 759	AG9820 882, 892
HM5243 619	JE5068 675, 679, 681, 691	JM5290 749, 759, 763	AG9820 882, 892
LEYLAND / LDV	JH5113 695, 705, 707	JM5291 749, 759, 763	AH5030 828, 832, 848, 850, 852, 854, 868, 882
EG5260 626	JJ491 689, 691, 693, 699, 701, 703, 705, 707	JM7031 751, 763	BJ170 858, 868, 870, 876, 878
MAZDA	JM7028 675, 679, 689, 697, 701, 712, 713	JM7039 751	CD5810 846, 868
AG9560 634, 652	JR5040 675, 677, 689, 691, 693, 695, 699, 701, 703, 705, 707	JM7041 747, 751, 763	CD5820 832, 852
CB5120 634, 650	KG664 669, 677	NISSAN	CE5950 828, 832, 848
CB5132 634, 652	KK5683 665, 671, 675, 677, 681, 683, 689, 691, 693, 695, 699, 701, 703, 705, 707, 711, 713, 715, 717, 719, 721, 723	AB5690 782, 784, 786, 792, 808, 812, 818	CG9570 842, 882, 896
CD5130 634	NA5264 689	AG7810 782	CG9580 844, 882, 890, 896
CD5140 634	NA5268 695, 705, 707	AG7820 782	CG9590 880, 892, 896
CG7850 652	MINI	AG7880 792, 798	CG9770 882, 892
CG8150 658	AG7600 736	AG9930 822	CH5030 828, 832, 848, 850, 852, 854, 868, 882
CG8170 634	AG7610 736	AG9940 822	CH5031 828, 832, 850
CG8190 636, 654	AG7620 736	AG9950 822	DN042 860
EB5120 634, 650, 652	AG7620 736	AG9960 822	DY260 844, 890
EG5130 646	AG7620 736	AG9970 822	EC102 858
FG5130 646	AG7620 736	AG9980 822	ED5810 846, 868
FG7850 640	AG7620 736	CB5611 784, 786, 792, 808, 812, 818	ED5820 832, 852
FG8170 634	AG7620 736	CB5630 784, 786, 806, 816	EG9570 842, 882, 896
FG8190 636, 654	AG7620 736	CF5600 802	EG9770 882, 892
GS953 644	AG7620 736	CG5882 784, 790, 800	ES260 832, 834, 836, 838, 846, 848, 854, 862
HA5029 635	AG7620 736	CG7810 782	FD5810 846, 868
HA5030 635	AG7620 736	CG7880 792, 798	FD5820 852
HA5031 635	AG7620 736	DV311 780, 784, 790, 792, 796, 800, 802, 820	FG9770 882, 892
HL5018 639	AG7620 736	EE5200 794, 798, 800	GK470 828, 830, 860, 862, 868
HL5033 635	AG7620 736	FB5610 782, 784, 786, 792, 808, 812, 818	HL5017 873, 895
JD5830 635	AG7620 736	FG7880 792, 798	HL5031 840, 841, 881, 889, 897
JD5865 635, 653	AG7620 736	GV311 780, 784, 790, 792, 796, 800, 802, 820	HM5290 873
JD5866 635, 651, 653	AG7620 736	HL5011 799	HM5292 883, 893
JD5914 643	AG7620 736	HL5017 795, 807, 809	HM5294 847, 877, 883, 893
JM5311 635	AG7620 736	HL5026 783, 795, 799, 801, 811	HR794 859, 875, 877, 879, 881
JM5314 637, 655	AG7620 736	HM5268 781, 785, 791, 793, 797, 801, 803, 821	HR5094 883, 892, 893
MERCEDES-BENZ	AG7620 736	HM5290 787, 795, 811, 823	HR5095 841, 881, 889, 897
AH5000 666, 668	AG7620 736	JD5841 793, 799, 801	HR5096 829, 849, 851
AH5010 674, 678, 680, 690, 696, 698, 700, 702	AG7620 736	MITSUBISHI	JD450 841, 843, 845, 859, 875, 883, 889, 891
AH5020 674, 678, 680, 690, 696, 698, 700, 702	AG7620 736	AG5302 740, 748, 758, 760, 768, 770	JD5867 861

 	 	 	 
OPEL	PEUGEOT	PEUGEOT	RENAULT
JD5868 845, 881, 883, 891, 893, 897	CG9030 934, 936, 946, 974	JD5907 961, 963, 971, 975	EG9760 1042, 1058, 1084, 1088
JD5869 881, 893	CG9310 928	JE5069 961, 963, 971, 975	EG9770 1034, 1092
JD5870 881, 893, 897	CG9720 960, 968	JE5070 961, 963, 971, 975	HA5030 1093
JD5891 873	CG9740 960, 968	JE5071 961, 963, 971, 975	HA5031 1093
JD5892 873	CG9750 960, 962, 970, 974	JE5072 927, 931, 935, 937, 939, 941, 947, 975, 977, 987	HL5013 1029, 1031, 1033, 1037, 1039, 1041, 1045, 1047, 1057, 1059, 1065, 1067, 1069, 1073, 1075, 1081, 1087, 1089
JD5896 883, 893	CH5040 960, 962, 970, 974	JH5107 937, 939, 947, 975, 987	HL5014 1033, 1035, 1041, 1051, 1071, 1075, 1077, 1079, 1081, 1083, 1091
JD5897 883, 893	CH5060 960, 962, 970, 974	JM5141 949, 959, 961, 971, 973, 975, 983	HL5015 1025, 1027, 1029, 1037, 1039, 1043, 1055, 1057, 1071, 1081
JD5903 843, 883, 897	ED5490 960, 970, 974	JM7035 937, 939, 947, 975, 987	HL5017 1031, 1033, 1043, 1045, 1047, 1051, 1057, 1059, 1085, 1089
JD5904 829, 833, 849, 851, 853, 855, 869, 883	ED5500 948, 962, 970, 974, 982	JM7042 929	HL5021 1025, 1043, 1091
JD5914 841, 849, 857, 863, 887	EG9030 934, 936, 946, 974	JM7042 929	HL5023 1035, 1049, 1083
JE5029 841, 849, 857, 887	EG9310 928	JM7051 935, 937, 947, 975	HL5026 1027, 1029, 1041, 1043, 1055, 1061, 1083, 1085, 1087
JE5064 841, 883, 893	EG9710 960, 968	JM7051 935, 937, 947, 975	HL5029 1027, 1029, 1041, 1045, 1053, 1055, 1057, 1061, 1083, 1085, 1087
JH5119 875	EG9750 960, 962, 970, 974	JM7052 935, 937, 947, 975	HL5032 1053, 1091
JJ508 877, 881	HA5029 929, 935, 939, 947, 975	RENAULT	HL5035 1025, 1035, 1049, 1051, 1093
JM5071 829, 833, 849, 851, 853, 855, 869, 883, 895	HA5030 937, 939, 947, 961, 977	AE5110 1024, 1032, 1042, 1048, 1058, 1086, 1092	HL5036 1026, 1027, 1043, 1059, 1091
JM7055 841, 881, 889, 897	HA5031 937, 939, 947, 961, 977	AG5420 1048, 1058	HL5039 1031, 1033, 1043, 1045, 1049, 1059, 1087, 1091, 1093
KG5337 845, 883, 891, 897	HA5032 937, 939, 947, 975, 987	AG9710 1034, 1048, 1082	HM5290 1025, 1035, 1049, 1051, 1093
NC004 841, 849	HL5010 933, 935, 941, 943, 945, 951, 953, 955, 957, 959, 961, 967, 969, 963, 969, 971, 973, 975, 979, 983, 989	AG9720 1034, 1048, 1082	HM5291 1043, 1059, 1085, 1089
PA543 859, 875, 877, 879, 881	HL5011 925, 927, 929, 931, 935, 937, 941, 947, 949, 953, 975, 985, 987	AG9730 1034, 1048, 1082	HM5292 1035, 1093
PA565 831, 833, 835, 837, 839, 843, 845, 847, 849, 851, 852, 853, 855, 857, 859, 861, 863, 865, 867, 869, 873, 875, 877, 881, 885, 887, 889, 891	HL5012 935, 937, 941, 943, 945, 955, 957, 959, 971, 977, 981, 987, 989	AG9740 1034, 1048, 1082	HR5094 1035, 1093
PEUGEOT	HL5014 965	AG9760 1042, 1058, 1084, 1088	JD5393 1027, 1029, 1041, 1045, 1053, 1055, 1057, 1061, 1083, 1085, 1087
AD5700 924, 926, 928, 930, 934, 940, 946, 948, 952, 974, 976, 986	HL5016 937, 945, 949, 959, 961, 963, 969, 971, 973, 975, 979, 983, 989	AG9770 1034, 1092	JD5394 1027, 1053, 1061, 1083, 1087
AG9030 934, 936, 946, 974	HL5019 933, 935, 939, 941, 943, 945, 947, 951, 953, 955, 957, 959, 961, 967, 969, 971, 973, 979, 981	AG9770 1034, 1092	JD5830 1093
AG9310 928	HL5022 985	AG9780 1034, 1092	JD5835 947
AG9710 960, 968	HL5027 969, 979	AG9790 1034, 1092	JD5845 929
AG9720 960, 968	HL5033 929, 935, 937, 939, 947, 961, 975	AG9800 1034, 1092	JD5846 929
AG9730 960, 968	HL5037 946, 947, 963, 972, 973	AG9810 1034, 1092	JD5863 929
AG9740 960, 968	HL5038 927, 937, 939, 947, 975, 987	AG9820 1034, 1092	JD5878 961, 969
AG9750 960, 962, 970, 974	HM5289 949, 963, 971, 975, 983	AH5040 1024, 1030, 1050, 1088	JD5879 961, 969
AH5040 960, 962, 970, 974	JD5830 937, 939, 947, 961, 977	AH5050 1024, 1030, 1050, 1088	JD5880 961, 969
AH5050 960, 962, 970, 974	JD5835 947	AH5060 1024, 1030, 1050, 1088	JD5881 949, 963, 971, 975, 983
AH5060 960, 962, 970, 974	JD5845 929	DL911 1028, 1064, 1066, 1068, 1072, 1088	JD5882 935, 937, 947, 975
AH5070 960, 962, 970, 974	JD5846 929	DS580 1026, 1070	JD5883 961, 963, 971, 975
AH5080 978	JD5863 929	EC5061 1042, 1046, 1056, 1084	JD5906 961, 963, 971, 975
AH5090 978	JD5878 961, 969	EE5110 1024, 1032, 1042, 1048, 1058, 1086, 1092	
AH5100 978	JD5879 961, 969	EE5200 1026, 1028, 1040, 1042, 1044, 1050, 1054, 1060, 1082, 1084, 1086, 1092	
AH5110 978	JD5880 961, 969	EG9710 1034, 1048, 1082	
BR510 932, 934, 938, 940, 950, 952, 954, 956, 970, 980	JD5881 949, 963, 971, 975, 983		
CC5011 948, 958, 968, 972, 982	JD5882 935, 937, 947, 975		
CD5130 928, 934, 938, 946, 974	JD5883 961, 963, 971, 975		
CD5140 936, 938, 946, 960, 976			
CD5490 960, 970, 974			
CD5500 948, 962, 970, 974, 982			

NEW PARTS LIST









Liste der Neuaufnahmen • Liste des nouvelles références
Lista de nuevas referencias

 RENAULT	 SAAB	 SKODA	 SUZUKI
JD5890 1043, 1047, 1057, 1085	CG9770 1134	CF5990 1186, 1194	CH5031 1230
JD5891 1025, 1035, 1049, 1051, 1093	EG9770 1134	CG8840 1186	EG5220 1220, 1222, 1224, 1228, 1230
JD5892 1025, 1035, 1049, 1051, 1093	FG9770 1134	CG8850 1190	EG5260 1220, 1222, 1228, 1232
JD5893 1027, 1053, 1061, 1083, 1087	HL5031 1131, 1133	DT581 1186, 1188	FG8100 1224
JD5894 1029, 1041, 1055, 1057, 1061, 1085	HM5292 1135	EF5380 1186, 1192, 1194, 1196	HA5029 1225
JD5895 1043, 1059, 1085, 1089	HR5094 1135	EF5990 1186, 1194	HL5010 1221, 1227, 1231
JD5896 1035, 1093	HR5095 1131, 1133	EG9600 1194	HL5016 1223
JD5897 1035, 1093	JD5896 1135	HL5020 1189, 1191	HL5016 1223
JD5906 1025, 1031, 1051, 1089	JD5897 1135	HL5034 1187, 1189, 1191, 1193, 1195, 1197	JM5071 1231
JD5907 1025, 1031, 1051, 1089	JE5064 1135	HL5040 1191, 1197	KJ502 1221, 1223, 1225
JD5908 1031, 1033, 1043, 1045, 1047, 1049, 1057, 1059, 1085, 1087, 1089	JE5065 1131, 1133	JD5817 1187, 1189	TALBOT
JD5910 1025, 1031, 1033, 1043, 1045, 1047, 1049, 1057, 1059, 1085, 1087, 1093	JE5066 1131, 1133	JD5818 1187, 1189	HL5010 1239
JD5911 1025, 1033, 1043, 1049, 1059, 1087, 1093	JM7055 1131, 1133	JD5849 1187, 1189	TOYOTA
JD5912 1049	SEAT	JD5851 1199	AG7600 1266, 1282, 1304, 1308, 1310
JE5060 1049	AG9600 1142, 1174, 1180	JD5873 1195	AG7610 1266, 1282, 1304, 1308, 1310
JE5061 1043, 1047, 1057, 1085	AG9630 1142, 1172, 1180	JE5075 1197	AG7620 1266, 1282, 1304, 1308, 1310
JE5062 1043, 1047, 1057, 1085	CF5990 1146, 1156	JE5076 1189, 1193	AG9310 1252, 1296, 1308, 1310
JE5063 1029, 1041, 1055, 1057, 1061, 1085	CG5010 1174, 1182	JF205 1191	AG9990 1248, 1264, 1278, 1294
JE5064 1035, 1093	CG5030 1142, 1174, 1182	JF211 1191	CD5381 1298, 1308, 1310
JE5069 1025, 1031, 1051, 1089	EF5380 1142, 1164, 1172, 1174, 1180	JH5117 1191	CF5030 1264, 1280, 1294, 1302
JE5070 1025, 1031, 1051, 1089	EF5990 1146, 1156	JM7031 1195	CF5781 1248, 1250, 1252, 1282, 1286, 1288, 1296, 1310
JE5071 1025, 1031, 1051, 1089	EG9600 1142, 1174, 1180	NA5278 1187, 1193, 1195	CF5980 1282, 1284, 1286, 1288
JH5108 1027, 1029, 1041, 1045, 1053, 1055, 1057, 1061, 1083, 1085, 1087	HL5020 1141, 1143, 1145, 1147, 1149, 1151, 1153, 1155, 1157, 1159, 1161, 1163, 1165, 1167, 1169, 1171, 1175, 1177, 1179, 1181, 1183	SMART	CG7480 1276
JH5109 1027, 1029, 1041, 1055, 1061, 1084, 1085, 1087	HL5034 1141, 1143, 1145, 1149, 1151, 1153, 1155, 1159, 1161, 1165, 1167, 1171, 1173, 1175, 1177, 1179, 1181	CC5670 1200	CG7490 1276, 1298, 1300, 1306
JM7053 1027, 1059, 1091	HL5040 1141, 1173, 1177	EC5670 1200	CG7491 1274, 1276
JM7054 1027, 1029, 1041, 1043, 1045, 1051, 1055, 1061, 1083, 1085, 1087, 1093	JD5288 1175	HA5034 1201	CG7520 1290
KK5643 1027, 1029, 1041, 1043, 1055, 1061, 1083, 1085, 1087	JD5873 1143, 1175, 1181	SSANGYONG	CG7600 1266, 1282, 1304, 1308, 1310
	JE5076 1145, 1147, 1153, 1157, 1163, 1165, 1171	JD169 1205, 1207	CG8300 1304
	JF205 1141, 1143, 1151, 1157, 1163, 1167, 1173, 1177, 1183	KJ779 1205, 1207	CG9310 1252, 1296, 1308, 1310
	JH5117 1141, 1151, 1161, 1171, 1173, 1177	KK5683 1205, 1207	EG9310 1252, 1296, 1308, 1310
	JM7031 1143, 1175, 1181	SUBARU	FF5030 1264, 1280, 1294, 1302
	JM7045 1143, 1175, 1183	CF5760 1216	FF5781 1248, 1250, 1252, 1282, 1286, 1288, 1296, 1310
	NA5278 1141, 1147, 1153, 1155, 1165, 1167, 1173, 1177, 1179, 1181	CG5582 1210, 1212	FF5980 1282, 1284, 1286, 1288
	NB633 1179, 1181	CG5600 1214, 1216	FG7480 1250, 1274, 1276, 1298, 1300, 1306
	SKODA	CG6150 1210, 1214, 1216	FG7600 1266, 1282, 1304, 1308, 1310
	AG9600 1194	CG67980 1216	FG7650 1250, 1252, 1254, 1274, 1276, 1280, 1292, 1294, 1300, 1304, 1306, 1308
	AG9630 1194, 1196	DV544 1212	HM5243 1265, 1281, 1295, 1303
	CC5960 1198	EG5220 1212	JA5058 1249, 1283, 1291
		FF5760 1216	JD5845 1253, 1297, 1309, 1311
		FG5600 1214, 1216	JD5846 1253, 1297, 1309, 1311
		FG7980 1216	JD5863 1253, 1297, 1309, 1311
		HM5254 1211, 1213	JD5901 1251, 1275, 1277, 1299, 1301, 1307
		HM5257 1217	JM7042 1253, 1297, 1309, 1311
		SUZUKI	
		AG8020 1220, 1222, 1228, 1230	
		AG8100 1224	
		AG8110 1224	
		CD5130 1224	
		CG5710 1230	
		CG5730 1222	
		CG8020 1220, 1222, 1228, 1230	
		CG8100 1224	
		CG8180 1222, 1224, 1226, 1232	

 VAUXHALL	 VAUXHALL	 VOLVO	 VW
AB5781 1358, 1360	JD5904 1321, 1323, 1351, 1353, 1355, 1357, 1359, 1373	HM5289 1403, 1411, 1421, 1429, 1431	HL5020 1455, 1457, 1459, 1461, 1463, 1465, 1467, 1469, 1471, 1473, 1475, 1477, 1479, 1483, 1485, 1487, 1489, 1491, 1495, 1497, 1501, 1503, 1505, 1507, 1509, 1511, 1513, 1517, 1519, 1521, 1523, 1525, 1527, 1529, 1531, 1533, 1535, 1537, 1541, 1543, 1547, 1549, 1551
AG9570 1332, 1334, 1378, 1380	JD5914 1325, 1355	HM5293 1395, 1399, 1401	HL5034 1449, 1453, 1457, 1459, 1461, 1467, 1469, 1481, 1483, 1485, 1489, 1491, 1493, 1497, 1499, 1501, 1503, 1511, 1513, 1515, 1523, 1525, 1531, 1535, 1537, 1539, 1541, 1543
AG9580 1334, 1376, 1378, 1380	JD5915 1337	JA5043 1397, 1399, 1431	HL5040 1475, 1477, 1499, 1509, 1513, 1529, 1535
AG9590 1370, 1376, 1380	JE5029 1325, 1331, 1339, 1349, 1353, 1357, 1365, 1367, 1375	JD5288 1405, 1407, 1413, 1415, 1419, 1421, 1423, 1433, 1435, 1437, 1439, 1441	JD5817 1495
AG9770 1370, 1376	JE5064 1371, 1377	JD5865 1403, 1407, 1429	JD5818 1495
AG9780 1370, 1376	JH5119 1367	JD5866 1403, 1407, 1429	JD5849 1495
AG9790 1370, 1376	JJ508 1345, 1369	JD5881 1403, 1411, 1421, 1429, 1431	JD5851 1515
AG9800 1370, 1376	JM5071 1321, 1323, 1353, 1355, 1359, 1373	JD5898 1425	JD5872 1517, 1539
AG9810 1370, 1376	JM7055 1333, 1371, 1375, 1379	JM5290 1409, 1427	JD5873 1463, 1485, 1491, 1513, 1515, 1539
AG9820 1370, 1376	KG5337 1335, 1377, 1379, 1381	JM5291 1409, 1427	JD5874 1463, 1487, 1499, 1517, 1539, 1547
AH5030 1320, 1322, 1350, 1352, 1354, 1356, 1358, 1372	NA5271 1329, 1339, 1347	NA5273 1407, 1413, 1415, 1421, 1431, 1433, 1437	JE138 1493, 1495
BJ170 1342, 1344, 1358, 1368	NC004 1349	VW	JE5075 1541
CE5950 1320, 1352	PA543 1345, 1359	AG9600 1462, 1484, 1490, 1512, 1514, 1538	JE5076 1451, 1459, 1473, 1475, 1477, 1479, 1483, 1495, 1507, 1509, 1517, 1525, 1529, 1531, 1549, 1551
CG5781 1360	PA565 1323, 1325, 1327, 1329, 1331, 1333, 1335, 1337, 1339, 1341, 1343, 1345, 1347, 1349, 1351, 1353, 1354, 1355, 1357, 1363, 1365, 1367, 1369, 1373	AG9610 1462, 1486, 1498, 1516, 1538, 1546	JF205 1449, 1461, 1463, 1469, 1471, 1475, 1485, 1491, 1503, 1509, 1513, 1535, 1537, 1547, 1551
CG9570 1332, 1334, 1378, 1380	VOLVO	AG9630 1460, 1462, 1482, 1490, 1514, 1536, 1540	JF211 1449, 1467
CG9580 1334, 1376, 1378, 1380	AG9560 1402, 1406, 1428	CC5223 1500	JH5117 1449, 1453, 1467, 1475, 1477, 1483, 1499, 1501, 1503, 1525, 1535
CG9590 1370, 1376, 1380	CA5640 1424	CC5960 1514	JM7030 1513
CG9770 1370, 1376	CA5641 1424	CF5990 1518	JM7031 1483, 1493, 1515, 1541
CH5030 1320, 1322, 1350, 1352, 1354, 1356, 1358, 1372	CB5451 1406, 1412, 1418, 1420, 1422, 1430, 1434	CG5000 1544	JM7045 1455, 1463, 1485, 1487, 1499, 1517, 1539, 1545, 1547
CH5031 1320, 1352	CD5500 1402, 1410, 1420, 1428, 1430	CG5010 1454, 1484	JM7046 1517, 1539
DN042 1320	CE5150 1424, 1440	CG5020 1454, 1484	JM7047 1517, 1539
DY260 1340, 1350	CE5160 1424	CG5030 1454, 1484, 1538	JM7048 1485, 1539
EC102 1356	CE5170 1424	CG8840 1462, 1518	JN438 1513, 1515, 1533
EG9570 1332, 1334, 1378, 1380	CE5171 1424	CG8850 1462, 1466, 1488, 1504, 1522, 1538	JN849 1493
EG9770 1370, 1376	DL911 1386, 1388, 1390	CG9600 1484, 1538	
ES260 1322, 1324, 1326, 1336, 1346, 1350, 1352, 1354, 1355, 1362, 1364	EB5120 1402, 1406, 1428	CG9610 1462, 1486, 1498, 1516, 1538, 1546	
FG9770 1370, 1376	ED5500 1402, 1410, 1420, 1428, 1430	CG9620 1452, 1484, 1500	
HL5017 1361, 1377	EE5150 1424, 1440	CG9621 1514	
HL5031 1333, 1371, 1375, 1379	EE5250 1402, 1404, 1406, 1412, 1414, 1416, 1418, 1420, 1422, 1430, 1432, 1434, 1436, 1438, 1440	EF5380 1458, 1460, 1462, 1482, 1484, 1490, 1492, 1496, 1510, 1514, 1536, 1538, 1540, 1542	
HM5278 1371	HA5040 1397, 1415, 1431	EG5990 1462, 1518	
HM5290 1361	HA5041 1397, 1399, 1403, 1405, 1407, 1413, 1415, 1417, 1419, 1421, 1423, 1431, 1433, 1435, 1437, 1439, 1441	EG5000 1544	
HM5292 1371, 1377	HA5042 1401, 1403, 1425, 1439, 1441	EG5010 1484, 1500, 1514, 1516, 1538	
HM5294 1343, 1351, 1369, 1371	HL5013 1391, 1393, 1411, 1429	EG9600 1462, 1484, 1490, 1512, 1514, 1538	
HR794 1345, 1359	HL5017 1409, 1427		
HR5094 1371, 1377			
HR5095 1333, 1371, 1375, 1379			
HR5096 1321, 1353			
JD450 1331, 1333, 1341, 1351, 1359, 1367, 1371, 1375, 1377			
JD5868 1335, 1371, 1377, 1379, 1381			
JD5869 1371, 1377, 1381			
JD5870 1371, 1377, 1381			
JD5891 1361			
JD5892 1361			
JD5896 1371, 1377			
JD5897 1371, 1377			
JD5903 1333, 1335, 1379, 1381			

NEW PARTS LIST

Liste der Neuaufnahmen • Liste des nouvelles références
Lista de nuevas referencias

							
VW							
NA5278	1451, 1453, 1459, 1469, 1470, 1471, 1475, 1477, 1479, 1481, 1485, 1491, 1493, 1495, 1497, 1501, 1503, 1505, 1507, 1509, 1511, 1513, 1527, 1529, 1531, 1533, 1537, 1541, 1543, 1545, 1547, 1551						
NB953	1541, 1543						
ZASTAVA							
BP090	1554						

ACURA



















KW/PS



Integra 1.6L				01/85 → 12/90	1	BV350 (Graphite) (30-028143-00)	DV351 (21-28143-21/0)	
Integra 1.6L i				01/85 → 12/90				
Integra Coupe 1.6L				01/85 → 12/90				
Integra Coupe 1.6L i				01/85 → 12/90				
	1590	4			74/100			
	1590	4			88/120			
Legend 2.5L				01/86 → 12/87	2	BP640 (Graphite) (x2)		
	2494	6			122/165			
Legend 3.2L				08/91 → 08/96	3	BV090 (Graphite) <input checked="" type="checkbox"/> BV100 (Graphite) <input checked="" type="checkbox"/>	DV090	
C32A	3206	6	90.00 DOHC, V6		151/205			
Legend Coupe 3.2L				08/91 → 08/96	4	BV090 (Graphite) <input checked="" type="checkbox"/> BV100 (Graphite) <input checked="" type="checkbox"/>	DV090	
C32A2	3206	6	90.00 DOHC, V6		151/205			
NSX Coupe 3.0L				01/90 → 08/97	5		CG7860 01/91 → 12/96	
C30A3	2977	6	90.00 Injection, DOHC, V6					
NSX Coupe R 3.0L				01/92 → 08/97	6		CG7860	
NSX T 3.0L				01/95 →				
C30A4	2977	6	90.00 Injection, DOHC					
NSX Coupe 3.2L				08/97 →	7		CG7870 C32B2	
C32B2	3179	6	93.00 Injection, V6					

	JD075 JD052 JE625 JF024 (x2)	JN744					 BP640 JN633 JN744 JJ364
	JC687 (x2) JE625	JN633 (x2)	JJ364	PA528 (x12)	NJ933 (x2) 35x50x8mm, FPM NK023 41x56x8mm, ACM NJ675 80x98x10mm, NBR		 BV090 BV100 BV350 JC687
		HM5248 (x2) →12/95 C32A1		PB355 PB356	NK023 41x56x8mm, ACM		 JD052 JD075
		HM5248 (x2) →12/95		PB355 PB356	NK023 41x56x8mm, ACM		

		CC			9			CC			9
160 D100	Diesel	1929	4	82.60	124	AR 01646	Petrol	2492	6	88.00	29
182 B9.000	Diesel	1910	4	82.00	50	AR 01648	Petrol	2492	6	88.00	23
192 A5.000	Diesel	1910	4	82.00	51	AR 01655	Petrol	1962	4	84.00	121
192 A5.000	Diesel	1910	4	82.00	75	AR 01655	Petrol	1962	4	84.00	137
192 B1.000	Diesel	1910	4	82.00	53	AR 01655	Petrol	1962	4	84.00	146
192 B1.000	Diesel	1910	4	82.00	74	AR 01678	Petrol	1779	4	80.00	120
199 A8.000	Petrol	1368	4	72.00	152	AR 01678	Petrol	1779	4	80.00	135
8140.21.200 D.I.	Diesel	2445	4	93.00	129	AR 01713	Petrol	1962	4	84.00	121
8140.61.200	Diesel	2445	4	93.00	128	AR 01713	Petrol	1962	4	84.00	26
8140.61.200	Diesel	2445	4	93.00	130	AR 01911	Petrol	2492	6	88.00	23
8144.21.220	Diesel	2445	4	93.00	126	AR 01911	Petrol	2492	6	88.00	29
8144.61.200	Diesel	2445	4	93.00	125	AR 06100	Petrol	1567	4	78.00	14
8144.67.220	Diesel	2500	4	93.00	127	AR 06120	Petrol	2959	6	93.00	24
8144.67.220	Diesel	2500	4	93.00	131	AR 06124	Petrol	2959	6	93.00	24
839 A6.000	Diesel	2387	5	82.00	106	AR 06134	Petrol	1779	4	80.00	18
839 A6.000	Diesel	2387	5	82.00	80	AR 06158	Petrol	1779	4	80.00	18
841 C.000	Diesel	2387	5	82.00	107	AR 06166	Petrol	1962	4	84.00	20
841 C.000	Diesel	2387	5	82.00	80	AR 06168	Petrol	1779	4	80.00	16
841 G.000	Diesel	2387	5	82.00	108	AR 06202	Petrol	1779	4	80.00	15
841 G.000	Diesel	2387	5	82.00	81	AR 06202	Petrol	1779	4	80.00	25
841 H.000	Diesel	2387	5	82.00	108	AR 06210	Petrol	1997	6	80.00	27
932 A.000	Petrol	3179	6	93.00	55	AR 06212	Petrol	1962	4	84.00	146
932 A.000	Petrol	3179	6	93.00	84	AR 06212	Petrol	1962	4	84.00	19
932 A2.000	Petrol	1970	4	83.00	143	AR 06212	Petrol	1962	4	84.00	26
936 A.000	Petrol	3179	6	93.00	112	AR 06224	Petrol	1962	4	84.00	20
936 A.000	Petrol	3179	6	93.00	144	AR 06410	Petrol	2959	6	93.00	100
936 A6.000	Petrol	3179	6	93.00	167	AR 06412	Petrol	2959	6	93.00	100
937 A1.000	Petrol	1970	4	83.00	143	AR 06416	Petrol	1962	4	84.00	94
937 A1.000	Petrol	1970	4	83.00	147	AR 06420	Petrol	1962	4	84.00	94
937 A1.000	Petrol	1970	4	83.00	158	AR 06430	Petrol	2959	6	93.00	100
937 A1.000	Petrol	1970	4	83.00	78	AR 06476	Petrol	1995	4	84.00	96
937 A2.000	Diesel	1910	4	82.00	49	AR 10520	Petrol	1962	4	84.00	113
937 A2.000	Diesel	1910	4	82.00	73	AR 10520	Petrol	1962	4	84.00	121
937 A4.000	Diesel	1910	4	82.00	53	AR 11671	Petrol	1962	4	84.00	137
937 A4.000	Diesel	1910	4	82.00	74	AR 16101	Petrol	2959	6	93.00	166
937 A5.000	Diesel	1910	4	82.00	142	AR 16102	Petrol	2959	6	93.00	151
937 A5.000	Diesel	1910	4	82.00	52	AR 16102	Petrol	2959	6	93.00	165
937 A5.000	Diesel	1910	4	82.00	74	AR 16105	Petrol	2959	6	93.00	151
937 A5.000	Diesel	1910	4	82.00	75	AR 16105	Petrol	2959	6	93.00	165
937 A8.000	Diesel	1910	4	82.00	89	AR 16201	Petrol	1970	4	83.00	148
937 A8.000	Diesel	1910	4	82.00	90	AR 16201	Petrol	1970	4	83.00	159
937A7.000	Diesel	1910	4	82.00	86	AR 16202	Petrol	1997	6	80.00	150
939 A1.000	Diesel	1910	4	82.00	91	AR 16202	Petrol	1997	6	80.00	161
939 A2.000	Diesel	1910	4	82.00	87	AR 30102	Petrol	1186	4	80.00	114
939 A2.000	Diesel	1910	4	82.00	88	AR 30124	Petrol	1490	4	84.00	118
939 A3.000	Diesel	2387	5	82.00	93	AR 30128	Petrol	1490	4	84.00	118
939 A5.000	Petrol	2198	4	86.00	134	AR 30143	Petrol	1490	4	84.00	8
939 A5.000	Petrol	2198	4	86.00	164	AR 30146	Petrol	1490	4	84.00	118
939 A5.000	Petrol	2198	4	86.00	92	AR 30146	Petrol	1490	4	84.00	7
939 A6.000	Petrol	1859	4	86.00	85	AR 30146	Petrol	1490	4	84.00	8
939 A6.000	Petrol	1859	4	86.00	86	AR 30160	Petrol	1287	4	80.00	115
939 A7.000	Diesel	1910	4	82.00	86	AR 30164	Petrol	1351	4	80.00	115
939 A8.000	Diesel	1910	4	82.00	89	AR 30164	Petrol	1351	4	80.00	117
AR 00526	Petrol	1567	4	78.00	154	AR 30168	Petrol	1351	4	80.00	115
AR 00526	Petrol	1567	4	78.00	155	AR 30168	Petrol	1351	4	80.00	117
AR 00530	Petrol	1290	4	74.00	139	AR 30168	Petrol	1351	4	80.00	132
AR 00530	Petrol	1290	4	74.00	153	AR 30168	Petrol	1351	4	80.00	3
AR 00536	Petrol	1567	4	78.00	140	AR 30182	Petrol	1490	4	84.00	133
AR 00536	Petrol	1567	4	78.00	154	AR 30182	Petrol	1490	4	84.00	7
AR 01354	Petrol	1779	4	80.00	136	AR 30184	Petrol	1490	4	84.00	116
AR 01544	Petrol	1962	4	84.00	162	AR 30502	Petrol	1351	4	80.00	3
AR 01563	Petrol	1570	4	78.10	156	AR 30504	Petrol	1490	4	84.00	6
AR 01588	Petrol	1962	4	84.00	163	AR 30504	Petrol	1490	4	84.00	8
AR 01600	Petrol	1567	4	78.00	119	AR 30508	Petrol	1490	4	84.00	7
AR 01600	Petrol	1567	4	78.00	154	AR 30508	Petrol	1490	4	84.00	8
AR 01608	Petrol	1779	4	80.00	120	AR 30520	Petrol	1490	4	84.00	6
AR 01608 X	Petrol	1779	4	80.00	120	AR 30520	Petrol	1490	4	84.00	7
AR 01623	Petrol	1962	4	84.00	121	AR 30558	Petrol	1717	4	87.00	12
AR 01646	Petrol	2492	6	88.00	23	AR 30585	Petrol	1186	4	80.00	2

		CC			9			CC			9
AR 30586	Petrol	1351	4	80.00	3	AR 38401	Petrol	1747	4	82.00	35
AR 30587	Petrol	1351	4	80.00	3	AR 38401	Petrol	1747	4	82.00	43
AR 30587	Petrol	1351	4	80.00	5	AR 38501	Petrol	1371	4	82.00	31
AR 30588	Petrol	1490	4	84.00	6	AR 38501	Petrol	1371	4	82.00	40
AR 30588	Petrol	1490	4	84.00	7	AR 61101	Petrol	1567	4	78.00	14
AR 30588	Petrol	1490	4	84.00	8	AR 61102	Petrol	1779	4	80.00	16
AR 30734	Petrol	1490	4	84.00	6	AR 61201	Petrol	1779	4	80.00	17
AR 30736	Petrol	1717	4	87.00	11	AR 61503	Petrol	2959	6	93.00	24
AR 30736	Petrol	1717	4	87.00	12	AR 64101	Petrol	1997	6	80.00	97
AR 30737	Petrol	1717	4	87.00	11	AR 64102	Petrol	1997	6	80.00	97
AR 30737	Petrol	1717	4	87.00	12	AR 64103	Petrol	1995	4	84.00	95
AR 30737 A	Petrol	1717	4	87.00	11	AR 64301	Petrol	2959	6	93.00	100
AR 30746	Petrol	1717	4	87.00	10	AR 64305	Petrol	2959	6	93.00	101
AR 30747	Petrol	1717	4	87.00	10	AR 66303	Petrol	2959	6	93.00	101
AR 30750	Petrol	1490	4	84.00	9	AR 67101	Petrol	1773	4	84.00	59
AR 30751	Petrol	1490	4	84.00	9	AR 67102	Petrol	1773	4	84.00	59
AR 30753	Petrol	1351	4	80.00	4	AR 67103	Petrol	1748	4	83.40	57
AR 30755	Petrol	1351	4	80.00	4	AR 67105	Petrol	1748	4	83.40	57
AR 30755	Petrol	1351	4	80.00	5	AR 67106	Petrol	1747	4	82.00	35
AR 31010	Petrol	1351	4	80.00	132	AR 67106	Petrol	1747	4	82.00	43
AR 32102	Petrol	1598	4	82.00	67	AR 67106	Petrol	1747	4	82.00	58
AR 32102	Petrol	1598	4	82.00	68	AR 67201	Petrol	1995	4	84.00	63
AR 32103	Petrol	1598	4	82.00	67	AR 67202	Petrol	1970	4	83.00	62
AR 32103	Petrol	1598	4	82.00	68	AR 67203	Petrol	1995	4	84.00	61
AR 32104	Petrol	1598	4	82.00	48	AR 67204	Petrol	1970	4	83.00	39
AR 32104	Petrol	1598	4	82.00	67	AR 67204	Petrol	1970	4	83.00	47
AR 32104	Petrol	1598	4	82.00	68	AR 67204	Petrol	1970	4	83.00	64
AR 32201	Petrol	1747	4	82.00	145	AR 67301	Petrol	2492	6	88.00	66
AR 32201	Petrol	1747	4	82.00	157	AR 67302	Petrol	2492	6	88.00	66
AR 32201	Petrol	1747	4	82.00	35	AR 67303	Petrol	2492	6	88.00	66
AR 32201	Petrol	1747	4	82.00	43	AR 67402	Petrol	1748	4	83.40	59
AR 32201	Petrol	1747	4	82.00	69	AR 67501	Diesel	1929	4	82.60	37
AR 32205	Petrol	1747	4	82.00	141	AR 67501	Diesel	1929	4	82.60	45
AR 32205	Petrol	1747	4	82.00	70	AR 67501	Diesel	1929	4	82.60	60
AR 32301	Petrol	1970	4	83.00	149	AR 67601	Petrol	1598	4	82.00	33
AR 32301	Petrol	1970	4	83.00	160	AR 67601	Petrol	1598	4	82.00	41
AR 32301	Petrol	1970	4	83.00	38	AR 67601	Petrol	1598	4	82.00	56
AR 32301	Petrol	1970	4	83.00	46	AR 67601	Petrol	1598	4	82.00	67
AR 32301	Petrol	1970	4	83.00	76	AR 67601	Petrol	1598	4	82.00	68
AR 32302	Diesel	1910	4	82.00	36	VM 07 B	Diesel	2500	4	92.00	65
AR 32302	Diesel	1910	4	82.00	44	VM 08 B	Diesel	2500	4	92.00	98
AR 32302	Diesel	1910	4	82.00	71	VM 31 B	Diesel	2500	4	92.00	65
AR 32310	Petrol	1970	4	83.00	148	VM 32 B	Diesel	2499	4	92.00	98
AR 32310	Petrol	1970	4	83.00	159	VM 4 HT	Diesel	1995	4	88.00	138
AR 32310	Petrol	1970	4	83.00	54	VM 4HT 2.4	Diesel	2393	4	92.00	123
AR 32310	Petrol	1970	4	83.00	77	VM 4HT/2	Diesel	1995	4	88.00	122
AR 32401	Petrol	2492	6	88.00	82	VM 80 A	Diesel	1995	4	88.00	21
AR 32405	Petrol	2492	6	88.00	83	VM 81 A	Diesel	2393	4	92.00	22
AR 32501	Diesel	2387	5	82.00	79	VM 81 A	Diesel	2393	4	92.00	28
AR 33201	Petrol	1596	4	84.00	32	VM 82 A	Diesel	1779	3	92.00	13
AR 33401	Petrol	1717	4	87.00	34	VM 84 A	Diesel	2500	4	92.00	98
AR 33401	Petrol	1717	4	87.00	42	VM 96 A	Diesel	1779	3	92.00	13
AR 33501	Petrol	1351	4	80.00	30	VM HR 588 HT	Diesel	2494	5	88.00	1
AR 33503	Petrol	1371	4	82.00	31						
AR 33503	Petrol	1371	4	82.00	40						
AR 33601	Diesel	1929	4	82.60	37						
AR 33601	Diesel	1929	4	82.60	45						
AR 34102	Petrol	1997	6	80.00	104						
AR 34103	Petrol	1970	4	83.00	102						
AR 34201	Petrol	2492	6	88.00	109						
AR 34202	Diesel	2387	5	82.00	105						
AR 34301	Petrol	2959	6	93.00	111						
AR 36101	Petrol	2959	6	93.00	111						
AR 36201	Petrol	2492	6	88.00	110						
AR 36301	Petrol	1970	4	83.00	103						
AR 37101	Diesel	1910	4	82.00	72						
AR 37203	Petrol	1598	4	82.00	48						
AR 38201	Petrol	1598	4	82.00	33						
AR 38201	Petrol	1598	4	82.00	41						











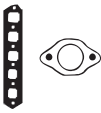

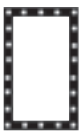

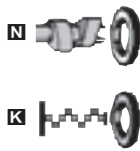

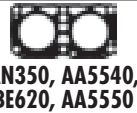

























ALFA ROMEO



KW/PS



6 2.5L TD Diesel					07/81 → 05/86	1	BK570 (Fibre), 1.42mm, 0 Notches (x5) (30-025008-20) BP260 (Fibre), 1.52mm, 2 Notches (x5) (30-025013-20) BK580 (Fibre), 1.62mm, 1 Notch (x5) (30-025007-20)	DK572▲○ [89]	GK571▲○ [12] [36] [89]
VM HR 588 HT	2494	5	88.00	OHV		79/107			
33 1.2L					06/83 → 12/89	2	AN350 (Fibre) (x2) (30-026481-00)	CN353 (21-26481-20/0)	FN353 (20-26481-00/0)
AR 30585	1186	4	80.00			50/68			
33 1.3L					06/83 → 12/89	3	AA5540 (Fibre) (x2) (30-030087-00) AN350 (Fibre) (x2) (30-026481-00)	CN353 (21-26481-20/0)	FN353 (20-26481-00/0)
AR 30502	1351	4	80.00	Carburettor		55/75			
AR 30168	1351	4	80.00	Carburettor		63/85			
AR 30586/AR 30587	1351	4	80.00			63/86			
33 1.4L i.e.					06/91 → 09/94	4	AA5540 (Fibre) (x2) (30-030087-00) AN350 (Fibre) (x2) (30-026481-00)	CN355 (21-26481-21/0)	FN355 (20-26481-01/0)
AR 30753/AR 30755	1351	4	80.00			66/89			
33 1.4L i.e.					06/91 → 09/94	5	AA5540 (Fibre) (x2) (30-030087-00) AN350 (Fibre) (x2) (30-026481-00)	CN353 (21-26481-20/0)	FN353 (20-26481-00/0) FN355 (20-26481-01/0)
AR 30587	1351	4	80.00			63/86			
AR 30755	1351	4	80.00			66/89			
33 1.5L					12/86 → 04/93	6	BE620 (Fibre) (30-024362-10)		
33 1.5L 4x4					11/83 → 12/89				
AR 30504	1490	4	84.00	SOHC		62/84			
AR 30520	1490	4	84.00	SOHC		77/105			
AR 30588/AR 30734	1490	4	84.00	Boxer		77/105			
33 1.5L					05/83 → 12/93	7	BE620 (Fibre) (x2) (30-024362-10)	DE622 (21-24362-21/0)	GE621 GE622
33 1.5L 4x4					09/84 → 12/89				
33 1.5L QV					06/84 → 12/89				
AR 30146/ AR 30182/ AR 30508/AR 30520	1490	4	84.00	SOHC		77/105			
AR 30588	1490	4	84.00	Boxer		77/105			
33 1.5L					06/83 → 12/85	8	BE620 (Fibre) (x2) (30-024362-10)	DE622 (21-24362-21/0)	GE621 GE622
33 1.5L 4x4					12/86 → 03/89				
AR 30504	1490	4	84.00	SOHC		62/84			
AR 30143	1490	4	84.00	SOHC		70/77/ 95			
AR 30146/AR 30508	1490	4	84.00	SOHC		77/105			
AR 30588	1490	4	84.00	Boxer		77/105			
33 1.5L i.e.					01/90 → 09/94	9	BE620 (Fibre) (x2) (30-024362-10)	DE623 (21-24362-22/0)	GE623 (20-24362-02/0)
33 1.5L i.e.					07/90 → 08/91				
AR 30751	1490	4	84.00			72/74/ 98/101			
AR 30750	1490	4	84.00			74/100			
33 1.7L 16V					01/90 → 09/94	10	AA5550 (Fibre) (x2) [249] BT340 (Graphite) (x2) (30-027162-00)	DT340 (21-27162-20/0)	GT340 (20-27162-00/0)
33 1.7L 16V 4x4					01/90 → 09/94				
AR 30746/AR 30747	1717	4	87.00	i.e., DOHC		95/98/ 130/ 133			
33 1.7L i.e.					01/90 → 09/94	11			
AR 30736/AR 30737	1717	4	87.00	SOHC		77/105			
AR 30737 A	1717	4	87.00			77/105			

								
HBS106 (22-56002B) M14x2.0x137mm (x12) M12x1.75x80mm (x5) M12x1.75x116mm (x5)	JC928 (x5) (31-025852-10) JD5144 (31-028425-00) JD025 (x5) (31-025849-10)	JN581 (x5)						 AN350, AA5540, BE620, AA5550
	JC507 (x2) JA899 (x4) (31-026340-10)  JE696 (32-202195-10)	JM669 (x2) (31-023086-00) JN588 (31-025164-10)	JH565	HR602 24-30670-61/0	 NA5064 35x58x10mm, ACM (50-306562-50)  NA5063 40x56x10mm, ACM  NA5065 62x80x12mm, ACM	JR349 [11] KV123 [11] KV124 [11]	 JN811	
	JC507 (x2) JA899 (x4) (31-026340-10)	JM669 (x2) (31-023086-00) JN588 (x2) (31-025164-10)	JH565	HR602 24-30670-61/0	 NA5064 35x58x10mm, ACM (50-306562-50)  NA5063 40x56x10mm, ACM  NA5065 62x80x12mm, ACM	HJ287 [39]  JR349 [11] KV123 [11] KV124 [11]	 JH565	
	JD221 (x2) (31-026835-10) JA899 (x4) (31-026340-10)	JN588 (x2) (31-025164-10)	JJ450	HR363	 NA5064 35x58x10mm, ACM (50-306562-50)	JR349 [11] KV123 [11] KV124 [11]	 JJ450	
	JC507 (x2) JA899 (x4) (31-026340-10)  JE744	JM669 (x2) (31-023086-00) JN588 (x2) (31-025164-10)	JH565	HR602 24-30670-61/0	 NA5064 35x58x10mm, ACM (50-306562-50)  NA5063 40x56x10mm, ACM  NA5065 62x80x12mm, ACM	HJ287 [39]  JR349 [11] KV123 [11] KV124 [11]	 JC507	
	JC507 (x2) JA899 (x4) (31-026340-10)	JM669 (x2) (31-023086-00) JN588 (x2) (31-025164-10)	JH565		 NA5063 40x56x10mm, ACM  NA5064 35x58x10mm, ACM (50-306562-50)  NA5065 62x80x12mm, ACM	NJ419 [2] JR349 [11] KV123 [11] KV124 [11]	 JA899	
	JC507 (x2) JA899 (x4) (31-026340-10)	JM669 (x2) (31-023086-00) JN588 (x2) (31-025164-10)	JH565		 NA5063 40x56x10mm, ACM  NA5064 35x58x10mm, ACM (50-306562-50)  NA5065 62x80x12mm, ACM	NJ419 [2] HJ287 [39]  JR349 [11] KV123 [11] KV124 [11]	 JC507	
	JD221 (x2) (31-026835-10) JA899 (x4) (31-026340-10)	JN588 (x2) (31-025164-10)	JJ450	HR363		JR349 [11] KV123 [11] KV124 [11]	 JC928	
	JD014 (x4) (31-028772-00) JD565 (x4) (31-026319-00)	JN811 (x5) (50-028774-00) JN810 (x5) (50-028773-00)	JJ450	HR800	 NA5063 40x56x10mm, ACM  NA5065 62x80x12mm, ACM		 JD014	
				HR363	 NA5064 35x58x10mm, ACM (50-306562-50)  NA5063 40x56x10mm, ACM  NA5065 62x80x12mm, ACM		 JD025	

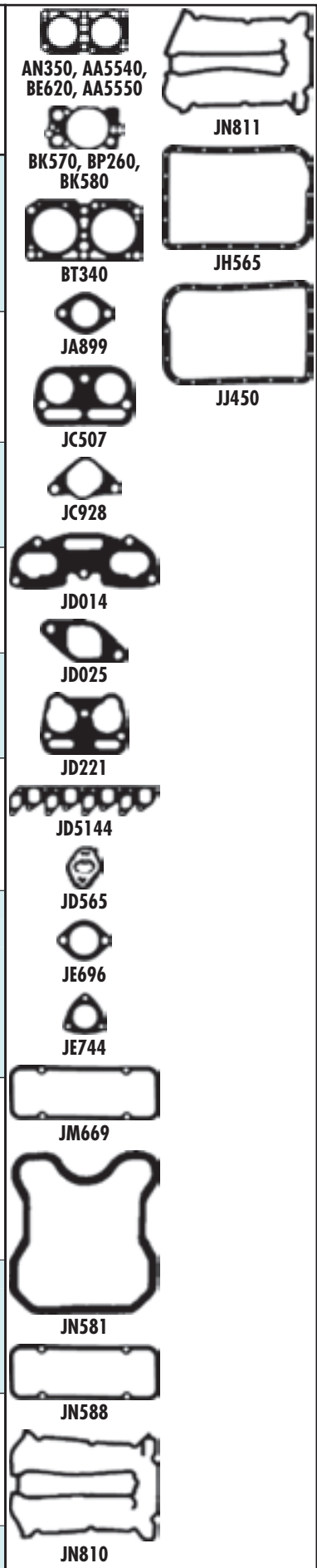











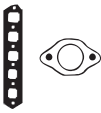

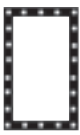

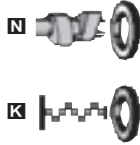





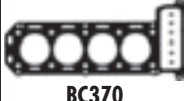
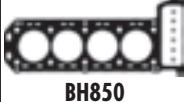













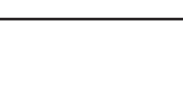







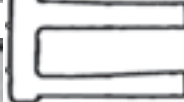
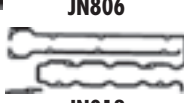
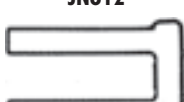



















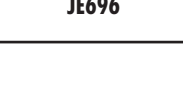















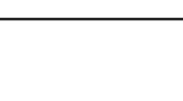











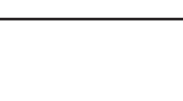





























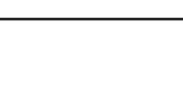

ALFA ROMEO



KW/PS

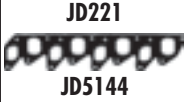

33 1.7L i.e. 09/88 → 09/94 12						BP990 (Fibre) (x2) (30-026017-20)	DP990 (21-26017-21/0)	GP990
33 1.7L i.e. 4x4 09/88 → 03/92								
AR 30736/AR 30737	1717	4	87.00	SOHC	77/105			
AR 30558	1717	4	87.00	Injection, SOHC	84/114			
33 1.8L TD Diesel 01/86 → 09/94 13						BK570 (Fibre), 1.42mm, 0 Notches (x3) (30-025008-20) BP260 (Fibre), 1.52mm, 2 Notches (x3) (30-025013-20) BK580 (Fibre), 1.62mm, 1 Notch (x3) (30-025007-20)	DR040 ▲○	
VM 82 A/VM 96 A	1779	3	92.00		53/72			
75 1.6L 05/85 → 02/92 14						BC370 (Fibre) (30-024833-10)	DC372 ■ (21-24833-20/0) DC373 ▲■	GC374 GH857 ▲ [12]
AR 06100	1567	4	78.00	SOHC	81/110			
AR 61101	1567	4	78.00		81/110			
75 1.8L 09/85 → 06/89 15						BH850 (Fibre) (30-021835-20)	DC373 ▲■	GH856 (20-21835-01/0) GH857 ▲ [12]
AR 06202	1779	4	80.00	SOHC	85/116			
75 1.8L 09/88 → 02/92 16						BH850 (Fibre) (30-021835-20)	DC373 ▲■	GH856 (20-21835-01/0)
AR 06168	1779	4	80.00	SOHC	88/120			
AR 61102	1779	4	80.00	i.e., SOHC	88/120			
75 1.8L 08/89 → 02/92 17						BH850 (Fibre) (30-021835-20)	DH855 [12]	GH858
AR 61201	1779	4	80.00	i.e.	90/122			
75 1.8L i.e. Turbo 02/86 → 01/90 18						BT360 (Fibre) (30-026016-10)	DT360 (21-26016-20/0)	GT360
75 1.8L Turbo 09/86 → 02/92								
AR 06134	1779	4	80.00	SOHC	155/211			
AR 06158	1779	4	80.00		155/211			
75 2.0L 05/85 → 10/88 19						AN300 (Fibre) (30-024565-10)	CN306 [12] (21-24565-22/0) DC373 ▲■	FN307 (20-24565-01/0) GH857 ▲ [12]
AR 06212	1962	4	84.00	DOHC	94/128			
75 2.0L T.S. 05/85 → 02/92 20						BT350 (Fibre) (30-026280-10) AA5520 1.85mm (30-029640-00)	DT350 ■ (21-26280-20/0)	GT350 AR06166 GT351 AR06224
75 2.0L T.S. 01/87 → 02/92								
AR 06166	1962	4	84.00	i.e., SOHC	107/146			
AR 06224	1962	4	84.00	i.e., SOHC	107- 109/ 146- 148			

								
		JD221 (x2) (31-026835-10) JA899 (x4) (31-026340-10)		JH565	HR363 	 NA5064 35x58x10mm, ACM (50-306562-50)  NA5063 40x56x10mm, ACM  NA5065 62x80x12mm, ACM	KV123 [11] KV124 [11]	 AN300  BC370  BH850  BK570, BP260, BK580  BP990  BT350, AA5520  BT360  JA829  JA840  JA899  JC497  JC928  JD015  JD016  JD017  JD018  JD025  JD221 JD5144 JE696
HBS107  (22-56004B) M14x2.0x137mm (x8) M12x1.75x80mm (x3) M12x1.75x116mm (x3)	JC928  (x3) (31-025852-10) JD5144 (x3) (31-028425-00) JD025  (x3) (31-025849-10)  JF123 (31-027523-00)	JN652					LA246 [37] 	 JF123  JN652  JN806  JN812  JP004  JH565  JJ451  JJ452
	JA840  01/76 → 12/82 JC497  (31-026240-10) 01/83 → 12/84 JA829  (x4) (31-022278-00)  JE696 (32-202195-10)	JP004 (31-022026-20)	JJ452 (MVQ)			 NA5066 (50-305717-00)	KA350 [13] KD383 [91] KV004 [91]	 BT350, AA5520  BT360  JA829  JA840  JA899  JC497  JC928  JD015  JD016  JD017  JD018  JD025  JD221 JD5144 JE696
	JA840  JC497  (31-026240-10) → 12/84 JA829  (x4) (31-022278-00)  JE696 (32-202195-10)	JP004 (31-022026-20)	JJ452 (MVQ)			 NA5066 (50-305717-00)	KA350 [13]	 BT350, AA5520  BT360  JA829  JA840  JA899  JC497  JC928  JD015  JD016  JD017  JD018 JD025 JD221 JD5144 JE696
	JC497  (31-026240-10) JA829  (x4) (31-022278-00)  JE696 (32-202195-10)	JP004 (31-022026-20)	JJ452 (MVQ)			 NA5066 (50-305717-00)		 BT350, AA5520  BT360  JA829  JA840  JA899  JC497  JC928  JD015  JD016 JD017 JD018 JD025 JD221 JD5144 JE696
	JD018  (31-027300-00) JA829  (x4) (31-022278-00)  JE696 (x2) (32-202195-10)	JN806 (MVQ)	JJ452 (MVQ)			 NA5066 (50-305717-00)  NA5068	KD383 [91]	 BT350, AA5520  BT360  JA829  JA840  JA899  JC497  JC928  JD015 JD016 JD017 JD018 JD025 JD221 JD5144 JE696
	JD017  (31-026143-10) JD018  (31-027300-00)	JN806 (MVQ)	JJ452 (MVQ)					 BT350, AA5520  BT360  JA829  JA840  JA899  JC497 JC928 JD015 JD016 JD017 JD018 JD025 JD221 JD5144 JE696
	JC497  (31-026240-10) JA840  01/76 → 12/82 JA829  (x4) (31-022278-00)	JP004 (31-022026-20)	JJ452 (MVQ)			 NA5066 (50-305717-00)		 BT350, AA5520  BT360  JA829  JA840  JA899 JC497 JC928 JD015 JD016 JD017 JD018 JD025 JD221 JD5144 JE696
	JD016  JD015  (x4) (31-027276-00)  JE696 (32-202195-10)	JN812 (31-027274-00)	JJ451 JJ452 (MVQ)	HR363 		 NA5066 (50-305717-00)  NA5068		 BT350, AA5520  BT360  JA829  JA840 JA899 JC497 JC928 JD015 JD016 JD017 JD018 JD025 JD221 JD5144 JE696















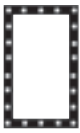





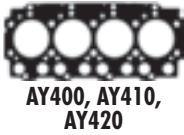

















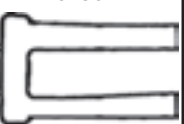



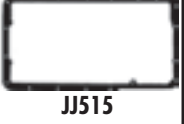























ALFA ROMEO



KW/PS



75 2.0L TD Diesel				05/85 → 09/92		21	AY400 (MLS), 1.42mm, 0 Notches (30-028472-00) BK570 (Fibre), 1.42mm, 0 Notches (x4) (30-025008-20) AY410 (MLS), 1.52mm, 2 Notches (30-028473-00) BP260 (Fibre), 1.52mm, 2 Notches (x4) (30-025013-20) AY420 (MLS), 1.62mm, 1 Notch (30-028474-00) BK580 (Fibre), 1.62mm, 1 Notch (x4) (30-025007-20)	DK570 ▲ [7] (21-25850-21/0)	GK570 ▲ [36] (20-25850-02/0)
VM 80 A	1995	4	88.00	OHV	60/73/ 82/99				
75 2.4L TD Diesel				01/89 → 02/92		22	AY400 (MLS), 1.42mm, 0 Notches (30-028472-00) BK570 (Fibre), 1.42mm, 0 Notches (x4) (30-025008-20) AY410 (MLS), 1.52mm, 2 Notches (30-028473-00) BP260 (Fibre), 1.52mm, 2 Notches (x4) (30-025013-20) AY420 (MLS), 1.62mm, 1 Notch (30-028474-00) BK580 (Fibre), 1.62mm, 1 Notch (x4) (30-025007-20)	DK570 ▲ [7] (21-25850-21/0)	GK570 ▲ [36] (20-25850-02/0)
VM 81 A	2393	4	92.00	OHV	81/110				
75 2.5L V6				05/85 → 04/89		23	BW300 (Fibre) (30-025874-20) BW310 (Fibre) (30-025875-20)	DW300 (21-25874-20/0)	GW300 [93]
AR 01911	2492	6	88.00	SOHC, V6	110- 115/ 150- 156				
AR 01646	2492	6	88.00	V6	110- 116/ 150- 158				
AR 01648	2492	6	88.00	V6	113/154				
75 3.0L V6				01/87 → 02/92		24	BW260 (Fibre) (30-025873-20)	DW260 (21-25873-20/0)	GW260
AR 06120/ AR 06124/AR 61503	2959	6	93.00	i.e., V6	132/ 141/ 180/ 192				
90 1.8L				10/84 → 07/87		25	BH850 (Fibre) (30-021835-20)	DC373 ▲	GH856 (20-21835-01/0) GH857 ▲ [12]
AR 06202	1779	4	80.00	SOHC	85/116				
90 2.0L i.e.				10/84 → 07/87		26	AN300 (Fibre) (30-024565-10)	CN306 [12] (21-24565-22/0) DC373 ▲	FN307 (20-24565-01/0) GH857 ▲ [12]
AR 01713	1962	4	84.00	i.e.	94/128				
AR 06212	1962	4	84.00	DOHC	94/128				
90 2.0L i.e.				10/84 → 07/87		27	BW280 (Fibre) (30-027266-00) BW290 (Fibre) (30-027265-00)	DW280 (21-27265-20/0)	GW280 (20-27265-00/0)
AR 06210	1997	6	80.00	V6	97/132				











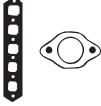

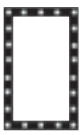























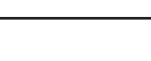













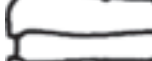



























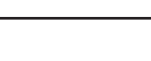

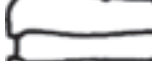































	  				 		                         
HBS105  (22-56001B) M14x2.0x137mm (x10) M12x1.75x80mm (x4) M12x1.75x116mm (x4)	JC928  (31-025852-10) JD5144 (31-028425-00) JD025  (x4) (31-025849-10)  JF123 (31-027523-00)	JN581 (x4) JP067 (31-025850-10)				LA246 	
HBS105  (22-56001B) M14x2.0x137mm (x10) M12x1.75x80mm (x4) M12x1.75x116mm (x4)	JC928  (31-025852-10) JD5144 (31-028425-00) JD025  (x4) (31-025849-10)  JF123 (31-027523-00)	JN581 (x4) JP067 (31-025850-10)				LA246 	
	JD223  (x6) (31-027287-00)	JN808  (31-027281-00) JN807  (31-027280-00)	KV086		 NA5163 (x2) 32x47x10mm, FPM  NA5068		
	JD222  (x2) (31-027279-00) JD223  (x6) (31-027287-00)	JN808  (31-027281-00) JN807  (31-027280-00)	JJ515		 NA5163 (x2) 32x47x10mm, FPM  NA5068		
	JC497  (31-026240-10) →12/84 JA829  (x4) (31-022278-00)  JE696 (32-202195-10)	JP004 (31-022026-20)	JJ452 (MVQ)		 NA5066 (50-305717-00)		
	JA840  JD018  (31-027300-00) JA829  (x4) (31-022278-00)  JE696 (32-202195-10)	JN806 (MVQ)	JJ452 (MVQ)		 NA5066 (50-305717-00)		
	JD224  (x6) (31-028778-00)	JN808  (31-027281-00) JN807  (31-027280-00)					



KW/PS



90 2.4L TD Diesel				10/84 → 07/87	28			DK570▲ [7] (21-25850-21/0)	GK570▲ [36] (20-25850-02/0)
VM 81 A	2393	4	92.00	OHV	81/110	AY400 (MLS), 1.42mm, 0 Notches (30-028472-00) BK570 (Fibre), 1.42mm, 0 Notches (30-025008-20) AY410 (MLS), 1.52mm, 2 Notches (30-028473-00) BP260 (Fibre), 1.52mm, 2 Notches (30-025013-20) AY420 (MLS), 1.62mm, 1 Notch (30-028474-00) BK580 (Fibre), 1.62mm, 1 Notch (30-025007-20)			
90 2.5L i.e. V6				10/84 → 07/87	29			DW300 (21-25874-20/0)	GW300 [93]
AR 01911	2492	6	88.00	SOHC, V6	110- 115/ 150- 156	BW300 (Fibre) (30-025874-20) BW310 (Fibre) (30-025875-20)			
AR 01646	2492	6	88.00	V6	110- 116/ 150- 158				
145 1.4L i.e.				07/94 → 12/96	30			CN355 (21-26481-21/0)	FN355 (20-26481-01/0)
AR 33501	1351	4	80.00		66/89	AA5540 (Fibre) (x2) (30-030087-00) AN350 (Fibre) (x2) (30-026481-00)			
145 1.4L i.e. 16V T.S.				12/96 → 01/01	31			DY390 → 05/98 DY391 (21-28748-21/0) 05/98 → 06/00	GY390 (20-28748-00/0) → 05/98 GY391 (20-28748-01/0) 05/98 → 06/00
AR 33503/AR 38501	1371	4	82.00		76/103	BY390 (Fibre), 1.20mm (30-028748-00) AY510 (Fibre), 1.40mm			
145 1.6L i.e.				10/94 → 12/96	32			DE623 (21-24362-22/0)	GE623 (20-24362-02/0)
AR 33201	1596	4	84.00	i.e.	76/103	BE620 (Fibre) (x2) (30-024362-10)			
145 1.6L i.e. 16V T.S.				12/96 → 01/01	33			DW721 [95] (21-28382-21/0) → 05/98 DW722 (21-28382-22/0) 05/98 → 06/00	GW721 → 05/98 GW722 [97] (20-28382-01/0) 05/98 → 06/00
AR 38201/AR 67601	1598	4	82.00		88/120	AY500 (Fibre) [249] BW720 (Fibre), 1.65mm (30-028382-00)			
145 1.7L i.e. 16V				10/94 → 12/96	34			DT340 (21-27162-20/0)	GT340 (20-27162-00/0)
AR 33401	1717	4	87.00	i.e.	95/98/ 130/ 133	AA5550 (Fibre) (x2) [249] BT340 (Graphite) (x2) (30-027162-00)			
145 1.8L i.e. 16V				03/98 → 01/01	35			DW721 [95] (21-28382-21/0) → 05/98 DW722 (21-28382-22/0) 05/98 → 06/00 CA5420 [98] (21-29064-20/0) 06/00 →	GW721 → 05/98 GW722 [96] (20-28382-01/0) 05/98 → 06/00
AR 38401/AR 67106	1747	4	82.00		103/140	AY500 (Fibre) [249] BW720 (Fibre), 1.65mm (30-028382-00)			
AR 32201	1747	4	82.00		106/144				

								
HBS105  [22-56001B] M14x2.0x137mm (x10) M12x1.75x80mm (x4) M12x1.75x116mm (x4)	JC928  (31-025852-10) JD5144 (31-028425-00) JD025  (x4) (31-025849-10)  JF123 (31-027523-00)	JN581 (x4) JP067 (31-025850-10)						 AA5540, AN350, BE620, AA5550  AY400, AY410, AY420  AY500  AY510  BK570, BP260, BK580  BT340  BW300  BW310  BW720  BY390  JA899  JC928  JD014  JD025  JD221  JD223  JD271  JD273
	JD223  (x6) (31-027287-00)	JN808  (31-027281-00) JN807  (31-027280-00)			NA5163 (x2) 32x47x10mm, FPM NA5068			 JD466  JD5144  JD565  JF123  HL700  JM5002  JN581  JN588  JN807  JN808  JN810  JN811  JP067  JJ450
	JD221 (x2) (31-026835-10) JA899  (x4) (31-026340-10)	JN588 (x2) (31-025164-10)	JJ450	HR363 	NA5064 35x58x10mm, ACM (50-306562-50) NA5063  40x56x10mm, ACM NA5065  62x80x12mm, ACM	HJ287 [39]  JR349 [11] KV123 [11] KV124 [11]		 BW310  BW720  BY390
HBS262  [22-56008B] M10x1.25x220mm (x10)	JD466  (Steel) 103 HP Only JD273  (31-027729-00) (MLS)	JM5002 (50-030085-00) 05/98 → HL700  [24-30088-00/0] →05/98	HR354 [94]	HR800 	NA5053 30x42x7mm, FPM (50-319488-00) NA5070  31x41x7mm, FPM (50-319524-00) NF888  [3] 93x139.7x12mm, FPM (50-319526-00) 05/98 →	HL5031 [245] 		 BY390  JA899  JC928  JD014  JD025  JD221  JD223  JD271  JD273
	JD221 (x2) (31-026835-10) JA899  (x4) (31-026340-10)	JN588 (x2) (31-025164-10)	JJ450	HR363 	NA5064 35x58x10mm, ACM (50-306562-50)	JR349 [11] KV123 [11] KV124 [11]		 JA899  JC928  JN810  JN811  JP067  JJ450
HBS132  [22-17015B] M10x1.25x254mm (x10)	JD271  (31-027450-10) (Metal) JD273  (31-027729-00) (MLS)	JM5002 (50-030085-00) 05/98 → HL700  [24-30088-00/0] →05/98	HR354 [94]	HR800 	NA5053 30x42x7mm, FPM (50-319488-00) NA5069 55x68x8mm, FPM (50-319515-00) NA5070  31x41x7mm, FPM (50-319524-00) NF888  [3] 93x139.7x12mm, FPM (50-319526-00)	HL5030 [245]  HJ283 [39] 		 JD014  JD025  JD221  JD223  JD271  JD273
	JD014  (x4) (31-028772-00) JD565  (x4) (31-026319-00)	JN811  (50-028774-00) JN810  (50-028773-00)	JJ450	HR800 	NA5063  40x56x10mm, ACM NA5065  62x80x12mm, ACM			 JD221  JD223  JD271  JD273
HBS132  [22-17015B] M10x1.25x254mm (x10)	JD271  (31-027450-10) (Metal) JD273  (31-027729-00) (MLS)	JM5002 (50-030085-00) 05/98 → HL700  [24-30088-00/0] →05/98	HR354 [94]	HR800 	NA5053 30x42x7mm, FPM (50-319488-00) NA5069 55x68x8mm, FPM (50-319515-00) NA5070  31x41x7mm, FPM (50-319524-00) NF888  [3] 93x139.7x12mm, FPM (50-319526-00)	HL5030 [245]  HJ283 [39] 		 JD271  JD273











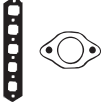

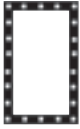













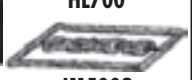

































































ALFA ROMEO



KW/PS



145 1.9L JTD Diesel				02/99 → 01/01		36	AY520 (MLS), 1.60mm, 0 Holes (30-029023-10) AY530 (MLS), 1.70mm, 1 Hole (30-029024-10) AY540 (MLS), 1.80mm, 2 Holes (30-029025-10)		CY550▲ [99] (21-29023-20/0)	FY550▲ (20-29023-00/0)
AR 32302	1910	4	82.00	Direct Injection, SOHC		77/105				
145 1.9L TD Diesel				10/94 → 02/99		37	BR680 (Graphite), 1.65mm BV680 (Fibre), 1.67mm, 0 Notches (30-026296-10) BV690 (Fibre), 1.75mm, 1 Notch BV700 (Fibre), 1.85mm, 2 Notches (30-027859-00) BW980 (Fibre), 1.93mm, 3 Notches		DV680▲ (21-25142-26/0)	EV684 (22-25142-00/0) GV680▲ [100]
AR 33601/AR 67501	1929	4	82.60			66/68/ 90/92				
145 2.0L 16V Quadrifoglio				03/98 → 01/01		38	AY490 (Fibre) [249] BW710 (Fibre), 1.65mm (30-028420-00) AA5420 (MLS), 0.38mm (30-029064-00) 06/00 →		DW711 (21-28420-21/0) → 05/98 DW712 [101] (21-28420-22/0) 05/98 → 06/00 CA5420 [98] (21-29064-20/0) 06/00 →	EA5420 (22-29064-00/0) GW711 (20-28420-00/0) → 05/98 GW712 [101] (20-28420-01/0) 05/98 → 06/00
AR 32301	1970	4	83.00			110/ 121/ 150/ 165				
145 2.0L 16V T.S.				10/95 → 01/01		39	AY490 (Fibre) [249] BW710 (Fibre), 1.65mm (30-028420-00)		DW710 (21-28420-20/0)	GW713 (20-28420-02/0)
AR 67204	1970	4	83.00			110/150				
146 1.4L i.e. 16V T.S.				11/96 → 01/01		40	BY390 (Fibre), 1.20mm (30-028748-00) AY510 (Fibre), 1.40mm		DY390 → 05/98 DY391 (21-28748-21/0) 05/98 → 06/00	GY390 (20-28748-00/0) → 05/98 GY391 (20-28748-01/0) 05/98 → 06/00
AR 33503/AR 38501	1371	4	82.00			76/103				
146 1.6L i.e. 16V T.S.				11/96 → 01/01		41	AY500 (Fibre) [249] BW720 (Fibre), 1.65mm (30-028382-00)		DW721 [95] (21-28382-21/0) → 05/98 DW722 (21-28382-22/0) 05/98 → 06/00	GW721 GW722 [96] (20-28382-01/0) 05/98 → 06/00
AR 38201/AR 67601	1598	4	82.00			88/120				
146 1.7L i.e. 16V				12/94 → 12/96		42	AA5550 (Fibre) (x2) [249] BT340 (Graphite) (x2) (30-027162-00)		DT340 (21-27162-20/0)	GT340 (20-27162-00/0)
AR 33401	1717	4	87.00	i.e.		95/98/ 130/ 133				
146 1.8L i.e. 16V T.S.				11/96 → 01/01		43	AY500 (Fibre) [249] BW720 (Fibre), 1.65mm (30-028382-00)		DW721 [95] (21-28382-21/0) → 05/98 CA5420 [98] (21-29064-20/0) 06/00 →	EA5420 (22-29064-00/0) 06/00 → GW721 GW722 [96] (20-28382-01/0) 05/98 → 06/00
AR 38401/AR 67106 AR 32201	1747 1747	4 4	82.00 82.00			103/140 106/144				

								
HBS227  (22-170188) M12x1.25x218mm (x10)	JD580  (Felt) →02/00 JA5035  (31-029407-00) 02/00 → JD468  (31-028377-00) (MLS)	JP063		HR363 	NA5053 30x42x7mm, FPM (50-319488-00) NA5070  31x41x7mm, FPM (50-319524-00) NF888  [3] 93x139.7x12mm, FPM (50-319526-00)	HL5031 [245]  KA845 [13]	 AA5550  HL700  AY490  JM5002  AY500  JN459  AY510  JN810  AY520, AY530, AY540  JN811  BR680  JP063  BT340  BV680, BV690, BV700, BW980  JJ298  BW710, AA5420, BW720  JJ398  BY390  JA5035  JC738  JD014  JD271  JD272  JD273  JD466  JD468  HJ283 [39]  JD565  JD580	
HBS095  (22-17007B) M12x1.25x133mm (x10)	JC738 (31-026290-10)	JN459 (31-025142-10)	JJ398 (31-027379-00) →Ch.9185 JJ298 Ch.9185 →	HR596 	NA5187 30x52x7mm, ACM (50-319492-00) NB742  30x43x8mm, ACM (50-319408-00) NB732  74x90x10mm, FPM NA5062  74x90x10mm, ACM	KT465 [54]		
HBS132  (22-17015B) M10x1.25x254mm (x10)	JD271  (31-027450-10) (Metal) JD273  (31-027729-00) (MLS)	JM5002 (50-030085-00) 05/98 → HL700  (24-30088-00/0) →05/98	HR354 [94]		NA5053 30x42x7mm, FPM (50-319488-00) NA5069 55x68x8mm, FPM (50-319515-00) NA5070  31x41x7mm, FPM (50-319524-00) NF888  [3] 93x139.7x12mm, FPM (50-319526-00)	HL5030 [245]  KL476 [70]		
HBS132  (22-17015B) M10x1.25x254mm (x10)	JD271  (31-027450-10) (Metal) JC738 (31-026290-10) JD272  (31-028558-00)	JN459 (31-025142-10) HL700  (24-30088-00/0) →05/98	JJ398 (31-027379-00) →Ch.9185 JJ298 Ch.9185 →	HR800 	NA5053 30x42x7mm, FPM (50-319488-00) NA5069 55x68x8mm, FPM (50-319515-00) NA5070  31x41x7mm, FPM (50-319524-00) NF888  [3] 93x139.7x12mm, FPM (50-319526-00)	HL5030 [245]  KT465 [54]		
HBS262  (22-56008B) M10x1.25x220mm (x10)	JD466  (Steel) 103 HP Only JD273  (31-027729-00) (MLS)	JM5002 (50-030085-00) 05/98 → HL700  (24-30088-00/0) →05/98	HR354 [94]	HR800 	NA5053 30x42x7mm, FPM (50-319488-00) NA5070  31x41x7mm, FPM (50-319524-00) NF888  [3] 93x139.7x12mm, FPM (50-319526-00) 05/98 →	HL5031 [245] 		
HBS132  (22-17015B) M10x1.25x254mm (x10)	JD271  (31-027450-10) (Metal) JD273  (31-027729-00) (MLS)	JM5002 (50-030085-00) 05/98 → HL700  (24-30088-00/0) →05/98	HR354 [94]		NA5053 30x42x7mm, FPM (50-319488-00) NA5069 55x68x8mm, FPM (50-319515-00) NA5070  31x41x7mm, FPM (50-319524-00) NF888  [3] 93x139.7x12mm, FPM (50-319526-00)	HL5030 [245] 		
HBS263	JD014  (x4) (31-028772-00) JD565  (x4) (31-026319-00)	JN811  (50-028774-00) JN810  (50-028773-00)	JJ450	HR800 	NA5063  40x56x10mm, ACM NA5065  62x80x12mm, ACM			
HBS132  (22-17015B) M10x1.25x254mm (x10)	JD271  (31-027450-10) (Metal) JD273  (31-027729-00) (MLS)	JM5002 (50-030085-00) 05/98 → HL700  (24-30088-00/0) →05/98	HR354 [94]		NA5053 30x42x7mm, FPM (50-319488-00) NA5069 55x68x8mm, FPM (50-319515-00) NA5070  31x41x7mm, FPM (50-319524-00) NF888  [3] 93x139.7x12mm, FPM (50-319526-00)	HL5030 [245]  HJ283 [39] 		











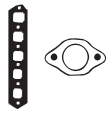

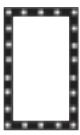

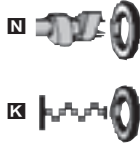









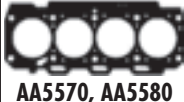

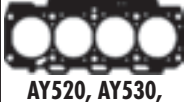

















































ALFA ROMEO



KW/PS



146 1.9L JTD Diesel				02/99 → 01/01	44			CY550▲ [99] (21-29023-20/0)	FY550▲ (20-29023-00/0)
AR 32302	1910	4	82.00	Direct Injection, SOHC	77/105	AY520 (MLS), 1.60mm, 0 Holes (30-029023-10) AY530 (MLS), 1.70mm, 1 Hole (30-029024-10) AY540 (MLS), 1.80mm, 2 Holes (30-029025-10)			
146 1.9L TD Diesel				12/94 → 02/99	45			DV680▲ (21-25142-26/0)	ER680 GV680▲ [100]
AR 33601/AR 67501	1929	4	82.60		66/68/ 90/92	BR680 (Graphite), 1.65mm BV680 (Fibre), 1.67mm, 0 Notches (30-026296-10) BV690 (Fibre), 1.75mm, 1 Notch BV700 (Fibre), 1.85mm, 2 Notches (30-027859-00) BW980 (Fibre), 1.93mm, 3 Notches			
146 2.0L 16V Quadrifoglio				03/98 → 01/01	46			DW711 (21-28420-21/0) → 05/98 DW712 [101] (21-28420-22/0) 05/98 → 06/00 CA5420 [98] (21-29064-20/0) 06/00 →	EA5420 (22-29064-00/0) GW711 (20-28420-00/0) → 05/98 GW712 [101] (20-28420-01/0) 05/98 → 06/00
AR 32301	1970	4	83.00		110- 121/ 150- 165	AY490 (Fibre) [249] BW710 (Fibre), 1.65mm (30-028420-00) AA5420 (MLS), 0.38mm (30-029064-00) 06/00 →			
146 2.0L 16V T.S.				10/95 → 01/01	47			DW710 (21-28420-20/0)	GW713 (20-28420-02/0)
AR 67204	1970	4	83.00		110/150	AY490 (Fibre) [249] BW710 (Fibre), 1.65mm (30-028420-00)			
147 1.6L 16V T.SPARK 147 1.6L 16V T.SPARK ECO				01/01 → 01/01 →	48			CA5420 [98] (21-29064-20/0) 06/00 →	EA5420 (22-29064-00/0) 06/00 →
AR 37203 AR 32104	1598 1598	4 4	82.00 82.00	DOHC	76/103 88/120	AA5420 (MLS), 0.38mm (30-029064-00) 06/00 →			
147 1.9L JTD Diesel				04/01 →	49			CA5560▲ (21-29093-21/0) CA5561▲ (21-29093-20/0) Eng.408111 →	FA5560▲ (20-29095-00/0)
937 A2.000	1910	4	82.00		85/116	AG7390 (MLS), 0.82mm (30-030144-00) AA5570 (MLS), 0.92mm, 1 Hole (30-029094-10) AA5580 (MLS), 1.02mm, 2 Holes (30-029095-10)			
147 1.9L JTD Diesel				06/03 →	50			CA5560▲ (21-29093-21/0) → Eng.408111 CA5561▲ (21-29093-20/0) Eng.408111 →	EE5181 (22-29832-01/0) FA5560▲ (20-29095-00/0)
182 B9.000	1910	4	82.00	Direct Injection, SOHC	74-77/ 101- 105	AG7390 (MLS), 0.82mm (30-030144-00) AA5570 (MLS), 0.92mm, 1 Hole (30-029094-10) AA5580 (MLS), 1.02mm, 2 Holes (30-029095-10)			

      							
HBS227  (22-170188) M12x1.25x218mm (x10)	JD580  (Felt) →02/00 JA5035  (31-029407-00) 02/00 → JD468  (31-028377-00) (MLS)	JP063		HR363 	NA5053 30x42x7mm, FPM (50-319488-00) NA5070  31x41x7mm, FPM (50-319524-00) NF888  [3] 93x139.7x12mm, FPM (50-319526-00)	HL5031 [245]  KA845 [13]	 AA5570, AA5580  AY490  AY520, AY530, AY540  BR680  BV680, BV690, BV700, BW980  BW710, AA5420  JA5035  JC738  JD271  JD272  JD273  JD466  JD468  JD580  HL700  JM5002  JM5028  JM5204  JN459
HBS095  (22-17007B) M12x1.25x133mm (x10)	JC738 (31-026290-10)	JN459 (31-025142-10)	JJ398 (31-027379-00) →Ch.9185 JJ298 Ch.9185 →	HR596 	NA5187 30x52x7mm, ACM (50-319492-00) NB742  30x43x8mm, ACM (50-319408-00) NB732  74x90x10mm, FPM NA5062  74x90x10mm, ACM	KT465 [54]	
HBS132  (22-17015B) M10x1.25x254mm (x10)	JD271  (31-027450-10) (Metal) JD273  (31-027729-00) (MLS)	JM5002 (50-030085-00) 05/98 → HL700  (24-30088-00/0) →05/98	HR354 [94]		NA5053 30x42x7mm, FPM (50-319488-00) NA5069 55x68x8mm, FPM (50-319515-00) NA5070  31x41x7mm, FPM (50-319524-00) NF888  [3] 93x139.7x12mm, FPM (50-319526-00)	HL5030 [245]  KL476 [70]	
HBS132  (22-17015B) M10x1.25x254mm (x10)	JD271  (31-027450-10) (Metal) JD272  (31-028558-00)	HL700  (24-30088-00/0) →05/98	JJ298 JJ398 (31-027379-00)	HR800 	NA5053 30x42x7mm, FPM (50-319488-00) NA5069 55x68x8mm, FPM (50-319515-00) NA5070  31x41x7mm, FPM (50-319524-00) NF888  [3] 93x139.7x12mm, FPM (50-319526-00)	HL5030 [245]  KT465 [54]	
HBS262  (22-56008B) M10x1.25x220mm (x10)	JD271  (31-027450-10) (Metal) JD466  (Steel) 103 HP Only JD273  (31-027729-00) (MLS)	JM5002 (50-030085-00) 05/98 → HL700  (24-30088-00/0) →05/98			NA5053 30x42x7mm, FPM (50-319488-00) NA5069 55x68x8mm, FPM (50-319515-00) NA5070  31x41x7mm, FPM (50-319524-00) NF888  [3] 93x139.7x12mm, FPM (50-319526-00)	HL5030 [245] 	
HBS227  (22-170188) M12x1.25x218mm (x10)	JA5035  (31-029407-00) (Metal) JD580  (Felt) JD468  (31-028377-00) (MLS)	JM5028 (31-029635-00) →Eng.4081110 JM5204 (50-029935-00) Eng.4081112 →		HR363 	NA5053 30x42x7mm, FPM (50-319488-00) NA5070  31x41x7mm, FPM (50-319524-00) NF888  [3] 93x139.7x12mm, FPM (50-319526-00)	HL5031 [245] 	
HBS227  (22-170188) M12x1.25x218mm (x10)	JA5035  (31-029407-00) JD580  JD468  (31-028377-00) (MLS)			HR363 	NA5053 30x42x7mm, FPM (50-319488-00) NA5070  31x41x7mm, FPM (50-319524-00) NF888  [3] 93x139.7x12mm, FPM (50-319526-00)	HL5031 [245] 	







ALFA ROMEO

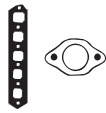

KW/PS

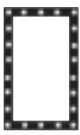

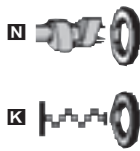
147 1.9L JTD 16V Diesel				11/02 →		51		AD5840 (MLS), 0.82mm, 0 Holes (30-029766-00)		CD5840▲ (21-29766-20/0)		EE5181 (22-29832-01/0)	
192 A5.000	1910	4	82.00	Direct Injection, DOHC		103/140		AD5850 (MLS), 0.92mm, 1 Hole (30-029767-00)					
								AD5860 (MLS), 1.02mm, 2 Holes (30-029768-00)					
147 1.9L JTDM 16V Diesel				07/05 →		52		AD5840 (MLS), 0.82mm, 0 Holes (30-029766-00)		CD5840▲ (21-29766-20/0)		EE5181 (22-29832-01/0)	
937 A5.000	1910	4	82.00	Direct Injection, DOHC		110/150		AD5850 (MLS), 0.92mm, 1 Hole (30-029767-00)					
								AD5860 (MLS), 1.02mm, 2 Holes (30-029768-00)					
147 1.9L JTD 16V Diesel				09/03 →09/04		53							
192 B1.000	1910	4	82.00	Direct Injection, DOHC		100/136							
937 A4.000	1910	4	82.00			103/140							
147 2.0L 16V T.SPARK				01/01 →		54		AD5950 (MLS), 0.45mm (30-029777-00)		CA5420[98] (21-29064-20/0)		EA5420 (22-29064-00/0)	
AR 32310	1970	4	83.00			110/150		2832058		06/00 →			
								AA5420 (MLS), 0.38mm (30-029064-00)					
								06/00 →					
147 3.2L GTA				02/03 →		55		BT380 (Fibre), 1.65mm ☒ (30-027519-00)		CY640 (21-27518-20/0)		FY640	
932 A.000	3179	6	93.00	DOHC, V6		184/250		AY640 (Fibre), 1.65mm ☒ (30-027518-10)					
155 16V T.S.				05/96 →01/98		56		AY500 (Fibre) [249]		DW721 [95] (21-28382-21/0)		GW721	
AR 67601	1598	4	82.00			88/120		BW720 (Fibre), 1.65mm (30-028382-00)		→05/98		GW724	
										DW722 (21-28382-22/0)		GW722 [96] (20-28382-01/0)	
										05/98 →06/00		05/98 →06/00	
155 1.7L T.S.				04/93 →04/96		57		BW410 (Fibre) (30-027271-00)		DW410 (21-27271-20/0)		GW410 (20-27271-00/0)	
AR 67103/AR 67105	1748	4	83.40	i.e.		85/116							
155 1.7L T.S. 16V				05/96 →12/97		58		AY500 (Fibre) [249]		DW721 [95] (21-28382-21/0)		EA5420 (22-29064-00/0)	
AR 67106	1747	4	82.00			103/140		BW720 (Fibre), 1.65mm (30-028382-00)		→05/98		GW721 →05/98	
										DW722 (21-28382-22/0)		GW724	
										05/98 →06/00		GW722 [96] (20-28382-01/0)	
										CA5420[98] (21-29064-20/0)		05/98 →06/00	
										01/00 →			
155 1.8L T.S.				02/92 →12/97		59		BW410 (Fibre) (30-027271-00)		DW410 (21-27271-20/0)		GW410 (20-27271-00/0)	
AR 67402	1748	4	83.40	i.e.		85/116							
AR 67101/AR 67102	1773	4	84.00	i.e.		93/126							
155 1.9L TD Diesel				04/93 →12/97		60		BR680 (Graphite), 1.65mm		DV680▲ (21-25142-26/0)		GV680▲ [100]	
AR 67501	1929	4	82.60			66/68/ 90/92		BV680 (Fibre), 1.67mm, 0 Notches (30-026296-10)					
								BV690 (Fibre), 1.75mm, 1 Notch					
								BV700 (Fibre), 1.85mm, 2 Notches (30-027859-00)					
								BW980 (Fibre), 1.93mm, 3 Notches					

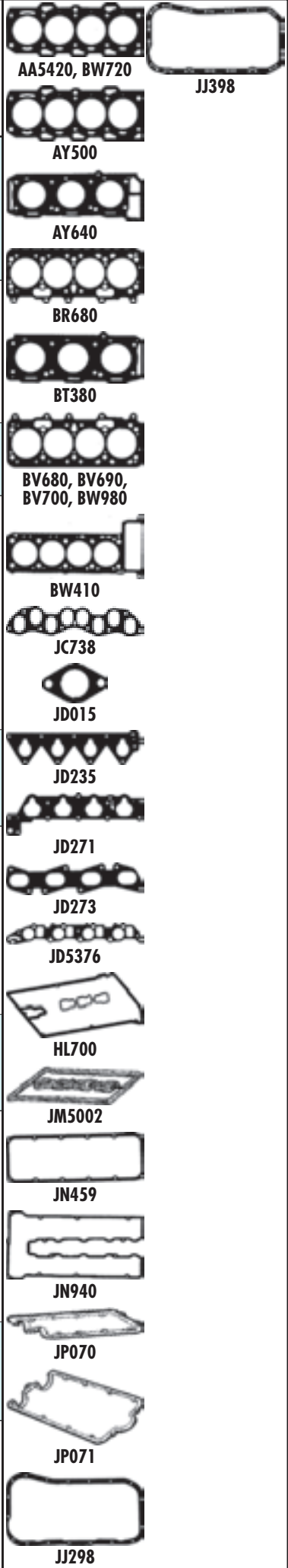
								
HBS370 ® (22-17026B) M12x1.25x225mm (x10)	JD5376 ■ (31-029969-00)	JM7055 (Steel Elastomer)		HR5095 ■	NA5053 30x42x7mm, FPM (50-319488-00) NA5070 ■ 31x41x7mm, FPM (50-319524-00) NF888 ■ [3] 93x139.7x12mm, FPM (50-319526-00)	HL5031 [245]■		AA5420, BW720 AY500 AY640 BR680 BT380 BV680, BV690, BV700, BW980 BW410 JC738 JD015 JD235 JD271 JD273 JD5376 HL700 JM5002 JN459 JN940 JP070 JP071 JJ298
HBS370 ® (22-17026B) M12x1.25x225mm (x10)	JD5376 ■ (31-029969-00)	JM7055 (Steel Elastomer)		HR5095 ■				
		JM7055 (Steel Elastomer)		HR5095 ■				
HBS132 ® (22-17015B) M10x1.25x254mm (x10)		JM5002 (50-030085-00) 05/98 →			NA5053 30x42x7mm, FPM (50-319488-00) NA5069 55x68x8mm, FPM (50-319515-00) NA5070 ■ 31x41x7mm, FPM (50-319524-00) NB825 ■ 30x43x8mm, FPM (50-306773-50) NF888 ■ [3] 93x139.7x12mm, FPM (50-319526-00)	HL5030 [245]■		
		JP071 ■ JP070 ■		HR800 ■	NA5163 (x4) 32x47x10mm, FPM NA5068			
HBS132 ® (22-17015B) M10x1.25x254mm (x10)	JD271 ■ (31-027450-10) (Metal) JD273 ■ (31-027729-00) (MLS)	JM5002 (50-030085-00) 05/98 → HL700 ■ (24-30088-00/0)	HR354 [94]		NA5053 30x42x7mm, FPM (50-319488-00) NA5069 55x68x8mm, FPM (50-319515-00) NA5070 ■ 31x41x7mm, FPM (50-319524-00) NF888 ■ [3] 93x139.7x12mm, FPM (50-319526-00)	HL5030 [245]■ HJ283 [39]■		
	JD235 ■ (31-028775-00) JD015 ■ (x4) (31-027276-00)	JN940 (50-028776-00)		HR363 ■	NA5163 32x47x10mm, FPM NA5068			
HBS132 ® (22-17015B) M10x1.25x254mm (x10)	JD271 ■ (31-027450-10) (Metal) JD273 ■ (31-027729-00) (MLS)	JM5002 (50-030085-00) 05/98 → HL700 ■ (24-30088-00/0) →05/98	HR354 [94]		NA5053 30x42x7mm, FPM (50-319488-00) NA5069 55x68x8mm, FPM (50-319515-00) NA5070 ■ 31x41x7mm, FPM (50-319524-00) NF888 ■ [3] 93x139.7x12mm, FPM (50-319526-00)	HL5030 [245]■ HJ283 [39]■		
	JD235 ■ (31-028775-00) JD015 ■ (x4) (31-027276-00)	JN940 (50-028776-00)		HR363 ■	NA5163 32x47x10mm, FPM NA5068			
HBS095 ® (22-17007B) M12x1.25x133mm (x10)	JC738 (31-026290-10)	JN459 (31-025142-10)	JJ398 (31-027379-00) →Ch.9185 JJ298 Ch.9185 →	HR363 ■ HR596 ■	NA5187 30x52x7mm, ACM (50-319492-00) NB742 ■ 30x43x8mm, ACM (50-319408-00) NB732 ■ 74x90x10mm, FPM NA5062 ■ 74x90x10mm, ACM	KT465 [54]		











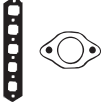

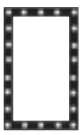

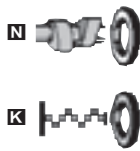





























































ALFA ROMEO



KW/PS



155 2.0L 16V Turbo Q4				01/92 → 12/97		61	BT440 (Fibre) [30-026647-30]	DT447 [21-26647-27/0]	GT447
AR 67203	1995	4	84.00	Injection		137-140/ 186-190			
155 2.0L T.S.				02/92 → 02/95		62	BW410 (Fibre) [30-027271-00]	DW410 [21-27271-20/0]	GW410 [20-27271-00/0]
AR 67202	1970	4	83.00			110/150			
155 2.0L T.S.				02/92 → 04/93		63	BW410 (Fibre) [30-027271-00]	DW410 [21-27271-20/0]	GW410 [20-27271-00/0]
AR 67201	1995	4	84.00	Injection		107/146			
155 2.0L T.S. 16V				03/95 → 12/97		64	AY490 (Fibre) [249] BW710 (Fibre), 1.65mm [30-028420-00]	DW710 [21-28420-20/0]	GW713 [20-28420-02/0]
AR 67204	1970	4	83.00			110/150			
155 2.5L TD Diesel				04/93 → 12/97		65	AY400 (MLS), 1.42mm, 0 Notches [30-028472-00] BK570 (Fibre), 1.42mm, 0 Notches (x4) [30-025008-20] AY410 (MLS), 1.52mm, 2 Notches [30-028473-00] BP260 (Fibre), 1.52mm, 2 Notches (x4) [30-025013-20] AY420 (MLS), 1.62mm, 1 Notch [30-028474-00] BK580 (Fibre), 1.62mm, 1 Notch (x4) [30-025007-20]	DK570▲ [7] [21-25850-21/0] → 01/95 DK573▲ [105] [21-28472-20/0]	GK572▲ [8] [20-25850-01/0] → 01/95 GK573▲ [8] [20-28472-00/0]
VM 07 B/VM 31 B	2500	4	92.00	SOHC		92/125			
155 2.5L V6				02/92 → 12/97		66	BW300 (Fibre) [30-025874-20] BW310 (Fibre) [30-025875-20]	DW301	GW301
AR 67301/ AR 67302/AR 67303	2492	6	88.00	V6		121/165			
156 1.6L 16V T.SPARK				05/00 → 05/06		67	AA5420 (MLS), 0.38mm [30-029064-00]	CA5420 [98] [21-29064-20/0]	EA5420 [22-29064-00/0]
AR 32102/ AR 32103/ AR 32104/AR 67601	1598	4	82.00			88/120			
156 1.6L 16V T.SPARK				09/97 → 09/05		68	AY500 (Fibre) [249] BW720 (Fibre), 1.65mm [30-028382-00]	DW721 [95] [21-28382-21/0] → 05/98 DW722 [21-28382-22/0] 05/98 → 06/00	GW724 GW722 [96] [20-28382-01/0] 05/98 → 06/00
AR 32102/ AR 32103/ AR 32104/AR 67601	1598	4	82.00			88/120			

								
HBS093  (22-17005B) M10x1.25x172mm (x10)	JD151 (31-027331-00) JD152  (31-027272-00)	JN928 [102] (50-027319-00)	JJ413 (31-027315-00)		NA5053 30x42x7mm, FPM (50-319488-00) NB825  30x43x8mm, FPM (50-306773-50) NB732  74x90x10mm, FPM NA5062  74x90x10mm, ACM	JS081 [11] KT639 [11]		 AY400, AY410, AY420  JD273  JD5144  AY490  HL700  AY500  JM5002  BK570, BP260, BK580  JN807  BT440  JN808  BW300  JN928  BW310  JN940  BW410  JP067  BW710, AA5420, BW720  JP068  JD015  JJ413  JD025  JD151  JD152  JD222  JD223  JD235  JD271  JD272
HBS132  (22-17015B) M10x1.25x254mm (x10)	JD235  (31-028775-00) JD015  (31-027276-00)	JN940 (50-028776-00)		HR363 	NA5068			
HBS132  (22-17015B) M10x1.25x254mm (x10)	JD235  (31-028775-00) JD015  (31-027276-00)	JN940 (50-028776-00)		HR363 	NA5068 NA5065  62x80x12mm, ACM			
HBS132  (22-17015B) M10x1.25x254mm (x10)	JD271  (31-027450-10) (Metal) JD272  (31-028558-00)	HL700  (24-30088-00/0) →05/98			NA5053 30x42x7mm, FPM (50-319488-00) NA5069 55x68x8mm, FPM (50-319515-00) NA5070  31x41x7mm, FPM (50-319524-00) NF888  [3] 93x139.7x12mm, FPM (50-319526-00)	HL5030 [245] 		
HBS105  (22-56001B) M14x2.0x137mm (x10) M12x1.75x80mm (x4) M12x1.75x116mm (x4) →12/92 HBS108  (22-56003B) M14x2.0x137mm (x10) M12x1.75x115mm (x4) M12x1.75x79.5mm (x4) 01/93→	JD5144 (31-028425-00) JD025  (x4) (31-025849-10)	JP067 (31-025850-10) →01/95 JP068 (31-029626-00)						
	JD222  (x2) (31-027279-00) JD223  (x6) (31-027287-00)	JN808  (31-027281-00) JN807  (31-027280-00)			NJ951 (x2) 32x50x8mm, FPM NA5068	KA738 [13]		
HBS262  (22-56008B) M10x1.25x220mm (x10)	JD271  (31-027450-10) (Metal) JD273  (31-027729-00) (MLS)				NA5053 30x42x7mm, FPM (50-319488-00) NA5069 55x68x8mm, FPM (50-319515-00) NA5070  31x41x7mm, FPM (50-319524-00) NF888  [3] 93x139.7x12mm, FPM (50-319526-00)	HL5030 [245]  KL476 [70]		
HBS132  (22-17015B) M10x1.25x254mm (x10)	JD271  (31-027450-10) (Metal) JD273  (31-027729-00) (MLS)	JM5002 (50-030085-00) 05/98→ HL700  (24-30088-00/0) →05/98	HR354 [94]		NA5053 30x42x7mm, FPM (50-319488-00) NA5069 55x68x8mm, FPM (50-319515-00) NA5070  31x41x7mm, FPM (50-319524-00) NF888  [3] 93x139.7x12mm, FPM (50-319526-00)	HL5030 [245]  HJ283 [39] 		











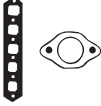

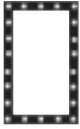

















































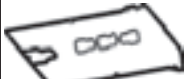

















ALFA ROMEO



KW/PS



156 1.8L 16V T.SPARK				09/97 → 10/00	69	AY500 (Fibre) [249]	DW721 [95]	GW721
AR 32201	1747	4	82.00		106/144	BW720 (Fibre), 1.65mm (30-028382-00)	(21-28382-21/0) →05/98 DW722 (21-28382-22/0) 05/98 →06/00	GW722 [96] (20-28382-01/0) 05/98 →06/00
156 1.8L 16V T.SPARK				10/00 → 05/06	70	AA5420 (MLS), 0.38mm (30-029064-00)	CA5420 [98]	EA5420
AR 32205	1747	4	82.00		103/140		(21-29064-20/0)	(22-29064-00/0)
156 1.9L JTD Diesel				09/97 → 10/00	71	AY520 (MLS), 1.60mm, 0 Holes (30-029023-10)	CY550▲	FY550▲
AR 32302	1910	4	82.00	Direct Injection, SOHC	77/105	AY530 (MLS), 1.70mm, 1 Hole (30-029024-10)	(21-29023-20/0)	(20-29023-00/0)
						AY540 (MLS), 1.80mm, 2 Holes (30-029025-10)		
156 1.9L JTD Diesel				10/00 → 05/01	72	AG7390 (MLS), 0.82mm (30-030144-00)	CA5560▲	EE5181
AR 37101	1910	4	82.00	Direct Injection	73-103/ 100- 140	AA5570 (MLS), 0.92mm, 1 Hole (30-029094-10)	(21-29093-21/0) →Eng.4081111	(22-29832-01/0)
						AA5580 (MLS), 1.02mm, 2 Holes (30-029095-10)	CA5561▲	(20-29095-00/0)
							(21-29093-20/0)	
156 1.9L JTD Diesel				05/01 → 05/06	73	AG7390 (MLS), 0.82mm (30-030144-00)	CA5560▲	FA5560▲
937 A2.000	1910	4	82.00		85/116	AA5570 (MLS), 0.92mm, 1 Hole (30-029094-10)	(21-29093-21/0)	(20-29095-00/0)
						AA5580 (MLS), 1.02mm, 2 Holes (30-029095-10)		
156 1.9L JTD Diesel				11/02 → 05/06	74	AD5840 (MLS), 0.82mm, 0 Holes (30-029766-00)	CD5840▲	EE5181
192 B1.000	1910	4	82.00	Direct Injection, DOHC	100/136	AD5850 (MLS), 0.92mm, 1 Hole (30-029767-00)	(21-29766-20/0)	(22-29832-01/0)
937 A4.000	1910	4	82.00		103/140	AD5860 (MLS), 1.02mm, 2 Holes (30-029768-00)		
937 A5.000	1910	4	82.00	Direct Injection, DOHC	110/150			
156 1.9L JTD 16V Diesel				11/02 → 05/06	75	AD5840 (MLS), 0.82mm, 0 Holes (30-029766-00)	CD5840▲	EE5181
192 A5.000	1910	4	82.00	Direct Injection, DOHC	103/140	AD5850 (MLS), 0.92mm, 1 Hole (30-029767-00)	(21-29766-20/0)	(22-29832-01/0)
937 A5.000	1910	4	82.00	Direct Injection, DOHC	110/150	AD5860 (MLS), 1.02mm, 2 Holes (30-029768-00)		
156 2.0L 16V T.SPARK				09/97 → 10/00	76	AY490 (Fibre) [249]	DW711	EA5420
AR 32301	1970	4	83.00		110- 121/ 150- 165	BW710 (Fibre), 1.65mm (30-028420-00)	(21-28420-21/0) →05/98	(22-29064-00/0)
						AA5420 (MLS), 0.38mm (30-029064-00)	DW712 [101]	GW711 (20-28420-00/0) →05/98
						06/00 →	DW712 [101]	GW712 [101] (20-28420-01/0) 05/98 →06/00
							CA5420 [98]	(21-29064-20/0) 06/00 →











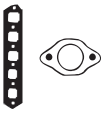

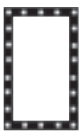

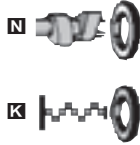



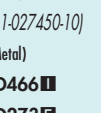
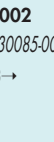
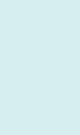

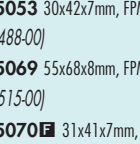



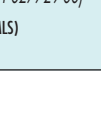
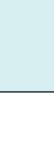

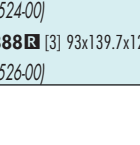







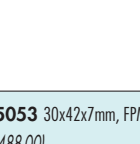



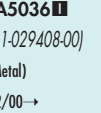
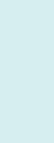
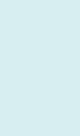

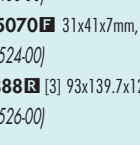



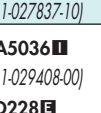
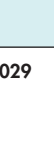

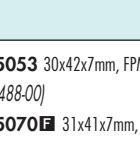



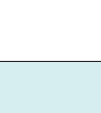



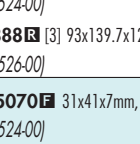



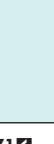
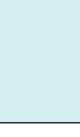

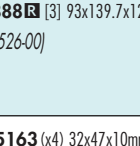



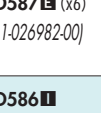

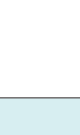

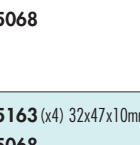

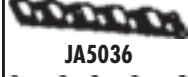

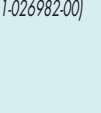
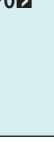
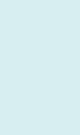

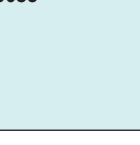







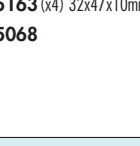













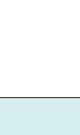



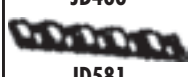











									
HBS132  (22-17015B) M10x1.25x254mm (x10)	JD271  (31-027450-10) (Metal) JD273  (31-027729-00) (MLS)	JM5002 (50-030085-00) 05/98 → HL700  (24-30088-00/0) →05/98	HR354 [94]			NA5053 30x42x7mm, FPM (50-319488-00) NA5069 55x68x8mm, FPM (50-319515-00) NA5070  31x41x7mm, FPM (50-319524-00) NF888  [3] 93x139.7x12mm, FPM (50-319526-00)		HL5030 [245]  HJ283 [39] 	 AA5570, AA5580  AY490  AY500  AY520, AY530, AY540  BW720, AA5420, BW710  JA5035
HBS132  (22-17015B) M10x1.25x254mm (x10)	JD271  (31-027450-10) (Metal) JD273  (31-027729-00) (MLS)	JM5002 (50-030085-00) 05/98 →				NA5053 30x42x7mm, FPM (50-319488-00) NA5069 55x68x8mm, FPM (50-319515-00) NA5070  31x41x7mm, FPM (50-319524-00) NF888  [3] 93x139.7x12mm, FPM (50-319526-00)		HL5030 [245] 	 JA5035  JD271  JD273  JD468  JD5376
HBS227  (22-17018B) M12x1.25x218mm (x10)	JD580  (Felt) →02/00 JA5035  (31-029407-00) JD468  (31-028377-00) (MLS)	JP063		HR363 		NA5053 30x42x7mm, FPM (50-319488-00) NA5070  31x41x7mm, FPM (50-319524-00) NF888  [3] 93x139.7x12mm, FPM (50-319526-00)		HL5031 [245]  KA845 [13]	 JD271  JD273  JD468  JD5376
HBS227  (22-17018B) M12x1.25x218mm (x10)	JA5035  (31-029407-00) JD580  JD468  (31-028377-00) (MLS)	JM5028 (31-029635-00) →Eng.4081110 JM5204 (50-029935-00) Eng.4081112 →				NA5053 30x42x7mm, FPM (50-319488-00) NA5070  31x41x7mm, FPM (50-319524-00) NF888  [3] 93x139.7x12mm, FPM (50-319526-00)		HL5031 [245] 	 JD580  HL700  JM5002
HBS227  (22-17018B) M12x1.25x218mm (x10)	JA5035  (31-029407-00) (Metal) JD580  (Felt) JD468  (31-028377-00) (MLS)	JM5028 (31-029635-00) →Eng.4081110 JM5204 (50-029935-00) Eng.4081112 →		HR363 		NA5053 30x42x7mm, FPM (50-319488-00) NA5070  31x41x7mm, FPM (50-319524-00) NF888  [3] 93x139.7x12mm, FPM (50-319526-00)		HL5031 [245] 	 JM5002  JM5028  JM5204
HBS370  (22-17026B) M12x1.25x225mm (x10)	JD5376  (31-029969-00)	JM7055 (Steel Elastomer)		HR5095 					 JM5204  JP063
HBS370  (22-17026B) M12x1.25x225mm (x10) HBS371  (22-17027B) M12x1.25x255mm (x12)	JD5376  (31-029969-00)	JM7055 (Steel Elastomer)		HR5095 					
HBS132  (22-17015B) M10x1.25x254mm (x10)	JD271  (31-027450-10) (Metal) JD273  (31-027729-00) (MLS)	JM5002 (50-030085-00) 08/98 → HL700  (24-30088-00/0) →05/98	HR354 [94]			NA5053 30x42x7mm, FPM (50-319488-00) NA5069 55x68x8mm, FPM (50-319515-00) NA5070  31x41x7mm, FPM (50-319524-00) NF888  [3] 93x139.7x12mm, FPM (50-319526-00)		HL5030 [245]  KL476 [70]	



KW/PS

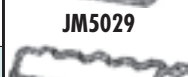

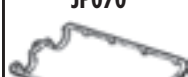
156 2.0L 16V T.SPARK				10/00 → 03/02		77	AD5950 (MLS), 0.45mm (30-029777-00) Eng.2832058 → AA5420 (MLS), 0.38mm (30-029064-00) 06/00 →	CA5420 ^[98] (21-29064-20/0) 06/00 →	EA5420 (22-29064-00/0)
AR 32310	1970	4	83.00			110/150			
156 2.0L JTS				03/02 → 05/06		78	AD5870 (MLS) (30-029769-00)		
937 A1.000	1970	4	83.00	Injection, DOHC		119- 122/ 162- 166			
156 2.4L JTD Diesel				09/97 → 10/00		79	AY550 (MLS), 1.60mm (30-029020-00) AY560 (MLS), 1.70mm, 1 Hole (30-029021-00) AY570 (MLS), 1.80mm, 2 Holes (30-029022-00)	CY520▲ ^[106] (21-29020-20/0)	FY520▲ ^[106] (20-29020-00/0)
AR 32501	2387	5	82.00	Direct Injection, SOHC		100/136			
156 2.4L JTD Diesel				10/00 → 05/06		80	AA5780 (MLS), 0.82mm (30-029266-00) AA5790 (MLS), 0.92mm (30-029282-00) AA5800 (MLS), 1.02mm (30-029283-00)	CA5780▲ (21-29266-20/0)	EA5780 (22-29266-00/0)
841 C.000	2387	5	82.00	Direct Injection		100- 110/ 136- 150			
839 A6.000	2387	5	82.00	Direct Injection, SOHC		103/140			
156 2.4L JTD Diesel				10/03 → 05/06		81	AD5910 (MLS), 0.82mm (30-029773-00) AD5920 (MLS), 0.92mm (30-029774-00) AD5930 (MLS), 1.02mm (30-029775-00)	CD5910 (21-29773-20/0)	ED5910 (22-29773-00/0)
841 G.000	2387	5	82.00	Direct Injection, DOHC		129/175			
156 2.5L V6 24V				09/97 → 10/00		82	AY630 (Fibre) (30-028113-00) AY620 (Fibre) (30-028114-10)	CY620	FY620
AR 32401	2492	6	88.00	DOHC, V6		140/190			
156 2.5L V6 24V				10/00 → 05/06		83	AY630 (Fibre) (30-028113-00) BT380 (Fibre), 1.65mm (30-027519-00) AY620 (Fibre) (30-028114-10)	CY620	FY620
AR 32405	2492	6	88.00	DOHC, V6		141/192			
156 3.2L GTA				03/02 → 05/06		84	BT380 (Fibre), 1.65mm (30-027519-00) AY640 (Fibre), 1.65mm (30-027518-10) 2051777--→	CY640 (21-27518-20/0)	FY640
932 A.000	3179	6	93.00	DOHC, V6		184/250			
159 1.9L JTS				09/05 →		85			
939 A6.000	1859	4	86.00	Injection, DOHC		118/160			
159 1.9L JTS				03/06 →		86			
159 1.9L JTDM 8V Diesel				09/05 →					
939 A6.000	1859	4	86.00	Injection, DOHC		118/160			
937A7.000/939 A7.000	1910	4	82.00	Direct Injection, SOHC		85/115			
159 1.9L JTDM 16V Diesel				09/05 →		87		CD5840▲ (21-29766-20/0)	EG7450 (22-30152-00/0)
939 A2.000	1910	4	82.00	Direct Injection, DOHC		110/150			

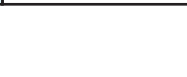
														AA5420
														AA5780
														AA5790
														AA5800
														AY550, AY560, AY570
														AY620, AY640
														AY630
														BT380
														JA5036
														JD228
														JD271
														JD273
														JD466
														JD581
														JD586
														JD587
														JM5002
														JM5029
														JP064
														JP070
														JP071











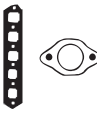



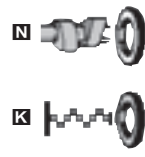

















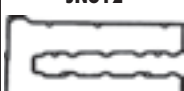





























ALFA ROMEO



KW/PS



159 1.9L JTDM 16V Diesel		03/06 →		88			CD5840▲ (21-29766-20/0)	EG7450 (22-30152-00/0)
939 A2.000	1910	4	82.00	Direct Injection, DOHC	110/150			
159 1.9L JTDM 16V Diesel		09/05 →		89		AG7410 (MLS) (30-030146-00)	CG7410 (21-30146-00/0)	EG7410 (22-30146-00/0)
939 A8.000	1910	4	82.00	Direct Injection, DOHC	100/136			
937 A8.000	1910	4	82.00	Direct Injection, DOHC	100- 100/ 136- 136	AG7420 (MLS) (30-030147-00)	06/04 →	
159 1.9L JTDM 16V Diesel		03/06 →		90			CD5840▲ (21-29766-20/0)	EG7450 (22-30152-00/0)
937 A8.000	1910	4	82.00	Direct Injection, DOHC	100- 100/ 136- 136		06/04 →	
159 1.9L JTDM 8V Diesel		09/05 →		91		AG7390 (MLS), 0.82mm (30-030144-00)	CG7390▲ (21-30144-00/0)	EG7390 (22-30144-00/0)
939 A1.000	1910	4	82.00	Direct Injection, SOHC	88/120	AG7400 (MLS), 0.92mm, 1 Hole (30-030145-00)		
						AG7440 (MLS) (30-030149-00)		
						Eng.159 2005 →		
159 2.2L JTS		09/05 →		92		AG9580 (MLS) (30-030344-00)		
939 A5.000	2198	4	86.00	Injection, DOHC	136/185			
159 2.4L JTDM Diesel		09/05 →		93		AG7410 (MLS) (30-030146-00)	CG7410 (21-30146-00/0)	EG7410 (22-30146-00/0)
939 A3.000	2387	5	82.00	Direct Injection, DOHC	147/200	06/04 →	06/04 →	06/04 →
						AG7420 (MLS) (30-030147-00)		
						06/04 →		
						AG7430 (MLS) (30-030148-00)		
						06/04 →		
164 2.0L T.S.		06/87 → 09/92		94		BT350 (Fibre) (30-026280-10)	DT350■ (21-26280-20/0)	GT350
AR 06416/AR 06420	1962	4	84.00	i.e.	107/146	AA5520 1.85mm (30-029640-00)		
164 2.0L T.S.		09/92 → 09/98		95		BW410 (Fibre) (30-027271-00)	DW410 (21-27271-20/0)	GW410 (20-27271-00/0)
AR 64103	1995	4	84.00	Injection	107/146			
164 2.0L Turbo		10/87 → 09/98		96		BT420 (Fibre) (30-025413-10)	DT420 (21-25413-21/0)	GT370
AR 06476	1995	4	84.00		128- 129/ 174- 175	01/88 → 12/89 → Eng.1033624	01/88 → 12/89 → Eng.1033624	01/90 → → Eng.1033625
						BT440 (Fibre) (30-026647-30)	DT370○ 01/90 →	
						01/90 → 12/89 Eng.1033625 →	Eng.1033625 →	
164 2.0L V6 Turbo		03/91 → 09/98		97		BW280 (Fibre) ■ (30-027266-00)	DW280 (21-27265-20/0)	GW280 (20-27265-00/0)
AR 64101/AR 64102	1997	6	80.00	V6	148/201	BW290 (Fibre) ■ (30-027265-00)		

								 BT350, AA5520  BT420, BT440  BW280  BW290  BW410  JC662  JD015  JD016  JD019  JD222  JD224  JD235  JE696  JN643  JN807  JN808  JN812  JN940  JJ413  JJ451
HBS370  (22-17026B) M12x1.25x225mm (x10) HBS465  (22-17029B) M12x1.50x220mm (x10)		JM7055 (Steel Elastomer)		HR5095 				
HBS371  (22-17027B) M12x1.25x255mm (x12) HBS465  (22-17029B) M12x1.50x220mm (x10)		JM7055 (Steel Elastomer)		HR5095 				
HBS370  (22-17026B) M12x1.25x225mm (x10)		JM7055 (Steel Elastomer)		HR5095 				
HBS227  (22-17018B) M12x1.25x218mm (x10) HBS465  (22-17029B) M12x1.50x220mm (x10)								
HBS416  (22-29025B) M11x1.50x163mm (x10)	KG5337  (50-350435-00) (MVQ) JD5868  (31-030346-00)							
HBS371  (22-17027B) M12x1.25x255mm (x12)								
	JD016  JD015  (x4) (31-027276-00)  JE696 (32-202195-10)	JN812 (31-027274-00)	JJ451	HR363 	 NA5066 (50-305717-00)  NA5068			
	JD235  (31-028775-00) JD015  (31-027276-00)	JN940 (50-028776-00)		HR363 	 NA5068			
HBS092  (22-17003B) M10x1.25x115mm (x10)	JC662  (31-026050-10) JD019  (31-027032-10)	JN643 (x2) (31-027225-00)	JJ413 (31-027315-00)	HR363 	 NA5187 30x52x7mm, ACM (50-319492-00)  NB742 30x43x8mm, ACM (50-319408-00)  NB732 74x90x10mm, FPM  NA5062 74x90x10mm, ACM	LB025 [13] KT465 [54] JS081 [11] KT639 [11] LV585 [45]		
	JD222  (31-027279-00) JD224  (x6) (31-028778-00)	JN808  (31-027281-00) JN807  (31-027280-00)			 NA5163 32x47x10mm, FPM			











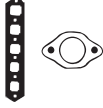

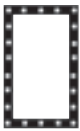



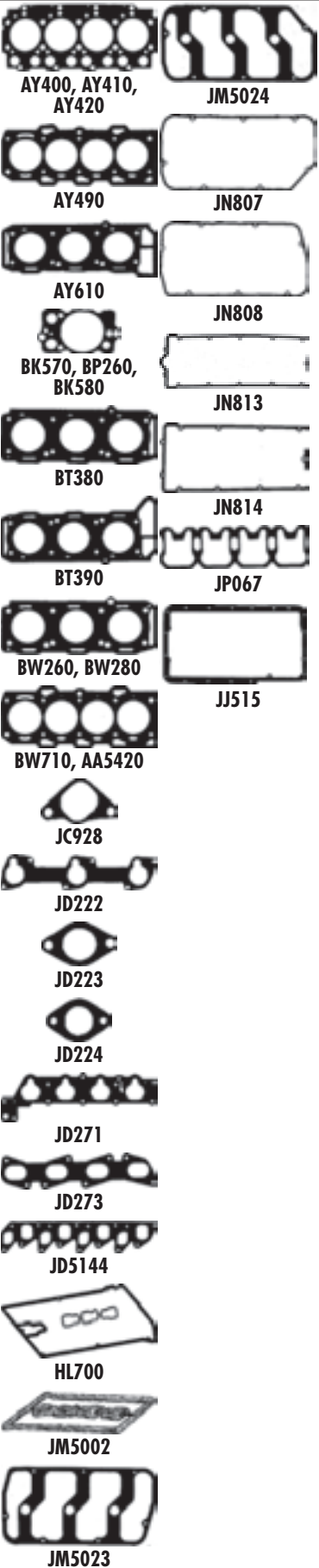







































ALFA ROMEO



KW/PS



164 2.5L TD Diesel		06/87 → 09/98		98		AY400 (MLS), 1.42mm, 0 Notches (30-028472-00)		DK570▲ [7] (21-25850-21/0) → 01/95		GK572▲ [8] (20-25850-01/0)	
VM 32 B	2499	4	92.00	Indirect Injection, SOHC	92/125						
VM 84 A	2500	4	92.00		85/115		BK570 (Fibre), 1.42mm, 0 Notches (x4) (30-025008-20)				
VM 08 B	2500	4	92.00	SOHC	92/125		AY410 (MLS), 1.52mm, 2 Notches (30-028473-00)				
							BP260 (Fibre), 1.52mm, 2 Notches (x4) (30-025013-20)				
							AY420 (MLS), 1.62mm, 1 Notch (30-028474-00)				
							BK580 (Fibre), 1.62mm, 1 Notch (x4) (30-025007-20)				
164 3.0L 24V		09/92 → 09/98		99		BT380 (Fibre), 1.65mm ☑ (30-027519-00)		DT380		GT380	
164 3.0L 24V Q4		02/94 → 09/98									
164 3.0L 24V QV		09/92 → 09/98					BT390 (Fibre) ☑ (30-027518-00)				
AR 64304/AR 64307/ AR 64308/AR 66301/ AR 66302	2959	6	93.00	i.e., V6	120- 171/ 163- 233						
164 3.0L i.e. QV		09/90 → 09/92		100		BW260 (Fibre) ☑ (30-025873-20)		DW260 (21-25873-20/0)		GW260	
164 3.0L V6		06/87 → 09/92									
AR 06410/AR 06412	2959	6	93.00	V6	147/200						
AR 06430	2959	6	93.00	Injection, DOHC, V6	147/200						
AR 64301	2959	6	93.00	V6	147/200						
164 3.0L V6		09/92 → 09/98		101		BW260 (Fibre) ☑ (30-025873-20)		DW261 (21-25873-23/0)		GW261 [8]	
AR 64305/AR 66303	2959	6	93.00	V6	132/180						
166 2.0L T.Spark		09/98 → 10/00		102		AY490 (Fibre) [249]		DW712 [101] (21-28420-22/0) 05/98 → 06/00		EA5420 (22-29064-00/0) GW712 [101] (20-28420-01/0) 05/98 → 06/00	
AR 34103	1970	4	83.00		110- 121/ 150- 165		BW710 (Fibre), 1.65mm (30-028420-00)				
							AA5420 (MLS), 0.38mm (30-029064-00)		CA5420 [98] (21-29064-20/0)		
							06/00 →		06/00 →		
166 2.0L T.Spark		10/00 →		103		AD5950 (MLS), 0.45mm (30-029777-00)		CA5420 [98] (21-29064-20/0)		EA5420 (22-29064-00/0)	
AR 36301	1970	4	83.00		110/150		AA5420 (MLS), 0.38mm (30-029064-00)		06/00 →		
							06/00 →				
166 2.0L V6		09/98 →		104		BW280 (Fibre) ☑ (30-027266-00)		CY610 [108] → Eng.004108		FY610 (20-27266-00/0)	
AR 34102	1997	6	80.00	V6	151/206		AY610 (Fibre) ☑ (30-029467-00)		CY611 Eng.004109 →		→ Eng.004108 FY611 Eng.004109 →

	 						
HBS105  (22-56001B) M14x2.0x137mm (x10) M12x1.75x80mm (x4) M12x1.75x116mm (x4) →12/92 HBS108  (22-56003B) M14x2.0x137mm (x10) M12x1.75x115mm (x4) M12x1.75x79.5mm (x4) 01/92→	JC928  (x4) (31-025852-10) JD5144 (31-028425-00)	JP067 (31-025850-10)					
		JN813  (31-028588-00) JN814  (31-028589-00)	KV086	HR800 	 NA5163 (x4) 32x47x10mm, FPM  NA5068		
	JD222  (x2) (31-027279-00) JD223  (x6) (31-027287-00)	JN808  (31-027281-00) JN807  (31-027280-00)	JJ515 KV086		 NA5163 (x2) 32x47x10mm, FPM  NA5068		
	JD222  (x2) (31-027279-00) JD223  (x6) (31-027287-00)	JM5023  JM5024  Eng.4081111→		HR815 	 NJ951 (x2) 32x50x8mm, FPM  NA5068		
HBS132  (22-17015B) M10x1.25x254mm (x10)	JD271  (31-027450-10) (Metal) JD273  (31-027729-00) (MLS)	JM5002 (50-030085-00) 05/98→ HL700  (24-30088-00/0) →05/98	HR354 [94]		 NA5053 30x42x7mm, FPM (50-319488-00)  NA5069 55x68x8mm, FPM (50-319515-00)  NA5070  31x41x7mm, FPM (50-319524-00)  NF888  [3] 93x139.7x12mm, FPM (50-319526-00)	HL5030 [245]  KL476 [70]	
HBS132  (22-17015B) M10x1.25x254mm (x10)		JM5002 (50-030085-00) 05/98→			 NA5053 30x42x7mm, FPM (50-319488-00)  NA5069 55x68x8mm, FPM (50-319515-00)  NA5070  31x41x7mm, FPM (50-319524-00)  NF888  [3] 93x139.7x12mm, FPM (50-319526-00)	HL5030 [245] 	
	JD222  (x2) (31-027279-00) JD224  (x6) (31-028778-00)	JM5023  JN808  (31-027281-00) →Eng.004108 JN807  (31-027280-00) →Eng.004108 JM5024  Eng.4081111→		HR815 	 NJ951  32x50x8mm, FPM	KA738 [13]	











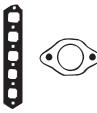





























































ALFA ROMEO



KW/PS



166 2.4L JTD Diesel		09/98 → 10/00			105	AY550 (MLS), 1.60mm (30-029020-00) AY560 (MLS), 1.70mm, 1 Hole (30-029021-00) AY570 (MLS), 1.80mm, 2 Holes (30-029022-00)	CY520▲ [106] (21-29020-20/0)	FY520▲ [106] (20-29020-00/0)
AR 34202	2387	5	82.00	Direct Injection, SOHC	100/136			
166 2.4L JTD Diesel		10/00 →			106	AA5780 (MLS), 0.82mm (30-029266-00) AA5790 (MLS), 0.92mm (30-029282-00) AA5800 (MLS), 1.02mm (30-029283-00)	CA5780▲ (21-29266-20/0)	EA5780 (22-29266-00/0)
839 A6.000	2387	5	82.00	Direct Injection, SOHC	103/140			
166 2.4L JTD Diesel		04/02 →			107	AA5780 (MLS), 0.82mm (30-029266-00) AA5790 (MLS), 0.92mm (30-029282-00) AA5800 (MLS), 1.02mm (30-029283-00)	CA5780▲ (21-29266-20/0)	EA5780 (22-29266-00/0)
841 C.000	2387	5	82.00	Direct Injection	100- 110/ 136- 150			
166 2.4L JTD Diesel		10/03 →			108	AD5910 (MLS), 0.82mm (30-029773-00) AD5920 (MLS), 0.92mm (30-029774-00) AD5930 (MLS), 1.02mm (30-029775-00)	CD5910 (21-29773-20/0)	ED5910 (22-29773-00/0)
841 G.000/841 H.000	2387	5	82.00	Direct Injection, DOHC	129/175			
166 2.5L V6 24V		09/98 → 10/00			109	AY630 (Fibre) ☒ (30-028113-00) AY620 (Fibre) ☒ (30-028114-10)	CY620	FY620
AR 34201	2492	6	88.00	DOHC, V6	140/190			
166 2.5L V6 24V		10/00 →			110	BT380 (Fibre), 1.65mm ☒ (30-027519-00) AY640 (Fibre), 1.65mm ☒ (30-027518-10)	CY620	FY620
AR 36201	2492	6	88.00	DOHC, V6	138/188			
166 3.0L V6 24V		09/98 → 10/00			111	BT380 (Fibre), 1.65mm ☒ (30-027519-00) AY640 (Fibre), 1.65mm ☒ (30-027518-10)	CY640 (21-27518-20/0)	FY640
AR 34301/AR 36101	2959	6	93.00	V6	162/220			
166 3.2L V6 24V		10/03 →			112	BT380 (Fibre), 1.65mm ☒ (30-027519-00) AY640 (Fibre), 1.65mm ☒ (30-027518-10)	CY640 (21-27518-20/0)	
936 A.000	3179	6	93.00	DOHC, V6	176/240			
1750-2000 2000		10/71 → 12/83			113	AN300 (Fibre) (30-024565-10)	CN301 [12] CN306 [12] (21-24565-22/0) DC373▲■	FN308 GH857▲ [12]
AR 10520	1962	4	84.00	SOHC	94/128			
Alfasud 1.2L		01/78 → 12/81			114	AA5540 (Fibre) (x2) (30-030087-00) AN350 (Fibre) (x2) (30-026481-00)	CN353 (21-26481-20/0)	FN353 (20-26481-00/0)
AR 30102	1186	4	80.00		50/68			

							
HBS257  [22-56010B] M12x1.25x218mm (x12)	JD581  →02/00 JA5036  (31-029408-00) (Metal) 02/00 → JD228  (31-027837-10)	JP064		HR363 	 NA5053 30x42x7mm, FPM (50-319488-00)  NA5070  31x41x7mm, FPM (50-319524-00)  NF888  [3] 93x139.7x12mm, FPM (50-319526-00)	HL5031 [245]  KA845 [13] JR5001 [11]	AA5540, AN350 AA5780 AA5790 AA5800 AN300 AY550, AY560, AY570 AY620, AY640 AY630 BT380 JA5036 JA829 JA840 JA898 JA899 JC497 JC507 JD228 JD581 JD586
HBS257  [22-56010B] M12x1.25x218mm (x12)	JA5036  (31-029408-00) (Metal) JD228  (31-027837-10)	JM5029		HR363 	 NA5053 30x42x7mm, FPM (50-319488-00)  NA5070  31x41x7mm, FPM (50-319524-00)  NF888  [3] 93x139.7x12mm, FPM (50-319526-00)	KA845 [13]	JE587 JE696 JM5029 JM669 JN588 JP004
HBS257  [22-56010B] M12x1.25x218mm (x12)	JA5036  (31-029408-00) JD228  (31-027837-10)	JM5029		HR363 	 NA5053 30x42x7mm, FPM (50-319488-00)  NA5070  31x41x7mm, FPM (50-319524-00)  NF888  [3] 93x139.7x12mm, FPM (50-319526-00)	HL5031 [245]  KL477 [70] KA845 [13] JR5001 [11]	KL477 JP064 JP070
HBS371  [22-17027B] M12x1.25x255mm (x12)							JP071 KV102
	JD586  (x2) JD587  (x6) (31-026982-00)	JP071  JP070 		HR800 	 NA5163 (x4) 32x47x10mm, FPM  NA5068		JA898 JA899
	JD586  (x2) JD587  (x6) (31-026982-00)	JP071  JP070 		HR800 	 NA5163 (x4) 32x47x10mm, FPM  NA5068		JA898 JA899
	JD586  (x2) JD587  (x6) (31-026982-00)	JP071  JP070 		HR800 	 NA5163 (x4) 32x47x10mm, FPM  NA5068	KA738 [13]	JA898 JA899 JJ452
					 NA5163 (x4) 32x47x10mm, FPM  NA5068		JA898 JA899 JJ452
JA840  01/76 → 12/82 JC497  (31-026240-10) 01/83 → 12/84 JA829  (x4) (31-022278-00)  JE696 (32-202195-10)		JP004 (31-022026-20) KV102	JJ452 (MVQ) KV086			KD383 [91] KV004 [91]	JA898 JA899 JC497 JC507 JD228 JD581
	JA898  (x2) JC507  (x2) JA899  (x4) (31-026340-10)	JM669 (31-023086-00) JN588 (31-025164-10)	JH565		 NA5064 35x58x10mm, ACM (50-306562-50)  NA5063  40x56x10mm, ACM  NA5065  62x80x12mm, ACM		JA898 JA899 JC497 JC507 JD228 JD581







ALFA ROMEO

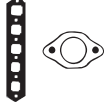

KW/PS

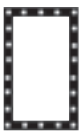

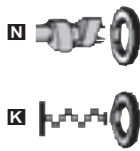
Alfasud 1.3L 03/80 → 12/81 115						AA5540 (Fibre) (x2) (30-030087-00)	CN353 (21-26481-20/0)	FN353 (20-26481-00/0)
Alfasud 1.3L SC/ti Super 09/77 → 09/84								
Alfasud 1.3L Super 01/79 → 09/84								
Alfasud 1.3L ti 03/80 → 12/84								
AR 30160	1287	4	80.00		50/68	AN350 (Fibre) (x2) (30-026481-00)		
AR 30164	1351	4	80.00	Carburettor	55/75			
AR 30168	1351	4	80.00	Carburettor	63/85			
Alfasud 1.3L 09/76 → 12/81 116						BE620 (Fibre) (x2) (30-024362-10)	DE622 (21-24362-21/0)	GE622
Alfasud 1.3L ti 09/77 → 09/84								
AR 30184	1490	4	84.00	SOHC	77/105			
Alfasud 1.4L 05/78 → 12/89 117						AA5540 (Fibre) (x2) (30-030087-00)	CN353 (21-26481-20/0)	FN353 (20-26481-00/0)
AR 30164	1351	4	80.00	Carburettor	55/75			
AR 30168	1351	4	80.00	Carburettor	63/85			
Alfasud 1.5L 05/78 → 12/87 118						BE620 (Fibre) (x2) (30-024362-10)	DE622 (21-24362-21/0)	GE622
Alfasud 1.5L ti 01/79 → 12/84								
Alfasud 1.5L ti Sprint 01/83 → 12/84								
AR 30124/ AR 30128/AR 30146	1490	4	84.00	SOHC	77/105			
Alfetta 1.6L 01/75 → 12/84 119						AN370 (Steel) (30-024142-40)	DC372 ■ (21-24833-20/0)	FF24R ▲ [12] GC374 GH857 ▲ [12]
Alfetta GT 1.6L 01/76 → 09/82								
AR 01600	1567	4	78.00	SOHC	79-80/ 108- 109			
Alfetta 1.8L 10/79 → 12/84 120						BH850 (Fibre) (30-021835-20)	DC373 ▲■	GH856 (20-21835-01/0) GH857 ▲ [12]
Alfetta GT 1.8L 01/74 → 12/76								
AR 01608 X	1779	4	80.00	SOHC	85/115			
AR 01608	1779	4	80.00	SOHC	89/121			
AR 01678	1779	4	80.00		90/122			
Alfetta 2.0L GT 06/77 → 12/84 121						AN300 (Fibre) (30-024565-10)	CN306 [12] (21-24565-22/0)	GH857 ▲ [12]
Alfetta 2.0L 03/77 → 12/84								
Alfetta GT 2.0L 07/78 → 01/86								
AR 01623	1962	4	84.00	SOHC	94/128			
AR 01655	1962	4	84.00		94/128			
AR 01713	1962	4	84.00	i.e.	94/128			
AR 10520	1962	4	84.00	SOHC	94/128			

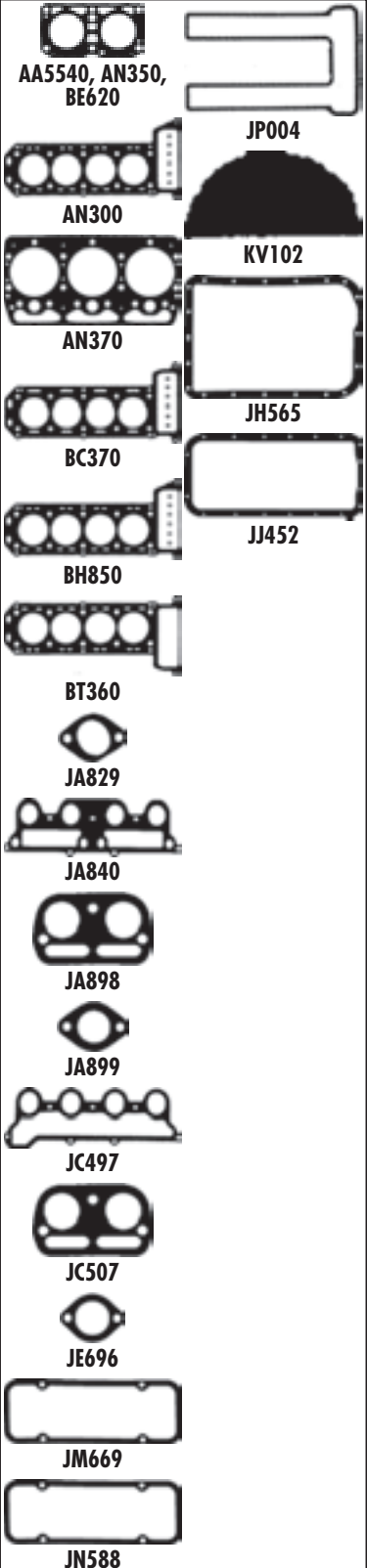
							
	JA898 (x2) JC507 (x2) JA899 (x4) <i>(31-026340-10)</i>	JM669 (x2) <i>(31-023086-00)</i> JN588 (x2) <i>(31-025164-10)</i>	JH565	HR602 24-30670-61/0	NA5064 35x58x10mm, ACM <i>(50-306562-50)</i> NA5063 40x56x10mm, ACM NA5065 62x80x12mm, ACM		AA5540, AN350, BE620 AN300 AN370 BC370 BH850 BT360 JA829 JA840 JA898 JA899 JC497 JC507 JE696 JM669 JN588 JP004 KV102 KV086
	JA898 (x2) JC507 (x2) JA899 (x4) <i>(31-026340-10)</i>	JM669 (x2) <i>(31-023086-00)</i> JN588 (x2) <i>(31-025164-10)</i>	JH565	HR602 24-30670-61/0	NA5064 35x58x10mm, ACM <i>(50-306562-50)</i> NA5063 40x56x10mm, ACM NA5065 62x80x12mm, ACM		AN300 AN370 BC370 BH850 BT360 JA829 JA840 JA898 JA899 JC497 JC507 JE696 JM669 JN588 JP004 KV102 KV086
	JA898 (x2) JC507 (x2) JA899 (x4) <i>(31-026340-10)</i>	JM669 (x2) <i>(31-023086-00)</i> JN588 (x2) <i>(31-025164-10)</i>	JH565	HR602 24-30670-61/0	NA5064 35x58x10mm, ACM <i>(50-306562-50)</i> NA5063 40x56x10mm, ACM NA5065 62x80x12mm, ACM		AN300 AN370 BC370 BH850 BT360 JA829 JA840 JA898 JA899 JC497 JC507 JE696 JM669 JN588 JP004 KV102 KV086
	JA898 (x2) JC507 (x2) JA899 (x4) <i>(31-026340-10)</i>	JM669 (x2) <i>(31-023086-00)</i> JN588 (x2) <i>(31-025164-10)</i>	JH565	HR602 24-30670-61/0	NA5064 35x58x10mm, ACM <i>(50-306562-50)</i> NA5063 40x56x10mm, ACM NA5065 62x80x12mm, ACM		AN300 AN370 BC370 BH850 BT360 JA829 JA840 JA898 JA899 JC497 JC507 JE696 JM669 JN588 JP004 KV102 KV086
	JA840 01/76 → 12/82 JC497 <i>(31-026240-10)</i> 01/83 → 12/84 JA829 (x4) <i>(31-022278-00)</i> JE696 <i>(32-202195-10)</i>	JP004 <i>(31-022026-20)</i> KV102	JJ452 (MVQ) KV086			KA350 [13] KD383 [91] KV004 [91]	JA840 JA898 JA899 JC497 JC507 JE696 JM669 JN588 JP004 KV102 KV086
	JA840 01/76 → 12/82 JC497 <i>(31-026240-10)</i> 01/83 → 12/84 JA829 (x4) <i>(31-022278-00)</i> JE696 <i>(32-202195-10)</i>	JP004 <i>(31-022026-20)</i> KV102	JJ452 (MVQ) KV086			KA350 [13]	JA840 JA898 JA899 JC497 JC507 JE696 JM669 JN588 JP004 KV102 KV086
	JA840 01/76 → 12/82 JC497 <i>(31-026240-10)</i> 01/83 → 12/84 JA829 (x4) <i>(31-022278-00)</i>	JP004 <i>(31-022026-20)</i> KV102	JJ452 (MVQ) KV086				JA840 JA898 JA899 JC497 JC507 JE696 JM669 JN588 JP004 KV102 KV086



KW/PS



Alfa Romeo Model		Year Range	Code	Stroke	Valves	Configuration	Power (KW/PS)	Parts	Accessories
Alfa Romeo 2.0L TD Diesel		10/79 → 03/83	122						
VM 4HT/2	1995	4	88.00	OHV		60/73/ 82/99	AY400 (MLS), 1.42mm, 0 Notches (30-028472-00) BK570 (Fibre), 1.42mm, 0 Notches (x4) (30-025008-20) AY410 (MLS), 1.52mm, 2 Notches (30-028473-00) BP260 (Fibre), 1.52mm, 2 Notches (x4) (30-025013-20) AY420 (MLS), 1.62mm, 1 Notch (30-028474-00) BK580 (Fibre), 1.62mm, 1 Notch (x4) (30-025007-20)	DK570 ▲ [7] (21-25850-21/0)	GK570 ▲ [36] (20-25850-02/0)
Alfa Romeo 2.4L TD Diesel		04/83 → 12/84	123						
VM 4HT 2.4	2393	4	92.00	OHV		81/110	AY400 (MLS), 1.42mm, 0 Notches (30-028472-00) BK570 (Fibre), 1.42mm, 0 Notches (x4) (30-025008-20) AY410 (MLS), 1.52mm, 2 Notches (30-028473-00) BP260 (Fibre), 1.52mm, 2 Notches (x4) (30-025013-20) AY420 (MLS), 1.62mm, 1 Notch (30-028474-00) BK580 (Fibre), 1.62mm, 1 Notch (x4) (30-025007-20)	CN306 [12] (21-24565-22/0) DC373 ▲■	GH857 ▲ [12]
Alfa Romeo 6 1.9L D Diesel		04/85 → 12/89	124						
160 D100	1929	4	82.60			66/68/ 90/92	BV680 (Fibre), 1.67mm, 0 Notches (30-026296-10) BV690 (Fibre), 1.75mm, 1 Notch BV700 (Fibre), 1.85mm, 2 Notches (30-027859-00)	DV680 ▲ (21-25142-26/0)	
Alfa Romeo 6 Van 2.4L D Diesel		04/85 → 02/86	125						
8144.61.200	2445	4	93.00			53/72	BE580 (Fibre), 1.35mm (30-024116-10)	DE588 ▲ [109] (21-26037-23/0)	FY291 ▲ [110] (20-27426-00/0)
Alfa Romeo 6 Van 2.4L TD Diesel		09/86 → 12/89	126						
8144.21.220	2445	4	93.00			68/92	BR070 (Fibre), 1.20mm (30-025645-10)	DS381 ▲ [111] (21-27141-20/0)	FB5100 ▲ [12] (20-27140-00/0)
Alfa Romeo 6 Van 2.5L D Diesel		03/86 → 12/89	127						
8144.67.220	2500	4	93.00	Indirect Injection		55/75	AY290 (Fibre), 1.60mm [112] (30-027426-00) AY300 (Fibre), 1.70mm [112] (30-026654-20) AY310 (Fibre), 1.80mm [112] (30-026655-20)	DE588 ▲ [109] (21-26037-23/0)	FY291 ▲ [110] (20-27426-00/0)
Alfa Romeo 8 2.4L D Diesel		04/78 → 08/86	128						
8140.61.200	2445	4	93.00			53/72	BE580 (Fibre), 1.35mm (30-024116-10)	DE588 ▲ [109] (21-26037-23/0)	FY291 ▲ [110] (20-27426-00/0)

HBS105 (22-56001B) M14x2.0x137mm (x10) M12x1.75x80mm (x4) M12x1.75x116mm (x4)	JC928 (31-025852-10) JD5144 (31-028425-00) JD025 (x4) (31-025849-10) JF123 (31-027523-00)	JN581 (x4) JP067 (31-025850-10)				LA246 ^[37]	
HBS105 (22-56001B) M14x2.0x137mm (x10) M12x1.75x80mm (x4) M12x1.75x116mm (x4)	JD5144 (x4) (31-028425-00)	JN581 JP067 (31-025850-10) KV086					
HBS095 (22-17007B) M12x1.25x133mm (x10)							
HBS011 (22-51004B) M12x1.25x160mm (x10) M12x1.25x119mm (x12)	JC054 (31-024274-10) JC055 (31-025031-10)	JN594 [71] (50-026037-00)	JJ100 JJ519 (31-025623-00)	HR602 24-30670-61/0	NP067 50x70x10mm, FPM (50-307111-70) NP068 55x70x8mm, FPM (50-303186-00) NF833 (50-305860-50) NA5055 70x90x10mm, FPM	JR580 [11]	
HBS011 (22-51004B) M12x1.25x160mm (x10) M12x1.25x119mm (x12)	JC054 (x4) (31-024274-10) JC706 JC707 (31-026039-00)	JN594 [71] (50-026037-00)	JJ100	HR602 24-30670-61/0	NP067 50x70x10mm, FPM (50-307111-70) NP068 55x70x8mm, FPM (50-303186-00) NF833 (50-305860-50) NA5055 70x90x10mm, FPM		
HBS011 (22-51004B) M12x1.25x160mm (x10) M12x1.25x119mm (x12)	JC054 (x4) (31-024274-10) JC055 (x4) (31-025031-10)	JN462 (50-024272-00) JN594 [71] (50-026037-00) Eng.574799→	JJ100 JJ519 (31-025623-00)	HR602 24-30670-61/0	NP067 50x70x10mm, FPM (50-307111-70) NP068 55x70x8mm, FPM (50-303186-00) NA5055 70x90x10mm, FPM		
HBS011 (22-51004B) M12x1.25x160mm (x10) M12x1.25x119mm (x12)	JC054 (31-024274-10) JC055 (31-025031-10)	JN594 [71] (50-026037-00)	JJ100 JJ519 (31-025623-00)	HR602 (x8) 24-30670-61/0	NP067 50x70x10mm, FPM (50-307111-70) NP068 55x70x8mm, FPM (50-303186-00) NF833 (50-305860-50) NA5055 70x90x10mm, FPM	JR580 [11]	

ALFA ROMEO









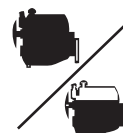



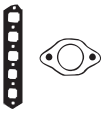

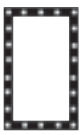

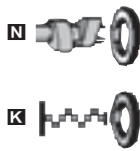































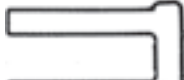







cc



KW/PS



AR 8 2.4L TD Diesel						04/85 → 12/88	129	BR070 (Fibre), 1.20mm (30-025645-10)	DS381▲ [111] (21-27141-20/0)	FB5100▲ [12] (20-27140-00/0)
AR 8 Van 2.4L TD Diesel						04/85 → 12/89				
8140.21.200 D.I.	2445	4	93.00	Indirect Injection, SOHC	68/92					
AR 8 Van 2.4L D Diesel						04/78 → 08/86	130	BE580 (Fibre), 1.35mm (30-024116-10)	DE588▲ [109] (21-26037-23/0)	FY291▲ [110] (20-27426-00/0)
8140.61.200	2445	4	93.00		53/72					
AR 8 2.5L D Diesel						09/86 → 12/89	131	AY290 (Fibre), 1.60mm [112] (30-027426-00)	DE588▲ [109] (21-26037-23/0)	FY291▲ [110] (20-27426-00/0)
AR 8 Van 2.5L D Diesel						09/86 → 12/89				
8144.67.220	2500	4	93.00	Indirect Injection	55/75		AY300 (Fibre), 1.70mm [112] (30-026654-20)			
							AY310 (Fibre), 1.80mm [112] (30-026655-20)			
Arna 1.3L TI						03/83 → 12/86	132	AN350 (Fibre) (30-026481-00)	CN353 (21-26481-20/0)	FN355 (20-26481-01/0)
AR 30168	1351	4	80.00	Carburettor	63/85					
AR 31010	1351	4	80.00		63/86					
Arna 1.5L						01/85 → 12/86	133	BE620 (Fibre) (x2) (30-024362-10)	DE622 (21-24362-21/0)	
AR 30182	1490	4	84.00	SOHC	77/105					
Brera 2.2L JTS						01/06 →	134	AG9580 (MLS) (30-030344-00)		
939 A5.000	2198	4	86.00	Injection, DOHC	136/185					
Giulietta 1.8L						04/79 → 04/85	135	BH850 (Fibre) (30-021835-20)	DC373▲■	GH856 (20-21835-01/0) GH857▲ [12]
AR 01678	1779	4	80.00		90/122					
Giulietta 1.8L Turbo						01/84 → 12/85	136	BT360 (Fibre) (30-026016-10)	DT360 (21-26016-20/0)	
AR 01354	1779	4	80.00		155/211					
Giulietta 2.0L						06/80 → 04/85	137	AN300 (Fibre) (30-024565-10)	CN306 [12] (21-24565-22/0) DC373▲■	GH857▲ [12]
AR 01655/AR 11671	1962	4	84.00		94/128					

								
HBS011  (22-51004B) M12x1.25x160mm (x10) M12x1.25x119mm (x12)	JC054  (x4) (31-024274-10) JC706  JC707  (31-026039-00)	JN594 [71] (50-026037-00)	JJ100	HR602  24-30670-61/0	NP067 50x70x10mm, FPM (50-307111-70) NP068 55x70x8mm, FPM (50-303186-00) NF833  (50-305860-50) NA5055  70x90x10mm, FPM			 AN300  AN350, BE620  AY290, AY300, AY310  BE580  BH850  BR070  BT360  JA829  JA840  JC054  JC055  JC497  JC706  JC707  JE696  JN462
HBS011  (22-51004B) M12x1.25x160mm (x10) M12x1.25x119mm (x12)	JC054  (31-024274-10) JC055  (31-025031-10)	JN594 [71] (50-026037-00)	JJ100 JJ519 (31-025623-00)	HR602  (x8) 24-30670-61/0 HR782 	NP067 50x70x10mm, FPM (50-307111-70) NP068 55x70x8mm, FPM (50-303186-00) NF833  (50-305860-50) NA5055  70x90x10mm, FPM	JR580 [11]		 JP004  KV102  JJ100  JJ452  JJ519
HBS011  (22-51004B) M12x1.25x160mm (x10) M12x1.25x119mm (x12)	JC054  (x4) (31-024274-10) JC055  (x4) (31-025031-10)	JN462 (50-024272-00) JN594 [71] (50-026037-00) Eng.574799 →	JJ100 JJ519 (31-025623-00)	HR602  24-30670-61/0	NP067 50x70x10mm, FPM (50-307111-70) NP068 55x70x8mm, FPM (50-303186-00) NA5055  70x90x10mm, FPM			
	KG5337  (50-350435-00) (MVQ) JD5868  (31-030346-00)							
	JA840  01/76 → 12/82 JC497  (31-026240-10) 01/83 → 12/84 JA829  (x4) (31-022278-00)  JE696 (32-202195-10)	JP004 (31-022026-20) KV102	JJ452 (MVQ) KV086			KA350 [13]		
	JA840  01/76 → 12/82 JC497  (31-026240-10) 01/83 → 12/84 JA829  (x4) (31-022278-00)	JP004 (31-022026-20) KV102	JJ452 (MVQ) KV086					











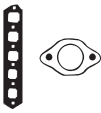

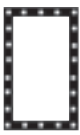

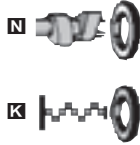







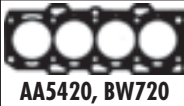







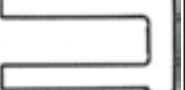



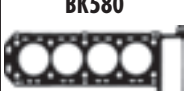

















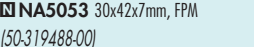
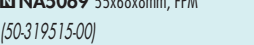
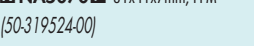





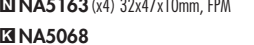

ALFA ROMEO



KW/PS

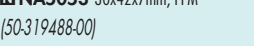
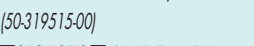
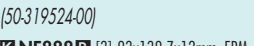

Giulietta 2.0L TD Diesel		01/83 → 12/85		138				
VM 4 HT	1995	4	88.00	Indirect Injection, OHV	61/82	AY400 (MLS), 1.42mm, 0 Notches (30-028472-00) BK570 (Fibre), 1.42mm, 0 Notches (x4) (30-025008-20) AY410 (MLS), 1.52mm, 2 Notches (30-028473-00) BP260 (Fibre), 1.52mm, 2 Notches (x4) (30-025013-20) AY420 (MLS), 1.62mm, 1 Notch (30-028474-00) BK580 (Fibre), 1.62mm, 1 Notch (x4) (30-025007-20)	DK570 ▲ [7] (21-25850-21/0)	GK570 ▲ [36] (20-25850-02/0)
GT Coupe 1300 Junior		01/66 → 12/77		139				
AR 00530	1290	4	74.00	Injection	64-65/ 87-89	AF240 (Fibre) (30-022269-30)	CF24N ▲ [12]	FF24R ▲ [12]
GT Coupe 1600		01/66 → 12/77		140				
AR 00536	1567	4	78.00	DOHC	80/109	AF370 (Fibre) AN370 (Steel) (30-024142-40) BT360 (Fibre) (30-026016-10)	CF24N ▲ [12]	FF24R ▲ [12]
GT Coupe 1.8L TS		11/03 →		141				
AR 32205	1747	4	82.00		103/140	AA5420 (MLS), 0.38mm (30-029064-00)	CA5420 [98] (21-29064-20/0)	EA5420 (22-29064-00/0)
GT Coupe 1.9L JTD Diesel		11/03 →		142				
937 A5.000	1910	4	82.00	Direct Injection, DOHC	110/150	AD5840 (MLS), 0.82mm, 0 Holes (30-029766-00) AD5850 (MLS), 0.92mm, 1 Hole (30-029767-00) AD5860 (MLS), 1.02mm, 2 Holes (30-029768-00)	CD5840 ▲ (21-29766-20/0)	EE5181 (22-29832-01/0)
GT Coupe 2.0L JTS		11/03 →		143				
937 A1.000	1970	4	83.00	Injection, DOHC	119- 122/ 162- 166	AD5870 (MLS) (30-029769-00)		
932 A2.000	1970	4	83.00	Injection, DOHC	121/165			
GT Coupe 3.2L GTA		11/03 →		144				
936 A.000	3179	6	93.00	DOHC, V6	176/240	BT380 (Fibre), 1.65mm (30-027519-00) AY640 (Fibre), 1.65mm (30-027518-10)	CY640 (21-27518-20/0)	FY640
GTV Coupe 1.8L 16V		05/98 →		145				
AR 32201	1747	4	82.00		106/144	AY500 (Fibre) [249] BW720 (Fibre), 1.65mm (30-028382-00)	DW721 [95] (21-28382-21/0)	GW722 [96] (20-28382-01/0) 05/98 → 06/00

								
HBS105  [22-56001B] M14x2.0x137mm (x10) M12x1.75x80mm (x4) M12x1.75x116mm (x4)	JC928  [31-025852-10] JD5144 [31-028425-00] JD025  (x4) [31-025849-10]  JF123 [31-027523-00]	JN581 (x4) JP067 [31-025850-10]					LA246  [37] 	 AA5420, BW720  HL700  AF240, AF370  JM5002  AN370  JN581  AY400, AY410, AY420  JP004  AY500  JP067  AY640  BK570, BP260, BK580  KV102  BT360  JJ452  BT380  JA829  JA840  JC928  JD025  JD271  JD273  JD5144  JD5376  JF123
	JA840  01/76 → 01/82 JA829  (x4) [31-022278-00]	JP004 [31-022026-20] KV102	JJ452 (MVQ) KV086				KA350 [13] KD383 [91] KV004 [91] JH526 [11]	
	JA840  JA829  [31-022278-00]	JP004 [31-022026-20] KV102	JJ452 (MVQ) KV086					
HBS132  [22-17015B] M10x1.25x254mm (x10)	JD271  [31-027450-10] (Metal) JD273  [31-027729-00] (MLS)	JM5002 [50-030085-00]	HR354 [94]		 NA5053 30x42x7mm, FPM [50-319488-00]  NA5069 55x68x8mm, FPM [50-319515-00]  NA5070 31x41x7mm, FPM [50-319524-00]  NF888 [3] 93x139.7x12mm, FPM [50-319526-00]	HL5030 [245] 		
HBS370  [22-17026B] M12x1.25x225mm (x10)	JD5376  [31-029969-00]	JM7055 (Steel Elastomer)		HR5095 				
HBS132  [22-17015B] M10x1.25x254mm (x10)								
				HR800 	 NA5163 (x4) 32x47x10mm, FPM  NA5068			
HBS132  [22-17015B] M10x1.25x254mm (x10)	JD271  [31-027450-10] (Metal) JD273  [31-027729-00] (MLS)	JM5002 [50-030085-00] 05/98 → HL700  [24-30088-00/0] →05/98	HR354 [94]		 NA5053 30x42x7mm, FPM [50-319488-00]  NA5069 55x68x8mm, FPM [50-319515-00]  NA5070 31x41x7mm, FPM [50-319524-00]  NF888 [3] 93x139.7x12mm, FPM [50-319526-00]	HL5030 [245]  HJ283 [39] 		











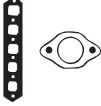

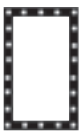

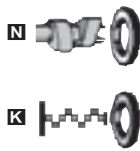





















ALFA ROMEO

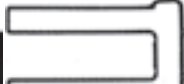

KW/PS



GTV Coupe 2.0L				07/78 → 01/86	146	AN300 (Fibre) (30-024565-10)	CN306 [12] (21-24565-22/0) DC373 ▲ ■	GH857 ▲ [12]
AR 01655	1962	4	84.00	DOHC	94/128 94/128			
AR 06212	1962	4	84.00					
GTV Coupe 2.0L JTS				04/03 →	147	AD5870 (MLS) (30-029769-00)		
937 A1.000	1970	4	83.00	Injection, DOHC	119- 122/ 162- 166			
GTV Coupe 2.0L T.SPARK 16V				06/95 →	148	AA5420 (MLS), 0.38mm (30-029064-00) AR32310 AD5950 (MLS), 0.45mm (30-029777-00) AR32310 BW710 (Fibre), 1.65mm (30-028420-00) AY490 (Fibre) [249] 06/00 →	CA5420 [98] (21-29064-20/0) AR32310 DW710 (21-28420-20/0)	EA5420 (22-29064-00/0) AR32310 GW713 (20-28420-02/0)
AR 16201/AR 32310	1970	4	83.00		110/150			
GTV Coupe 2.0L T.SPARK 16V				05/98 → 08/00	149	AY490 (Fibre) [249] BW710 (Fibre), 1.65mm (30-028420-00)	CA5420 [98] (21-29064-20/0) AR32310 DW711 (21-28420-21/0) → 05/98 DW712 [101] (21-28420-22/0) 05/98 → 06/00	GW711 (20-28420-00/0) → 05/98 GW712 [101] (20-28420-01/0) 05/98 → 06/00
AR 32301	1970	4	83.00		110- 121/ 150- 165			
GTV Coupe 2.0L V6 Turbo				06/95 →	150	BW280 (Fibre) ■ (30-027266-00) BW290 (Fibre) ■ (30-027265-00)	DW282 → Eng.7486 DW281 [108] (21-27266-20/0) Eng.7485 →	GW281 → Eng.7485 GW282 [115] Eng.7486 →
AR 16202	1997	6	80.00	V6	148/201			
GTV Coupe 3.0L V6 24V				10/96 → 10/00	151	BT380 (Fibre), 1.65mm ■ (30-027519-00) AY640 (Fibre), 1.65mm ■ (30-027518-10)	CY640 (21-27518-20/0)	FY640
AR 16105	2959	6	93.00	V6	160/218			
AR 16102	2959	6	93.00	V6	162/220			
Mito 1.4L TB				09/08 →	152			
199 A8.000	1368	4	72.00	DOHC	114/155			
Spider Convertible 1300				01/68 → 12/77	153	AF240 (Fibre) (30-022269-30)	CF24N ▲ [12]	FF24R ▲ [12]
AR 00530	1290	4	74.00	Injection	64-65/ 87-89			
Spider Convertible 1600				03/66 → 12/68	154	AN370 (Steel) (30-024142-40) AY500 (Fibre) [249] 109 BT360 (Fibre) (30-026016-10) BW720 (Fibre), 1.65mm (30-028382-00)	DW721 [95] (21-28382-21/0) → 05/98	FF24R ▲ [12] GW722 [96] (20-28382-01/0) 05/98 → 06/00
AR 00526	1567	4	78.00	SOHC	75-80/ 102- 109			
AR 01600	1567	4	78.00	SOHC	79-80/ 108- 109			
AR 00536	1567	4	78.00	DOHC	80/109			

										
		JA840 [113] 01/76→12/82 JC497 [114] (31-026240-10) 01/83→12/84 JA829 (x4) (31-022278-00)  JE696 (32-202195-10)	JP004 (31-022026-20) KV102	JJ452 (MVQ) KV086					 AA5420, BW710, BW720  AF240  AN300  AN370  AY490  AY500  AY640  BT360  BT380  BW280  BW290  JA829  JA840  JC497  JD271  JD272  JD273  JD586  JD587	 JE442  JE447  JE696  HL700  JM5002  JP004  JP070  JP071  KV102  JJ452
HBS132 [22-17015B] M10x1.25x254mm (x10)										
HBS132 [22-17015B] M10x1.25x254mm (x10)	JD271 [31-027450-10] (Metal) JD272 [31-028558-00]	HL700 [24-30088-00/0]				NA5053 30x42x7mm, FPM (50-319488-00) NA5069 55x68x8mm, FPM (50-319515-00) NA5070 31x41x7mm, FPM (50-319524-00) NF888 [3] 93x139.7x12mm, FPM (50-319526-00)	HL5030 [245] [KL476] [70]			
HBS132 [22-17015B] M10x1.25x254mm (x10)	JD271 [31-027450-10] (Metal) JD273 [31-027729-00] (MLS)	JM5002 [50-030085-00]	HR354 [94]			NA5053 30x42x7mm, FPM (50-319488-00) NA5069 55x68x8mm, FPM (50-319515-00) NA5070 31x41x7mm, FPM (50-319524-00) NF888 [3] 93x139.7x12mm, FPM (50-319526-00)	HL5030 [245] [KL476] [70]			
	JD586 (x2) JD587 (x6) (31-026982-00)	JP071 JP070		HR800		NA5163 (x4) 32x47x10mm, FPM NA5068	KA738 [13]			
HBS247 [22-17019B] M9x1.25x87mm (x10)										
	JA840 01/76→01/82 JA829 (x4) (31-022278-00)  JE442 (x2)  JE447	JP004 (31-022026-20) KV102	JJ452 (MVQ) KV086				KA350 [13] KD383 [91] KV004 [91] JH526 [11]			
	JD271 (x4) (31-027450-10) (Metal) JD273 (31-027729-00) (MLS)	JM5002 (50-030085-00) 05/98→ HL700 (24-30088-00/0) →05/98	HR354 [94]			NA5070 31x41x7mm, FPM (50-319524-00) NA5069 55x68x8mm, FPM (50-319515-00) NF888 [3] 93x139.7x12mm, FPM (50-319526-00)	HJ283 [39]			

ALFA ROMEO



KW/PS



Spider Convertible 1600				03/76 → 12/90	155	AN370 (Steel) (30-024142-40) BT360 (Fibre) (30-026016-10)	CF24N▲ [12]	
AR 00526	1567	4	78.00	SOHC	75-80/ 102- 109			
Spider Convertible 1600				01/90 → 12/93	156		DC372■ (21-24833-20/0)	
AR 01563	1570	4	78.10	SOHC	79/107			
Spider Convertible 1.8L 16V				05/98 → 04/05	157	AY500 (Fibre) [249] BW720 (Fibre), 1.65mm (30-028382-00)	DW721 [95] (21-28382-21/0) → 05/98 DW722 (21-28382-22/0) 05/98 → 06/00	GW721 GW724 GW722 [96] (20-28382-01/0) 05/98 → 06/00
AR 32201	1747	4	82.00		106/144			
Spider Convertible 2.0L JTS				04/03 → 04/05	158	AD5870 (MLS) (30-029769-00)		
937 A1.000	1970	4	83.00	Injection, DOHC	119- 122/ 162- 166			
Spider Convertible 2.0L T.SPARK 16V				06/95 → 04/05	159	AA5420 (MLS), 0.38mm (30-029064-00) AR32310 AD5950 (MLS), 0.45mm (30-029777-00) AR32310 BW710 (Fibre), 1.65mm (30-028420-00) AY490 (Fibre) [249] 06/00 →	CA5420 [98] (21-29064-20/0) AR32310 DW710 (21-28420-20/0)	EA5420 (22-29064-00/0) AR32310 GW713 (20-28420-02/0)
AR 16201/AR 32310	1970	4	83.00		110/150			
Spider Convertible 2.0L T.SPARK 16V				05/98 → 08/00	160	AY490 (Fibre) [249] BW710 (Fibre), 1.65mm (30-028420-00) AA5420 (MLS), 0.38mm (30-029064-00) 06/00 →	DW712 [101] (21-28420-22/0) 05/98 → 06/00 CA5420 [98] (21-29064-20/0) 06/00 →	EA5420 (22-29064-00/0) GW712 [101] (20-28420-01/0) 05/98 → 06/00
AR 32301	1970	4	83.00		110- 121/ 150- 165			
Spider Convertible 2.0L V6 Turbo				05/98 → 04/05	161	BW280 (Fibre) (30-027266-00) BW290 (Fibre) (30-027265-00)	DW282 → Eng.7486 DW281 [108] (21-27266-20/0) Eng.7485 →	GW281 → Eng.7485 GW282 [115] Eng.7486 →
AR 16202	1997	6	80.00	V6	148/201			
Spider Convertible 2000				08/86 → 12/90	162	AN300 (Fibre) (30-024565-10)	CN308 [12] (21-24565-23/0)	
AR 01544	1962	4	84.00	i.e., SOHC	94/128			
Spider Convertible 2000				01/90 → 12/93	163	BT350 (Fibre) (30-026280-10) AA5520 1.85mm (30-029640-00)	DT350■ (21-26280-20/0)	GT351
AR 01588	1962	4	84.00	i.e., SOHC	88/120			

						NA5070 31x41x7mm, FPM (50-319524-00) NA5069 55x68x8mm, FPM (50-319515-00) NF888 [3] 93x139.7x12mm, FPM (50-319526-00)					
HBS132 [22-17015B] M10x1.25x254mm (x10)	JD271 [31-027450-10] (Metal) JD273 [31-027729-00] (MLS)	JM5002 (50-030085-00) 05/98 → HL700 [24-30088-00/0] →05/98	HR354 [94]		NA5053 30x42x7mm, FPM (50-319488-00) NA5069 55x68x8mm, FPM (50-319515-00) NA5070 31x41x7mm, FPM (50-319524-00) NF888 [3] 93x139.7x12mm, FPM (50-319526-00)	HL5030 [245] [5] HL283 [39] [5]					
HBS132 [22-17015B] M10x1.25x254mm (x10)											
HBS132 [22-17015B] M10x1.25x254mm (x10) AR32310	JD271 [31-027450-10] (Metal) JD272 [31-028558-00]	JM5002 (50-030085-00) AR32310 HL700 [24-30088-00/0]			NA5053 30x42x7mm, FPM (50-319488-00) NA5069 55x68x8mm, FPM (50-319515-00) NA5070 31x41x7mm, FPM (50-319524-00) NF888 [3] 93x139.7x12mm, FPM (50-319526-00)	HL5030 [245] [5] KL476 [70]					
HBS132 [22-17015B] M10x1.25x254mm (x10)	JD271 [31-027450-10] (Metal) JD273 [31-027729-00] (MLS)	JM5002 (50-030085-00)	HR354 [94]		NA5053 30x42x7mm, FPM (50-319488-00) NA5069 55x68x8mm, FPM (50-319515-00) NA5070 31x41x7mm, FPM (50-319524-00) NF888 [3] 93x139.7x12mm, FPM (50-319526-00)	HL5030 [245] [5] KL476 [70]					
	JD222 [31-027279-00] JD224 (x6) [31-028778-00]	JM5023 JN808 [31-027281-00] →Eng.7485 JN807 [31-027280-00] →Eng.7485 JM5024 Eng.4081111 →		HR815	NA5163 32x47x10mm, FPM NA5068	KA738 [13]					
	JD018 [31-027300-00] JA829 (x4) [31-022278-00]	JN806 (MVQ) KV102	JJ452 (MVQ) KV086			KA350 [13] KD383 [91]					
	JD016 JD015 [31-027276-00] JE696 [32-202195-10]	JN812 [31-027274-00]	JJ452 (MVQ) KV086	HR363							

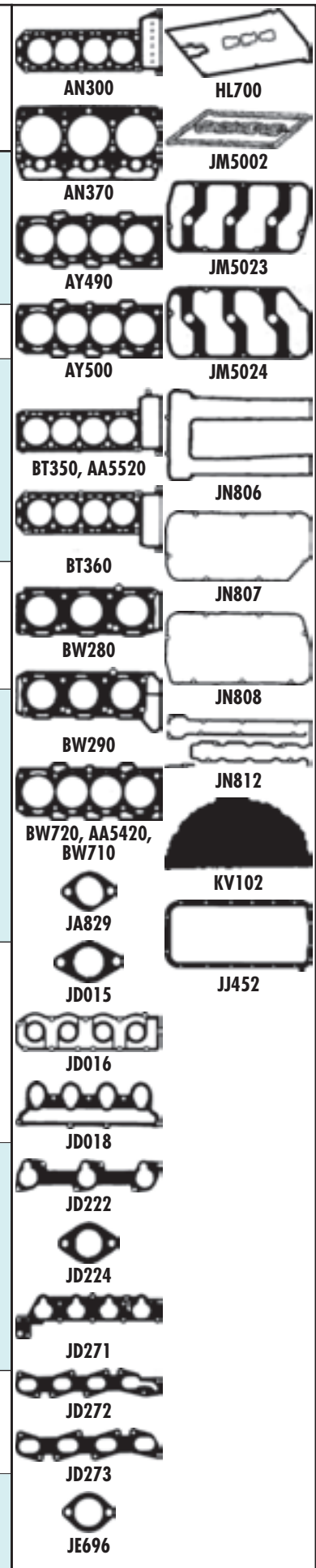

ALFA ROMEO





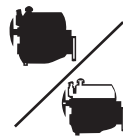



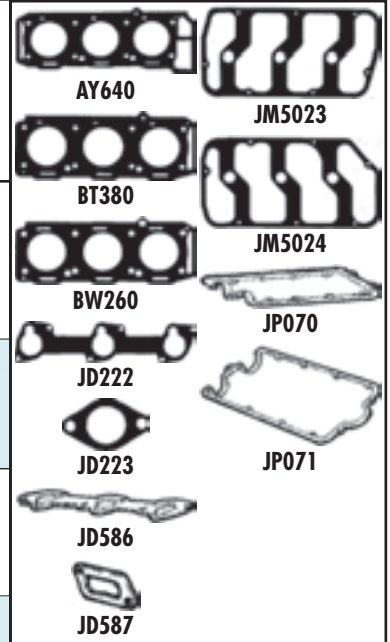

KW/PS









Spider 2.2L JTS					09/06 →	164	AG9580 (MLS)		
939 A5.000	2198	4	86.00	Injection, DOHC		136/185	(30-030344-00)		
Spider Convertible 3.0L V6					10/00 →04/05	165	BT380 (Fibre), 1.65mm	CY640	FY640
Spider Convertible 3.0L V6 24V					01/99 →10/00		(30-027519-00)	(21-27518-20/0)	
AR 16105	2959	6	93.00	V6		160/218	AY640 (Fibre), 1.65mm		
AR 16102	2959	6	93.00	V6		162/220	(30-027518-10)		
Spider Convertible 3.0L V6					06/95 →04/05	166	BW260 (Fibre)	DW261	GW261 [8]
AR 16101	2959	6	93.00	V6		141/192	(30-025873-20)	(21-25873-23/0)	
Spider Convertible 3.2L V6 24V					04/03 →04/05	167	BT380 (Fibre), 1.65mm	CY640	FY640
936 A6.000	3179	6	93.00	DOHC, V6		176/240	(30-027519-00)	(21-27518-20/0)	
							AY640 (Fibre), 1.65mm		
							(30-027518-10)		

	KG5337 (50-350435-00) (MVQ) JD5868 (31-030346-00)					
	JD586 (x2) JD587 (x6) (31-026982-00)	JP071 JP070		HR800	NA5163 (x4) 32x47x10mm, FPM NA5068	KA738 [13]
	JD222 (x2) (31-027279-00) JD223 (x6) (31-027287-00)	JM5023 JM5024 Eng.4081111 →		HR815	NJ951 (x2) 32x50x8mm, FPM NA5068	KA738 [13]
				HR800	NA5163 (x4) 32x47x10mm, FPM NA5068	



		CC			9			CC			9
1B	Petrol	2226	5	81.00	152	AEB	Petrol	1781	4	81.00	79
1B	Petrol	2226	5	81.00	51	AEB	Petrol	1781	4	81.00	98
1T	Diesel	2461	5	81.00	45	AEH	Petrol	1595	4	81.00	59
1Y	Diesel	1896	4	79.50	11	AEJ	Petrol	2771	6	82.50	118
1Z	Diesel	1896	4	79.50	101	AEJ	Petrol	2771	6	82.50	122
1Z	Diesel	1896	4	79.50	12	AEL	Diesel	2461	5	81.00	115
1Z	Diesel	1896	4	79.50	127	AFB	Diesel	2496	6	78.30	113
1Z	Diesel	1896	4	79.50	83	AFB	Diesel	2496	6	78.30	120
2B	Petrol	2226	5	81.00	51	AFB	Diesel	2496	6	78.30	121
3A	Petrol	1984	4	82.50	140	AFB	Diesel	2496	6	78.30	91
3A	Petrol	1984	4	82.50	15	AFF	Diesel	1896	4	79.50	81
3B	Petrol	2226	5	81.00	145	AFF	Diesel	1896	4	79.50	85
3B	Petrol	2226	5	81.00	50	AFN	Diesel	1896	4	79.50	102
3D	Diesel	2370	5	79.50	44	AFN	Diesel	1896	4	79.50	84
4B	Petrol	1781	4	81.00	30	AFY	Petrol	1781	4	81.00	74
6A	Petrol	1984	4	82.50	141	AFY	Petrol	1781	4	81.00	96
6A	Petrol	1984	4	82.50	17	AGA	Petrol	2393	6	81.00	111
AAD	Petrol	1984	4	82.50	139	AGA	Petrol	2393	6	81.00	90
AAD	Petrol	1984	4	82.50	14	AGN	Petrol	1781	4	81.00	61
AAD	Petrol	1984	4	82.50	37	AGR	Diesel	1896	4	79.50	65
AAE	Petrol	1984	4	82.50	104	AGU	Petrol	1781	4	81.00	62
AAE	Petrol	1984	4	82.50	32	AHF	Diesel	1896	4	79.50	66
AAH	Petrol	2771	6	82.50	118	AHH	Diesel	1896	4	79.50	83
AAH	Petrol	2771	6	82.50	122	AHL	Petrol	1595	4	81.00	73
AAH	Petrol	2771	6	82.50	132	AHU	Diesel	1896	4	79.50	101
AAH	Petrol	2771	6	82.50	148	AHU	Diesel	1896	4	79.50	127
AAH	Petrol	2771	6	82.50	22	AHU	Diesel	1896	4	79.50	83
AAH	Petrol	2771	6	82.50	47	AJG	Petrol	2393	6	81.00	111
AAH	Petrol	2771	6	82.50	94	AJG	Petrol	2393	6	81.00	90
AAN	Petrol	2226	5	81.00	108	AJL	Petrol	1781	4	81.00	76
AAN	Petrol	2226	5	81.00	41	AJL	Petrol	1781	4	81.00	96
AAR	Petrol	2309	5	82.50	109	AJM	Diesel	1896	4	79.50	80
AAR	Petrol	2309	5	82.50	110	AJM	Diesel	1896	4	79.50	99
AAR	Petrol	2309	5	82.50	42	AJP	Petrol	1781	4	81.00	97
AAS	Diesel	2370	5	79.50	44	AJQ	Petrol	1781	4	81.00	153
AAT	Diesel	2461	5	81.00	115	AJQ	Petrol	1781	4	81.00	62
AAT	Diesel	2461	5	81.00	45	AKE	Diesel	2496	6	78.30	112
AAZ	Diesel	1896	4	79.50	11	AKE	Diesel	2496	6	78.30	120
ABB	Petrol	1595	4	81.00	4	AKE	Diesel	2496	6	78.30	124
ABC	Petrol	2598	6	82.50	116	AKE	Diesel	2496	6	78.30	91
ABC	Petrol	2598	6	82.50	131	AKL	Petrol	1595	4	81.00	59
ABC	Petrol	2598	6	82.50	147	AKN	Diesel	2496	6	78.30	113
ABC	Petrol	2598	6	82.50	21	AKN	Diesel	2496	6	78.30	120
ABC	Petrol	2598	6	82.50	46	AKN	Diesel	2496	6	78.30	121
ABC	Petrol	2598	6	82.50	92	AKN	Diesel	2496	6	78.30	91
ABK	Petrol	1984	4	82.50	105	ALF	Petrol	2393	6	81.00	111
ABK	Petrol	1984	4	82.50	129	ALF	Petrol	2393	6	81.00	90
ABK	Petrol	1984	4	82.50	139	ALH	Diesel	1896	4	79.50	65
ABK	Petrol	1984	4	82.50	16	ALT	Petrol	1984	4	82.50	103
ABK	Petrol	1984	4	82.50	37	ALT	Petrol	1984	4	82.50	88
ABM	Petrol	1595	4	81.00	3	ALW	Petrol	2393	6	81.00	111
ABP	Diesel	2461	5	81.00	45	ALZ	Petrol	1595	4	81.00	72
ABT	Petrol	1984	4	82.50	13	AMB	Petrol	1781	4	81.00	78
ABY	Petrol	2226	5	81.00	145	AMF	Diesel	1422	3	79.50	55
ABY	Petrol	2226	5	81.00	19	AMK	Petrol	1781	4	81.00	62
ACE	Petrol	1984	4	82.50	106	AML	Petrol	2393	6	81.00	111
ACE	Petrol	1984	4	82.50	128	AML	Petrol	2393	6	81.00	90
ACE	Petrol	1984	4	82.50	142	AMM	Petrol	2393	6	81.00	111
ACE	Petrol	1984	4	82.50	18	AMM	Petrol	2393	6	81.00	90
ACE	Petrol	1984	4	82.50	38	AMU	Petrol	1781	4	81.00	153
ACZ	Petrol	2598	6	82.50	116	ANA	Petrol	1595	4	81.00	73
ACZ	Petrol	2598	6	82.50	131	ANB	Petrol	1781	4	81.00	79
ACZ	Petrol	2598	6	82.50	46	ANB	Petrol	1781	4	81.00	98
ADA	Petrol	1595	4	81.00	3	ANQ	Petrol	1781	4	81.00	97
ADP	Petrol	1595	4	81.00	73	ANY	Diesel	1191	3	76.50	53
ADR	Petrol	1781	4	81.00	126	APC	Petrol	2393	6	81.00	111
ADR	Petrol	1781	4	81.00	75	APF	Petrol	1595	4	81.00	59
ADR	Petrol	1781	4	81.00	96	APP	Petrol	1781	4	81.00	153
ADU	Petrol	2226	5	81.00	19	APP	Petrol	1781	4	81.00	62

		CC			9			CC			9
APS	Petrol	2393	6	81.00	111	BCZ	Diesel	2496	6	78.30	91
APS	Petrol	2393	6	81.00	90	BDB	Petrol	3189	6	84.00	71
APT	Petrol	1781	4	81.00	75	BDG	Diesel	2496	6	78.30	114
APU	Petrol	1781	4	81.00	79	BDG	Diesel	2496	6	78.30	91
APU	Petrol	1781	4	81.00	98	BDH	Diesel	2496	6	78.30	112
APX	Petrol	1781	4	81.00	153	BDH	Diesel	2496	6	78.30	91
APY	Petrol	1781	4	81.00	62	BDV	Petrol	2393	6	81.00	111
APZ	Petrol	2393	6	81.00	111	BDV	Petrol	2393	6	81.00	90
APZ	Petrol	2393	6	81.00	90	BEX	Petrol	1781	4	81.00	78
AQA	Petrol	1781	4	81.00	62	BFB	Petrol	1781	4	81.00	78
AQE	Petrol	1781	4	81.00	97	BFC	Diesel	2496	6	78.30	114
ARG	Petrol	1781	4	81.00	75	BFC	Diesel	2496	6	78.30	91
ARH	Petrol	1781	4	81.00	97	BFQ	Petrol	1595	4	81.00	57
ARJ	Petrol	2393	6	81.00	111	BFV	Petrol	1781	4	81.00	153
ARJ	Petrol	2393	6	81.00	90	BGU	Petrol	1595	4	81.00	58
ARK	Petrol	1781	4	81.00	79	BHC	Diesel	1422	3	79.50	55
ARK	Petrol	1781	4	81.00	98	BHE	Petrol	3189	6	84.00	154
ARM	Petrol	1595	4	81.00	73	BKB	Petrol	1781	4	81.00	78
ARN	Petrol	2393	6	81.00	111	BKC	Diesel	1896	4	79.50	64
ARX	Petrol	1781	4	81.00	62	BKD	Diesel	1968	4	81.00	69
ARY	Petrol	1781	4	81.00	153	BKE	Diesel	1896	4	79.50	82
ARY	Petrol	1781	4	81.00	62	BKN	Diesel	2967	6	83.00	95
ARZ	Petrol	1781	4	81.00	62	BLB	Diesel	1968	4	81.00	107
ASB	Diesel	2967	6	83.00	119	BLB	Diesel	1968	4	81.00	89
ASB	Diesel	2967	6	83.00	123	BLF	Petrol	1598	4	76.50	60
ASB	Diesel	2967	6	83.00	95	BLP	Petrol	1598	4	76.50	60
ASM	Petrol	2393	6	81.00	111	BLR	Petrol	1984	4	82.50	68
ASV	Diesel	1896	4	79.50	66	BLX	Petrol	1984	4	82.50	68
ASZ	Diesel	1896	4	79.50	63	BLY	Petrol	1984	4	82.50	68
ATC	Petrol	1781	4	81.00	153	BMB	Petrol	1984	4	82.50	68
ATD	Diesel	1896	4	79.50	63	BMJ	Petrol	3189	6	84.00	71
ATJ	Diesel	1896	4	79.50	80	BMK	Diesel	2967	6	83.00	119
ATL	Diesel	1422	3	79.50	55	BMM	Diesel	1968	4	81.00	67
AUA	Petrol	1390	4	76.50	54	BMN	Diesel	1968	4	81.00	70
AUL	Petrol	1781	4	81.00	62	BNA	Diesel	1968	4	81.00	107
AUM	Petrol	1781	4	81.00	153	BNA	Diesel	1968	4	81.00	89
AUM	Petrol	1781	4	81.00	62	BND	Diesel	2496	6	78.30	112
AUQ	Petrol	1781	4	81.00	153	BNG	Diesel	2967	6	83.00	119
AUQ	Petrol	1781	4	81.00	62	BNG	Diesel	2967	6	83.00	123
AVB	Diesel	1896	4	79.50	82	BPF	Petrol	3189	6	84.00	154
AVF	Diesel	1896	4	79.50	100	BPP	Diesel	2698	6	81.40	117
AVF	Diesel	1896	4	79.50	82	BPP	Diesel	2698	6	81.40	93
AVG	Diesel	1896	4	79.50	102	BPW	Diesel	1968	4	81.00	86
AVG	Diesel	1896	4	79.50	84	BRB	Diesel	1896	4	79.50	82
AVJ	Petrol	1781	4	81.00	77	BRD	Diesel	1968	4	81.00	89
AVU	Petrol	1595	4	81.00	57	BRE	Diesel	1968	4	81.00	107
AVV	Petrol	1781	4	81.00	75	BRE	Diesel	1968	4	81.00	89
AWA	Petrol	1984	4	82.50	87	BRF	Diesel	1968	4	81.00	107
AWL	Petrol	1781	4	81.00	98	BRF	Diesel	1968	4	81.00	89
AWP	Petrol	1781	4	81.00	153	BSE	Petrol	1595	4	81.00	58
AWT	Petrol	1781	4	81.00	79	BSF	Petrol	1595	4	81.00	58
AWT	Petrol	1781	4	81.00	98	BSG	Diesel	2698	6	81.40	117
AWX	Diesel	1896	4	79.50	100	BSG	Diesel	2698	6	81.40	93
AWX	Diesel	1896	4	79.50	82	BUB	Petrol	3189	6	84.50	154
AXR	Diesel	1896	4	79.50	63	BUB	Petrol	3189	6	84.50	71
AXW	Petrol	1984	4	82.50	68	BUG	Diesel	2967	6	83.00	149
AYM	Diesel	2496	6	78.30	113	BUN	Diesel	2967	6	83.00	149
AYM	Diesel	2496	6	78.30	91	BVP	Petrol	1781	4	81.00	153
AZV	Diesel	1968	4	81.00	69	BVR	Petrol	1781	4	81.00	153
BAD	Petrol	1598	4	76.50	56	BVY	Petrol	1984	4	82.50	68
BAG	Petrol	1598	4	76.50	60	BVZ	Petrol	1984	4	82.50	68
BAM	Petrol	1781	4	81.00	153	CAGB	Diesel	1968	4	81.00	107
BAM	Petrol	1781	4	81.00	62	CANB	Diesel	2698	6	83.00	117
BAU	Diesel	2496	6	78.30	112	CASB	Diesel	2967	6	83.00	149
BAU	Diesel	2496	6	78.30	124	CDYB	Diesel	2967	6	83.00	119
BAU	Diesel	2496	6	78.30	91	CN	Diesel	1986	5	76.50	34
BBY	Petrol	1390	4	76.50	54	CY	Diesel	1588	4	76.50	23
BCZ	Diesel	2496	6	78.30	114	DD	Petrol	1781	4	81.00	133
BCZ	Diesel	2496	6	78.30	125	DE	Diesel	1986	5	76.50	35



CC



9



CC



9











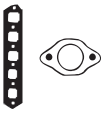

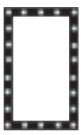

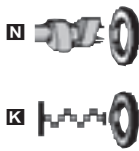

DR	Petrol	1781	4	81.00	29
DS	Petrol	1781	4	81.00	133
DS	Petrol	1781	4	81.00	137
DS	Petrol	1781	4	81.00	28
DT	Petrol	1595	4	81.00	1
DZ	Petrol	1781	4	81.00	134
DZ	Petrol	1781	4	81.00	9
GV	Petrol	2144	5	79.50	150
HP	Petrol	1994	5	81.00	138
HX	Petrol	2226	5	81.00	39
HY	Petrol	2144	5	81.00	144
HY	Petrol	2144	5	81.00	26
JK	Diesel	1588	4	76.50	5
JN	Petrol	1781	4	81.00	10
JN	Petrol	1781	4	81.00	136
JN	Petrol	1781	4	81.00	137
JS	Petrol	1994	5	81.00	138
JT	Petrol	2226	5	81.00	144
JT	Petrol	2226	5	81.00	26
JV	Petrol	1781	4	81.00	133
JW	Petrol	1781	4	81.00	28
KG	Petrol	2144	5	79.50	49
KP	Petrol	1994	5	81.00	31
KU	Petrol	2226	5	81.00	39
KV	Petrol	2226	5	81.00	144
KV	Petrol	2226	5	81.00	26
KX	Petrol	2226	5	81.00	144
KX	Petrol	2226	5	81.00	26
KZ	Petrol	2226	5	81.00	39
MB	Petrol	2226	5	81.00	152
MC	Petrol	2226	5	81.00	40
MC	Petrol	2226	5	81.00	51
NC	Diesel	1986	5	76.50	36
NE	Petrol	1781	4	81.00	10
NE	Petrol	1781	4	81.00	137
NF	Petrol	2309	5	82.50	43
NF	Petrol	2309	5	82.50	52
NG	Petrol	2309	5	82.50	130
NG	Petrol	2309	5	82.50	146
NG	Petrol	2309	5	82.50	20
NG	Petrol	2309	5	82.50	27
NM	Petrol	1994	5	81.00	143
NM	Petrol	1994	5	81.00	25
NP	Petrol	1781	4	81.00	28
PH	Petrol	1781	4	81.00	30
PM	Petrol	1781	4	81.00	10
PP	Petrol	1595	4	81.00	1
PS	Petrol	1994	5	81.00	24
PV	Petrol	1781	4	81.00	136
PX	Petrol	2226	5	81.00	39
RA	Diesel	1588	4	76.50	23
RA	Diesel	1588	4	76.50	6
RN	Petrol	1595	4	81.00	2
RR	Petrol	2226	5	81.00	151
RS	Petrol	1781	4	81.00	29
RT	Petrol	1994	5	81.00	33
RU	Petrol	1781	4	81.00	7
SA	Petrol	1595	4	81.00	1
SB	Diesel	1588	4	76.50	23
SB	Diesel	1588	4	76.50	6
SD	Petrol	1847	4	82.50	8
SF	Petrol	1781	4	81.00	135
SF	Petrol	1781	4	81.00	7
SH	Petrol	1781	4	81.00	28
SK	Petrol	1994	5	81.00	138
SL	Petrol	1994	5	81.00	31
WC	Petrol	2144	5	79.50	48
WR	Petrol	2144	5	79.50	150



KW/PS



80 1.6L					08/78 → 09/91	1	BM360 (Fibre)	DM360	EG873
PP	1595	4	81.00			51/69	30-026807-30	21-26807-24/0	
SA	1595	4	81.00	SOHC		54/73			
DT	1595	4	81.00	SOHC		55/75			
80 1.6L					09/86 → 08/91	2	BM360 (Fibre)	DM363 [83]	EG873
RN	1595	4	81.00			55/75	30-026807-30	21-26807-27/0	
80 1.6L					09/91 → 12/94	3	BM360 (Fibre)	DM361 [83]	ES471
80 1.6L E					06/93 → 12/94				
80 Avant 1.6L E					06/93 → 01/96				
ABM	1595	4	81.00	Monomotronic		52/71	30-026807-30	21-26807-22/0 → Ch.8C-P-185 000	→ Ch.8C-P-220 000
ADA	1595	4	81.00			74/100			
								22-27500-01/0 Ch.8C-P-220 001 →	
80 1.6L					08/90 → 10/91	4	BM360 (Fibre)	DM361 [83]	EG873
ABB	1595	4	81.00	K-Jetronic		75/102	30-026807-30	21-26807-22/0	→ Ch.8C-P-220 000
80 1.6L Diesel					09/86 → 08/91	5	BN940 (Fibre), 1.53mm, 1 Hole	DD501▲ [83]	EG873
JK	1588	4	76.50			40/54	30-026230-30	21-25753-26/0	
							BN950 (Fibre), 1.57mm, 2 Holes		
							30-026231-30		
							BN960 (Fibre), 1.61mm, 3 Holes		
							30-026232-30		
80 1.6L TD Diesel					09/86 → 08/91	6	BN940 (Fibre), 1.53mm, 1 Hole	DD502▲ [83]	EG873
RA/SB	1588	4	76.50			59/80	30-026230-30	(21-25753-27/0)	
							BN950 (Fibre), 1.57mm, 2 Holes		
							30-026231-30		
							BN960 (Fibre), 1.61mm, 3 Holes		
							30-026232-30		
80 1.8L					02/86 → 01/90	7	BM360 (Fibre)	DM360	EG873
80 1.8L S					09/86 → 12/90				
80 1.8L S quattro					09/86 → 07/90				
RU	1781	4	81.00			55/75	30-026807-30	21-26807-24/0	
SF	1781	4	81.00			64/87			

								
HBS043 Ⓢ [22-39001B] M11x1.50x95mm (x10)	JC478 ■ 31-026397-00 PA459 ■ 50-024870-00 (NBR) JC152 ■ (x4) 31-026555-00	HL457 ■ [79] 24-25753-01/0 (Cork) HM5053 ■ [80] 24-28543-00/0 (ACM)	JJ140 [31-026554-10]	HR569 ■ 24-30667-00/0	NA5001 32x47x10mm, FPM (50-303185-50) NA5001 ■ 32x47x10mm, FPM (50-303185-50) NA5133 ■ 85x105x11mm, FPM (24-30727-87/0)	HL5020 [245]■ KA5020 [13]		 BM360  BN940, BN950, BN960  JC152  JC243  JC478  JE689  PA459  HL457  JP024  JJ140
HBS043 Ⓢ [22-39001B] M11x1.50x95mm (x10)	JC478 ■ 31-026397-00 PA459 ■ 50-024870-00 (NBR) JC152 ■ (x4) 31-026555-00 Ⓢ JE689 [31-024039-00]	HL457 ■ [79] 24-25753-01/0 (Cork) HM5053 ■ [80] 24-28543-00/0 (ACM)	JJ140 [31-026554-10]	HR569 ■ 24-30667-00/0	NA5001 32x47x10mm, FPM (50-303185-50) NA5001 ■ 32x47x10mm, FPM (50-303185-50) NA5133 ■ 85x105x11mm, FPM (24-30727-87/0)	HL5020 [245]■ KA5020 [13]		
HBS043 Ⓢ [22-39001B] M11x1.50x95mm (x10)	JC478 ■ 31-026397-00 PA459 ■ 50-024870-00 (NBR) JC152 ■ (x4) 31-026555-00 Ⓢ JE689 [31-024039-00]	JP024 50-027505-00 Ch.8C-P-185 001→ HL457 ■ [79] 24-25753-01/0 (Cork) →Ch.8C-P-185 000	JJ140 [31-026554-10] →Ch.8C-P-220 000	HR569 ■ 24-30667-00/0 →Eng.ADA-034 669 HR816 ■ 24-30653-85/0 Eng.ADA-034 670→	NA5001 32x47x10mm, FPM (50-303185-50) NA5001 ■ 32x47x10mm, FPM (50-303185-50) NA5133 ■ 85x105x11mm, FPM (24-30727-87/0)	HL5020 [245]■		
HBS043 Ⓢ [22-39001B] M11x1.50x95mm (x10)	JC478 ■ 31-026397-00 JC152 ■ (x4) 31-026555-00 Ⓢ JE689 [31-024039-00]	JP024 50-027505-00 Ch.8C-P-185 001→ HL457 ■ [79] 24-25753-01/0 (Cork) →Ch.8C-P-185 000 HM5053 ■ [80] 24-28543-00/0 (ACM) →Ch.8C-P-185 000	JJ140 [31-026554-10] →Ch.8C-P-220 000	HR569 ■ 24-30667-00/0	NA5001 32x47x10mm, FPM (50-303185-50) NA5001 ■ 32x47x10mm, FPM (50-303185-50) NA5133 ■ 85x105x11mm, FPM (24-30727-87/0)	HL5020 [245]■ KA5020 [13]		
HBS018 Ⓢ [22-390024B] M12x1.75x115mm (x10)	JC478 ■ 31-026397-00 JC152 ■ (x4) 31-026555-00	HL457 ■ [79] 24-25753-01/0 (Cork) HM5053 ■ [80] 24-28543-00/0 (ACM)	JJ140 [31-026554-10]	HR569 ■ 24-30667-00/0	NA5001 32x47x10mm, FPM (50-303185-50) NA5001 ■ 32x47x10mm, FPM (50-303185-50) NA5133 ■ 85x105x11mm, FPM (24-30727-87/0)	HL5020 [245]■ KA5020 [13]		
HBS018 Ⓢ [22-390024B] M12x1.75x115mm (x10)	JC243 ■ [31-026727-00] JC152 ■ (x4) 31-026555-00	HL457 ■ [79] 24-25753-01/0 (Cork) HM5053 ■ [80] 24-28543-00/0 (ACM)	JJ140 [31-026554-10]	HR569 ■ 24-30667-00/0	NA5001 32x47x10mm, FPM (50-303185-50) NA5001 ■ 32x47x10mm, FPM (50-303185-50) NA5133 ■ 85x105x11mm, FPM (24-30727-87/0)	HL5020 [245]■ KA5020 [13] NA5278 [54]		
HBS043 Ⓢ [22-39001B] M11x1.50x95mm (x10)	JC478 ■ 31-026397-00 PA459 ■ 50-024870-00 (NBR) JC152 ■ (x4) 31-026555-00 Ⓢ JE689 [31-024039-00]	HL457 ■ [79] 24-25753-01/0 (Cork) HM5053 ■ [80] 24-28543-00/0 (ACM)	JJ140 [31-026554-10]	HR569 ■ 24-30667-00/0	NA5001 32x47x10mm, FPM (50-303185-50) NA5001 ■ 32x47x10mm, FPM (50-303185-50) NA5133 ■ 85x105x11mm, FPM (24-30727-87/0)	HL5020 [245]■		











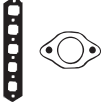

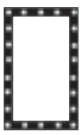

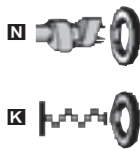

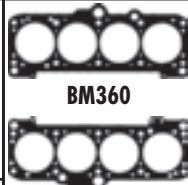





































































AUDI



KW/PS



80 1.8L 09/86 → 07/88 8						BT810 (Fibre) 30-027257-20	DT813 21-27257-20/0	EG873
80 1.8L quattro 09/86 → 08/90								
SD	1847	4	82.50		83/113			
80 1.8L E 06/86 → 08/91 9						BM360 (Fibre) 30-026807-30	DM360 21-26807-24/0	EG873
80 1.8L E quattro 09/86 → 08/91								
80 1.8L GTE 10/84 → 08/86								
80 1.8L GTE quattro 08/84 → 08/86								
DZ	1781	4	81.00		82/111			
80 1.8L S 09/86 → 10/91 10						BM360 (Fibre) 30-026807-30	DM360 21-26807-24/0 NE/PM DM363 [83] 21-26807-27/0 JN	EG873
80 1.8L S quattro 09/86 → 09/91								
JN/NE/PM	1781	4	81.00	SOHC	66/89			
80 1.9L D Diesel 08/89 → 08/91 11						BV850 (MLS), 1.53mm, 1 Hole 30-028545-00	DV850▲ 21-26557-20/0	ECO30 [8] 22-26384-04/0
80 1.9L TD Diesel 09/91 → 12/94								
80 Avant 1.9L TD Diesel 09/91 → 12/94								
1Y	1896	4	79.50		47/64			
AAZ	1896	4	79.50		55/75			
80 1.9L TDI Diesel 09/91 → 12/94 12						BX800 (MLS), 1.45mm, 1 Hole 30-028686-00	DX800▲ 21-27921-20/0 → Eng. 1Z 770 000	ECO30 [8] 22-26384-04/0
80 Avant 1.9L TDI Diesel 07/92 → 01/96								
1Z	1896	4	79.50		66/89			
80 2.0L 09/91 → 12/94 13						BT810 (Fibre) 30-027257-20	DT814 21-26470-20/0 → Eng. 8C-P-185 164	EB970 22-27500-01/0
80 Avant 2.0L 07/92 → 01/96								
ABT	1984	4	82.50	Monomotronic	66/89			
							DT81C 21-27257-26/0 Eng. 8C-P-185 165 →	







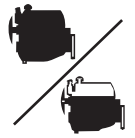



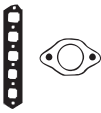

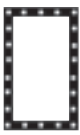

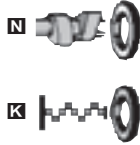

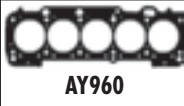
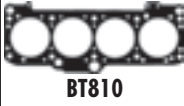
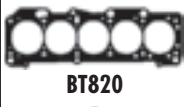
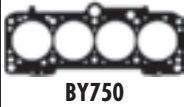



									
HBS043 ⊕ (22-39001B) M11x1.50x95mm (x10)	JC152  (x4) 31-026555-00  JE689 (31-024039-00)	HL457  [79] 24-25753-01/0 (Cork) HM5053  [80] 24-28543-00/0 (ACM)	JJ140 (31-026554-10)	HR569  24-30667-00/0	 NA5001 32x47x10mm, FPM (50-303185-50)  NA5001  32x47x10mm, FPM (50-303185-50)  NA5133  85x105x11mm, FPM (24-30727-87/0)	HL5020 [245]  KA5020 [13]		BM360 BT810 BV850, BV860, BV870 BX800, BX810, BX820 JC152 JC478 JD170 JD482 JD606 JE689 PA459 HL457 JN914 JP003 JP024 JH5023 JJ140	
HBS043 ⊕ (22-39001B) M11x1.50x95mm (x10)	JC478  31-026397-00 JC152  (x4) 31-026555-00  JE689 (31-024039-00)	HL457  [79] 24-25753-01/0 (Cork) HM5053  [80] 24-28543-00/0 (ACM)	JJ140 (31-026554-10)	HR569  24-30667-00/0	 NA5001  32x47x10mm, FPM (50-303185-50)  NA5001  32x47x10mm, FPM (50-303185-50)  NA5133  85x105x11mm, FPM (24-30727-87/0)	HL5020 [245]  KA5020 [13]		BT810 BV850, BV860, BV870 BX800, BX810, BX820 JC152 JC478 JD170 JD482 JD606 JE689 PA459 HL457 JN914 JP003 JP024 JH5023 JJ140	
HBS043 ⊕ (22-39001B) M11x1.50x95mm (x10)	JC478  31-026397-00 NE/PM PA459  50-024870-00 (NBR) NE/PM JC152  (x4) 31-026555-00  JE138 (31-024515-00) JN/PM  JE689 (31-024039-00) NE	HL457  [79] 24-25753-01/0 (Cork) HM5053  [80] 24-28543-00/0 (ACM)	JJ140 (31-026554-10)	HR569  24-30667-00/0	 NA5001 32x47x10mm, FPM (50-303185-50)  NA5001  32x47x10mm, FPM (50-303185-50)  NA5133  85x105x11mm, FPM (24-30727-87/0)	HL5020 [245]  KA5020 [13]		JC478 JD170 JD482 JD606 JE689 PA459 HL457 JN914 JP003 JP024 JH5023 JJ140	
HBS018 ⊕ (22-39024B) M12x1.75x115mm (x10)	JD170  31-026556-10 JC152  (x4) 31-026555-00  JE5076 (31-028373-00)	JN914 50-026557-10 HM5058  24-26557-00/0	JH5023 (31-029043-00)	HR569  24-30667-00/0	 NA5001 32x47x10mm, FPM (50-303185-50)  NA5001  32x47x10mm, FPM (50-303185-50)  NA5133  85x105x11mm, FPM (24-30727-87/0)	HL5020 [245]  NA5278 [54]		JE689 PA459 HL457 JN914 JP003 JP024 JH5023 JJ140	
HBS018 ⊕ (22-39024B) M12x1.75x115mm (x10)	JD170  31-026556-10 JC152  (x4) 31-026555-00	JP003 50-027921-00	JJ609 (50-027500-00) (ACM)	HR569  24-30667-00/0 →Eng.1Z 770 000 HR816  24-30653-85/0 Eng.1Z 770 001→	 NA5001 32x47x10mm, FPM (50-303185-50)  NA5001  32x47x10mm, FPM (50-303185-50)  NA5133  85x105x11mm, FPM (24-30727-87/0)	HL5020 [245]  NA5278 [54]		JP003 JP024 JH5023 JJ140	
HBS043 ⊕ (22-39001B) M11x1.50x95mm (x10)	JD482  (31-027351-00) PA459  50-024870-00 (NBR) JC152  (x4) 31-026555-00 JD606  (31-028918-00)	JP024 50-027505-00 Eng.8C-P-185 165→ HL457  [79] 24-25753-01/0 (Cork) →Ch.8C-P-185 164 HM5053  [80] 24-28543-00/0 (ACM) →Eng.8C-P-185 164	JJ140 (31-026554-10)	HR569  24-30667-00/0 →Eng.ABT 246 861 HR816  24-30653-85/0 Eng.ABT 246 862→	 NA5001 32x47x10mm, FPM (50-303185-50)  NA5001  32x47x10mm, FPM (50-303185-50)  NA5133  85x105x11mm, FPM (24-30727-87/0)	HL5020 [245] 		JH5023 JJ140	



KW/PS



80 2.0L 10/90 → 08/91 14						BT810 (Fibre) 30-027257-20	DT814 21-26470-20/0	ES471
80 2.0L quattro 10/90 → 08/91								
AAD	1984	4	82.50	K-Motronic	85/116			
80 2.0L E 08/88 → 10/90 15						BT810 (Fibre) 30-027257-20	DT813 21-27257-20/0	EB970 22-27500-01/0
80 2.0L E quattro 08/88 → 09/90								
80 2.0L quattro 10/90 → 08/91								
3A	1984	4	82.50	K-Motronic	83/113			
80 2.0L E 09/91 → 12/94 16						BT810 (Fibre) 30-027257-20	DT814 21-26470-20/0 → Ch.8P-C-185 164 DT81C 21-27257-26/0 Ch.8P-C-185 165 →	EB970 22-27500-01/0
80 2.0L E quattro 09/91 → 12/94								
80 Avant 2.0L E 07/92 → 01/96								
ABK	1984	4	82.50	Digifant	85/116			
80 2.0L E 16V 03/90 → 09/91 17						BT810 (Fibre) 30-027257-20	DT813 21-27257-20/0	ES471
80 2.0L E 16V quattro 03/90 → 08/91								
6A	1984	4	82.50	KE-Motronic	101/137			
80 2.0L E 16V 08/92 → 12/94 18						BY750 (MLS) 30-027930-00	DY751 21-27930-24/0 → Eng.ACE 017 542 DY752 21-27930-25/0 Eng.ACE 017 543 →	
80 2.0L E 16V quattro 04/92 → 12/94								
80 Avant 2.0L E 16V 02/93 → 01/96								
80 Avant 2.0L E 16V quattro 12/92 → 07/95								
ACE	1984	4	82.50	KE-Motronic	103/140			
80 2.2L S2 quattro 02/93 → 12/94 19						AY960 (MLS) 30-028016-00	CY960 21-28016-20/0	ECO10 (22-26274-00/0)
80 Avant 2.2L RS2 quattro 03/94 → 05/95								
80 Avant 2.2L S2 quattro 02/93 → 07/95								
ABY	2226	5	81.00		169/230			
ADU	2226	5	81.00		232/316			
80 2.3L E 09/91 → 12/94 20						BT820 (Fibre)	DT820 21-26082-21/0 → Ch.8A L 200 000	EX995 (22-23856-06/0)
80 2.3L E quattro 09/91 → 12/94								
80 Avant 2.3L E 07/92 → 01/96								
80 Avant 2.3L E quattro 09/91 → 11/94								
NG	2309	5	82.50	SOHC	98-100/ 133- 136			











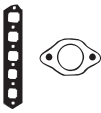

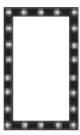

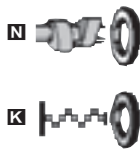













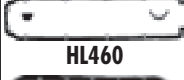

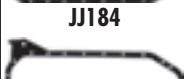









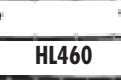

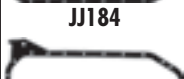











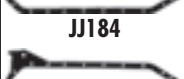





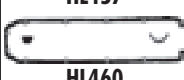

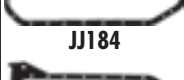

								
HBS043 Ⓢ (22-39001B) M11x1.50x95mm (x10)	JD482 ■ (31-027351-00) JD483 ■ (31-027352-00) JC152 ■ (x4) 31-026555-00 Ⓢ JE689 (31-024039-00)	HL457 ■ [79] 24-25753-01/0 (Cork) HM5053 ■ [80] 24-28543-00/0 (ACM)	JJ140 (31-026554-10)	HR569 ■ 24-30667-00/0	NA5001 32x47x10mm, FPM (50-303185-50) NA5001 ■ 32x47x10mm, FPM (50-303185-50) NA5133 ■ 85x105x11mm, FPM (24-30727-87/0)	HL5020 [245]■		 AY960  BT810  BT820  BY750  JC152  JD171  JD281  JD282  JD482  JD483  JD602  JE689  HL457  HL731  JP024  JJ140  JJ184
HBS043 Ⓢ (22-39001B) M11x1.50x95mm (x10)	JC152 ■ (x4) 31-026555-00 Ⓢ JE689 (31-024039-00)	HL457 ■ [79] 24-25753-01/0 (Cork) HM5053 ■ [80] 24-28543-00/0 (ACM)	JJ140 (31-026554-10)	HR569 ■ 24-30667-00/0	NA5001 32x47x10mm, FPM (50-303185-50) NA5001 ■ 32x47x10mm, FPM (50-303185-50) NA5133 ■ 85x105x11mm, FPM (24-30727-87/0)	HL5020 [245]■		
HBS043 Ⓢ (22-39001B) M11x1.50x95mm (x10)	JD483 ■ (31-027352-00) JC152 ■ (x4) 31-026555-00	JPO24 50-027505-00 Eng.8C-P-185 165 → HM5053 ■ [80] (ACM) 24-28543-00/0 (ACM) →Eng.8C-P-185 164	JJ140 (31-026554-10) JJ609 (50-027500-00) (ACM)	HR569 ■ 24-30667-00/0	NA5001 32x47x10mm, FPM (50-303185-50) NA5001 ■ 32x47x10mm, FPM (50-303185-50) NA5133 ■ 85x105x11mm, FPM (24-30727-87/0)	HL5020 [245]■		
HBS028 Ⓢ (22-39004B) M11x1.50x147mm (x10)	JD281 ■ (31-027904-00) JD282 ■ (x4) (31-026880-00)	HL606 ■ 24-26237-01/0 →Eng.ACE 017 542 HL731 ■ 24-27937-00/0 Eng.ACE 017 543 →	JJ140 (31-026554-10)	HR816 ■ (x2) 24-30653-85/0	NA5001 32x47x10mm, FPM (50-303185-50) NA5001 ■ 32x47x10mm, FPM (50-303185-50) NA5133 ■ 85x105x11mm, FPM (24-30727-87/0)	HL5020 [245]■		
HBS028 Ⓢ (22-39004B) M11x1.50x147mm (x10)	JD281 ■ (31-027904-00) JD282 ■ (x4) (31-026880-00) Ⓢ JE689 (31-024039-00)	HL606 ■ 24-26237-01/0 →Eng.ACE 017 542 HL731 ■ 24-27937-00/0 Eng.ACE 017 543 →	JJ140 (31-026554-10)	HR816 ■ (x2) 24-30653-85/0	NA5001 32x47x10mm, FPM (50-303185-50) NA5001 ■ 32x47x10mm, FPM (50-303185-50) NA5133 ■ 85x105x11mm, FPM (24-30727-87/0)	HL5020 [245]■		
HBS269 Ⓢ (22-33032B) M11x1.50x141.5mm (x12)	JD602 ■ (31-026277-00) JD282 ■ (x5) (31-026880-00) JD603 ■ (31-027514-00)	HL730 ■ 24-27424-00/0	JJ501 (31-027042-00)		NA5001 32x47x10mm, FPM (50-303185-50) NB716 ■ 35x48x10mm, FPM (50-306067-50) NA5133 ■ 85x105x11mm, FPM (24-30727-87/0)			
HBS024 Ⓢ (22-39002B) M11x1.50x95mm (x12)	JD327 ■ ■ (31-026472-00) JD171 ■ ■ 31-027048-00 JC152 ■ (x5) 31-026555-00 Ⓢ JE689 (31-024039-00)	JN438 (50-026864-00) (Rubber) HM5277 ■ 24-26864-00/0 (Rubber) →Ch.8A-L-200 000	JJ184 (31-023856-10)	HR615 ■ 24-30667-05/0	NA5001 32x47x10mm, FPM (50-303185-50) NB716 ■ 35x48x10mm, FPM (50-306067-50) NA5133 ■ 85x105x11mm, FPM (24-30727-87/0)			

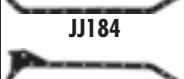

KW/PS

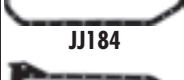

80 2.6L 07/92 → 12/94 21						AY060 (Fibre), 2.00mm (x2) 30-027222-20	DT660 21-27222-20/0 → Ch.8 C-5- 025 820 DY850 21-27222-21/0 Ch.8 C-5- 025 821 →	EY850 (22-28635-00/0) Ch.8 C-5-025 821 →
80 2.6L quattro 06/92 → 12/94								
80 Avant 2.6L 07/92 → 01/96								
80 Avant 2.6L quattro 07/92 → 07/95								
ABC	2598	6	82.50	Injection, V6	110/150			
80 2.8L 09/91 → 12/94 22						AY060 (Fibre), 2.00mm (x2) 30-027222-20	DT660 21-27222-20/0 → Ch.8 C-5- 025 820 DY850 21-27222-21/0 Ch.8 C-5- 025 821 →	EY850 (22-28635-00/0) Ch.8 C-5-025 821 →
80 2.8L quattro 09/91 → 12/94								
80 Avant 2.8L 09/91 → 01/96								
80 Avant 2.8L quattro 08/92 → 07/95								
AAH	2771	6	82.50	MH-Motronic, V6	128/174			
90 1.6L TD Diesel 10/85 → 09/91 23						BN940 (Fibre), 1.53mm, 1 Hole 30-026230-30 BN950 (Fibre), 1.57mm, 2 Holes 30-026231-30 BN960 (Fibre), 1.61mm, 3 Holes 30-026232-30	DD502▲ [83] (21-25753-27/0)	EG873
CY	1588	4	76.50		51/69			
RA/SB	1588	4	76.50		59/80			
90 2.0L 07/88 → 09/91 24						BM840 (Fibre) 30-026326-10		EX995 (22-23856-06/0)
PS	1994	5	81.00	KE-Jetronic	85/116			
90 2.0L 20 V 08/89 → 07/91 25						AY960 (MLS) 30-028016-00	CY960 21-28016-20/0	ECO10 (22-26274-00/0)
90 2.0L 20 V quattro 08/88 → 09/91								
NM	1994	5	81.00		118/160			
90 2.2L 10/84 → 03/87 26						BM840 (Fibre) 30-026326-10	DM840 (21-26326-22/0)	EX995 (22-23856-06/0)
90 2.2L E 04/87 → 07/91								
90 2.2L E quattro 11/84 → 09/91								
HY	2144	5	81.00		100/136			
KX	2226	5	81.00		85/116			
JT	2226	5	81.00		88/120			
KV	2226	5	81.00		100/136			
90 2.3L E 04/87 → 09/91 27						BT820 (Fibre)	DT820 21-26082-21/0 → Ch.8A L 200 000	EX995 (22-23856-06/0)
90 2.3L E quattro 04/87 → 09/91								
NG	2309	5	82.50	SOHC	98-100/ 133- 136			

								
HBS064 Ⓞ (22-39010B) M11x1.50x137mm (x16)		JM5166 50-027936-00 (ACM)	JH5118 (31-028635-00)	HR569 Ⓢ (x2) 24-30667-00/0 →Ch.8C-S-025 820 HR5068 Ⓢ (x2) (24-30653-84/0) Ch.8 C-S- 025 821→	NA5001 32x47x10mm, FPM (50-303185-50) NB716 Ⓢ 35x48x10mm, FPM (50-306067-50) NA5133 Ⓢ 85x105x11mm, FPM (24-30727-87/0)			 AY060  AY960  BM840  BN940, BN950, BN960  BT820  JC152  JC243  JC261  JD171  JD282  JD602  JE160  JE689  HL457  HL460  JJ140  JJ184  JJ501
HBS064 Ⓞ (22-39010B) M11x1.50x137mm (x16)		JM5166 50-027936-00 (ACM)	JH5118 (31-028635-00)	HR569 Ⓢ (x2) 24-30667-00/0 →Ch.8C-S-025 820 HR5068 Ⓢ (x2) (24-30653-84/0) Ch.8 C-S- 025 821→	NA5001 32x47x10mm, FPM (50-303185-50) NB716 Ⓢ 35x48x10mm, FPM (50-306067-50) NA5133 Ⓢ 85x105x11mm, FPM (24-30727-87/0)			 BN940, BN950, BN960  BT820  JC152  JC243  JC261  JD171  JD282  JD602  JE160  JE689  HL457  HL460  JJ140  JJ184  JJ501
HBS018 Ⓞ (22-390024B) M12x1.75x115mm (x10)	JC243 Ⓢ (31-026727-00) JC152 Ⓢ (x4) 31-026555-00 Ⓞ JE160 (31-024869-00)	HL457 Ⓢ [79] 24-25753-01/0 (Cork) HM5053 Ⓢ [80] 24-28543-00/0 (ACM)	JJ140 (31-026554-10)	HR569 Ⓢ 24-30667-00/0	NA5001 32x47x10mm, FPM (50-303185-50) NA5001 Ⓢ 32x47x10mm, FPM (50-303185-50) NA5133 Ⓢ 85x105x11mm, FPM (24-30727-87/0)	HL5020 [245]Ⓢ KA5020 [13]		 JC243  JC261  JD171  JD282  JD602  JE160  JE689  HL457  HL460  JJ140  JJ184  JJ501
HBS024 Ⓞ (22-39002B) M11x1.50x95mm (x12)	JD327 ⓈⓈ (31-026472-00) JD171 ⓈⓈ 31-027048-00 JC152 Ⓢ (x5) 31-026555-00 Ⓞ JE689 (31-024039-00)	HL460 Ⓢ (Cork) →Ch.8A-L-200 000 HM5277 Ⓢ 24-26864-00/0 (Rubber) →Ch.8A-L-200 000	JJ184 (31-023856-10)	HR615 Ⓢ 24-30667-05/0	NA5001 32x47x10mm, FPM (50-303185-50) NB716 Ⓢ 35x48x10mm, FPM (50-306067-50) NA5133 Ⓢ 85x105x11mm, FPM (24-30727-87/0)			 JD602  JE160  JE689  HL457  HL460  JJ140  JJ184  JJ501
HBS269 Ⓞ (22-33032B) M11x1.50x141.5mm (x12)	JD602 Ⓢ (31-026277-00) JD282 Ⓢ (x5) (31-026880-00)	HL730 Ⓢ 24-27424-00/0	JJ501 (31-027042-00)		NA5001 32x47x10mm, FPM (50-303185-50) NB716 Ⓢ 35x48x10mm, FPM (50-306067-50) NA5133 Ⓢ 85x105x11mm, FPM (24-30727-87/0)			 HL457  HL460  JJ140  JJ184  JJ501
HBS024 Ⓞ (22-39002B) M11x1.50x95mm (x12)	JC261 Ⓢ (31-026898-00) JC152 Ⓢ (x5) 31-026555-00	HL460 Ⓢ (Cork) HM5277 Ⓢ 24-26864-00/0 (Rubber)	JJ184 (31-023856-10)	HR615 Ⓢ 24-30667-05/0	NA5001 32x47x10mm, FPM (50-303185-50) NB716 Ⓢ 35x48x10mm, FPM (50-306067-50) NA5133 Ⓢ 85x105x11mm, FPM (24-30727-87/0)			 JJ140  JJ184  JJ501
HBS024 Ⓞ (22-39002B) M11x1.50x95mm (x12)	JD327 ⓈⓈ (31-026472-00) JD171 ⓈⓈ 31-027048-00 JC152 Ⓢ (x5) 31-026555-00 Ⓞ JE689 (31-024039-00)	JN438 (50-026864-00) (Rubber) HM5277 Ⓢ 24-26864-00/0 (Rubber) →Ch.8A-L-200 000	JJ184 (31-023856-10)	HR615 Ⓢ 24-30667-05/0	NA5001 32x47x10mm, FPM (50-303185-50) NB716 Ⓢ 35x48x10mm, FPM (50-306067-50) NA5133 Ⓢ 85x105x11mm, FPM (24-30727-87/0)			 JJ140  JJ184  JJ501











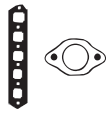

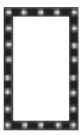

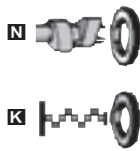

AUDI



KW/PS



100 1.8L 08/83 → 07/89 28					BM360 (Fibre) 30-026807-30	DM360 21-26807-24/0	EG873
100 1.8L quattro 10/84 → 07/90							
100 Avant 1.8L 08/83 → 07/90							
100 Avant 1.8L quattro 10/84 → 07/90							
SH	1781	4	81.00		65/88		
DS/JW/NP	1781	4	81.00		66/89		
100 1.8L 08/82 → 12/87 29					BM360 (Fibre) 30-026807-30	DM360 21-26807-24/0 DR DM361 [83] 21-26807-22/0 RS	EG873
100 Avant 1.8L 08/82 → 12/87							
DR/RS	1781	4	81.00				
100 1.8L CAT 03/85 → 11/90 30					BM360 (Fibre) 30-026807-30	DM360 21-26807-24/0 4B DM361 [83] 21-26807-22/0 PH	EG873
100 1.8L quattro 08/85 → 11/90							
100 Avant 1.8L 03/85 → 11/90							
100 Avant 1.8L quattro 08/85 → 10/90							
4B	1781	4	81.00	SPi	66/89		
PH	1781	4	81.00		66/89		
100 2.0L 08/84 → 12/87 31					BM840 (Fibre) 30-026326-10	DM840 (21-26326-22/0)	EX995 (22-23856-06/0)
100 Avant 2.0L 09/86 → 11/87							
100 Avant 2.0L E 01/85 → 12/87							
SL	1994	5	81.00		83/113		
KP	1994	5	81.00		85/116		











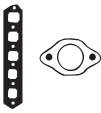

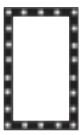

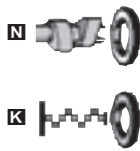

























































								 BM360
HBS043 Ⓞ (22-39001B) M11x1.50x95mm (x10)	JC478 ■ 31-026397-00 PA459 ■ 50-024870-00 (NBR) JC152 ■ (x4) 31-026555-00 Ⓞ JE904 (31-023715-00)	HL457 ■ [79] 24-25753-01/0 (Cork) HM5053 ■ [80] 24-28543-00/0 (ACM)	JJ140 (31-026554-10)	HR569 ■ 24-30667-00/0	NA5001 32x47x10mm, FPM (50-303185-50) NA5001 ■ 32x47x10mm, FPM (50-303185-50) NA5133 ■ 85x105x11mm, FPM (24-30727-87/0)	HL5020 [245]■ KA5020 [13]		 BM840
HBS043 Ⓞ (22-39001B) M11x1.50x95mm (x10)	JC478 ■ 31-026397-00 DR PA459 ■ 50-024870-00 (NBR) DR JC152 ■ (x4) 31-026555-00 Ⓞ JE138 (31-024515-00) RS Ⓞ JE904 (31-023715-00) DR	HL457 ■ [79] 24-25753-01/0 (Cork) HM5053 ■ [80] 24-28543-00/0 (ACM)	JJ140 (31-026554-10)	HR569 ■ 24-30667-00/0	NA5001 32x47x10mm, FPM (50-303185-50) NA5001 ■ 32x47x10mm, FPM (50-303185-50) NA5133 ■ 85x105x11mm, FPM (24-30727-87/0)	HL5020 [245]■ KA5020 [13]		 JC152
HBS043 Ⓞ (22-39001B) M11x1.50x95mm (x10)	JC478 ■ 31-026397-00 4B PA459 ■ 50-024870-00 (NBR) 4B JC152 ■ (x4) 31-026555-00 Ⓞ JE138 (31-024515-00) PH Ⓞ JE904 (31-023715-00) 4B	HL457 ■ [79] 24-25753-01/0 (Cork) HM5053 ■ [80] 24-28543-00/0 (ACM)	JJ140 (31-026554-10)	HR569 ■ 24-30667-00/0	NA5001 32x47x10mm, FPM (50-303185-50) NA5001 ■ 32x47x10mm, FPM (50-303185-50) NA5133 ■ 85x105x11mm, FPM (24-30727-87/0)	HL5020 [245]■ KA5020 [13]		 JC261
HBS024 Ⓞ (22-39002B) M11x1.50x95mm (x12)	JC261 ■ (31-026898-00) JC152 ■ (x5) 31-026555-00	JN438 (50-026864-00) (Rubber) HL460 ■ (Cork) HM5277 ■ 24-26864-00/0 (Rubber)	JJ184 (31-023856-10)	HR615 ■ 24-30667-05/0	NA5001 32x47x10mm, FPM (50-303185-50) NB716 ■ 35x48x10mm, FPM (50-306067-50) NA5133 ■ 85x105x11mm, FPM (24-30727-87/0)			 JC478
								 JE904
								 PA459
								 HL457
								 HL460
								 JJ140
								 JJ184



KW/PS



100 2.0L 12/90 → 06/94 32				BT810 (Fibre) 30-027257-20		DT814 21-26470-20/0 → Ch.4A-P-160 000 DT815 21-27257-23/0 Ch.4A-P-160 001 →		ES471 → 07/92	
100 Avant 2.0L E 09/91 → 06/94									
AAE	1984	4	82.50	Monomotronic	74/100				
100 2.0L CAT 01/88 → 11/90 33				BM840 (Fibre) 30-026326-10				EX995 (22-23856-06/0)	
100 Avant 2.0L E CAT 01/88 → 11/90									
RT	1994	5	81.00	KE-Jetronic	85/116				
100 2.0L D Diesel 08/82 → 07/88 34				BT470 (Fibre), 1.61mm, 3 Holes (30-026267-10) 08/85 → Ch.44-G-000 001 →		DL491▲ (21-26535-40/0)		EX995 (22-23856-06/0)	
100 Avant 2.0L D Diesel 03/83 → 11/90									
CN	1986	5	76.50		51/69				
100 2.0L D Turbo Diesel 08/82 → 02/88 35				BT470 (Fibre), 1.61mm, 3 Holes (30-026267-10) 08/85 → Ch.44-G-000 001 →		DL491▲ (21-26535-40/0)		EX995 (22-23856-06/0)	
100 Avant 2.0L TD Diesel 03/83 → 10/87									
DE	1986	5	76.50		64/87				
100 2.0L D Turbo Diesel 03/88 → 11/90 36				BT470 (Fibre), 1.61mm, 3 Holes (30-026267-10)		DL491▲ (21-26535-40/0)		EW860 (22-23856-07/0)	
100 Avant 2.0L TD Diesel 03/88 → 11/90									
NC	1986	5	76.50	SOHC	74/100				
100 2.0L E 12/90 → 06/94 37				BT810 (Fibre) 30-027257-20		DT814 21-26470-20/0 → Ch.8 B-P-006 500 DT815 21-27257-23/0 Ch.8 B-P-006 501 →		EB970 22-27500-01/0 ABK ES471 AAD	
100 Avant 2.0L E 09/91 → 06/94									
AAD	1984	4	82.50	K-Motronic	85/116				
ABK	1984	4	82.50	Digifant	85/116				











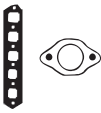

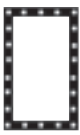

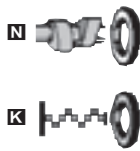







								
HBS043 Ⓢ [22-39001B] M11x1.50x95mm (x10)	JD482 ■ (31-027351-00) PA459 ■ 50-024870-00 (NBR) JC152 ■ (x4) 31-026555-00 JD606 ■ (31-028918-00)  JE689 (31-024039-00)	JP024 50-027505-00 Ch.4A-P-160 001→ HL457 ■ [79] 24-25753-01/0 (Cork) →Ch.4A-P-160 000 HM5053 ■ [80] 24-28543-00/0 (ACM) →Ch.4A-P-160 000	JJ140 (31-026554-10) →07/92	HR569 ■ 24-30667-00/0	NA5001 32x47x10mm, FPM (50-303185-50) NA5001 ■ 32x47x10mm, FPM (50-303185-50) NA5133 ■ 85x105x11mm, FPM (24-30727-87/0)	HL5020 [245]■	 BM840  BT470  BT810  JC152  JC261  JD171  JD482  JD483  JD606  JE689  PA459  HL457  HL460  HL462  HL463  JP024  JJ140  JJ184	
HBS024 Ⓢ [22-39002B] M11x1.50x95mm (x12)	JD171 ■ 31-027048-00 JD327 ■ ■ (31-026472-00) JC152 ■ (x5) 31-026555-00	JN438 (50-026864-00) (Rubber) HL460 ■ (Cork) HM5277 ■ 24-26864-00/0 (Rubber)	JJ184 (31-023856-10)	HR615 ■ 24-30667-05/0	NA5001 32x47x10mm, FPM (50-303185-50) NB716 ■ 35x48x10mm, FPM (50-306067-50) NA5133 ■ 85x105x11mm, FPM (24-30727-87/0)		 JD482  JD483  JD606  JE689  PA459  HL457  HL460  HL462  HL463  JP024  JJ140  JJ184	
HBS021 Ⓢ [22-39003B] M12x1.75x115mm (x12)	JC152 ■ (x5) 31-026555-00	HL462 ■ (24-24069-00/0) →08/81 →Ch.43-B-077 978 HL463 ■ 24-26535-00/0 09/81→ Ch.43-B-077 979→	JJ184 (31-023856-10)	HR615 ■ 24-30667-05/0	NA5001 32x47x10mm, FPM (50-303185-50) NB716 ■ 35x48x10mm, FPM (50-306067-50) NA5133 ■ 85x105x11mm, FPM (24-30727-87/0)	NA5278 [54]	 JE689  PA459  HL457  HL460  HL462  HL463  JP024  JJ140  JJ184	
HBS021 Ⓢ [22-39003B] M12x1.75x115mm (x12)	JC261 ■ (31-026898-00) JC152 ■ (x5) 31-026555-00	HL463 ■ 24-26535-00/0	JJ184 (31-023856-10)	HR615 ■ 24-30667-05/0	NA5001 32x47x10mm, FPM (50-303185-50) NB716 ■ 35x48x10mm, FPM (50-306067-50) NA5133 ■ 85x105x11mm, FPM (24-30727-87/0)	NA5278 [54]	 HL463  JP024  JJ140  JJ184	
HBS021 Ⓢ [22-39003B] M12x1.75x115mm (x12)	JC261 ■ (31-026898-00) JC152 ■ (x5) 31-026555-00	HL463 ■ 24-26535-00/0	JJ184 (31-023856-10)	HR615 ■ 24-30667-05/0	NA5001 32x47x10mm, FPM (50-303185-50) NB716 ■ 35x48x10mm, FPM (50-306067-50) NA5133 ■ 85x105x11mm, FPM (24-30727-87/0)	NA5278 [54]	 HL463  JP024  JJ140  JJ184	
HBS043 Ⓢ [22-39001B] M11x1.50x95mm (x10)	JD482 ■ (31-027351-00) JD483 ■ (31-027352-00) JC152 ■ (x4) 31-026555-00 JD606 ■ (31-028918-00)  JE689 (31-024039-00)	JP024 50-027505-00 ABK HL457 ■ [79] 24-25753-01/0 (Cork) AAD HM5053 ■ [80] 24-28543-00/0 (ACM) AAD	JJ140 (31-026554-10)	HR569 ■ 24-30667-00/0	NA5001 32x47x10mm, FPM (50-303185-50) NA5001 ■ 32x47x10mm, FPM (50-303185-50) NA5133 ■ 85x105x11mm, FPM (24-30727-87/0)	HL5020 [245]■	 BM840  BT470  BT810  JC152  JC261  JD171  JD482  JD483  JD606  JE689  PA459  HL457  HL460  HL462  HL463  JP024  JJ140  JJ184	



KW/PS

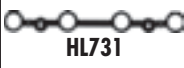

100 2.0L E 16V		01/92 → 06/94		38		BY750 (MLS)		DY751	
100 2.0L E 16V quattro		07/92 → 06/94				30-027930-00		21-27930-24/0 → Eng. ACE 017 542	
ACE	1984	4	82.50	KE-Motronic	103/140			DY752 21-27930-25/0 Eng. ACE 017 543 →	
100 2.2L		08/84 → 11/90		39		BM840 (Fibre)		DM840	
100 2.2L E quattro		08/85 → 07/86				30-026326-10		(21-26326-22/0)	
100 2.2L quattro		08/84 → 11/90						EX995	
100 Avant 2.2L		08/84 → 11/90						(22-23856-06/0)	
100 Avant 2.2L E quattro		08/85 → 07/86							
100 Avant 2.2L quattro		08/84 → 11/90							
KZ	2226	5	81.00		85/116				
PX	2226	5	81.00	SOHC	88/120				
HX	2226	5	81.00	SOHC	100/136				
KU	2226	5	81.00	K-Jetronic, SOHC	101- 103/ 137- 140				
100 2.2L E Turbo quattro		08/86 → 11/90		40		BM840 (Fibre)		DM940▲	
100 2.2L Turbo		08/86 → 11/90				30-026326-10		(21-24949-21/0)	
100 Avant 2.2L Turbo		08/86 → 11/90						EX995	
100 Avant 2.2L Turbo quattro		08/86 → 11/90						(22-23856-06/0)	
MC	2226	5	81.00		121/165				
100 2.2L S4 Turbo quattro		08/91 → 06/94		41		AY960 (MLS)		CY960	
100 Avant 2.2L S4 Turbo quattro		09/91 → 06/94				30-028016-00		21-28016-20/0	
AAN	2226	5	81.00		169/230			ECO10 (22-26274-00/0)	
100 2.3L		03/90 → 11/90		42		BT820 (Fibre)		DT820	
100 2.3L E		01/90 → 06/94						21-26082-21/0	
100 2.3L E quattro		12/90 → 06/94						EX995	
100 2.3L quattro		01/90 → 11/90						(22-23856-06/0)	
100 Avant 2.3L E		09/91 → 06/94							
100 Avant 2.3L E quattro		09/91 → 06/94							
AAR	2309	5	82.50		98/133				
100 2.3L E		10/86 → 11/90		43		BT820 (Fibre)		EX995	
100 2.3L E quattro		08/86 → 11/90						(22-23856-06/0)	
100 Avant 2.3L		08/86 → 11/90							
100 Avant 2.3L E quattro		08/86 → 11/90							
NF	2309	5	82.50	K-Jetronic	100/136				

								
HBS028 Ⓞ (22-39004B) M11x1.50x147mm (x10)	JD281 ■ (31-027904-00) JD282 ■ (x4) (31-026880-00) Ⓞ JE689 (31-024039-00)	HL606 ■ 24-26237-01/0 →Eng.ACE 017 542 HL731 ■ 24-27937-00/0 Eng.ACE 017 543→	JJ140 (31-026554-10)	HR816 ■ (x2) 24-30667-05/0	NA5001 32x47x10mm, FPM (50-303185-50) NA5001 ■ 32x47x10mm, FPM (50-303185-50) NA5133 ■ 85x105x11mm, FPM (24-30727-87/0)	HL5020 [245]■		
HBS024 Ⓞ (22-39002B) M11x1.50x95mm (x12)	JC261 ■ (31-026898-00) JC152 ■ (x5) 31-026555-00 Ⓞ JE689 (31-024039-00)	HL460 ■ (Cork) HM5277 ■ 24-26864-00/0 (Rubber)	JJ184 (31-023856-10)	HR615 ■ 24-30667-05/0	NA5001 32x47x10mm, FPM (50-303185-50) NB716 ■ 35x48x10mm, FPM (50-306067-50) NA5133 ■ 85x105x11mm, FPM (24-30727-87/0)			
HBS024 Ⓞ (22-39002B) M11x1.50x95mm (x12)	JC152 ■ (x5) 31-026555-00	HL460 ■ (Cork) HM5277 ■ 24-26864-00/0 (Rubber)	JJ184 (31-023856-10)	HR615 ■ 24-30667-05/0	NA5001 32x47x10mm, FPM (50-303185-50) NB716 ■ 35x48x10mm, FPM (50-306067-50) NA5133 ■ 85x105x11mm, FPM (24-30727-87/0)			
HBS269 Ⓞ (22-33032B) M11x1.50x141.5mm (x12)	JD602 ■ (31-026277-00) JD603 ■ (31-027514-00)	HL730 ■ 24-27424-00/0	JJ501 (31-027042-00)		NA5001 32x47x10mm, FPM (50-303185-50) NB716 ■ 35x48x10mm, FPM (50-306067-50) NA5133 ■ 85x105x11mm, FPM (24-30727-87/0)			
HBS024 Ⓞ (22-39002B) M11x1.50x95mm (x12)	JD327 ■ ■ (31-026472-00) JD171 ■ ■ 31-027048-00 JC152 ■ (x5) 31-026555-00 Ⓞ JE689 (31-024039-00)		JJ184 (31-023856-10)	HR615 ■ 24-30667-05/0	NA5001 32x47x10mm, FPM (50-303185-50) NB716 ■ 35x48x10mm, FPM (50-306067-50) NA5133 ■ 85x105x11mm, FPM (24-30727-87/0)			
HBS024 Ⓞ (22-39002B) M11x1.50x95mm (x12)	JD327 ■ ■ (31-026472-00) JD171 ■ ■ 31-027048-00 JC152 ■ (x5) 31-026555-00 Ⓞ JE689 (31-024039-00)	JN438 (50-026864-00) (Rubber) HM5277 ■ 24-26864-00/0 (Rubber) →Ch.44-L-072 000	JJ184 (31-023856-10)	HR615 ■ 24-30667-05/0	NA5001 32x47x10mm, FPM (50-303185-50) NB716 ■ 35x48x10mm, FPM (50-306067-50) NA5133 ■ 85x105x11mm, FPM (24-30727-87/0)			
								
								
								
								
								
								
								
								
								





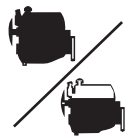

AUDI

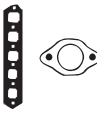

KW/PS



100 2.4L D Diesel		08/89 → 06/94		44		AF5340 (MLS), 1,53mm, 1 Hole 30-027550-20 AF5350 (MLS), 1,57mm, 2 Holes 30-027551-20 AF5360 (MLS), 1,61mm, 3 Holes 30-027552-20	DW830▲ 21-27046-20/0	EB960 (22-26125-00/0)
100 Avant 2.4L D Diesel		08/89 → 06/94						
3D/AAS	2370	5	79.50		60/81			
100 2.5L TDI Diesel		01/90 → 07/94		45		AF5310 (MLS), 1,51mm, 1 Hole 30-027510-40 AF5320 (MLS), 1,57mm, 2 Holes 30-027511-40 AF5330 (MLS), 1,61mm, 3 Holes 30-027512-40	DW860▲ 21-27504-20/0	EW860 (22-23856-07/0)
100 Avant 2.5L TDI Diesel		01/90 → 06/94						
AAT/ABP	2461	5	81.00		85/116			
1T	2461	5	81.00		88/120			
100 2.6L		03/92 → 06/94		46		AY060 (Fibre), 2.00mm (x2) 30-027222-20	DT660 21-27222-20/0	
100 2.6L quattro		04/92 → 06/94						
100 Avant 2.6L		03/92 → 06/94						
100 Avant 2.6L quattro		07/92 → 06/94						
ACZ	2598	6	82.50	SOHC, V6	102/139			
ABC	2598	6	82.50	Injection, V6	110/150			
100 2.8L E		12/90 → 06/94		47		AY060 (Fibre), 2.00mm (x2) 30-027222-20	DT660 21-27222-20/0	
100 2.8L E quattro		12/90 → 06/94						
100 Avant 2.8L E		09/91 → 06/94						
100 Avant 2.8L E quattro		09/91 → 06/94						
AAH	2771	6	82.50	MH-Motronic, V6	128/174			
200 2.1L 5 E		10/79 → 07/84		48		BD620 (Fibre) 30-024697-10	DD620 → Eng.WC 139 411 DD621 (21-24697-25/0) Eng.WC 139 412 →	EX995 (22-23856-06/0)
WC		2144 5 79.50		100/136				
200 2.1L Turbo		08/83 → 01/88		49		BD620 (Fibre) 30-024697-10	DD622	EX995 (22-23856-06/0)
200 2.1L Turbo quattro		08/83 → 09/86						
200 Avant 2.1L Turbo quattro		09/83 → 01/88						
KG	2144	5	79.50		134/182			
200 2.2L 20V Turbo quattro		03/89 → 12/90		50		AY960 (MLS) 30-028016-00	CY960 21-28016-20/0	EC010 (22-26274-00/0)
200 Avant 2.2L 20V Turbo quattro		07/89 → 12/90						
3B	2226	5	81.00		162/220			
200 2.2L Turbo		08/85 → 09/91		51		BM840 (Fibre) 30-026326-10	DM840 (21-26326-22/0)	EX995 (22-23856-06/0)
200 2.2L Turbo quattro		01/85 → 12/91						
200 Avant 2.2L Turbo		08/85 → 09/91						
200 Avant 2.2L Turbo quattro		09/83 → 12/91						
MC	2226	5	81.00		121/165			
2B	2226	5	81.00		140/190			
1B	2226	5	81.00		147/200			

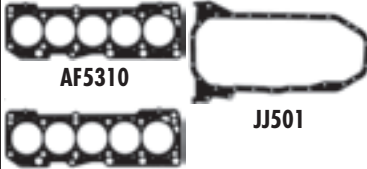









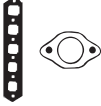

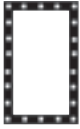

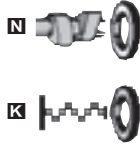











































































								
HBS021 Ⓢ (22-39003B) M12x1.75x115mm (x12)	JD312 ■ 31-027043-00 JC152 ■ (x5) 31-026555-00 Ⓢ JE138 (31-024515-00) Ⓢ JE689 (31-024039-00)	JN915 50-027046-00		HR615 ■ 24-30667-05/0	NA5001 32x47x10mm, FPM (50-303185-50) NB716 ■ 35x48x10mm, FPM (50-306067-50) NA5133 ■ 85x105x11mm, FPM (24-30727-87/0)	NA5278 [54]		AF5310 AF5320 AF5330 AF5340 AF5350 AF5360
HBS021 Ⓢ (22-39003B) M12x1.75x115mm (x12)	JD312 ■ 31-027043-00 JC152 ■ (x5) 31-026555-00	JN967 50-027504-00	JJ184 (31-023856-10)	HR615 ■ 24-30667-05/0	NA5001 (x2) 32x47x10mm, FPM (50-303185-50) NB716 ■ 35x48x10mm, FPM (50-306067-50) NA5133 ■ 85x105x11mm, FPM (24-30727-87/0)	NB567 [2]■		AY060 AY960 BD620
HBS064 Ⓢ (22-39010B) M11x1.50x137mm (x16)		JM5166 (x2) 50-027936-00 (ACM)		HR569 ■ (x2) 24-30667-00/0	NA5001 (x3) 32x47x10mm, FPM (50-303185-50) NB716 ■ 35x48x10mm, FPM (50-306067-50) NA5133 ■ 85x105x11mm, FPM (24-30727-87/0)			BM840 JC152 JC261 JD312 JD602 JE689
HBS064 Ⓢ (22-39010B) M11x1.50x137mm (x16)		JM5166 (x2) 50-027936-00 (ACM)		HR569 ■ (x2) 24-30667-00/0	NA5001 (x3) 32x47x10mm, FPM (50-303185-50) NB716 ■ 35x48x10mm, FPM (50-306067-50) NA5133 ■ 85x105x11mm, FPM (24-30727-87/0)			HL460 JN915 JN967 JJ184
HBS024 Ⓢ (22-39002B) M11x1.50x95mm (x12) Eng.WC 139 412 →	JC261 ■ (31-026898-00) Eng.WC 139 412 → JC152 ■ (x5) 31-026555-00 Ⓢ JE689 (31-024039-00)	HL460 ■ (Cork) Eng.WC 139 412 → HMS277 ■ 24-26864-00/0 (Rubber) Eng.WC 139 412 →	JJ184 (31-023856-10)	HR615 ■ 24-30667-05/0	NA5001 32x47x10mm, FPM (50-303185-50) NB716 ■ 35x48x10mm, FPM (50-306067-50) NA5133 ■ 85x105x11mm, FPM (24-30727-87/0)			HL460 JN915 JN967 JJ184
HBS024 Ⓢ (22-39002B) M11x1.50x95mm (x12)	JC261 ■ (31-026898-00) JC152 ■ (x5) 31-026555-00	JN438 (50-026864-00) (Rubber) HL460 ■ (Cork) HMS277 ■ 24-26864-00/0 (Rubber)	JJ184 (31-023856-10)	HR615 ■ 24-30667-05/0	NA5001 32x47x10mm, FPM (50-303185-50) NB716 ■ 35x48x10mm, FPM (50-306067-50) NA5133 ■ 85x105x11mm, FPM (24-30727-87/0)			
HBS269 Ⓢ (22-33032B) M11x1.50x141.5mm (x12)	JD602 ■ (31-026277-00) JD603 ■ (31-027514-00)	HL730 ■ 24-27424-00/0	JJ501 (31-027042-00)		NA5001 32x47x10mm, FPM (50-303185-50) NB716 ■ 35x48x10mm, FPM (50-306067-50) NA5133 ■ 85x105x11mm, FPM (24-30727-87/0)			
HBS024 Ⓢ (22-39002B) M11x1.50x95mm (x12)	JC261 ■ (31-026898-00) JC152 ■ (x5) 31-026555-00	HL460 ■ (Cork) HMS277 ■ 24-26864-00/0 (Rubber)	JJ184 (31-023856-10)	HR615 ■ 24-30667-05/0	NA5001 32x47x10mm, FPM (50-303185-50) NB716 ■ 35x48x10mm, FPM (50-306067-50) NA5133 ■ 85x105x11mm, FPM (24-30727-87/0)			



KW/PS

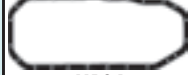

200 2.3L 11/86 → 09/91 52						BT820 (Fibre)	DT820	EX995
200 Avant 2.3L 11/86 → 09/91							21-26082-21/0	(22-23856-06/0)
NF	2309	5	82.50	K-Jetronic	100/136			
A2 1.2L TDI Diesel 03/01 → 08/05 53						AC5190 (MLS), 1.45mm, 1 Hole	CC5190▲☒	ED5650 [8]
ANY	1191	3	76.50	Direct Injection, SOHC	45/61	30-029459-00	(21-29459-20/0)	(22-29671-00/0)
						AC5200 (MLS), 1.53mm, 2 Holes 30-029460-00		
						AC5210 (MLS), 1.61mm, 3 Holes (30-029461-00)		
A2 1.4L 02/00 → 08/05 54						AB5701 (MLS)	CB5700☒	EB5700 [8]
AUA	1390	4	76.50	MPI, SOHC	55/75	30-029313-10	21-29313-20/0	22-29313-00/0
BBY	1390	4	76.50		55/75			
A2 1.4L TDI Diesel 02/00 → 08/05 55						AD5650 (MLS), 1.45mm, 1 Hole	CD5650▲	ED5650 [8]
AMF/BHC	1422	3	79.50	Direct Injection, SOHC	55/75	30-029663-00	21-29671-20/0	(22-29671-00/0)
ATL	1422	3	79.50		66/89	AD5660 (MLS), 1.53mm, 2 Holes 30-029664-00		
						AD5670 (MLS), 1.61mm, 3 Holes 30-029665-00		
A2 1.6L FSI 05/02 → 08/05 56						AC5280 (MLS)		
BAD	1598	4	76.50		81/110	30-029466-00		
A3 1.6L 08/00 → 57						AC5220 (MLS)	CC5222	EC5220 [8]
AVU/BFQ	1595	4	81.00	SOHC	75/102	30-029462-00	21-29462-22/0	(22-29462-00/0)
A3 1.6L 05/03 → 58						AC5220 (MLS)	CC5222	EC5220 [8]
BGU	1595	4	81.00	SOHC	75/102	30-029462-00	21-29462-22/0	(22-29462-00/0)
BSE/BSF	1595	4	81.00	Injection, SOHC	75/102			
A3 1.6L 09/96 → 08/00 59						AC5220 (MLS)	CC5221	EC080 [8]
AEH	1595	4	81.00	Motronic	74/100	30-029462-00	21-29462-21/0	(22-28897-01/0)
AKL	1595	4	81.00		74/100	APF	APF	AEH, AKL
APF	1595	4	81.00	SOHC	74/100	AY980 (MLS) 30-028925-00	CY980 21-28925-20/0	EC5220 [8] (22-29462-00/0)
						AEH, AKL	AEH, AKL	APF

								
HBS024 Ⓞ (22-39002B) M11x1.50x95mm (x12)	JD327  (31-026472-00) JD171  31-027048-00 JC152  (x5) 31-026555-00  JE689 (31-024039-00)	JN438 (50-026864-00) (Rubber) →Ch.44-L-072 000 HL460  (Cork) →Ch.44 L 072 000 HM5277  24-26864-00/0 (Rubber) →Ch.44-L-072 000	JJ184 (31-023856-10)	HR615  24-30667-05/0	NA5001  32x47x10mm, FPM (50-303185-50) NB716  35x48x10mm, FPM (50-306067-50) NA5133  85x105x11mm, FPM (24-30727-87/0)		 AC5190, AC5200, AC5210  AC5220  AC5280  AD5650, AD5660, AD5670	
HBS311  (22-33035B) M12x1.75x115mm (x8)	JD5278  (31-029671-00) JE5036  (31-029817-00) (MLS)	JM7032 50-030224-00	HR397 [57] 34-000410-00	HR5068  (24-30653-84/0)	NA5001  32x47x10mm, FPM (50-303185-50) NA5124  32x47x10mm, PTFE (50-319433-00) NA5106  35x48x10mm, PTFE (50-319430-00) LK5003  [3] 85x131x15.7mm, PTFE (50-319434-00)	HL5034 [245] 	 AY980  BT820  JC152	
HBS249  (22-33025B) M9x1.25x138mm (x10)	JD5228  (x4) (50-029071-00) JD5298  (31-029825-00)		HR397 [57] 34-000410-00	HR791  24-30614-76/0	NA5180 (x2) 27x42x8mm, FPM (50-319484-00) NA5185  32x42x6mm, FPM (50-319489-00)	KA5025 [13] KK5551 [81]	 JD171  JD5228	
HBS264  (22-33026B) M12x1.75x166mm (x8)	JD5278  (31-029671-00) JD5279  (31-029710-00)	JM7032 50-030224-00	HR397 [57] 34-000410-00	HR5068  (24-30653-84/0)	NA5124  32x47x10mm, PTFE (50-319433-00) NA5106  35x48x10mm, PTFE (50-319430-00) LK5003  [3] 85x131x15.7mm, PTFE (50-319434-00)	HL5034 [245] 	 JD5278  JD5279	
HBS316  (22-33036B) M9x1.25x97mm (x10)	JD5809  31-030229-00 JD5298  (31-029825-00)	HR397 [57] 34-000410-00	HR397 [57] 34-000410-00	HR791  24-30614-76/0	NA5180  27x42x8mm, FPM (50-319484-00) NA5185  32x42x6mm, FPM (50-319489-00)		 JD5293  JD5298	
HBS246  (22-33024B) M10x1.50x120mm (x10)	JD5340  (x4) (50-029939-00) JD5293  (31-029816-00)	JM5205 50-029938-00 (Rubber)	HR397 [57] 34-000410-00	HR817  24-30614-78/0	NA5124  32x47x10mm, PTFE (50-319433-00) NA5106  35x48x10mm, PTFE (50-319430-00) LK5008  [3] 85x131x15.7mm, PTFE (50-319472-00)	HL5034 [245] 	 JD600  JD607	
HBS246  (22-33024B) M10x1.50x120mm (x10)	JD5340  (x4) (50-029939-00) JD5293  (31-029816-00)	JM5205 50-029938-00 (Rubber)	HR397 [57] 34-000410-00	HR817  24-30614-78/0	NA5124  32x47x10mm, PTFE (50-319433-00) NA5106  35x48x10mm, PTFE (50-319430-00)	HL5034 [245] 	 JE5036	
HBS246  (22-33024B) M10x1.50x120mm (x10)	JD5340  (x4) (50-029939-00) APF JD607  50-028924-00 AEH, AKL JD5293  (31-029816-00) APF JD600  31-028454-00 AEH, AKL  JF211 (31-028926-00) AEH	JP024 50-027505-00	JH5117 (50-030046-00)	HR816  24-30653-85/0	NA5124  32x47x10mm, PTFE (50-319433-00) NA5106  35x48x10mm, PTFE (50-319430-00) LK5008  [3] 85x131x15.7mm, PTFE (50-319472-00)	HL5034 [245] 	 JE689  HL460  JP024  JJ184	









AUDI

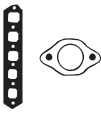

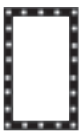
KW/PS

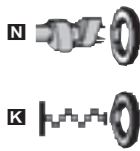

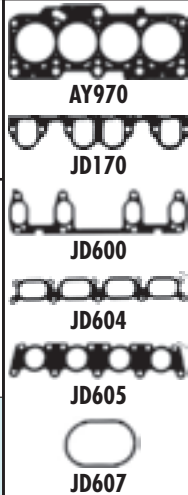
A3 1.6L FSI					08/03 →	60	AG8850 (MLS)	CG8850	
BAG	1598	4	76.50	Injection		85/115	(30-030218-00)	21-30218-00/0	
BLF	1598	4	76.50	Injection, DOHC		85/115			
BLP	1598	4	76.50	Injection		85/116			
A3 1.8L quattro					08/98 →	61	AY970 (MLS)	CY971	
AGN	1781	4	81.00	Injection, DOHC		92/125	30-028495-00	21-28495-21/0 →Ch.8L-V-200 000	EY841 22-28897-02/0
A3 1.8L S3 quattro					03/99 →	62	AY970 (MLS)	CY971	
A3 1.8L T					12/96 →		30-028495-00	21-28495-21/0	EY841 22-28897-02/0
A3 1.8L T quattro					12/96 →				
AGU	1781	4	81.00	Injection, DOHC		110/150			
AQA	1781	4	81.00			110/150			
ARX	1781	4	81.00	DOHC		110/150			
ARZ	1781	4	81.00	SOHC		110/150			
AUM	1781	4	81.00	DOHC		110/150			
AJQ/APP/ARY/AUQ	1781	4	81.00	DOHC		132/180			
AMK	1781	4	81.00	MPi, DOHC		154/210			
APY	1781	4	81.00	DOHC		154/210			
AUL	1781	4	81.00	Injection, DOHC		154/210			
BAM	1781	4	81.00	DOHC		165/224			
A3 1.9L TDI Diesel					08/00 →	63	AF5381 (MLS), 1,49mm, 1 Hole	CC5230▲	
A3 1.9L TDI quattro Diesel					08/00 →		30-030098-10	21-29463-21/0	
ATD	1896	4	79.50			74/100	AF5391 (MLS), 1,57mm, 2 Holes		
AXR	1896	4	79.50	PDi, SOHC		74/100	30-030099-10		
ASZ	1896	4	79.50	PDi, SOHC		96/131	AF5401 (MLS), 1,65mm, 3 Holes		
							30-030100-10		
A3 1.9L TDI Diesel					05/03 →	64	AF5381 (MLS), 1,49mm, 1 Hole	CC5230▲	
BKC	1896	4	79.50			77/105	30-030098-10	21-29463-21/0	
							AF5391 (MLS), 1,57mm, 2 Holes		
							30-030099-10		
							AF5401 (MLS), 1,65mm, 3 Holes		
							30-030100-10		

								
HBS249 Ⓢ (22-33025B) M9x1.25x138mm (x10)	JD5809 ■ 31-030229-00 JD5814E 31-030234-00	HR397 [57] 34-000410-00	HR397 [57] 34-000410-00	HR791 ■ 24-30614-76/0	<input checked="" type="checkbox"/> NA5106E 35x48x10mm, PTFE (50-319430-00) <input checked="" type="checkbox"/> LK5011E [3] [78] 85x131x15.94mm, PTFE →Ch.8P-4-103 000 <input checked="" type="checkbox"/> LK5013E [3] [118] 85x111x15.5mm Ch.8P-4-103 001→			
HBS268 Ⓢ (22-33031B) M10x1.50x120mm (x10) Eng.AGN 107 001→	JD604 ■ (31-028824-00) →Ch.8-LV-200 000 JD607 ■ (x4) 50-028924-00 Ch.8L-W-000 001→ JD605E 31-028826-00  JF205 (31-025070-00)	HL732E 24-28815-00/0	JH5117 (50-030046-00)	HR822E	<input checked="" type="checkbox"/> NA5124 (x2) 32x47x10mm, PTFE (50-319433-00) <input checked="" type="checkbox"/> NA5106E 35x48x10mm, PTFE (50-319430-00) <input checked="" type="checkbox"/> LK5003E [3] 85x131x15.7mm, PTFE (50-319434-00)	HL5040 [245] ■		
HBS268 Ⓢ (22-33031B) M10x1.50x120mm (x10)	JD604 ■ (31-028824-00) JD605E 31-028826-00	HL732E 24-28815-00/0	HR397 [57] 34-000410-00 JH5117 (50-030046-00)	HR822E	<input checked="" type="checkbox"/> NA5124 (x2) 32x47x10mm, PTFE (50-319433-00) <input checked="" type="checkbox"/> NA5106E 35x48x10mm, PTFE (50-319430-00) <input checked="" type="checkbox"/> LK5003E [3] 85x131x15.7mm, PTFE (50-319434-00)	HL5040 [245] ■		
HBS300 Ⓢ (22-33034B) M12x1.75x166mm (x10)	JD170 ■ 31-026556-10 JD600E 31-028454-00	JM5203 50-029934-00	HR397 [57] 34-000410-00	HR816E 24-30653-85/0	<input checked="" type="checkbox"/> NA5124 32x47x10mm, PTFE (50-319433-00) <input checked="" type="checkbox"/> NA5106E 35x48x10mm, PTFE (50-319430-00) <input checked="" type="checkbox"/> LK5003E [3] 85x131x15.7mm, PTFE (50-319434-00)	HL5034 [245] ■		
HBS300 Ⓢ (22-33034B) M12x1.75x166mm (x10)	JD170 ■ 31-026556-10 JD600E 31-028454-00	JM5203 50-029934-00	HR397 [57] 34-000410-00	HR816E 24-30653-85/0	<input checked="" type="checkbox"/> NA5124 32x47x10mm, PTFE (50-319433-00) <input checked="" type="checkbox"/> NA5106E 35x48x10mm, PTFE (50-319430-00) <input checked="" type="checkbox"/> LK5012E [85] 85x132x15.7mm, ACM (50-319535-00)	HL5034 [245] ■		



KW/PS



A3 1.9L TDI Diesel		09/96 → 07/01		65		BZ010 (MLS), 1.45mm, 1 Hole 30-028910-10 →Eng.AGR 151 000 →Eng.ALH 085 000 BZ020 (MLS), 1.53mm, 2 Holes 30-028911-10 →Eng.AGR 151 000 →Eng.ALH 085 000 BZ030 (MLS), 1.61mm, 3 Holes 30-028912-10 →Eng.AGR 151 000 →Eng.ALH 085 000 BZ050 (MLS), 1.57mm, 2 Holes 30-028916-10 Eng.AGR 151 001 → Eng.ALH 085 001 → BZ040 (MLS), 1.47mm, 1 Hole 30-028915-10 Eng.AGR 151 001 → Eng.ALH 085 001 → BZ060 (MLS), 1.67mm, 3 Holes 30-028917-10 Eng.AGR 151 001 → Eng.ALH 085 001 →	DZ010▲☒ 21-26556-20/0	ECO60 [8] 22-28897-00/0
AGR	1896	4	79.50	SOHC	66/89			
ALH	1896	4	79.50		66/89			
A3 1.9L TDI Diesel		08/97 → 07/01		66		BZ010 (MLS), 1.45mm, 1 Hole 30-028910-10 →Eng.AHF 140 000 BZ020 (MLS), 1.53mm, 2 Holes 30-028911-10 →Eng.AHF 140 000 BZ030 (MLS), 1.61mm, 3 Holes 30-028912-10 →Eng.AHF 140 000 BZ040 (MLS), 1.47mm, 1 Hole 30-028915-10 Eng.AHF 140 001 → ASV BZ050 (MLS), 1.57mm, 2 Holes 30-028916-10 Eng.AHF 140 001 → ASV BZ060 (MLS), 1.67mm, 3 Holes 30-028917-10 Eng.AHF 140 001 → ASV	DZ010▲☒ 21-26556-20/0	ECO60 [8] 22-28897-00/0
AHF	1896	4	79.50	SOHC	81/110			
ASV	1896	4	79.50		81/110			
A3 2.0L TDI Diesel		06/05 →		67		AG9630 (MLS), 1.45mm, 1 Hole 30-030349-00 AG9640 (MLS), 1.53mm, 2 Holes AG9650 (MLS), 1.61mm, 3 Holes	EF5380 22-30369-00/0	
A3 2.0L TDI quattro Diesel		01/06 →						
BMM	1968	4	81.00	Direct Injection, DOHC	103/140			
A3 2.0L FSI		05/03 →		68		AG9600 (MLS) 30-030352-00	CG9600 21-30352-00/0 AXW	EG9600 22-30370-00/0
AXW	1984	4	82.50	DOHC	110/150			
BLR/BLX/BLY/BMB/ BVY/BVZ	1984	4	82.50	Injection, DOHC	110/150			

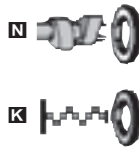
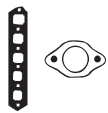

BZ010, BZ020,
BZ030



BZ050, BZ040,
BZ060



JC152



JD170

HBS018Ⓞ
(22-39024B)
M12x1.75x115mm (x10)

JD170■
31-026556-10
JC152■ (x4)
31-026555-00

HR397 [57]
34-000410-00
PA217
16.3x22x2mm

HR816■
24-30653-85/0

■ **NA5001** 32x47x10mm, FPM
(50-303185-50)
■ **NB716**■ 35x48x10mm, FPM
(50-306067-50)
■ **LK5003**■ [3] 85x131x15.7mm, PTFE
(50-319434-00)

NF036 [2]■
NA5278 [54]

HBS018Ⓞ
(22-39024B)
M12x1.75x115mm (x10)

JD170■
31-026556-10
JC152■ (x4)
31-026555-00

HR397 [57]
34-000410-00

HR816■
24-30653-85/0

■ **NA5001** 32x47x10mm, FPM
(50-303185-50)
■ **NB716**■ 35x48x10mm, FPM
(50-306067-50)
■ **LK5003**■ [3] 85x131x15.7mm, PTFE
(50-319434-00)

NA5278 [54]

HBS300Ⓞ
(22-33034B)
M12x1.75x166mm (x10)

JD170■
31-026556-10

HR397 [57]
34-000410-00

HR816■
24-30653-85/0

■ **NA5124** 32x47x10mm, PTFE
(50-319433-00)
■ **NA5106**■ 35x48x10mm, PTFE
(50-319430-00)
■ **LK5012**■ [85] 85x132x15.7mm, ACM
(50-319535-00)

HBS363Ⓞ
(22-33038B)
M10x1.50x122mm (x10)

JD5873■
50-030353-00
(FPM)
JD5813■
31-030233-00

JM7048
50-030354-00
(Rubber/Metal)
AXW

HR397 [57]
34-000410-00

HR791■
24-30614-76/0

■ **NA5124** 32x47x10mm, PTFE
(50-319433-00)
■ **NA5106**■ 35x48x10mm, PTFE
(50-319430-00)
■ **LK5008**■ [3] 85x131x15.7mm, PTFE
(50-319472-00)

Ch.8P-4-158 000 →











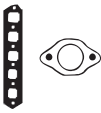

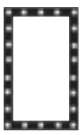

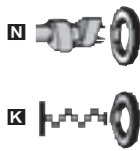



AUDI



KW/PS

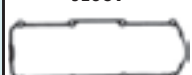

A3 2.0L TDI Diesel 05/03 → 69						AG8970 (MLS), 1.55mm, 1 Hole 30-030249-00 AG8800 (MLS), 1.63mm, 2 Holes (30-030213-00) AG8960 (MLS), 1.71mm, 3 Holes (30-030248-00)	EF5380 22-30369-00/0
A3 2.0L TDI 16V Diesel 05/03 →							
AZV	1968	4	81.00	Direct Injection, DOHC	100/136	AG8970 (MLS), 1.55mm, 1 Hole 30-030249-00 AG8800 (MLS), 1.63mm, 2 Holes (30-030213-00) AG8960 (MLS), 1.71mm, 3 Holes (30-030248-00)	EF5380 22-30369-00/0
BKD	1968	4	81.00	PDi, DOHC	103/140		
A3 2.0L TDI Diesel 03/06 → 70						AG8970 (MLS), 1.55mm, 1 Hole 30-030249-00 AG8800 (MLS), 1.63mm, 2 Holes (30-030213-00) AG8960 (MLS), 1.71mm, 3 Holes (30-030248-00)	EF5380 22-30369-00/0
A3 2.0L TDI quattro Diesel 03/06 →							
BMN	1968	4	81.00	Direct Injection, DOHC	125/170	AG8970 (MLS), 1.55mm, 1 Hole 30-030249-00 AG8800 (MLS), 1.63mm, 2 Holes (30-030213-00) AG8960 (MLS), 1.71mm, 3 Holes (30-030248-00)	EF5380 22-30369-00/0
A3 3.2L V6 quattro 07/03 → 71							
BDB/BMJ	3189	6	84.00	DOHC, V6	184/250	AG9610 (MLS) 30-030350-00	CG9610 21-30350-00/0
BUB	3189	6	84.50	Injection, DOHC, V6	184/250		
A4 1.6L 07/00 → 12/04 72						AC5220 (MLS) 30-029462-00	CC5223 21-29462-00/0
A4 Avant 1.6L 07/00 → 09/01							
ALZ	1595	4	81.00	SOHC	75/102	AC5220 (MLS) 30-029462-00 AHL, ANA, ARM AY940 (MLS) 30-028383-00 ADP	EC5220 [8] (22-29462-00/0)
A4 1.6L 01/95 → 07/00 73							
A4 Avant 1.6L 03/96 → 07/00						CC5220 21-29462-20/0 AHL, ANA, ARM CY942 21-28383-22/0 ADP	EC5220 [8] (22-29462-00/0) AHL, ANA, ARM
ADP	1595	4	81.00	SOHC	74/100		
AHL/ANA/ARM	1595	4	81.00		74/100		
A4 1.8L 04/95 → 11/00 74						AY970 (MLS) 30-028495-00	CY970 21-28495-20/0
A4 1.8L quattro 07/95 → 11/00							
A4 Avant 1.8L 07/95 → 09/01							
A4 Avant 1.8L quattro 07/95 → 09/01							
AFY	1781	4	81.00	DOHC	85/116		EY840 22-28825-00/0

								 AC5220
HBS364 Ⓢ (22-39032B) M12x1.75x149mm (x10)	JD5805 ■ 50-030225-00 JD5806 ■ 31-030226-00 JD5815 ■ 31-030235-00	JM7031 50-030223-00 (Rubber)	HR397 [57] 34-000410-00	HR791 ■ 24-30614-76/0	■ NA5124 (x2) 32x47x10mm, PTFE (50-319433-00) ■ NA5106 ■ 35x48x10mm, PTFE (50-319430-00) ■ LK5012 ■ [85] 85x132x15.7mm, ACM (50-319535-00)	HL5040 [245] ■ KK5522 [86]		 AY940
HBS364 Ⓢ (22-39032B) M12x1.75x149mm (x10)	JD5805 ■ 50-030225-00 JD5806 ■ 31-030226-00		HR397 [57] 34-000410-00	HR791 ■ 24-30614-76/0	■ NA5124 32x47x10mm, PTFE (50-319433-00) ■ NA5106 ■ 35x48x10mm, PTFE (50-319430-00) ■ LK5012 ■ [85] 85x132x15.7mm, ACM (50-319535-00)	KK5522 [86]		 AY970
HBS466 (22-33039B)	JD5874 ■ 50-030351-00 (FPM)	JM7045 50-030133-00 (Rubber)	HR397 [57] 34-000410-00	HR5062 ■ 24-30614-73/0	■ NA5106 ■ 35x48x10mm, PTFE (50-319430-00)			 JC152
HBS246 Ⓢ (22-33024B) M10x1.50x120mm (x10)	JD5341 ■ (x4) (50-029940-00) JC152 ■ (x4) 31-026555-00	JM5205 50-029938-00 (Rubber)	HR397 [57] 34-000410-00	HR817 ■ 24-30614-78/0	■ NA5124 32x47x10mm, PTFE (50-319433-00) ■ NA5106 ■ 35x48x10mm, PTFE (50-319430-00) ■ LK5008 ■ [3] 85x131x15.7mm, PTFE (50-319472-00)	HL5034 [245] ■		 JD5341
HBS043 Ⓢ (22-39001B) M11x1.50x95mm (x10) ADP HBS246 Ⓢ (22-33024B) M10x1.50x120mm (x10) AHL, ANA, ARM	JD5341 ■ (x4) (50-029940-00) AHL, ANA, ARM JC152 ■ (x4) 31-026555-00 JD600 ■ 31-028454-00 ADP JD606 ■ (31-028918-00) AHL, ANA, ARM Ⓢ JE689 (31-024039-00)	JP024 50-027505-00	HR397 [57] 34-000410-00 AHL/ANA/ARM	HR816 ■ 24-30653-85/0	■ NA5001 32x47x10mm, FPM (50-303185-50) ADP ■ NA5124 32x47x10mm, PTFE (50-319433-00) AHL, ANA, ARM ■ NA5106 ■ 35x48x10mm, PTFE (50-319430-00) AHL, ANA, ARM ■ NA5001 ■ 32x47x10mm, FPM (50-303185-50) ADP ■ LK5008 ■ [3] 85x131x15.7mm, PTFE (50-319472-00) AHL, ANA, ARM ■ NA5133 ■ 85x105x11mm, FPM (24-30727-87/0) ADP	HL5020 [245] ■ ADP HL5034 [245] ■ AHL, ANA, ARM		 JD600
HBS171 Ⓢ (22-39027B) M11x1.50x101mm (x10)	JD604 ■ (31-028824-00) JD605 ■ 31-028826-00	HL732 ■ 24-28815-00/0	JJ610 (50-028825-00)	HR822 ■	■ NA5001 (x2) 32x47x10mm, FPM (50-303185-50) ■ NA5001 ■ 32x47x10mm, FPM (50-303185-50) ■ NA5133 ■ 85x105x11mm, FPM (24-30727-87/0) ■ LK5006 ■ [3] 85x131x16mm, PTFE (50-319448-00)	HL5020 [245] ■		 JD604
								 JD605
								 JD606
								 JE689
								 JP024
								 JJ610











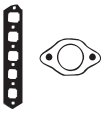

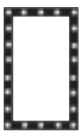

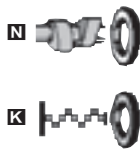













































AUDI



KW/PS



A4 1.8L						01/95 → 11/00	75	AY970 (MLS)	CY970	EY840
A4 1.8L quattro						01/95 → 11/00		30-028495-00	21-28495-20/0	22-28825-00/0
A4 Avant 1.8L						02/96 → 09/01				ADR
A4 Avant 1.8L quattro						01/96 → 09/01				
ADR/APT/ARG	1781	4	81.00	Injection, DOHC	92/125					
AVV	1781	4	81.00	SOHC	92/125					
A4 1.8L T						12/97 → 11/00	76	AY970 (MLS)	CY970	EY840
A4 1.8L T quattro						12/97 → 11/00		30-028495-00	21-28495-20/0	22-28825-00/0
A4 Avant 1.8L T						12/97 → 09/01				
A4 Avant 1.8L T quattro						12/97 → 09/01				
AJL	1781	4	81.00		132/180					
A4 1.8L T						11/00 → 07/02	77	AY970 (MLS)	CY971	EY841
A4 1.8L T quattro						11/00 → 07/02		30-028495-00	21-28495-21/0	22-28897-02/0
AVJ	1781	4	81.00	Injection	110/150					
A4 1.8L T						07/01 → 12/04	78	AY970 (MLS)	CY971	EY841
A4 1.8L T quattro						07/01 → 12/04		30-028495-00	21-28495-21/0	22-28897-02/0
A4 Convertible 1.8L T						07/02 →			→ ch.8E-3-500 000	
A4 Convertible 1.8L T quattro						05/03 →				
BFB	1781	4	81.00	SOHC	120/163					
BKB	1781	4	81.00	Injection, DOHC	120/163					
AMB	1781	4	81.00	DOHC	125/170					
BEX	1781	4	81.00	SOHC	140/190					











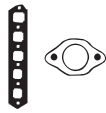

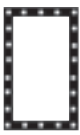

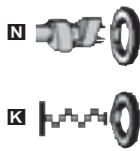









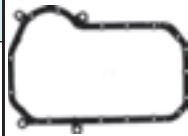











































								 AY970	 JD604	 JD605	 JJ610
HBS171  (22-39027B) M11x1.50x101mm (x10)	JD604  (31-028824-00) JD605  31-028826-00	HL732  24-28815-00/0	JJ610 (50-028825-00)	HR822 	 NA5001 (x2) 32x47x10mm, FPM (50-303185-50) ADR  NA5124 (x2) 32x47x10mm, PTFE (50-319433-00) APT/ARG/AVV  NA5001  32x47x10mm, FPM (50-303185-50) ADR  NA5124  32x47x10mm, PTFE (50-319433-00) APT/ARG/AVV  NA5133  85x105x11mm, FPM (24-30727-87/0)  LK5006  [3] 85x131x16mm, PTFE (50-319448-00)	HL5020 [245] 					
HBS171  (22-39027B) M11x1.50x101mm (x10)	JD604  (31-028824-00) JD605  31-028826-00	HL732  24-28815-00/0	JJ610 (50-028825-00)	HR822 	 NA5001 (x2) 32x47x10mm, FPM (50-303185-50)  NA5001  32x47x10mm, FPM (50-303185-50)  LK5006  [3] 85x131x16mm, PTFE (50-319448-00)  NA5133  85x105x11mm, FPM (24-30727-87/0)	HL5020 [245] 					
HBS268  (22-33031B) M10x1.50x120mm (x10)	JD604  (31-028824-00) JD605  31-028826-00	HL732  24-28815-00/0	HR397 [57] 34-000410-00	HR822 	 NA5124 (x2) 32x47x10mm, PTFE (50-319433-00)  NA5106  35x48x10mm, PTFE (50-319430-00)  LK5003  [3] 85x131x15.7mm, PTFE (50-319434-00)	HL5040 [245] 					
HBS268  (22-33031B) M10x1.50x120mm (x10)	JD604  (31-028824-00) →ch.8E-3-500 000 JD605  31-028826-00	HL732  24-28815-00/0	HR397 [57] 34-000410-00	HR822 	 NA5124 32x47x10mm, PTFE (50-319433-00)  NB716  35x48x10mm, FPM (50-306067-50)  LK5003  [3] 85x131x15.7mm, PTFE (50-319434-00)						



KW/PS



A4 1.8L T					01/95 → 11/00	79	AY970 (MLS)		CY970	EY840
A4 1.8L T quattro					01/95 → 11/00		30-028495-00		21-28495-20/0	22-28825-00/0
A4 Avant 1.8L T					03/96 → 09/01				ANB, APU, ARK	
A4 Avant 1.8L T quattro					01/96 → 09/01				CY971	
AEB	1781	4	81.00	Injection, DOHC	110/150			21-28495-21/0		
ANB/APU/ARK/AWT	1781	4	81.00	DOHC	110/150			AEB, AWT		
A4 1.9L TDI Diesel					03/00 → 11/00	80	AF5381 (MLS), 1,49mm, 1 Hole		CC5231▲	EB5370 [8]
A4 1.9L TDI quattro Diesel					03/00 → 11/00		30-030098-10		21-29463-20/0	22-29314-00/0
A4 Avant 1.9L TDI Diesel					03/00 → 09/01		AF5391 (MLS), 1,57mm, 2 Holes			
A4 Avant 1.9L TDI quattro Diesel					03/00 → 09/01		30-030099-10			
AJM	1896	4	79.50	PDi	85/116	AF5401 (MLS), 1,65mm, 3 Holes				
ATJ	1896	4	79.50		85/116	30-030100-10				
A4 1.9L TDI Diesel					12/95 → 11/00	81	BX800 (MLS), 1,45mm, 1 Hole		DX800▲	ECO30 [8]
AFF	1896	4	79.50		55/75	30-028686-00		21-27921-20/0	22-26384-04/0	
							BX810 (MLS), 1,53mm, 2 Holes		→ Eng.AFF 002 000	
							30-028687-00		DX801▲	
							BX820 (MLS), 1,61mm, 3 Holes		21-27921-21/0	
							30-028688-00		Eng.AFF 002 001 →	
A4 1.9L TDI Diesel					11/00 → 12/04	82	AF5381 (MLS), 1,49mm, 1 Hole		CC5230▲	EB5370 [8]
A4 1.9L TDI quattro Diesel					11/01 → 12/04		30-030098-10		21-29463-21/0	22-29314-00/0
AVB	1896	4	79.50		74/100	AF5391 (MLS), 1,57mm, 2 Holes				
BKE/BRB	1896	4	79.50	Direct Injection, SOHC	85/116	30-030099-10				
AVF	1896	4	79.50	PDi, SOHC	96/131	AF5401 (MLS), 1,65mm, 3 Holes				
AWX	1896	4	79.50	SOHC	96/131	30-030100-10				
A4 1.9L TDI Diesel					01/95 → 11/00	83	BX800 (MLS), 1,45mm, 1 Hole		DX800▲	ECO30 [8]
A4 Avant 1.9L TDI Diesel					02/96 → 09/01		30-028686-00		21-27921-20/0	22-26384-04/0
IZ/AHH/AHU	1896	4	79.50		66/89	BX810 (MLS), 1,53mm, 2 Holes		→ Eng.IZ 770 000		
							30-028687-00		DX801▲	
							BX820 (MLS), 1,61mm, 3 Holes		21-27921-21/0	
							30-028688-00		Eng.IZ 770 001 →	
									AHH, AHU	











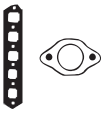

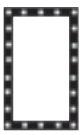

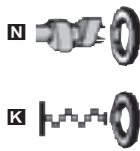

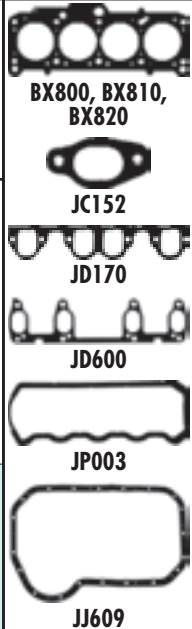













								 AY970  BX800, BX810, BX820  JC152  JD170  JD600  JD604  JD605  JP003  JJ609  JJ610
HBS171  (22-39027B) M11x1.50x101mm (x10)	JD604  (31-028824-00) JD605  31-028826-00  JE5075 (31-027178-00)	HL732  24-28815-00/0	JJ610 (50-028825-00)	HR822 	 NA5001 32x47x10mm, FPM (50-303185-50) AEB, ARK  NA5124 (x2) 32x47x10mm, PTFE (50-319433-00) ANB, APU, AWT  NA5001 32x47x10mm, FPM (50-303185-50) AEB, ARK  NA5106 35x48x10mm, PTFE (50-319430-00) AWT  NA5124 32x47x10mm, PTFE (50-319433-00) ANB, APU  NA5133 85x105x11mm, FPM (24-30727-87/0) AEB, ARK  LK5003 [3] 85x131x15.7mm, PTFE (50-319434-00) AWT  LK5006 [3] 85x131x16mm, PTFE (50-319448-00) AEB, ANB, APU, ARK	HL5020 [245]  AEB, ARK HL5040 [245]  AWT		
HBS300  (22-33034B) M12x1.75x166mm (x10)	JD170  31-026556-10 JC152  (x4) 31-026555-00  JE5075 (31-027178-00)	JM5203 50-029934-00	HR397 [57] 34-000410-00	HR816  24-30653-85/0	 NA5124 32x47x10mm, PTFE (50-319433-00)  NA5106 35x48x10mm, PTFE (50-319430-00)  LK5003 [3] 85x131x15.7mm, PTFE (50-319434-00)	HL5034 [245] 		
HBS018  (22-39024B) M12x1.75x115mm (x10)	JD170  31-026556-10 JC152  (x4) 31-026555-00	JP003 50-027921-00	JJ609 (50-027500-00) (ACM)	HR569  24-30667-00/0 →Eng.AFF 002 HR816  24-30653-85/0 Eng.AFF 002 001 →	 NA5001 32x47x10mm, FPM (50-303185-50)  NA5001 32x47x10mm, FPM (50-303185-50)  LK5006 [3] 85x131x16mm, PTFE (50-319448-00)  NA5133 85x105x11mm, FPM (24-30727-87/0)	HL5020 [245]  NA5278 [54]		
HBS300  (22-33034B) M12x1.75x166mm (x10)	JD170  31-026556-10 JD600  31-028454-00	JM5203 50-029934-00	HR397 [57] 34-000410-00	HR816  24-30653-85/0	 NA5124 32x47x10mm, PTFE (50-319433-00)  NA5106 35x48x10mm, PTFE (50-319430-00)  LK5003 [3] 85x131x15.7mm, PTFE (50-319434-00)	HL5034 [245] 		
HBS018  (22-39024B) M12x1.75x115mm (x10)	JD170  31-026556-10 JC152  (x4) 31-026555-00  JE5075 (31-027178-00)	JP003 50-027921-00	JJ609 (50-027500-00) (ACM)	HR569  24-30667-00/0 →Eng.1Z 770 000 HR816  24-30653-85/0 Eng.1Z 770 001 → AHH, AHU	 NA5001 32x47x10mm, FPM (50-303185-50)  NA5001 32x47x10mm, FPM (50-303185-50)  NA5133 85x105x11mm, FPM (24-30727-87/0) 1Z, AHU  LK5006 [3] 85x131x16mm, PTFE (50-319448-00) AHH	HL5020 [245]  NA5278 [54]		



KW/PS



Audi Model and Year						84	Engine Details	Part Numbers	Accessories
A4 1.9L TDI Diesel						10/95 → 11/00	BX800 (MLS), 1.45mm, 1 Hole 30-028686-00 BX810 (MLS), 1.53mm, 2 Holes 30-028687-00 BX820 (MLS), 1.61mm, 3 Holes 30-028688-00	DX800 ▲ 21-27921-20/0 →Eng.AFN 002 000 DX801 ▲ 21-27921-21/0 Eng.AFN 002 001 → AVG	EC030 [8] 22-26384-04/0
A4 1.9L TDI quattro Diesel						09/96 → 11/00			
A4 Avant 1.9L TDI Diesel						02/96 → 09/01			
A4 Avant 1.9L TDI quattro Diesel						09/96 → 09/01			
AFN	1896	4	79.50	SOHC	81/110				
AVG	1896	4	79.50		81/110				
A4 Avant 1.9L TDI Diesel						03/96 → 09/01	BX800 (MLS), 1.45mm, 1 Hole 30-028686-00 BX810 (MLS), 1.53mm, 2 Holes 30-028687-00 BX820 (MLS), 1.61mm, 3 Holes 30-028688-00	DX800 ▲ 21-27921-20/0 →Eng.AFF 002 000 DX801 ▲ 21-27921-21/0 Eng.AFF 002 001 →	EC030 [8] 22-26384-04/0
A4 Avant 1.9L TDI quattro Diesel						03/96 → 09/01			
A4 Avant 2.0L TDI Diesel						11/04 →			
A4 Avant 2.0L TDI quattro Diesel						01/06 →			
A4 Convertible 2.0L TDI Diesel						10/05 →	AG9630 (MLS), 1.45mm, 1 Hole 30-030349-00 AG9640 (MLS), 1.53mm, 2 Holes AG9650 (MLS), 1.61mm, 3 Holes	CC5230 ▲ 21-29463-21/0	EB5370 [8] 22-29314-00/0
A4 2.0L TDI Diesel						11/04 →			
A4 2.0L TDI quattro Diesel						01/06 →			
A4 Avant 2.0L TDI Diesel						10/05 →			
BPW	1968	4	81.00	Direct Injection, SOHC	103/140				
A4 Avant 2.0L FSI						01/05 → 07/05	AG9600 (MLS) 30-030352-00	CG9600 21-30352-00/0	
A4 2.0L FSI						07/02 → 07/05			
AWA	1984	4	82.50	DOHC	110/150				
A4 2.0L						11/00 → 12/04	AG8810 (MLS) 30-030214-00	CG8420 21-30214-00/0	
A4 Avant 2.0L						09/01 → 12/04			
A4 Convertible 2.0L						09/04 →			
ALT	1984	4	82.50	Injection	96/131				
A4 2.0L TDI Diesel						11/04 →	AG8970 (MLS), 1.55mm, 1 Hole 30-030249-00 AG8800 (MLS), 1.63mm, 2 Holes (30-030213-00) AG8960 (MLS), 1.71mm, 3 Holes (30-030248-00)	CG8410 ▲ 21-30213-00/0	EF5380 22-30369-00/0
A4 2.0L TDI 16V Diesel						11/04 →			
A4 2.0L TDI quattro Diesel						06/06 →			
A4 Avant 2.0L TDi Diesel						06/06 →			
A4 Avant 2.0L TDi quattro Diesel						06/06 →			
BNA/BRF	1968	4	81.00	Direct Injection, DOHC	100/136				
BLB/BRE	1968	4	81.00	Direct Injection, DOHC	103/140				
BRD	1968	4	81.00	Direct Injection, SOHC					
A4 2.4L						03/97 → 12/04	BZ960 (MLS) (x2) (30-028653-00)	DZ960 ■○ (x2) (21-28653-20/0) Ch.8D W 180 000 →	
A4 2.4L quattro						03/97 → 11/00			
A4 Avant 2.4L						03/97 → 09/01			
A4 Avant 2.4L quattro						03/97 → 09/01			
A4 Convertible 2.4L						04/02 →			
AIG	2393	6	81.00	DOHC, V6	120/163				
AMM	2393	6	81.00	V6	120/163				
APS	2393	6	81.00	DOHC, V6	120/163				
AGA/ALF/AML	2393	6	81.00	DOHC, V6	121/165				
APZ	2393	6	81.00	V6	121/165				
ARJ	2393	6	81.00	DOHC, V6	121/165				
BDV	2393	6	81.00	V6	125/170				

								
HBS018 Ⓞ (22-39024B) M12x1.75x115mm (x10)	JD170 ■ 31-026556-10 JC152 ■ (x4) 31-026555-00  JE5075 (31-027178-00)	JP003 50-027921-00	JJ609 (50-027500-00) (ACM)	HR569 ■ 24-30667-00/0 →Eng.AFN 002 000 HR816 ■ 24-30653-85/0 Eng.AFN 002 001 → AVG	 NA5001 32x47x10mm, FPM (50-303185-50)  NA5001 ■ 32x47x10mm, FPM (50-303185-50)  NA5133 ■ 85x105x11mm, FPM (24-30727-87/0)  LK5006 ■ [3] 85x131x16mm, PTFE (50-319448-00)	HL5020 [245]■ NA5278 [54]		
HBS018 Ⓞ (22-39024B) M12x1.75x115mm (x10)	JD170 ■ 31-026556-10 JC152 ■ (x4) 31-026555-00	JP003 50-027921-00	JJ609 (50-027500-00) (ACM)	HR569 ■ 24-30667-00/0 →Eng.AFF 002 000 HR816 ■ 24-30653-85/0 Eng.AFF 002 001 →	 NA5001 32x47x10mm, FPM (50-303185-50)  NA5001 ■ 32x47x10mm, FPM (50-303185-50)  NA5133 ■ 85x105x11mm, FPM (24-30727-87/0)  LK5006 ■ [3] 85x131x16mm, PTFE (50-319448-00)	HL5020 [245]■		
HBS300 Ⓞ (22-33034B) M12x1.75x166mm (x10)	JD170 ■ 31-026556-10 JD600 ■ 31-028454-00	JM5203 50-029934-00	HR397 [57] 34-000410-00	HR816 ■ 24-30653-85/0	 NA5124 32x47x10mm, PTFE (50-319433-00)  NA5106 ■ 35x48x10mm, PTFE (50-319430-00)  LK5003 ■ [3] 85x131x15.7mm, PTFE (50-319434-00)	HL5034 [245]■		
HBS363 Ⓞ (22-33038B) M10x1.50x122mm (x10)	JD5873 ■ 50-030353-00 (FPM) JD5813 ■ 31-030233-00	JM7048 50-030354-00 (Rubber/Metal)	HR397 [57] 34-000410-00	HR791 ■ 24-30614-76/0	 NA5124 32x47x10mm, PTFE (50-319433-00)  NA5106 ■ 35x48x10mm, PTFE (50-319430-00)  LK5008 ■ [3] 85x131x15.7mm, PTFE (50-319472-00)	HL5034 [245]■		
	JD5820 ■ (x4) 50-030250-00 JD5813 ■ 31-030233-00	JM7030 (31-030222-00) (Rubber/Metal)	HR397 [57] 34-000410-00	HR822 ■	 NA5124 (x2) 32x47x10mm, PTFE (50-319433-00)  NA5106 ■ 35x48x10mm, PTFE (50-319430-00)  LK5008 ■ [3] 85x131x15.7mm, PTFE (50-319472-00)	HL5040 [245]■		
HBS364 Ⓞ (22-39032B) M12x1.75x149mm (x10)	JD5806 ■ 31-030226-00 JD5815 ■ 31-030235-00	JM7029 (50-030221-00)	HR397 [57] 34-000410-00	HR791 ■ 24-30614-76/0	 NA5124 32x47x10mm, PTFE (50-319433-00)  NA5106 ■ 35x48x10mm, PTFE (50-319430-00)  LK5012 ■ [3][B5] 85x132x15.7mm, ACM (50-319535-00)	HL5034 [245]■ KK5522 [86]		
HBS270 Ⓞ (22-33033B) M11x1.50x133mm (x16)		HM5224 ■ (x2) 24-28647-00/0		HR791 ■ (x2) 24-30614-76/0	 NA5001 (x4) 32x47x10mm, FPM (50-303185-50)  NA5106 ■ 35x48x10mm, PTFE (50-319430-00) ARJ, BDV  NB716 ■ 35x48x10mm, FPM (50-306067-50) AGA, AJG, ALF, AML AMM, APS, APZ			

AUDI



KW/PS



A4 2.5L D Diesel 10/00 → 05/03 91						AC5960 (MLS), 1.10mm, 1 Hole (x2) 30-029397-00 AC5970 (MLS), 1.15mm, 2 Holes (x2) 30-029398-00 AC5980 (MLS), 1.20mm, 3 Holes (x2) 30-029399-00	CC5960▲ 21-29397-00/0	
A4 Avant 2.5L TDi Diesel 09/97 → 05/03								
A4 2.5L TDI Diesel 09/97 → 12/04								
A4 2.5L TDI quattro Diesel 09/97 → 12/04								
A4 Avant 2.5L TDI quattro Diesel 09/97 → 09/01								
A4 Convertible 2.5L TDI Diesel 08/02 →								
AFB/AKN	2496	6	78.30	DOHC, V6	110/150			
AYM	2496	6	78.30	V6	114/155			
BCZ/BDG/BFC	2496	6	78.30	DOHC, V6	120/163			
AKE/BAU/BDH	2496	6	78.30	DOHC, V6	132/180			
A4 2.6L 01/95 → 11/00 92						AY060 (Fibre), 2.00mm (x2) 30-027222-20	DT660 21-27222-20/0 → Ch.8D-T-076 000 DY850 21-27222-21/0 Ch.8D-T-076 001 →	EY850 (22-28635-00/0) Ch.8D-T-076 001 →
A4 2.6L quattro 01/95 → 11/00								
A4 Avant 2.6L 02/96 → 09/01								
A4 Avant 2.6L quattro 01/96 → 09/01								
ABC	2598	6	82.50	Injection, V6	110/150			
A4 2.7L TDI Diesel 11/05 → 93						AG8880 (MLS), 1.1mm, 1 Hole [87] 30-030240-00 AG8900 (MLS), 1.1mm, 1 Hole [88] 30-030242-00 AG8860 (MLS), 1.15mm, 2 Holes [87] 30-030219-00 AG8870 (MLS), 1.15mm, 2 Holes [88] 30-030220-00 AG8890 (MLS), 1.2mm, 3 Holes [87] 30-030241-00 AG8910 (MLS), 1.2mm, 3 Holes [88] 30-030243-00		
A4 Avant 2.7L TDi Diesel 11/05 → 03/08								
A4 Convertible 2.7L TDi Diesel 06/06 →								
BSG	2698	6	81.40	Direct Injection, DOHC, V6	120/163			
BPP	2698	6	81.40	Direct Injection, DOHC, V6	132/180			
A4 2.8L 09/95 → 07/97 94						AY060 (Fibre), 2.00mm (x2) 30-027222-20	DT660 21-27222-20/0 → Ch.8D-T-076 000 DY850 21-27222-21/0 Ch.8D-T-076 001 →	EY850 (22-28635-00/0) Ch.8D-T-076 001 →
A4 2.8L quattro 01/95 → 07/97								
A4 Avant 2.8L 03/96 → 09/96								
A4 Avant 2.8L quattro 01/96 → 09/96								
AAH	2771	6	82.50	MH-Motronic, V6	128/174			
A4 3.0L TDI quattro Diesel 11/04 → 95						AG8880 (MLS), 1.1mm, 1 Hole [87] 30-030240-00 AG8900 (MLS), 1.1mm, 1 Hole [88] 30-030242-00 AG8860 (MLS), 1.15mm, 2 Holes [87] 30-030219-00 AG8870 (MLS), 1.15mm, 2 Holes [88] 30-030220-00 AG8890 (MLS), 1.2mm, 3 Holes [87] 30-030241-00 AG8910 (MLS), 1.2mm, 3 Holes [88] 30-030243-00		
A4 Avant 3.0L TDI quattro Diesel 11/04 →								
A4 Convertible 3.0L TDI quattro Diesel 10/05 →								
BKN	2967	6	83.00	Direct Injection, V6	150/204			
ASB	2967	6	83.00		171/232			

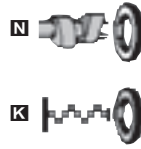
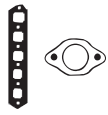

AC5960, AC5970,
AC5980



AY060











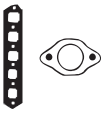

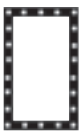

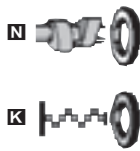















































<p>HBS265⊕ (22-33027B) M12x1.50x155mm (x16) AFB, AKE, AKN, AYM, BFC HBS361⊕ (22-33037B) M12x1.50x159mm (x16) BAU, BCZ, BDG, BDH</p>	<p>JD5810■ (x2) (31-030230-00) JD5851■ (x6) 31-030293-00 (Fibre)</p>	<p>HM5223■ (x2) 24-30020-00/0 (ACM)</p>	<p>HR397 [57] 34-000410-00 AYM, BAU, BCZ, BDG, BDH, BFC</p>	<p>HR5062■ 24-30614-73/0</p>	<p>■ NA5001 (x2) 32x47x10mm, FPM (50-303185-50) ■ NB716■ 35x48x10mm, FPM (50-306067-50)</p>	
<p>HBS064⊕ (22-39010B) M11x1.50x137mm (x16)</p>		<p>JM5166 (x2) 50-027936-00 (ACM) →Ch.8D-T-076 000</p>	<p>JH5118 (31-028635-00)</p>	<p>HR602■ 24-30670-61/0</p>	<p>■ NA5001 (x3) 32x47x10mm, FPM (50-303185-50) ■ NB716■ 35x48x10mm, FPM (50-306067-50) ■ NA5133■ 85x105x11mm, FPM (24-30727-87/0)</p>	
<p>HBS361⊕ (22-33037B) M12x1.50x159mm (x16)</p>	<p>JD5872■ (x2) 50-030355-00 (ACM)</p>	<p>JM7046 [87] 50-030356-00 (ACM) JM7047 [88] 50-030357-00 (ACM)</p>	<p>HR397 [57] 34-000410-00</p>	<p>HR5062■ 24-30614-73/0</p>	<p>■ NA5001 (x2) 32x47x10mm, FPM (50-303185-50)</p>	
<p>HBS064⊕ (22-39010B) M11x1.50x137mm (x16)</p>		<p>JM5166 (x2) 50-027936-00 (ACM) →Ch.8D-T-076 000</p>	<p>JH5118 (31-028635-00)</p>	<p>HR602■ 24-30670-61/0</p>	<p>■ NA5001 (x3) 32x47x10mm, FPM (50-303185-50) ■ NB716■ 35x48x10mm, FPM (50-306067-50) ■ NA5133■ 85x105x11mm, FPM (24-30727-87/0)</p>	
<p>HBS361⊕ (22-33037B) M12x1.50x159mm (x16)</p>	<p>JD5872■ (x2) 50-030355-00 (ACM)</p>	<p>JM7046 [87] 50-030356-00 (ACM) JM7047 [88] 50-030357-00 (ACM)</p>	<p>HR397 [57] 34-000410-00</p>	<p>HR5062■ 24-30614-73/0</p>	<p>■ NA5001 (x2) 32x47x10mm, FPM (50-303185-50)</p>	



KW/PS



A6 1.8L 12/95 → 01/05 96						AY970 (MLS) 30-028495-00	CY970 21-28495-20/0	EY840 22-28825-00/0			
A6 1.8L quattro 12/95 → 02/97											
A6 1.8L T 12/97 → 01/05											
A6 1.8L T quattro 12/97 → 01/05											
A6 Avant 1.8L 12/95 → 01/05											
A6 Avant 1.8L quattro 12/95 → 12/97											
A6 Avant 1.8L T 04/99 → 01/05											
A6 Avant 1.8L T quattro 12/97 → 01/05											
AFY	1781	4	81.00	DOHC	85/116						
ADR	1781	4	81.00	Injection, DOHC	92/125						
AJL	1781	4	81.00		132/180						
A6 1.8L 07/97 → 01/05 97						AY970 (MLS) 30-028495-00		EC5220 [8] [22-29462-00/0]			
A6 Avant 1.8L 12/97 → 01/05											
AJP	1781	4	81.00	SOHC	92/125						
ANQ	1781	4	81.00	Injection, DOHC	92/125						
AQE/ARH	1781	4	81.00	SOHC	92/125						
A6 1.8L T 01/97 → 01/05 98						AY970 (MLS) 30-028495-00	CY970 21-28495-20/0 AEB, ANB, APU, ARK CY971 21-28495-21/0 AWT	EY840 22-28825-00/0			
A6 1.8L T quattro 02/97 → 01/05											
A6 Avant 1.8L T 12/97 → 01/05											
A6 Avant 1.8L T quattro 12/97 → 01/05											
AEB	1781	4	81.00	Injection, DOHC	110/150						
ANB/APU/ARK	1781	4	81.00	DOHC	110/150						
AWL	1781	4	81.00	Injection	110/150						
AWT	1781	4	81.00	DOHC	110/150						
A6 1.9L TDI Diesel 07/00 → 01/05 99						AF5381 (MLS) , 1,49mm, 1 Hole 30-030098-10 AF5391 (MLS) , 1,57mm, 2 Holes 30-030099-10 AF5401 (MLS) , 1,65mm, 3 Holes 30-030100-10	CC5231▲ 21-29463-20/0	EB5370 [8] 22-29314-00/0			
A6 Avant 1.9L TDI Diesel 07/00 → 01/05											
AJM	1896	4	79.50	PDi	85/116						
A6 1.9L TDI Diesel 08/01 → 01/05 100						AF5381 (MLS) , 1,49mm, 1 Hole 30-030098-10 AF5391 (MLS) , 1,57mm, 2 Holes 30-030099-10 AF5401 (MLS) , 1,65mm, 3 Holes 30-030100-10	CC5230▲ 21-29463-21/0	EB5370 [8] 22-29314-00/0			
A6 Avant 1.9L TDI Diesel 08/01 → 01/05											
AVF	1896	4	79.50	PDi, SOHC	96/131						
AWX	1896	4	79.50	SOHC	96/131						







								 AY970  JC152  JD170  JD600  JD604  JD605  JE689  JJ610
HBS171  (22-39027B) M11x1.50x101mm (x10)	JD604  (31-028824-00) JD605  31-028826-00	HL732  24-28815-00/0	JJ610 (50-028825-00)	HR822 	 NA5001 (x2) 32x47x10mm, FPM (50-303185-50)  NA5001 32x47x10mm, FPM (50-303185-50)  NA5133 85x105x11mm, FPM (24-30727-87/0)  LK5006 [3] 85x131x16mm, PTFE (50-319448-00)			
HBS268  (22-33031B) M10x1.50x120mm (x10)	JD604  (31-028824-00) JD605  31-028826-00  JE689 (31-024039-00)	HL732  24-28815-00/0	JH5117 (50-030046-00)	HR822 	 NA5124 32x47x10mm, PTFE (50-319433-00)  NA5106 35x48x10mm, PTFE (50-319430-00)  LK5008 [3] 85x131x15.7mm, PTFE (50-319472-00)			
HBS171  (22-39027B) M11x1.50x101mm (x10) AEB, ANB, APU, ARK HBS268  (22-33031B) M10x1.50x120mm (x10) AWT	JD604  (31-028824-00) JD605  31-028826-00	HL732  24-28815-00/0	HR397 [57] 34-000410-00 AWT JJ610 (50-028825-00) AEB, ANB, APU, ARK	HR822 	 NA5001 (x2) 32x47x10mm, FPM (50-303185-50) AEB, ARK  NA5124 (x2) 32x47x10mm, PTFE (50-319433-00) ANB, APU, AWT  NA5001 32x47x10mm, FPM (50-303185-50) AEB, ARK  NA5106 35x48x10mm, PTFE (50-319430-00) AWT  NA5124 32x47x10mm, PTFE (50-319433-00) ANB, APU  NA5133 85x105x11mm, FPM (24-30727-87/0) AEB, ARK  LK5003 [3] 85x131x15.7mm, PTFE (50-319434-00) AWT  LK5006 [3] 85x131x16mm, PTFE (50-319448-00) AEB, ARK, ANB, APU			
HBS300  (22-33034B) M12x1.75x166mm (x10)	JD170  31-026556-10 JC152  (x4) 31-026555-00  JE5075 (31-027178-00)	JM5203 50-029934-00	HR397 [57] 34-000410-00	HR816  24-30653-85/0	 NA5124 32x47x10mm, PTFE (50-319433-00)  NA5106 35x48x10mm, PTFE (50-319430-00)  LK5003 [3] 85x131x15.7mm, PTFE (50-319434-00)	HL5034 [245] 		
HBS300  (22-33034B) M12x1.75x166mm (x10)	JD170  31-026556-10 JD600  31-028454-00	JM5203 50-029934-00	HR397 [57] 34-000410-00	HR816  24-30653-85/0	 NA5124 32x47x10mm, PTFE (50-319433-00)  NA5106 35x48x10mm, PTFE (50-319430-00)  LK5003 [3] 85x131x15.7mm, PTFE (50-319434-00)	HL5034 [245] 		

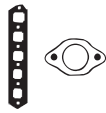

KW/PS

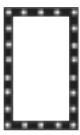

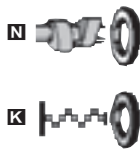
A6 1.9L TDI Diesel		06/94 → 02/97		101		BX800 (MLS), 1.45mm, 1 Hole 30-028686-00		DX800▲ 21-27921-20/0 → Eng. 1Z 770 000		ECO30 [8] 22-26384-04/0	
A6 Avant 1.9L TDI Diesel		06/94 → 12/97				BX810 (MLS), 1.53mm, 2 Holes 30-028687-00		DX801▲ 21-27921-21/0 Eng. 1Z 770 001 → AHU			
1Z/AHU		1896 4 79.50		66/89		BX820 (MLS), 1.61mm, 3 Holes 30-028688-00					
A6 1.9L TDI Diesel		02/97 → 01/05		102		BX800 (MLS), 1.45mm, 1 Hole 30-028686-00		DX800▲ 21-27921-20/0 → Eng. AFN 002 000		ECO30 [8] 22-26384-04/0	
A6 Avant 1.9L TDI Diesel		12/97 → 01/05				BX810 (MLS), 1.53mm, 2 Holes 30-028687-00		DX801▲ 21-27921-21/0 Eng. AFN 002 001 → AVG			
AFN		1896 4 79.50		SOHC 81/110		BX820 (MLS), 1.61mm, 3 Holes 30-028688-00					
AVG		1896 4 79.50		81/110							
A6 2.0L		08/01 → 01/05		103		AG8810 (MLS) 30-030214-00		CG8420 21-30214-00/0			
A6 Avant 2.0L		08/01 → 01/05									
ALT		1984 4 82.50		Injection 96/131							
A6 2.0L		06/94 → 02/97		104		BY750 (MLS) 30-027930-00		DY750 21-27930-40/0		EB970 22-27500-01/0	
A6 Avant 2.0L		06/94 → 12/97									
AAE		1984 4 82.50		Monomotronic 74/100							
A6 2.0L		06/94 → 02/97		105		BT810 (Fibre) 30-027257-20 → Ch. 4A-S-110 000		DT815 21-27257-23/0 → Ch. 4A-S-110 000		EB970 22-27500-01/0	
A6 Avant 2.0L		06/94 → 12/97				BY750 (MLS) 30-027930-00 Ch. 4A-S-110 001 →		DY750 21-27930-40/0 Ch. 4A-S-110 001 →			
ABK		1984 4 82.50		Digifant 85/116							
A6 2.0L 16V		06/94 → 02/97		106		BY750 (MLS) 30-027930-00		DY751 21-27930-24/0 → Eng. ACE 017 542		EB970 22-27500-01/0	
A6 2.0L 16V quattro		06/94 → 02/97						DY752 21-27930-25/0 Eng. ACE 017 543 →			
A6 Avant 2.0L 16V		06/94 → 12/97									
A6 Avant 2.0L 16V quattro		06/94 → 12/97									
ACE		1984 4 82.50		KE-Motronic 103/140							
A6 2.0L TDI Diesel		07/04 →		107		AG8970 (MLS), 1.55mm, 1 Hole 30-030249-00		CG8410▲ 21-30213-00/0		EF5380 22-30369-00/0	
BNA/BRF/CAGB		1968 4 81.00		Direct Injection, DOHC 100/136		AG8800 (MLS), 1.63mm, 2 Holes (30-030213-00)					
BLB/BRE		1968 4 81.00		Direct Injection, DOHC 103/140		AG8960 (MLS), 1.71mm, 3 Holes (30-030248-00)					

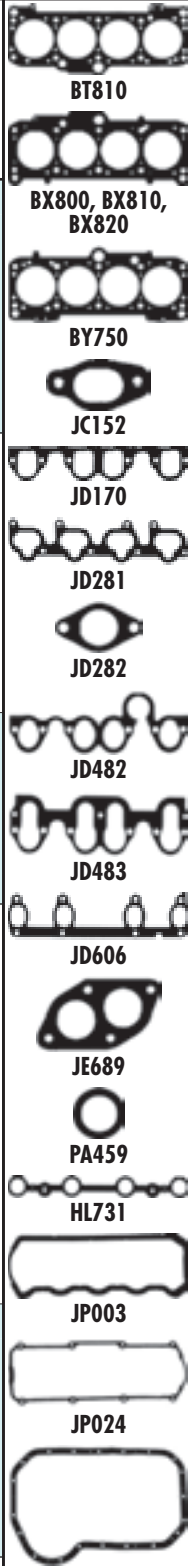













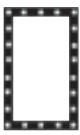

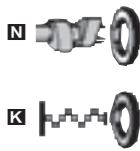

								
HBS018 Ⓞ (22-39024B) M12x1.75x115mm (x10)	JD170 ■ 31-026556-10 JC152 ■ (x4) 31-026555-00	JP003 50-027921-00	JJ609 (50-027500-00) (ACM)	HR569 ■ 24-30667-00/0 →Eng.1Z 770 000 HR816 ■ 24-30653-85/0 Eng.1Z 770 001→	NA5001 32x47x10mm, FPM (50-303185-50) NA5001 ■ 32x47x10mm, FPM (50-303185-50) NA5133 ■ 85x105x11mm, FPM (24-30727-87/0)	HL5020 [245]■ NA5278 [54]		BT810 BX800, BX810, BX820 BY750 JC152 JD170 JD281 JD282 JD482 JD483 JD606 JE689 PA459 HL731 JP003 JP024 JJ609
HBS018 Ⓞ (22-39024B) M12x1.75x115mm (x10)	JD170 ■ 31-026556-10 JC152 ■ (x4) 31-026555-00 JE5075 (31-027178-00)	JP003 50-027921-00	JJ609 (50-027500-00) (ACM)	HR569 ■ 24-30667-00/0 →Eng.AFN 002 000 HR816 ■ 24-30653-85/0 Eng.AFN 002 001→ AVG	NA5001 32x47x10mm, FPM (50-303185-50) NA5001 ■ 32x47x10mm, FPM (50-303185-50) NA5133 ■ 85x105x11mm, FPM (24-30727-87/0) LK5006 ■ [3] 85x131x16mm, PTFE (50-319448-00)	HL5020 [245]■ NA5278 [54]		
	JD5820 ■ (x4) 50-030250-00 JD5813 ■ 31-030233-00	JM7030 (31-030222-00) (Rubber/Metal)	HR397 [57] 34-000410-00	HR822 ■	NA5124 (x2) 32x47x10mm, PTFE (50-319433-00) NA5106 ■ 35x48x10mm, PTFE (50-319430-00) LK5008 ■ [3] 85x131x15.7mm, PTFE (50-319472-00)	HL5040 [245]■		
	JD482 ■ (31-027351-00) JD483 ■ (31-027352-00) PA459 ■ 50-024870-00 (NBR) JC152 ■ (x4) 31-026555-00 JD606 ■ (31-028918-00) JE689 (31-024039-00)	JP024 50-027505-00	JJ609 (50-027500-00) (ACM)	HR569 ■ 24-30667-00/0 →Eng.AAE-032 209 HR816 ■ 24-30653-85/0 Eng.AAE-032 210→	NA5001 32x47x10mm, FPM (50-303185-50) NA5001 ■ 32x47x10mm, FPM (50-303185-50) NA5133 ■ 85x105x11mm, FPM (24-30727-87/0)	HL5020 [245]■		
HBS043 Ⓞ (22-39001B) M11x1.50x95mm (x10) →Ch.4A-5-110 000	JD482 ■ (31-027351-00) JD483 ■ (31-027352-00) JC152 ■ (x4) 31-026555-00 JD606 ■ (31-028918-00)	JP024 50-027505-00	JJ609 (50-027500-00) (ACM)	HR569 ■ 24-30667-00/0 →Eng.ABK 245 263 HR816 ■ 24-30653-85/0 Eng.ABK 245 264→	NA5001 32x47x10mm, FPM (50-303185-50) NA5001 ■ 32x47x10mm, FPM (50-303185-50) NA5133 ■ 85x105x11mm, FPM (24-30727-87/0)	HL5020 [245]■		
HBS028 Ⓞ (22-39004B) M11x1.50x147mm (x10)	JD281 ■ (31-027904-00) JD282 ■ (x4) (31-026880-00) JE689 (31-024039-00)	HL606 ■ 24-26237-01/0 →Eng.ACE 017 542 HL731 ■ 24-27937-00/0 Eng.ACE 017 543→		HR816 ■ (x2) 24-30653-85/0	NA5001 32x47x10mm, FPM (50-303185-50) NA5001 ■ 32x47x10mm, FPM (50-303185-50) NA5133 ■ 85x105x11mm, FPM (24-30727-87/0)	HL5020 [245]■		
HBS364 Ⓞ (22-39032B) M12x1.75x149mm (x10)	JD5806 ■ 31-030226-00 JD5815 ■ 31-030235-00	JM7029 (50-030221-00)	HR397 [57] 34-000410-00	HR791 ■ 24-30614-76/0	NA5124 32x47x10mm, PTFE (50-319433-00) NA5106 ■ 35x48x10mm, PTFE (50-319430-00) LK5012 ■ [85] 85x132x15.7mm, ACM (50-319535-00)	HL5034 [245]■ KK5522 [86]		



KW/PS



A6 2.2L S6 Turbo quattro		06/94 → 02/97		108		AY960 (MLS)		CY960		ECO10	
A6 Avant 2.2L S6 Turbo quattro		06/94 → 12/97				30-028016-00		21-28016-20/0		(22-26274-00/0)	
AAN	2226	5	81.00			169/230					
A6 2.3L		06/94 → 12/95		109		BT820 (Fibre)		DT820		EX995	
AAR	2309	5	82.50			98/133		21-26082-21/0		(22-23856-06/0)	
A6 2.3L quattro		06/94 → 12/95		110		BT820 (Fibre)		DT820		EX995	
A6 Avant 2.3L		06/94 → 12/95						21-26082-21/0		(22-23856-06/0)	
A6 Avant 2.3L quattro		06/94 → 12/95									
AAR	2309	5	82.50			98/133					
A6 2.4L		02/97 → 01/05		111		BZ960 (MLS) (x2)		DZ960 (x2)			
A6 2.4L quattro		02/97 → 01/05				(30-028653-00)		(21-28653-20/0)			
A6 Avant 2.4L		12/97 → 01/05						Ch.4B-W-150 001 →			
A6 Avant 2.4L quattro		12/97 → 01/05									
ALW/ARN/ASM	2393	6	81.00	DOHC, V6		100/136					
APC	2393	6	81.00	DOHC, V6		115/156					
AJG	2393	6	81.00	DOHC, V6		120/163					
AMM	2393	6	81.00	V6		120/163					
APS	2393	6	81.00	DOHC, V6		120/163					
AGA/ALF/AML	2393	6	81.00	DOHC, V6		121/165					
APZ	2393	6	81.00	V6		121/165					
ARJ	2393	6	81.00	DOHC, V6		121/165					
BDV	2393	6	81.00	V6		125/170					
A6 2.5L TDI Diesel		02/00 → 01/05		112		AC5960 (MLS), 1.10mm, 1 Hole (x2)		CC5960▲			
A6 2.5L TDI quattro Diesel		02/00 → 01/05				30-029397-00		21-29397-00/0			
A6 Avant 2.5L TDI Diesel		02/00 → 01/05				AC5970 (MLS), 1.15mm, 2 Holes (x2)					
A6 Avant 2.5L TDI quattro Diesel		02/00 → 01/05				30-029398-00					
AKE/BAU/BDH	2496	6	78.30	DOHC, V6		132/180	AC5980 (MLS), 1.20mm, 3 Holes (x2)				
BND	2496	6	78.30	Direct Injection, DOHC, V6		132/180	30-029399-00				
A6 2.5L TDI Diesel		07/97 → 01/05		113		AC5960 (MLS), 1.10mm, 1 Hole (x2)		CC5960▲			
A6 2.5L TDI quattro Diesel		07/97 → 01/05				30-029397-00		21-29397-00/0			
A6 Avant 2.5L TDI Diesel		12/97 → 01/05				AC5970 (MLS), 1.15mm, 2 Holes (x2)					
A6 Avant 2.5L TDI quattro Diesel		12/97 → 01/05				30-029398-00					
AFB/AKN	2496	6	78.30	DOHC, V6		110/150	AC5980 (MLS), 1.20mm, 3 Holes (x2)				
AYM	2496	6	78.30	V6		114/155	30-029399-00				
A6 2.5L TDI Diesel		07/02 → 01/05		114		AC5960 (MLS), 1.10mm, 1 Hole (x2)		CC5960▲			
A6 Avant 2.5L TDI Diesel		07/02 → 01/05				30-029397-00		21-29397-00/0			
BCZ/BDG/BFC	2496	6	78.30	DOHC, V6		120/163	AC5970 (MLS), 1.15mm, 2 Holes (x2)				
							30-029398-00				
							AC5980 (MLS), 1.20mm, 3 Holes (x2)				
							30-029399-00				











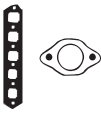

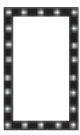

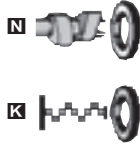

























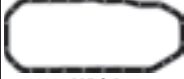







																				
HBS269 Ⓞ (22-33032B) M11x1.50x141.5mm (x12)	JD602 ■ (31-026277-00) JD282 ■ (x5) (31-026880-00) JD603 ■ (31-027514-00)	HL730 ■ 24-27424-00/0	JJ501 (31-027042-00)			NA5001 32x47x10mm, FPM (50-303185-50) NB716 ■ 35x48x10mm, FPM (50-306067-50) NA5133 ■ 85x105x11mm, FPM (24-30727-87/0)												 AC5960, AC5970, AC5980		
HBS024 Ⓞ (22-39002B) M11x1.50x95mm (x12)	JD171 ■ 31-027048-00 JD327 ■ (31-026472-00) JC152 ■ (x5) 31-026555-00 JE689 (31-024039-00)		JJ184 (31-023856-10)		HR615 ■ 24-30667-05/0	NA5001 32x47x10mm, FPM (50-303185-50) NB716 ■ 35x48x10mm, FPM (50-306067-50) NA5133 ■ 85x105x11mm, FPM (24-30727-87/0)												 AY960		
HBS024 Ⓞ (22-39002B) M11x1.50x95mm (x12)	JD327 ■ (31-026472-00) JD171 ■ 31-027048-00 JC152 ■ (x5) 31-026555-00 JE689 (31-024039-00)		JJ184 (31-023856-10)		HR615 ■ 24-30667-05/0	NA5001 32x47x10mm, FPM (50-303185-50) NB716 ■ 35x48x10mm, FPM (50-306067-50) NA5133 ■ 85x105x11mm, FPM (24-30727-87/0)												 BT820		
HBS270 Ⓞ (22-33033B) M11x1.50x133mm (x16)		HM5224 ■ (x2) 24-28647-00/0				NA5001 (x4) 32x47x10mm, FPM (50-303185-50) NA5106 ■ 35x48x10mm, PTFE (50-319430-00) ARJ, ASM, BDV NB716 ■ 35x48x10mm, FPM (50-306067-50) AGA, ALF, ALW, AML, APS, ARN												 JC152		
HBS265 Ⓞ (22-33027B) M12x1.50x155mm (x16) AKE HBS361 Ⓞ (22-33037B) M12x1.50x159mm (x16) BAU, BDH, BND	JD5810 ■ (x2) (31-030230-00) JD5851 ■ (x6) 31-030293-00 (Fibre)	HM5223 ■ (x2) 24-30020-00/0 (ACM)			HR5062 ■ 24-30614-73/0	NA5001 (x2) 32x47x10mm, FPM (50-303185-50) NB716 ■ 35x48x10mm, FPM (50-306067-50)												 JD171		
HBS265 Ⓞ (22-33027B) M12x1.50x155mm (x16)	JD5810 ■ (x2) (31-030230-00) JD5851 ■ (x6) 31-030293-00 (Fibre)	HM5223 ■ (x2) 24-30020-00/0 (ACM)			HR5062 ■ 24-30614-73/0	NA5001 (x2) 32x47x10mm, FPM (50-303185-50) NB716 ■ 35x48x10mm, FPM (50-306067-50)												 JD282		
HBS265 Ⓞ (22-33027B) M12x1.50x155mm (x16) BFC HBS361 Ⓞ (22-33037B) M12x1.50x159mm (x16) BDG, BCZ	JD5810 ■ (x2) (31-030230-00) JD5851 ■ (x6) 31-030293-00 (Fibre)	HM5223 ■ (x2) 24-30020-00/0 (ACM)	HR397 [57] 34-000410-00		HR5062 ■ 24-30614-73/0	NA5001 (x2) 32x47x10mm, FPM (50-303185-50) NB716 ■ 35x48x10mm, FPM (50-306067-50)												 JD602		
																			 JE689	
																			 JJ184	
																			 JJ501	



KW/PS



A6 2.5L TDI Diesel 06/94 → 02/97 115						AF5310 (MLS), 1,51mm, 1 Hole 30-027510-40 AF5320 (MLS), 1,57mm, 2 Holes 30-027511-40 AF5330 (MLS), 1,61mm, 3 Holes 30-027512-40	DW860▲ 21-27504-20/0	EW860 (22-23856-07/0)
A6 2.5L TDI quattro Diesel 10/95 → 02/97								
A6 Avant 2.5L TDI Diesel 06/94 → 12/97								
A6 Avant 2.5L TDI quattro Diesel 07/95 → 12/97								
AAT	2461	5	81.00		85/116	AY060 (Fibre), 2.00mm (x2) 30-027222-20	DT660 21-27222-20/0 → Ch.4A-T-029 512 DY850 21-27222-21/0 Ch.4A-T-029 513 →	EY850 (22-28635-00/0) Ch.4A-S-026 715 →
AEL	2461	5	81.00		103/140			
A6 2.6L 06/94 → 02/97 116						AG8880 (MLS), 1.1mm, 1 Hole [87] 30-030240-00 AG8900 (MLS), 1.1mm, 1 Hole [88] 30-030242-00 AG8860 (MLS), 1.15mm, 2 Holes [87] 30-030219-00 AG8870 (MLS), 1.15mm, 2 Holes [88] 30-030220-00 AG8890 (MLS), 1.2mm, 3 Holes [87] 30-030241-00 AG8910 (MLS), 1.2mm, 3 Holes [88] 30-030243-00		
A6 2.6L quattro 06/94 → 02/97								
A6 Avant 2.6L 06/94 → 12/97								
A6 Avant 2.6L quattro 06/94 → 12/97								
ACZ	2598	6	82.50	SOHC, V6	102/139	AY060 (Fibre), 2.00mm (x2) 30-027222-20	DT660 21-27222-20/0 → Ch.4A-T-029 512 DY850 21-27222-21/0 Ch.4A-T-029 513 →	EY850 (22-28635-00/0) Ch.4A-S-026 715 →
ABC	2598	6	82.50	Injection, V6	110/150			
A6 Avant 2.7L TDI Diesel 03/05 → 117								
A6 2.7L TDI Diesel 11/04 →								
A6 2.7L TDI quattro Diesel 11/04 →								
A6 Avant 2.7L TDI quattro Diesel 03/05 →								
BSG	2698	6	81.40	Direct Injection, DOHC, V6	120/163	AG8860 (MLS), 1.15mm, 2 Holes [87] 30-030219-00 AG8870 (MLS), 1.15mm, 2 Holes [88] 30-030220-00 AG8890 (MLS), 1.2mm, 3 Holes [87] 30-030241-00 AG8910 (MLS), 1.2mm, 3 Holes [88] 30-030243-00		
BPP	2698	6	81.40	Direct Injection, DOHC, V6	132/180			
CANB	2698	6	83.00	DOHC, V6	120/163			
A6 2.8L 06/94 → 02/97 118								
A6 2.8L quattro 06/94 → 02/97								
A6 Avant 2.8L 06/94 → 12/97								
A6 Avant 2.8L quattro 06/94 → 12/97								
AEJ	2771	6	82.50	V6	120- 128/ 163- 174	AY060 (Fibre), 2.00mm (x2) 30-027222-20	DT660 21-27222-20/0 → Ch.4A-T-029 512 DY850 21-27222-21/0 Ch.4A-T-029 513 →	EY850 (22-28635-00/0) Ch.4A-S-026 715 →
AAH	2771	6	82.50	MH-Motronic, V6	128/174			
A6 3.0L TDI Diesel 06/06 → 119						AG8880 (MLS), 1.1mm, 1 Hole [87] 30-030240-00 AG8900 (MLS), 1.1mm, 1 Hole [88] 30-030242-00 AG8860 (MLS), 1.15mm, 2 Holes [87] 30-030219-00 AG8870 (MLS), 1.15mm, 2 Holes [88] 30-030220-00 AG8890 (MLS), 1.2mm, 3 Holes [87] 30-030241-00 AG8910 (MLS), 1.2mm, 3 Holes [88] 30-030243-00		
A6 Avant 3.0L TDi Diesel 06/06 →								
A6 3.0L TDI quattro Diesel 05/04 →								
A6 Avant 3.0L TDI quattro Diesel 03/05 →								
BNG	2967	6	83.00	Direct Injection, DOHC, V6	155/211	AC5960 (MLS), 1.10mm, 1 Hole (x2) 30-029397-00 AC5970 (MLS), 1.15mm, 2 Holes (x2) 30-029398-00 AC5980 (MLS), 1.20mm, 3 Holes (x2) 30-029399-00	CC5960▲ 21-29397-00/0	
CDYB	2967	6	83.00	Direct Injection	155/211			
BMK	2967	6	83.00	Direct Injection, DOHC, V6	165/224			
ASB	2967	6	83.00	Direct Injection, V6	171/232			
A8 2.5L TDI Diesel 09/00 → 09/02 120						AC5960 (MLS), 1.10mm, 1 Hole (x2) 30-029397-00 AC5970 (MLS), 1.15mm, 2 Holes (x2) 30-029398-00 AC5980 (MLS), 1.20mm, 3 Holes (x2) 30-029399-00	CC5960▲ 21-29397-00/0	
A8 2.5L TDI quattro Diesel 07/97 → 09/02								
AFB/AKN	2496	6	78.30	DOHC, V6	110/150			
AKE	2496	6	78.30	DOHC, V6	132/180			











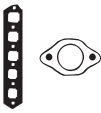

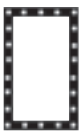

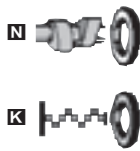



								 AC5960, AC5970, AC5980
HBS021  (22-39003B) M12x1.75x115mm (x12)	JD312  31-027043-00 JC152  (x5) 31-026555-00	JN967 50-027504-00	JJ184 (31-023856-10)	HR615  24-30667-05/0	NA5001 (x2) 32x47x10mm, FPM (50-303185-50) NB716  35x48x10mm, FPM (50-306067-50) NA5133  85x105x11mm, FPM (24-30727-87/0)			 AF5310  AF5320
HBS064  (22-39010B) M11x1.50x137mm (x16)		JM5166 (x2) 50-027936-00 (ACM) →Ch.4A-T-029 512	JH5118 (31-028635-00) Ch.4A-S-026 715→	HR569  (x2) 24-30667-00/0 →Ch.4A-T-029 512 HR602  24-30670-61/0 Ch.4A-T-029 513→	NA5001 (x3) 32x47x10mm, FPM (50-303185-50) NB716  35x48x10mm, FPM (50-306067-50) NA5133  85x105x11mm, FPM (24-30727-87/0)			 AF5330  AY060  JC152
HBS361  (22-33037B) M12x1.50x159mm (x16)	JD5872  (x2) 50-030355-00 (ACM)	JM7046 [87] 50-030356-00 (ACM) JM7047 [88] 50-030357-00 (ACM)	HR397 [57] 34-000410-00	HR5062  24-30614-73/0	NA5001 (x2) 32x47x10mm, FPM (50-303185-50)			 JD312  JN967  JJ184
HBS064  (22-39010B) M11x1.50x137mm (x16)		JM5166 (x2) 50-027936-00 (ACM) →Ch.4A-T-029 512	JH5118 (31-028635-00) Ch.4A-S-026 715→	HR569  (x2) 24-30667-00/0 →Ch.4A-T-029 512 HR602  24-30670-61/0 Ch.4A-T-029 513→	NA5001 (x3) 32x47x10mm, FPM (50-303185-50) NB716  35x48x10mm, FPM (50-306067-50) NA5133  85x105x11mm, FPM (24-30727-87/0)			
HBS361  (22-33037B) M12x1.50x159mm (x16)	JD5872  (x2) 50-030355-00 (ACM)	JM7046 [87] 50-030356-00 (ACM) JM7047 [88] 50-030357-00 (ACM)	HR397 [57] 34-000410-00	HR5062  24-30614-73/0	NA5001 (x2) 32x47x10mm, FPM (50-303185-50)			
HBS265  (22-33027B) M12x1.50x155mm (x16)	JD5810  (x2) (31-030230-00) JD5851  (x6) 31-030293-00 (Fibre)	HM5223  (x2) 24-30020-00/0 (ACM)		HR5062  24-30614-73/0	NA5001 (x2) 32x47x10mm, FPM (50-303185-50) NB716  35x48x10mm, FPM (50-306067-50)			

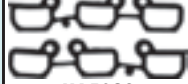

KW/PS



A8 2.5L TDI Diesel				01/97 → 04/00		121		AC5960 (MLS), 1.10mm, 1 Hole (x2) 30-029397-00 AC5970 (MLS), 1.15mm, 2 Holes (x2) 30-029398-00 AC5980 (MLS), 1.20mm, 3 Holes (x2) 30-029399-00		CC5960▲ 21-29397-00/0	
AFB/AKN	2496	6	78.30	DOHC, V6		110/150					
A8 2.8L A8 2.8L quattro				03/94 → 03/96		122		AY060 (Fibre), 2.00mm (x2) 30-027222-20		DT660 21-27222-20/0 → Ch.4D-T-003 800 DY850 21-27222-21/0 Ch.4D-T-003 801 →	
AEJ	2771	6	82.50	V6		120- 128/ 163- 174					EY850 [22-28635-00/0] Ch.4D-5-000 497 →
AAH	2771	6	82.50	MH-Motronic, V6		128/174					
A8 3.0L TDI quattro Diesel				08/03 →		123		AG8880 (MLS), 1.1mm, 1 Hole [87] 30-030240-00 AG8900 (MLS), 1.1mm, 1 Hole [88] 30-030242-00 AG8860 (MLS), 1.15mm, 2 Holes [87] 30-030219-00 AG8870 (MLS), 1.15mm, 2 Holes [88] 30-030220-00 AG8890 (MLS), 1.2mm, 3 Holes [87] 30-030241-00 AG8910 (MLS), 1.2mm, 3 Holes [88] 30-030243-00			
BNG	2967	6	83.00	Direct Injection, DOHC, V6		155/211					
ASB	2967	6	83.00	Direct Injection, V6		171/232					
Allroad 2.5L TDI quattro Diesel				05/00 → 08/05		124		AC5960 (MLS), 1.10mm, 1 Hole (x2) 30-029397-00 AC5970 (MLS), 1.15mm, 2 Holes (x2) 30-029398-00 AC5980 (MLS), 1.20mm, 3 Holes (x2) 30-029399-00		CC5960▲ 21-29397-00/0	
AKE/BAU	2496	6	78.30	DOHC, V6		132/180					
Allroad 2.5L TDI quattro Diesel				05/03 → 08/05		125		AC5960 (MLS), 1.10mm, 1 Hole (x2) 30-029397-00 AC5970 (MLS), 1.15mm, 2 Holes (x2) 30-029398-00 AC5980 (MLS), 1.20mm, 3 Holes (x2) 30-029399-00		CC5960▲ 21-29397-00/0	
BCZ	2496	6	78.30	DOHC, V6		120/163					
Cabriolet Convertible 1.8L				01/97 → 08/00		126		AY970 (MLS) 30-028495-00		CY970 21-28495-20/0 EY840 22-28825-00/0	
ADR	1781	4	81.00	Injection, DOHC		92/125					

								
HBS265 Ⓢ [22-33027B] M12x1.50x155mm (x16)	JD5810 ■ (x2) [31-030230-00] JD5851 ■ (x6) 31-030293-00 (Fibre)	HM5223 ■ (x2) 24-30020-00/0 (ACM)		HR5062 ■ 24-30614-73/0	NA5001 (x2) 32x47x10mm, FPM [50-303185-50] NB716 ■ 35x48x10mm, FPM [50-306067-50]			 AC5310  AC5960, AC5970, AC5980  AY060  AY970  BT680  HA5023  JD492  JD497  JD604  JD605  JF191  JJ610  JJ611
HBS064 Ⓢ [22-39010B] M11x1.50x137mm (x16)		JM5166 (x2) 50-027936-00 (ACM) →Ch.4D-T-003 800	JH5118 [31-028635-00] Ch.4D-S-000 497→	HR602 ■ 24-30670-61/0	NA5001 (x3) 32x47x10mm, FPM [50-303185-50] NB716 ■ 35x48x10mm, FPM [50-306067-50] NA5133 ■ 85x105x11mm, FPM [24-30727-87/0]			
HBS361 Ⓢ [22-33037B] M12x1.50x159mm (x16)	JD5872 ■ (x2) 50-030355-00 (ACM)	JM7046 [87] 50-030356-00 (ACM) JM7047 [88] 50-030357-00 (ACM)	HR397 [57] 34-000410-00	HR5062 ■ 24-30614-73/0	NA5001 (x2) 32x47x10mm, FPM [50-303185-50]			
HBS265 Ⓢ [22-33027B] M12x1.50x155mm (x16) AKE HBS361 Ⓢ [22-33037B] M12x1.50x159mm (x16) BAU	JD5810 ■ (x2) [31-030230-00] JD5851 ■ (x6) 31-030293-00 (Fibre)	HM5223 ■ (x2) 24-30020-00/0 (ACM)	HR397 [57] 34-000410-00 BAU	HR5062 ■ 24-30614-73/0	NA5001 (x2) 32x47x10mm, FPM [50-303185-50] NB716 ■ 35x48x10mm, FPM [50-306067-50]			
HBS361 Ⓢ [22-33037B] M12x1.50x159mm (x16)	JD5810 ■ (x2) [31-030230-00] JD5851 ■ (x6) 31-030293-00 (Fibre)	HM5223 ■ (x2) 24-30020-00/0 (ACM)	HR397 [57] 34-000410-00 BAU	HR5062 ■ 24-30614-73/0	NA5001 (x2) 32x47x10mm, FPM [50-303185-50] NB716 ■ 35x48x10mm, FPM [50-306067-50]			
HBS171 Ⓢ [22-39027B] M11x1.50x101mm (x10)	JD604 ■ [31-028824-00] JD605 ■ 31-028826-00	HL732 ■ 24-28815-00/0	JJ610 [50-028825-00]	HR822 ■	NA5001 32x47x10mm, FPM [50-303185-50] NA5001 ■ 32x47x10mm, FPM [50-303185-50] NA5133 ■ 85x105x11mm, FPM [24-30727-87/0] LK5006 ■ [3] 85x131x16mm, PTFE [50-319448-00]	HL5020 [245]■		











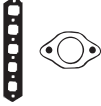

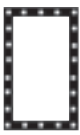

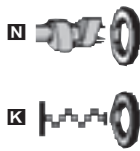

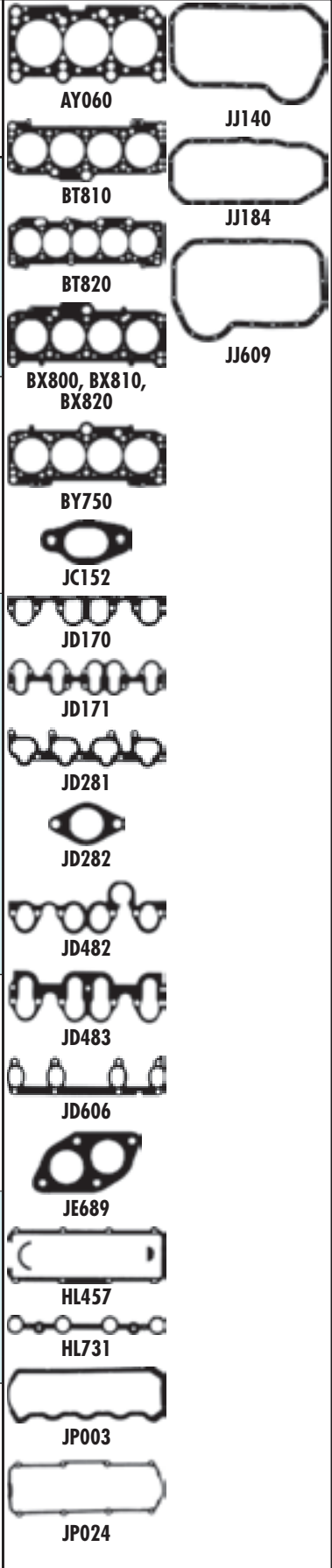

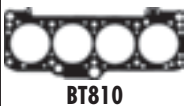







AUDI

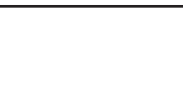

KW/PS



Cabriolet Convertible 1.9L TDI Diesel		06/95 → 08/00		127				
1Z/AHU	1896	4	79.50		66/89	BX800 (MLS), 1.45mm, 1 Hole 30-028686-00 BX810 (MLS), 1.53mm, 2 Holes 30-028687-00 BX820 (MLS), 1.61mm, 3 Holes 30-028688-00	DX800 ▲ 21-27921-20/0 → Eng. 1Z 770 000 DX801 ▲ 21-27921-21/0 Eng. 1Z 770 001 → AHU	EC30 [8] 22-26384-04/0
Cabriolet Convertible 2.0L 16V		06/95 → 07/96		128				
ACE	1984	4	82.50	KE-Motronic	103/140	BY750 (MLS) 30-027930-00	DY751 21-27930-24/0 → Eng. ACE 017 542 DY752 21-27930-25/0 Eng. ACE 017 543 →	EB970 22-27500-01/0
Cabriolet Convertible 2.0L E		01/93 → 07/98		129				
ABK	1984	4	82.50	Digifant	85/116	BT810 (Fibre) 30-027257-20 → Ch. 8G-S-009 000 BY750 (MLS) 30-027930-00 Ch. 8G-S-009 001 →	DT814 21-26470-20/0 → Ch. 8G-P-006 500 DT81C 21-27257-26/0 Ch. 8G-P-006 501 → → Ch. 8G-S-009 000 DY750 21-27930-40/0 Ch. 8G-S-009 001 →	EB970 22-27500-01/0
Cabriolet Convertible 2.3L E		05/91 → 07/94		130				
NG	2309	5	82.50	SOHC	98-100/ 133- 136	BT820 (Fibre)	DT820 21-26082-21/0	EX995 (22-23856-06/0)
Cabriolet Convertible 2.6L		06/93 → 08/00		131				
ACZ ABC	2598 2598	6 6	82.50 82.50	SOHC, V6 Injection, V6	102/139 110/150	AY060 (Fibre), 2.00mm (x2) 30-027222-20	DT660 21-27222-20/0 → Ch. 8G-T-004 318 DY850 21-27222-21/0 Ch. 8G-T-004 319 →	EY850 (22-28635-00/0) Ch. 8G-S-001 303 →
Cabriolet Convertible 2.8L		11/92 → 08/00		132				
AAH	2771	6	82.50	MH-Motronic, V6	128/174	AY060 (Fibre), 2.00mm (x2) 30-027222-20	DT660 21-27222-20/0 → Ch. 8G-T-004 318 DY850 21-27222-21/0 Ch. 8G-T-004 319 →	EY850 (22-28635-00/0) Ch. 8G-S-001 303 →

								
HBS018 Ⓞ (22-39024B) M12x1.75x115mm (x10)	JD170 ■ 31-026556-10 JC152 ■ (x4) 31-026555-00	JP003 50-027921-00	JJ609 (50-027500-00) (ACM)	HR569 ■ 24-30667-00/0 →Eng.1Z 770 000 HR816 ■ 24-30653-85/0 Eng.1Z 770 001→	NA5001 32x47x10mm, FPM (50-303185-50) NA5001 ■ 32x47x10mm, FPM (50-303185-50) NA5133 ■ 85x105x11mm, FPM (24-30727-87/0)	HL5020 [245]■	 AY060  BT810  BT820  BX800, BX810, BX820  BY750  JC152  JD170  JD171  JD281  JD282  JD482  JD483  JD606  JE689  HL457  HL731  JP003  JP024  JJ140  JJ184  JJ609	
HBS028 Ⓞ (22-39004B) M11x1.50x147mm (x10)	JD281 ■ (31-027904-00) JD282 ■ (x4) (31-026880-00) JE689 (31-024039-00)	HL606 ■ 24-26237-01/0 →Eng.ACE 017 542 HL731 ■ 24-27937-00/0 Eng.ACE 017 543→		HR816 ■ (x2) 24-30653-85/0	NA5001 32x47x10mm, FPM (50-303185-50) NA5001 ■ 32x47x10mm, FPM (50-303185-50) NA5133 ■ 85x105x11mm, FPM (24-30727-87/0)	HL5020 [245]■		
HBS043 Ⓞ (22-39001B) M11x1.50x95mm (x10) →Ch.8G-S-009 000	JD482 ■ (31-027351-00) JD483 ■ (31-027352-00) JC152 ■ (x4) 31-026555-00 JD606 ■ (31-028918-00) JE689 (31-024039-00)	JP024 50-027505-00 Ch.8G-P-006 501→ HL457 ■ [79] 24-25753-01/0 (Cork) →Ch.8G-P-006 500 HM5053 ■ [80] 24-28543-00/0 (ACM) →Ch.8G-P-006 500	JJ140 (31-026554-10)	HR569 ■ 24-30667-00/0 →Eng.ABK 245 263 HR816 ■ 24-30653-85/0 Eng.ABK 245 264→	NA5001 32x47x10mm, FPM (50-303185-50) NA5001 ■ 32x47x10mm, FPM (50-303185-50) NA5133 ■ 85x105x11mm, FPM (24-30727-87/0)	HL5020 [245]■		
HBS024 Ⓞ (22-39002B) M11x1.50x95mm (x12)	JD171 ■■ 31-027048-00 JD327 ■■ (31-026472-00) JC152 ■ (x5) 31-026555-00 JE689 (31-024039-00)		JJ184 (31-023856-10)	HR615 ■ 24-30667-05/0	NA5001 32x47x10mm, FPM (50-303185-50) NB716 ■ 35x48x10mm, FPM (50-306067-50) NA5133 ■ 85x105x11mm, FPM (24-30727-87/0)			
HBS064 Ⓞ (22-39010B) M11x1.50x137mm (x16)		JM5166 (x2) 50-027936-00 (ACM) →Ch.8G-T-004 318	JH5118 (31-028635-00) Ch.8G-S-001 303→	HR805 ■ →Ch.8G-T-004 318 HR5068 ■ (x2) (24-30653-84/0) Ch.8G-T-004 319→	NA5001 (x3) 32x47x10mm, FPM (50-303185-50) NB716 ■ 35x48x10mm, FPM (50-306067-50) NA5133 ■ 85x105x11mm, FPM (24-30727-87/0)			
HBS064 Ⓞ (22-39010B) M11x1.50x137mm (x16)		JM5166 (x2) 50-027936-00 (ACM) →Ch.8G-T-004 318	JH5118 (31-028635-00) Ch.8G-S-001 303→	HR805 ■ →Ch.8G-T-004 318 HR5068 ■ (x2) (24-30653-84/0) Ch.8G-T-004 319→	NA5001 (x3) 32x47x10mm, FPM (50-303185-50) NB716 ■ 35x48x10mm, FPM (50-306067-50) NA5133 ■ 85x105x11mm, FPM (24-30727-87/0)			











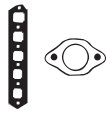

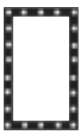

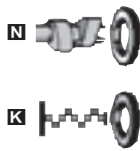



AUDI



KW/PS



Coupe 1.8L					08/81 → 07/83	133	BM360 (Fibre)	DM360	EG873
Coupe 1.8L GT					09/82 → 10/88		30-026807-30	21-26807-24/0	
DD	1781	4	81.00		55/75				
DS/IV	1781	4	81.00		66/89				
Coupe 1.8L					08/89 → 07/91	134	BM360 (Fibre)	DM363 [83]	EG873
Coupe 1.8L GT					08/86 → 10/88		30-026807-30	21-26807-27/0	
Coupe 1.8L GT quattro					12/84 → 10/88				
DZ	1781	4	81.00		82/111				
Coupe 1.8L GT					04/86 → 10/88	135	BM360 (Fibre)	DM363 [83]	EG873
SF	1781	4	81.00		64/87	30-026807-30	21-26807-27/0		
Coupe 1.8L GT					01/85 → 07/88	136	BM360 (Fibre)	DM361 [83]	EG873
JN	1781	4	81.00	SOHC	66/89	30-026807-30	21-26807-22/0		
PV	1781	4	81.00	SOHC	82/111				
Coupe 1.8L GT quattro					09/85 → 10/88	137	BM360 (Fibre)	DM360	EG873
DS	1781	4	81.00		66/89	30-026807-30	21-26807-24/0		
JN/NE	1781	4	81.00	SOHC	66/89		DS		
							DM361 [83]		
							21-26807-22/0		
							JN		
							DM363 [83]		
							21-26807-27/0		
							NE		
Coupe 2.0L					09/83 → 04/88	138	BM840 (Fibre)	DM840	EX995
HP/JS/SK	1994	5	81.00		85/116	30-026326-10	(21-26326-22/0)	(22-23856-06/0)	











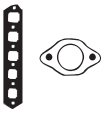

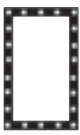

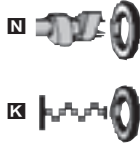





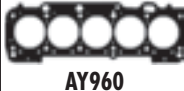
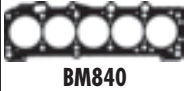













































								 BM360
HBS043 Ⓢ (22-39001B) M11x1.50x95mm (x10)	JC478 ■ 31-026397-00 PA459 ■ 50-024870-00 (NBR) JC152 ■ (x4) 31-026555-00 Ⓢ JE138 (31-024515-00) Ⓢ JE904 (31-023715-00)	HL457 ■ [79] 24-25753-01/0 (Cork) HM5053 ■ [80] 24-28543-00/0 (ACM)	JJ140 (31-026554-10)	HR569 ■ 24-30667-00/0	NA5001 32x47x10mm, FPM (50-303185-50) NA5001 ■ 32x47x10mm, FPM (50-303185-50) NA5133 ■ 85x105x11mm, FPM (24-30727-87/0)	HL5020 [245]■ KA5020 [13]	 BM840  JC152  JC261  JC478  JE689  JE904  PA459	
HBS043 Ⓢ (22-39001B) M11x1.50x95mm (x10)	JC478 ■ 31-026397-00 JC152 ■ (x4) 31-026555-00	HL457 ■ [79] 24-25753-01/0 (Cork) HM5053 ■ [80] 24-28543-00/0 (ACM)	JJ140 (31-026554-10)	HR569 ■ 24-30667-00/0	NA5001 32x47x10mm, FPM (50-303185-50) NA5001 ■ 32x47x10mm, FPM (50-303185-50) NA5133 ■ 85x105x11mm, FPM (24-30727-87/0)	HL5020 [245]■	 HL457  HL460	
HBS043 Ⓢ (22-39001B) M11x1.50x95mm (x10)	JC478 ■ 31-026397-00 JC152 ■ (x4) 31-026555-00 Ⓢ JE138 (31-024515-00)	HL457 ■ [79] 24-25753-01/0 (Cork) HM5053 ■ [80] 24-28543-00/0 (ACM)	JJ140 (31-026554-10)	HR569 ■ 24-30667-00/0	NA5001 32x47x10mm, FPM (50-303185-50) NA5001 ■ 32x47x10mm, FPM (50-303185-50) NA5133 ■ 85x105x11mm, FPM (24-30727-87/0)	HL5020 [245]■ KA5020 [13]	 JJ140  JJ184	
HBS043 Ⓢ (22-39001B) M11x1.50x95mm (x10)	JC478 ■ 31-026397-00 PA459 ■ 50-024870-00 (NBR) JC152 ■ (x4) 31-026555-00 Ⓢ JE138 (31-024515-00) JN Ⓢ JE689 (31-024039-00) NE Ⓢ JE904 (31-023715-00) DS	HL457 ■ [79] 24-25753-01/0 (Cork) HM5053 ■ [80] 24-28543-00/0 (ACM)	JJ140 (31-026554-10)	HR569 ■ 24-30667-00/0	NA5001 32x47x10mm, FPM (50-303185-50) NA5001 ■ 32x47x10mm, FPM (50-303185-50) NA5133 ■ 85x105x11mm, FPM (24-30727-87/0)	HL5020 [245]■ KA5020 [13]		
HBS024 Ⓢ (22-39002B) M11x1.50x95mm (x12)	JC261 ■ (31-026898-00) JC152 ■ (x5) 31-026555-00 Ⓢ JE689 (31-024039-00)	HL460 ■ (Cork) HM5277 ■ 24-26864-00/0 (Rubber)	JJ184 (31-023856-10)	HR615 ■ 24-30667-05/0	NA5001 32x47x10mm, FPM (50-303185-50) NB716 ■ 35x48x10mm, FPM (50-306067-50) NA5133 ■ 85x105x11mm, FPM (24-30727-87/0)			

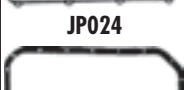

KW/PS



Coupe 2.0L					05/89 → 12/96	139	BT810 (Fibre)	DT814	EB970
AAD	1984	4	82.50	K-Motronic	85/116	30-027257-20	21-26470-20/0 → Ch.8B-P-006 500	22-27500-01/0	
ABK	1984	4	82.50	Digifant	85/116		DT81C 21-27257-26/0 Ch.8B-P-006 501 → → Ch.8B-S-009 000	ABK ES471 AAD	
Coupe 2.0L					05/89 → 07/90	140	BT810 (Fibre)	DT813	EB970
3A	1984	4	82.50	K-Motronic	83/113	30-027257-20	21-27257-20/0	22-27500-01/0	
Coupe 2.0L 16 V					01/92 → 07/92	141	BY750 (MLS)	DY751	ES471
6A	1984	4	82.50	KE-Motronic	101/137	30-027930-00	21-27930-24/0		
Coupe 2.0L 16 V					08/92 → 12/96	142	BY750 (MLS)	DY751	
ACE	1984	4	82.50	KE-Motronic	103/140	30-027930-00	21-27930-24/0 → Eng.ACE 017 542	DY752 21-27930-25/0 Eng.ACE 017 543 →	
Coupe 2.0L 20 V					08/89 → 07/91	143	AY960 (MLS)	CY960	EC010
Coupe 2.0L 20 V quattro					08/89 → 07/91		30-028016-00	21-28016-20/0	(22-26274-00/0)
NM	1994	5	81.00		118/160				
Coupe 2.2L GT					07/81 → 10/88	144	BM840 (Fibre)	DM840	EX995
Coupe 2.2L quattro					10/84 → 07/91		30-026326-10	(21-26326-22/0)	(22-23856-06/0)
HY	2144	5	81.00		100/136				
KX	2226	5	81.00		85/116				
JT	2226	5	81.00		88/120				
KV	2226	5	81.00		100/136				
Coupe 2.2L S2 quattro					09/90 → 12/96	145	AY960 (MLS)	CY960	EC010
3B	2226	5	81.00		162/220	30-028016-00	21-28016-20/0	(22-26274-00/0)	
ABY	2226	5	81.00		169/230				











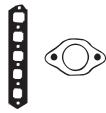

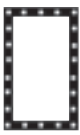

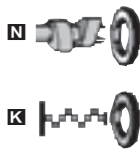















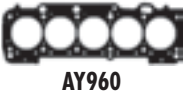













































								
HBS043 Ⓢ [22-39001B] M11x1.50x95mm (x10) →Ch.8B-S-009 000	JD482 ■ (31-027351-00) JD483 ■ (31-027352-00) JC152 ■ (x4) 31-026555-00 JD606 ■ (31-028918-00)  JE689 (31-024039-00)	JP024 50-027505-00 Ch.8B-P-006 501→ HL457 ■ [79] 24-25753-01/0 (Cork) →Ch.8B-P-006 500 HM5053 ■ [80] 24-28543-00/0 (ACM) →Ch.8B-P-006 500	JJ140 (31-026554-10)	HR569 ■ 24-30667-00/0 →Eng.ABK 245 263 AAD HR816 ■ 24-30653-85/0 Eng.ABK 245 264→	 NA5001 32x47x10mm, FPM (50-303185-50)  NA5001 32x47x10mm, FPM (50-303185-50)  NA5133 85x105x11mm, FPM (24-30727-87/0)	HL5020 [245]■	 AY960  BM840  BT810  BY750  JC152  JC261  JD281  JD282  JD482  JD483  JD602  JD606  JE689  HL457  HL460  HL731  JP024  JJ140	
HBS043 Ⓢ [22-39001B] M11x1.50x95mm (x10)	JC152 ■ (x4) 31-026555-00  JE689 (31-024039-00)	HL457 ■ [79] 24-25753-01/0 (Cork) HM5053 ■ [80] 24-28543-00/0 (ACM)	JJ140 (31-026554-10)	HR569 ■ 24-30667-00/0	 NA5001 32x47x10mm, FPM (50-303185-50)  NA5001 32x47x10mm, FPM (50-303185-50)  NA5133 85x105x11mm, FPM (24-30727-87/0)	HL5020 [245]■	 JD281  JD282  JD482  JD483  JD602  JD606  JE689	
	JD281 ■ (31-027904-00) JD282 ■ (x4) (31-026880-00)	HL606 ■ 24-26237-01/0	JJ140 (31-026554-10)	HR816 ■ (x2) 24-30653-85/0	 NA5001 32x47x10mm, FPM (50-303185-50)  NA5001 32x47x10mm, FPM (50-303185-50)  NA5133 85x105x11mm, FPM (24-30727-87/0)	HL5020 [245]■	 JD482  JD483  JD602  JD606  JE689	
	JD281 ■ (31-027904-00) JD282 ■ (x4) (31-026880-00)  JE689 (31-024039-00)	HL606 ■ 24-26237-01/0 →Eng.ACE 017 542 HL731 ■ 24-27937-00/0 Eng.ACE 017 543→		HR816 ■ (x2) 24-30653-85/0	 NA5001 32x47x10mm, FPM (50-303185-50)  NA5001 32x47x10mm, FPM (50-303185-50)  NA5133 85x105x11mm, FPM (24-30727-87/0)	HL5020 [245]■	 JD602  JD606  JE689	
HBS269 Ⓢ [22-33032B] M11x1.50x141.5mm (x12)	JD602 ■ (31-026277-00) JD282 ■ (x5) (31-026880-00)	HL730 ■ 24-27424-00/0	JJ501 (31-027042-00)		 NA5001 32x47x10mm, FPM (50-303185-50)  NB716 35x48x10mm, FPM (50-306067-50)  NA5133 85x105x11mm, FPM (24-30727-87/0)		 HL457  HL460  HL731  JP024	
HBS024 Ⓢ [22-39002B] M11x1.50x95mm (x12)	JC261 ■ (31-026898-00) JC152 ■ (x5) 31-026555-00	HL460 ■ (Cork) HM5277 ■ 24-26864-00/0 (Rubber)	JJ184 (31-023856-10)	HR615 ■ 24-30667-05/0	 NA5001 32x47x10mm, FPM (50-303185-50)  NB716 35x48x10mm, FPM (50-306067-50)  NA5133 85x105x11mm, FPM (24-30727-87/0)		 JP024	
HBS269 Ⓢ [22-33032B] M11x1.50x141.5mm (x12)	JD602 ■ (31-026277-00) JD282 ■ (x5) (31-026880-00) JD603 ■ (31-027514-00)	HL730 ■ 24-27424-00/0	JJ501 (31-027042-00)		 NA5001 32x47x10mm, FPM (50-303185-50)  NB716 35x48x10mm, FPM (50-306067-50)  NA5133 85x105x11mm, FPM (24-30727-87/0)		 JJ140	



KW/PS



Coupe 2.3L		01/87 → 12/96			146	BT820 (Fibre)	DT820 21-26082-21/0 Ch.88-L-014 001→	EX995 (22-23856-06/0)
Coupe 2.3L quattro		01/87 → 12/96						
NG	2309	5	82.50	SOHC	98-100/ 133- 136			
Coupe 2.6L		08/92 → 12/96			147	AY060 (Fibre), 2.00mm (x2) 30-027222-20	DT660 21-27222-20/0 → Ch.88-T-002 000 DY850 21-27222-21/0 Ch.88-T-002 001→	EY850 (22-28635-00/0) Ch.88-S-000 545→
Coupe 2.6L quattro		08/92 → 12/96						
ABC	2598	6	82.50	Injection, V6	110/150			
Coupe 2.8L		09/91 → 12/96			148	AY060 (Fibre), 2.00mm (x2) 30-027222-20	DT660 21-27222-20/0 → Ch.88-T-002 000 DY850 21-27222-21/0 Ch.88-T-002 001→	EY850 (22-28635-00/0) Ch.88-S-000 545→
Coupe 2.8L quattro		08/91 → 12/96						
AAH	2771	6	82.50	MH-Motronic, V6	128/174			
Q7 3.0L TDI quattro Diesel		03/06 →			149	AG8880 (MLS), 1.1mm, 1 Hole [87] 30-030240-00 AG8900 (MLS), 1.1mm, 1 Hole [88] 30-030242-00 AG8860 (MLS), 1.15mm, 2 Holes [87] 30-030219-00 AG8870 (MLS), 1.15mm, 2 Holes [88] 30-030220-00 AG8890 (MLS), 1.2mm, 3 Holes [87] 30-030241-00 AG8910 (MLS), 1.2mm, 3 Holes [88] 30-030243-00		
CASB	2967	6	83.00	Direct Injection, DOHC, V6	155/211			
BUG	2967	6	83.00	Direct Injection, DOHC, V6	171/233			
BUN	2967	6	83.00	Direct Injection, DOHC, V6				
Quattro Coupe 2.1L Turbo		07/80 → 07/87			150	BD620 (Fibre) 30-024697-10	DD622 GV	EX995 (22-23856-06/0)
GV/WR	2144	5	79.50		147/200			
Quattro Coupe 2.2L 20V		08/89 → 07/91			151	AY960 (MLS) 30-028016-00	CY960 21-28016-20/0	ECO10 (22-26274-00/0)
RR	2226	5	81.00		162/220			
Quattro Coupe 2.2L Turbo		08/87 → 07/89			152	BM840 (Fibre) 30-026326-10		EX995 (22-23856-06/0)
TB/MB	2226	5	81.00		147/200			











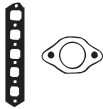

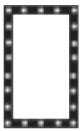



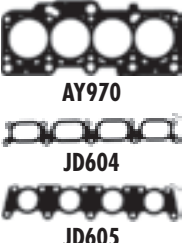

								
HBS024 Ⓢ (22-39002B) M11x1.50x95mm (x12)	JD327   (31-026472-00) JD171   31-027048-00 JC152  (x5) 31-026555-00  JE689 (31-024039-00)	JN438 (50-026864-00) (Rubber) →Ch.8B-L-014 000 HMS277  24-26864-00/0 (Rubber) →Ch.8B-L-014 000	JJ184 (31-023856-10)	HR615  24-30667-05/0	 NA5001 32x47x10mm, FPM (50-303185-50)  NB716  35x48x10mm, FPM (50-306067-50)  NA5133  85x105x11mm, FPM (24-30727-87/0)		 AY060  AY960  BD620  BM840  BT820  JC152  JC261  JD171  JD282  JD602  JE689  HL460  JJ184  JJ501	
HBS064 Ⓢ (22-39010B) M11x1.50x137mm (x16)		JM5166 (x2) 50-027936-00 (ACM) →Ch.8B-T-002 000	JH5118 (31-028635-00) Ch.8B-S-000 545→	HR805  →Ch.8B-T-002 000 HR602  24-30670-61/0 Ch.8B-T-002 001→	 NA5001 (x3) 32x47x10mm, FPM (50-303185-50)  NB716  35x48x10mm, FPM (50-306067-50)  NA5133  85x105x11mm, FPM (24-30727-87/0)			
HBS064 Ⓢ (22-39010B) M11x1.50x137mm (x16)		JM5166 (x2) 50-027936-00 (ACM) →Ch.8B-T-002 000	JH5118 (31-028635-00) Ch.8B-S-000 545→	HR805  →Ch.8B-T-002 000 HR602  24-30670-61/0 Ch.8B-T-002 001→	 NA5001 (x3) 32x47x10mm, FPM (50-303185-50)  NB716  35x48x10mm, FPM (50-306067-50)  NA5133  85x105x11mm, FPM (24-30727-87/0)			
HBS361 Ⓢ (22-33037B) M12x1.50x159mm (x16)	JD5872  (x2) 50-030355-00 (ACM)	JM7046 [87] 50-030356-00 (ACM) JM7047 [88] 50-030357-00 (ACM)	HR397 [57] 34-000410-00	HR5062  24-30614-73/0	 NA5001 (x2) 32x47x10mm, FPM (50-303185-50)			
HBS024 Ⓢ (22-39002B) M11x1.50x95mm (x12) GV	JC261  (31-026898-00) JC152  (x5) 31-026555-00	HL460  (Cork) GV	JJ184 (31-023856-10)	HR615  24-30667-05/0	 NA5001 32x47x10mm, FPM (50-303185-50)  NB716  35x48x10mm, FPM (50-306067-50)  NA5133  85x105x11mm, FPM (24-30727-87/0)			
HBS269 Ⓢ (22-33032B) M11x1.50x141.5mm (x12)	JD602  (31-026277-00) JD282  (x5) (31-026880-00) JD603  (31-027514-00)	HL730  24-27424-00/0	JJ501 (31-027042-00)		 NA5001 32x47x10mm, FPM (50-303185-50)  NB716  35x48x10mm, FPM (50-306067-50)  NA5133  85x105x11mm, FPM (24-30727-87/0)			
HBS024 Ⓢ (22-39002B) M11x1.50x95mm (x12)	JC261  (31-026898-00) JC152  (x5) 31-026555-00	HL460  (Cork)	JJ184 (31-023856-10)	HR615  24-30667-05/0	 NA5001 32x47x10mm, FPM (50-303185-50)  NB716  35x48x10mm, FPM (50-306067-50)  NA5133  85x105x11mm, FPM (24-30727-87/0)			



KW/PS



TT 1.8L T						10/99 →	153	AY970 (MLS) 30-028495-00	CY971 21-28495-21/0	EY841 22-28897-02/0
TT 1.8L T quattro						10/99 →				
TT Coupe 1.8L T						10/98 →				
TT Coupe 1.8L T quattro						10/98 →				
AUM	1781	4	81.00	DOHC		110/150				
BVP	1781	4	81.00	DOHC		120/163				
APX	1781	4	81.00	DOHC		121/ 162/ 165/ 221				
AJQ/APP/ARY	1781	4	81.00	DOHC		132/180				
ATC	1781	4	81.00	Injection, DOHC		132/180				
AUQ	1781	4	81.00	DOHC		132/180				
AWP	1781	4	81.00	Injection, DOHC		132/180				
BVR	1781	4	81.00	DOHC		140/190				
AMU	1781	4	81.00	Injection, DOHC		165/224				
BAM	1781	4	81.00	DOHC		165/224				
BFV	1781	4	81.00	Injection, DOHC						
TT 3.2L V6 quattro						10/06 →	154	AG9610 (MLS) 30-030350-00	CG9610 21-30350-00/0	
TT 3.2L VR6 quattro						07/03 →				
BHE	3189	6	84.00	DOHC, V6		184/250				
BPF/BUB	3189	6	84.00	Injection, DOHC, V6		184/250				

								
HBS268  (22-33031B) M10x1.50x120mm (x10)	JD604  (31-028824-00) JD605  31-028826-00	HL732  24-28815-00/0	HR397 [57] 34-000410-00 JH5117 (50-030046-00)	HR822 	NA5124 (x2) 32x47x10mm, PTFE (50-319433-00) NA5106  35x48x10mm, PTFE (50-319430-00) LK5003  [3] 85x131x15.7mm, PTFE (50-319434-00)	HL5040 [245] 		
HBS466 (22-33039B)	JD5874  50-030351-00 (FPM)	JM7045 50-030133-00 (Rubber)	HR397 [57] 34-000410-00	HR5062 	NA5106  35x48x10mm, PTFE (50-319430-00)			



CC



9



CC



9

10 HA	Petrol	1098	4	64.56	23
12 HA85AA	Petrol	1275	4	70.61	14
12CC	Petrol	1275	4	70.61	5
12H (A+ Series)	Petrol	1275	4	70.61	1
16 H (S Series)	Petrol	1598	4	76.20	28
16 H (S Series)	Petrol	1598	4	76.20	8
19 J	Diesel	2495	4	90.47	16
20 H (O Series)	Petrol	1994	4	84.44	29
20 HA50AA	Petrol	1994	4	84.44	9
20 HC51AA	Petrol	1994	4	84.44	9
20 HC81	Petrol	1994	4	84.44	9
A + series (99H)	Petrol	998	4	64.56	11
A Series	Petrol	848	4	62.92	17
A Series	Petrol	848	4	62.92	18
A Series	Petrol	970	4	70.62	22
A Series	Petrol	998	4	64.56	19
A Series	Petrol	998	4	64.56	21
A Series	Petrol	1071	4	70.62	24
A Series	Petrol	1275	4	70.61	25
A Series	Petrol	1275	4	70.62	26
A series (10H)	Petrol	1098	4	64.56	23
A Series (12 H)	Petrol	1275	4	70.61	12
A Series (12 H)	Petrol	1275	4	70.61	13
A Series (12 H)	Petrol	1275	4	70.61	7
A+ Series	Petrol	998	4	64.56	10
A+ Series	Petrol	1275	4	70.62	15
A+ Series (12 H)	Petrol	1275	4	70.61	12
A+ Series (12 H996)	Petrol	1275	4	70.61	13
A+ Series (12 H999)	Petrol	1275	4	70.61	7
A+ Series (12 HA)	Petrol	1275	4	70.61	13
A+ Series (12 HC)	Petrol	1275	4	70.61	7
A+ Series (12 HL)	Petrol	1275	4	70.61	12
A+ Series (12 HL)	Petrol	1275	4	70.61	27
A+ Series (99H)	Petrol	998	4	64.56	10
A+ Series (99H)	Petrol	998	4	64.56	20
O Series	Petrol	1695	4	84.44	2
O Series	Petrol	1695	4	84.44	30
O Series	Petrol	1994	4	84.44	3
O Series	Petrol	1994	4	84.44	31
O Series (20H)	Petrol	1994	4	84.44	29
O Series (20HSC)	Petrol	1994	4	84.44	29











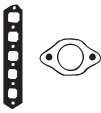

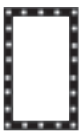

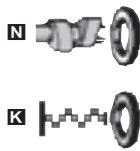







AUSTIN



KWPS



Allegro 1.3L				01/79 → 10/83	1	AF470 (Fibre) [122] (30-027571-00) BK450 (Fibre) [123]	CF474 [122] DK450 [123]	EF464 [124]
12H (A+ Series)	1275	4	70.61		46/63			
Ambassador 1.7L				03/82 → 02/84	2	BD970 (Fibre)		
0 Series	1695	4	84.44		62/84			
Ambassador 2.0L				03/82 → 10/84	3	BD970 (Fibre)		
0 Series	1994	4	84.44		69/94			
Healey Sprite Mk.III				03/64 → 09/66	4	AF070 (Fibre) [121] (30-027570-00)	CF070 [122]	EF070 → Eng.10CC/H37548 → Eng.10CC/L25599 EF074 Eng.10CC/25600; 9C→ Eng.10CC/H37549→
	1098	4			41/56			
Healey Sprite Mk.IV				03/66 → 10/71	5	AF460 (Fibre) [121] (30-027582-00) AF470 (Fibre) [122] (30-027571-00) BK450 (Fibre) [123]	CF463 [121] CF473 [122]	EF460
12CC	1275	4	70.61		48/65			
Healey 3000 Sport Mk.III				03/64 → 10/68	6	AD890 (Fibre)	CD891 [122]	ED890 [12]
	2912	6			110/150			
Maestro 1.3L				03/83 → 08/85	7	AF470 (Fibre) [122] (30-027571-00) BK450 (Fibre) [123]	CF474 [122] DK450 [123]	EK451
Maestro 1.3L LS				03/83 → 08/90				
A Series (12 H)	1275	4	70.61	OHV	40-49/ 54-67			
A+ Series (12 H999)/HC	1275	4	70.61	OHV	46/63			
Maestro Mayfair HLS				03/83 → 08/90	8	BL380 (Fibre)		
16 H (S Series)	1598	4	76.20	Injection, SOHC	61/82			
Maestro 2.0L EFI				10/84 → 08/90	9	BN670 (Fibre)	DN671 01/86 → 12/88 DN676 01/88 →	EM684 1986 →
20 HA50AA/ 20 HC51AA/20 HC81	1994	4	84.44	Injection, SOHC	83/113			
Metro 1.0L				10/80 → 04/90	10	AF070 (Fibre) [121] (30-027570-00)	CF073 [122]	EF07C [124]
A+ Series (99H)	998	4	64.56	OHV	29-33/ 39-45			
A+ Series	998	4	64.56		30/41			
Metro 1.0L Surf HLE				10/80 → 04/90	11	AF070 (Fibre) [121] (30-027570-00)	CF073 [122]	
A + series (99H)	998	4	64.56	OHV	35/48			
Metro 1.3L				10/80 → 12/83	12	AF470 (Fibre) [122] (30-027571-00) BK450 (Fibre) [123]	CF474 [122] DK450 [123]	EF464 [124]
Metro 1.3L (R.H.D.)				01/80 → 12/90				
Metro 1.3L L,HLE,S				10/80 → 04/90				
Metro 1.3L Surf				11/85 → 04/90				
A Series (12 H)	1275	4	70.61	OHV	40-49/ 54-67			
A+ Series (12 H)	1275	4	70.61	OHV	44/60			
A+ Series (12 HL)	1275	4	70.61	OHV	46/63			

								
	JA439	JM302 (31-027568-00)		HR339 (x2)	<input checked="" type="checkbox"/> NA473 39.7x59x9.5mm, NBR <input checked="" type="checkbox"/> NA584 55x70x10mm, MVQ	HJ013 [39] <input checked="" type="checkbox"/> JR264 [11] [124]		 AD890  AF070  AF470, AF460  BD970  BK450  BL380  BN670  JA439  JC435  JE329  JM252  JM302  KT005  HC031  JJ315
				HR625 <input checked="" type="checkbox"/>	<input checked="" type="checkbox"/> NB586 30x40x7mm, MVQ <input checked="" type="checkbox"/> NB772 88.9x104.8x9.52mm, MVQ			
				HR625 <input checked="" type="checkbox"/>	<input checked="" type="checkbox"/> NB586 30x40x7mm, MVQ <input checked="" type="checkbox"/> NB772 88.9x104.8x9.52mm, MVQ			
	JA439	JM302 (31-027568-00) KT005 (x2) [126] 1965 →	HC048 <input checked="" type="checkbox"/>	HR619 <input checked="" type="checkbox"/>	<input checked="" type="checkbox"/> NA473 39.7x59x9.5mm, NBR <input checked="" type="checkbox"/> NA584 55x70x10mm, MVQ	NA301 [2] <input checked="" type="checkbox"/> HJ013 [39] <input checked="" type="checkbox"/> NB083 [42] [120]		
	JA439	JM302 (31-027568-00)	HC063 <input checked="" type="checkbox"/>	HR339 (x2)	<input checked="" type="checkbox"/> NA473 39.7x59x9.5mm, NBR	NA301 [2] <input checked="" type="checkbox"/> NB684 [38] HJ013 [39] <input checked="" type="checkbox"/> JR264 [11] [124]		
	 JE329 (x2)	JM252				NB685 [2] <input checked="" type="checkbox"/>		
	JA439	JM302 (31-027568-00)		HR339 (x2)	<input checked="" type="checkbox"/> NA473 39.7x59x9.5mm, NBR <input checked="" type="checkbox"/> NB291 82.6x98.7x12.7mm, MVQ	JR264 [11] [124]		
	JC435 01/86 → 12/88		JJ315	HR625 <input checked="" type="checkbox"/>	<input checked="" type="checkbox"/> NB775 40x52x7mm, FPM <input checked="" type="checkbox"/> NB773 46x60x7mm, FPM 1985 → <input checked="" type="checkbox"/> NB774 35x45x7mm, FPM (50-319419-00) 1985 → <input checked="" type="checkbox"/> NB586 30x40x7mm, MVQ → 1985 <input checked="" type="checkbox"/> NB772 88.9x104.8x9.52mm, MVQ			
	JA439	JM302 (31-027568-00)	HC031 <input checked="" type="checkbox"/>	HR339 (x2)	<input checked="" type="checkbox"/> NA473 39.7x59x9.5mm, NBR <input checked="" type="checkbox"/> NA584 55x70x10mm, MVQ	NA448 [2] <input checked="" type="checkbox"/> NA301 [2] <input checked="" type="checkbox"/> NB684 [38] HJ013 [39] <input checked="" type="checkbox"/> NB083 [42] [120] JR264 [11] [124]		
		JM302 (31-027568-00)						
	JA439	JM302 (31-027568-00)		HR339 (x2)	<input checked="" type="checkbox"/> NA473 39.7x59x9.5mm, NBR <input checked="" type="checkbox"/> NA584 55x70x10mm, MVQ	HJ013 [39] <input checked="" type="checkbox"/> JR264 [11] [124]		

AUSTIN



KW/PS



Metro 1.3L 10/80 → 04/90 13						AF470 (Fibre) [122] (30-027571-00)	CF474 [122] DK450 [123]	EK451
Metro 1.3L GTa 01/84 → 12/90								
Metro 1.3L Sport 01/84 → 12/90						BK450 (Fibre) [123]		
Metro 1.3L Vanden Plas 01/84 → 12/90								
A Series (12 H)	1275	4	70.61	OHV	40-49/ 54-67			
A+ Series (12 HA)	1275	4	70.61	OHV	51/69			
A+ Series (12 H996)	1275	4	70.61	OHV	52/71			
Metro 1.3L Turbo 10/83 → 04/90 14						AF470 (Fibre) [122] (30-027571-00)	DK451 [123]	EF464 [124]
12 HA85AA 1275 4 70.61 Carburettor, OHV 66/89						BK450 (Fibre) [123]		
Metro Vanden Plas 1.3L 01/82 → 12/88 15						AF470 (Fibre) [122] (30-027571-00)	CF474 [122] DK450 [123]	EF464 [124]
A+ Series 1275 4 70.62						BK450 (Fibre) [123]		
Metropolitan Taxi Diesel 01/83 → 16						BM850 (Fibre) (30-027588-00)	DM852	EM852
19 J 2495 4 90.47 Indirect Injection, Turbo								
Mini 850 Mk I 01/67 → 08/79 17						AF070 (Fibre) [121] (30-027570-00)	CF070	EF075 [125] EF07C [124]
A Series 848 4 62.92 OHV 25-26/ 34-35								
Mini 850 MkII 01/68 → 12/70 18						AF070 (Fibre) [121] (30-027570-00)	CF070	EF075 [125] EF07C [124]
Mini SDL 01/78 → 12/80								
A Series 848 4 62.92								
Mini 1.0L 01/79 → 12/85 19						AF070 (Fibre) [121] (30-027570-00)	CF070	EF075 [125] → 1979 EF07C [124] 1979 →
Mini 1.0L City 01/79 → 12/85								
Mini 1.0L HL 01/79 → 12/85								
Mini 1000 10/67 → 09/84								
Mini City 01/75 → 12/82								
Mini Clubman 1000 MkII 01/69 → 12/75								
Mini Estate 01/75 → 12/82								
Mini HL 01/75 → 12/82								
A Series 998 4 64.56 26/35								
Mini 1.0L City E 01/85 → 06/92 20						AF070 (Fibre) [121] (30-027570-00)	CF073	EF07C [124]
Mini 1.0L City HLE 01/85 → 06/92								
Mini 1000 Mayfair 08/82 → 06/93								
Mini 1000 Mayfair Sport 09/88 → 06/93								
A+ Series (99H) 998 4 64.56 OHV 30/42								
A+ Series (99H) 998 4 64.56 OHV 31/42								
Mini 1.0L MkII 01/67 → 12/79 21						AF070 (Fibre) [121] (30-027570-00)	CF070	EF075 [125]
Mini Clubman 01/59 → 12/75								
Mini Cooper 01/65 → 12/70								
A Series 998 4 64.56								

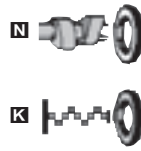
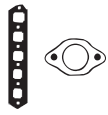

AF070



AF470



BK450



BM850



JA439



JC882



JM302



JM350



KT005



HC031

	JA439	JM302 (31-027568-00)		HR339 (x2)	<input checked="" type="checkbox"/> NA473 39.7x59x9.5mm, NBR <input checked="" type="checkbox"/> NB291 82.6x98.7x12.7mm, MVQ	JR264 [11][124]
		JM302 (31-027568-00)	HC031	HR339 (x2)	<input checked="" type="checkbox"/> NA473 39.7x59x9.5mm, NBR <input checked="" type="checkbox"/> NA584 55x70x10mm, MVQ	NA448 [2] NA301 [2] NB684 [38] HJ013 [39] NB083 [42][120] JR264 [11][124]
	JA439	JM302 (31-027568-00)	HC031	HR339 (x2)	<input checked="" type="checkbox"/> NA473 39.7x59x9.5mm, NBR <input checked="" type="checkbox"/> NA584 55x70x10mm, MVQ	NA448 [2] NA301 [2] NB684 [38] HJ013 [39] NB083 [42][120] JR264 [11][124]
	JC882	JM350			<input checked="" type="checkbox"/> NB775 40x52x7mm, FPM <input checked="" type="checkbox"/> NB849 48.7x63.5x8mm, FPM (50-319467-00) <input checked="" type="checkbox"/> NB848 100x120x11mm, PTFE	
	JA439	JM302 (31-027568-00) KT005 [126] 1965→	HC031	HR619	<input checked="" type="checkbox"/> NA473 39.7x59x9.5mm, NBR <input checked="" type="checkbox"/> NA584 55x70x10mm, MVQ	NA301 [2] NB684 [38] HJ013 [39] NB083 [42][120] JR264 [11][124]
	JA439	JM302 (31-027568-00) KT005 [126] 1965→	HC031	HR619	<input checked="" type="checkbox"/> NA473 39.7x59x9.5mm, NBR <input checked="" type="checkbox"/> NA584 55x70x10mm, MVQ	NA301 [2] NB684 [38] HJ013 [39] NB083 [42][120] JR264 [11][124]
	JA439	JM302 (31-027568-00) KT005 (x2) [126]	HC031	HR619	<input checked="" type="checkbox"/> NA473 39.7x59x9.5mm, NBR <input checked="" type="checkbox"/> NA584 55x70x10mm, MVQ	NA448 [2] NA301 [2] NB684 [38] HJ013 [39] NB083 [42][120] JR264 [11][124]
	JA439	JM302 (31-027568-00) KT005 (x2) [126]	HC031	HR339 (x2)	<input checked="" type="checkbox"/> NA473 39.7x59x9.5mm, NBR <input checked="" type="checkbox"/> NA584 55x70x10mm, MVQ	NA448 [2] NA301 [2] NB684 [38] HJ013 [39] NB083 [42][120] JR264 [11][124]
	JA439	JM302 (31-027568-00) KT005 (x2) [126]	HC031	HR619	<input checked="" type="checkbox"/> NA473 39.7x59x9.5mm, NBR <input checked="" type="checkbox"/> NA584 55x70x10mm, MVQ	NA448 [2] NA301 [2] NB684 [38] HJ013 [39] NB083 [42][120] JR264 [11][124]











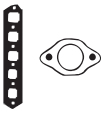

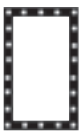

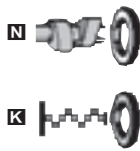



























































































AUSTIN



KW/PS



Mini Cooper S 01/64 → 12/66 22					AF460 (Fibre) [121] (30-027582-00) AF470 (Fibre) [122] (30-027571-00)	CF470 [122]	EF075 [125]
A Series	970	4	70.62	Carburettor			
Mini 1100 Mk I Special 05/76 → 08/81 23					AF070 (Fibre) [121] (30-027570-00)	CF070 [122]	EF075 [125] EF07C [124]
Mini 1100 Special 01/76 → 08/81							
Mini Clubman 1100 05/75 → 12/80							
Mini Clubman 1100 Estate 01/75 → 12/80							
10 HA	1098	4	64.56	Carburettor	33/45		
A series (10H)	1098	4	64.56	Carburettor, OHV	33/45		
Mini Cooper S 01/63 → 12/64 24					AF460 (Fibre) [121] (30-027582-00) AF470 (Fibre) [122] (30-027571-00)	CF470 [122]	EF075 [125]
A Series	1071	4	70.62	Carburettor			
Mini 1275 GT 10/69 → 08/80 25					AF460 (Fibre) [121] (30-027582-00) AF470 (Fibre) [122] (30-027571-00)	CF463 [121] CF473 [122] 01/75 →	EF462 [125] EF464 [124] 01/75 →
A Series	1275	4	70.61		39/53		
Mini Cooper S 01/64 → 12/71 26					AF460 (Fibre) [121] (30-027582-00) AF470 (Fibre) [122] (30-027571-00)	CF470 [122]	EF075 [125] → 10/67 EF462 [125] 11/67 →
A Series	1275	4	70.62	Carburettor			
Montego 1.3L 10/84 → 08/88 27					AF470 (Fibre) [122] (30-027571-00) BK450 (Fibre) [123]	CF474 [122] DK450 [123]	EK451
A+ Series (12 HL)	1275	4	70.61	OHV	46/63		
Montego 1.6L 10/84 → 08/88 28					BL380 (Fibre)	DL381 01/86 → 12/88	
Montego 1.6L LS, HL 04/84 → 08/88							
16 H (S Series)	1598	4	76.20	Injection, SOHC	61/82		
Montego 2.0L 04/84 → 08/91 29					BN670 (Fibre) → 1990	DN671 1985 → → 1988 DN676 1988 → Injection	EM684 1985 →
Montego HLI 10/84 → 08/88							
Montego Mayfair 04/84 → 08/88							
O Series (20HSC)	1994	4	84.44	Carburettor, SOHC	74/100		
O Series (20H)	1994	4	84.44	Injection, SOHC	74-83/ 101- 113		
20 H (O Series)	1994	4	84.44	SOHC	83/113		
Princess 1700 10/78 → 10/82 30					BD970 (Fibre)		
O Series	1695	4	84.44		65/88		
Princess 2000 10/78 → 10/82 31					BD970 (Fibre)		
O Series	1994	4	84.44		69/94		

								
	JA439	KT005 (x2) [126]	HC031 	HR339 	 NA473  39.7x59x9.5mm, NBR  NA584  55x70x10mm, MVQ	NA301  [2]  NB684  [38] HJ013  [39] 	 AF070  AF460, AF470  BD970  BK450  BL380  BN670  JA439  JC240  JC435  JM302  JN549  KT005  HC031  JJ315	
	JA439	JM302 (31-027568-00) KT005 (x2) [126]	HC031 	HR619 	 NA473  39.7x59x9.5mm, NBR  NA584  55x70x10mm, MVQ	NB684  [38] HJ013  [39]  NB083  [42] [120] JR264  [11] [124]		
	JA439	KT005 (x2) [126]	HC031 	HR339 	 NA473  39.7x59x9.5mm, NBR  NA584  55x70x10mm, MVQ	NA301  [2]  HJ013  [39] 		
	JA439	JM302 (31-027568-00)	HC031 	HR339 	 NA473  39.7x59x9.5mm, NBR	NA448  [2]  NA301  [2]  HJ013  [39]  JR264  [11] [124]		
	JA439	KT005 (x2) [126] →10/67	HC031 	HR339 	 NA473  39.7x59x9.5mm, NBR  NA584  55x70x10mm, MVQ	NA301  [2]  NB684  [38] →07/68 HJ013  [39] 		
	JA439	JM302 (31-027568-00)		HR339 	 NA473  39.7x59x9.5mm, NBR  NB291  82.6x98.7x12.7mm, MVQ	JR264  [11] [124]		
	JC240	JN549  →1986		HR622 	 NB775 (x2) 40x52x7mm, FPM  NB586  30x40x7mm, MVQ  NB772  88.9x104.8x9.52mm, MVQ			
	JC435		JJ315	HR625 	 NB775  (x2) 40x52x7mm, FPM 1985→  NB773  46x60x7mm, FPM 1985→  NB774  35x45x7mm, FPM (50-319419-00)  NB772  88.9x104.8x9.52mm, MVQ			
				HR625 	 NB586  30x40x7mm, MVQ  NB772  88.9x104.8x9.52mm, MVQ			
				HR625 	 NB586  30x40x7mm, MVQ  NB772  88.9x104.8x9.52mm, MVQ			











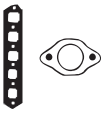

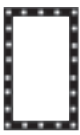

































































































BEDFORD



KW/PS



Astra 1.3L L				01/82 → 12/88		1	BK470 (Fibre) (30-024033-10)	DK470 (21-24033-26/0) → 12/85 → Eng.1535880 → Eng.19417531 DK471 (21-24033-30/0) 01/86 → Eng.1535881 → Eng.19417532 →	EK470 (22-27194-05/0)
13 S	1297	4	75.00		42-55/ 57-75				
1.3 N	1297	4	75.00	Carburettor, SOHC					
Astra 1.6L D Diesel				07/82 → 01/89		2	BLO10 (Fibre), 1.40mm (30-025124-10) → 0.75mm BLO20 (Fibre), 1.50mm, 1 Notch (30-025125-10) → 0.75 → 0.85mm BLO30 (Fibre), 1.60mm, 2 Notches (30-025126-10) → 0.85mm →	DL010▲ (25-24572-02/0) → 11/86 DL011▲ (21-26198-20/0) 12/86 →	EK481 (22-25011-00/0) → 11/86 EK485 (22-25011-04/0) 12/86 →
1.6 DA	1598	4	80.00	SOHC					
Astra 1.6L L				01/87 → 12/90		3	BP800 (Fibre) (30-025706-20)	DP800 (21-25706-26/0)	EK484 [129] (22-27194-01/0)
1.6 SV	1598	4	79.00	Carburettor, SOHC	60/81				
Astra 1.7L D Diesel				01/89 → 06/90		4	BY330 (Fibre), 1.30mm (30-027492-10) BY340 (Fibre), 1.40mm, 1 Notch (30-027493-10) BY350 (Fibre), 1.50mm, 2 Notches (30-027494-10)	DL011▲ (21-26198-20/0)	EK485 (22-25011-04/0)
1.7 D/1.7 DR	1700	4	82.50	SOHC					
Astramax 1.3L L				01/85 → 12/88		5	BK470 (Fibre) (30-024033-10)	DK470 (21-24033-26/0) → 12/85 → Eng.1535880 → Eng.19417531 DK471 (21-24033-30/0) 01/86 → Eng.1535881 → Eng.19417532 →	EK470 (22-27194-05/0)
13 S	1297	4	75.00		42-55/ 57-75				
1.3 N	1297	4	75.00	Carburettor, SOHC					
Astramax 1.6L D Diesel				09/85 → 01/89		6	BLO10 (Fibre), 1.40mm (30-025124-10) → 0.75mm BLO20 (Fibre), 1.50mm, 1 Notch (30-025125-10) → 0.75 → 0.85mm BLO30 (Fibre), 1.60mm, 2 Notches (30-025126-10) → 0.85mm →	DL010▲ (25-24572-02/0) → 11/86 DL011▲ (21-26198-20/0) 12/86 →	EK481 (22-25011-00/0) → 11/86 EK485 (22-25011-04/0) 12/86 →
1.6 DA	1598	4	80.00	SOHC					
Astramax 1.6L L				01/87 → 12/90		7	BP800 (Fibre) (30-025706-20)	DP800 (21-25706-26/0)	EK484 [129] (22-27194-01/0)
1.6 SV	1598	4	79.00	Carburettor, SOHC	60/81				

								
HBS002  (22-29098B) M10x1.25x140mm (x10)	JC280  (31-024313-10) JC281  (31-024312-10)  JE119 (31-024520-00)	JN344 [127] (31-024299-00) →12/85 JN626 [128] (31-026099-10) 01/86 →	JH5005 [116] (31-027194-00) JJ120	HR342  (24-30590-05/0)	 NC006  35x48x7mm, MVQ (50-319161-00)  NB697  26x42x8mm, FPM (50-306704-00)  NB698  80x98x10mm, FPM (50-319273-00)	NB575 [2]  NF685 [42]	 BK470  BL010, BL020, BL030  BP800  BY330, BY340, BY350  JC280  JC281  JC436  JC437  JC824  JE119  JE120  JN344  JN453  JN626  JN693  JH5005  JJ120  JJ200	
HBS074  (22-29100B) M11x1.25x154mm (x10)	JC436  (31-028012-00) JC437  (31-024854-10)  JE119 (31-024520-00)	JN453 [127] (31-024572-00) →11/86 JN693 [128] (31-026198-10) 12/86 →	JJ200 (31-025011-00)	HR343  (24-30602-50/0)	 NC006  35x48x7mm, MVQ (50-319161-00)  NB734  35x50x8mm, FPM  NB701  86x104x11mm, FPM (50-306261-50) →11/86  NB806  90x104x11mm, FPM (50-306552-00) 12/86 →	NB575 [2] 		
HBS002  (22-29098B) M10x1.25x140mm (x10)	JC824  (31-026334-00) JC281  (31-024312-10)  JE120 (31-024767-00)	JN626 (31-026099-10)	JH5005 (x2) [116] (31-027194-00) JJ120 (x2)	HR342  (24-30590-05/0)	 NC006  35x48x7mm, MVQ (50-319161-00)  NB697  26x42x8mm, FPM (50-306704-00)  NB698  80x98x10mm, FPM (50-319273-00)			
HBS074  (22-29100B) M11x1.25x154mm (x10)	JC436  (31-028012-00) JC437  (31-024854-10)  JE119 (31-024520-00)	JN693 [128] (31-026198-10)	JJ200 (31-025011-00)	HR343  (24-30602-50/0)	 NC006  35x48x7mm, MVQ (50-319161-00)  NB734  35x50x8mm, FPM  NB806  90x104x11mm, FPM (50-306552-00)	NB575 [2] 		
HBS002  (22-29098B) M10x1.25x140mm (x10)	JC280  (31-024313-10) JC281  (31-024312-10)  JE119 (31-024520-00)	JN344 [127] (31-024299-00) →12/85 JN626 [128] (31-026099-10) 01/86 →	JH5005 [116] (31-027194-00) JJ120	HR342  (24-30590-05/0)	 NC006  35x48x7mm, MVQ (50-319161-00)  NB697  26x42x8mm, FPM (50-306704-00)  NB698  80x98x10mm, FPM (50-319273-00)	NB575 [2]  NF685 [42]		
HBS074  (22-29100B) M11x1.25x154mm (x10)	JC436  (31-028012-00) JC437  (31-024854-10)  JE119 (31-024520-00)	JN453 [127] (31-024572-00) →11/86 JN693 [128] (31-026198-10) 12/86 →	JJ200 (31-025011-00)	HR343  (24-30602-50/0)	 NC006  35x48x7mm, MVQ (50-319161-00)  NB734  35x50x8mm, FPM  NB701  86x104x11mm, FPM (50-306261-50) →11/86  NB806  90x104x11mm, FPM (50-306552-00) 12/86 →	NB575 [2] 		
HBS002  (22-29098B) M10x1.25x140mm (x10)	JC824  (31-026334-00) JC281  (31-024312-10)  JE120 (31-024767-00)	JN626 (31-026099-10)	JH5005 (x2) [116] (31-027194-00) JJ120 (x2)	HR342  (24-30590-05/0)	 NC006  35x48x7mm, MVQ (50-319161-00)  NB697  26x42x8mm, FPM (50-306704-00)  NB698  80x98x10mm, FPM (50-319273-00)			

BEDFORD



KWPS



Astramax 1.7L D Diesel					01/89 → 06/90	8	BY330 (Fibre), 1.30mm (30-027492-10) BY340 (Fibre), 1.40mm, 1 Notch (30-027493-10) BY350 (Fibre), 1.50mm, 2 Notches (30-027494-10)	DL011▲ (21-26198-20/0)	EK485 (22-25011-04/0)
1.7 D/1.7 DR	1700	4	82.50	SOHC					
Blitz 2.0L					02/85 → 10/87	9	BJ170 (Fibre) (30-025662-10)		
20 N	1979	4	95.00	SOHC	56-58/ 76-79				
Blitz 2.3L					02/80 → 10/83	10	AK300 (Fibre)	CK302○	EG851
23 L	2278	4	97.53	SOHC	58-59/ 79-80				
Blitz 2.3L D Diesel					01/73 → 10/87	11	BR010 (Fibre), 1.30mm, 1 Hole (30-025657-10) BR020 (Fibre), 1.40mm, 2 Holes (30-025658-10) BR030 (Fibre), 1.50mm, 3 Holes (30-025659-10)	DR012▲■ (21-24240-23/0) 01/80 →	
23D	2260	4	92.00	SOHC	46-48/ 63-65				
Brava 4X2 Pick-up Diesel					12/88 → 02/90	12	BM370 (Fibre) (30-028348-00)	DM370○ (21-28348-21/0)	GM370○
C223	2238	4	88.00		39/53				
Brava 4X2 Pick-up					12/88 → 01/93	13	BP920 (Graphite) (30-028321-00)	DP920 (21-28321-20/0)	GP920 [130] GP921 [131]
Brava 4X4 Pick-up					12/88 → 01/93				
4 ZD1	2254	4	89.30		69-72/ 94-98				
CF 2.3L D Diesel					01/78 → 12/88	14	BR010 (Fibre), 1.30mm, 1 Hole (30-025657-10) BR020 (Fibre), 1.40mm, 2 Holes (30-025658-10) BR030 (Fibre), 1.50mm, 3 Holes (30-025659-10)	DR012▲■ (21-24240-23/0) 01/80 →	EJ161
23D	2260	4	92.00	SOHC	46-48/ 63-65				
CF 2.3L L					01/72 → 12/84	15	AK300 (Fibre)	CK302○	EG851
23 L	2278	4	97.53	SOHC	58-59/ 79-80				
CF2 2.0L L					05/84 → 12/87	16	BJ170 (Fibre) (30-025662-10)		
20 N	1979	4	95.00	SOHC	56-58/ 76-79				
Chevanne 1.3L L					01/71 → 12/83	17			
Chevanne 1.3L					06/76 → 12/82				
	1256	4			39/53 40/54				
	1256	4							
Midi 1.8L					09/84 → 05/88	18	BM330 (Graphite) (30-028358-00)	DM330■	
4ZB1	1818	4	82.00		63/86				
Midi 2.0L D Diesel					01/85 →	19	BN190 (Graphite)	DN190○	GN190○
4FC1	1995	4	84.00						
Midi 2.0L L					03/88 →	20	BP980 (Graphite)	DP980	GP980
4ZC1	1995	4	88.00	SOHC					
Midi 2.2L D Diesel					03/88 → 06/90	21	BR190 (Graphite) (30-028342-00)	DR190 (21-28342-20/0)	GR190
4FD1	2189	4	88.00	Indirect Injection, SOHC	54-45/ 73-61				
Midi 2.2L D Diesel					06/88 → 08/92	22	BR190 (Graphite) (30-028342-00)	DR190 (21-28342-20/0)	
Midi 2.2L D 4WD Diesel					06/88 → 08/92				
22DIE	2189	4	88.00	Indirect Injection, SOHC	45/61				

HBS074 (22-29100B) M11x1.25x154mm (x10)	JC436 (31-028012-00) JC437 (31-024854-10) JE119 (31-024520-00)	JN693 [128] (31-026198-10)	JJ200 (31-025011-00)	HR343 (24-30602-50/0)	NC006 35x48x7mm, MVQ (50-319161-00) NB734 35x50x8mm, FPM NB806 90x104x11mm, FPM (50-306552-00)	NB575 [2]
HBS161 (22-29007B) M12x1.50x64mm (x5) M12x1.50x97.5mm (x5)	JC155 (31-021058-20)	JN041 (31-022926-10)		HR336 (24-30656-05/0)		
	JA608 JA609	JM550			NA567 44.5x63.5x9.52mm, ACM	
		JN523 JN521 (31-023007-10)		HR336 (24-30656-05/0) →12/79		
	JC643 JE019	JN408	JH016		NJ267 42x55x9mm, NBR NJ266 65x84x9mm, NBR NJ265 82x105x13mm, MVQ	
	JC684 JC683	JN634 (50-028320-00) HL532	JJ358 [131]	PA933 (x8)	NJ454 30x45x8mm, NBR NJ323 40x56x7mm, NBR NJ322 95x118x10mm, NBR	
		JN521 (31-023007-10) JN523	HC417 (23-21237-01/0)	HR336 (24-30656-05/0) →12/79 →Eng.165317	NB628 45x60x9mm, ACM (50-305272-00) NB690 81x100.1x11.5mm, FPM (50-319087-00)	
	JA608 JA609	JM550			NA567 44.5x63.5x9.52mm, ACM	
		JN041 (31-022926-10)	HC417 (23-21237-01/0)	HR336 (24-30656-05/0)	NB628 45x60x9mm, ACM (50-305272-00) NB469 77x100x11.5mm, FPM (50-306260-50)	
		JM413	HC059	HR291 (50-024209-00)		NB575 [2]
	JC670 JC683	JN634 (50-028320-00) HL532	JJ358	PA933 (x8)	NJ454 30x45x8mm, NBR NJ323 40x56x7mm, NBR NJ322 95x118x10mm, NBR	
	JC429 JC284	JN456	JJ204		NJ321 28x47x8mm, NBR NJ323 40x56x7mm, NBR NJ322 95x118x10mm, NBR	
	JC670 JC683	JN634 (50-028320-00) HL532	JJ358	PA933 (x8)	NJ454 30x45x8mm, NBR NJ323 40x56x7mm, NBR NJ322 95x118x10mm, NBR	
	JC429 JC284	JN456	JJ204	PA933 (x8)	NJ321 28x47x8mm, NBR NJ323 40x56x7mm, NBR NJ322 95x118x10mm, NBR	
	JC429 JC284	JN456		PA933 (x8)		

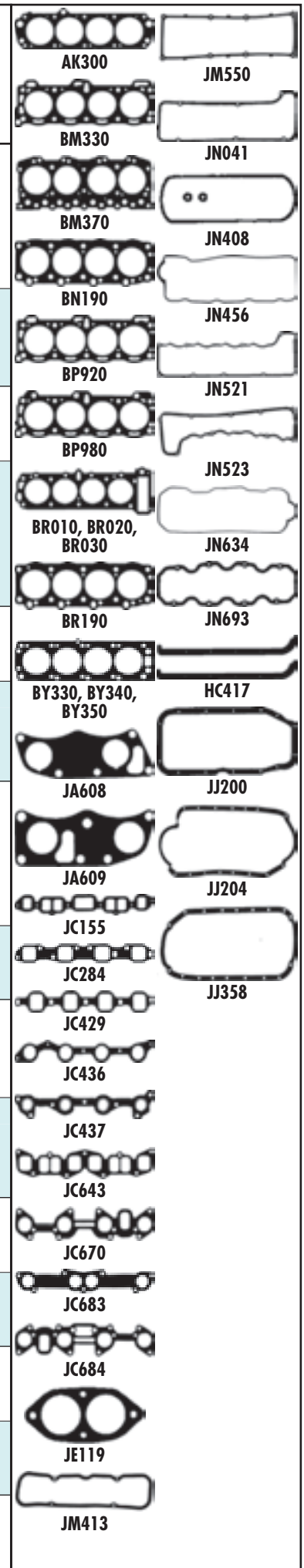





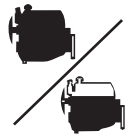

BEDFORD



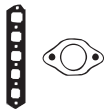

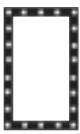

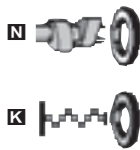

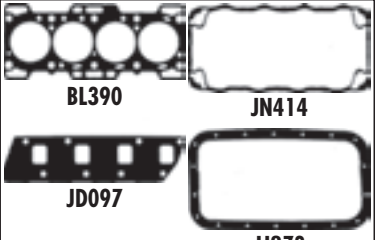









KW/PS



Rascal 1.0L				07/86 → 06/90	23	BL390 (Graphite)	DL391	GL391
FA10A	970	4	65.50	SOHC	34/46	(30-028127-00)	(21-28127-21/0)	(20-28127-01/0)

							
	<p>JC420 (x2) JD097 JE735</p>	<p>JN414</p>	<p>JJ273</p>	<p>PA305 (x8)</p>	<p>NJ336 32x47x8mm, NBR NJ336 32x47x8mm, NBR NJ337 60x80x8mm, NBR</p>		

		CC			9			CC			9
M 10 B 16	Petrol	1573	4	84.00	8	M 47 204 D1	Diesel	1951	4	84.00	85
M 10 B 18	Petrol	1766	4	89.00	15	M 47 D 20	Diesel	1951	4	84.00	35
M 10 B 18	Petrol	1766	4	89.00	16	M 47 D 20	Diesel	1951	4	84.00	85
M 10 B 18	Petrol	1766	4	89.00	22	M 47 N 204 D4	Diesel	1995	4	84.00	154
M 10 B 18	Petrol	1766	4	89.00	72	M 47 N 204 D4	Diesel	1995	4	84.00	36
M 10 B 18	Petrol	1766	4	89.00	73	M 47 N 204 D4	Diesel	1995	4	84.00	4
M 10 B 18	Petrol	1767	4	89.00	17	M 47 N 204 D5	Diesel	1995	4	84.00	36
M 10 B 18	Petrol	1767	4	89.00	22	M 47 N 204 D5	Diesel	1995	4	84.00	86
M 20 B 20	Petrol	1991	6	80.00	37	M 50 B	Petrol	1991	6	80.00	39
M 20 B 20	Petrol	1991	6	80.00	77	M 50 B	Petrol	1991	6	80.00	79
M 20 B 20	Petrol	1991	6	80.00	78	M 50 B 20	Petrol	1991	6	80.00	38
M 20 B 23	Petrol	2316	6	80.00	44	M 50 B 20	Petrol	1991	6	80.00	39
M 20 B 25	Petrol	2494	6	84.00	169	M 50 B 20	Petrol	1991	6	80.00	79
M 20 B 25	Petrol	2494	6	84.00	51	M 50 B 20 TU	Petrol	1991	6	80.00	38
M 20 B 25	Petrol	2494	6	84.00	90	M 50 B 20 TU	Petrol	1991	6	80.00	39
M 20 B 27	Petrol	2693	6	84.00	56	M 50 B 20 TU	Petrol	1991	6	80.00	79
M 20 B 27	Petrol	2693	6	84.00	96	M 50 B 25	Petrol	2494	6	84.00	52
M 21 D 24	Diesel	2443	6	80.00	50	M 50 B 25	Petrol	2494	6	84.00	54
M 21 D 24	Diesel	2443	6	80.00	88	M 50 B 25	Petrol	2494	6	84.00	55
M 21 D 24 W	Diesel	2443	6	80.00	50	M 50 B 25	Petrol	2494	6	84.00	91
M 21 D 24 W	Diesel	2443	6	80.00	88	M 50 B 25	Petrol	2494	6	84.00	92
M 21 D 24 WA	Diesel	2443	6	80.00	50	M 50 B 25 TU	Petrol	2494	6	84.00	52
M 21 D 24 WA	Diesel	2443	6	80.00	88	M 50 B 25 TU	Petrol	2494	6	84.00	54
M 30 B 25	Petrol	2494	6	86.00	89	M 50 B 25 TU	Petrol	2494	6	84.00	55
M 30 B 28	Petrol	2788	6	86.00	106	M 50 B 25 TU	Petrol	2494	6	84.00	91
M 30 B 28	Petrol	2788	6	86.00	121	M 50 B 25 TU	Petrol	2494	6	84.00	92
M 30 B 28	Petrol	2788	6	86.00	128	M 51 D 25	Diesel	2497	6	80.00	100
M 30 B 30	Petrol	2988	6	89.00	108	M 51 D 25	Diesel	2497	6	80.00	101
M 30 B 30	Petrol	2988	6	89.00	131	M 51 D 25	Diesel	2497	6	80.00	102
M 30 B 32	Petrol	3153	6	89.25	137	M 51 D 25	Diesel	2497	6	80.00	58
M 30 B 35	Petrol	3430	6	92.00	115	M 51 D 25	Diesel	2498	6	80.00	102
M 30 B 35	Petrol	3430	6	92.00	123	M 51 D 25	Diesel	2498	6	80.00	103
M 30 B 35	Petrol	3430	6	92.00	125	M 51 D 25	Diesel	2498	6	80.00	104
M 30 B 35	Petrol	3430	6	92.00	138	M 51 D 25	Diesel	2498	6	80.00	127
M 30 B 35	Petrol	3430	6	92.00	139	M 51 D 25	Diesel	2498	6	80.00	59
M 30 B 35	Petrol	3430	6	92.00	140	M 51 D 25	Diesel	2498	6	80.00	60
M 30 B 35	Petrol	3453	6	92.00	114	M 52 B	Petrol	1991	6	80.00	173
M 30 B 35	Petrol	3453	6	92.00	115	M 52 B	Petrol	1991	6	80.00	40
M 30 B 35	Petrol	3453	6	93.40	123	M 52 B	Petrol	1991	6	80.00	81
M 30 B 35	Petrol	3453	6	92.00	124	M 52 B	Petrol	1991	6	80.00	82
M 30 B 35	Petrol	3453	6	92.00	125	M 52 B (20 6 S3) Vanos	Petrol	1991	6	80.00	38
M 30 B 35	Petrol	3453	6	93.40	139	M 52 B (20 6 S3) Vanos	Petrol	1991	6	80.00	39
M 30 B 35	Petrol	3453	6	92.00	140	M 52 B (20 6 S3) Vanos	Petrol	1991	6	80.00	40
M 40 B 16	Petrol	1596	4	84.00	11	M 52 B (20 6 S3) Vanos	Petrol	1991	6	80.00	41
M 40 B 16	Petrol	1596	4	84.00	12	M 52 B (20 6 S3) Vanos	Petrol	1991	6	80.00	80
M 40 B 18	Petrol	1796	4	84.00	21	M 52 B (20 6 S3) Vanos	Petrol	1991	6	80.00	81
M 40 B 18	Petrol	1796	4	84.00	23	M 52 B (20 6 S3) Vanos	Petrol	1991	6	80.00	82
M 40 B 18	Petrol	1796	4	84.00	75	M 52 B 20	Petrol	1991	6	80.00	173
M 41 D 18	Diesel	1665	4	80.00	34	M 52 B 20	Petrol	1991	6	80.00	38
M 42 B 18	Petrol	1796	4	84.00	25	M 52 B 20	Petrol	1991	6	80.00	39
M 42 B 18	Petrol	1796	4	84.00	26	M 52 B 20	Petrol	1991	6	80.00	40
M 42 B 18	Petrol	1796	4	84.00	28	M 52 B 20	Petrol	1991	6	80.00	41
M 43 164 E3	Petrol	1895	4	85.00	19	M 52 B 20	Petrol	1991	6	80.00	81
M 43 194 E1	Petrol	1895	4	85.00	171	M 52 B 20	Petrol	1991	6	80.00	82
M 43 B 16	Petrol	1596	4	84.00	13	M 52 B 25 (Vanos)	Petrol	2494	6	84.00	47
M 43 B 16	Petrol	1596	4	84.00	14	M 52 B 25 (Vanos)	Petrol	2494	6	84.00	48
M 43 B 18	Petrol	1796	4	84.00	170	M 52 B 25 (Vanos)	Petrol	2494	6	84.00	49
M 43 B 18	Petrol	1796	4	84.00	24	M 52 B 25 (Vanos)	Petrol	2494	6	84.00	87
M 43 B 18	Petrol	1796	4	84.00	27	M 52 B 25 (Vanos)	Petrol	2494	6	84.00	92
M 43 B 18	Petrol	1796	4	84.00	74	M 52 B 25 (Vanos)	Petrol	2494	6	84.00	95
M 43 B 18	Bi-Fuel	1796	4	84.00	74	M 52 B 25 TU	Petrol	2494	6	84.00	49
M 43 B 19	Petrol	1895	4	85.00	171	M 52 B 25 TU	Petrol	2494	6	84.00	87
M 43 B 19	Petrol	1895	4	85.00	29	M 52 B 28	Petrol	2793	6	84.00	107
M 43 B 19 TU	Petrol	1895	4	85.00	171	M 52 B 28	Petrol	2793	6	84.00	129
M 43 B 19 TU	Petrol	1895	4	85.00	19	M 52 B 28	Petrol	2793	6	84.00	175
M 43 B 19 TU	Petrol	1895	4	85.00	29	M 52 B 28	Petrol	2793	6	84.00	62
M 44 B 19	Petrol	1895	4	85.00	172	M 52 B 28	Petrol	2793	6	84.00	63
M 44 B 19	Petrol	1895	4	85.00	30	M 52 B 28	Petrol	2793	6	84.00	64
M 47 204 D1	Diesel	1951	4	84.00	35	M 52 B 28 TU	Petrol	2793	6	84.00	107

		CC			9			CC			9
M 52 B 28 TU	Petrol	2793	6	84.00	129	M 62 B 44	Petrol	4398	8	92.00	143
M 52 B 28 TU	Petrol	2793	6	84.00	175	M 62 B 44	Petrol	4398	8	92.00	150
M 52 B 28 TU	Petrol	2793	6	84.00	62	M 62 B 44	Petrol	4398	8	92.00	166
M 52 B 28 TU	Petrol	2793	6	84.00	63	M 62 B 44 A	Petrol	4398	8	92.00	126
M 54 226 S1	Petrol	2171	6	80.00	174	M 62 B 44 A	Petrol	4398	8	92.00	146
M 54 226 S1	Petrol	2171	6	80.00	178	M 62 B 44 A	Petrol	4398	8	92.00	166
M 54 226 S1	Petrol	2171	6	80.00	43	M 62 B 44 TU	Petrol	4398	8	92.00	118
M 54 226 S1	Petrol	2171	6	80.00	84	M 62 B 44 TU	Petrol	4398	8	92.00	119
M 54 256 S5	Petrol	2494	6	84.00	156	M 62 B 44 TU	Petrol	4398	8	92.00	143
M 54 256 S5	Petrol	2494	6	84.00	180	M 62 B 44 TU	Petrol	4398	8	92.00	150
M 54 256 S5	Petrol	2494	6	84.00	53	M 62 B 44 TU	Petrol	4398	8	92.00	166
M 54 256 S5	Petrol	2494	6	84.00	93	M 62 B 46	Petrol	4619	8	93.00	167
M 54 256 S5	Petrol	2494	6	84.00	94	M 67 468 S1	Petrol	4619	8	94.30	167
M 54 306 S3	Petrol	2979	6	84.00	109	M 67 D 39	Diesel	3901	8	84.00	144
M 54 306 S3	Petrol	2979	6	84.00	110	M 70 B 50	Petrol	4988	12	84.00	147
M 54 306 S3	Petrol	2979	6	84.00	133	M 70 B 50	Petrol	4988	12	84.00	151
M 54 306 S3	Petrol	2979	6	84.00	158	M 73 B 54	Petrol	5379	12	85.00	148
M 54 306 S3	Petrol	2979	6	84.00	162	M 73 B 54	Petrol	5379	12	85.00	152
M 54 306 S3	Petrol	2979	6	84.00	176	M57 TU2 D30	Diesel	2993	6	84.00	61
M 54 306 S3	Petrol	2979	6	84.00	182	M57N2306D2	Diesel	2993	6	84.00	159
M 54 306 S3	Petrol	2979	6	84.00	67	M62448S2	Petrol	4398	8	92.00	118
M 54 B 22	Petrol	2171	6	80.00	174	M62448S2	Petrol	4398	8	92.00	119
M 54 B 22	Petrol	2171	6	80.00	178	M62448S2	Petrol	4398	8	92.00	143
M 54 B 22	Petrol	2171	6	80.00	43	N 42 B 18	Petrol	1796	4	84.00	18
M 54 B 22	Petrol	2171	6	80.00	83	N 42 B 20	Petrol	1995	4	84.00	33
M 54 B 22	Petrol	2171	6	80.00	84	N 42 B 20 A	Petrol	1995	4	84.00	5
M 54 B 25	Petrol	2494	6	84.00	156	N 42 B 20 B	Petrol	1995	4	84.00	3
M 54 B 25	Petrol	2494	6	84.00	180	N 45 B 16	Petrol	1596	4	84.00	1
M 54 B 25	Petrol	2494	6	84.00	53	N 45 B 16	Petrol	1596	4	84.00	9
M 54 B 25	Petrol	2494	6	84.00	93	N 45 B 16 A	Petrol	1596	4	84.00	1
M 54 B 25	Petrol	2494	6	84.00	94	N 45 B 16 A	Petrol	1596	4	84.00	9
M 54 B 30	Petrol	2979	6	84.00	109	N 45 B 16 TU2	Petrol	1596	4	84.00	1
M 54 B 30	Petrol	2979	6	84.00	110	N 45 B 16 TU2	Petrol	1596	4	84.00	9
M 54 B 30	Petrol	2979	6	84.00	133	N 46 B 18	Petrol	1796	4	84.00	18
M 54 B 30	Petrol	2979	6	84.00	158	N 46 B 20	Petrol	1995	4	84.00	153
M 54 B 30	Petrol	2979	6	84.00	162	N 46 B 20	Petrol	1995	4	84.00	177
M 54 B 30	Petrol	2979	6	84.00	176	N 46 B 20	Petrol	1995	4	84.00	3
M 54 B 30	Petrol	2979	6	84.00	182	N 46 B 20	Petrol	1995	4	84.00	33
M 54 B 30	Petrol	2979	6	84.00	67	N 46 B 20	Petrol	1995	4	84.00	42
M 54 N 306 D2	Diesel	2993	6	84.00	160	N 46 B 20	Petrol	1995	4	84.00	5
M 57 256 D1	Diesel	2497	6	80.00	98	N 46 B 20 A	Petrol	1995	4	84.00	153
M 57 256 D1	Diesel	2497	6	80.00	99	N 46 B 20 A	Petrol	1995	4	84.00	177
M 57 306 D1	Diesel	2926	6	84.00	135	N 46 B 20 A	Petrol	1995	4	84.00	32
M 57 306 D1	Diesel	2926	6	84.00	164	N 46 B 20 A	Petrol	1995	4	84.00	33
M 57 306 D3	Diesel	2993	6	84.00	105	N 46 B 20 A	Petrol	1995	4	84.00	42
M 57 306 D3	Diesel	2993	6	84.00	134	N 46 B 20 B	Petrol	1995	4	84.00	32
M 57 306 D3	Diesel	2993	6	84.00	163	N 46 B 20 B	Petrol	1995	4	84.00	33
M 57 306 D3	Diesel	2993	6	84.00	61	N 46 B 20 C	Petrol	1995	4	84.00	42
M 57 306 D4	Diesel	2993	6	84.00	113	N 46 B 20 CC	Petrol	1995	4	84.00	33
M 57 D 25	Diesel	2497	6	80.00	99	N 46 B 20 TU2	Petrol	1995	4	84.00	31
M 57 D 25 TU	Diesel	2497	6	80.00	98	N 47 D 20 A	Diesel	1995	4	84.00	36
M 57 D 30	Diesel	2926	6	84.00	112	N 47 D 20 A	Diesel	1995	4	84.00	4
M 57 D 30	Diesel	2926	6	84.00	135	N 47 D 20 A	Diesel	1995	4	84.00	86
M 57 D 30	Diesel	2926	6	84.00	68	N 52 B 25	Petrol	2494	6	82.00	46
M 57 N 256 D4	Diesel	2497	6	84.00	98	N 52 B 25	Petrol	2494	6	82.00	71
M 57 N 306 D2	Diesel	2993	6	84.00	69	N 52 B 25	Petrol	2497	6	82.00	46
M 57 N 306 D4	Diesel	2993	6	84.00	165	N 52 B 25	Petrol	2497	6	82.00	71
M 60 B 30	Petrol	2997	8	84.00	111	N 52 B 25 A	Petrol	2497	6	82.00	155
M 60 B 30	Petrol	2997	8	84.00	132	N 52 B 25 A	Petrol	2497	6	82.00	179
M 60 B 40	Petrol	3982	8	89.00	117	N 52 B 25 A	Petrol	2497	6	82.00	46
M 60 B 40	Petrol	3982	8	89.00	142	N 52 B 25 A	Petrol	2497	6	82.00	71
M 60 B 40	Petrol	3982	8	89.00	149	N 52 B 25 C	Petrol	2497	6	82.00	46
M 62 B	Petrol	3498	8	84.00	116	N 52 B 30	Petrol	2996	6	85.00	122
M 62 B	Petrol	3498	8	84.00	141	N 52 B 30	Petrol	2996	6	85.00	130
M 62 B 35	Petrol	3498	8	84.00	116	N 52 B 30	Petrol	2996	6	85.00	161
M 62 B 35	Petrol	3498	8	84.00	141	N 52 B 30	Petrol	2996	6	85.00	181
M 62 B 35 TU	Petrol	3498	8	84.00	116	N 52 B 30	Petrol	2996	6	85.00	6
M 62 B 44	Petrol	4398	8	92.00	118	N 52 B 30	Petrol	2996	6	85.00	65
M 62 B 44	Petrol	4398	8	92.00	119	N 52 B 30	Petrol	2996	6	85.00	97



CC



9



CC



9

N 52 B 30 A	Petrol	2996	6	85.00	122
N 52 B 30 A	Petrol	2996	6	85.00	130
N 52 B 30 A	Petrol	2996	6	85.00	157
N 52 B 30 A	Petrol	2996	6	85.00	161
N 52 B 30 A	Petrol	2996	6	85.00	181
N 52 B 30 A	Petrol	2996	6	85.00	6
N 52 B 30 A	Petrol	2996	6	85.00	65
N 52 B 30 A	Petrol	2996	6	85.00	66
N 52 B 30 A	Petrol	2996	6	85.00	97
N 53 B 30	Petrol	2996	6	85.00	122
N 53 B 30	Petrol	2996	6	85.00	57
N 53 B 30	Petrol	2996	6	85.00	66
N 53 B 30	Petrol	2996	6	85.00	97
N 54 B 30 A	Petrol	2996	6	84.00	168
N 54 B 30 A	Petrol	2996	6	84.00	7
N 54 B 30 A	Petrol	2996	6	84.00	70
N 57 306 D 2	Diesel	2993	6	84.00	113
N 57 306 D 2	Diesel	2993	6	84.00	136
N 62 B 44	Petrol	4398	8	92.00	120
N 62 B 44	Petrol	4398	8	92.00	126
N 62 B 44	Petrol	4398	8	92.00	146
N 62 B 44	Petrol	4398	8	92.00	166
N 67 398 D 1	Diesel	3901	8	84.00	145
N43B16A	Petrol	1597	4		10
N43B20A	Petrol	1995	4	84.00	2
N43B20A	Petrol	1995	4	84.00	31
N43B20A	Petrol	1995	4	84.00	32
N43B20A	Petrol	1995	4	84.00	76
N46B18A	Petrol	1796	4	84.00	18
N46NB20B	Petrol	1995	4	84.00	33
N52NB25A	Petrol	2497	6		46
N52NB30A	Petrol	2996	6	85.00	57
N52NB30A	Petrol	2996	6	85.00	65
N52NB30B	Petrol	2996	6		57
N53B30A	Petrol	2996	6	85.00	57
N53B30A	Petrol	2996	6	85.00	6
N53B30A	Petrol	2996	6	85.00	66
N53B30A	Petrol	2996	6	85.00	97
N54B30B	Petrol	2979	6	84.00	70
N57306D3	Diesel	2993	6	84.00	61
N57N306D2	Diesel	2993	6	84.00	134
N57N306D3	Diesel	2993	6	84.00	61
S 14 B 23	Petrol	2302	4	93.40	45
S 14 B 23	Petrol	2303	4	93.40	45



KW/PS



1 116 i (E81, E87)					09/04 →	1	AC5440 (MLS), 0.4mm	CC5441
N 45 B 16	1596	4	84.00	DOHC	85/115	30-029315-00	(21-29315-21/0)	
N 45 B 16 A	1596	4	84.00	Injection	85/115	AC5470 (MLS), 0.7mm		
N 45 B 16 TU2	1596	4	84.00	Injection, DOHC	85-90/ 115- 122	30-030333-00		
1 118 i (E81, E87)					04/07 →	2		
1 Cabriolet 118 i (E88)					03/08 →			
1 120 i (E81, E87)					04/07 →			
1 Cabriolet 120 i (E88)					03/08 →			
1 2.0L (E81, E87)					03/07 →			
N43B20A	1995	4	84.00	Injection, DOHC	96-125/ 131- 170			
1 118 i (E81, E87)					09/04 →	3	AC5440 (MLS), 0.4mm	CC5440
N 42 B 20 B	1995	4	84.00	Injection, DOHC	95/129	30-029315-00	21-29315-20/0	
N 46 B 20	1995	4	84.00	DOHC	95-110/ 129- 150	AC5470 (MLS), 0.7mm 30-030333-00		
1 118d (E81, E87) Diesel					09/04 →	4	AC5410 (MLS), 1.45mm, 1 Hole	CC5410
1 120d (E81, E87) Diesel					09/04 →		30-029236-00	21-29236-20/0
M 47 N 204 D4	1995	4	84.00	DOHC	85-120/ 116- 163	AC5420 (MLS), 1.55mm, 2 Holes 30-029237-00	EC5410	
N 47 D 20 A	1995	4	84.00	Direct Injection, DOHC	120-85/ 163- 116	AC5430 (MLS), 1.65mm, 3 Holes 30-029238-00	22-29236-00/0	
1 120i (E81, E87)					09/04 →	5	AC5440 (MLS), 0.4mm	CC5440
N 46 B 20	1995	4	84.00	DOHC	95-110/ 129- 150	30-029315-00 AC5470 (MLS), 0.7mm 30-030333-00	21-29315-20/0	
N 42 B 20 A	1995	4	84.00	Injection, DOHC	110/150			
1 Cabriolet 125 i (E88)					03/08 →	6	AG9290 (MLS), 1,2mm	CG9540
1 Coupe 125 i (E82)					10/07 →		30-030284-00	21-30334-00/0
1 130 i (E81, E87)					03/05 →07/05			EG9540
N53B30A	2996	6	85.00	Injection, DOHC	160- 200/ 218- 272			
N 52 B 30 A	2996	6	85.00	DOHC	190- 195/ 258- 265			
N 52 B 30	2996	6	85.00	DOHC	190- 200/ 258- 272			
1 3.0L (E81, E87)					09/07 →	7	AH5120 (MLS)	
1 Cabriolet 135 i (E88)					03/08 →			
1 Coupe 135 i (E82)					10/07 →			
N 54 B 30 A	2996	6	84.00	Injection, DOHC	225/306			









							 AC5410, AC5420, AC5430
HBS467 (22-11040B) M8x1.25x95mm (x3) M8x1.25x125mm (x3) M10x1.50x170mm (x6)	HA5024 24-29984-00/0 JD5428 (31-029625-00) JE5050 (31-029702-00) 1.30mm	HM5150 24-29590-00/0				NA5263 [42]	 AC5440 JD5183 JD5428 JE5050 JM5167 JH5070
HBS467 (22-11040B) M8x1.25x95mm (x3) M8x1.25x125mm (x3) M10x1.50x170mm (x6)	HA5024 24-29984-00/0 JD5428 (31-029625-00) JE5050 (31-029702-00) 1.30mm	HM5160 24-29591-00/0				NA5263 [42]	
HBS121 (22-11006B) M12x1.50x146.5mm (x10)	JD5183 (x2) (31-029124-00)	JM5167 50-029672-00	JH5070 (31-029678-00)	HR5045 24-30724-07/0	NA5105 48x65x10mm, PTFE (50-319388-00) NA5104 90x110x12mm, PTFE (50-319389-00)	JR5022 [45]	
HBS467 (22-11040B) M8x1.25x95mm (x3) M8x1.25x125mm (x3) M10x1.50x170mm (x6)	HA5024 24-29984-00/0 JD5428 (31-029625-00) JE5050 (31-029702-00) 1.30mm	HM5160 24-29591-00/0					
HBS468 (22-11041B) M9x1.25x95mm (x1) M9x1.25x125mm (x3) M10x1.50x125mm (x10)	JD5864 50-030336-00 JD5909 31-030374-00						
	JD5864 50-030336-00		JH5103 (31-030196-00)				

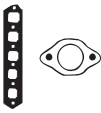

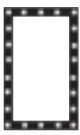
KW/PS

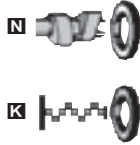

3 315 (E21)						03/81 → 03/84	8	BC910 (Fibre)		
3 315 (E30)						09/82 → 10/83		30-023684-20		
M 10 B 16	1573	4	84.00	Carburettor, CIH	55/75					
3 316 i (E90)						02/06 →	9	AC5440 (MLS), 0.4mm	CC5441	
3 316 i (E46)						06/02 → 02/05		30-029315-00	(21-29315-21/0)	
3 Coupe 316 Ci (E46)						06/02 →		AC5470 (MLS), 0.7mm		
N 45 B 16	1596	4	84.00	DOHC	85/115		30-030333-00			
N 45 B 16 A	1596	4	84.00	Injection	85/115					
N 45 B 16 TU2	1596	4	84.00	Injection, DOHC	85-90/ 115- 122					
3 316 i (E90)						09/07 →	10			
3 Touring 316 i (E91)						09/07 →				
N43B16A	1597	4		Injection	89-90/ 121- 122					
	1599	4			90/122					
3 316 i (E30)						09/87 → 06/94	11	BR830 (Fibre)	DR830	ER830
M 40 B 16	1596	4	84.00	Injection	73/99		30-026068-20	21-26068-21/0	22-26160-00/0	
3 316 i (E30)						09/91 → 06/94	12	BR830 (Fibre)	DR830	ER830
3 316 i (E36)						09/90 → 09/93		30-026068-20	21-26068-21/0	22-26160-00/0
M 40 B 16	1596	4	84.00	Injection	73/99				GC790	20-24065-01/0
3 316 i (E36)						07/93 → 08/00	13	BR830 (Fibre)	DR831■	
3 Coupe 316 i (E36)						09/93 → 04/99		30-026068-20		
M 43 B 16	1596	4	84.00	SOHC	75/102					
3 316 i (E46)						04/00 → 02/05	14	BR830 (Fibre)		EB5660
3 Coupe 316 Ci (E46)						04/00 →		30-026068-20		22-29063-00/0
M 43 B 16	1596	4	84.00	SOHC	75/102					
M 43 B 16	1596	4	84.00	Injection, SOHC	77/105					
3 316 (E30)						09/82 → 12/87	15	BC920 (Fibre)	DC921	
M 10 B 18	1766	4	89.00	Carburettor, CIH	66/90		30-023685-20	21-23685-52/0	DC929■	
							BP610 (Fibre) [249]		(21-23685-48/0)	
							30-023978-10			











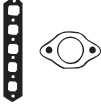

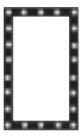

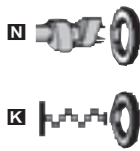

















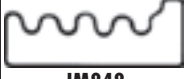







































									
HBS070 ⊗ (22-11035B) M12x1.75x157mm (x10)		JN299 (31-020446-20)	JJ089 (31-020447-30)	HR569 ⊗ 24-30667-00/0	NB432 ⊗ 35x55x12mm, ACM (50-306695-50) NA5104 ⊗ 90x110x12mm, PTFE (50-319389-00) NB431 ⊗ 90x110x12mm, FPM (50-306091-50)	NJ011 [2]⊗ FPM/ACM		AC5440	JJ612
HBS467 (22-11040B) M8x1.25x95mm (x3) M8x1.25x125mm (x3) M10x1.50x170mm (x6)	HA5024 ⊗⊗ 24-29984-00/0 JD5428 ⊗ (31-029625-00)	HM5150 ⊗ 24-29590-00/0					NA5263 [42]	BC910	
	JD5909 ⊗ (x4) 31-030374-00							BC920	
HBS069 ⊗ (22-11004B) M10x1.50x95mm (x10)	JD189 ⊗⊗ (x2) (31-026153-00) JD283 ⊗⊗ (31-026152-10) JD243 ⊗ [274] 31-027845-00 ⊗ JE5019 (31-026163-00)	JN698 50-026154-10	JH5112 (31-026161-00) JJ537 (31-026160-10)	HR646 ⊗ 24-30670-60/0	NB799 ⊗ 38x50x7mm, FPM (50-306223-50) NB980 ⊗ 42x52x7.5mm, FPM (50-306661-50) NB431 ⊗ 90x110x12mm, FPM (50-306091-50)	NA5263 [42]		BP610	
HBS069 ⊗ (22-11004B) M10x1.50x95mm (x10)	JD189 ⊗⊗ (x2) (31-026153-00) JD283 ⊗⊗ (31-026152-10) JD243 ⊗ [274] 31-027845-00 ⊗ JE5019 (31-026163-00)	JM848 50-022825-00	JH5112 (31-026161-00) JJ537 (31-026160-10)	HR646 ⊗ 24-30670-60/0	NB799 ⊗ 38x50x7mm, FPM (50-306223-50) NB980 ⊗ 42x52x7.5mm, FPM (50-306661-50) NB431 ⊗ 90x110x12mm, FPM (50-306091-50)	NA5263 [42]		BR830	
HBS069 ⊗ (22-11004B) M10x1.50x95mm (x10)	JD608 ⊗ (x2) (31-027565-00) →09/95 JD283 ⊗⊗ (31-026152-10) JD611 ⊗ (x2) (31-028409-00) 09/95→ JD243 ⊗ [274] 31-027845-00 ⊗ JE5019 (31-026163-00)	JP079 50-028394-00	JJ537 (31-026160-10) →08/95 JJ612 (50-028405-00) 09/95→	HR646 ⊗ 24-30670-60/0	NC015 ⊗ 44x60x10mm, FPM (50-306445-50) NB431 ⊗ 90x110x12mm, FPM (50-306091-50)	JR5031 [11]		JD071	
HBS069 ⊗ (22-11004B) M10x1.50x95mm (x10)	JD5858 ⊗ 50-029061-00 JD243 ⊗ [274] 31-027845-00	JP079 50-028394-00	JH5050 (50-029063-00)	HR646 ⊗ 24-30670-60/0	NA5099 ⊗ 44x60x10mm, PTFE (50-319382-00) NA5104 ⊗ 90x110x12mm, PTFE (50-319389-00)	JR5031 [11]		JD243	
HBS070 ⊗ (22-11035B) M12x1.75x157mm (x10)	JD071 ⊗ [274] (31-024675-10)	JN299 (31-020446-20)	JJ089 (31-020447-30)	HR569 ⊗ 24-30667-00/0	NB432 ⊗ 35x55x12mm, ACM (50-306695-50) NA5104 ⊗ 90x110x12mm, PTFE (50-319389-00)	NA5263 [42]		JD283	
								JD5428	
								JD608	
								JD611	
								JE5019	
								JM848	
								JN299	
								JN698	
								JP079	
								JJ089	
								JJ537	



KW/PS



3 316 (Ecotronic) (E30)		09/83 → 12/90		16		BC920 (Fibre)	DC929■	
M 10 B 18	1766	4	89.00	Carburettor, CIH	66/90	30-023685-20 BP610 (Fibre) [249] 30-023978-10	(21-23685-48/0)	
3 316 i (E30)		08/87 → 08/88		17		BC920 (Fibre)		
M 10 B 18	1767	4	89.00	L-Jetronic	75/102	30-023685-20 BP610 (Fibre) [249] 30-023978-10		
3 316 i (E46)		02/02 → 02/05		18		AC5440 (MLS), 0.4mm	CC5440	
3 316 ii (E46)		06/01 → 02/05				30-029315-00 AC5470 (MLS), 0.7mm	21-29315-20/0	
N 42 B 18	1796	4	84.00	Injection, DOHC	85/115			
N 46 B 18	1796	4	84.00	DOHC	85/115			
N46B18A	1796	4	84.00	Injection, DOHC	85/115			
3 316 i (E36)		12/98 → 08/00		19		AB5660 (Fibre)	CB5660■	
3 316 i (E46)		09/98 → 02/05				30-028501-00	21-28501-20/0	
M 43 164 E3	1895	4	85.00	Injection, SOHC	77/105			
M 43 B 19 TU	1895	4	85.00	Injection, SOHC	77-87/ 105- 118			
3 316 g (E36)		12/95 → 08/00		20		BR830 (Fibre)	DR831■	
	1596	4			75/102	30-026068-20		
3 318 i (E30)		09/87 → 06/91		21		BR830 (Fibre)	DR830	ER830
M 40 B 18	1796	4	84.00	Injection	83/113	30-026068-20	21-26068-21/0	22-26160-00/0 GC790 20-24065-01/0
3 318 i (E30)		09/82 → 08/88		22		BC920 (Fibre)	DC92B	
M 10 B 18	1766	4	89.00	L-Jetronic, CIH	75-77/ 102- 105	30-023685-20 BP610 (Fibre) [249] 30-023978-10	21-23685-46/0	
M 10 B 18	1767	4	89.00	L-Jetronic	75/102			
M 10 B 18	1767	4	89.00	K-Jetronic	75-77/ 102- 105			
3 318 i (E30)		04/89 → 06/94		23		BR830 (Fibre)	DR830	ER830
3 318 i (E36)		12/90 → 10/93				30-026068-20	21-26068-21/0	22-26160-00/0
3 Convertible 318 i (E30)		09/90 → 10/93						GC790 20-24065-01/0
M 40 B 18	1796	4	84.00	Injection	83/113			

								
HBS070  (22-11035B) M12x1.75x157mm (x10)	JD071  [274] (31-024675-10)	JN299 (31-020446-20)	JJ089 (31-020447-30)	HR569  24-30667-00/0	NB432  35x55x12mm, ACM (50-306695-50) NA5104  90x110x12mm, PTFE (50-319389-00)	NA5263 [42]	 AB5660  AC5440  BC920  BP610  BR830  JD071  JD243  JD283  JD5428  JD611  JE5019  JE5050  JM848  JN299  JN698  JP079  JJ089  JJ537  JJ612	
HBS070  (22-11035B) M12x1.75x157mm (x10)		JN299 (31-020446-20)	JJ089 (31-020447-30)	HR569  24-30667-00/0	NB432  35x55x12mm, ACM (50-306695-50) NA5104  90x110x12mm, PTFE (50-319389-00)	NA5263 [42]		
HBS467 (22-11040B) M8x1.25x95mm (x3) M8x1.25x125mm (x3) M10x1.50x170mm (x6)	HA5024  24-29984-00/0 JD5428  (31-029625-00) JE5050  (31-029702-00) 1.30mm	HM5160  24-29591-00/0				NA5263 [42]		
HBS069  (22-11004B) M10x1.50x95mm (x10)	JD5858  50-029061-00			HR646  24-30670-60/0	NC015  44x60x10mm, FPM (50-306445-50) NB431  90x110x12mm, FPM (50-306091-50)	JR5031 [11] JR5046 [11]		
HBS069  (22-11004B) M10x1.50x95mm (x10)	JD611  (x2) (31-028409-00) JD283  (31-026152-10) JD243  [274] 31-027845-00 JE5019  (31-026163-00)	JP079 50-028394-00	JJ612 (50-028405-00)	HR646  24-30670-60/0	NB980  42x52x7.5mm, FPM (50-306661-50) NB431  90x110x12mm, FPM (50-306091-50)	JR5031 [11] JR5046 [11]		
HBS069  (22-11004B) M10x1.50x95mm (x10)	JD189  (x2) (31-026153-00) JD283  (31-026152-10) JD243  [274] 31-027845-00 JE5019  (31-026163-00)	JM848 50-022825-00	JH5112 (31-026161-00) JJ537 (31-026160-10)	HR646  24-30670-60/0	NB799  38x50x7mm, FPM (50-306223-50) NB980  42x52x7.5mm, FPM (50-306661-50) NB431  90x110x12mm, FPM (50-306091-50)	NA5263 [42]		
HBS070  (22-11035B) M12x1.75x157mm (x10)	JD071  [274] (31-024675-10)	JN299 (31-020446-20)	JJ089 (31-020447-30)	HR569  24-30667-00/0	NB432  35x55x12mm, ACM (50-306695-50) NA5104  90x110x12mm, PTFE (50-319389-00)	NA5263 [42]		
HBS069  (22-11004B) M10x1.50x95mm (x10)	JD189  (x2) (31-026153-00) JD283  (31-026152-10) JD243  [274] 31-027845-00 JE5019  (31-026163-00)	JN698 50-026154-10	JJ537 (31-026160-10)	HR646  24-30670-60/0	NB799  38x50x7mm, FPM (50-306223-50) NB980  42x52x7.5mm, FPM (50-306661-50) NB431  90x110x12mm, FPM (50-306091-50)	NA5263 [42]		







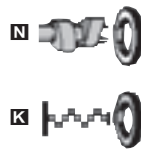
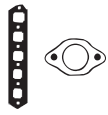

KW/PS



3 318 i (E36)		10/93 → 10/99			24	BR830 (Fibre)	DR831■
M 43 B 18	1796	4	84.00	Injection	85/116	30-026068-20	
3 318 is (E30)		09/89 → 08/91			25	BY560 (Fibre)	DY542■
M 42 B 18	1796	4	84.00	Motronic, DOHC	103/140	30-026346-20	21-26346-23/0
3 318 is (E36)		03/93 → 09/97			26	BY560 (Fibre)	DY520
3 318 ti (E36)		11/94 → 08/95					
M 42 B 18	1796	4	84.00	Motronic, DOHC	103/140	30-026346-20	21-26346-21/0 DY542■ 21-26346-23/0
3 Convertible 318 i (E36)		01/94 → 04/99			27	BR830 (Fibre)	DR831■
M 43 B 18	1796	4	84.00	Injection	85/116	30-026068-20	
3 Coupe 318 is (E36)		03/92 → 10/95			28	BY560 (Fibre)	DY541
M 42 B 18	1796	4	84.00	Motronic, DOHC	103/140	30-026346-20	21-26346-22/0 DY542■ 21-26346-23/0
3 318 i (E46)		02/98 → 09/01			29	AB5660 (Fibre)	CB5660■
3 Coupe 318 Ci (E46)		11/99 → 09/01					
M 43 B 19 TU	1895	4	85.00	Injection, SOHC	77-87/ 105- 118	30-028501-00	21-28501-20/0
M 43 B 19	1895	4	85.00	Injection, SOHC	87/118		
							22-29063-00/0
3 318 is (E36)		09/95 → 02/98			30	BZ130 (Fibre)	DZ130■
3 318 ti (E36)		07/95 → 08/00					
3 Coupe 318 is (E36)		09/95 → 04/99					
M 44 B 19	1895	4	85.00		103/140	30-027702-10	21-27702-21/0







HBS069 
[22-11004B]
M10x1.50x95mm (x10)

JD608  (x2)
[31-027565-00]
→09/95
JD283  
[31-026152-10]
JD611  (x2)
[31-028409-00]
09/95→
JD243  [274]
31-027845-00
 **JE5019**
[31-026163-00]

JP079
50-028394-00
HL733 
[24-26539-00/0]



JJ537
[31-026160-10]
→09/95
JJ612
[50-028405-00]
09/95→



HR646 
24-30670-60/0

 **NA5099**  44x60x10mm, PTFE
[50-319382-00]
 **NB431**  90x110x12mm, FPM
[50-306091-50]

JR5031 [11]
JR5046 [11]





HBS069 
[22-11004B]
M10x1.50x95mm (x10)

JD490  
[31-027564-00]
JD561  (x2)
50-026544-10

JP027 
50-026539-00
JP077  (x3) [134]
50-026540-00



JJ537
[31-026160-10]



HR646 
24-30670-60/0

 **NA5099**  44x60x10mm, PTFE
[50-319382-00]
 **NB431**  90x110x12mm, FPM
[50-306091-50]

KK5684 [53]
JR5041 [45]
JR5042 [45]





HBS069 
[22-11004B]
M10x1.50x95mm (x10)

JD490 
[31-027564-00]
JP027
50-026539-00
JP077 [134]
50-026540-00
JP032  [250]
[50-026541-00]
HL733 
[24-26539-00/0]

JP027
50-026539-00
JP077 [134]
50-026540-00
JP032  [250]
[50-026541-00]
HL733 
[24-26539-00/0]





JJ537
[31-026160-10]

HR817  (x2)
24-30614-78/0

 **NA5099**  44x60x10mm, PTFE
[50-319382-00]
 **NB431**  90x110x12mm, FPM
[50-306091-50]

KK5684 [53]
JR5041 [45]
JR5042 [45]





HBS069 
[22-11004B]
M10x1.50x95mm (x10)

JD283 
[31-026152-10]
JD608  (x2)
[31-027565-00]
→09/95
JD611  (x2)
[31-028409-00]
09/95→
JD243  [274]
31-027845-00
 **JE5019**
[31-026163-00]

JP079
50-028394-00
HL733 
[24-26539-00/0]

JJ537
[31-026160-10]
→09/95
JJ612
[50-028405-00]
09/95→



HR646 
24-30670-60/0

 **NA5099**  44x60x10mm, PTFE
[50-319382-00]
 **NB431**  90x110x12mm, FPM
[50-306091-50]



NA5263 [42]
JR5031 [11]
JR5046 [11]





HBS069 
[22-11004B]
M10x1.50x95mm (x10)

JD490 
[31-027564-00]
JP027
50-026539-00
JP077  (x3) [134]
50-026540-00
HL733 
[24-26539-00/0]

JP027
50-026539-00
JP077  (x3) [134]
50-026540-00
HL733 
[24-26539-00/0]

JJ537
[31-026160-10]

HR646 
24-30670-60/0
→09/93
HR817  (x2)
24-30614-78/0
09/93→

 **NA5099**  44x60x10mm, PTFE
[50-319382-00]
 **NB431**  90x110x12mm, FPM
[50-306091-50]

KK5684 [53]
NA5263 [42]
JR5041 [45]
JR5042 [45]





HBS069 
[22-11004B]
M10x1.50x95mm (x10)

JD5858 
50-029061-00
JD243  [274]
31-027845-00
 **JE5019**
[31-026163-00]

JP079
50-028394-00

JH5050
[50-029063-00]



HR646 
24-30670-60/0

 **NA5099**  44x60x10mm, PTFE
[50-319382-00]
 **NA5104**  90x110x12mm, PTFE
[50-319389-00]





JR5031 [11]
JR5046 [11]

HBS069 
[22-11004B]
M10x1.50x95mm (x10)

JD611  (x2)
[31-028409-00]

JP027
50-026539-00
JP077  (x3)
50-026540-00
HL733 
[24-26539-00/0]

HR817  (x2)
24-30614-78/0

 **NA5099**  44x60x10mm, PTFE
[50-319382-00]
 **NB431**  90x110x12mm, FPM
[50-306091-50]

NA5263 [42]



AB5660



BR830



BY560



BZ130



JD243



JD283



JD490



JD561



JD608



JD611



JE5019



JP027



NA5263



JP077



JR5041



JR5042

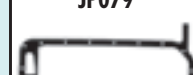

JP079



JJ537













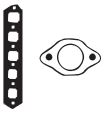

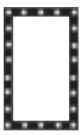

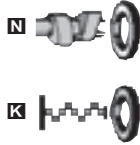

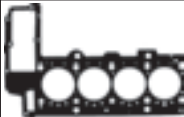

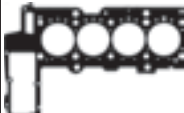

























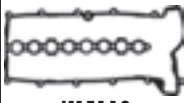

JJ612



KW/PS



3 318 i (E90) 09/07 → 31								
3 Touring 318 i (E91) 09/07 →								
3 320 i (E90) 09/07 →								
3 Coupe 320 i (E92) 03/07 →								
3 Touring 320 i (E91) 09/07 →								
N43B20A	1995	4	84.00	Injection, DOHC	96-125/ 131- 170			
N 46 B 20 TU2	1995	4	84.00	DOHC	100- 115/ 136- 156			
3 Cabriolet 318 Ci (E46) 02/05 → 32						AC5440 (MLS), 0.4mm 30-029315-00 AC5470 (MLS), 0.7mm 30-030333-00	CC5440 21-29315-20/0	
3 Coupe 318 Ci (E46) 03/05 →								
3 Cabriolet 320 i (E93) 03/07 →								
N 46 B 20 B	1995	4	84.00	Injection	95/129			
N 46 B 20 A	1995	4	84.00	Injection, DOHC	110/150			
3 318 i (E46) 09/01 → 02/05 33						AC5440 (MLS), 0.4mm 30-029315-00 AC5470 (MLS), 0.7mm 30-030333-00	CC5440 21-29315-20/0	
3 318 i (E90) 09/05 →								
3 318 i (E91) 01/06 →								
3 318 ti (E46) 09/01 → 02/05								
3 Convertible 318 Ci (E46) 09/01 →								
3 Coupe 318 Ci (E46) 09/01 →								
3 Cabriolet 320 i (E93) 03/07 → 08/07								
3 Coupe 320 i (E92) 11/06 → 06/07								
3 2.0L (E90) 06/05 →								
N 46 B 20 B	1995	4	84.00	Injection	115/156 95/129			
N 46 B 20	1995	4	84.00	DOHC	95-110/ 129- 150			
N 42 B 20	1995	4	84.00	Injection, DOHC	105/143			
N 46 B 20	1995	4	84.00	DOHC	107/146			
N 46 B 20 A	1995	4	84.00	Injection, DOHC	110/150			
N46NB20B	1995	4	84.00	Injection	110/150			
N 46 B 20 CC	1995	4	84.00	DOHC	115/156			
3 318 tds (E36) Diesel 01/95 → 08/00 34						AY270 (Fibre), 1.68mm, 2 Holes 30-027547-20 AY280 (Fibre), 1.87mm, 3 Holes 30-027548-20	CY270 ▲■ 21-27793-20/0	EY270 22-27798-00/0
M 41 D 18	1665	4	80.00	SOHC	66/89			
3 318 d (E46) Diesel 09/01 → 02/05 35						BZ500 (MLS), 1.45mm, 1 Hole 30-028458-00 BZ510 (MLS), 1.55mm, 2 Holes 30-028459-00 BZ520 (MLS), 1.65mm, 3 Holes 30-028460-00 AC5300 (MLS), 1.80mm 30-029182-00	DZ661 ▲■ 21-29148-20/0	EZ800 22-29155-00/0
3 320 d (E46) Diesel 04/98 → 09/01								
M 47 204 D1	1951	4	84.00	DOHC	85-100/ 116- 136			
M 47 D 20	1951	4	84.00	DOHC	100/136			











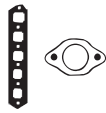

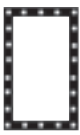



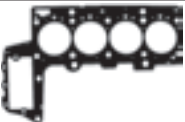















































								
		JD5909  (x4) 31-030374-00						 AC5300  AC5440  AY270, AY280  BZ500, BZ510, BZ520
HBS467 (22-11040B) M8x1.25x95mm (x3) M8x1.25x125mm (x3) M10x1.50x170mm (x6)	HA5024   24-29984-00/0 JD5428  (31-029625-00)  JE5050 (31-029702-00) 1.30mm	HM5160  24-29591-00/0						 JD275  JD5107  JD5108
HBS467 (22-11040B) M8x1.25x95mm (x3) M8x1.25x125mm (x3) M10x1.50x170mm (x6)	HA5024   24-29984-00/0 JD5428  (31-029625-00)  JE5050 (31-029702-00) 1.30mm	HM5160  24-29591-00/0					NA5263 [42]	 JD5183  JD5428  JD612  JE5050
HBS121  (22-11006B) M12x1.50x146.5mm (x10)	JD612  (x4) (50-350226-00) JD275  (x2) 31-027180-00	JP078 (50-027793-00)	JJ614 (31-027798-00)	HR817  24-30614-78/0	 NF637  48x65x10mm, FPM (50-306222-50)  NB431  90x110x12mm, FPM (50-306091-50)		NA5263 [42]	 JM5118  JP078
HBS121  (22-11006B) M12x1.50x146.5mm (x10)	JD5108  (x4) (50-029152-00) JD5107   (x4) (50-029153-00) JD5183  (x2) (31-029124-00)	JM5118 50-029148-00		HR5045  24-30724-07/0	 NA5105  48x65x10mm, PTFE (50-319388-00)  NA5104  90x110x12mm, PTFE (50-319389-00)		NA5263 [42] JR5022 [45]	 JJ614



KW/PS

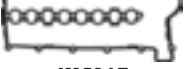

3 318 d (E46) Diesel 03/03 → 02/05 36						AC5410 (MLS), 1.45mm, 1 Hole 30-029236-00 AC5420 (MLS), 1.55mm, 2 Holes 30-029237-00 AC5430 (MLS), 1.65mm, 3 Holes 30-029238-00	CC5410 ■ ▲ 21-29236-20/0	EC5410 22-29236-00/0
3 318 d (E90) Diesel 09/05 →								
3 318 d (E91) Diesel 09/05 →								
3 318 td (E46) Diesel 03/03 → 02/05								
3 320 d (E46) Diesel 09/01 → 02/05								
3 320 d (E90) Diesel 01/05 →								
3 320 d (E91) Diesel 01/05 →								
3 320 td (E46) Diesel 09/01 → 02/05								
3 Convertible 320 Cd (E46) Diesel 02/05 →								
3 Coupe 320 Cd (E46) Diesel 11/03 →								
M 47 N 204 D4	1995	4	84.00	DOHC	85-120/ 116- 163			
M 47 N 204 D5	1995	4	84.00	DOHC	120/163			
N 47 D 20 A	1995	4	84.00	Direct Injection, DOHC	120-85/ 163- 116			
3 320 i (E30) 09/82 → 12/91 37						BD630 (Fibre) 30-023748-10 BR840 (Fibre) [249] 30-023985-10	DD631 21-23748-22/0	EX932 22-23925-03/0
3 Convertible 320 i (E30) 04/86 → 10/93								
M 20 B 20	1991	6	80.00	Injection	110/150 90/122			
M 20 B 20	1991	6	80.00	L-Jetronic	95/129			
3 320 i (E36) 01/95 → 10/99 38						BT680 (Fibre) 30-026705-10	DY570 ■ 21-26705-22/0 → 09/95 DY571 ■ 21-26705-23/0 09/95 →	EY571 22-27806-02/0 → 09/97 EW802 22-27806-01/0 10/97 →
M 52 B (20 6 S3) Vanos	1991	6	80.00	Motronic, DOHC	100- 110/ 136- 150			
M 50 B 20	1991	6	80.00	DOHC	110/150			
M 50 B 20 TU	1991	6	80.00	Injection, DOHC	110/150			
M 52 B 20	1991	6	80.00	DOHC	110/150			
3 320 i (E36) 09/90 → 02/98 39						BT680 (Fibre) 30-026705-10	DT680 ■ 21-26705-20/0 → 09/92 M 50 B 20 DY570 ■ 21-26705-22/0 → 09/95 M 52 B 20 DT681 ■ 21-26705-21/0 09/92 → M 50 B 20 DY571 ■ 21-26705-23/0 09/95 → M 52 B 20	ET681 22-27339-00/0 M 50 B20 EY571 22-27806-02/0 09/94 → 09/97 M 52 B20 EW802 22-27806-01/0 10/97 →
3 Convertible 320 i (E36) 12/93 → 04/99								
3 Coupe 320 i (E36) 03/92 → 04/99								
M 52 B (20 6 S3) Vanos	1991	6	80.00	Motronic, DOHC	100- 110/ 136- 150			
M 50 B	1991	6	80.00	Motronic, DOHC	110/150			
M 50 B 20	1991	6	80.00	DOHC	110/150			
M 50 B 20 TU	1991	6	80.00	Injection, DOHC	110/150			
M 52 B 20	1991	6	80.00	DOHC	110/150			











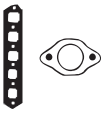

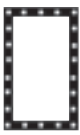

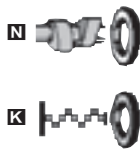



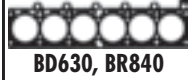
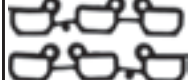











								
HBS121  [22-11006B] M12x1.50x146.5mm (x10)	JD5183  (x2) (31-029124-00)	JM5167 50-029672-00	JH5070 (31-029678-00)	HR5045  24-30724-07/0	NA5105  48x65x10mm, PTFE (50-319388-00) NA5104  90x110x12mm, PTFE (50-319389-00)	NA5263 [42] JR5022 [45]	 AC5410, AC5420, AC5430  BD630, BR840  BT680  JD492  JD493  JD497  JD5183	
HBS041  [22-11036B] M10x1.50x150mm (x14)	JD239  (31-025324-10)  JE5074 (31-025811-00)  JE555 (x2) (31-021849-10)	JN297 31-023951-20	JJ104 (31-023925-20)	HR662 	NB799  38x50x7mm, FPM (50-306223-50) NF637  48x65x10mm, FPM (50-306222-50) NB431  90x110x12mm, FPM (50-306091-50)	NA5263 [42]	 JD561  JE555  JF191  NC052	
HBS068  [22-11003B] M10x1.50x95mm (x14) HBS413  [22-11039B] M10x1.50x110mm (x14)	JD492  (x2) 50-027797-00 JD497  (x2) 31-027953-00 JD5916  [274] (31-029088-00)	HL735  24-27791-00/0 →09/95 HL736  24-27949-00/0 10/95→	JJ611 (50-027806-10)	HR280  (x2) 24-30614-75/0	NF637  48x65x10mm, FPM (50-306222-50) NB431  90x110x12mm, FPM (50-306091-50)	KK5520 [53] KK5484 [14] NA5263 [42] JR5044 [11]	 NC052  JM5167	
HBS068  [22-11003B] M10x1.50x95mm (x14) HBS413  [22-11039B] M10x1.50x110mm (x14)	JD492  (x2) 50-027797-00 M 52 B 20 JD493  (x6) 50-026702-00 →09/92 M 50 B 20 NC052  (x6) 50-026703-00 09/92→ M 50 B 20 JD497  (x2) 31-027953-00 M 52 B 20 JD561  (x3) 31-026544-10 M 50 B 20  JF191 (x2) (31-026695-10)	HL734  24-26796-00/0 (M 50 B 20 →09/92) HL735  24-27791-00/0 (M 50 B 20 09/92→) (M 52 B 20 →09/95) HL736  24-27949-00/0 10/95→ M 52 B 20	JJ611 (50-027806-10)	HR662  (x2) →09/92 HR280  24-30614-75/0 09/92→	NA5105  48x65x10mm, PTFE (50-319388-00) M 52 B 20 NF637  48x65x10mm, FPM (50-306222-50) M 50 B 20 NA5104  90x110x12mm, PTFE (50-319389-00) M 52 B 20 NB431  90x110x12mm, FPM (50-306091-50) M 50 B 20	KK5520 [53] KK5682 [53] KK5484 [14] NA5263 [42] JR5044 [11]	 JM5167  JN297  JH5070  JJ104  JJ611	

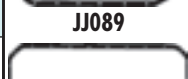

KW/PS

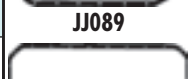

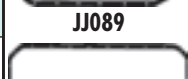
3 320 i (E46) 10/99 → 09/00 40						AC5310 (MLS) 30-029078-00	EW802 22-27806-01/0	
3 Coupe 320 Ci (E46) 08/99 → 09/00								
M 52 B (20 6 S3) Vanos	1991	6	80.00	Motronic, DOHC	100- 110/ 136- 150			
M 52 B	1991	6	80.00	Motronic, DOHC	110/150			
M 52 B 20	1991	6	80.00	DOHC	110/150			
3 320 i (E46) 03/98 → 09/00 41						AC5310 (MLS) 30-029078-00	EW802 22-27806-01/0	
M 52 B (20 6 S3) Vanos	1991	6	80.00	Motronic, DOHC	100- 110/ 136- 150			
M 52 B 20	1991	6	80.00	DOHC	110/150			
3 320 i (E90) 01/05 → 42						AC5440 (MLS), 0.4mm 30-029315-00 AC5470 (MLS), 0.7mm 30-030333-00	CC5440 21-29315-20/0 EC5410 22-29236-00/0	
3 320 i (E91) 01/05 →								
N 46 B 20	1995	4	84.00	DOHC	95-110/ 129- 150			
N 46 B 20 A/ N 46 B 20 C	1995	4	84.00	Injection, DOHC	110/150			
3 320 i (E46) 09/00 → 02/05 43						AC5310 (MLS) 30-029078-00	EW802 22-27806-01/0	
3 Convertible 320 Ci (E46) 09/00 →								
3 Coupe 320 Ci (E46) 09/00 →								
M 54 226 S1	2171	6	80.00	Injection, DOHC	125/170			
M 54 B 22	2171	6	80.00	DOHC	125/170			
3 323 i (E30) 09/83 → 08/86 44						BD630 (Fibre) 30-023748-10 BR840 (Fibre) [249] 30-023985-10	DD631 21-23748-22/0 EX932 22-23925-03/0	
M 20 B 23	2316	6	80.00	L-Jetronic, CIH	102- 110/ 139- 150			
3 M3 (E30) 06/88 → 06/91 45								
3 M3 2.3L (E30) 07/86 → 06/91								
3 M3 2.3L EVO I (E30) 10/88 → 10/90								
S 14 B 23	2302	4	93.40	Motronic, CIH	162/220			
S 14 B 23	2303	4	93.40	Injection, DOHC	143- 162/ 195- 220			
S 14 B 23	2303	4	93.40	Motronic, DOHC	147/200			











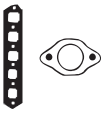

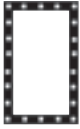

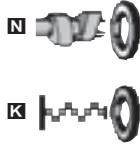





































								
HBS413 [22-11039B] M10x1.50x110mm (x14)	HA5023 [24-29075-00/0] JD5916 [274] (31-029088-00) ⊙ JF191 (x2) (31-026695-10)	HL736 24-27949-00/0	JJ611 (50-027806-10)	HR280 (x2) 24-30614-75/0	NA5105 48x65x10mm, PTFE (50-319388-00) NA5104 90x110x12mm, PTFE (50-319389-00)	KK5520 [53] KK5484 [14] JR5044 [11]	 AC5310  AC5440  BD630, BR840  HA5023  JD5428  JE5048  JE5050  JE555  JF191	
HBS068 [22-11003B] M10x1.50x95mm (x14) HBS413 [22-11039B] M10x1.50x110mm (x14)	HA5023 [24-29075-00/0] JD5916 [274] (31-029088-00) ⊙ JF191 (x2) (31-026695-10)	HL736 24-27949-00/0	JJ611 (50-027806-10)	HR280 (x2) 24-30614-75/0	NA5105 48x65x10mm, PTFE (50-319388-00) NA5104 90x110x12mm, PTFE (50-319389-00)	KK5520 [53] KK5484 [14] JR5044 [11]	 HA5023  JD5428  JE5048  JE5050  JE555  JF191	
HBS467 [22-11040B] M8x1.25x95mm (x3) M8x1.25x125mm (x3) M10x1.50x170mm (x6)	HA5024 [24-29984-00/0] JD5428 (31-029625-00) ⊙ JE5048 (31-029502-00) ⊙ JE5050 (31-029702-00) 1.30mm	HM5160 24-29591-00/0				NA5263 [42]	 JN297  JJ089  JJ104  JJ611	
HBS068 [135] [22-11003B] M10x1.50x95mm (x14) HBS413 [136] [22-11039B] M10x1.50x110mm (x14)	HA5023 [24-29075-00/0] JD5916 [274] (31-029088-00) ⊙ JE5012 (31-029096-00)	HM5069 24-29076-01/0	JJ611 (50-027806-10)	HR5062 24-30614-73/0	NA5105 48x65x10mm, PTFE (50-319388-00) NA5104 90x110x12mm, PTFE (50-319389-00)		 JN297  JJ089  JJ104  JJ611	
HBS041 [22-11036B] M10x1.50x150mm (x14)	JD239 [31-025324-10] ⊙ JE5074 (31-025811-00) ⊙ JE555 (x2) (31-021849-10)	JN297 31-023951-20	JJ104 (31-023925-20)	HR662	NB799 38x50x7mm, FPM (50-306223-50) NF637 48x65x10mm, FPM (50-306222-50) NB431 90x110x12mm, FPM (50-306091-50)	NA5263 [42]	 JJ104  JJ611	
			JJ089 (31-020447-30)	HR646 (x2) 24-30670-60/0	NC015 44x60x10mm, FPM (50-306445-50) NA5104 90x110x12mm, PTFE (50-319389-00)			



KW/PS



3 323 i (E90)					04/06 → 06/07	46	AG9540 (MLS), 1.2mm 30-030334-00 AG9550 (MLS), 1.5mm 30-030337-00	CG9540 21-30334-00/0	EG9540
3 Touring 323 i (E91)					04/06 → 06/07				
3 Cabriolet 323 i (E93)					03/07 →				
3 Coupe 323 i (E92)					06/06 →				
3 325 i (E90)					01/05 →				
3 325 xi (E90)					01/05 →				
3 Cabriolet 325 i (E93)					03/07 →				
3 Coupe 325 i (E92)					09/06 →				
3 Coupe 325 xi (E92)					09/06 →				
3 Touring 325 i (E91)					09/05 →				
3 Touring 325 xi (E91)					09/05 →				
3 2.5L (E90)					06/05 →				
N 52 B 25	2494	6	82.00	DOHC	160/218				
N52NB25A	2497	6		Injection	130/177				
N 52 B 25	2497	6	82.00	DOHC	130- 160/ 177- 218				
N 52 B 25 A	2497	6	82.00		130- 160/ 177- 218				
N 52 B 25 C	2497	6	82.00	DOHC	160/218				
3 323 i (E36)					03/95 → 02/98	47	BT690 (Fibre) 30-026706-20	DT693 21-26706-22/0 →09/95 DT692 21-26706-23/0 09/95 → 08/98	EY571 22-27806-02/0 EW802 22-27806-01/0 09/95 →
M 52 B 25 (Vanos)	2494	6	84.00	Injection, DOHC	125- 141/ 170- 192				
3 323 i (E36)					09/95 → 10/99	48	BT690 (Fibre) 30-026706-20 →08/98 AC5900 (MLS), 0.70mm 30-029100-00 09/98 → AF5190 (MLS), 1.00mm 30-030053-00 09/98 →	DT692 21-26706-23/0 →08/98 CC5900 21-29100-20/0 09/98 →	EY571 22-27806-02/0 EW802 22-27806-01/0 09/98 →
3 323 ti (E36)					08/97 → 08/00				
3 Convertible 323 i (E36)					06/95 → 04/99				
3 Coupe 323 i (E36)					03/95 → 04/99				
M 52 B 25 (Vanos)	2494	6	84.00	Injection, DOHC	125- 141/ 170- 192				
3 323 i (E46)					03/98 → 09/00	49	AC5900 (MLS), 0.70mm 30-029100-00 AF5190 (MLS), 1.00mm 30-030053-00	CC5900 21-29100-20/0	EW802 22-27806-01/0
3 Convertible 323 Ci (E46)					04/00 → 09/00				
3 Coupe 323 Ci (E46)					04/99 → 09/00				
M 52 B 25 TU	2494	6	84.00	Injection, DOHC	125/170				
M 52 B 25 (Vanos)	2494	6	84.00	Injection, DOHC	125- 141/ 170- 192				











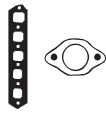

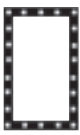

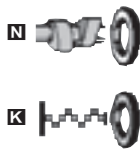

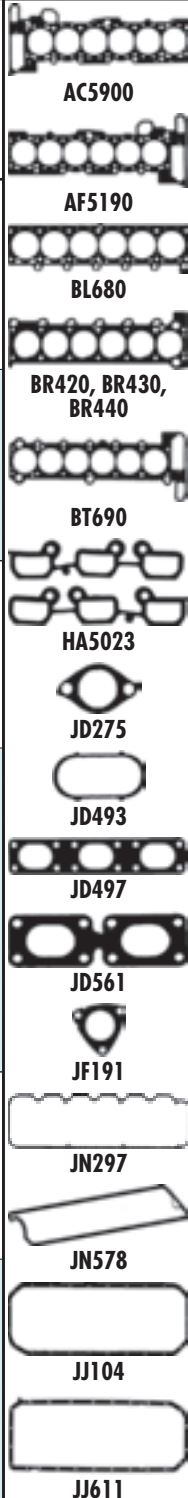











































								 AC5900
HBS468 (22-11041B) M9x1.25x95mm (x1) M9x1.25x125mm (x3) M10x1.50x125mm (x10)	JD5864  50-030336-00 JD5909  31-030374-00	HM5278  24-30168-00/0	JH5103 (31-030196-00)					 AF5190  BT690  HA5023  JD492  JD497  JF191  JJ611
HBS067  [136] (22-11007B) M10x1.50x110mm (x14) HBS068  [135] (22-11003B) M10x1.50x95mm (x14)	JD492  (x2) 50-027797-00 →08/98 HA5023   24-29075-00/0 09/98 → JD497  (x2) 31-027953-00 JD5916  [274] (31-029088-00)  JF191 (x2) (31-026695-10)	HL735  24-27791-00/0 →09/95 HL736  24-27949-00/0 09/95 →	JJ611 (50-027806-10)	HR280  (x2) 24-30614-75/0	NA5105  48x65x10mm, PTFE (50-319388-00) NA5104  90x110x12mm, PTFE (50-319389-00)	KK5520 [53] KK5484 [14] NA5263 [42] JR5044 [11]		
HBS068  [135] (22-11003B) M10x1.50x95mm (x14)	JD492  (x2) 50-027797-00 →08/98 HA5023   24-29075-00/0 09/98 → JD497  (x2) 31-027953-00 →08/98 JD5916  [274] (31-029088-00)  JF191 (x2) (31-026695-10)	HL736  24-27949-00/0	JJ611 (50-027806-10)	HR280  (x2) 24-30614-75/0	NA5105  48x65x10mm, PTFE (50-319388-00) NA5104  90x110x12mm, PTFE (50-319389-00)	KK5520 [53] KK5484 [14] NA5263 [42] JR5044 [11]		
HBS067  [136] (22-11007B) M10x1.50x110mm (x14) HBS068  [135] (22-11003B) M10x1.50x95mm (x14)	HA5023   24-29075-00/0 JD497  31-027953-00 JD5916  [274] (31-029088-00)  JF191 (x2) (31-026695-10)	HL736  24-27949-00/0	JJ611 (50-027806-10)	HR280  (x2) 24-30614-75/0	NA5105  48x65x10mm, PTFE (50-319388-00) NA5104  90x110x12mm, PTFE (50-319389-00)	KK5520 [53] KK5484 [14] JR5044 [11]		



KW/PS



3 324 d (E30) Diesel		09/85 → 08/91		50		BR420 (Fibre), 1.55mm, 1 Hole		DR422▲		EX934	
3 324 td (E30) Diesel		09/87 → 06/93				30-025304-20		21-24877-24/0		[22-23925-04/0]	
M 21 D 24 W	2443	6	80.00			63/86	BR430 (Fibre), 1.68mm, 2 Holes				
M 21 D 24	2443	6	80.00	SOHC		85/115	30-025305-20				
M 21 D 24 WA	2443	6	80.00	SOHC		85/116	BR440 (Fibre), 1.87mm, 3 Holes				
							30-025306-20				
3 325 i (E30)		09/83 → 10/93		51		BL680 (Fibre)		DL681		EX932	
3 Convertible 325 i (E30)		12/85 → 10/93				30-025354-30		21-25354-23/0		22-23925-03/0	
M 20 B 25	2494	6	84.00	Injection, SOHC		125/170			01/87 →		
M 20 B 25	2494	6	84.00	Motronic, CIH		126/171					
3 325 i (E36)		09/90 → 09/95		52		BT690 (Fibre)		DT691■		ET681	
M 50 B 25	2494	6	84.00	Injection		141/192	30-026706-20		21-26706-21/0		22-27339-00/0
M 50 B 25	2494	6	84.00	Motronic, DOHC		141/192			09/92 →		
M 50 B 25 TU	2494	6	84.00	Injection, DOHC		141/192					
3 325 i (E46)		09/00 → 02/05		53		AC5900 (MLS), 0.70mm		CC5901■		EW802	
3 325 ti (E46)		06/01 → 02/05				30-029100-00		21-29100-21/0		22-27806-01/0	
3 325 xi (E46)		09/00 → 02/05				AF5190 (MLS), 1.00mm		09/02 →			
3 Convertible 325 Ci (E46)		09/00 →				30-030053-00					
3 Coupe 325 Ci (E46)		09/00 →									
M 54 B 25	2494	6	84.00			125/ 141/ 170P/ 192S					
M 54 256 S5	2494	6	84.00	Injection, DOHC		141/192					
3 Convertible 325 i (E36)		03/93 → 03/95		54		BT690 (Fibre)		DT691■		ET681	
M 50 B 25	2494	6	84.00	Injection		141/192	30-026706-20		21-26706-21/0		22-27339-00/0
M 50 B 25 TU	2494	6	84.00	Injection, DOHC		141/192					
3 Coupe 325 i (E36)		03/92 → 04/99		55		BT690 (Fibre)		DT691■		ET681	
M 50 B 25	2494	6	84.00	Injection		141/192	30-026706-20		21-26706-21/0		22-27339-00/0
M 50 B 25	2494	6	84.00	Motronic, DOHC		141/192	→08/98		→08/98		
M 50 B 25 TU	2494	6	84.00	Injection, DOHC		141/192	AC5900 (MLS), 0.70mm		CC5900■		
							30-029100-00		21-29100-20/0		
							09/98 →		09/98 →		
							AF5190 (MLS), 1.00mm				
							30-030053-00				
							09/98 →				
3 325 e (E30)		10/83 → 12/88		56		BL680 (Fibre)		DL681		EX932	
M 20 B 27	2693	6	84.00			90/95/ 122- 129	30-025354-30		21-25354-23/0		22-23925-03/0











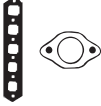

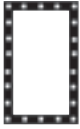

								
HBS065  (22-11002B) M11x1.50x140mm (x14)	JD275  (x6) 31-027180-00  JE5074 (31-025811-00)	JN578 50-024877-00	JJ104 (31-023925-20)	HR662  (x2)	NB799  38x50x7mm, FPM (50-306223-50) NF637  48x65x10mm, FPM (50-306222-50) NB431  90x110x12mm, FPM (50-306091-50)	NA5263 [42]		AC5900 AF5190 BL680 BR420, BR430, BR440 BT690 HA5023 JD275 JD493 JD497 JD561 JF191 JN297 JN578 JJ104 JJ611
HBS041  (22-11036B) M10x1.50x150mm (x14)	JD239  JE5074 (31-025324-10) (31-025811-00)	JN297 31-023951-20	JJ104 (31-023925-20)	HR662  (x2)	NB799  38x50x7mm, FPM (50-306223-50) NF637  48x65x10mm, FPM (50-306222-50) NB431  90x110x12mm, FPM (50-306091-50)	NA5263 [42]		BR420, BR430, BR440 BT690 HA5023 JD275 JD493 JD497 JD561 JF191 JN297 JN578 JJ104 JJ611
HBS067  [136] (22-11007B) M10x1.50x110mm (x14) HBS068  [135] (22-11003B) M10x1.50x95mm (x14)	JD493  (x6) 50-026702-00 JD561  (x3) 31-026544-10  JF191 (x2) (31-026695-10)	HL734  24-26796-00/0 →09/92 HL735  24-27791-00/0 09/92→	JJ611 (50-027806-10)	HR280  (x2) 24-30614-75/0	NF637  48x65x10mm, FPM (50-306222-50) NB431  90x110x12mm, FPM (50-306091-50)	KK5520 [53] KK5682 [53] NA5263 [42] JR5044 [11]		HA5023 JD275 JD493 JD497 JD561 JF191 JN297 JN578 JJ104 JJ611
HBS413  (22-11039B) M10x1.50x110mm (x14)	HA5023  JE5012 24-29075-00/0 JD5916  [274] (31-029088-00) (31-029096-00)	HM5069  24-29076-01/0	JJ611 (50-027806-10)	HR280  (x2) 24-30614-75/0	NA5105  48x65x10mm, PTFE (50-319388-00) NA5104  90x110x12mm, PTFE (50-319389-00)			HA5023 JD275 JD493 JD497 JD561 JF191 JN297 JN578 JJ104 JJ611
HBS067  (22-11007B) M10x1.50x110mm (x14) HBS068  (22-11003B) M10x1.50x95mm (x14)	JD493  (x6) 50-026702-00 JD497  (x6) 31-027953-00  JF191 (x2) (31-026695-10)	HL735  24-27791-00/0	JJ611 (50-027806-10)	HR280  (x2) 24-30614-75/0	NF637  48x65x10mm, FPM (50-306222-50) NB431  90x110x12mm, FPM (50-306091-50)	KK5520 [53] KK5682 [53] NA5263 [42] JR5044 [11]		HA5023 JD275 JD493 JD497 JD561 JF191 JN297 JN578 JJ104 JJ611
HBS067  [136] (22-11007B) M10x1.50x110mm (x14) HBS068  [135] (22-11003B) M10x1.50x95mm (x14)	JD493  (x6) 50-026702-00 JD561  (x3) 31-026544-10  JF191 (x2) (31-026695-10)	HL735  24-27791-00/0	JJ611 (50-027806-10)	HR280  (x2) 24-30614-75/0	NF637  48x65x10mm, FPM (50-306222-50) NB431  90x110x12mm, FPM (50-306091-50)	KK5520 [53] KK5682 [53] NA5263 [42] JR5044 [11]		HA5023 JD275 JD493 JD497 JD561 JF191 JN297 JN578 JJ104 JJ611
HBS041  (22-11036B) M10x1.50x150mm (x14)	JD239  JE5074 (31-025324-10) (31-025811-00)	JN297 31-023951-20	JJ104 (31-023925-20)	HR662  (x2)	NB799  38x50x7mm, FPM (50-306223-50) NF637  48x65x10mm, FPM (50-306222-50) NB431  90x110x12mm, FPM (50-306091-50)	NA5263 [42]		HA5023 JD275 JD493 JD497 JD561 JF191 JN297 JN578 JJ104 JJ611

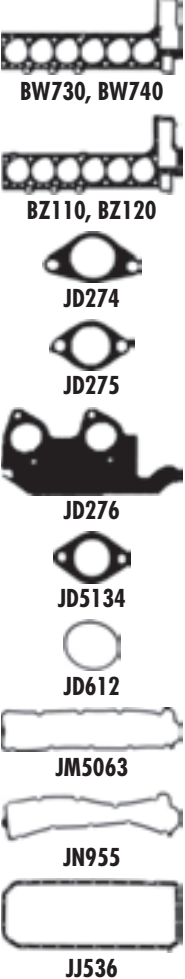
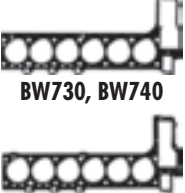
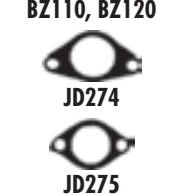

KW/PS



3 325 i (E90)		09/07 →		57		AG9290 (MLS), 1,2mm		CG9540		EG9540	
3 325 xi (E90)		09/07 →				30-030284-00		21-30334-00/0			
3 Cabriolet 325 i (E93)		03/07 →									
3 Coupe 325 i (E92)		09/07 →									
3 Coupe 325xi (E92)		09/07 →									
3 Touring 325 i (E91)		09/07 →									
3 Touring 325 xi (E91)		09/07 →									
3 Coupe 328 i (E92)		08/06 →11/07									
3 330 xi (E90)		09/07 →									
3 Touring 330 xi (E91)		09/07 →									
3 Cabriolet 330 i (E93)		03/07 →									
N52NB30B	2996	6		Injection	190/258						
N 53 B 30	2996	6	85.00	DOHC	160- 200/ 218- 272						
N53B30A	2996	6	85.00	Injection, DOHC	160- 200/ 218- 272						
N52NB30A	2996	6	85.00	Injection	187/254						
3 325 td (E36) Diesel		09/91 →02/98		58		BW730 (Fibre), 1.68mm, 2 Holes		DW731▲■		EW730	
M 51 D 25	2497	6	80.00		85/115	30-027160-20 →01/94		21-27179-22/0 →08/95		22-27096-01/0 →01/94	
						BW740 (Fibre), 1.87mm, 3 Holes 30-027161-20 →01/94		DZ121▲■ 21-29320-21/0 09/95→		EY280 22-27096-02/0 02/94→	
						BZ110 (Fibre), 1.68mm, 2 Holes 30-027395-20 01/94→					
						BZ120 (Fibre), 1.87mm, 3 Holes 30-027396-20 01/94→					
3 325 tds (E36) Diesel		01/95 →10/99		59		BZ110 (Fibre), 1.68mm, 2 Holes		DW731▲■		EY280	
M 51 D 25	2498	6	80.00	SOHC	105/143	30-027395-20		21-27179-22/0 →08/95		22-27096-02/0	
						BZ120 (Fibre), 1.87mm, 3 Holes 30-027396-20		DZ121▲■ 21-29320-21/0 09/95→			
3 325 tds (E36) Diesel		05/93 →02/98		60		BW730 (Fibre), 1.68mm, 2 Holes		DW731▲■		EW730	
M 51 D 25	2498	6	80.00	SOHC	105/143	30-027160-20 →01/94		21-27179-22/0 08/92→08/95		22-27096-01/0 →01/94	
						BW740 (Fibre), 1.87mm, 3 Holes 30-027161-20 →01/94		DZ121▲■ 21-29320-21/0 09/95→		EY280 22-27096-02/0 02/94→	
						BZ110 (Fibre), 1.68mm, 2 Holes 30-027395-20 01/94→					
						BZ120 (Fibre), 1.87mm, 3 Holes 30-027396-20 01/94→					











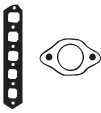

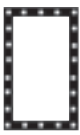

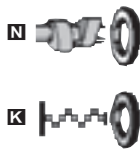















































							
HBS468 (22-11041B) M9x1.25x95mm (x1) M9x1.25x125mm (x3) M10x1.50x125mm (x10)	JD5864 ■ 50-030336-00 JD5909 ■ (x6) 31-030374-00		JH5103 (31-030196-00)				BW730, BW740  BZ110, BZ120  JD274  JD275  JD276  JD5134  JD612  JM5063  JN955  JJ536 
HBS066 ⊕ (22-11005B) M12x1.50x146.5mm (x14)	JD274 ■ (x6) 31-027183-00 →08/95 JD612 ■ (x6) (50-350226-00) 09/95→ JD275 ■ 31-027180-00 →08/92 JD276 ■ [274] 31-027181-00 JD5134 ■ (31-029321-00) 09/92→	JN955 50-027179-00 →01/96 JM5063 (50-029320-00) 01/96→	JJ536 (31-027096-20)	HR280 ■ (x2) 24-30614-75/0	NF637 ■ 48x65x10mm, FPM (50-306222-50) NB431 ■ 90x110x12mm, FPM (50-306091-50)	NA5263 [42]	
HBS066 ⊕ (22-11005B) M12x1.50x146.5mm (x14)	JD274 ■ (x6) 31-027183-00 →08/95 JD612 ■ (x6) (50-350226-00) 09/95→ JD276 ■ [274] 31-027181-00 JD5134 ■ (x4) (31-029321-00)	JN955 50-027179-00 →01/96 JM5063 (50-029320-00) 01/96→	JJ536 (31-027096-20)	HR280 ■ (x2) 24-30614-75/0	NF637 ■ 48x65x10mm, FPM (50-306222-50) NB431 ■ 90x110x12mm, FPM (50-306091-50)	NA5263 [42]	
HBS066 ⊕ (22-11005B) M12x1.50x146.5mm (x14)	JD274 ■ (x6) 31-027183-00 →08/95 JD612 ■ (x6) (50-350226-00) 09/95→ JD275 ■ 31-027180-00 →08/92 JD276 ■ [274] 31-027181-00 JD5134 ■ (x4) (31-029321-00) 09/92→	JN955 50-027179-00 →01/96 JM5063 (50-029320-00) 01/96→	JJ536 (31-027096-20)	HR280 ■ (x2) 24-30614-75/0	NF637 ■ 48x65x10mm, FPM (50-306222-50) NB431 ■ 90x110x12mm, FPM (50-306091-50)	NA5263 [42]	



KW/PS



3 325 d (E90) Diesel					09/06 →	61		CG9000▲ 21-29111-00/0	EG9000
3 Cabriolet 325 d (E93) Diesel					03/07 →				
3 Coupe 325 d (E92) Diesel					03/07 →				
3 Touring 325 d (E91) Diesel					09/06 →				
3 Cabriolet 330 d (E93) Diesel					03/07 →				
3 Coupe 330 d (E92) Diesel					09/06 →				
3 Coupe 330x d (E92) Diesel					09/06 →				
3 Touring 330 xd (E91) Diesel					09/05 →				
3 330 d (E90) Diesel					09/05 →				
3 330 d (E91) Diesel					09/05 →				
3 330 xd (E90) Diesel					09/05 →				
N57306D3	2993	6	84.00	Direct Injection	145/197				
N57N306D3	2993	6	84.00	Direct Injection	145- 170/ 197- 231				
M57 TU2 D30	2993	6	84.00	Direct Injection, DOHC	145- 173/ 197- 235				
M 57 306 D3	2993	6	84.00	Direct Injection	170/231				
3 328 i (E36)					01/95 →10/99	62	BT690 (Fibre) 30-026706-20 →08/98	DT693■○ 21-26706-22/0 →09/95	EY571 22-27806-02/0 →08/98
3 Convertible 328 i (E36)					03/95 →04/99				
3 Coupe 328 i (E36)					01/95 →04/99				
M 52 B 28/ M 52 B 28 TU	2793	6	84.00	Injection, DOHC	142/193	AC5900 (MLS), 0.70mm 30-029100-00 09/98 →	AF5190 (MLS), 1.00mm 30-030053-00 09/98 →	DT692■ 21-26706-23/0 09/95 →08/98	EW802 22-27806-01/0 09/98 →
3 328 i (E36)					01/95 →02/98 <th rowspan="2">63</th> <th rowspan="2">BT690 (Fibre) 30-026706-20</th> <th rowspan="2">DT693■○ 21-26706-22/0 →09/95</th> <th rowspan="2">EY571 22-27806-02/0</th>	63	BT690 (Fibre) 30-026706-20	DT693■○ 21-26706-22/0 →09/95	EY571 22-27806-02/0
M 52 B 28/ M 52 B 28 TU	2793	6	84.00	Injection, DOHC	142/193				
3 328 i (E46)					02/98 →06/00 <th rowspan="2">64</th> <th rowspan="2">BT690 (Fibre) 30-026706-20 →08/98</th> <th rowspan="2">DT692■ 21-26706-23/0 →08/98</th> <th rowspan="2">EY571 22-27806-02/0 →08/98</th>	64	BT690 (Fibre) 30-026706-20 →08/98	DT692■ 21-26706-23/0 →08/98	EY571 22-27806-02/0 →08/98
3 Coupe 328 Ci (E46)					04/99 →06/00				
M 52 B 28	2793	6	84.00	Injection, DOHC	142/193	AC5900 (MLS), 0.70mm 30-029100-00 09/98 →	AF5190 (MLS), 1.00mm 30-030053-00 09/98 →	CC5900■ 21-29100-20/0 09/98 →	EW802 22-27806-01/0 09/98 →











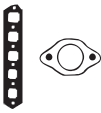

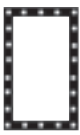

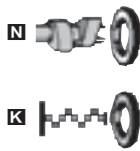

								 AC5900
HBS066  [136] (22-11005B) M12x1.50x146.5mm (x14)	JD5108  (x3) (50-029152-00) JD5107    (x3) (50-029153-00)	JM5106 50-029149-00		PA5016 (x24) 50-307240-70	NA5103  55x68x8mm, PTFE (50-319391-00) LK5007  [3] 90x173x24mm, PTFE (50-319455-00)			 AF5190  BT690  HA5023  JD492  JD497  JD5107  JD5108  JF191
HBS067  [136] (22-11007B) M10x1.50x110mm (x14) HBS068  [135] (22-11003B) M10x1.50x95mm (x14)	JD492  (x2) 50-027797-00 →08/98 HA5023    24-29075-00/0 09/98→ JD5916  [274] (31-029088-00) JD497  (x2) 31-027953-00 09/95→08/98  (31-026695-10)	HL735  24-27791-00/0 →09/95 HL736  24-27949-00/0 09/95→	JJ611 (50-027806-10)	HR280  (x2) 24-30614-75/0	NA5105  48x65x10mm, PTFE (50-319388-00) NA5104  90x110x12mm, PTFE (50-319389-00)	KK5520 [53] KK5484 [14] NA5263 [42] JR5044 [11]	 JM5106  JJ611	
HBS067  [136] (22-11007B) M10x1.50x110mm (x14) HBS068  [135] (22-11003B) M10x1.50x95mm (x14)	JD492  (x2) 50-027797-00 JD497  (x2) 31-027953-00  (31-026695-10)	HL735  24-27791-00/0 →09/95 HL736  24-27949-00/0 09/95→	JJ611 (50-027806-10)	HR280  (x2) 24-30614-75/0	NA5105  48x65x10mm, PTFE (50-319388-00) NA5104  90x110x12mm, PTFE (50-319389-00)	KK5520 [53] KK5484 [14] NA5263 [42] JR5044 [11]		
HBS067  [136] (22-11007B) M10x1.50x110mm (x14) HBS068  [135] (22-11003B) M10x1.50x95mm (x14)	JD492  (x2) 50-027797-00 →08/98 HA5023    24-29075-00/0 09/98→ JD497  (x2) 31-027953-00 →08/98 JD5916  [274] (31-029088-00)  (31-026695-10)	HL735  24-27791-00/0 →09/95 HL736  24-27949-00/0 09/95→	JJ611 (50-027806-10)	HR280  (x2) 24-30614-75/0	NF637  48x65x10mm, FPM (50-306222-50) NB431  90x110x12mm, FPM (50-306091-50)	KK5520 [53] KK5484 [14] JR5044 [11]		

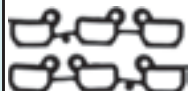

KW/PS

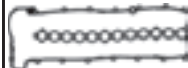

3 328 i (E90)						07/05 → 11/07	65	AG9290 (MLS), 1,2mm	CG9540	EG9540
3 330 i (E90)						01/05 →		30-030284-00	21-30334-00/0	
3 330 xi (E90)						01/05 →				
3 Touring 330 i (E91)						09/05 →				
3 Touring 330 xi (E91)						09/05 →				
N52NB30A	2996	6	85.00	Injection	187/254					
N 52 B 30 A	2996	6	85.00	DOHC	190- 195/ 258- 265					
N 52 B 30	2996	6	85.00	DOHC	190- 200/ 258- 272					
3 330 i (E90)						09/07 →	66	AG9290 (MLS), 1,2mm	CG9540	EG9540
3 Cabriolet 330 i (E93)						03/07 →		30-030284-00	21-30334-00/0	
3 Coupe 330 i (E92)						09/06 →				
3 Coupe 330 xi (E92)						09/06 →				
3 Touring 330 i (E91)						09/07 →				
N 53 B 30	2996	6	85.00	DOHC	160- 200/ 218- 272					
N53B30A	2996	6	85.00	Injection, DOHC	160- 200/ 218- 272					
N 52 B 30 A	2996	6	85.00	DOHC	190- 195/ 258- 265					
3 330 i (E46)						06/00 → 02/05	67	AC5900 (MLS), 0.70mm	CC5901	EW802
3 330 xi (E46)						06/00 → 02/05		30-029100-00	21-29100-21/0	22-27806-01/0
3 Convertible 330 Ci (E46)						06/00 →		AF5190 (MLS), 1.00mm	09/02 →	
3 Coupe 330 Ci (E46)						06/00 →		30-030053-00		
M 54 306 S3	2979	6	84.00	Injection, DOHC	163- 170/ 222- 231					
M 54 B 30	2979	6	84.00	Injection, DOHC	170/231					
3 330 d (E46) Diesel						10/99 → 02/05	68	BZ660 (MLS), 1.45mm, 1 Hole	DZ660	EZ660
3 330 xd (E46) Diesel						06/00 → 02/05		30-028559-00	21-29149-20/0	22-29108-00/0
M 57 D 30	2926	6	84.00		135/184		BZ670 (MLS), 1.55mm, 2 Holes 30-028560-00 BZ680 (MLS), 1.65mm, 3 Holes 30-028561-00 AB5980 (MLS), 1.80mm 30-029183-00			
3 330 d (E46) Diesel						03/03 → 02/05	69	AG9000 (MLS), 1.45mm, 1 Hole	CG9000	EG9000
3 330 xd (E46) Diesel						03/03 → 02/05		30-029111-00	21-29111-00/0	
3 Convertible 330 Cd (E46) Diesel						08/05 →		AG9010 (MLS), 1.55mm, 2 Holes 30-029112-00		
3 Coupe 330 Cd (E46) Diesel						03/03 →		AG9020 (MLS), 1.65mm, 3 Holes 30-029113-00		
M 57 N 306 D2	2993	6	84.00	DOHC	150/204					











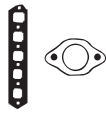

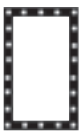

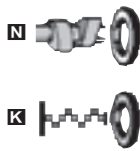







































								 AB5980
HBS468 (22-11041B) M9x1.25x95mm (x1) M9x1.25x125mm (x3) M10x1.50x125mm (x10)	JD5864 ■ 50-030336-00 JD5909 ■ 31-030374-00							 AC5900  AF5190  BZ660, BZ670, BZ680  HA5023  JD5107  JD5108  JD5183  JM5106  JH5049  JJ611
HBS468 (22-11041B) M9x1.25x95mm (x1) M9x1.25x125mm (x3) M10x1.50x125mm (x10)	JD5864 ■ 50-030336-00 JD5909 ■ (x6) 31-030374-00		JH5103 (31-030196-00)					
HBS413 ⊕ (22-11039B) M10x1.50x110mm (x14)	HA5023 ■ ■ 24-29075-00/0 JD5916 ■ [274] (31-029088-00) ⊕ JE5012 (x2) (31-029096-00)	HM5069 ■ 24-29076-01/0 09/02→	JJ611 (50-027806-10)	HR5062 ■ 24-30614-73/0	NA5105 ■ 48x65x10mm, PTFE (50-319388-00) NA5104 ■ 90x110x12mm, PTFE (50-319389-00)			
HBS066 ⊕ (22-11005B) M12x1.50x146.5mm (x14)	JD5108 ■ (x6) (50-029152-00) JD5107 ■ ■ (x6) (50-029153-00) JD5183 ■ (x3) (31-029124-00)	JM5106 50-029149-00	JH5049 (31-029108-00)	PA5016 (x24) 50-307240-70	NA5103 ■ 55x68x8mm, PTFE (50-319391-00) NA5104 ■ 90x110x12mm, PTFE (50-319389-00)			
HBS066 ⊕ (22-11005B) M12x1.50x146.5mm (x14)	JD5108 ■ (x3) (50-029152-00) JD5107 ■ ■ (x3) (50-029153-00)	JM5106 50-029149-00		PA5016 (x24) 50-307240-70	NA5103 ■ 55x68x8mm, PTFE (50-319391-00) LK5007 ■ [3] 90x173x24mm, PTFE (50-319455-00)			



KW/PS



3 335 i (E90) 09/06 → 70				AH5120 (MLS)			
3 335 xi (E90) 09/07 →							
3 Cabriolet 335 i (E93) 03/07 →							
3 Coupe 335 i (E92) 09/06 →							
3 Coupe 335 xi (E92) 09/06 →							
3 Touring 335 i (E91) 09/06 →							
3 Touring 335 xi (E91) 09/07 →							
N54B30B	2979	6	84.00	Injection, DOHC	225/306		
N 54 B 30 A	2996	6	84.00	Injection, DOHC			
5 523 i (E60) 07/05 → 71				AG9540 (MLS), 1.2mm		CG9540	EG9540
5 Touring 523 i (E61) 07/05 →				30-030334-00		21-30334-00/0	
5 525 i (E60) 07/03 →				AG9550 (MLS), 1.5mm			
5 525 xi (E60) 07/05 →				30-030337-00			
5 Touring 525 i (E61) 07/05 →							
5 Touring 525 xi (E61) 07/05 →							
N 52 B 25	2494	6	82.00	DOHC	130/175		
N 52 B 25	2497	6	82.00	DOHC	130- 160/ 177- 218		
N 52 B 25 A	2497	6	82.00		130- 160/ 177- 218		
5 518 (E28) 06/81 → 08/84 72				BC920 (Fibre)		DC921	
M 10 B 18	1766	4	89.00	Carburettor, CIH	66/90	21-23685-52/0 DC929	
						<i>(21-23685-48/0)</i>	
5 518 i (E28) 09/83 → 12/87 73				BC920 (Fibre)		DC92B	
M 10 B 18	1766	4	89.00	L-Jetronic, CIH	75-77/ 102- 105	21-23685-46/0	
5 518 i (E34) 08/89 → 01/97 74				BR830 (Fibre)		DR831	
5 518 g (E34) 11/95 → 06/96				30-026068-20			
M 43 B 18	1796	4	84.00	Injection	85/116		
5 518 i (E34) 08/89 → 09/95 75				BR830 (Fibre)		DR830	ER830
M 40 B 18	1796	4	84.00	Injection	83/113	21-26068-21/0	22-26160-00/0
5 520 i (E60) 09/07 → 76							
5 Touring 520 i (E61) 09/07 →							
N43B20A	1995	4	84.00	Injection, DOHC	96-125/ 131- 170		











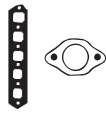

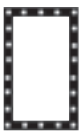

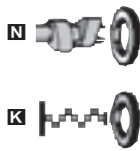











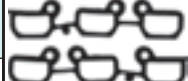















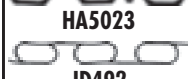

































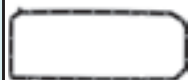













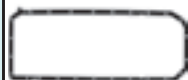











								 BC920
		JD5864  50-030336-00		JH5103 (31-030196-00)				 BP610
								 BR830
								 JD071
								 JD243
HBS468 (22-11041B) M9x1.25x95mm (x1) M9x1.25x125mm (x3) M10x1.50x125mm (x10)	JD5864  50-030336-00 JD5909  31-030374-00	HM5278  24-30168-00/0	JH5103 (31-030196-00)					 JD283
								 JD608
								 JD611
								 JE5019
HBS070  (22-11035B) M12x1.75x157mm (x10)	JD071  [274] (31-024675-10)	JN299 (31-020446-20)	JJ089 (31-020447-30)	HR569  24-30667-00/0	NB432  35x55x12mm, ACM (50-306695-50) NB431  90x110x12mm, FPM (50-306091-50)	NA5263 [42]		 JN299
HBS070  (22-11035B) M12x1.75x157mm (x10)		JN299 (31-020446-20)	JJ089 (31-020447-30)	HR569  24-30667-00/0	NB432  35x55x12mm, ACM (50-306695-50) NB431  90x110x12mm, FPM (50-306091-50)	NA5263 [42]		 JN698
HBS069  (22-11004B) M10x1.50x95mm (x10)	JD608  (x2) (31-027565-00) →09/95 JD283  (31-026152-10) JD611  (x2) (31-028409-00) 09/95 → JD243  [274] 31-027845-00  JE5019 (31-026163-00)	JP079 50-028394-00 HL733  (24-26539-00/0)	JJ537 (31-026160-10) →09/95 JJ612 (50-028405-00) 09/95 →	HR646  24-30670-60/0	NA5099  44x60x10mm, PTFE (50-319382-00) NB431  90x110x12mm, FPM (50-306091-50)	JR5031 [11] JR5046 [11]		 JP079
HBS069  (22-11004B) M10x1.50x95mm (x10)	JD189   (x2) (31-026153-00) JD283  (31-026152-10) JD243  [274] 31-027845-00  JE5019 (31-026163-00)	JN698 50-026154-10	JJ537 (31-026160-10)	HR646  24-30670-60/0	NB799  38x50x7mm, FPM (50-306223-50) NB980  42x52x7.5mm, FPM (50-306661-50) NB431  90x110x12mm, FPM (50-306091-50)	NA5263 [42]		 JJ089
								 JJ537
								 JJ612
	JD5909  (x4) 31-030374-00							



KW/PS



5 520 i (E28)		12/86 → 06/90		77		BD630 (Fibre)		DD631		EX932	
5 520 i (E34)		01/88 → 08/91				30-023748-10		21-23748-22/0		22-23925-03/0	
M 20 B 20	1990	6			110/150						
	1991	6	80.00	Injection	90/122		BR840 (Fibre) [249]				
							30-023985-10				
5 520 i (E28)		06/81 → 12/87		78		BD630 (Fibre)		DD630		EX932	
M 20 B 20	1991	6	80.00	Injection	90/122		30-023748-10	21-23748-23/0		22-23925-03/0	
M 20 B 20	1991	6	80.00	Motronic	95/129		BR840 (Fibre) [249]	→ 08/82			
							30-023985-10	DD631	21-23748-22/0		
								09/82 →			
5 520 i (E34)		11/91 → 01/97		79		BT680 (Fibre)		DT680		ET681	
5 520 i 24V (E34)		09/89 → 09/95				30-026705-10		21-26705-20/0 <th colspan="2">22-27339-00/0</th>		22-27339-00/0	
M 50 B	1991	6	80.00	Motronic, DOHC	110/150			→ 09/92			
M 50 B 20	1991	6	80.00	DOHC	110/150			DT681	21-26705-21/0		
M 50 B 20 TU	1991	6	80.00	Injection, DOHC	110/150			09/92 →			
5 520 i (E39)		04/99 → 05/04		80		AC5310 (MLS)				EW802	
M 52 B (20 6 S3)	1991	6	80.00	Motronic, DOHC	100-		30-029078-00				22-27806-01/0
Vanos					110/ 136- 150						
5 520 i (E39)		01/96 → 09/00		81		BT680 (Fibre)		DY571		EY571	
M 52 B (20 6 S3)	1991	6	80.00	Motronic, DOHC	100-		30-026705-10	21-26705-23/0		22-27806-02/0	
Vanos					110/ 136- 150		→ 09/98	→ 08/98		→ 09/97	
							AC5310 (MLS)			EW802	
M 52 B	1991	6	80.00	Motronic, DOHC	110/150		30-029078-00			22-27806-01/0	
M 52 B 20	1991	6	80.00	DOHC	110/150		09/98 →			10/97 →	
5 520 i (E39)		01/97 → 09/00		82		BT680 (Fibre)		DY571		EY571	
M 52 B (20 6 S3)	1991	6	80.00	Motronic, DOHC	100-		30-026705-10	21-26705-23/0		22-27806-02/0	
Vanos					110/ 136- 150		→ 09/98	→ 08/98		→ 09/97	
							AC5310 (MLS)			EW802	
M 52 B	1991	6	80.00	Motronic, DOHC	110/150		30-029078-00			22-27806-01/0	
M 52 B 20	1991	6	80.00	DOHC	110/150		09/98 →			10/97 →	
5 520 i (E39)		09/00 → 05/04		83		AC5310 (MLS)				EW802	
M 54 B 22	2171	6	80.00	DOHC	125/170		30-029078-00				22-27806-01/0











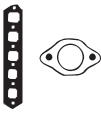

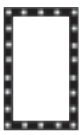

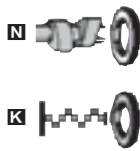









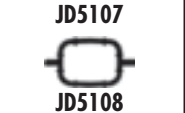



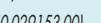

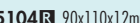









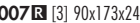

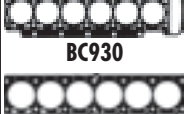







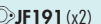



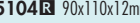
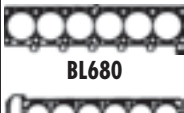
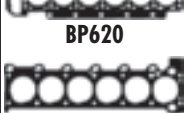









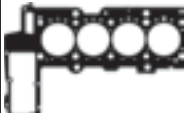



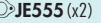

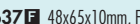
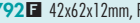
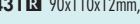

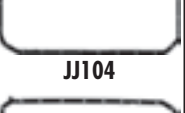





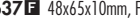



								 AC5310
HBS041  (22-11036B) M10x1.50x150mm (x14)	JD239  (31-025324-10)  (31-025811-00)  (31-021849-10)	JN297 31-023951-20	JJ104 (31-023925-20)	HR662 	NA NB799  38x50x7mm, FPM (50-306223-50) NF637  48x65x10mm, FPM (50-306222-50) NB431  90x110x12mm, FPM (50-306091-50)	NA5263 [42]	 BD630, BR840  BT680  HA5023  JD492  JD493  JD497  JD561  JE555  JF191  NC052	
HBS041  (22-11036B) M10x1.50x150mm (x14)	JD239  (31-025324-10)  (31-025811-00)  (31-021849-10)	JN297 31-023951-20	JJ104 (31-023925-20)	HR662 	NA NB799  38x50x7mm, FPM (50-306223-50) NF637  48x65x10mm, FPM (50-306222-50) NB431  90x110x12mm, FPM (50-306091-50)	NA5263 [42]	 HA5023  JD492  JD493  JD497  JD561  JE555  JF191  NC052	
HBS068  (22-11003B) M10x1.50x95mm (x14)	JD493  (x6) 50-026702-00 →09/92 NC052  (x6) 50-026703-00 09/92 → JD561  (x3) 31-026544-10  (31-026695-10)	HL734  24-26796-00/0 →09/92 HL735  24-27791-00/0 09/92 →	JJ611 (50-027806-10)	HR662  (x2) →09/92 HR280  (x2) 24-30614-75/0 09/92 →	NF637  48x65x10mm, FPM (50-306222-50) NB431  90x110x12mm, FPM (50-306091-50)	KK5520 [53] KK5682 [53] NA5263 [42] JR5044 [11]	 JD497  JD561  JE555  JF191  NC052	
HBS413  (22-11039B) M10x1.50x110mm (x14)	HA5023   24-29075-00/0 JD5916  [274] (31-029088-00)  (31-026695-10)	HL736  24-27949-00/0	JJ611 (50-027806-10)	HR280  (x2) 24-30614-75/0	NA5105  48x65x10mm, PTFE (50-319388-00) NA5104  90x110x12mm, PTFE (50-319389-00)	KK5520 [53] KK5484 [14] JR5044 [11]	 JN297  JJ104  JJ611	
HBS067  [136] (22-11007B) M10x1.50x110mm (x14) HBS068  [135] (22-11003B) M10x1.50x95mm (x14)	JD492  (x2) 50-027797-00 →08/98 HA5023   24-29075-00/0 09/98 → JD497  (x2) 31-027953-00 →08/98 JD5916  [274] (31-029088-00)  (31-026695-10)	HL736  24-27949-00/0 →08/98	JJ611 (50-027806-10)	HR280  (x2) 24-30614-75/0	NA5105  48x65x10mm, PTFE (50-319388-00) NA5104  90x110x12mm, PTFE (50-319389-00)	KK5520 [53] KK5484 [14] NA5263 [42] JR5044 [11]	 JJ104  JJ611	
HBS067  [136] (22-11007B) M10x1.50x110mm (x14) HBS068  [135] (22-11003B) M10x1.50x95mm (x14)	JD492  (x2) 50-027797-00 →08/98 HA5023   24-29075-00/0 09/98 → JD497  (x2) 31-027953-00 →08/98 JD5916  [274] (31-029088-00)  (31-026695-10)	HL736  24-27949-00/0 →08/98	JJ611 (50-027806-10)	HR280  (x2) 24-30614-75/0	NA5105  48x65x10mm, PTFE (50-319388-00) NA5104  90x110x12mm, PTFE (50-319389-00)	KK5520 [53] KK5484 [14] NA5263 [42] JR5044 [11]		
HBS067  [136] (22-11007B) M10x1.50x110mm (x14) HBS068  [135] (22-11003B) M10x1.50x95mm (x14)	HA5023   24-29075-00/0 JD5916  [274] (31-029088-00)  (31-029096-00)	HM5069  24-29076-01/0	JJ611 (50-027806-10)	HR5062  24-30614-73/0	NA5105  48x65x10mm, PTFE (50-319388-00) NA5104  90x110x12mm, PTFE (50-319389-00)	NA5263 [42]		

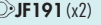

KW/PS

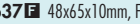
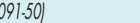

5 520 i (E60)		07/03 →		84		AC5310 (MLS)		EW802	
5 520 i (E61)		06/04 →				30-029078-00		22-27806-01/0	
M 54 226 S1	2171	6	80.00	Injection, DOHC	125/170				
M 54 B 22	2171	6	80.00	DOHC	125/170				
5 520 d (E39) Diesel		02/00 → 09/03		85		BZ500 (MLS), 1.45mm, 1 Hole		DZ661▲■	
M 47 204 D1	1951	4	84.00	DOHC	85-100/ 116- 136	30-028458-00		21-29148-20/0	
M 47 D 20	1951	4	84.00	DOHC	100/136	30-028459-00		22-29155-00/0	
						30-028460-00			
						AC5300 (MLS), 1.80mm			
						30-029182-00			
5 520 d (E60) Diesel		07/05 →		86		AC5410 (MLS), 1.45mm, 1 Hole		CC5410■▲	
5 520 d (E61) Diesel		07/05 →				30-029236-00		21-29236-20/0	
M 47 N 204 D5	1995	4	84.00	DOHC	120/163	30-029237-00		22-29236-00/0	
N 47 D 20 A	1995	4	84.00	Direct Injection, DOHC	120-85/ 163- 116	30-029238-00			
5 523 i (E39)		11/95 → 09/00		87		BT690 (Fibre)		DT692■	
M 52 B 25 TU	2494	6	84.00	Injection, DOHC	125/170	30-026706-20		21-26706-23/0	
M 52 B 25 (Vanos)	2494	6	84.00	Injection, DOHC	125- 141/ 170- 192	→08/98		→08/98	
						AC5900 (MLS), 0.70mm		CC5900■	
						30-029100-00		21-29100-20/0	
						08/98 →		09/98 →	
						AF5190 (MLS), 1.00mm		22-27806-02/0	
						30-030053-00		→08/98	
						09/98 →		22-27806-01/0	
5 524 d (E28) Diesel		03/86 → 12/87		88		BR420 (Fibre), 1.55mm, 1 Hole		DR422▲	
5 524 td (E28) Diesel		09/83 → 12/87				30-025304-20		21-24877-24/0	
5 524 td (E34) Diesel		03/88 → 09/95				BR430 (Fibre), 1.68mm, 2 Holes		(22-23925-04/0)	
M 21 D 24 W	2443	6	80.00		63/86	30-025305-20			
M 21 D 24	2443	6	80.00	SOHC	85/115	BR440 (Fibre), 1.87mm, 3 Holes			
M 21 D 24 WA	2443	6	80.00	SOHC	85/116	30-025306-20			
5 525 i (E28)		06/81 → 12/87		89		BC930 (Fibre)		DC935	
M 30 B 25	2494	6	86.00	Injection	110/150	30-023686-20		21-23686-32/0	
						BP620 (Fibre) [249]			
						30-023979-10			
5 525 i (E34)		01/88 → 08/91		90		BL680 (Fibre)		DL681	
M 20 B 25	2494	6	84.00	Motronic, CIH	126/171	30-025354-30		21-25354-23/0	
								22-23925-03/0	
5 525 i (E34)		11/91 → 01/97		91		BT690 (Fibre)		DT691■	
M 50 B 25	2494	6	84.00	Injection	141/192	30-026706-20		21-26706-21/0	
M 50 B 25 TU	2494	6	84.00	Injection, DOHC	141/192			22-27339-00/0	











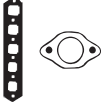

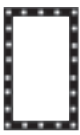

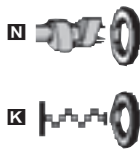

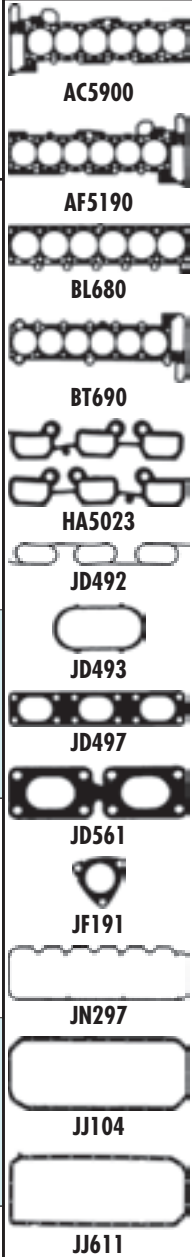



































								
HBS413  (22-11039B) M10x1.50x110mm (x14)	HA5023  24-29075-00/0	HM5069  24-29076-01/0	JJ611 (50-027806-10)	HR5062  24-30614-73/0	NA5105  48x65x10mm, PTFE (50-319388-00) NA5104  90x110x12mm, PTFE (50-319389-00)			 AC5300  JD497  JD5107  JD5108
HBS121  (22-11006B) M12x1.50x146.5mm (x10)	JD5108  (x4) (50-029152-00) JD5107  (x4) (50-029153-00) JD5183  (x2) (31-029124-00)	JM5118 50-029148-00		HR5045  24-30724-07/0	NA5105  48x65x10mm, PTFE (50-319388-00) NA5104  90x110x12mm, PTFE (50-319389-00)	NA5263 [42] JR5022 [45]		 AC5310  AC5410, AC5420, AC5430  JD5183  JD561  JE555
HBS121  (22-11006B) M12x1.50x146.5mm (x10)	JD5183  (x2) (31-029124-00)	JM5167 50-029672-00	JH5070 (31-029678-00)	HR5045  24-30724-07/0	NA5103  55x68x8mm, PTFE (50-319391-00) LK5007  [3] 90x173x24mm, PTFE (50-319455-00)	JR5022 [45]		 AF5190  BC930  JM5118
HBS067  [136] (22-11007B) M10x1.50x110mm (x14) HBS068  [135] (22-11003B) M10x1.50x95mm (x14)	JD492  50-027797-00 →08/98 HA5023  24-29075-00/0 09/98 → JD497  (x2) 31-027953-00 →08/98 JDS916  [274] (31-029088-00)  (x2) (31-026695-10)	HL736  24-27949-00/0	JJ611 (50-027806-10)	HR280  (x2) 24-30614-75/0	NA5105  48x65x10mm, PTFE (50-319388-00) NA5104  90x110x12mm, PTFE (50-319389-00)	KK5520 [53] KK5484 [14] NA5263 [42] JR5044 [11]		 BL680  BP620  JN297  JN542
HBS065  (22-11002B) M11x1.50x140mm (x14)	JD275  (x6) 31-027180-00  (x2) (31-025811-00)	JN578 50-024877-00	JJ104 (31-023925-20)	HR662  (x2)	NB799  38x50x7mm, FPM (50-306223-50) NF637  48x65x10mm, FPM (50-306222-50) NB431  90x110x12mm, FPM (50-306091-50)	NA5263 [42]		 BZ500, BZ510, BZ520  JH5070
HBS071  (22-11003B) M12x1.75x157mm (x14)	JC929  (x6) (31-024376-10)  (x2) (31-021849-10)	JN542 31-024221-30		HR569  24-30667-00/0	NF637  48x65x10mm, FPM (50-306222-50) NB792  42x62x12mm, FPM (50-306553-50) NB431  90x110x12mm, FPM (50-306091-50)	NA5263 [42]		 HA5023  JJ104
HBS041  (22-11036B) M10x1.50x150mm (x14)	JD239  (31-025324-10)  (x2) (31-025811-00)	JN297 31-023951-20	JJ104 (31-023925-20)	HR662  (x2)	NB799  38x50x7mm, FPM (50-306223-50) NF637  48x65x10mm, FPM (50-306222-50) NB431  90x110x12mm, FPM (50-306091-50)	NA5263 [42]		 JC929  JD275
HBS067  [136] (22-11007B) M10x1.50x110mm (x14) HBS068  [135] (22-11003B) M10x1.50x95mm (x14)	JD493  (x6) 50-026702-00 JD561  (x3) 31-026544-10  (x2) (31-026695-10)	HL734  24-26796-00/0 →09/92 HL735  24-27791-00/0 09/92 →	JJ611 (50-027806-10)	HR280  (x2) 24-30614-75/0	NF637  48x65x10mm, FPM (50-306222-50) NB431  90x110x12mm, FPM (50-306091-50)	KK5520 [53] KK5682 [53] KK5484 [14] NA5263 [42] JR5044 [11]		 JD492  JD493

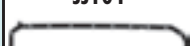

KW/PS



5 525 i (E34)				02/92 → 01/97		92		BT690 (Fibre)		DT693		EY571	
5 525 i 24V (E34)				09/89 → 09/95				30-026706-20		21-26706-22/0		22-27806-02/0	
M 52 B 25 (Vanos)	2494	6	84.00	Injection, DOHC		125- 141/ 170- 192				M 52 B 25		M 52 B 25	
M 50 B 25	2494	6	84.00	Injection		141/192				DT691		ET681	
M 50 B 25 TU	2494	6	84.00	Injection, DOHC		141/192				21-26706-21/0		22-27339-00/0	
										09/92 →		10/92 →	
										M 50 B 25			
5 525 i (E39)				09/00 → 05/04		93		AC5900 (MLS), 0.70mm		CC5901		EW802	
M 54 B 25	2494	6	84.00			125/ 141/ 170P/ 192S		30-029100-00		21-29100-21/0		22-27806-01/0	
M 54 256 S5	2494	6	84.00	Injection, DOHC		141/192		AF5190 (MLS), 1.00mm		09/02 →			
								30-030053-00					
5 525 i (E60)				09/03 →		94		AC5900 (MLS), 0.70mm		CC5901		EW802	
M 54 B 25	2494	6	84.00			125/ 141/ 170P/ 192S		30-029100-00		21-29100-21/0		22-27806-01/0	
M 54 256 S5	2494	6	84.00	Injection, DOHC		141/192		AF5190 (MLS), 1.00mm					
								30-030053-00					
5 525 i X 24V (E34)				10/91 → 09/95		95		BT690 (Fibre)		DT693		EY571	
M 52 B 25 (Vanos)	2494	6	84.00	Injection, DOHC		125- 141/ 170- 192		30-026706-20		21-26706-22/0		22-27806-02/0	
5 525 e (E28)				09/81 → 12/87		96		BL680 (Fibre)		DL681		EX932	
M 20 B 27	2693	6	84.00			90-95/ 122- 129		30-025354-30		21-25354-23/0		22-23925-03/0	











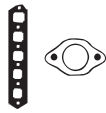

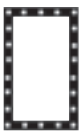

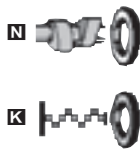



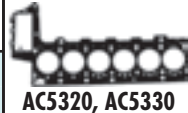



								
HBS067 [136] [22-11007B] M10x1.50x110mm (x14) HBS068 [135] [22-11003B] M10x1.50x95mm (x14)	JD492 [1] 50-027797-00 M 52 B 25 JD493 [1] (x6) 50-026702-00 M 50 B 25 JD497 [1] (x2) 31-027953-00 M 52 B 25 JD561 [1] (x3) 31-026544-10 M 50 B 25  JF191 (x2) [31-026695-10]	HL734 [1] 24-26796-00/0 →09/92 HL735 [1] 24-27791-00/0 09/92→	JJ611 [50-027806-10]	HR280 [1] (x2) 24-30614-75/0	 NA5105 [1] 48x65x10mm, PTFE [50-319388-00] M 52 B 25  NF637 [1] 48x65x10mm, FPM [50-306222-50] M 50 B 25  NA5104 [1] 90x110x12mm, PTFE [50-319389-00] M 52 B 25  NB431 [1] 90x110x12mm, FPM [50-306091-50] M 50 B 25	KK5520 [53] KK5682 [53] KK5484 [14] JR5044 [11]	AC5900  AF5190  BL680  BT690  HA5023  JD492  JD493  JD497  JD561  JF191  JN297  JJ104  JJ611	
HBS413 [1] [22-11039B] M10x1.50x110mm (x14)	HA5023 [1] [1] 24-29075-00/0 JD5916 [1] [274] [31-029088-00]  JE5012 [31-029096-00]	HM5069 [1] 24-29076-01/0	JJ611 [50-027806-10]	HR5062 [1] 24-30614-73/0	 NA5105 [1] 48x65x10mm, PTFE [50-319388-00]  NA5104 [1] 90x110x12mm, PTFE [50-319389-00]	NA5263 [42]	 JD493  JD497  JD561  JF191  JN297  JJ104  JJ611	
HBS413 [1] [22-11039B] M10x1.50x110mm (x14)	HA5023 [1] [1] 24-29075-00/0 JD5916 [1] [274] [31-029088-00]  JE5012 [31-029096-00]	HM5069 [1] 24-29076-01/0	JJ611 [50-027806-10]	HR5062 [1] 24-30614-73/0	 NA5105 [1] 48x65x10mm, PTFE [50-319388-00]  NA5104 [1] 90x110x12mm, PTFE [50-319389-00]	NA5263 [42]	 JD561  JF191  JN297  JJ104  JJ611	
HBS067 [1] [22-11007B] M10x1.50x110mm (x14) HBS068 [1] [22-11003B] M10x1.50x95mm (x14)	JD492 [1] (x2) 50-027797-00 JD497 [1] (x2) 31-027953-00  JF191 (x2) [31-026695-10]	HL735 [1] 24-27791-00/0	JJ611 [50-027806-10]	HR280 [1] (x2) 24-30614-75/0	 NA5105 [1] 48x65x10mm, PTFE [50-319388-00]  NA5104 [1] 90x110x12mm, PTFE [50-319389-00]	KK5520 [53] KK5484 [14] JR5044 [11]	 JJ104  JJ611	
HBS041 [1] [22-11036B] M10x1.50x150mm (x14)	JD239 [1] [31-025324-10]  JE5074 [31-025811-00]	JN297 31-023951-20	JJ104 [31-023925-20]	HR662 [1] (x2)	 NB799 [1] 38x50x7mm, FPM [50-306223-50]  NF637 [1] 48x65x10mm, FPM [50-306222-50]  NB431 [1] 90x110x12mm, FPM [50-306091-50]	NA5263 [42]	 JJ611	



KW/PS



5 525 i (E60) 01/07 → 97					AG9290 (MLS), 1,2mm 30-030284-00	CG9540 21-30334-00/0	EG9540				
5 525 xi (E60) 01/07 →											
5 Touring 525 i (E61) 01/07 →											
5 Touring 525 xi (E61) 01/07 →											
5 530 i (E60) 07/05 →											
5 530 xi (E60) 07/05 →											
5 Touring 530 i (E61) 07/05 →											
5 Touring 530 xi (E61) 07/05 →											
N 53 B 30	2996	6	85.00	DOHC	160- 200/ 218- 272						
N53B30A	2996	6	85.00	Injection, DOHC	160- 200/ 218- 272						
N 52 B 30 A	2996	6	85.00	DOHC	190- 195/ 258- 265						
N 52 B 30	2996	6	85.00	DOHC	190- 200/ 258- 272						
5 Touring 525 d (E61) Diesel 12/04 → 98					AG9000 (MLS), 1.45mm, 1 Hole 30-029111-00	CG9000▲ 21-29111-00/0	EG9000				
5 525 d (E60) Diesel 06/04 →											
5 525 d (E61) Diesel 06/04 →											
M 57 256 D1	2497	6	80.00	Direct Injection, DOHC	120/163	AG9010 (MLS), 1.55mm, 2 Holes 30-029112-00					
M 57 D 25 TU/	2497	6	80.00	Direct Injection, DOHC	130/177				AG9020 (MLS), 1.65mm, 3 Holes 30-029113-00		
M 57 N 256 D4											
5 525 d (E39) Diesel 02/00 → 05/04 99					AC5320 (MLS), 1.45mm, 1 Hole 30-028800-00 AC5330 (MLS), 1.55mm, 2 Holes 30-028801-00 AC5340 (MLS), 1.65mm, 3 Holes 30-028802-00 AB5990 (MLS), 1.80mm 30-029184-00	DZ660▲■ 21-29149-20/0	EZ660 22-29108-00/0				
M 57 256 D1/M 57 D 25	2497	6	80.00	Direct Injection, DOHC				120/163			
5 525 td (E34) Diesel 03/93 → 01/97 100								BW730 (Fibre), 1.68mm, 2 Holes 30-027160-20 →01/94 BW740 (Fibre), 1.87mm, 3 Holes 30-027161-20 →01/94 BZ110 (Fibre), 1.68mm, 2 Holes 30-027395-20 01/94 → BZ120 (Fibre), 1.87mm, 3 Holes 30-027396-20 01/94 →	DW731▲■ 21-27179-22/0 →01/96 DZ121▲■ 21-29320-21/0 01/96 →	EW730 22-27096-01/0 →01/94 EY280 22-27096-02/0 01/94 →	
M 51 D 25	2497	6	80.00								85/115











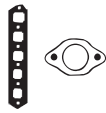

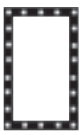

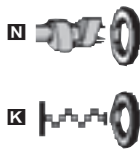















































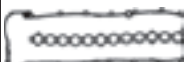

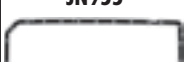

								
HBS468 (22-11041B) M9x1.25x95mm (x1) M9x1.25x125mm (x3) M10x1.50x125mm (x10)	JD5864 ■ 50-030336-00 JD5909 ■ (x6) 31-030374-00		JH5103 (31-030196-00)					 AB5990  JH5049  JJ536  AC5320, AC5330  AC5340  BM740  BW730  BZ110, BZ120  JD274  JD276  JD5107  JD5108  JD5134  JD5183  JD612  JM5063  JM5106  JN955
HBS066 ⊕ (22-11005B) M12x1.50x146.5mm (x14)	JD5108 ■ (x3) (50-029152-00) JD5107 ■ ■ (x3) (50-029153-00)	JM5106 50-029149-00		PA5016 (x24) 50-307240-70	NA5103 ■ 55x68x8mm, PTFE (50-319391-00) LK5007 ■ [3] 90x173x24mm, PTFE (50-319455-00)	NA5263 [42]		
HBS066 ⊕ (22-11005B) M12x1.50x146.5mm (x14)	JD5108 ■ (x6) (50-029152-00) JD5107 ■ ■ (x6) (50-029153-00) JD5183 ■ (x3) (31-029124-00)	JM5106 50-029149-00	JH5049 (31-029108-00)	PA5016 (x24) 50-307240-70	NA5103 ■ 55x68x8mm, PTFE (50-319391-00) NA5104 ■ 90x110x12mm, PTFE (50-319389-00)	NA5263 [42]		
HBS066 ⊕ (22-11005B) M12x1.50x146.5mm (x14)	JD274 ■ (x6) 31-027183-00 →01/96 JD612 ■ (x6) (50-350226-00) 01/96 → JD276 ■ [274] 31-027181-00 JD5134 ■ (x4) (31-029321-00)	JN955 50-027179-00 →01/96 JM5063 (50-029320-00) 01/96 →	JJ536 (31-027096-20)	HR280 ■ (x2) 24-30614-75/0	NF637 ■ 48x65x10mm, FPM (50-306222-50) NB431 ■ 90x110x12mm, FPM (50-306091-50)			



KW/PS



5 525 td (E34) Diesel				04/93 → 09/95		101				
M 51 D 25	2497	6	80.00			85/115		BW730 (Fibre), 1.68mm, 2 Holes 30-027160-20 →01/94 BW740 (Fibre), 1.87mm, 3 Holes 30-027161-20 →01/94 BZ110 (Fibre), 1.68mm, 2 Holes 30-027395-20 01/94→ BZ120 (Fibre), 1.87mm, 3 Holes 30-027396-20 01/94→	DW731▲■ 21-27179-22/0	EW730 22-27096-01/0 →01/94 EY280 22-27096-02/0 01/94→
5 525 td (E39) Diesel				01/97 → 06/03		102				
5 525 tds (E39) Diesel				01/96 → 05/04						
M 51 D 25	2497	6	80.00			85/115		BZ110 (Fibre), 1.68mm, 2 Holes 30-027395-20 BZ120 (Fibre), 1.87mm, 3 Holes 30-027396-20	DZ121▲■ 21-29320-21/0	EY280 22-27096-02/0
M 51 D 25	2498	6	80.00	SOHC		105/143				
5 525 tds (E34) Diesel				09/91 → 09/95		103				
M 51 D 25	2498	6	80.00	SOHC		105/143		BW730 (Fibre), 1.68mm, 2 Holes 30-027160-20 →01/94 BW740 (Fibre), 1.87mm, 3 Holes 30-027161-20 →01/94 BZ110 (Fibre), 1.68mm, 2 Holes 30-027395-20 01/94→ BZ120 (Fibre), 1.87mm, 3 Holes 30-027396-20 01/94→	DW730▲ 21-27179-20/0 →09/92 DW731▲■ 21-27179-22/0 09/92→	EW730 22-27096-01/0 →01/94 EY280 22-27096-02/0 01/94→
5 525 tds (E34) Diesel				12/91 → 01/97		104				
M 51 D 25	2498	6	80.00	SOHC		105/143		BW730 (Fibre), 1.68mm, 2 Holes 30-027160-20 →01/94 BW740 (Fibre), 1.87mm, 3 Holes 30-027161-20 →01/94 BZ110 (Fibre), 1.68mm, 2 Holes 30-027395-20 01/94→ BZ120 (Fibre), 1.87mm, 3 Holes 30-027396-20 01/94→	DW730▲ 21-27179-20/0 →08/92 DW731▲■ 21-27179-22/0 09/92→01/96 DZ121▲■ 21-29320-21/0 01/96→	EW730 22-27096-01/0 →01/94 EY280 22-27096-02/0 01/94→
5 525 d (E60) Diesel				01/07 →		105				
5 525 xd (E60) Diesel				01/07 →						
5 530 xd (E60) Diesel				07/05 →						
5 Touring 530 d (E61) Diesel				01/07 →						
5 Touring 530 xd (E61) Diesel				01/07 →						
5 530 d (E60) Diesel				07/03 →						
5 530 d (E61) Diesel				07/05 →						
5 530 xd (E61) Diesel				07/05 →						
M 57 306 D3	2993	6	84.00	Direct Injection		170/231			CG9000▲ 21-29111-00/0	EG9000
5 528 i (E28)				06/81 → 12/87		106				
M 30 B 28	2788	6	86.00	L-Jetronic		135/184		BC930 (Fibre) 30-023686-20 BP620 (Fibre) [249] 30-023979-10	DC935 21-23686-32/0	











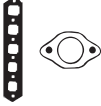

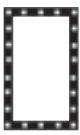

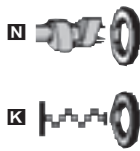









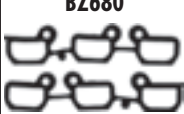

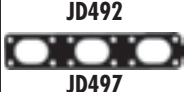





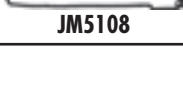











								
HBS066  (22-11005B) M12x1.50x146.5mm (x14)	JD274  (x6) 31-027183-00 JD276  [274] 31-027181-00 JD5134  (x4) (31-029321-00)	JN955 50-027179-00	JJ536 (31-027096-20)	HR280  (x2) 24-30614-75/0	NF637  48x65x10mm, FPM (50-306222-50) NB431  90x110x12mm, FPM (50-306091-50)			 BC930  BM740  BP620  BW730, BW740  BZ110, BZ120
HBS066  (22-11005B) M12x1.50x146.5mm (x14)	JD612  (x6) (50-350226-00) JD276  [274] 31-027181-00 JD5134 (31-029321-00)	JM5063 (50-029320-00)	JJ536 (31-027096-20)	HR280  (x2) 24-30614-75/0	NF637  48x65x10mm, FPM (50-306222-50) NB431  90x110x12mm, FPM (50-306091-50)	NA5263 [42]		 JC929  JD274  JD275
HBS066  (22-11005B) M12x1.50x146.5mm (x14)	JD274  (x6) 31-027183-00 JD275  (x4) 31-027180-00 →08/92 JD276  [274] 31-027181-00 JD5134  (x4) (31-029321-00) 09/92 →	JN955 50-027179-00	JJ536 (31-027096-20)	HR662  (x2) →08/92 HR280  (x2) 24-30614-75/0 09/92 →	NF637  48x65x10mm, FPM (50-306222-50) NB431  90x110x12mm, FPM (50-306091-50)			 JD276  JD5107  JD5108  JD5134  JD612  JE555
HBS066  (22-11005B) M12x1.50x146.5mm (x14)	JD274  (x6) 31-027183-00 →01/96 JD612  (x6) (50-350226-00) 01/96 → JD275  (x2) 31-027180-00 →08/92 JD276  [274] 31-027181-00 JD5134  (x4) (31-029321-00) 09/92 →	JN955 50-027179-00 →01/96 JM5063 (50-029320-00) 01/96 →	JJ536 (31-027096-20)	HR662  (x2) →08/92 HR280  (x2) 24-30614-75/0 09/92 →	NF637  48x65x10mm, FPM (50-306222-50) NB431  90x110x12mm, FPM (50-306091-50)			 JM5063  JM5106  JN542  JN955  JJ536
HBS066  (22-11005B) M12x1.50x146.5mm (x14)	JD5108  (x3) (50-029152-00) JD5107  (x3) (50-029153-00)	JM5106 50-029149-00		PA5016 (x24) 50-307240-70	NA5103  55x68x8mm, PTFE (50-319391-00) LK5007  [3] 90x173x24mm, PTFE (50-319455-00)			
HBS071  (22-11037B) M12x1.75x157mm (x14)	JC929  (x6) (31-024376-10) JE555 (x2) (31-021849-10)	JN542 31-024221-30			NB792  42x62x12mm, FPM (50-306553-50) NB431  90x110x12mm, FPM (50-306091-50)	NJ066 [2]  NJ437 [2]  NA5263 [42]		



KW/PS



5 528 i (E39)				11/95 → 09/00		107			DT692■	EY571
M 52 B 28/ M 52 B 28 TU	2793	6	84.00	Injection, DOHC	142/193	BT690 (Fibre) 30-026706-20 →09/98 AC5900 (MLS), 0.70mm 30-029100-00 09/98 →		21-26706-23/0 →08/98 CC5900■ 21-29100-20/0 09/98 →	22-27806-02/0 →08/98 EW802 22-27806-01/0 09/98 →	
5 530 i (E34)				01/88 → 08/91		108				
M 30 B 30	2988	6	89.00	Injection	145/197	BS320 (Fibre), 1.25mm				
5 530 i (E39)				09/00 → 05/04		109				
M 54 306 S3	2979	6	84.00	Injection, DOHC	163- 170/ 222- 231	AC5900 (MLS), 0.70mm 30-029100-00 AF5190 (MLS), 1.00mm 30-030053-00		CC5901■ 21-29100-21/0 09/02 →	EW802 22-27806-01/0	
M 54 B 30	2979	6	84.00	Injection, DOHC	170/231					
5 530 i (E60)				07/03 →		110				
5 530 i (E61)				06/04 →						
M 54 306 S3	2979	6	84.00	Injection, DOHC	163- 170/ 222- 231	AC5900 (MLS), 0.70mm 30-029100-00 AF5190 (MLS), 1.00mm 30-030053-00		CC5901■ 21-29100-21/0	EW802 22-27806-01/0	
M 54 B 30	2979	6	84.00	Injection, DOHC	170/231					
5 530 i V8 (E34)				09/92 → 01/97		111				
M 60 B 30	2997	8	84.00	Injection, DOHC, V8	160/218					
5 530 d (E39) Diesel				08/98 → 05/04		112				
M 57 D 30	2926	6	84.00		135/184	BZ660 (MLS), 1.45mm, 1 Hole 30-028559-00 BZ670 (MLS), 1.55mm, 2 Holes 30-028560-00 BZ680 (MLS), 1.65mm, 3 Holes 30-028561-00 AB5980 (MLS), 1.80mm 30-029183-00		DZ660▲■ 21-29149-20/0	EZ660 22-29108-00/0	
5 530 d (E60) Diesel				07/03 →		113				
5 530 d (E61) Diesel				06/04 →						
5 535 d (E60) Diesel				09/04 →						
5 535 d (E61) Diesel				09/04 →						
N 57 306 D 2	2993	6	84.00	DOHC	160/218	AG9000 (MLS), 1.45mm, 1 Hole 30-029111-00		CG9000▲ 21-29111-00/0	EG9000	
M 57 306 D4	2993	6	84.00	Direct Injection, DOHC	200/272	AG9010 (MLS), 1.55mm, 2 Holes 30-029112-00 AG9020 (MLS), 1.65mm, 3 Holes 30-029113-00				
5 535 i (E34)				01/88 → 09/95		114				
M 30 B 35	3453	6	92.00	Motronic, CIH	185/252	BL690 (Fibre) 30-024647-20		DL691 21-24647-25/0		
5 535 i, M 535 i (E28)				01/85 → 12/87		115				
M 30 B 35	3430	6	92.00	Motronic, CIH	141- 162/ 192- 220	BL690 (Fibre) 30-024647-20		DL690 21-24647-24/0		
M 30 B 35	3453	6	92.00	Motronic, CIH	185/252					

																																																			
HBS067 [136] (22-11007B) M10x1.50x110mm (x14) HBS068 [135] (22-11003B) M10x1.50x95mm (x14)	JD492 [1] 50-027797-00 →08/98 HA5023 [1] 24-29075-00/0 09/98 → JD497 (x2) 31-027953-00 →08/98 JD5916 [274] (31-029088-00)  JF191 (x2) (31-026695-10)	HL736 [1] 24-27949-00/0 →08/98	JJ611 (50-027806-10)	HR280 [x2] 24-30614-75/0	 NA5105 [1] 48x65x10mm, PTFE (50-319388-00)  NA5104 [1] 90x110x12mm, PTFE (50-319389-00)	KK5520 [53] KK5484 [14] JR5044 [11]	 AB5980  AC5900  AF5190  BL690  BS320  BT690  BZ660, BZ670, BZ680  HA5023  JC929  JD315  JD492  JD497  JD5107  JD5108  JD5146  JD5183  JE555  JF191 JM5106 JM5108	JN542 31-024221-30 JJ538 (31-026671-00) HR569 [1] 24-30667-00/0  NB792 [1] 42x62x12mm, FPM (50-306553-50)  NB431 [1] 90x110x12mm, FPM (50-306091-50)	NA5263 [42]	JN542 31-024221-30 JJ611 (50-027806-10) HR5062 [1] 24-30614-73/0  NA5105 [1] 48x65x10mm, PTFE (50-319388-00)  NA5104 [1] 90x110x12mm, PTFE (50-319389-00)	NA5263 [42]	HBS413 [1] (22-11039B) M10x1.50x110mm (x14)	HA5023 [1] 24-29075-00/0 JD5916 [274] (31-029088-00)  JE5012 (x2) (31-029096-00)	HM5069 [1] 24-29076-01/0 09/02 →	JJ611 (50-027806-10)	HR5062 [1] 24-30614-73/0  NA5105 [1] 48x65x10mm, PTFE (50-319388-00)  NA5104 [1] 90x110x12mm, PTFE (50-319389-00)	NA5263 [42]	HBS413 [1] (22-11039B) M10x1.50x110mm (x14)	HA5023 [1] 24-29075-00/0 JD5916 [274] (31-029088-00)  JE5012 (31-029096-00)	HM5069 [1] 24-29076-01/0	JJ611 (50-027806-10)	HR5062 [1] 24-30614-73/0  NA5105 [1] 48x65x10mm, PTFE (50-319388-00)  NA5104 [1] 90x110x12mm, PTFE (50-319389-00)	NA5263 [42]	HBS067 [1] (22-11007B) M10x1.50x110mm (x14)	JD5146 [137] 31-027247-10	JM5109 [1] 50-027249-00 JM5107 (x2) 50-027251-00 JM5108 [1] 50-027250-00	JH5115 (31-027255-10) JH5116 [1] (50-028471-00)	HR791 [x2] 24-30614-76/0	 NF637 [1] 48x65x10mm, FPM (50-306222-50)  NA5132 [1] 100x125x13mm, FPM (50-306622-00)	NA5263 [42]	HBS066 [1] (22-11005B) M12x1.50x146.5mm (x14)	JD5108 [x6] (50-029152-00) JD5107 [x6] (x6) (50-029153-00) JD5183 [x3] (31-029124-00)	JM5106 50-029149-00	JH5049 (31-029108-00)	PA5016 (x24) 50-307240-70  NA5103 [1] 55x68x8mm, PTFE (50-319391-00)  NA5104 [1] 90x110x12mm, PTFE (50-319389-00)	NA5263 [42]	HBS066 [1] (22-11005B) M12x1.50x146.5mm (x14)	JD5108 [x3] (50-029152-00) JD5107 [x3] (x3) (50-029153-00)	JM5106 50-029149-00	PA5016 (x24) 50-307240-70  NA5103 [1] 55x68x8mm, PTFE (50-319391-00)  LK5007 [3] 90x173x24mm, PTFE (50-319455-00)	NA5263 [42]	HBS071 [1] (22-11037B) M12x1.75x157mm (x14)	JD315 [x6] (31-025685-20)	JN542 31-024221-30 JJ538 (31-026671-00)	 NB792 [1] 42x62x12mm, FPM (50-306553-50)  NB431 [1] 90x110x12mm, FPM (50-306091-50)	NA5263 [42]	HBS071 [1] (22-11037B) M12x1.75x157mm (x14)	JC929 [x6] (31-024376-10)  JE555 (x2) (31-021849-10)	JN542 31-024221-30 JJ538 (31-026671-00)	 NB792 [1] 42x62x12mm, FPM (50-306553-50)  NB431 [1] 90x110x12mm, FPM (50-306091-50)	NA5263 [42]



KW/PS



5 535 i (E39)				04/96 → 06/03		116		AC5640 (MLS), 1.74mm		CC5350	
M 62 B	3498	8	84.00	V8	173/235	30-029389-00					
M 62 B 35	3498	8	84.00	Injection, DOHC, V8	173/235	AC5650 (MLS), 1.74mm					
M 62 B 35 TU	3498	8	84.00	Injection, DOHC, V8	175-180/238-245	30-029390-00					
M 62 B	3498	8	84.00	Motronic, DOHC, V8	180/245						
5 540 i (E34)				09/93 → 01/97		117		BX280 (Fibre)			
5 540 i V8 (E34)				09/92 → 09/95				30-027241-00			
M 60 B 40	3982	8	89.00	Injection, DOHC, V8	210/286	BX300 (Fibre) [249]					
						30-027333-00					
						BX270 (Fibre)					
						30-027240-00					
						BX290 (Fibre) [249]					
						30-027332-00					
5 540 i (E39)				04/96 → 06/03		118		AC5380 (Fibre)		CC5350	
M 62 B 44 TU	4398	8	92.00	Injection, DOHC, V8	210/286	30-027787-10					21-29383-20/0
M62448S2	4398	8	92.00		210/286	→09/97					09/98 →
M 62 B 44	4398	8	92.00	V8	210/255/286/347	AC5370 (Fibre)					
						30-027785-10					
						→09/97					
						AC5360 (MLS)					
						30-029070-00					
						09/97 →					
						AC5350 (MLS)					
						30-029069-00					
						09/97 →					
5 540 i (E39)				01/97 → 05/04		119		AC5380 (Fibre)		CC5350	
M 62 B 44 TU	4398	8	92.00	Injection, DOHC, V8	210/286	30-027787-10					21-29383-20/0
M62448S2	4398	8	92.00		210/286	→09/97					09/98 →
M 62 B 44	4398	8	92.00	V8	210/255/286/347	AC5370 (Fibre)					
						30-027785-10					
						→09/97					
						AC5360 (MLS)					
						30-029070-00					
						09/97 →					
						AC5350 (MLS)					
						30-029069-00					
						09/97 →					
5 545 i (E60)				09/03 →		120		AC5360 (MLS)			
5 545 i (E61)				06/04 →				30-029070-00			
N 62 B 44	4398	8	92.00	Injection, V8	240/326	AC5350 (MLS)					
						30-029069-00					
6 Coupe 628 CSi (E24)				09/79 → 08/87		121		BC930 (Fibre)		DC935	
M 30 B 28	2788	6	86.00	L-Jetronic	135/184	30-023686-20					21-23686-32/0
											05/81 →

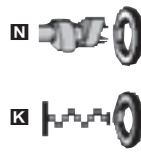
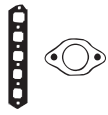

AC5370, AC5350



AC5380, AC5360



AC5640



AC5650



BC930



BX270



BX280



BX300



JC929



JD5146



JE555



JM5097



JM5108







JN300

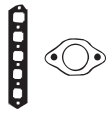

JN542

HBS067 
(22-11007B)
M10x1.50x110mm (x14)

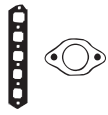

JM5109 
50-027249-00
→09/98
JM5107 (x2)
50-027251-00
JM5108 
50-027250-00
→09/98
HM5067   [138]
24-29384-00/0
09/98 →
HM5066   [139]
24-29383-00/0
09/98 →

JH5115
(31-027255-10)
JH5116 
(50-028471-00)

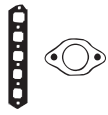
HR791  (x2)
24-30614-76/0

NF637  48x65x10mm, FPM
(50-306222-50)
NA5132  100x125x13mm, FPM
(50-306622-00)

HBS067 
(22-11007B)
M10x1.50x110mm (x14)

JM5109 
50-027249-00
JM5107 (x2)
50-027251-00
JM5108 
50-027250-00

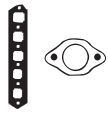

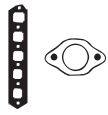

JH5115
(31-027255-10)
JH5116 
(50-028471-00)

HR791  (x2)
24-30614-76/0

NF637  48x65x10mm, FPM
(50-306222-50)
NA5132  100x125x13mm, FPM
(50-306622-00)

HBS067 
(22-11007B)
M10x1.50x110mm (x14)

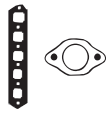
JD5146  (x3)
31-027247-10

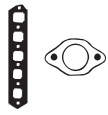
JM5109 
50-027249-00
→09/98
JM5107 (x2)
50-027251-00
→09/98
JM5108 
50-027250-00
→09/98
HM5067  
24-29384-00/0
09/98 →
HM5066  
24-29383-00/0
09/98 →



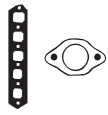

JH5115
(31-027255-10)
JH5116 
(50-028471-00)

HR791  (x2)
24-30614-76/0

NF637  48x65x10mm, FPM
(50-306222-50)
NA5132  100x125x13mm, FPM
(50-306622-00)

HBS067 
(22-11007B)
M10x1.50x110mm (x14)

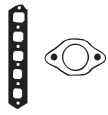

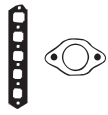
JD5146  (x3)
31-027247-10

JM5109 
50-027249-00
→09/98
JM5107 (x2)
50-027251-00
→09/98
JM5108 
50-027250-00
→09/98
HM5067  
24-29384-00/0
09/98 →
HM5066  
24-29383-00/0
09/98 →

JH5115
(31-027255-10)
JH5116 
(50-028471-00)

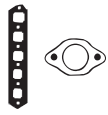
HR791  (x2)
24-30614-76/0

NF637  48x65x10mm, FPM
(50-306222-50)
NA5132  100x125x13mm, FPM
(50-306622-00)



JM5097 
(50-029384-00)
JM5096 
50-029383-00

NA5263 [42]

HBS071 
(22-11037B)
M12x1.75x157mm (x14)

JC929  (x6)
(31-024376-10)
JE555 (x2)
(31-021849-10)

JN300
→04/81
JN542
31-024221-30
05/81 →

NB792  42x62x12mm, FPM
(50-306553-50)
NB431  90x110x12mm, FPM
(50-306091-50)

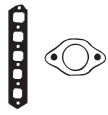
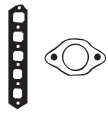
NJ066 [2] 
NJ437 [2] 
NA5263 [42]



KW/PS

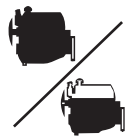

6 630 i (E63)		09/04 →		122		AG9290 (MLS), 1,2mm		CG9540		EG9540	
6 Cabriolet 630 i (E64)		09/04 →				30-030284-00		21-30334-00/0			
N 53 B 30	2996	6	85.00	DOHC		160- 200/ 218- 272					
N 52 B 30 A	2996	6	85.00	DOHC		190- 195/ 258- 265					
N 52 B 30	2996	6	85.00	DOHC		190- 200/ 258- 272					
6 Coupe 635 CSi (E24)		06/78 →08/88		123		BL690 (Fibre)		DL690			
M 30 B 35	3430	6	92.00	Motronic, CIH		160/218	30-024647-20		21-24647-24/0		
M 30 B 35	3453	6	93.40	Motronic, CIH		160/218	09/82 →		05/82 →		
M 30 B 35	3453	6	93.40	L-Jetronic, CIH		160/218					
6 Coupe 635 CSi (E24)		08/87 →05/89		124		BL690 (Fibre)		DL691			
M 30 B 35	3453	6	92.00	Motronic, CIH		185/252	30-024647-20		21-24647-25/0		
6 Coupe 635 CSi (E24)		01/85 →09/90		125		BL690 (Fibre)		DL690			
M 30 B 35	3430	6	92.00	Motronic, CIH		136/185	30-024647-20		21-24647-24/0		
M 30 B 35	3453	6	92.00	Motronic, CIH		185/252			→06/87		
									DL691		
									21-24647-25/0		
									06/87 →		
6 645 Ci (E63)		01/04 →		126		AC5360 (MLS) ■					
6 645 Ci (E64)		04/04 →				30-029070-00					
M 62 B 44 A	4398	8	92.00	Injection, DOHC, V8		235- 245/ 320- 333	AC5350 (MLS) ■				
							30-029069-00				
N 62 B 44	4398	8	92.00	Injection, V8		240/326					
7 725 tds (E38) Diesel		04/96 →11/01		127		BZ110 (Fibre), 1.68mm, 2 Holes		DZ121▲■		EY280	
M 51 D 25	2498	6	80.00	SOHC		105/143	30-027395-20		21-29320-21/0		22-27096-02/0
							BZ120 (Fibre), 1.87mm, 3 Holes				
							30-027396-20				
7 728 i (E23)		07/78 →08/86		128		BC930 (Fibre)		DC935			
M 30 B 28	2788	6	86.00	L-Jetronic		135/184	30-023686-20		21-23686-32/0		
							BP620 (Fibre) [249]		04/81 →		
							30-023979-10				
7 728 i, iL (E38)		08/95 →11/01		129		BT690 (Fibre)		DT692■		EY571	
M 52 B 28/ M 52 B 28 TU	2793	6	84.00	Injection, DOHC		142/193	30-026706-20		21-26706-23/0		22-27806-02/0
							→09/98		→08/98		→08/98
							AC5900 (MLS), 0.70mm		CC5900■		EY802
							30-029100-00		21-29100-20/0		22-27806-01/0
							09/98 →		09/98 →		09/98 →







HBS468 (22-11041B) M9x1.25x95mm (x1) M9x1.25x125mm (x3) M10x1.50x125mm (x10)	JD5864 ■ 50-030336-00 JD5909 ■ 31-030374-00		JH5013 (31-027911-00)				AC5350 AC5360 AC5900 BC930 BL690 BP620 BT690 BZ110, BZ120 HA5023 JC929 JD276 JD315 JD492 JD497 JD5134 JD612 JE555 JF191 JM5063 JM5097	JN300 JN300 JN542 JN542	JN300 01/78 → 09/80 JN542 31-024221-30 09/80 →	JN542 31-024221-30	JN542 31-024221-30	JN542 31-024221-30 → 06/87 JD315 ■ (x6) (31-025685-20) JD315 ■ (x6) (31-025685-20) 08/87 →	JM5097 ■ (50-029384-00) JM5096 ■ 50-029383-00	JJ536 (31-027096-20)	HR280 ■ (x2) 24-30614-75/0	NB792 ■ 42x62x12mm, FPM (50-306553-50) NB431 ■ 90x110x12mm, FPM (50-306091-50)	NJ066 [2] ■ NA5263 [42]	AC5350 JN300 JN542 AC5360 JH5013 AC5900 JJ536 BC930 JJ611 BL690 BP620 BT690 BZ110, BZ120 HA5023 JC929 JD276 JD315 JD492 JD497 JD5134 JD612 JE555 JF191 JM5063 JM5097
HBS071 ☒ (22-11037B) M12x1.75x157mm (x14)	JC929 ■ (x6) (31-024376-10) JE5074 (31-025811-00)	JN300 01/78 → 09/80 JN542 31-024221-30 09/80 →			NB792 ■ 42x62x12mm, FPM (50-306553-50) NB431 ■ 90x110x12mm, FPM (50-306091-50)	NJ066 [2] ■ NA5263 [42]	BT690 BZ110, BZ120 HA5023 JC929 JD276 JD315 JD492 JD497 JD5134 JD612 JE555 JF191 JM5063 JM5097											
HBS071 ☒ (22-11037B) M12x1.75x157mm (x14)	JD315 ■ (x6) (31-025685-20)	JN542 31-024221-30			NB792 ■ 42x62x12mm, FPM (50-306553-50) NB431 ■ 90x110x12mm, FPM (50-306091-50)	NA5263 [42]	BZ110, BZ120 HA5023 JC929 JD276 JD315 JD492 JD497 JD5134 JD612 JE555 JF191 JM5063 JM5097											
HBS071 ☒ (22-11037B) M12x1.75x157mm (x14)	JC929 ■ (x6) (31-024376-10) → 06/87 JD315 ■ (x6) (31-025685-20) 08/87 →	JN542 31-024221-30			NB792 ■ 42x62x12mm, FPM (50-306553-50) NB431 ■ 90x110x12mm, FPM (50-306091-50)	NA5263 [42]	HA5023 JC929 JD276 JD315 JD492 JD497 JD5134 JD612 JE555 JF191 JM5063 JM5097											
HBS066 ☒ (22-11005B) M12x1.50x146.5mm (x14)	JD612 ■ (x6) (50-350226-00) JD276 ■ [274] 31-027181-00 JD5134 ■ (31-029321-00)	JM5063 (50-029320-00)	JJ536 (31-027096-20)	HR280 ■ (x2) 24-30614-75/0	NF637 ■ 48x65x10mm, FPM (50-306222-50) NB431 ■ 90x110x12mm, FPM (50-306091-50)	NA5263 [42]	JD492 JD497 JD5134 JD612 JE555 JF191 JM5063 JM5097											
HBS071 ☒ (22-11037B) M12x1.75x157mm (x14)	JC929 ■ (x6) (31-024376-10) JE555 (x2) (31-021849-10)	JN300 → 04/81 JN542 31-024221-30 05/81 →			NB792 ■ 42x62x12mm, FPM (50-306553-50) NB431 ■ 90x110x12mm, FPM (50-306091-50)	NJ066 [2] ■ NJ437 [2] ■ NA5263 [42]	JD5134 JD612 JE555 JF191 JM5063 JM5097											
HBS067 ☒ [136] (22-11007B) M10x1.50x110mm (x14) HBS068 ☒ [135] (22-11003B) M10x1.50x95mm (x14)	JD492 ■ 50-027797-00 → 08/98 HA5023 ■ ■ 24-29075-00/0 09/98 → JD497 ■ (x2) 31-027953-00 → 08/98 JD5916 ■ [274] (31-029088-00) JF191 (x2) (31-026695-10)	HL736 ■ 24-27949-00/0 → 08/98	JJ611 (50-027806-10)	HR280 ■ (x2) 24-30614-75/0	NA5105 ■ 48x65x10mm, PTFE (50-319388-00) NA5104 ■ 90x110x12mm, PTFE (50-319389-00)	KK5520 [53] KK5484 [14] NA5263 [42] JR5044 [11]	HA5023 JC929 JD276 JD315 JD492 JD497 JD5134 JD612 JE555 JF191 JM5063 JM5097											

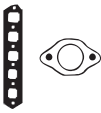

KW/PS

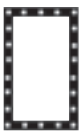

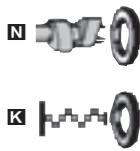
7 730 i, Li (E65, E66)		03/05 →			130	AG9290 (MLS), 1,2mm	CG9540	EG9540
N 52 B 30 A	2996	6	85.00	DOHC	190-195/ 258-265	30-030284-00	21-30334-00/0	
N 52 B 30	2996	6	85.00	DOHC	190-200/ 258-272			
7 730 i, iL (E32)		12/86 → 09/94			131	BS320 (Fibre), 1.25mm		
M 30 B 30	2988	6	89.00	Injection	145/197			
7 730 i, iL (E38)		10/94 → 11/01			132			
7 730 i, iL V8 (E32)		04/92 → 09/94						
M 60 B 30	2997	8	84.00	Injection, DOHC, V8	160/218			
7 730 i, Li (E65, E66)		03/03 →			133	AC5900 (MLS), 0.70mm	CC5901	EW802
M 54 306 S3	2979	6	84.00	Injection, DOHC	163-170/ 222-231	30-029100-00	21-29100-21/0	22-27806-01/0
M 54 B 30	2979	6	84.00	Injection, DOHC	170/231			
7 730 Ld (E65, E66) Diesel		07/05 →			134	AG9000 (MLS), 1.45mm, 1 Hole	CG9000	EG9000
M 57 306 D3	2993	6	84.00	Direct Injection	170/231	30-029111-00	21-29111-00/0	
N57N306D2	2993	6	84.00	Direct Injection, DOHC	170/231	AG9010 (MLS), 1.55mm, 2 Holes 30-029112-00 AG9020 (MLS), 1.65mm, 3 Holes 30-029113-00		
7 730 d (E38) Diesel		08/98 → 11/01			135	BZ660 (MLS), 1.45mm, 1 Hole	DZ660	EZ660
M 57 D 30	2926	6	84.00		135-142/ 184-193	30-028559-00	21-29149-20/0	22-29108-00/0
M 57 306 D1	2926	6	84.00	DOHC		BZ670 (MLS), 1.55mm, 2 Holes 30-028560-00 BZ680 (MLS), 1.65mm, 3 Holes 30-028561-00 AB5980 (MLS), 1.80mm 30-029183-00		
7 730 d (E65, E66) Diesel		10/02 →			136	AG9000 (MLS), 1.45mm, 1 Hole	CG9000	
N 57 306 D 2	2993	6	84.00	DOHC	160/218	30-029111-00 AG9010 (MLS), 1.55mm, 2 Holes 30-029112-00 AG9020 (MLS), 1.65mm, 3 Holes 30-029113-00	21-29111-00/0	
7 732 l / 733 i (E23)		05/77 → 08/86			137	BC940 (Fibre)		
M 30 B 32	3153	6	89.25	Injection	145/197	30-023687-20		
7 735 i (E23)		01/85 → 08/86			138	BL690 (Fibre)	DL690	
M 30 B 35	3430	6	92.00	Motronic, CIH	136/185	30-024647-20	21-24647-24/0	
M 30 B 35	3430	6	92.00	Motronic, CIH	141-162/ 192-220			
7 735 i (E23)		09/79 → 08/86			139	BL690 (Fibre)	DL690	
M 30 B 35	3430	6	92.00	Motronic, CIH	160/218	30-024647-20	21-24647-24/0	
M 30 B 35	3453	6	93.40	Motronic, CIH	160/218			

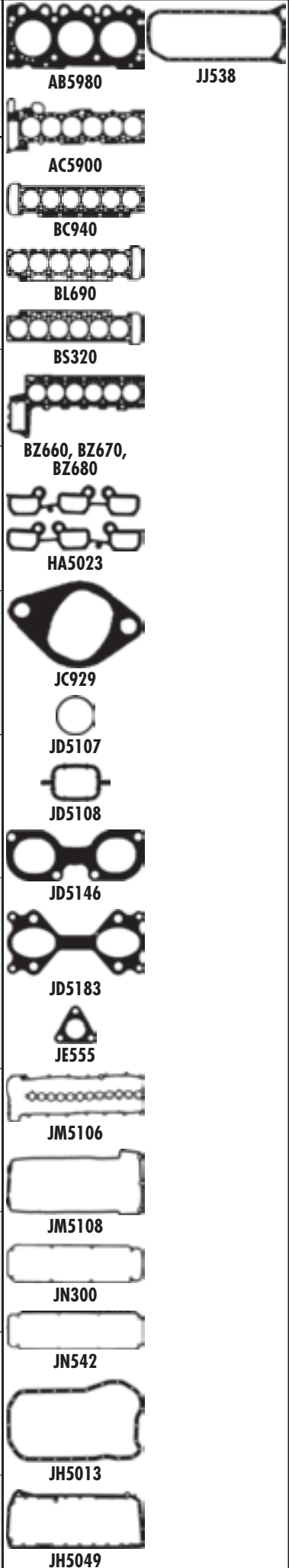
								
HBS468 (22-11041B) M9x1.25x95mm (x1) M9x1.25x125mm (x3) M10x1.50x125mm (x10)	JD5864 ■ 50-030336-00 JD5909 ■ 31-030374-00		JH5013 (31-027911-00)					AB5980 AC5900 BC940 BL690 BS320 BZ660, BZ670, BZ680 HA5023 JC929 JD5107 JD5108 JD5146 JD5183 JE555 JM5106 JM5108 JN300 JN542 JH5013 JH5049
HBS071 ⊕ (22-11037B) M12x1.75x157mm (x14)	JC929 ■ (x6) (31-024376-10)	JN542 31-024221-30	JJ538 (31-026671-00)		NA5263 [42]	NB792 ■ 42x62x12mm, FPM (50-306553-50) NB431 ■ 90x110x12mm, FPM (50-306091-50)		
HBS067 ⊕ (22-11007B) M10x1.50x110mm (x14)	JD5146 ■ [137] 31-027247-10	JM5109 ■ 50-027249-00 JM5107 (x2) 50-027251-00 JM5108 ■ 50-027250-00	JH5115 (31-027255-10) JH5116 ■ (50-028471-00)	HR791 ■ (x2) 24-30614-76/0	NA5263 [42]	NF637 ■ 48x65x10mm, FPM (50-306222-50) NA5132 ■ 100x125x13mm, FPM (50-306622-00)		
HBS413 ⊕ (22-11039B) M10x1.50x110mm (x14)	HA5023 ■ ■ 24-29075-00/0 JD5916 ■ [274] (31-029088-00)	HM5069 ■ 24-29076-01/0		HR5062 ■ 24-30614-73/0		NA5105 ■ 48x65x10mm, PTFE (50-319388-00) NA5104 ■ 90x110x12mm, PTFE (50-319389-00)		
HBS066 ⊕ (22-11005B) M12x1.50x146.5mm (x14)	JD5108 ■ (x3) (50-029152-00) JD5107 ■ ■ (x3) (50-029153-00)	JM5106 50-029149-00		PA5016 (x24) 50-307240-70	NA5263 [42]	NA5103 ■ 55x68x8mm, PTFE (50-319391-00) LK5007 ■ [3] 90x173x24mm, PTFE (50-319455-00)		
HBS066 ⊕ (22-11005B) M12x1.50x146.5mm (x14)	JD5108 ■ (x6) (50-029152-00) JD5107 ■ ■ (x6) (50-029153-00) JD5183 ■ (x3) (31-029124-00)	JM5106 50-029149-00	JH5049 (31-029108-00)	PA5016 (x24) 50-307240-70		NA5103 ■ 55x68x8mm, PTFE (50-319391-00) NA5104 ■ 90x110x12mm, PTFE (50-319389-00)		
HBS066 ⊕ (22-11005B) M12x1.50x146.5mm (x14)	JD5108 ■ (x3) (50-029152-00) JD5107 ■ ■ (x3) (50-029153-00)	JM5106 50-029149-00		PA5016 (x24) 50-307240-70		NA5103 ■ 55x68x8mm, PTFE (50-319391-00) LK5007 ■ [3] 90x173x24mm, PTFE (50-319455-00)		
HBS071 ⊕ (22-11037B) M12x1.75x157mm (x14)	JC929 ■ (x6) (31-024376-10) ⊕ JE555 (x2) (31-021849-10)	JN300 →09/79 JN542 31-024221-30 09/79→	JJ538 (31-026671-00)		NA5263 [42]	NB792 ■ 42x62x12mm, FPM (50-306553-50) NB431 ■ 90x110x12mm, FPM (50-306091-50)	NJ066 [2] ■ NA5263 [42]	
HBS071 ⊕ (22-11037B) M12x1.75x157mm (x14)	JC929 ■ (x6) (31-024376-10) ⊕ JE555 (x2) (31-021849-10)	JN542 31-024221-30	JJ538 (31-026671-00)		NA5263 [42]	NB792 ■ 42x62x12mm, FPM (50-306553-50) NB431 ■ 90x110x12mm, FPM (50-306091-50)	NJ066 [2] ■ NA5263 [42]	
HBS071 ⊕ (22-11037B) M12x1.75x157mm (x14)	JC929 ■ (x6) (31-024376-10) ⊕ JE555 (x2) (31-021849-10)	JN542 31-024221-30	JJ538 (31-026671-00)		NA5263 [42]	NB792 ■ 42x62x12mm, FPM (50-306553-50) NB431 ■ 90x110x12mm, FPM (50-306091-50)	NJ066 [2] NA5263 [42]	



KW/PS



7 735 i, iL (E32)		09/86 → 09/92		140		BL690 (Fibre)	DL691
7 745 i (E23)		05/83 → 08/86				30-024647-20	21-24647-25/0
M 30 B 35	3430	6	92.00	Motronic, CIH	162/220		
M 30 B 35	3453	6	92.00	Motronic, CIH	185/252		
7 735 i, iL (E38)		01/96 → 11/01		141		AC5640 (MLS), 1.74mm	CC5350
M 62 B	3498	8	84.00	V8	173/235	30-029389-00	21-29383-20/0
M 62 B 35	3498	8	84.00	Injection, DOHC, V8	173/235	AC5650 (MLS), 1.74mm	
						30-029390-00	
7 740 i, iL (E38)		10/94 → 11/01		142		BX280 (Fibre)	
7 740 i, iL V8 (E32)		04/92 → 09/94				30-027241-00	
M 60 B 40	3982	8	89.00	Injection, DOHC, V8	210/286	BX300 (Fibre) [249]	
						30-027333-00	
						BX270 (Fibre)	
						30-027240-00	
						BX290 (Fibre) [249]	
						30-027332-00	
7 740 i, iL (E38)		01/96 → 11/01		143		AC5380 (Fibre)	CC5350
M 62 B 44 TU	4398	8	92.00	Injection, DOHC, V8	210/286	30-027787-10	21-29383-20/0
M62448S2	4398	8	92.00		210/286	→09/97	09/98 →
M 62 B 44	4398	8	92.00	V8	210/255/286/347	AC5370 (Fibre)	
						30-027785-10	
						→09/97	
						AC5360 (MLS)	
						30-029070-00	
						09/97 →	
						AC5350 (MLS)	
						30-029069-00	
						09/97 →	
7 740 d (E38) Diesel		05/99 → 11/01		144		AE5360 (MLS), 1.52mm, 2 Holes	
M 67 D 39	3901	8	84.00	V8	180/245	(30-029198-00)	
						AE5370 (MLS), 1.62mm, 3 Holes	
						(30-029199-00)	
						AE5340 (MLS), 1.52mm, 2 Holes	
						(30-029196-00)	
						AE5350 (MLS), 1.62mm, 3 Holes	
						(30-029197-00)	
7 740 d (E65, E66) Diesel		10/02 →		145		AE5360 (MLS), 1.52mm, 2 Holes	
N 67 398 D 1	3901	8	84.00	Direct Injection, DOHC, V8	190/258	(30-029198-00)	
						AE5370 (MLS), 1.62mm, 3 Holes	
						(30-029199-00)	
						AE5340 (MLS), 1.52mm, 2 Holes	
						(30-029196-00)	
						AE5350 (MLS), 1.62mm, 3 Holes	
						(30-029197-00)	











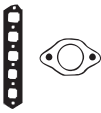

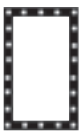

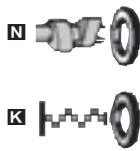

















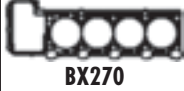

























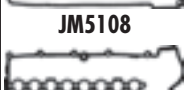









HBS071 (22-11037B) M12x1.75x157mm (x14)	JD315 (x6) (31-025685-20)	JN542 31-024221-30	JJ538 (31-026671-00)		NB792 42x62x12mm, FPM (50-306553-50) NB431 90x110x12mm, FPM (50-306091-50)	NJ066 [2] NA5263 [42]	 AC5370, AC5350 AC5380, AC5360 AC5640 AC5650 AE5340 AE5350 AE5360, AE5370
HBS067 (22-11007B) M10x1.50x110mm (x14)		JM5109 50-027249-00 →09/98 JM5107 (x2) 50-027251-00 →09/98 JM5108 50-027250-00 →09/98 HM5067 24-29384-00/0 09/98 → HM5066 24-29383-00/0 09/98 →	JH5115 (31-027255-10) JH5116 (50-028471-00)	HR791 (x2) 24-30614-76/0	NF637 48x65x10mm, FPM (50-306222-50) NA5132 100x125x13mm, FPM (50-306622-00)	NA5263 [42]	 AC5640 AC5650 AE5340 AE5350 AE5360, AE5370
HBS067 (22-11007B) M10x1.50x110mm (x14)		JM5109 50-027249-00 JM5107 (x2) 50-027251-00 JM5108 50-027250-00	JH5115 (31-027255-10) JH5116 (50-028471-00)	HR791 (x2) 24-30614-76/0	NF637 48x65x10mm, FPM (50-306222-50) NA5132 100x125x13mm, FPM (50-306622-00)	NA5263 [42]	 BL690 BX270 BX280 BX300 JD315 JD5146 JM5108 JN542 JJ538
HBS067 (22-11007B) M10x1.50x110mm (x14)	JD5146 (x3) 31-027247-10	JM5109 50-027249-00 →09/98 JM5107 (x2) 50-027251-00 →09/98 JM5108 50-027250-00 →09/98 HM5067 24-29384-00/0 09/98 → HM5066 24-29383-00/0 09/98 →	JH5115 (31-027255-10) JH5116 (50-028471-00)	HR791 (x2) 24-30614-76/0	NF637 48x65x10mm, FPM (50-306222-50) NA5132 100x125x13mm, FPM (50-306622-00)	NA5263 [42]	 JM5108 JN542 JJ538
			JH5116 (50-028471-00)	HR5045 (x2) 24-30724-07/0	NF637 48x65x10mm, FPM (50-306222-50) NA5132 100x125x13mm, FPM (50-306622-00)		
				HR5045 (x2) 24-30724-07/0	NF637 48x65x10mm, FPM (50-306222-50) NA5132 100x125x13mm, FPM (50-306622-00)		



KW/PS



7 745 i,Li (E65, E66)		11/01 →		146		AC5360 (MLS) ☒		CC5350 ■ ▲	
M 62 B 44 A	4398	8	92.00	Injection, DOHC, V8	235-245/320-333	30-029070-00		21-29383-20/0	
N 62 B 44	4398	8	92.00	Injection, V8	240/326	AC5350 (MLS) ☒ 30-029069-00			
7 750 i,iL V12 (E32)		09/87 → 09/94		147					
M 70 B 50	4988	12	84.00	Injection, V12	220/300				
7 750 i,iL (E38)		12/94 → 11/01		148					
M 73 B 54	5379	12	85.00	SOHC, V12	240/326				
8 Coupe 840 i (E31)		02/93 → 02/96		149		BX280 (Fibre) ☒			
M 60 B 40	3982	8	89.00	Injection, DOHC, V8	210/286	30-027241-00			
						BX300 (Fibre) ☒ [249] 30-027333-00			
						BX270 (Fibre) ☒ 30-027240-00			
						BX290 (Fibre) ☒ [249] 30-027332-00			
8 Coupe 840 Ci (E31)		01/96 → 12/99		150		AC5380 (Fibre) ☒		CC5350 ■ ▲	
M 62 B 44 TU	4398	8	92.00	Injection, DOHC, V8	210/286	30-027787-10		21-29383-20/0	
M 62 B 44	4398	8	92.00	V8	210/255/286/347	→09/97 AC5370 (Fibre) ☒ 30-027785-10 →09/97		09/98 →	
						AC5360 (MLS) ☒ 30-029070-00 09/97 →			
						AC5350 (MLS) ☒ 30-029069-00 09/97 →			
8 850 i,Ci (E31)		04/90 → 10/94		151					
M 70 B 50	4988	12	84.00	Injection, V12	220/300				
8 850 Ci (E31)		09/94 → 12/99		152					
M 73 B 54	5379	12	85.00	SOHC, V12	240/326				
X3 2.0L i (E83)		07/05 →		153		AC5440 (MLS), 0.4mm		CC5440	
N 46 B 20	1995	4	84.00	DOHC	95-110/129-150	30-029315-00		21-29315-20/0	
N 46 B 20 A	1995	4	84.00	Injection, DOHC	110/150	AC5470 (MLS), 0.7mm 30-030333-00			
X3 2.0L d (E83) Diesel		10/04 →		154		AC5410 (MLS), 1.45mm, 1 Hole		CC5410 ■ ▲	
M 47 N 204 D4	1995	4	84.00	DOHC	85-120/116-163	30-029236-00		21-29236-20/0	EC5410 22-29236-00/0
						AC5420 (MLS), 1.55mm, 2 Holes 30-029237-00			
						AC5430 (MLS), 1.65mm, 3 Holes 30-029238-00			

								
HBS067  (22-11007B) M10x1.50x110mm (x14)	JD5146  (x3) 31-027247-10	HM5067   24-29384-00/0 HM5066   24-29383-00/0		HR791  (x2) 24-30614-76/0	NF637  48x65x10mm, FPM (50-306222-50) NA5132  100x125x13mm, FPM (50-306622-00)			 AC5350, AC5370  AC5360, AC5380  AC5410, AC5420, AC5430
			JH5111 (31-025993-10) JH5056  (31-025992-00)	HR662  (x2)	NA5267  55x72x10mm, FPM (50-306465-50) NA5132  100x125x13mm, FPM (50-306622-00)			 AC5440  BX270  BX280  BX300
HBS067  (22-11007B) M10x1.50x110mm (x14)		JM5109  50-027249-00 JM5107 (x2) 50-027251-00 JM5108  50-027250-00	JH5115 (31-027255-10) JH5116  (50-028471-00)	HR791  (x2) 24-30614-76/0	NF637  48x65x10mm, FPM (50-306222-50) NA5132  100x125x13mm, FPM (50-306622-00)	NA5263 [42]		 JD5146  JD5183  JD5428  JE5050
HBS067  (22-11007B) M10x1.50x110mm (x14)	JD5146  (x3) 31-027247-10	JM5109  50-027249-00 →09/98 JM5107 (x2) 50-027251-00 →09/98 JM5108  50-027250-00 →09/98 HM5067   24-29384-00/0 09/98 → HM5066   24-29383-00/0 09/98 →	JH5115 (31-027255-10) JH5116  (50-028471-00)	HR791  (x2) 24-30614-76/0	NF637  48x65x10mm, FPM (50-306222-50) NA5132  100x125x13mm, FPM (50-306622-00)	NA5263 [42]		 JM5108  JM5167  JH5070
			JH5111 (31-025993-10) JH5056  (31-025992-00)	HR602  (x2) 24-30670-61/0	NA5267  55x72x10mm, FPM (50-306465-50) NA5132  100x125x13mm, FPM (50-306622-00)			
			JH5111 (31-025993-10)	HR662  (x2)	NA5267  55x72x10mm, FPM (50-306465-50) NA5132  100x125x13mm, FPM (50-306622-00)			
HBS467 (22-11040B) M8x1.25x95mm (x3) M8x1.25x125mm (x3) M10x1.50x170mm (x6)	HA5024   24-29984-00/0 JD5428  (31-029625-00)  JE5050 (31-029702-00) 1.30mm	HM5160  24-29591-00/0				NA5263 [42]		
HBS121  (22-11006B) M12x1.50x146.5mm (x10)	JD5183  (x2) (31-029124-00)	JM5167 50-029672-00	JH5070 (31-029678-00)	HR5045  24-30724-07/0	NA5103  55x68x8mm, PTFE (50-319391-00) LK5007  [3] 90x173x24mm, PTFE (50-319455-00)	JR5022 [45]		



KW/PS



X3 2.5L si (E83)		09/06 →		155		AG9540 (MLS), 1.2mm 30-030334-00 AG9550 (MLS), 1.5mm 30-030337-00		CG9540 21-30334-00/0		EG9540	
N 52 B 25 A	2497	6	82.00		130- 160/ 177- 218						
X3 2.5L i (E83)		01/04 →		156		AC5900 (MLS), 0.70mm 30-029100-00		CC5901■ 21-29100-21/0		EW802 22-27806-01/0	
M 54 B 25	2494	6	84.00		125/ 141/ 170P/ 192S						
M 54 256 S5	2494	6	84.00	Injection, DOHC	141/192						
X3 3.0L si (E83)		09/06 →		157		AG9290 (MLS), 1,2mm 30-030284-00		CG9540 21-30334-00/0		EG9540	
N 52 B 30 A	2996	6	85.00	DOHC	190- 195/ 258- 265						
X3 3.0L i (E83)		01/04 →		158		AC5900 (MLS), 0.70mm 30-029100-00		CC5901■ 21-29100-21/0		EW802 22-27806-01/0	
M 54 306 S3	2979	6	84.00	Injection, DOHC	163- 170/ 222- 231						
M 54 B 30	2979	6	84.00	Injection, DOHC	170/231						
X3 3.0L d (E83) Diesel		01/04 →		159				CG9000▲ 21-29111-00/0		EG9000	
M57N2306D2	2993	6	84.00	Direct Injection, DOHC	160/218						
X3 3.0L d (E83) Diesel		01/04 →		160		AG9000 (MLS), 1.45mm, 1 Hole 30-029111-00 AG9010 (MLS), 1.55mm, 2 Holes 30-029112-00 AG9020 (MLS), 1.65mm, 3 Holes 30-029113-00		CG9000▲ 21-29111-00/0		EG9000	
M 54 N 306 D2	2993	6	84.00	Direct Injection, DOHC	150/204						
X5 3.0L si (E70)		02/07 →		161		AG9290 (MLS), 1,2mm 30-030284-00		CG9540 21-30334-00/0		EG9540	
N 52 B 30 A	2996	6	85.00	DOHC	190- 195/ 258- 265						
N 52 B 30	2996	6	85.00	DOHC	190- 200/ 258- 272						
X5 3.0L i (E53)		05/00 →		162		AC5900 (MLS), 0.70mm 30-029100-00 AF5190 (MLS), 1.00mm 30-030053-00		CC5901■ 21-29100-21/0 09/02 →		EW802 22-27806-01/0	
M 54 306 S3	2979	6	84.00	Injection, DOHC	163- 170/ 222- 231						
M 54 B 30	2979	6	84.00	Injection, DOHC	170/231						
X5 3.0L d (E70) Diesel		02/07 →		163				CG9000▲ 21-29111-00/0		EG9000	
M 57 306 D3	2993	6	84.00	Direct Injection	170/231						
X5 3.0L d (E53) Diesel		05/01 →		164		BZ660 (MLS), 1.45mm, 1 Hole 30-028559-00 BZ670 (MLS), 1.55mm, 2 Holes 30-028560-00 BZ680 (MLS), 1.65mm, 3 Holes 30-028561-00 AB5980 (MLS), 1.80mm 30-029183-00		DZ660▲■ 21-29149-20/0		EZ660 22-29108-00/0	
M 57 306 D1	2926	6	84.00	DOHC	135- 142/ 184- 193						

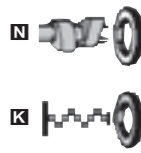
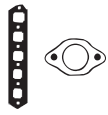

AB5980



AC5900



AF5190



BZ660, BZ670,
BZ680



HA5023



JD5107



JD5108



JD5183



JM5106

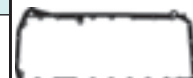

JH5049



JJ611







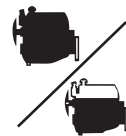



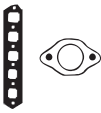

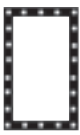

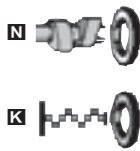

























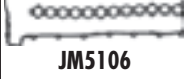













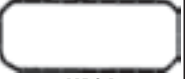





















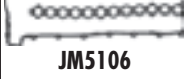













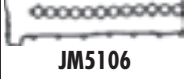













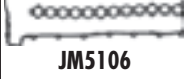













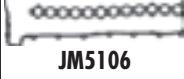





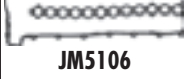

HBS468 (22-11041B) M9x1.25x95mm (x1) M9x1.25x125mm (x3) M10x1.50x125mm (x10)	JD5864 ■ 50-030336-00 JD5909 ■ 31-030374-00	HM5278 ■ 24-30168-00/0	JH5103 (31-030196-00)			
HBS413 ⊕ (22-11039B) M10x1.50x110mm (x14)	HA5023 ■ ■ 24-29075-00/0 JD5916 ■ [274] (31-029088-00)	HM5069 ■ 24-29076-01/0	JJ611 (50-027806-10)	HR280 ■ (x2) 24-30614-75/0	NA5105 ■ 48x65x10mm, PTFE (50-319388-00) NA5104 ■ 90x110x12mm, PTFE (50-319389-00)	
HBS468 (22-11041B) M9x1.25x95mm (x1) M9x1.25x125mm (x3) M10x1.50x125mm (x10)	JD5864 ■ 50-030336-00 JD5909 ■ (x6) 31-030374-00		JH5103 (31-030196-00)			
HBS413 ⊕ (22-11039B) M10x1.50x110mm (x14)	HA5023 ■ ■ 24-29075-00/0 JD5916 ■ [274] (31-029088-00)	HM5069 ■ 24-29076-01/0	JJ611 (50-027806-10)	HR5062 ■ 24-30614-73/0	NA5105 ■ 48x65x10mm, PTFE (50-319388-00) NA5104 ■ 90x110x12mm, PTFE (50-319389-00)	
HBS066 ⊕ (22-11005B) M12x1.50x146.5mm (x14)	JD5108 ■ (x3) (50-029152-00) JD5107 ■ ■ (x3) (50-029153-00)	JM5106 50-029149-00		PA5016 (x24) 50-307240-70	NA5103 ■ 55x68x8mm, PTFE (50-319391-00) LK5007 ■ [3] 90x173x24mm, PTFE (50-319455-00)	
HBS066 ⊕ (22-11005B) M12x1.50x146.5mm (x14)	JD5108 ■ (x6) (50-029152-00) JD5107 ■ ■ (x6) (50-029153-00)	JM5106 50-029149-00		PA5016 (x24) 50-307240-70	NA5103 ■ 55x68x8mm, PTFE (50-319391-00) LK5007 ■ [3] 90x173x24mm, PTFE (50-319455-00)	
HBS468 (22-11041B) M9x1.25x95mm (x1) M9x1.25x125mm (x3) M10x1.50x125mm (x10)	JD5864 ■ 50-030336-00 JD5909 ■ (x6) 31-030374-00		JH5103 (31-030196-00)			
HBS413 ⊕ (22-11039B) M10x1.50x110mm (x14)	HA5023 ■ ■ 24-29075-00/0 JD5916 ■ [274] (31-029088-00) ⊕ JE5012 (x2) (31-029096-00)	HM5069 ■ 24-29076-01/0 09/02 →	JJ611 (50-027806-10)	HR5062 ■ 24-30614-73/0	NA5105 ■ 48x65x10mm, PTFE (50-319388-00) NA5104 ■ 90x110x12mm, PTFE (50-319389-00)	NA5263 [42]
HBS066 ⊕ (22-11005B) M12x1.50x146.5mm (x14)	JD5108 ■ (x3) (50-029152-00) JD5107 ■ ■ (x3) (50-029153-00)	JM5106 50-029149-00		PA5016 (x24) 50-307240-70	NA5103 ■ 55x68x8mm, PTFE (50-319391-00) LK5007 ■ [3] 90x173x24mm, PTFE (50-319455-00)	
HBS066 ⊕ (22-11005B) M12x1.50x146.5mm (x14)	JD5108 ■ (x6) (50-029152-00) JD5183 ■ (x3) (31-029124-00)	JM5106 50-029149-00	JH5049 (31-029108-00)	PA5016 (x24) 50-307240-70	NA5103 ■ 55x68x8mm, PTFE (50-319391-00) NA5104 ■ 90x110x12mm, PTFE (50-319389-00)	NA5263 [42]



KW/PS



X5 3.0L d (E53) Diesel				12/03 →		165		
M 57 N 306 D4	2993	6	84.00	DOHC	160/218	AG9000 (MLS), 1.45mm, 1 Hole 30-029111-00 AG9010 (MLS), 1.55mm, 2 Holes 30-029112-00 AG9020 (MLS), 1.65mm, 3 Holes 30-029113-00	CG9000▲ 21-29111-00/0	
X5 4.4L i (E53)				05/00 →		166		
M 62 B 44 TU	4398	8	92.00	Injection, DOHC, V8	210/286	AC5360 (MLS) 30-029070-00 AC5350 (MLS) 30-029069-00	CC5350■▲ 21-29383-20/0	
M 62 B 44	4398	8	92.00	V8	210/ 255/ 286/ 347			
M 62 B 44 A	4398	8	92.00	Injection, DOHC, V8	235- 245/ 320- 333			
N 62 B 44	4398	8	92.00	Injection, V8	240/326			
X5 4.6L is (E53)				02/02 →		167		
M 62 B 46/M 67 468 S1	4619	8	93.00	Injection, DOHC, V8	255/347			
X6 35 i (E71)				05/08 →		168		
N 54 B 30 A	2996	6	84.00	Injection, DOHC		AH5120 (MLS)		
Z1 Convertible 2.5L				06/88 →06/91		169		
M 20 B 25	2494	6	84.00	Motronic, CIH	126/171	BL680 (Fibre) 30-025354-30	DL681 21-25354-23/0 01/87 →	EX932 22-23925-03/0
Z3 Convertible 1.8L				10/95 →10/98		170		
M 43 B 18	1796	4	84.00	Injection	85/116	BR830 (Fibre) 30-026068-20	DR831■	
Z3 Convertible 1.9L				07/98 →01/03		171		
M 43 B 19 TU	1895	4	85.00	Injection, SOHC	77-87/ 105- 118	AB5660 (Fibre) 30-028501-00	CB5660■ 21-28501-20/0	EB5660 22-29063-00/0
M 43 194 E1	1895	4	85.00	Injection, SOHC	85-87/ 116- 118			
M 43 B 19	1895	4	85.00	Injection, SOHC	87/118			
Z3 Convertible 1.9L				10/95 →03/99		172		
M 44 B 19	1895	4	85.00		103/140	BZ130 (Fibre) 30-027702-10	DZ130■ 21-27702-21/0	
Z3 Convertible 2.0L				04/99 →01/03		173		
M 52 B	1991	6	80.00	Motronic, DOHC	110/150	AC5310 (MLS) 30-029078-00		EW802 22-27806-01/0
M 52 B 20	1991	6	80.00	DOHC	110/150			

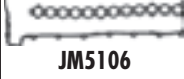









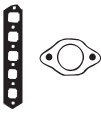

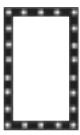

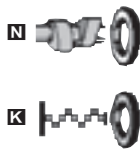









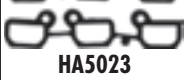







								
HBS066  (22-11005B) M12x1.50x146.5mm (x14)	JD5108  (x6) (50-029152-00) JD5107   (x6) (50-029153-00) JD5183  (31-029124-00)	JM5106 50-029149-00		PA5016 (x24) 50-307240-70	NA5103  55x68x8mm, PTFE (50-319391-00) LK5007  [3] 90x173x24mm, PTFE (50-319455-00)	NA5263 [42]		 AB5660  AC5310  AC5350  AC5360  BL680  BR830  BZ130  HA5023  JD243  JD5107  JD5108  JD5146  JD5183  JD611  JE5019  JF191  JM5097  JM5106
HBS067  (22-11007B) M10x1.50x110mm (x14)	JD5146  (x3) 31-027247-10	JM5097  (50-029384-00) JM5098 (x2) (50-029385-00) JM5096  50-029383-00 HM5067   24-29384-00/0 HM5066   24-29383-00/0	JH5115 (31-027255-10)	HR791  (x2) 24-30614-76/0	NF637  48x65x10mm, FPM (50-306222-50) NA5132  100x125x13mm, FPM (50-306622-00)			 JN297  JP079  JJ104  JJ611  JJ612
HBS067  (22-11007B) M10x1.50x110mm (x14)	JD5146  (x3) 31-027247-10	JM5097  (50-029384-00) JM5098 (x2) (50-029385-00) JM5096  50-029383-00 HM5067   24-29384-00/0 HM5066   24-29383-00/0		HR791  (x2) 24-30614-76/0				 HA5023  JD243  JD5107  JD5108  JD5146  JD5183  JD611  JE5019  JF191  JM5097  JM5106
	JD5864  50-030336-00		JH5103 (31-030196-00)					
HBS041  (22-11003B) M10x1.50x150mm (x14)	JD239  (x1) (31-025324-10) JE5074  (31-025811-00)	JN297 31-023951-20	JJ104 (31-023925-20)	HR662  (x2)	NB799  38x50x7mm, FPM (50-306223-50) NF637  48x65x10mm, FPM (50-306222-50) NB431  90x110x12mm, FPM (50-306091-50)	NA5263 [42]		 JD5146  JD5183  JD611  JE5019  JF191  JM5097  JM5106
HBS069  (22-11004B) M10x1.50x95mm (x10)	JD611  (x2) (31-028409-00) JD243  [274] 31-027845-00 JE5019  (31-026163-00)	JP079 50-028394-00	JJ612 (50-028405-00)	HR646  24-30670-60/0	NA5099  44x60x10mm, PTFE (50-319382-00) NB431  90x110x12mm, FPM (50-306091-50)	NA5263 [42] JR5031 [11] JR5046 [11]		 JD5146  JD5183  JD611  JE5019  JF191  JM5097  JM5106
HBS069  (22-11004B) M10x1.50x95mm (x10)	JD5858  50-029061-00 JD243  [274] 31-027845-00 JE5019  (31-026163-00)	JP079 50-028394-00	JH5050 (50-029063-00)	HR646  24-30670-60/0	NA5099  44x60x10mm, PTFE (50-319382-00) NA5104  90x110x12mm, PTFE (50-319389-00)	NA5263 [42] JR5031 [11] JR5046 [11]		 JD5146  JD5183  JD611  JE5019  JF191  JM5097  JM5106
HBS069  (22-11004B) M10x1.50x95mm (x10)	JD611  (x2) (31-028409-00)	JP032 (50-026541-00) HL733  (24-26539-00/0)		HR817  (x2) 24-30614-78/0	NA5099  44x60x10mm, PTFE (50-319382-00) NB431  90x110x12mm, FPM (50-306091-50)	NA5263 [42]		 JM5097  JM5106
HBS413  (22-11039B) M10x1.50x110mm (x14)	HA5023   24-29075-00/0 JD5916  [274] (31-029088-00) JF191 (x2) (31-026695-10)	HL736  24-27949-00/0	JJ611 (50-027806-10)	HR280  (x2) 24-30614-75/0	NA5105  48x65x10mm, PTFE (50-319388-00) NA5104  90x110x12mm, PTFE (50-319389-00)	KK5520 [53] KK5484 [14] NA5263 [42] JR5044 [11]		 JM5097  JM5106



KW/PS



Z3 Convertible 2.2L		08/00 → 01/03		174		AC5310 (MLS)		EW802	
M 54 226 S1	2171	6	80.00	Injection, DOHC	125/170	30-029078-00		22-27806-01/0	
M 54 B 22	2171	6	80.00	DOHC	125/170				
Z3 Convertible 2.8L		04/97 → 06/00		175		BT690 (Fibre)		DT692	
Z3 Coupe 2.8L		07/97 → 06/00				30-026706-20		21-26706-23/0	
M 52 B 28/ M 52 B 28 TU	2793	6	84.00	Injection, DOHC	142/193	→08/98	→09/98	22-27806-02/0	→08/98
						AC5900 (MLS), 0.70mm	CC5900	22-27806-01/0	EW802
						30-029100-00	21-29100-20/0	22-27806-01/0	
						09/98 →	09/98 →	09/98 →	09/98 →
						AF5190 (MLS), 1.00mm			
						30-030053-00			
						09/98 →			
Z3 Convertible 3.0L		06/00 → 01/03		176		AC5900 (MLS), 0.70mm		CC5901	
Z3 Coupe 3.0L		06/00 → 06/03				30-029100-00		21-29100-21/0	
M 54 306 S3	2979	6	84.00	Injection, DOHC	163- 170/ 222- 231	AF5190 (MLS), 1.00mm	09/02 →	22-27806-01/0	EW802
M 54 B 30	2979	6	84.00	Injection, DOHC	170/231	30-030053-00			
Z4 Convertible 2.0L i (E85)		04/05 →		177		AC5440 (MLS), 0.4mm		CC5440	
N 46 B 20	1995	4	84.00	DOHC	95-110/ 129- 150	30-029315-00		21-29315-20/0	
N 46 B 20 A	1995	4	84.00	Injection, DOHC	110/150	AC5470 (MLS), 0.7mm			
						30-030333-00			
Z4 Convertible 2.2L i (E85)		10/03 →		178		AC5310 (MLS)		EW802	
M 54 226 S1	2171	6	80.00	Injection, DOHC	125/170	30-029078-00		22-27806-01/0	
M 54 B 22	2171	6	80.00	DOHC	125/170				
Z4 2.5L i (E85)		01/06 →		179		AG9540 (MLS), 1.2mm		CG9540	
Z4 2.5L si (E85)		01/06 →				30-030334-00		21-30334-00/0	
N 52 B 25 A	2497	6	82.00		130- 160/ 177- 218	AG9550 (MLS), 1.5mm			EG9540
						30-030337-00			
Z4 Convertible 2.5L i (E85)		02/03 →		180		AC5900 (MLS), 0.70mm		CC5901	
M 54 B 25	2494	6	84.00		125/ 141/ 170P/ 192S	30-029100-00	09/02 →	22-27806-01/0	EW802
M 54 256 S5	2494	6	84.00	Injection, DOHC	141/192	AF5190 (MLS), 1.00mm			
						30-030053-00			

								
HBS068 [135] (22-11003B) M10x1.50x95mm (x14) HBS413 [136] (22-11039B) M10x1.50x110mm (x14)	HA5023 [S] 24-29075-00/0 JD5916 [274] (31-029088-00)  JE5012 (31-029096-00)	HM5069 [S] 24-29076-01/0	JJ611 (50-027806-10)	HR5062 [S] 24-30614-73/0	 NA5105 [F] 48x65x10mm, PTFE (50-319388-00)  NA5104 [R] 90x110x12mm, PTFE (50-319389-00)	NA5263 [42]	 AC5310  AC5440  AC5900  AF5190  BT690  HA5023  JD492  JD497  JD5428  JE5050  JF191  JJ611	
HBS067 [136] (22-11007B) M10x1.50x110mm (x14) HBS068 [135] (22-11003B) M10x1.50x95mm (x14)	JD492 [x2] 50-027797-00 →08/98 HA5023 [S] 24-29075-00/0 09/98 → JD497 [x2] 31-027953-00 →09/98 JD5916 [274] (31-029088-00)  JF191 (x2) (31-026695-10)	HL736 [S] 24-27949-00/0 →08/98	JJ611 (50-027806-10)	HR280 [x2] 24-30614-75/0	 NA5105 [F] 48x65x10mm, PTFE (50-319388-00)  NA5104 [R] 90x110x12mm, PTFE (50-319389-00)	KK5520 [53] KK5484 [14] NA5263 [42] JR5044 [11]		
HBS413 [136] (22-11039B) M10x1.50x110mm (x14)	HA5023 [S] 24-29075-00/0 JD5916 [274] (31-029088-00)  JE5012 (x2) (31-029096-00)	HM5069 [S] 24-29076-01/0 09/02 →	JJ611 (50-027806-10)	HR5062 [S] 24-30614-73/0	 NA5105 [F] 48x65x10mm, PTFE (50-319388-00)  NA5104 [R] 90x110x12mm, PTFE (50-319389-00)	NA5263 [42]		
HBS467 (22-11040B) M8x1.25x95mm (x3) M8x1.25x125mm (x3) M10x1.50x170mm (x6)	HA5024 [S] 24-29984-00/0 JD5428 (31-029625-00)  JE5050 (31-029702-00) 1.30mm	HM5160 [S] 24-29591-00/0						
HBS413 [136] (22-11039B) M10x1.50x110mm (x14)	HA5023 [S] 24-29075-00/0	HM5069 [S] 24-29076-01/0	JJ611 (50-027806-10)	HR5062 [S] 24-30614-73/0	 NA5105 [F] 48x65x10mm, PTFE (50-319388-00)  NA5104 [R] 90x110x12mm, PTFE (50-319389-00)	NA5263 [42]		
HBS468 (22-11041B) M9x1.25x95mm (x1) M9x1.25x125mm (x3) M10x1.50x125mm (x10)	JD5864 [1] 50-030336-00 JD5909 [S] 31-030374-00	HM5278 [S] 24-30168-00/0	JH5103 (31-030196-00)					
HBS413 [136] (22-11039B) M10x1.50x110mm (x14)	HA5023 [S] 24-29075-00/0 JD5916 [274] (31-029088-00)  JE5012 (x2) (31-029096-00)	HM5069 [S] 24-29076-01/0 09/02 →	JJ611 (50-027806-10)	HR5062 [S] 24-30614-73/0	 NA5105 [F] 48x65x10mm, PTFE (50-319388-00)  NA5104 [R] 90x110x12mm, PTFE (50-319389-00)	NA5263 [42]		



KW/PS



Z4 3.0L si (E85) 01/06 →					181	AG9290 (MLS), 1,2mm	CG9540	EG9540
Z4 Coupe 3.0L si 03/06 →						30-030284-00	21-30334-00/0	
N 52 B 30 A	2996	6	85.00	DOHC	190- 195/ 258- 265			
N 52 B 30	2996	6	85.00	DOHC	190- 200/ 258- 272			
Z4 Convertible 3.0L i (E85) 02/03 →					182	AC5900 (MLS), 0.70mm	CC5901■	EW802
M 54 306 S3	2979	6	84.00	Injection, DOHC	163- 170/ 222- 231	30-029100-00 AF5190 (MLS), 1.00mm 30-030053-00	21-29100-21/0 09/02 →	22-27806-01/0
M 54 B 30	2979	6	84.00	Injection, DOHC	170/231			

HBS468 (22-11041B) M9x1.25x95mm (x1) M9x1.25x125mm (x3) M10x1.50x125mm (x10)	JD5864 50-030336-00 JD5909 31-030374-00		JH5103 (31-030196-00)				AC5900 AF5190 HA5023 JJ611
HBS413 (22-11039B) M10x1.50x110mm (x14)	HA5023 24-29075-00/0 JD5916 [274] (31-029088-00) JE5012 (x2) (31-029096-00)	HM5069 24-29076-01/0 09/02 →	JJ611 (50-027806-10)	HR5062 24-30614-73/0	NA5105 48x65x10mm, PTFE (50-319388-00) NA5104 90x110x12mm, PTFE (50-319389-00)	NA5263 [42]	







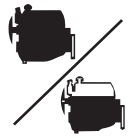

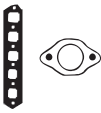

CARBODIES

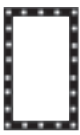

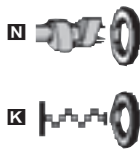
KW/PS

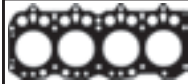

FL2 2.3L D Diesel		09/72 → 09/85		1	AG210 (Fibre) [121]	CG210 [121]	EG212 [12]
Rover 22E	2286	4	90.47	44-45/ 60-61	BM850 (Fibre) (30-027588-00)		
FL2 2.5L D Diesel		01/85 → 12/89		2	BM850 (Fibre) (30-027588-00)	DM850 ■ (21-27588-20/0)	EM850 (22-27589-00/0)
Rover 25V	2494	4	90.47	49-50/ 67-68			
FX4 2.3L D Diesel		09/72 → 12/85		3	AG210 (Fibre) [121]	CG210 [121]	EG212 [12]
Rover 22E	2286	4	90.47	44-45/ 60-61	BM850 (Fibre) (30-027588-00)		
FX4 2.5L D Diesel		09/85 → 12/89		4	BM850 (Fibre) (30-027588-00)	DM850 ■ (21-27588-20/0)	EM850 (22-27589-00/0)
Rover 25V	2494	4	90.47	49-50/ 67-68			

								      	 <p>AG210</p>  <p>BM850</p>  <p>JC882</p>  <p>JM350</p>  <p>JH409</p>
	JC882	JM350	JH409 (31-027589-00)	HR635 (x2)	<input checked="" type="checkbox"/> NB849 48.7x63.5x8mm, FPM (50-319467-00) <input checked="" type="checkbox"/> NB848 100x120x11mm, PTFE				
	JC882	JM350	JH409 (31-027589-00)	HR635 (x2)	<input checked="" type="checkbox"/> NB849 48.7x63.5x8mm, FPM (50-319467-00) <input checked="" type="checkbox"/> NB848 100x120x11mm, PTFE				
	JC882	JM350	JH409 (31-027589-00)	HR635 (x2)	<input checked="" type="checkbox"/> NB849 48.7x63.5x8mm, FPM (50-319467-00) <input checked="" type="checkbox"/> NB848 100x120x11mm, PTFE				
	JC882	JM350	JH409 (31-027589-00)	HR635 (x2)	<input checked="" type="checkbox"/> NB849 48.7x63.5x8mm, FPM (50-319467-00) <input checked="" type="checkbox"/> NB848 100x120x11mm, PTFE				

CHEVROLET



KW/PS



Astra 2.2L		08/00 → 08/04				1	AG9580 (MLS) (30-030344-00)	CG9580 (21-30344-00/0)	
Z 22 SE	2198	4	86.00	DOHC	108/147				
Evanda 2.0L		03/05 →				2	BY250 (Fibre) (30-027987-10)	DY250 (21-27987-20/0)	EC100 (22-27206-01/0)
X20SED	1998	4	86.00	Injection, DOHC	96/131				
Kalos 1.4L 16V		03/05 →				3	AG8000 (MLS)		
F14D3	1399	4	77.90	Injection, DOHC	69/94				
Lacetti 1.4L 16V		03/05 →				4	AG8000 (MLS)		
F14D3	1399	4	77.90	Injection, DOHC	70/95				
Lacetti 1.6L		03/05 →				5	AG8000 (MLS)		
F16D3	1598	4	79.00	DOHC	80/109				
Lacetti 1.8L		03/05 →				6			EC100 (22-27206-01/0)
T18SED	1799	4	81.60	Injection, DOHC	90/122				
Matiz 0.8L		03/05 →				7	AD5690 (Fibre) (30-029654-00) →12/06	CD5691 →12/06	ED5690 →12/06 FD5690 →12/06
F8CV	796	3	68.50	Injection, SOHC	38/52				
Nubira 1.6L		03/05 →				8	AG8000 (MLS)		
F16D3	1598	4	79.00	DOHC	80/109				
Nubira 1.8L		03/05 →				9			EC100 (22-27206-01/0)
T18SED	1799	4	81.60	Injection, DOHC	90/122				
Optra 1.6L		08/03 →				10	AG8000 (MLS)		
F16D3	1598	4	79.00	DOHC	80/109				

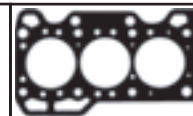
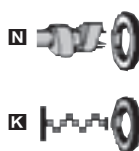
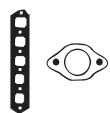

AD5690



BY250



JD451



JD5794



JP016



JJ616



JJ617

HBS416 ⊕ (22-29025B) M11x1.50x163mm (x10)	KG5337 ■ (50-350435-00) (MVQ) JD5868 ■ (31-030346-00)				NA5108 ■ 42x55x7mm, FPM (50-319392-00) NB806 ■ 90x104x11mm, FPM (50-306552-00)	
HBS054 ⊕ (22-29013B) M11x1.25x105mm (x10)	JD451 ■ (31-027699-00)	JP016 (50-027683-00)	JJ616 ■ (31-028386-00) JJ617 ■ (31-028385-00)	HR791 ■ 24-30614-76/0	NC006 (x2) 35x48x7mm, MVQ (50-319161-00) NB700 ■ 31x50x8mm, FPM (50-306551-50) NB806 ■ 90x104x11mm, FPM (50-306552-00)	
	JD5739 ■ (Fibre) JD5794 ■ (31-029643-00) (MLS)	JM5303	HR397 [57] 34-000410-00	NA5164 (x16) (50-307253-70)	NA5190 42x56x7mm, FPM (50-307352-70) NF812 ■ 30x42x8mm, ACM (50-319440-00) NB698 ■ 80x98x10mm, FPM (50-319273-00)	
	JD5739 ■ (Fibre) JD5794 ■ (31-029643-00) (MLS)	JM5303	HR397 [57] 34-000410-00	NA5164 (x16) (50-307253-70)	NA5190 42x56x7mm, FPM (50-307352-70) NF812 ■ 30x42x8mm, ACM (50-319440-00) NB698 ■ 80x98x10mm, FPM (50-319273-00)	
HBS285 ⊕ (22-77001B) M10x1.25x166mm (x10)	JD5739 ■ (Fibre) JD5794 ■ (31-029643-00) (MLS)	JM5303	HR397 [57] 34-000410-00	NA5164 (x16) (50-307253-70)	NA5190 42x56x7mm, FPM (50-307352-70) NF812 ■ 30x42x8mm, ACM (50-319440-00) NB698 ■ 80x98x10mm, FPM (50-319273-00)	
HBS054 ⊕ (22-29013B) M11x1.25x105mm (x10)	JD451 ■ (31-027699-00)		JJ616 ■ (31-028386-00) JJ617 ■ (31-028385-00)	HR791 ■ 24-30614-76/0	NC006 (x2) 35x48x7mm, MVQ (50-319161-00) NB700 ■ 31x50x8mm, FPM (50-306551-50) NB806 ■ 90x104x11mm, FPM (50-306552-00)	
HBS377 ⊕ (22-77004B) M10x1.25x97mm (x10)	JD5740 ■ (50-029661-00) JE5034 ■ (31-029655-00)	JM5263 (50-029656-00) (Rubber)		HR5075 ■ (24-31945-40/0)	NJ377 ■ 32x47x6mm, ACM NJ337 ■ 60x80x8mm, NBR	
HBS285 ⊕ (22-77001B) M10x1.25x166mm (x10)	JD5739 ■ (Fibre) JD5794 ■ (31-029643-00) (MLS)	JM5303	HR397 [57] 34-000410-00	NA5164 (x16) (50-307253-70)	NA5190 42x56x7mm, FPM (50-307352-70) NF812 ■ 30x42x8mm, ACM (50-319440-00) NB698 ■ 80x98x10mm, FPM (50-319273-00)	
HBS054 ⊕ (22-29013B) M11x1.25x105mm (x10)	JD451 ■ (31-027699-00)		JJ616 ■ (31-028386-00) JJ617 ■ (31-028385-00)	HR791 ■ 24-30614-76/0	NC006 (x2) 35x48x7mm, MVQ (50-319161-00) NB700 ■ 31x50x8mm, FPM (50-306551-50) NB806 ■ 90x104x11mm, FPM (50-306552-00)	
HBS285 ⊕ (22-77001B) M10x1.25x166mm (x10)	JD5739 ■ (Fibre) JD5794 ■ (31-029643-00) (MLS)	JM5303	HR397 [57] 34-000410-00	NA5164 (x16) (50-307253-70)	NA5190 42x56x7mm, FPM (50-307352-70) NF812 ■ 30x42x8mm, ACM (50-319440-00) NB698 ■ 80x98x10mm, FPM (50-319273-00)	











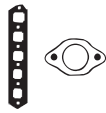

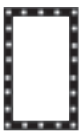







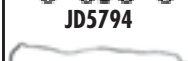

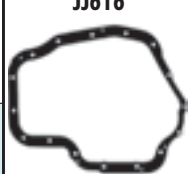

































CHEVROLET



KW/PS



Rezzo 1.6L					03/05 →	11	AB5230 (Fibre) (30-029642-00)	CB5230 (21-29642-20/0)
A16DMS	1598	4	79.00	Injection, DOHC	77/105			
A16DMS	1598	4	79.00	Injection, DOHC	79/107			
Rezzo 2.0L					03/05 →	12	BY250 (Fibre) (30-027987-10)	EC100 (22-27206-01/0)
T20SED	1998	4	86.00	Injection, DOHC	89/121			
Spark 0.8L					09/00 →	13	AD5690 (Fibre) (30-029654-00) →12/06	CD5691 →12/06 ED5690 →12/06 FD5690 →12/06
F8CV	796	3	68.50	Injection, SOHC	37/50			
F8CV	796	3	68.50	Injection, SOHC	38/52			
Vectra 2.2L					04/02 →04/04	14	AG9580 (MLS) (30-030344-00)	CG9580 (21-30344-00/0)
Z 22 SE	2198	4	86.00	DOHC	108/147			
Vectra 2.2L					05/04 →07/06	15	AG9590 (MLS) (30-030345-00)	CG9590 (21-30345-00/0)
Z 22 YH	2198	4	86.00	DOHC	114/155			
Vivant 1.6L					08/01 →	16	AB5230 (Fibre) (30-029642-00)	CB5230 (21-29642-20/0)
A16DMS	1598	4	79.00	Injection, DOHC	77/105			
A16DMS	1598	4	79.00	Injection, DOHC	78/106			
Zafira 2.2L					07/05 →	17	AG9590 (MLS) (30-030345-00)	CG9590 (21-30345-00/0)
Z 22 YH	2198	4	86.00	DOHC	110/150			

																
HBS285  (22-77001B) M10x1.25x166mm (x10)	JD5739  (Fibre) JD5794  (31-029643-00) (MLS)	HM5227 	HR397 [57] 34-000410-00	NA5164 (x16) (50-307253-70)	NA5190  42x56x7mm, FPM (50-307352-70) NF812  30x42x8mm, ACM (50-319440-00) NB698  80x98x10mm, FPM (50-319273-00)											
HBS054  (22-29013B) M11x1.25x105mm (x10)	JD451  (31-027699-00)	JP016 (50-027683-00)	JJ616  (31-028386-00) JJ617  (31-028385-00)	HR791  24-30614-76/0	NC006 (x2) 35x48x7mm, MVQ (50-319161-00) NB700  31x50x8mm, FPM (50-306551-50) NB806  90x104x11mm, FPM (50-306552-00)											
HBS377  (22-77004B) M10x1.25x97mm (x10)	JD5740  (50-029661-00) JE5034  (31-029655-00)	JM5263 (50-029656-00) (Rubber)		HR5075  (24-31945-40/0)	NJ377  32x47x6mm, ACM NJ337  60x80x8mm, NBR											
HBS416  (22-29025B) M11x1.50x163mm (x10)	KG5337  (50-350435-00) (MVQ) JD5868  (31-030346-00)				NA5108  42x55x7mm, FPM (50-319392-00) NB806  90x104x11mm, FPM (50-306552-00)											
HBS416  (22-29025B) M11x1.50x163mm (x10)	JD5869  (x3) (31-030358-00) JD5870  (31-030359-00) JD5868  (31-030346-00)		HR397 [57] 34-000410-00		NA5108  42x55x7mm, FPM (50-319392-00) NB806  90x104x11mm, FPM (50-306552-00)											
HBS285  (22-77001B) M10x1.25x166mm (x10)	JD5739  (Fibre) JD5794  (31-029643-00) (MLS)	HM5227 	HR397 [57] 34-000410-00	NA5164 (x16) (50-307253-70)	NA5190  42x56x7mm, FPM (50-307352-70) NF812  30x42x8mm, ACM (50-319440-00) NB698  80x98x10mm, FPM (50-319273-00)											
HBS416  (22-29025B) M11x1.50x163mm (x10)	JD5869  (x3) (31-030358-00) JD5870  (31-030359-00) JD5868  (31-030346-00)		HR397 [57] 34-000410-00		NA5108  42x55x7mm, FPM (50-319392-00) NB806  90x104x11mm, FPM (50-306552-00)											



CC



9



CC



9

09B	Diesel	2500	4		34
148	Petrol	2429	4	87.50	2
148	Petrol	2429	4	87.50	24
148	Petrol	2429	4	87.50	26
148	Petrol	2429	4	87.50	3
300	Petrol	2972	6		36
420T	Petrol	1996	4	87.50	12
420X	Petrol	1996	4	87.50	25
425 CLIEE	Diesel	2499	4	92.00	35
425 CLIEE	Diesel	2499	4	92.00	5
425 CLIRS/X	Diesel	2499	4	92.00	33
625H	Petrol	2499	6	83.50	28
6G72	Petrol	2972	6	91.10	21
6G72	Petrol	2972	6	91.10	36
6G72	Petrol	2972	6	91.10	8
B00	Petrol	2429	4	87.50	31
C00	Petrol	1995	4		25
C00	Petrol	1995	4		29
EBD	Petrol	1796	4	83.00	10
ECB	Petrol	1996	4	87.50	25
ECB (420H)	Petrol	1996	4	87.50	11
ECC	Petrol	1996	4	87.50	12
ECC	Petrol	1996	4	87.50	15
ECC	Petrol	1996	4	87.50	16
ECC	Petrol	1996	4	87.50	22
ECH	Petrol	1996	4	87.50	13
EDJ	Diesel	2148	4	88.00	17
EDZ	Petrol	2429	4	87.50	19
EDZ	Petrol	2429	4	87.50	20
EDZ	Petrol	2429	4	87.50	23
EDZ	Petrol	2429	4	87.50	27
EDZ	Petrol	2429	4	87.50	30
EEB	Petrol	2497	6	83.50	28
EFA	Petrol	2972	6	91.10	8
EGA	Petrol	3301	6	93.00	37
EGX	Petrol	3199	6	89.90	4
EJD	Petrol	1598	4	77.00	14
EJD	Petrol	1598	4	77.00	9
ENC	Diesel	2499	4	92.00	32
ENJ	Diesel	2499	4	92.00	32
H00	Petrol	2497	6	83.50	28
M00 (HR 425 CL)	Diesel	2499	4	92.00	34
M00 (HR 425 CL)	Diesel	2499	4	92.00	6
M664	Diesel	2987	6	83.00	1
R00 (201)	Petrol	3301	6	93.00	37
R00 (201)	Petrol	3301	6	93.00	7

CHRYSLER



KW/PS

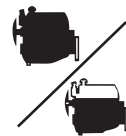

300 C 3.0L CRD Diesel 09/05 →					1			
300 C Touring 3.0L CRD Diesel 09/05 →								
M664	2987	6	83.00	DOHC, V6	160/218			
Breeze 2.5L L 01/95 → 12/01					2	AC5560 (MLS) (30-029574-00)	CC5560	EC5560
148	2429	4	87.50	DOHC				
Cirrus 2.5L L 01/95 → 12/01					3	AC5560 (MLS) (30-029574-00)	CC5560	EC5560
148	2429	4	87.50	DOHC				
Crossfire Coupe 3.2L 07/03 →					4	AE5750 (MLS) 30-029988-00 AE5760 (MLS) 30-029989-00		
EGX	3199	6	89.90	Injection, V6	160/218			
Grand Voyager 2.5L TD Diesel 01/95 →					5	AY400 (MLS), 1.42mm, 0 Notches (30-028472-00) AY410 (MLS), 1.52mm, 2 Notches (30-028473-00) AY420 (MLS), 1.62mm, 1 Notch (30-028474-00)	DK573 ▲ [105] (21-28472-20/0)	GK573 ▲ [8] (20-28472-00/0)
425 CLJEE	2499	4	92.00	OHV, Turbo				
Grand Voyager 2.5L TD Diesel 01/92 → 12/94					6	BK570 (Fibre), 1.42mm, 0 Notches (x4) (30-025008-20) BP260 (Fibre), 1.52mm, 2 Notches (x4) (30-025013-20) BK580 (Fibre), 1.62mm, 1 Notch (x4) (30-025007-20)	DK570 ▲ [7] (21-25850-21/0)	GK572 ▲ [8] (20-25850-01/0)
MOO (HR 425 CL)	2499	4	92.00		85-87/ 116- 118			
Grand Voyager 3.3L V6 01/90 → 12/00					7	AC5590 (Fibre) (30-029535-00) AC5580 (Fibre) (30-029534-00)	CC5580 (21-29534-20/0)	
R00 (201)	3301	6	93.00	OHV, V6	112/152			
Le Baron 3.0L i V6 01/90 → 12/94					8	BR600 (Graphite) (x2) (30-028200-00)	DR600 (21-28200-20/0)	GR600
Le Baron Convertible 3.0L i V6 01/90 → 12/96								
EFA	2972	6	91.10	OHV, V6	100- 112/ 136- 152			
6672	2972	6	91.10	SOHC, V6	106/144			
Neon Mk II 1.6L 11/01 →					9	AC5920 (MLS), 0.65mm (30-029488-00)	CC5920 (21-29489-20/0)	EC5921 (22-29488-01/0) →07/04
EJD	1598	4	77.00	SOHC	85/116			
Neon 1.8L 16V 09/97 → 08/99					10	AC5550 (MLS) (30-029533-00)	CC5550 (21-29533-20/0)	
EBD	1796	4	83.00		85/116			
Neon 2.0L 16V 05/94 → 08/99					11	AC5550 (MLS) (30-029533-00)	CC5550 (21-29533-20/0)	
ECB (420H)	1996	4	87.50	SOHC	98/133			

HBS474 (22-26025B) M12x1.75x205mm (x16)					NA5131 45x67x8mm, PTFE (50-319436-00) NA5168 93x114x11.5mm, PTFE (50-319437-00)		 AC5550 AC5560 AC5580 AC5920 AE5750
HBS279 (22-29018B) M11x1.50x154mm (x6) M11x1.50x109mm (x4)							 AC5580 AC5920 AE5750
HBS279 (22-29018B) M11x1.50x154mm (x6) M11x1.50x109mm (x4)							 AE5750
				HR5055 24-30704-45/0	NA5131 45x67x8mm, PTFE (50-319436-00) NA5168 93x114x11.5mm, PTFE (50-319437-00)		 AY400, AY410, AY420 BK570, BP260, BK580
HBS108 (22-56003B) M14x2.0x137mm (x10) M12x1.75x115mm (x4) M12x1.75x79.5mm (x4)	JD5144 (31-028425-00)	JP068 [9] (31-029626-00)					 AY400, AY410, AY420 BK570, BP260, BK580
HBS108 (22-56003B) M14x2.0x137mm (x10) M12x1.75x115mm (x4) M12x1.75x79.5mm (x4)	JC928 (x4) (31-025852-10) JD025 (x4) (31-025849-10)						 BR600 JC928 JD025
							 JD5144
HBS402 (22-76018B)							 JM5119 JP068
	JD5826 (x4) (50-030260-00) (Rubber) JD5827 (31-030261-00) (Rubber/Metal)	JM5119 (50-029489-00)	JH5051 (31-029592-00)		NA5139 32x45x6mm, FPM (50-319449-00) NA5140 91x111x10mm, FPM (50-319450-00)		 JH5051
HBS391 (22-29022B) 01/94→		HM5225	JH5060 (31-029627-00)	HR5061 (24-31944-50/0)	NC006 35x48x7mm, MVQ (50-319161-00) NA5139 32x45x6mm, FPM (50-319449-00) NA5140 91x111x10mm, FPM (50-319450-00)		 JH5060
HBS391 (22-29022B) 01/94→		HM5225	JH5060 (31-029627-00)	HR5061 (24-31944-50/0)	NC006 (x2) 35x48x7mm, MVQ (50-319161-00) NA5139 32x45x6mm, FPM (50-319449-00) NA5140 91x111x10mm, FPM (50-319450-00)		











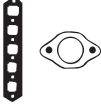

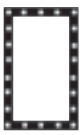

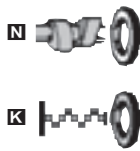









































CHRYSLER



KW/PS



Neon 2.0L 16V						06/94 → 08/99	12			
ECC	1996	4	87.50	DOHC		100/ 104/ 136/ 141				
420T	1996	4	87.50	Injection, DOHC		109/148				
Neon 2.0L 16V R/T						10/01 →	13	AC5550 (MLS) (30-029533-00)		
ECH	1996	4	87.50	DOHC		110/150				
PT Cruiser 1.6L						11/01 →	14	AC5920 (MLS), 0.65mm (30-029488-00)	CC5920 (21-29489-20/0)	EC5921 (22-29488-01/0) →07/04
EJD	1598	4	77.00	SOHC		85/116				
PT Cruiser 2.0L						10/04 →	15	AC5720 (MLS) (30-029536-00)	CC5720○ (21-29536-20/0)	
ECC	1996	4	87.50	DOHC		100/ 104/ 136/ 141				
PT Cruiser 2.0L						06/00 →	16	AC5560 (MLS) (30-029574-00) →12/01 AC5720 (MLS) (30-029536-00) 01/02 →	CC5562 (21-29574-20/0) →12/01 CC5720○ (21-29536-20/0) 01/02 →	
ECC	1996	4	87.50	DOHC		100/ 104/ 136/ 141				
PT Cruiser 2.2L CRD Diesel						03/02 →	17	AC5620 (MLS), 1.20mm 30-029263-00		
EDJ	2148	4	88.00	Direct Injection, DOHC		89/121				
PT Cruiser 2.2L CRD Diesel						08/05 →	18			
	2148	4				110/150				
PT Cruiser 2.4L						06/00 →	19	AC5570 (MLS)		
EDZ	2429	4	87.50	DOHC		105- 112/ 143- 152				
PT Cruiser Cabriolet 2.4L						03/04 →	20	AC5570 (MLS)		
EDZ	2429	4	87.50	DOHC		105- 112/ 143- 152				
Saratoga 3.0L						09/89 → 12/95	21	BR600 (Graphite) (x2) (30-028200-00)	DR600 (21-28200-20/0)	GR600
6672	2972	6	91.10	SOHC, V6		106/144				
Sebring 2.0L						04/01 →	22	AC5560 (MLS) (30-029574-00) →12/01 AC5720 (MLS) (30-029536-00) 01/02 →	DR600 (21-28200-20/0)	GR600
Sebring Convertible 2.0L						04/01 →				
ECC	1996	4	87.50	DOHC		100/ 104/ 136/ 141				

								
HBS279 ⊕ (22-290188) M11x1.50x154mm (x6) M11x1.50x109mm (x4)								 AC5550  AC5560  AC5570  AC5620  AC5720  AC5920  BR600  JM5119  JH5051  JH5060
HBS391 (22-29022B) 01/94→			JH5060 (31-029627-00)	HR5061  (24-31944-50/0)	NA NC006 (x2) 35x48x7mm, MVQ (50-319161-00) NA NA5139  32x45x6mm, FPM (50-319449-00) NA NA5140  91x111x10mm, FPM (50-319450-00)			 AC5620  AC5720  AC5920  BR600  JM5119  JH5051  JH5060
	JD5826  (x4) (50-030260-00) (Rubber) JD5827  (31-030261-00) (Rubber/Metal)	JM5119 (50-029489-00)	JH5051 (31-029592-00)		NA NA5139  32x45x6mm, FPM (50-319449-00) NA NA5140  91x111x10mm, FPM (50-319450-00)			 AC5920  BR600  JM5119  JH5051  JH5060
HBS279 ⊕ (22-290188) M11x1.50x154mm (x6) M11x1.50x109mm (x4)			JH5060 (31-029627-00)	HR5061  (24-31944-50/0)	NA NC006 35x48x7mm, MVQ (50-319161-00) NA NA5139  32x45x6mm, FPM (50-319449-00) NA NA5140  91x111x10mm, FPM (50-319450-00)			 BR600  JM5119  JH5051  JH5060
HBS279 ⊕ (22-290188) M11x1.50x154mm (x6) M11x1.50x109mm (x4)			JH5060 (31-029627-00)	HR5061  (24-31944-50/0)	NA NC006 (x2) 35x48x7mm, MVQ (50-319161-00) NA NA5139  32x45x6mm, FPM (50-319449-00) NA NA5140  91x111x10mm, FPM (50-319450-00)			 JH5051  JH5060
HBS292 ⊕ (22-26011B) M12x1.75x102mm (x10)								
HBS292 ⊕ (22-26011B) M12x1.75x102mm (x10)								
HBS279 ⊕ (22-290188) M11x1.50x154mm (x6) M11x1.50x109mm (x4)		JM5119 (50-029489-00)	JH5060 (31-029627-00)	HR5061  (24-31944-50/0)	NA NC006 (x2) 35x48x7mm, MVQ (50-319161-00) NA NA5139  32x45x6mm, FPM (50-319449-00) NA NA5140  91x111x10mm, FPM (50-319450-00)			
HBS279 ⊕ (22-290188) M11x1.50x154mm (x6) M11x1.50x109mm (x4)		JM5119 (50-029489-00)	JH5060 (31-029627-00)	HR5061  (24-31944-50/0)	NA NC006 35x48x7mm, MVQ (50-319161-00) NA NA5139  32x45x6mm, FPM (50-319449-00) NA NA5140  91x111x10mm, FPM (50-319450-00)			
HBS279 ⊕ (22-290188) M11x1.50x154mm (x6) M11x1.50x109mm (x4)			JH5060 (31-029627-00)	HR5061  (24-31944-50/0)	NA NC006 (x2) 35x48x7mm, MVQ (50-319161-00) NA NA5139  32x45x6mm, FPM (50-319449-00) NA NA5140  91x111x10mm, FPM (50-319450-00)			











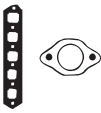

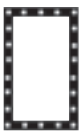

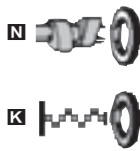

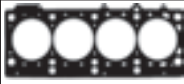



















CHRYSLER



KW/PS



Sebring 2.4L						04/01 →	23	AC5570 (MLS)		
EDZ	2429	4	87.50	DOHC		105-112/ 143-152				
Sebring 2.4L						01/95 →12/01	24	AC5560 (MLS) (30-029574-00)	CC5560	EC5560
148	2429	4	87.50	DOHC						
Stratus 2.0L 16V						12/95 →	25	AC5550 (MLS) (30-029533-00)	CC5550 (21-29533-20/0)	
Stratus 2.0L LE						12/95 →04/01				
Stratus Convertible 2.0L LE						06/96 →04/01				
C00	1995	4		Injection, SOHC		96-98/ 131-133				
420X	1996	4	87.50	DOHC		96/131				
ECB	1996	4	87.50			96-98/ 131-133				
Stratus 2.4L						01/95 →12/01	26	AC5560 (MLS) (30-029574-00)	CC5560	EC5560
148	2429	4	87.50	DOHC						
Stratus 2.4L 16 V						12/95 →04/01	27	AC5570 (MLS)		
Stratus 2.4L 16V						12/95 →				
EDZ	2429	4	87.50	DOHC		105-112/ 143-152				
Stratus 2.5L LX V6						12/95 →04/01	28			
Stratus 2.5L V6						12/95 →				
Stratus Convertible 2.5L LX						04/96 →04/01				
H00	2497	6	83.50	DOHC, V6		118/160				
EEB	2497	6	83.50	DOHC, V6		118-120/ 161-163				
625H	2499	6	83.50			120/163				
Voyager 2.0L i						01/95 →03/01	29	AC5550 (MLS) (30-029533-00)	CC5550 (21-29533-20/0)	
C00	1995	4		Injection, SOHC		96-98/ 131-133				
Voyager 2.4L						02/00 →	30	AC5570 (MLS)		EC5560
EDZ	2429	4	87.50	DOHC		105-112/ 143-152				
Voyager 2.4L i						01/95 →03/01	31			EC5560
B00	2429	4	87.50			103/140				

								 AC5550
HBS279  (22-29018B) M11x1.50x154mm (x6) M11x1.50x109mm (x4)			JM5119 (50-029489-00)	JH5060 (31-029627-00)	HR5061  (24-31944-50/0)	NC006 (x2) 35x48x7mm, MVQ (50-319161-00) NA5139  32x45x6mm, FPM (50-319449-00) NA5140  91x111x10mm, FPM (50-319450-00)		 AC5560  AC5570
HBS279  (22-29018B) M11x1.50x154mm (x6) M11x1.50x109mm (x4)								 JM5119
HBS391 (22-29022B) 01/94 →			HM5225 	JH5060 (31-029627-00)	HR5061  (24-31944-50/0)	NC006 (x2) 35x48x7mm, MVQ (50-319161-00) NA5139  32x45x6mm, FPM (50-319449-00) NA5140  91x111x10mm, FPM (50-319450-00)		 JH5060
HBS279  (22-29018B) M11x1.50x154mm (x6) M11x1.50x109mm (x4)								
HBS279  (22-29018B) M11x1.50x154mm (x6) M11x1.50x109mm (x4)			JM5119 (50-029489-00)	JH5060 (31-029627-00)	HR5061  (24-31944-50/0)	NC006 (x2) 35x48x7mm, MVQ (50-319161-00) NA5139  32x45x6mm, FPM (50-319449-00) NA5140  91x111x10mm, FPM (50-319450-00)		
	JD5759 		JM5247  (x2) →12/99 H00					
HBS391 (22-29022B) 01/94 →			HM5225 	JH5060 (31-029627-00)	HR5061  (24-31944-50/0)	NC006 35x48x7mm, MVQ (50-319161-00) NA5139  32x45x6mm, FPM (50-319449-00) NA5140  91x111x10mm, FPM (50-319450-00)		
HBS279  (22-29018B) M11x1.50x154mm (x6) M11x1.50x109mm (x4)			JM5119 (50-029489-00)	JH5060 (31-029627-00)	HR5061  (24-31944-50/0)	NC006 (x2) 35x48x7mm, MVQ (50-319161-00) NA5139  32x45x6mm, FPM (50-319449-00) NA5140  91x111x10mm, FPM (50-319450-00)		
HBS280  (22-29017B) M11x1.50x145mm (x10)								

CHRYSLER



KW/PS

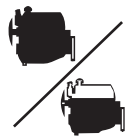

Voyager 2.5L TDiC AWD Mk II Diesel		10/95 → 03/01		32		AG9660 (MLS), 1.32mm	CG9660▲	EG9660
Voyager 2.5L CRD Diesel		02/00 →				AG9670 (MLS), 1.42mm		FG9660▲
ENC	2499	4	92.00	Indirect Injection, SOHC	85-105/ 116- 141	AG9680 (MLS), 1.52mm		
ENJ	2499	4	92.00	Indirect Injection, SOHC	105/143			
Voyager 2.5L TD Diesel		01/95 → 03/01		33		AY400 (MLS), 1.42mm, 0 Notches (30-028472-00)	DK573▲ [105] (21-28472-20/0)	GK573▲ [8] (20-28472-00/0)
425 CLIRS/X	2499	4	92.00	Indirect Injection, OHV	85/116	AY410 (MLS), 1.52mm, 2 Notches (30-028473-00)		
						AY420 (MLS), 1.62mm, 1 Notch (30-028474-00)		
Voyager 2.5L TD Diesel		01/92 → 09/95		34		BK570 (Fibre), 1.42mm, 0 Notches (x4) (30-025008-20)	DK570▲ [7] (21-25850-21/0)	GK572▲ [8] (20-25850-01/0)
M00 (HR 425 CL)	2499	4	92.00	OHV	85-87/ 116- 118	BP260 (Fibre), 1.52mm, 2 Notches (x4) (30-025013-20)		
09B	2500	4		Indirect Injection, OHV	87/118	BK580 (Fibre), 1.62mm, 1 Notch (x4) (30-025007-20)		
Voyager 2.5LTD Diesel		01/95 →		35		AY400 (MLS), 1.42mm, 0 Notches (30-028472-00)	DK573▲ [105] (21-28472-20/0)	GK573▲ [8] (20-28472-00/0)
425 CLIEE	2499	4	92.00	OHV, Turbo		AY410 (MLS), 1.52mm, 2 Notches (30-028473-00)		
						AY420 (MLS), 1.62mm, 1 Notch (30-028474-00)		
Voyager 3.0L		01/95 → 03/01		36		BR600 (Graphite) (x2) (30-028200-00)	DR600 (21-28200-20/0)	GR600
Voyager 3.0L i		08/84 → 09/95						
300	2972	6		Injection, SOHC	108/147			
	2972	6			112/152			
6672	2972	6	91.10	SOHC, V6	106/144			
Voyager 3.3L i		08/90 → 03/01		37		AC5590 (Fibre) ☒ (30-029535-00)	CC5580 (21-29534-20/0)	
Voyager 3.3L i AWD		08/90 → 09/95				AC5580 (Fibre) ☒ (30-029534-00)		
EGA	3301	6	93.00	V6	110- 128/ 150- 174			
ROO (201)	3301	6	93.00	OHV, V6	112/152			

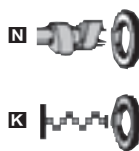
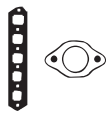

AC5580



AY400, AY410,
AY420



BK570, BP260,
BK580



BR600



JC928



JD025



JD5144

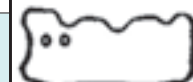

JN713



JP068

JD5875
(MLS)

JM7049
(Steel Elastomer)

HBS108®
(22-56003B)
M14x2.0x137mm (x10)
M12x1.75x115mm (x4)
M12x1.75x79.5mm (x4)

JD5144
(31-028425-00)

JP068
(31-029626-00)

HBS108®
(22-56003B)
M14x2.0x137mm (x10)
M12x1.75x115mm (x4)
M12x1.75x79.5mm (x4)









JC928 (x4)
(31-025852-10)
JD025 (x4)
(31-025849-10)









HBS108®
(22-56003B)
M14x2.0x137mm (x10)
M12x1.75x115mm (x4)
M12x1.75x79.5mm (x4)









JD5144
(31-028425-00)

JP068 [9]
(31-029626-00)

JN713
(50-028201-00)

		CC			9			CC			9
1580 SPI	Petrol	1581	4	86.40	144	DW10UTD (RHV)	Diesel	1997	4	85.00	134
1KR-FE	Petrol	998	3	71.00	42	DW10UTED4 (RHK)	Diesel	1997	4	85.00	151
220 A2.000	Petrol	1581	4	86.40	144	DW12TED (4HY)	Diesel	2179	4	85.00	136
4HT (DW12BTED4)	Diesel	2179	4	85.00	95	DW12TED4 (4HW)	Diesel	2179	4	85.00	103
8140.43C	Diesel	2798	4	94.40	143	DW12TED4/FAP (4HX)	Diesel	2179	4	85.00	95
8140.43N	Diesel	2798	4	94.40	142	DW8 (WJZ) / DW8B (WJY)	Diesel	1868	4	82.20	146
8140.43S	Diesel	2798	4	94.40	141	DW8 (WJZ) / DW8B (WJY)	Diesel	1868	4	82.20	23
8140.63	Diesel	2798	4	94.40	140	DW8 (WJZ) / DW8B (WJY)	Diesel	1868	4	82.20	230
829.A5	Petrol	1995	4	88.00	105	DW8B (WJY)	Diesel	1868	4	82.20	23
A06/635	Petrol	602	2	74.00	1	DW8B (WJY)	Diesel	1868	4	82.20	230
A06/635	Petrol	602	2	74.00	157	E1A	Petrol	1118	4	74.00	47
A06/664	Petrol	602	2	74.00	1	ES9A (XFV)	Petrol	2946	6	87.00	96
B22/615 (CRD90)	Diesel	2175	4	90.00	73	ES9J4 (XFZ)	Petrol	2946	6	87.00	205
B25/637	Diesel	2500	4	93.00	74	ES9J4 (XFZ)	Petrol	2946	6	87.00	216
C1A	Petrol	954	4	70.00	3	ES9J4S	Petrol	2946	6	87.00	97
C3A (TU9)	Petrol	954	4	70.00	155	ES9J4S (XFW)	Petrol	2946	6	87.00	104
C3A (TU9)	Petrol	954	4	70.00	3	ES9J4S (XFW)	Petrol	2946	6	87.00	96
CRD93L (U25/661)	Diesel	2500	4	93.00	64	ET3J4 (KFU)	Petrol	1360	4	75.00	57
CRD93LS (U25/673)	Diesel	2500	4	93.00	65	ET3J4 (KFU)	Petrol	1360	4	75.00	68
DHV (XUD9BSD)	Diesel	1905	4	83.00	232	ET3J4 (KFU)	Petrol	1360	4	75.00	75
DJ5 (T9A)	Diesel	2446	4	92.00	137	EW10A	Petrol	1997	4	85.00	80
DJ5T (T8A)	Diesel	2446	4	92.00	138	EW10A	Petrol	1997	4	85.00	89
DJ5TED (THX)	Diesel	2446	4	92.00	139	EW10A (RFJ)	Petrol	1997	4	85.00	80
DK5ATE (THY)	Diesel	2446	4	92.00	214	EW10A (RFJ)	Petrol	1997	4	85.00	90
DV4TD	Diesel	1398	4	73.70	43	EW10A (RFJ)	Petrol	1997	4	85.00	99
DV4TD (8HX)	Diesel	1398	4	73.70	217	EW10D (RLZ)	Petrol	1997	4	85.00	91
DV4TD (8HX)	Diesel	1398	4	73.70	58	EW10J4 (RFN)	Petrol	1997	4	85.00	126
DV4TD (8HX)	Diesel	1398	4	73.70	70	EW10J4 (RFN)	Petrol	1997	4	85.00	148
DV4TED4 (8HY)	Diesel	1398	4	73.70	69	EW10J4 (RFN)	Petrol	1997	4	85.00	235
DV6ATED4	Diesel	1560	4	75.00	19	EW10J4 (RFN)	Petrol	1997	4	85.00	81
DV6ATED4 (9HX)	Diesel	1560	4	75.00	72	EW10J4 (RFN)	Petrol	1997	4	85.00	88
DV6ATED4 (9HX)	Diesel	1560	4	75.00	78	EW10J4 (RFN)	Petrol	1997	4	85.00	98
DV6B	Diesel	1560	4	75.00	19	EW10J4S	Petrol	1997	4	85.00	80
DV6B	Diesel	1560	4	75.00	20	EW10J4S (RFK)	Petrol	1997	4	85.00	80
DV6TED4	Diesel	1560	4	75.00	223	EW12J4 (3FZ)	Petrol	2230	4	86.00	102
DV6TED4	Diesel	1560	4	75.00	72	EW7A (6FY)	Petrol	1749	4	82.70	79
DV6TED4	Diesel	1560	4	75.00	78	EW7A (6FY)	Petrol	1749	4	82.70	85
DV6TED4	Diesel	1560	4	75.00	83	EW7J4 (6FZ)	Petrol	1749	4	82.70	229
DV6TED4 (9HY)	Diesel	1560	4	75.00	78	EW7J4 (6FZ)	Petrol	1749	4	82.70	84
DV6TED4 (9HY)	Diesel	1560	4	75.00	83	G11/631	Petrol	1129	4	74.00	13
DV6TED4 (9HZ)	Diesel	1560	4	75.00	78	G1A	Petrol	1294	4	76.50	49
DW10ATED (RHS)	Diesel	1997	4	85.00	87	J6TA	Petrol	2165	4	88.00	106
DW10ATED (RHS)	Diesel	1997	4	85.00	94	K1G	Petrol	1360	4	75.00	31
DW10ATED (RHZ)	Diesel	1998	4	85.00	127	M25/629	Diesel	2500	4	93.00	111
DW10ATED (RHZ)	Diesel	1998	4	85.00	149	M25/659	Petrol	2500	4	93.00	109
DW10ATED (RHZ)	Diesel	1998	4	85.00	150	M25/660	Diesel	2500	4	93.00	107
DW10ATED (RHZ)	Diesel	1998	4	85.00	199	M25/662	Petrol	2500	4	93.00	110
DW10ATED (RHZ)	Diesel	1998	4	85.00	236	M25/667	Petrol	2498	4	93.00	110
DW10ATED (RHZ)	Diesel	1998	4	85.00	87	M25/668	Petrol	2498	4	93.00	109
DW10ATED (RHZ)	Diesel	1998	4	85.00	92	M25/669	Diesel	2500	4	93.00	108
DW10ATED (RHZ)	Diesel	1998	4	85.00	94	M25-648	Diesel	2500	4	93.00	108
DW10ATED4 (RHM)	Diesel	1997	4	85.00	100	M28 (AM2)	Petrol	602	2	74.00	121
DW10ATED4 (RHT)	Diesel	1997	4	85.00	100	M28 (AM2)	Petrol	602	2	74.00	2
DW10ATED4 (RHW)	Diesel	1997	4	85.00	100	M28/1 (AK2)	Petrol	602	2	74.00	1
DW10BTED (RHX)	Diesel	1997	4	85.00	152	M28/1 (AK2)	Petrol	602	2	74.00	121
DW10BTED4	Diesel	1997	4	85.00	82	M28/1 (AK2)	Petrol	602	2	74.00	157
DW10BTED4	Diesel	1997	4	85.00	86	TU1 (H1A)	Petrol	1124	4	72.00	238
DW10BTED4	Diesel	1997	4	85.00	93	TU1 (H1A)	Petrol	1124	4	72.00	4
DW10BTED4 (RHJ)	Diesel	1997	4	85.00	82	TU1 (H1A)	Petrol	1124	4	72.00	238
DW10BTED4 (RHR)	Diesel	1997	4	85.00	101	TU1 (H1B)	Petrol	1124	4	72.00	4
DW10BTED4 (RHR)	Diesel	1997	4	85.00	151	TU1 (H1B)	Petrol	1124	4	72.00	4
DW10BTED4 (RHR)	Diesel	1997	4	85.00	82	TU1CP (HAZ)	Petrol	1124	4	72.00	4
DW10BTED4 (RHR)	Diesel	1997	4	85.00	86	TU1JP (HFX)	Petrol	1124	4	72.00	15
DW10TD	Diesel	1997	4	85.00	25	TU1JP (HFX)	Petrol	1124	4	72.00	170
DW10TD	Diesel	1997	4	85.00	26	TU1JP (HFX)	Petrol	1124	4	72.00	55
DW10TD (RHY)	Diesel	1998	4	85.00	199	TU1JP (HFX)	Petrol	1124	4	72.00	66
DW10TD (RHY)	Diesel	1998	4	85.00	236	TU1M (H1A)	Petrol	1124	4	72.00	15
DW10TD (RHY)	Diesel	1998	4	85.00	26	TU1M (H1A)	Petrol	1124	4	72.00	170
DW10TD (RHY)	Diesel	1998	4	85.00	92	TU1M (H1A)	Petrol	1124	4	72.00	171
DW10TD (RHY)	Diesel	1998	4	85.00	92	TU1M (H1A)	Petrol	1124	4	72.00	237

		CC			9			CC			9
TU1M (H1A)	Petrol	1124	4	72.00	27	TUD3 (K9A/K9Y)	Diesel	1360	4	75.00	242
TU1M (H1A)	Petrol	1124	4	72.00	4	TUD3 (K9Y)	Diesel	1360	4	75.00	11
TU1M (H1A)	Petrol	1124	4	72.00	48	TUD3 (K9Y)	Diesel	1360	4	75.00	242
TU2.4 (M4A)	Petrol	1294	4	75.00	5	TUD5 (VJY)	Diesel	1527	4	77.00	12
TU3 (K3A)	Petrol	1360	4	75.00	50	TUD5 (VJY)	Diesel	1527	4	77.00	173
TU3A (K1H)	Petrol	1360	4	75.00	240	TUD5 (VJY)	Diesel	1527	4	77.00	244
TU3A (K1H)	Petrol	1360	4	75.00	29	TUD5 (VJZ)	Diesel	1527	4	77.00	12
TU3A (K1H)	Petrol	1360	4	75.00	50	TUD5 (VJZ)	Diesel	1527	4	77.00	173
TU3CP (KAY)	Petrol	1360	4	75.00	241	TUD5 (VJZ)	Diesel	1527	4	77.00	219
TU3CP (KAY)	Petrol	1360	4	75.00	7	TUD5 (VJZ)	Diesel	1527	4	77.00	244
TU3F2 (K1F)	Petrol	1360	4	75.00	240	V06/630	Petrol	652	2	77.00	154
TU3F2 (K1F)	Petrol	1360	4	75.00	7	V06/630	Petrol	652	2	77.00	185
TU3F2 (K2B)	Petrol	1360	4	75.00	240	V06/644	Petrol	652	2	77.00	154
TU3F2 (K2B)	Petrol	1360	4	75.00	8	V06/644	Petrol	652	2	77.00	185
TU3FJ2 (K2D)	Petrol	1360	4	75.00	189	V06/665	Petrol	647	2	77.00	184
TU3FJ2 (K2D)	Bi-Fuel	1360	4	75.00	17	XM7T (169)	Petrol	1796	4	84.00	61
TU3FJ2 (KFY)	Petrol	1360	4	75.00	6	XN1T (170A)	Petrol	1971	4	88.00	63
TU3FJ2 (KFZ)	Petrol	1360	4	75.00	6	XN1T (170B)	Petrol	1971	4	88.00	63
TU3FM (K2A)	Petrol	1360	4	75.00	240	XN1T (170C)	Petrol	1971	4	88.00	63
TU3FM (K2A)	Petrol	1360	4	75.00	8	XU102C (R2A)	Petrol	1998	4	86.00	135
TU3FM (KDY)	Petrol	1360	4	75.00	189	XU102C (R2A)	Petrol	1998	4	86.00	208
TU3FM (KDY)	Petrol	1360	4	75.00	52	XU10J2	Petrol	1998	4	86.00	133
TU3FM (KDY)	Bi-Fuel	1360	4	75.00	17	XU10J2	Bi-Fuel	1998	4	86.00	133
TU3JP (KFW)	Petrol	1360	4	75.00	16	XU10J2 (RFU)	Petrol	1998	4	86.00	124
TU3JP (KFW)	Petrol	1360	4	75.00	172	XU10J2 (RFW)	Petrol	1998	4	86.00	133
TU3JP (KFW)	Petrol	1360	4	75.00	189	XU10J2 (RFZ)	Petrol	1998	4	86.00	207
TU3JP (KFW)	Petrol	1360	4	75.00	218	XU10J2C (RFX)	Petrol	1998	4	86.00	200
TU3JP (KFW)	Bi-Fuel	1360	4	75.00	17	XU10J2C (RFX)	Petrol	1998	4	86.00	253
TU3JP (KFX)	Petrol	1360	4	75.00	16	XU10J2TE (RGX)	Petrol	1998	4	86.00	129
TU3JP (KFX)	Petrol	1360	4	75.00	172	XU10J2TE (RGX)	Petrol	1998	4	86.00	203
TU3JP (KFX)	Petrol	1360	4	75.00	189	XU10J2TE (RGX)	Petrol	1998	4	86.00	210
TU3JP (KFX)	Petrol	1360	4	75.00	218	XU10J2TE (RGX/RGY)	Petrol	1998	4	86.00	210
TU3JP (KFX)	Petrol	1360	4	75.00	243	XU10J4 (RFT)	Petrol	1998	4	86.00	201
TU3JP (KFX)	Bi-Fuel	1360	4	75.00	17	XU10J4 (RFT)	Petrol	1998	4	86.00	254
TU3JP-L4	Petrol	1360	4	75.00	56	XU10J4 (RFY)	Petrol	1998	4	86.00	201
TU3JP-L4	Petrol	1360	4	75.00	67	XU10J4 (RFY)	Petrol	1998	4	86.00	254
TU3JP-L4	Bi-Fuel	1360	4	75.00	67	XU10J4R (RFV)	Petrol	1998	4	86.00	125
TU3M (KDX)	Petrol	1360	4	75.00	189	XU10J4R (RFV)	Petrol	1998	4	86.00	202
TU3M (KDX)	Petrol	1360	4	75.00	243	XU10J4R (RFV)	Petrol	1998	4	86.00	209
TU3M (KDX)	Bi-Fuel	1360	4	75.00	17	XU10J4R (RFV)	Petrol	1998	4	86.00	234
TU3M (KDY)	Petrol	1360	4	75.00	189	XU10J4RS (RFS)	Petrol	1998	4	86.00	234
TU3M (KDY)	Petrol	1360	4	75.00	243	XU10J4RS (RFS)	Petrol	1998	4	86.00	255
TU3M (KDY)	Petrol	1360	4	75.00	30	XU10MZ (RDZ)	Petrol	1998	4	86.00	206
TU3M (KDY)	Petrol	1360	4	75.00	52	XU10MZ (RDZ)	Petrol	1998	4	86.00	208
TU3M (KDY)	Bi-Fuel	1360	4	75.00	17	XU5 (171A/171B) XU5S (171C)	Petrol	1580	4	83.00	32
TU3M/Z (KDZ)	Petrol	1360	4	75.00	189	XU5 (B1AA)	Petrol	1580	4	83.00	33
TU3M/Z (KDZ)	Petrol	1360	4	75.00	239	XU51C (B1A) XU52C (B2C)	Petrol	1580	4	83.00	32
TU3M/Z (KDZ)	Petrol	1360	4	75.00	243	XU51C (B1E)	Petrol	1580	4	83.00	32
TU3M/Z (KDZ)	Petrol	1360	4	75.00	30	XU52C	Petrol	1580	4	83.00	32
TU3M/Z (KDZ)	Bi-Fuel	1360	4	75.00	17	XU5CP (BAY)	Petrol	1580	4	83.00	32
TU5J4 (NFX)	Petrol	1587	4	78.50	175	XU5CP (BAY/BAZ)	Petrol	1580	4	83.00	32
TU5JP (NFT)	Petrol	1587	4	78.50	174	XU5J (180A/B6D)	Petrol	1580	4	83.00	190
TU5JP (NFT/NFZ)	Petrol	1587	4	78.50	174	XU5J (180Z)	Petrol	1580	4	83.00	32
TU5JP (NFT/NFZ)	Petrol	1587	4	78.50	220	XU5J/J2/JA	Petrol	1580	4	83.00	32
TU5JP (NFT/NFZ)	Petrol	1587	4	78.50	245	XU5JA (B6D)	Petrol	1580	4	83.00	190
TU5JP4 (NFU/N6A)	Petrol	1587	4	78.50	18	XU5JP (BFZ)	Petrol	1580	4	83.00	192
TU5JP4 (NFU/N6A)	Petrol	1587	4	78.50	221	XU5JP (BFZ)	Petrol	1580	4	83.00	246
TU5JP4 (NFU/N6A)	Petrol	1587	4	78.50	59	XU5M (BDY/B4A)	Petrol	1580	4	83.00	246
TU5JP4 (NFU/N6A)	Petrol	1587	4	78.50	71	XU5M (BDY/B4A)	Petrol	1580	4	83.00	32
TU5JP4 (NFU/N6A)	Petrol	1587	4	78.50	76	XU5M (BDZ)	Petrol	1580	4	83.00	32
TU5JP4 (NFU/N6A)	Petrol	1587	4	78.50	77	XU5S (171D)	Petrol	1580	4	83.00	32
TU5JP4S (NFS)	Petrol	1587	4	78.50	60	XU7JB (LFX)	Petrol	1761	4	83.00	194
TU9	Petrol	954	4	70.00	45	XU7JB (LFX)	Petrol	1761	4	83.00	21
TU9 (C1A)	Petrol	954	4	70.00	186	XU7JB (LFX)	Petrol	1761	4	83.00	225
TU9 (C1A)	Petrol	954	4	70.00	3	XU7JP (LFW/LFZ/L6A)	Petrol	1761	4	83.00	122
TU9M (CDY/CDZ)	Petrol	954	4	70.00	169	XU7JP (LFW/LFZ/L6A)	Petrol	1761	4	83.00	193
TU9M (CDY/CDZ)	Petrol	954	4	70.00	186	XU7JP (LFW/LFZ/L6A)	Petrol	1761	4	83.00	227
TU9M (CDY/CDZ)	Petrol	954	4	70.00	3	XU7JP (LFW/LFZ/L6A)	Petrol	1761	4	83.00	248
TUD3 (K9A/K9Y)	Diesel	1360	4	75.00	11	XU7JP4 (LFY)	Petrol	1761	4	83.00	195

		CC			9			CC			9
XU7JP4 (LFY)	Petrol	1761	4	83.00	226	XW7 (109K)	Petrol	1124	4	72.00	47
XU7JP4 (LFY)	Petrol	1761	4	83.00	229	XY6 (150F) / XY8 (150A)	Petrol	1360	4	75.00	31
XU7JP4 (LFY)	Petrol	1761	4	83.00	249	XY6C (150A)	Petrol	1360	4	75.00	31
XU92C (D2A)	Petrol	1905	4	83.00	36	XY6D (150C)	Petrol	1360	4	75.00	31
XU92C (D2C)	Petrol	1905	4	83.00	37	XY7 (150D)	Petrol	1360	4	75.00	188
XU92C (D2F)	Petrol	1905	4	83.00	39	XY7 (150D)	Petrol	1360	4	75.00	51
XU9J1 (DFZ)	Petrol	1905	4	83.00	39	XY8 (150B)	Petrol	1360	4	75.00	188
XU9J2 (D6A)	Petrol	1905	4	83.00	39	ZPJ/Z (SFZ)	Petrol	2963	6	93.00	215
XU9J4 (D6C/DFW)	Petrol	1905	4	83.00	41	ZPJ/Z (UFZ)	Petrol	2963	6	93.00	215
XU9J4 (DFW)	Petrol	1905	4	83.00	41	ZPJ4 (SKZ)	Petrol	2963	6	93.00	215
XU9JA (DKZ)	Petrol	1905	4	83.00	251	ZPJ4 (UKZ)	Petrol	2963	6	93.00	215
XU9JA (DKZ)	Petrol	1905	4	83.00	38						
XU9M (DDZ)	Petrol	1905	4	83.00	39						
XU9S (159A)	Petrol	1905	4	83.00	36						
XUD11A (P9A/PJZ)	Diesel	2138	4	86.00	211						
XUD11ATE (P8A)	Diesel	2088	4	85.00	212						
XUD11ATE (P8A)	Diesel	2088	4	85.00	213						
XUD11ATE (PHZ)	Diesel	2088	4	85.00	212						
XUD11ATE (PHZ)	Diesel	2088	4	85.00	213						
XUD11ATE (PJZ)	Diesel	2088	4	85.00	212						
XUD11ATE (PJZ)	Diesel	2088	4	85.00	213						
XUD11BTE (P8C)	Diesel	2088	4	85.00	130						
XUD11BTE (P8C)	Diesel	2088	4	85.00	204						
XUD11BTE (P8C)	Diesel	2088	4	85.00	212						
XUD11BTE (P8C)	Diesel	2088	4	85.00	213						
XUD7 (161)	Diesel	1769	4	80.00	34						
XUD7 (161A)	Diesel	1769	4	80.00	191						
XUD7 (161A)	Diesel	1769	4	80.00	224						
XUD7 (161A)	Diesel	1769	4	80.00	247						
XUD7 (161A)	Diesel	1769	4	80.00	34						
XUD7 (161A)	Diesel	1769	4	80.00	53						
XUD7 (A9A/161A)	Diesel	1769	4	80.00	22						
XUD7 (A9A/161A)	Diesel	1769	4	80.00	224						
XUD7TE (A8A)	Diesel	1769	4	80.00	35						
XUD7TE (AJZ)	Diesel	1769	4	80.00	35						
XUD9 (162)	Diesel	1905	4	83.00	40						
XUD9 (D9B/DJZ)	Diesel	1905	4	83.00	40						
XUD9 (DJZ/D9B/DJY)	Diesel	1905	4	83.00	196						
XUD9 (DJZ/D9B/DJY)	Diesel	1905	4	83.00	250						
XUD9A (DJY/D9B)	Diesel	1905	4	83.00	131						
XUD9A (DJY/D9B)	Diesel	1905	4	83.00	231						
XUD9A (DJY/D9B)	Diesel	1905	4	83.00	24						
XUD9A/L (D9B)	Diesel	1905	4	83.00	196						
XUD9A/L (D9B)	Diesel	1905	4	83.00	24						
XUD9A/U (D9B)	Diesel	1905	4	83.00	131						
XUD9A/U (D9B)	Diesel	1905	4	83.00	145						
XUD9A/U (D9B)	Diesel	1905	4	83.00	250						
XUD9A/U (D9B)	Diesel	1905	4	83.00	40						
XUD9A/U (D9B)	Diesel	1905	4	83.00	62						
XUD9SD (DHW)	Diesel	1905	4	83.00	197						
XUD9TE (D8C/DHX)	Diesel	1905	4	83.00	132						
XUD9TE (DHY/D8A)	Diesel	1905	4	83.00	198						
XUD9TE (DHY/D8A)	Diesel	1905	4	83.00	233						
XUD9TE (DHY/D8A)	Diesel	1905	4	83.00	252						
XUD9TF (D8B)	Diesel	1905	4	83.00	123						
XUD9TF (D8B)	Diesel	1905	4	83.00	147						
XUD9TF (D8B)	Diesel	1905	4	83.00	198						
XUD9TF/BTF (DHX)	Diesel	1905	4	83.00	123						
XUD9TF/BTF (DHX)	Diesel	1905	4	83.00	132						
XUD9TF/BTF (DHX)	Diesel	1905	4	83.00	147						
XUD9TF/BTF (DHX)	Diesel	1905	4	83.00	198						
XV8 (108C)	Petrol	954	4	70.00	186						
XV8 (108C)	Petrol	954	4	70.00	44						
XV8 (108C)	Petrol	954	4	70.00	45						
XW7 (109/5)	Petrol	1124	4	72.00	187						
XW7 (109/5E)	Petrol	1124	4	72.00	156						
XW7 (109/5F)	Petrol	1124	4	72.00	187						
XW7 (109K)	Petrol	1124	4	72.00	187						
XW7 (109K)	Petrol	1124	4	72.00	46						

Type Mines OU C.N.I.T.*	Encadré N°	Type Mines OU C.N.I.T.*	Encadré N°	Type Mines OU C.N.I.T.*	Encadré N°	Type Mines OU C.N.I.T.*	Encadré N°
2 CV		ZAZX	9	MCT1104C5064	16	MFWJYB/A	23
AK-AK	1	ZAZY	8	MCT1104C6065	16	MFWJZF	23
AZ-KA	1	Axel		MCT1104C7066	16	MFWJZF/A	23
AZ-KA4X4	1	TATB	13	MCT1104CA069	16	UCT5213CW167	19
AZ-KAA	1	TATF	14	MCT1104CB070	16	VCT000AC8095	24
Acadiane		TATG	14	MCT1104CE425	16	VCT5104C6432	23
AYCD	2	TATH	13	MCT1104CE522	16	BX	
AYU	2	TATJ	14	MCT1104CF426	16	HBHYA	32
AX		Berlingo		MCT1104CF523	16	HBHZ	32
MCT000AKV302	3	GB9HWC	20	MCT1104CG427	16	XBEA	32
MCT000AKW303	3	GBHFXB	15	MCT1104CH428	16	XBEB	32
MCT1001KH242	3	GBKFWB	16	MCT1104CP568	16	XBED	34
VCT000AK4302	3	GBKFWBGNV	17	MCT1104CP569	16	XBEE	32
ZADA	4	GBKFWBGPL	17	MCT1204CM423	21	XBEEBC	32
ZADAB	4	GBNFUB	18	MCT1204CN424	21	XBEG	39
ZADAC	4	GBRHYB	26	MCT1204CP195	21	XBEGA	39
ZADB	4	GBWJYB	23	MCT1204CP196	21	XBEJ	41
ZADBB	4	GBWJYBDG	23	MCT1204CQ524	21	XBEK	35
ZADBC	4	GC9HW	20	MCT1204CR525	21	XBEL	34
ZADC	4	GCKFWB	17	MCT1304C5590	18	XBEP	27
ZADD	9	GCKFWBGNV	17	MCT1304C6591	18	XBER	31
ZADDB	9	GCKFWBGPL	17	MCT5004CE071	24	XBERB	31
ZADE	9	GCNFUB	18	MCT5004CF072	24	XBERBBC	31
ZADEB	9	GCRHYB	26	MCT5004CG073	24	XBFW	39
ZADF	11	GCRHYBDG	26	MCT5103CV759	23	XBEG	35
ZADG	11	GCWJYB	23	MCT5103CW760	23	XBEX	36
ZADH	9	GEWJYB	23	MCT5104C8346	23	XBFEA	38
ZADJ	9	GJ9HW	19	MCT5104C9347	23	XBEZ	38
ZADM	6	GJ9HXC	19	MCT5104CW431	23	XBFA	32
ZADN	6	GJKFWB	17	MCT5104CW528	23	XBFC	41
ZAKE	12	GJKFWBGPL	17	MCT5104CX432	23	XBFE	39
ZAKET	12	GJRHYB	26	MCT5104CX529	23	XBFF	38
ZAKF	12	GJRHYK	25	MCT5113CA155	19	XBFG	30
ZALAT	4	GJWJYB	23	MCT5113CU369	19	XBFN	39
ZALB	10	MAHDZA	15	MCT5203C3757	25	XBFP	39
ZALC	10	MAHDZD	15	MCT5203C4758	25	XBFR	38
ZALF	10	MAHDZF	15	MCT5204C7565	25	XBFS	39
ZALG	10	MAHDZF/GPL	15	MCT5204CG502	26	XBFS	39
ZALH	3	MAHXXB	15	MCT5204CL604	25	XBFS	39
ZALJ	3	MBA9AE	22	MCT5204CM605	25	XBFS	39
ZAZA	3	MBAPAG	22	MCT5204CM605	25	XBFS	39
ZAZAB	3	MBD9BE	24	MCT5204CU649	25	XBFT	36
ZAZAE	3	MBHDZE	15	MCT5204CV650	25	XBFT	36
ZAZAR	3	MBHDZF	15	MCT5204CV650	25	XBFT	36
ZAZART	3	MBHFXWB	15	MCT5213CW167	19	XBFW	32
ZAZAT	3	MBK5AG	16	MCT6204BA009	26	XBFX	38
ZAZB	4	MBK6CG	16	MCT9113C2365	17	XBFY	39
ZAZBD	4	MBKFWB	16	MCWJYB	23	XBFYA	39
ZAZBT	4	MBKFXF	16	MCWJZF	23	XBHA	38
ZAZC	7	MBRHYB	26	MEA9AE	22	XBHC	30
ZAZCD	7	MBRHYF	26	MED9BE	24	XBHD	30
ZAZD	8	MBWJYB	23	MEWJZF	23	XBHK	39
ZAZDD	8	MBWJYP	23	MFA9AE	22	XBHKA	39
ZAZE	3	MBWJZC	23	MFD9BE	24	XBHKB	39
ZAZF	4	MBWJZF	23	MFDJYF	24	XBHL	39
ZAZH	3	MCA9AE	22	MFDJYF/A	24	XBHLA	39
ZAZHB	3	MCA9AG	22	MFHDZE	15	XBHLB	39
ZAZJ	4	MCD9BE	24	MFHDZF	15	XBHM	39
ZAZJD	4	MCKFWB	16	MFHFXB	15	XBHN	39
ZAZK	7	MCKFXF	16	MFK5AG	16	XBHP	32
ZAZKD	7	MCRHYB	26	MFK6CG	16	XBHR	35
ZAZL	5	MCRHYF	26	MFKFWB	16	XBHS	34
ZAZM	4	MCT000AC0193	21	MFKFWB/A	16	XBHY	30
ZAZN	7	MCT000AC1449	16	MFKFXB/IF	16	XBXA	31
ZAZP	4	MCT000AC2062	15	MFKFXF	16	XBXB	32
ZAZR	4	MCT000AC2450	16	MFKFXF/A	16	XBXBAA	32
ZAZS	7	MCT000AC3063	16	MFKFXF/AIF	16	XBXB	32
ZAZT	11	MCT000AC4064	24	MFKFXF/GPL	16	XBXC	40
ZAZTT	11	MCT000ACW092	16	MFLFXF	21	XBXC	40
ZAZU	11	MCT000ACX093	16	MFLFXF/A	21	XBXCA	40
ZAZV	11	MCT000ACY094	24	MFLFXF/A	21	XBXCAA	40
ZAZW	8	MCT000ACZ095	24	MFNFUB	18	XBXCE	40
		MCT000ACZ192	21	MFNFUB/A	18	XBXCT	40
				MFNFUF/A	18	XBXD	31
				MFRHYB/A	26	XBXDA	31
				MFRHYF	26	XBXDBC	31
				MFRHYF/A	26	XBXE	32
				MFWJYB	23	XBXEBC	32

* C.N.I.T. = Code National d'Identification du Type (code D2.1 sur nouvelles cartes grises)

Type Mines OU C.N.I.T.*	Encadré N°	Type Mines OU C.N.I.T.*	Encadré N°	Type Mines OU C.N.I.T.*	Encadré N°	Type Mines OU C.N.I.T.*	Encadré N°
XBXEE	32	JG8HZCT	58	290C22	63	M10CTRV000T234	66
XBXF	40	JGHFXBT	55	290C42	63	M10CTRV000X238	71
XBXFE	40	JGHFXCT	55	290C44	63	M10CTRV000Y239	71
XBXFT	40	JGKFVBT	56	290C52	64	M10CTRV000Z240	71
XBXG	36	JGNFUC/P	59	290C54	64	MCT1002P9845	66
XBXGA	36	JM8HXB	58	290C62	62	MCT1002PB944	66
XBXH	36	JM8HXB/P	58	290C92	65	MCT1002PC945	66
XBXHA	36	JM8HXC	58	290C94	65	MCT1002PD946	66
XBXK	32	JM8HXC/P	58	290G54	64	MCT1002PE681	66
XBXM	36	JM8HZB	58	290G94	65	MCT1002PJ686	66
XBXMA	36	JM8HZC	58	290J32	63	MCT1012PP145	66
XBXN	36	JM8HZC/P	58	290J42	63	MCT1101QH747	67
XBXP	34	JMHFXB	55	290K42	63	MCT1101QJ748	67
XBXR	28	JMHFXC	55	290L42	63	MCT1105Q5957	67
XBXS	32	JMKFUC/P	57	290S62	62	MCT1105QP747	67
XBXT	31	JMKFUC/PS	57	2C50BDG	64	MCT1115QX294	67
XBXTC	39	JMKFVB	56	2C90BDG	65	MCT1212P9048	68
XBXU	40	JMKFVB/P	56			MCT1212PA049	68
XBXV	40	JMNFSC	60	C3		MCT1302P2905	71
XBXW	32	JMNFUB/P	59	FC8HXB	70	MCT1302P6679	71
XBXX	32	JMNFUC	59	FC8HXB/P	70	MCT1302P6715	71
XBXYE	31	JMNFUC/P	59	FC8HXB/P	70	MCT1302P6970	71
		MCT1001R0775	55	FC8HXC	70	MCT1302P7971	71
C1		MCT1001RF973	55	FC8HYB	69	MCT1302PH920	71
MCT1001T6937	42	MCT1001RG974	55	FC8HZ	70	MCT1302PG735	71
MCT1002TA939	42	MCT1001RH975	55	FC8HZB	70	MCT1302PS967	71
MCT1011TN299	42	MCT1001RP860	55	FC8HZBT	70	MCT1302PT968	71
MCT1012TW087	42	MCT1101R3793	56	FC8HZC	70	MCT3212P3169	68
MCT3001TD938	42	MCT1101R4794	56	FC8HZC/P	70	MCT3212P4170	68
MCT3012T3088	42	MCT1101R4988	56	FC9HXC	72	MCT3302P0969	71
MCT5001TF995	43	MCT1101RU856	56	FC9HZC	72	MCT3302P9906	71
MCT5002TJ996	43	MCT1301RM828	59	FCHFVB	66	MCT3302PX736	71
MCT5011T3084	43	MCT1401RU862	60	FCHFVC	66	MCT3302PY834	71
PM8HTC	43	MCT1411RH000	60	FCHFVC/IF	66	MCT3305QX959	71
PMCFAC	42	MCT3211RA298	57	FCKFU	68	MCT3312P5028	71
PN8HTC	43	MCT3311RJ006	59	FCKFUC	68	MCT3312PH004	71
PNCFAC	42	MCT5001R3985	58	FCKFUC/P	68	MCT3312PJ005	71
UCT1001T6937	42	MCT5001R4986	58	FCKFVCGN	67	MCT3312PR050	71
UCT5011T3084	43	MCT5001R8929	58	FCNFU	71	MCT5002P0788	70
		MCT5001R9797	58	FCNFU/B	71	MCT5002P0982	70
C15		MCT5001R9930	58	FCNFUB	71	MCT5002P1983	70
VD*	50	MCT5001RN847	58	FCNFUC	71	MCT5002P4925	70
VDPA	47	MCT5001RS780	58	FCNFUC/P	71	MCT5002P5926	70
VDPB	53	MCT5001RT781	58	FL9HXC	72	MCT5002P7928	70
VDPBF	53	MCT5001RU976	58	FN8HYB	69	MCT5002P8796	70
VDPF	47	MCT5001RV977	58	FN8HZB	70	MCT5002PC678	70
VDPL	45	UCT1001RG974	55	FNHFVB	66	MCT5002PH841	70
VDPM	51	UCT1101R6990	56	FNHFVC/IF	66	MCT5002PX979	70
VDPP	53	UCT1411RH000	60	FNKFUB	68	MCT5002PY980	70
VDPPF	53	UCT5001R3985	58	FNNFUB	71	MCT5005Q2855	70
VDPS	47	UCT5001RN847	58	FR8HYB	69	MCT5005Q9923	70
VDPT	47	UCT5001RV977	58	FR8XZB	70	MCT5005QJ835	70
VDPU	49	UCT7001R2978	58	FRHFVB	66	MCT5015QE018	70
VDPV	49			FRKFVB/GNV	67	MCT5202PE951	72
VDPW	49	C25		HB8HXB	70	MCT5202PF952	72
VDPX	48	280B20	63	HB8HZB	70	MCT5202PG917	69
VDPY	48	280B20A	63	HB8HZC	70	MCT5202PH918	69
VDSA	50	280C20B	63	HBKFVB	67	MCT5202PQ830	69
VDSB	50	280C20C	63	HBKFVC	67	MCT5202PV677	69
VDSC	48	280C50	64	HBNFUB	71	MCT5212PD295	72
VDSD	45	280C50A	64	HBNFUB/P	71	MCT5312PL002	72
VDSE	48	280C50B	64	HBNFUC	71	MCT5312PM003	72
VDSG	50	280C50C	64	HBNFUC/P	71	MCT7002P5981	70
VDSJ	50	280C54B	64	M10CTRV0000241	71	MCT9012P9008	67
VDSV	48	280C90B	65	M10CTRV0001242	71	SC8HZC	70
VDSX	53	280C94B	65	M10CTRV0002243	68	SC8HZC/1	70
VDSZ	48	280G945	65	M10CTRV0004245	68	UCT1302PS967	71
VDVN	48	290A22	63	M10CTRV0005246	68	UCT5002P5926	70
VDVV	54	290A42	63	M10CTRV0006247	68	UCT5002PY980	70
VDVW	54	290B22	63	M10CTRV0008249	70	VCT1002PN681	66
VDVY	54	290B222	63	M10CTRV0009250	70	VCT5002PL678	70
		290B223	63	M10CTRV000A251	70	VCT5002PQ841	70
C2		290B42	63	M10CTRV000B252	70	VCT5202P4677	69
JG8HXB	58	290B54	64	M10CTRV000F256	72		
JG8HXB/P	58	290C11	61	M10CTRV000G257	72	C35	

* C.N.I.T. = Code National d'Identification du Type (code D2.1 sur nouvelles cartes grises)

Type Mines OU C.N.I.T.*	Encadré N°	Type Mines OU C.N.I.T.*	Encadré N°	Type Mines OU C.N.I.T.*	Encadré N°	Type Mines OU C.N.I.T.*	Encadré N°
BFBG	74	MCT5302S9897	78	DC6FZB	84	MCT3904M6648	96
C4		MCT5302SA898	78	DC6FZC	84	MCT3904MJ916	96
LA9HVC	78	MCT5311SF358	78	DC6FZE	84	MCT3904MN884	96
LA9HXC	78	MCT5311SG032	78	DC6FZF	84	MCT5202M4617	92
LA9HY	78	MCT5312SK034	78	DCRFNB	88	MCT5204M9618	92
LA9HYB	78	MCT5312SK361	78	DCRFNC	88	MCT5302M6645	92
LA9HYC	78	MCT5314VN321	78	DCRFNE	88	MCT5302MC942	83
LA9HYZ	78	MCT5316V6106	78	DCRFNF	88	MCT5302MJ913	83
LA9HZC	78	MCT5316VB402	78	DCRHYB	92	MCT5302MP531	92
LA9HZH	78	MCT5316VC403	78	DCRHZB	92	MCT5302MY867	83
LAKFUC	75	MCT5316VK156	78	DCRHZE	92	MCT5304M3868	83
LANFUC	77	MCT5316VL387	78	DCRHZF	92	MCT5304MB646	94
LANFUF	77	MCT5316VP063	78	DCRLZB	91	MCT5304MH943	83
LARFJC	81	MCT5316VP064	78	DCXFXB	96	MCT5304MP623	87
LARFKC	80	MCT5316VX388	78	DCXFXC	96	MCT5304MP914	83
LARFNC	81	MCT5501SP895	82	DCXFXE	96	MCT5312MV051	83
LARHR	82	MCT5501SU997	82	DCXFXF	96	MCT5314M3249	83
LARHRH	82	MCT5502SZ903	82	DE4HXB	95	MCT5502M5879	93
LC9HVC	78	MCT5511S1033	82	DE4HXE	95	MCT5502M6880	93
LC9HXC	78	MCT5511SV160	82	DE4HXF	95	MCT5502M8530	95
LC9HYB	78	MCT5512S5035	82	DE6FZB	84	MCT5502ME791	95
LC9HYC	78	MCT5516V4411	82	DE6FZC	84	MCT5502MG865	93
LC9HZ	78	MCT5516V5412	82	DERFNB	88	MCT5504MB881	86
LC9HZC	78	MCT5516VP396	82	DERFNC	88	MCT5504MC882	86
LCKFUC	75	MCT5611SA359	82	DERFNE	88	MCT5504MF630	95
LCNFUC	76	MCT5612SW379	82	DERFNF	88	MCT5504MJ792	95
LCNFUF	77	MCT7311S0046	78	DERHSB	94	MCT5512M2232	86
LCRFJC	80	MCT7311SZ336	78	DERHYB	92	MCT5512MY458	86
LCRFJF	80	MCT7312S3047	78	DERHXB	87	MCT5514MQ252	86
LCRFNC	81	MCT7312S8343	78	DERHZE	87	MCT5614MY383	86
LCRHR	82	MCT7316VR157	78	DERHZF	87	MCT5712M4056	95
LCRHRH	82	MCT7316VW065	78	DERLZB	91	MCT5712MM038	95
LCRHRJ	82	MCT7511SQ052	82	DERLZC	91	MCT5714M5247	95
LG9HXC	78	MCT7512ST053	82	DEXFXB	96	MCT5714MR039	95
LG9HZC	78	MCT7516V0110	82	DEXFXC	96	MCT7302MP622	92
M10CTTRVP0008188	78	MCT7516V1111	82	DEXFXE	96	MCT7304MV624	87
M10CTTRVP0008213	78	MCT7516V4308	82	DEXFXF	96	MCT7502MH885	95
M10CTTRVP000B191	78	MCT7516V5309	82	M10CTTRVP0006053	86	MCT7502ML598	95
M10CTTRVP000B216	78	MCT7516V7117	82	M10CTTRVP0007054	86	MCT7504MM631	95
M10CTTRVP000E219	78	MCT7516V7408	82	M10CTTRVP000S075	86	MCT7504MM886	95
M10CTTRVP000F220	75	MCT7516V8118	82	M10CTTRVP000T076	86	MCT7512M9233	86
M10CTTRVP000P194	78	MCT7516V8409	82	MCT1402M0580	84	MCT7512MZ029	93
M10CTTRVP000P229	82	MCT7516VC158	82	MCT1402MD873	84	MCT7514M4030	86
M10CTTRVP000R195	75	MCT7516VC413	82	MCT1402MZ579	84	MCT7514MX253	86
M10CTTRVP000Z204	82	MCT7516VD159	82	MCT1404MK876	84	MCT7712M0082	95
MCT1201SE890	75	MCT7516VK069	82	MCT1404MX634	84	MCT7712MY080	95
MCT1202SP899	75	MCT7516VS393	82	MCT1404MY635	84	MCT7714M3081	95
MCT1301SP891	77	MCT7516VT103	82	MCT1502M0595	88	RC4HPPH	95
MCT1301SQ892	77	MCT7516VT394	82	MCT1502M7771	88	RC4HRJ	95
MCT1302S0900	77	MCT7516VU104	82	MCT1502MY593	88	RC4HSJ	95
MCT1302S1901	77	MCT7516VW397	82	MCT1504M5632	88	RC4HTH	95
MCT1501SC894	81	MCT9311SG214	77	MCT1504MC772	88	RC4HXE	95
MCT1502SM902	81	MCT9312SJ215	76	MCT1512M2014	85	RC6FYC	85
MCT1516VD105	79	UA6FYC	79	MCT1512MB095	85	RC6FZB	84
MCT1516VV062	79	UA9HYB	78	MCT1514M7015	85	RC6FZC/IF	84
MCT1611SR025	81	UA9HYC	78	MCT1514MA248	85	RC9HYB	83
MCT1612SV027	80	UA9HZC	78	MCT1514MG096	85	RC9HZC	83
MCT1701SV893	80	UA9HZH	78	MCT1602MJ869	89	RCRFJC	89
MCT1711S2026	80	UARHJH	82	MCT1602MU615	88	RCRFJF	89
MCT3301S1933	77	UARHRF	82	MCT1604MP871	90	RCRHRG	93
MCT3301S2934	77	UARHRJ	82	MCT1604MZ616	88	RCRHRH	93
MCT3302S5935	77	UCT5201SN887	78	MCT1902M2532	96	RCRHRJ	93
MCT3302S6936	77	UCT5211SG236	78	MCT1904MP647	96	RCXFUJ	96
MCT3602SP924	80	UCT5301SZ889	78	MCT3402M3602	84	RCXVJ	96
MCT5201SN887	78	UCT7511SQ052	82	MCT3502M5594	88	RDRHRH	86
MCT5202SY896	78	UD6FYC	79	MCT3502MT751	88	RDRHRJ	86
MCT5211SG236	78	UD9HZC	78	MCT3504MC633	88	RE4HPH	95
MCT5211SJ335	78	UD9HZH	78	MCT3504MY752	88	RE4HRJ	95
MCT5212S7164	78	UDRHJH	82	MCT3602M5911	89	RE4HSJ	95
MCT5212S9360	78	UDRHRF	82	MCT3602MP870	89	RE4HTH	95
MCT5212SJ237	78	UDRHRJ	82	MCT3604MA912	90	RE4HXE	95
MCT5212SR342	78			MCT3604MV872	90	RE6FYC	85
MCT5212SY191	78	C5		MCT3902ME915	96	RE6FZB	84
MCT5301SY888	78	DC4HXB	95	MCT3902MJ883	96	RE6FZC/IF	84
MCT5301SZ889	78	DC4HXE	95	MCT3902MK533	96	RE9HYB	83

* C.N.I.T. = Code National d'Identification du Type (code D2.1 sur nouvelles cartes grises)

Type Mines OU C.N.I.T.*	Encadré N°	Type Mines OU C.N.I.T.*	Encadré N°	Type Mines OU C.N.I.T.*	Encadré N°	Type Mines OU C.N.I.T.*	Encadré N°
RE9HZC	83	MANP	110	231B22	133	231V52/D	137
RERFJC	90	MANR	106	231B22/B	133	231V54	137
RERFJF	90	MANRBC	106	231B42	139	231V54/9	137
REHRHG	86	MANS	106	231B42/B	139	231V54/D	137
RERHRH	86	MANT	108	231B44	139	231V62	131
REHRHJ	86	MANU	108	231B52	137	231V62/9	131
REXFUJ	96	MANV	108	231B52/B	137	231V72	132
REXFVJ	96			231B54	137	231V72/9	132
RWRHRH	86	Dyane		231B72	132	231V82	132
RWRHRJ	86	AYA3-A-AM	121	231B72/B	132	231V82/9	132
UCT7714M3081	95	AYB	121	231B82	132	231V82/D	132
		AY-CB	121	231B82/B	132	231V92	138
				231B84	132	231V94	138
		Evasion		231B92	138	231V94/9	138
C6				231BJ2	134	231VH2/D	141
MCT3902U4994	97	AFRFNC	126	231BL2	141	231VJ2/D	134
MCT3912U6061	97	AFRFNF	126	231C22	133	232	141
TDXFVJ	97	AFRFVB	125	231C22/9	133	232A22	133
TDXFVU	97	AFRHZ A	127	231C22/E	133	232A62	131
		AFRHZ A/T	127	231C24	133	232A72	132
C8		MCT000AHL173	122	231C24/9	133	232B22	133
EA3FZC	102	MCT000AHM174	122	231C24/D	133	232B22/1	133
EA4HWB	103	MCT000AHN175	124	231C24/E	133	232B22/1/B	133
EA4HWG	103	MCT000AHP176	129	231C32/D	131	232B22/B	133
EARFNC	98	MCT000AHQ178	123	231C42	139	232B42	139
EARHME	100	MCT000AHR179	130	231C42/9	139	232B42/1	139
EARHTB	100	MCT1306H2226	122	231C44	139	232B42/1B	139
EAXFWF	104	MCT1306H3227	122	231C44/9	139	232B42/B	139
EB3FZC	102	MCT1406HA224	124	231C44/E	139	232B44	139
EB4HWB	103	MCT1506HJ514	125	231C62	131	232B44/1	139
EB4HWG	103	MCT1506HU658	126	231C62/9	131	232B52	137
EBRFJC	99	MCT1506HZ627	126	231C72	132	232B52/1	137
EBRFJF	99	MCT1606HT223	129	231C72/9	132	232B52/1/B	137
EBRFNF	98	MCT3506H1659	126	231C82	132	232B52/B	137
EBRHME	100	MCT3506H6628	126	231C82/9	132	232B54	137
EBRHRH	101	MCT3506HQ515	126	231C82/D	132	232B54/1	137
EBRHTB	100	MCT5206H3225	123	231C82/E	132	232B72	132
EBRHWB	100	MCT5306HF457	127	231C92	138	232B72/1	132
EBXFWF	104	MCT5306HH229	130	231C92/9	138	232B72/B	132
M10CTRVP000H028	101	MCT5306HN562	127	231E72	132	232B82	132
MCT1506N4662	98	MCT5306HP563	127	231G22	133	232B82/1	132
MCT1616NJ011	99	U6UA	129	231G22/2	133	232B82/B	132
MCT1706NP663	102	U6UB	124	231G32	133	232B92	138
MCT1706NQ664	102	U6UB/T	125	231G42	139	232B92/1	138
MCT3506NF764	98	U6UC	123	231G42/2	139	232C32/D	131
MCT3616NH173	99	U6UC/T	123	231G52	137	232C62	131
MCT3616NN010	99	U6UE	122	231G52/2	137	232C62/9	131
MCT3616NP012	99	U6UE/1	122	231G72	132	232C72	132
MCT3806NB730	104	U6UE/1/T	122	231G82	132	232C72/9	132
MCT5306N0666	100	U6UJ	123	231G92	138	232C82/D	132
MCT5306N2668	100	U6UJ/8	123	231H22	133	232E22	133
MCT5506NN669	103	U6UJ/T	123	231H32	133	232E62	132
MCT5506NP670	103	U6UW	130	231H42	139	232E82	132
MCT5506NY838	103	U6UW/T	130	231H52	137	232F22	133
MCT5506NZ839	103	VCT000AH0179	130	231H72	132	232F42	139
MCT5516NR054	101	VCT000AHZ178	123	231H82	132	232F52	137
MCT5516NS055	101	VCT1506HS514	125	231H92	138	232F92	138
MCT7306N8790	100	VCT5206HC225	123	231J42	139	232G22	133
		VCT5306HP457	130	231J52	137	232G22/2	133
		VCT5306HQ229	130	231J92	138	232G42	139
		Jumper		231JL2	141	232G42/2	139
CX				231V22	133	232G52	137
MAMM	107	231A22	133	231V22/9	133	232G52/1	137
MAMN	107	231A22/B	133	231V22/D	133	232G52/2	137
MAMNE	107	231A32	131	231V24	133	232G54	137
MAMP	105	231A32/B	133	231V24/9	133	232G72	132
MAMR	105	231A52	137	231V24/D	133	232G82	132
MAMRE	105	231A62	131	231V42	139	232G92	138
MAN	109	231A62/B	131	231V42/9	139	232H22	133
MANB	108	231A72	131	231V42/D	139	232H22/1	133
MANC	108	231A72/B	132	231V44	139	232H42	139
MAND	108	231A82	132	231V44/9	139	232H44	139
MANG	109	231A84	132	231V44/D	139	232H52	137
MANGA	109	231AJ2	134	231V52	137	232H52/1	137
MANHH	109	231AL2	141	231V52/9	137	232H54	137
MANJ	109	231B12	133				
MANK	110						
MANKC	110						

* C.N.I.T. = Code National d'Identification du Type (code D2.1 sur nouvelles cartes grises)

Type Mines OU C.N.I.T.*	Encadré N°	Type Mines OU C.N.I.T.*	Encadré N°	Type Mines OU C.N.I.T.*	Encadré N°	Type Mines OU C.N.I.T.*	Encadré N°
232H72	132	233B22	133	MCT000AEA226	137	ZBRMP	136
232H82	132	233B42	139	MCT000AEB227	137	ZBTMF	133
232H92	138	233B42/B	139	MCT000AEG232	137	ZBTMP	133
232J12	133	233B44	139	MCT000AEH233	137	ZCMNCA	142
232J22	133	233B52	137	MCT000AEJ137	137	ZCMNCAY	142
232J22/1	133	233B92	138	MCT000AEJ235	137	ZCPMD	141
232J22/B	133	233D22	133	MCT000AEL237	133	ZCPMF	141
232J42	139	233D42	139	MCT000AEM202	137	ZCPMH	141
232J42/1	139	233D52	137	MCT000AEN239	133	ZCPMM	141
232J42/B	139	233D92	138	MCT000AEP204	132	ZCRMMD	136
232J44	139	233F22	133	MCT1303E2465	133	ZCRMFM	136
232J44/1	139	233G22	133	MCT1303EJ481	133	ZCRMHM	136
232J52	137	233G22/1	133	MCT1303EJ482	133	ZCRMMM	136
232J52/1	137	233G42	139	MCT1303EM352	133	ZCTMF	133
232J52/B	137	233G42/1	139	MCT1303EN353	133	ZCTMM	133
232J54	137	233G42/2	139	MCT1306E9272	133		
232J54/1	137	233G52	137	MCT1306EA298	133	Jumpy	
232J92	138	233G52/1	137	MCT1403EG688	133	BADHXA	147
232K22	133	233G52/2	137	MCT1403EJ691	133	BARFNC	148
232K42	139	233G92	138	MCT5203E0655	134	BARFNF	148
232K42/2	139	233G92/1	138	MCT5203E1656	134	BARHWP	149
232K44	139	233H22	133	MCT5203E3489	137	BARHXA	152
232K44/2	139	233H22/1	133	MCT5203E5782	134	BARHZA	149
232K52	137	233H42	139	MCT5203E7784	134	BARHZB	149
232K52/2	137	233H42/1	139	MCT5203EA471	137	BAWJZA	146
232K54	137	233H52	137	MCT5203ED341	132	BBDHXA	147
232K54/2	137	233H52/1	137	MCT5203EF476	137	BBRFNC	148
232K92	138	233H92	138	MCT5203EF695	134	BBRHXB	152
232K94	139	233H92/1	138	MCT5203EG696	134	BBRHZA	149
232K94/2	139	233J22	133	MCT5203EH697	134	BBRHZB	149
232L22	133	233J22/B	133	MCT5203EV359	137	BBWJZA	146
232L22/1	133	233J42	139	MCT5203EW360	137	BCHRZB	150
232L42	139	233J42/B	139	MCT5203EX361	137	BDRFNC	148
232L52	137	233J44	139	MCT5203EY653	134	BDRFNF	148
232L52/1	137	233J52	137	MCT5206EJ280	137	BDRHXB	152
232L54	137	233J52/B	137	MCT5206EK306	137	BDRHZA	149
232L92	138	233J54	137	MCT5303E0742	136	BDRHZB	150
232N22	133	233J92	138	MCT5303E1743	136	BDWJYB	146
232N42	139	233J94	138	MCT5303EA486	139	BDWJZA	146
232N44	139	233K22	133	MCT5303EB487	139	BEDHXA	147
232N52	137	233K22/1	133	MCT5303ES698	136	BERFNC	148
232N54	137	233K42	139	MCT5303ET699	136	BERHXA	152
232N92	138	233K42/1	139	MCT5303EV701	136	BERHXB	152
232N94	139	233K42/2	139	MCT5303EW702	136	BERHZA	149
232V22	133	233K44	139	MCT5303EX739	136	BERHZB	149
232V22/9	133	233K44/2	139	MCT5303EY740	136	BEWJZA	146
232V22/D	133	233K52	137	MCT5503E6570	141	BHRHZA	149
232V22/G	133	233K52/1	137	MCT5503E9573	141	BSDHXA	147
232V22/H	133	233K52/2	137	MCT5503EA574	141	BSRHXA	152
232V24	133	233K54	137	MCT5503EB575	141	BSRHXB	152
232V24/9	133	233K54/1	137	MCT5503EC576	141	BSRHZB	149
232V24/D	133	233K54/2	137	MCT5503EH703	141	BTRHWP	150
232V42	139	233K92	138	MCT5503EJ704	141	BTWJYB	146
232V42/9	139	233K92/1	138	MCT5503EK706	141	BTWJZA	146
232V42/D	139	233K92/2	138	MCT5503EL707	141	BUDHXA	147
232V42/G	139	233K94	139	MCT5503EM708	141	BVWJZA	146
232V42/H	139	233L22	133	VCT5203E6361	137	BWDHXA	147
232V44	139	233L22/1	133	VCT5303EW474	138	BWRHXB	152
232V44/9	139	233L42	139	ZAAMF	134	BXWJZA	146
232V44/D	139	233L42/1	139	ZAAMP	134	BYDHXA	147
232V52	137	233L52	137	ZAPMF	141	BYRHWP	149
232V52/9	137	233L52/1	137	ZAPMP	141	BYRHXA	152
232V52/D	137	233L54/1	137	ZARMF	136	BYRHXB	152
232V52/G	137	233L92	138	ZARMP	136	BYRHZB	149
232V52/H	137	233L92/1	138	ZATMF	133	BZDHXA	147
232V52G	137	233N22	133	ZBAMD	134	BZRFNC	153
232V54	137	233N42	139	ZBAMF	134	BZRHWP	150
232V54/9	137	233N44	139	ZBAMP	134	BZRHXA	152
232V54/D	137	233N52	137	ZBPMD	141	BZRHXB	152
232V82	132	233N54	137	ZBPMF	141	BZWJYB	146
232V82/9	132	233N92	138	ZBPMH	141	BZWJZA	146
232V82/D	132	233N94	139	ZBPMP	141	M10CTRV0000108	151
232V92	138	MCT000AE8127	133	ZBRMD	136	M10CTRV00009117	151
232V94	138	MCT000AE9225	137	ZBRMF	136	M10CTRV0000A118	151
232V94/9	138	MCT000AEA129	132	ZBRMH	136	M10CTRV0000E122	151

* C.N.I.T. = Code National d'Identification du Type (code D2.1 sur nouvelles cartes grises)

Type Mines OU C.N.I.T.*	Encadré N°	Type Mines OU C.N.I.T.*	Encadré N°	Type Mines OU C.N.I.T.*	Encadré N°	Type Mines OU C.N.I.T.*	Encadré N°
M10CTRV000F123	151	U6US/5	147	MCT1001BK509	170	SOKFXF	172
M10CTRV000J127	151	U6US/6	147	MCT1001BL607	170	SOKFXF/IF	172
M10CTRV000K128	151	U6US/8	147	MCT1002B3041	169	SOKFXG	172
M10CTRV000P133	151	U6US/9	147	MCT1002B4042	169	SOKFXT	172
M10CTRV000R134	151	U6UT	144	MCT1002B5043	170	SONFZF	174
M10CTRV000Z107	151	U6UT/5	144	MCT1002B7045	170	SOVJXB	173
MCT000AJ0186	147	U6UT/6	144	MCT1002B8046	169	SOVJYF	173
MCT000AJ1187	147	U6UT/8	144	MCT1002BC729	170	SOVJZC	173
MCT000AJ2188	147	U6UT/9	144	MCT1002BF405	169	SOVJZC/T	173
MCT000AJ3189	147	U6UU	145	MCT1002BJ408	170	SOVJZE	173
MCT000AJJ459	147	U6UU/9	145	MCT1002BJ480	170	SOVJZE/T	173
MCT000AJJ460	145	VCT000AJB188	145	MCT1002BK507	169	SOVJZF	173
MCT000AJU180	144	XARHKH	151	MCT1002BN510	170	SOVJZF/T	173
MCT000AJV181	144	XARHRH	151	MCT1002BP608	170	S1CDYF	169
MCT000AJW182	144	XCRHKH	151	MCT1101BF433	172	S1CDZE	169
MCT000AJX183	144	XCRHRH	151	MCT1101BH496	172	S1CDZF	169
MCT000AJY184	145	XDRHKH	151	MCT1101BR021	172	S1HDYF	171
MCT000AJZ185	145	XDRHRH	151	MCT1101BT023	172	S1HDZC	170
MCT1103JP236	144	XSRHKH	151	MCT1101BV025	172	S1HDZE	170
MCT1103JP237	144	XTRHKH	151	MCT1101BW026	172	S1HDZF	170
MCT1103JQ238	144	XTRHRH	151	MCT1101BW511	172	S1HDZF/GPL	170
MCT1103JR239	144	XURHKH	151	MCT1101BX512	172	S1HDZG	170
MCT1103JS398	144	XVRHKH	151	MCT1101BY028	172	S1HDZW	170
MCT1103JT399	144			MCT1102B0513	172	S1HFXB	170
MCT1103JU400	144	LNA		MCT1102BK048	172	S1KFWL	172
MCT1103JV401	144	RBRD	154	MCT1102BM050	172	S1KFXD	172
MCT1503JD803	153	RBRE	154	MCT1102BV411	172	S1KFXF	172
MCT1503JE804	153	RBRF	154	MCT1201BB031	174	S1KFXF/IF	172
MCT1503JG806	153	RBRG	156	MCT1201BE034	174	S1KFXG	172
MCT1503JH807	153	RBRH	155	MCT1301B5536	174	S1KFXT	172
MCT1503JJ517	153	RBRJ	156	MCT1401BZ035	175	S1NFZF	174
MCT5103J5241	145	RBRK	156	MCT3101B0024	172	S1VJXB	173
MCT5103JA246	146	RBRKA	156	MCT3101B3027	172	S1VJYF	173
MCT5103JC248	145			MCT3102B0410	172	S1VJZC	173
MCT5203J4230	147	Mehari		MCT3102BR049	172	S1VJZE	173
MCT5203J5231	147	AYCA	157	MCT3102BT597	172	S1VJZF	173
MCT5203J6232	147	AYCE	157	MCT3102BU052	172	S3CDZF	169
MCT5203J7233	147			MCT5001B8036	173	S3HDZF	170
MCT5203J8234	147	Nemo		MCT5001BA038	173	S3HFXB	170
MCT5203J9235	147	AAKFCV	158	MCT5001BB039	173	S3VJXB	173
MCT5203JA818	152	MCT1112XA281	158	MCT5001BC040	173	S3VJZF/T	173
MCT5203JB819	152			MCT5001BL534	173	S6HDZC	170
MCT5203JD821	152	Saxo		MCT5001BT675	173	S6HDZF	170
MCT5203JE822	152	MCT000AB6067	175	MCT5002B0414	173	S6KFWB	172
MCT5203JJ245	147	MCT000AB6455	170	MCT5002B1415	173	S6NFTB	174
MCT5203JL247	147	MCT000AB8069	169	MCT5002BM436	173	S6NFXF	175
MCT5303J0543	149	MCT000ABB194	172	MCT5002BP535	173	S6NFZF	174
MCT5303J1544	149	MCT000ABC195	172	MCT5002BV057	173	VCT000ABT081	173
MCT5303JH815	149	MCT000ABD038	175	MCT5002BW058	173	VCT1001BH012	169
MCT5303JJ816	149	MCT000ABD196	172	MCT5002BX059	173	VCT1001BL016	170
MCT5303JJ817	149	MCT000ABE075	170	MCT5002BY060	173	VCT1001BQ506	169
MCT5303JP823	149	MCT000ABE197	172	MCTZ001BT016	170	VCT1001BT509	170
MCT5303JQ824	149	MCT000ABF040	169	MCTZ002BP045	170	VCT5001BJ038	173
MCT5303JS826	149	MCT000ABG041	169	MCTZ002BZ408	170	VCT5001BK039	173
MCT5303JT827	149	MCT000ABH078	172	S0CDYF	169	VCTZ001B2016	170
MCT5413J4184	151	MCT000ABJ044	170	S0CDZE	169		
MCT5413J8188	151	MCT000ABJ079	173	S0CDZE/T	169	Visa	
MCT5413JW079	151	MCT000ABK081	173	S0CDZF	169	VDPC	186
MCT5414JM128	151	MCT000ABL046	170	S0CDZF/T	169	VDPD	190
MCT5513JF185	151	MCT000ABM047	172	S0HDYF	171	VDPE	188
MCT5513JJ189	151	MCT000ABM083	173	S0HDZC	170	VDPEA	188
U6KS	147	MCT000ABP050	174	S0HDZC/GPL	170	VDVA	185
U6KU	147	MCT000ABP304	172	S0HDZC/T	170	VDVB	187
U6KU/R	147	MCT000ABP305	172	S0HDZC/TGPL	170	VDVBG	187
U6UF	145	MCT000ABQ051	173	S0HDZE	170	VDVF	185
U6UG	144	MCT000ABS053	173	S0HDZE/T	170	VDVG	187
U6UH	147	MCT000ABU055	173	S0HDZF	170	VDVGB	187
U6UK	147	MCT1001B8012	169	S0HDZF/GPL	170	VDVGD	187
U6UL	147	MCT1001B9013	169	S0HDZF/T	170	VDVGE	187
U6UN	144	MCT1001B9728	170	S0HDZF/TGPL	170	VDVJ	185
U6UN/R	144	MCT1001BA014	170	S0HDZG	170	VDVK	187
U6UP	145	MCT1001BB015	170	S0HDZW	170	VDVKB	187
U6UR	147	MCT1001BC016	170	S0HFXB	170	VDVR	188
U6UR/8	147	MCT1001BE018	170	SOKFWB	172	VDVRB	188
U6UR/9	147	MCT1001BH506	169	SOKFXD	172	VDVS	188

* C.N.I.T. = Code National d'Identification du Type (code D2.1 sur nouvelles cartes grises)

Type Mines OU C.N.I.T.*	Encadré N°	Type Mines OU C.N.I.T.*	Encadré N°	Type Mines OU C.N.I.T.*	Encadré N°	Type Mines OU C.N.I.T.*	Encadré N°
VDVT	191	MCT000AAY024	193	MCT7202AH442	198	X1LFYM	195
VDVTA	191	MCT000AAY060	204	MCT7202AJ188	198	X1P8CF	204
VDVTE	191	MCT000AAY157	197	MCT7204AL187	198	X1RFVF	202
Xantia		MCT000AAY315	202	MCT7204AM443	198	X1RFVF/D3	202
MCT000AA0123	204	MCT000AAY412	198	MCT7204AN189	198	X1RFVG	202
MCT000AA0317	203	MCT000AAY448	198	VCT000AA6447	198	X1RFVU	202
MCT000AA0414	198	MCT000AAZ025	193	VCT000AAH325	198	X1RFXM	200
MCT000AA1124	204	MCT000AAZ061	204	VCT000AAL002	198	X1RGXF	203
MCT000AA1318	205	MCT000AAZ122	201	VCT5204AL184	198	X1RHYF	199
MCT000AA1415	198	MCT000AAZ316	201	VCT5204AR445	198	X1RHZB	199
MCT000AA2125	198	MCT000AAZ413	198	X11A	193	X1RHZF	199
MCT000AA2319	205	MCT1202AN078	194	X11D	203	X1XFZM	205
MCT000AA2416	195	MCT1202AU376	192	X11E	193	X2DHWF	197
MCT000AA3417	195	MCT1202AV377	194	X11EA	193	X2DHFV	198
MCT000AA4321	205	MCT1202AZ151	194	X11F	203	X2DHXF/T	198
MCT000AA4418	195	MCT1204AA152	194	X11G	204	X2DHXM	198
MCT000AA5322	197	MCT1402A2389	195	X12A	193	X2LFXF	194
MCT000AA5419	195	MCT1402A3390	195	X12B	192	X2LFYB/IF	195
MCT000AA6323	197	MCT1402A5004	195	X12D	197	X2LFYC	195
MCT000AA6420	195	MCT1402A7394	195	X12E	193	X2LFYC/GPL	195
MCT000AA7324	198	MCT1402AL153	195	X12EA	193	X2LFYF	195
MCT000AA7421	195	MCT1402AM154	195	X12F	194	X2P8CF	204
MCT000AA8325	198	MCT1402AQ158	195	X12G	204	X2RFVF	202
MCT000AA9326	204	MCT1402AR159	195	X12H	195	X2RFVM	202
MCT000AA9362	204	MCT1402AS160	195	X13A	196	X2RFXM	200
MCT000AA9423	195	MCT1402AU417	195	X13C	196	X2RGXF	203
MCT000AAA036	204	MCT1404A0164	195	X13E	202	X2RHYE	199
MCT000AAA169	195	MCT1404A5194	195	X13EA	202	X2RHYF/T	199
MCT000AAA327	204	MCT1404A9392	195	X13G	204	X2RHZF	199
MCT000AAAB037	204	MCT1404AA393	195	X13H	195	X2XFZF	205
MCT000AAAB170	195	MCT1404AS156	195	X13L	196	X2XFZM	205
MCT000AAAB328	204	MCT1404AT157	195	X14A	200	X7P8CF	204
MCT000AAC002	198	MCT1404AT581	195	X14B	200	X7RFVF	202
MCT000AAC171	195	MCT1502AA168	202	X14C	195	X7RGXF	203
MCT000AAC329	192	MCT1502AD171	202	X14D	205	X7RHZF	199
MCT000AAD003	198	MCT1504AF169	202	X14F	201	X7XFZF	205
MCT000AAD172	193	MCT1602AS176	201	X14G	204	XM	
MCT000AAD330	194	MCT1604AV175	203	X14H	197	MCT000AF0154	215
MCT000AAE004	203	MCT1802A9076	205	X15A	201	MCT000AF2156	215
MCT000AAE331	195	MCT1802AG180	205	X15C	195	MCT000AFB262	213
MCT000AAF005	203	MCT1802AM380	205	X15D	205	MCT000AFC263	213
MCT000AAG006	200	MCT1804AJ178	205	X15E	200	MCT000AFD264	213
MCT000AAH007	200	MCT3402AA391	195	X15EA	200	MCT000AFE265	213
MCT000AAM084	205	MCT3402AT155	195	X15F	201	MCT000AFG267	213
MCT000AAP306	195	MCT3402AZ161	195	X15G	204	MCT000AFK138	209
MCT000AAQ307	195	MCT3502AK172	200	X16A	196	MCT000AFL139	209
MCT000AAQ440	202	MCT3504AP173	202	X16C	195	MCT000AFM140	209
MCT000AAR114	200	MCT3802AJ177	205	X16D	203	MCT000AFN141	209
MCT000AAR308	193	MCT3802AT381	205	X16E	203	MCT000AFP143	210
MCT000AAS090	205	MCT3804AP179	205	X16EA	203	MCT000AFQ144	209
MCT000AAS115	192	MCT5102A2382	197	X16G	195	MCT000AFR145	210
MCT000AAS309	195	MCT5102AV181	197	X17A	193	MCT000AFS146	210
MCT000AAS442	200	MCT5104A0182	197	X17B	200	MCT000AFT147	214
MCT000AAT091	205	MCT5104AF222	197	X17E	198	MCT000AFU148	213
MCT000AAT116	198	MCT5202A7183	198	X17E/T	198	MCT000AFV149	213
MCT000AAT310	195	MCT5202A9185	198	X17F	198	MCT000AFW150	213
MCT000AAT443	202	MCT5202AD444	199	X17T/F	198	MCT000AFX151	213
MCT000AAU020	202	MCT5202AW585	199	X18A	198	MCT000AFY152	214
MCT000AAU056	202	MCT5204A1586	199	X18AAPP	198	MCT000AFZ153	216
MCT000AAU311	200	MCT5204AC184	198	X18D	204	MCT1502FJ197	209
MCT000AAU444	202	MCT5204AJ445	199	X18E	198	MCT1502FL199	209
MCT000AAV021	201	MCT5204AZ002	198	X19B	193	MCT1504F0210	209
MCT000AAV057	202	MCT5302AH402	199	X19C	202	MCT1602FW200	210
MCT000AAV118	195	MCT5302AJ403	199	X19E	202	MCT1604FC212	210
MCT000AAV312	202	MCT5302AN383	204	X1BFZF	192	MCT1802FJ202	215
MCT000AAV445	198	MCT5302AP190	204	X1DHWF	197	MCT3502FQ198	209
MCT000AAW022	193	MCT5302AP384	204	X1DHXF	198	MCT3602F3201	210
MCT000AAW058	203	MCT5302AQ192	204	X1DHXM	198	MCT3802FP203	216
MCT000AAW119	202	MCT5302AX454	199	X1L6AG	193	MCT3804F5215	216
MCT000AAW313	202	MCT5302AY455	199	X1LFXF	194	MCT5302FJ204	213
MCT000AAW446	198	MCT5304A3456	199	X1LFYB/IF	195	MCT5302FK206	213
MCT000AAX023	193	MCT5304AK340	204	X1LFYC	195	MCT5304F1219	213
MCT000AAX059	203	MCT5304AN404	199	X1LFYC/GPL	195	MCT5304FZ217	213
MCT000AAX447	198	MCT5304AT191	204	X1LFYF	195	MCT5502F7209	214
		MCT7202AG186	198				

* C.N.I.T. = Code National d'Identification du Type (code D2.1 sur nouvelles cartes grises)

Type Mines OU C.N.I.T.*	Encadré N°	Type Mines OU C.N.I.T.*	Encadré N°	Type Mines OU C.N.I.T.*	Encadré N°	Type Mines OU C.N.I.T.*	Encadré N°
MCT5504FN221	214	CHRHYA	236	MCT1406L6676	229	N08HZB	217
MCT7302FP205	213	CHRHYB	236	MCT1406LY499	229	N08HZB/T	217
MCT7302FR207	213	MCT000AG0286	226	MCT1501GH559	235	NOA9AF/T	224
MCT7304F4216	213	MCT000AG4290	226	MCT1502G3385	234	N0DHYF	233
MCT7304F6218	213	MCT000AG5158	220	MCT1502GK560	235	N0DJYF	231
Y3AA	206	MCT000AG6159	225	MCT1504G9387	234	N0KFWB	218
Y3AB	206	MCT000AG7160	218	MCT1504GP561	235	N0KFWB/IF	218
Y3AC	207	MCT000AG8161	231	MCT1701GP546	234	N0KFWB/T	218
Y3ACA	207	MCT000AG9162	233	MCT1701GX131	234	N0KFXB	218
Y3AD	215	MCT000AGB164	227	MCT3202GG447	220	N0KFXF	218
Y3AE	211	MCT000AGC165	226	MCT3301G6587	221	N0KFXF/GPL	218
Y3AF	212	MCT000AGH292	220	MCT3301GJ115	227	N0KFXF/T	218
Y3AH	207	MCT000AGJ268	234	MCT3302G9588	221	N0KFXF/T/GPL	218
Y3AHA	207	MCT000AGJ294	225	MCT3302GK114	227	N0KFXG	218
Y3AJ	206	MCT000AGK295	225	MCT3302GM116	227	N0LFXF	225
Y3AK	212	MCT000AGL271	227	MCT3302GS643	221	N0LFYF	226
Y3AL	215	MCT000AGL296	225	MCT3304GE589	221	N0LFYF/GPL	226
Y3AP	207	MCT000AGM272	227	MCT3304GR117	227	N0LFZM	227
Y3AR	207	MCT000AGN273	227	MCT3501GC609	235	NONFUB	221
Y3ARA	207	MCT000AGN431	218	MCT3501GM716	235	NONFUN	221
Y3AS	211	MCT000AGP274	231	MCT3502GA386	234	NONFZF	220
Y3AT	212	MCT000AGP275	230	MCT3502GF610	235	NORFN1	235
Y3ATA	212	MCT000AGP299	218	MCT3502GP177	235	NORFN1/IF	235
Y3AW	215	MCT000AGP300	218	MCT3504GK611	235	NORFNB	235
Y3AWA	215	MCT000AGP432	218	MCT3504GR388	234	NORFNN	235
Y3AX	210	MCT000AGP433	218	MCT3504GU718	235	NORFSB	234
Y3AXA	210	MCT000AGQ276	230	MCT3506LJ770	235	NORHYB	236
Y3AY	210	MCT000AGQ301	218	MCT3516LN022	235	NORHYB/T	236
Y3AYA	210	MCT000AGR277	233	MCT5001GH137	230	NORHYF	236
Y3AZ	207	MCT000AGS278	233	MCT5001GR765	217	NORHZB	236
Y3CM	215	MCT000AGT279	233	MCT5002GE132	231	NORHZN	236
Y3CN	215	MCT000AGV281	233	MCT5002GJ136	231	NOWJYB	230
Y3CNA	215	MCT000AGW282	226	MCT5002GK138	231	NOWJYB/T	230
Y3CU	215	MCT000AGY284	226	MCT5002GU766	217	NOWJZF	230
Y4CW	213	MCT1101G7553	218	MCT5004GP139	230	NOWJZF/T	230
Y4CZ	209	MCT1101GC098	218	MCT5004GZ767	217	N18HZB	217
Y4GB	209	MCT1101GF101	218	MCT5101GD547	230	N18HZB/T	217
Y4GG	210	MCT1101GS599	218	MCT5101GX373	230	N1DHVB	232
Y4GM	210	MCT1102GA554	218	MCT5102G0374	230	N1DHYF	233
Y4GN	215	MCT1102GD097	218	MCT5102GG548	230	N1DHYF/T	233
Y4GR	215	MCT1102GJ102	218	MCT5104G5375	230	N1DJYF	231
Y4GU	215	MCT1102GJ103	218	MCT5104GL549	230	N1DJYF/T	231
Y4GW	211	MCT1102GV600	218	MCT5201G9145	233	N1KFWB	218
Y4GX	213	MCT1104GF555	218	MCT5201GA437	236	N1KFWB/IF	218
Y4GY	213	MCT1104GJ099	218	MCT5201GB438	236	N1KFXB/IF	218
Y4GZ	213	MCT1104GP104	218	MCT5201GC148	233	N1KFXF	218
Y4MZ	213	MCT1104GP105	218	MCT5201GK799	233	N1KFXF/GPL	218
Y4NW	213	MCT1201GV107	220	MCT5201GM449	236	N1KFXG	218
Y4NX	214	MCT1201GZ111	225	MCT5201GN450	236	N1LFXF	225
Y4NY	214	MCT1202G0110	225	MCT5201GQ550	236	N1LFYF	226
Y4RM	214	MCT1202G2112	225	MCT5202G9143	233	N1LFYF/GPL	226
Y4RN	213	MCT1202GW106	220	MCT5202GC146	233	N1LFZM	227
Y4TD	213	MCT1202GY108	220	MCT5202GE439	236	N1LFZU	227
Y4TN	215	MCT1204G3109	220	MCT5202GF149	233	N1NFUB	221
Y4TR	215	MCT1204G7113	225	MCT5202GN800	236	N1NFUN	221
Y4TS	210	MCT1206LD498	220	MCT5202GQ451	233	N1NFZ	220
Y4TT	210	MCT1206LN508	220	MCT5202GT551	233	N1NFZF	220
Y4TU	209	MCT1206LT744	220	MCT5204GH147	233	N1NFZG	220
Y4TV	209	MCT1301GU556	221	MCT5204GK441	233	N1RFN1	235
Y4TX	209	MCT1301GW619	221	MCT5204GS801	236	N1RFN1/IF	235
Y4WG	216	MCT1302GX557	221	MCT5204GW453	236	N1RFNB	235
Y4WH	216	MCT1302GZ620	221	MCT5204GY552	236	N1RFNN	235
Y4WK	216	MCT1304G2558	221	MCT5206LR500	236	N1RFV	234
		MCT1304G4621	221	MCT5206LS501	236	N1RFVM	234
		MCT1316L6031	221	MCT5216LR377	222	N1RHVB	236
		MCT1316LW021	221	MCT5216LX020	222	N1RHYB/T	236
CH6FZB	229	MCT1401G0128	226	MCT5301GP636	236	N1RHYF	236
CH6FZC/IF	229	MCT1401GU122	226	MCT5302GT638	236	N1RHZB	236
CH9HXC	222	MCT1401GV123	226	MCT5304GZ640	236	N1RHZN	236
CH9HYB	223	MCT1401GZ127	226	MCT5306L8663	223	N1VJZF	219
CH9HZC	223	MCT1402G4130	226	MCT5306LE840	223	N1WJYB	230
CHNFU	221	MCT1402GT119	226	MCT5306LN849	223	N1WJYB/T	230
CHNFVB	220	MCT1402GZ125	226	MCT7301GW637	236	N1WJZF	230
CHNFVK	220	MCT1404G4126	226	MCT7302G0639	236	N1WJZF/T	230
CHNFZA	220	MCT1406L0537	229	MCT7304G6641	236	N28HZB	217
CHRFNE	235						

* C.N.I.T. = Code National d'Identification du Type (code D2.1 sur nouvelles cartes grises)

Type Mines OU C.N.I.T.*	Encadré N°	Type Mines OU C.N.I.T.*	Encadré N°	Type Mines OU C.N.I.T.*	Encadré N°	Type Mines OU C.N.I.T.*	Encadré N°
N28HZB/T	217	N2B5	246				
N2A9AF	224	N2B8	251				
N2A9AF/T	224	N2B8A	251				
N2DHVB	232	N2C2/T	247				
N2DHWB	232	N2C3	250				
N2DHYF	233	N2C3A	250				
N2DJYF	231	N2C4	250				
N2KFWB	218	N2C4/T	250				
N2KFWB/IF	218	N2C4T	250				
N2KFWB/T	218	N2C5	250				
N2KFXB	218	N2C6	250				
N2KFXF	218	N2C7	252				
N2KFXF/GPL	218	N2C8	252				
N2KFXF/T	218	N2C9	238				
N2KFXF/T/GPL	218	N2D5	250				
N2LFXF	225	N2D5/T	250				
N2LFYF	226	N2D7	243				
N2LFYF/GPL	226	N2D8	250				
N2LFZM	227	N2D9	252				
N2NFUB	221	N2E1	243				
N2NFUN	221	N2E1/T	243				
N2NFZF	220	N2E3	248				
N2RFN1	235	N2E3A	248				
N2RFN1/IF	235	N2E4	248				
N2RFNB	235	N2E4A	248				
N2RFNN	235	N2E6	253				
N2RFVF	234	N2E7	253				
N2RFVM	234	N2E8	253				
N2RHYB	236	N2E9	243				
N2RHYB/T	236	N2F1	254				
N2RHYF	236	N2F2	248				
N2RHZB	236	N2F5	252				
N2RHZN	236	N2G1	246				
N2VJZF	219	N2G1A	246				
N2WJYB	230	N2G2	246				
N2WJYB/T	230	N2H4	248				
N2WJZF	230	N2H5	250				
N2WJZF/T	230	N2H8	250				
N3WJZF	230	N2H8/T	250				
N6DHYF	233	N2H9	250				
N6LFYF	226	N2J1	250				
N6RFSF	234	N2J1/T	250				
N6RHYB	236	N2J3	253				
N6RHYF	236	N2J9	254				
UCT5216LX020	222	N2K5	249				
VCT000AG0277	230	N2K7	249				
VCT000AG2279	231	N2L1	255				
VCT000AGJ162	231	N2L2	237				
VCT000AGX274	230	N2L2/T	237				
VCT000AGX299	218	N2L3	237				
VCT000AGY275	231	N2L5	250				
VCT5002GR136	231	N2L6	250				
VCT5002GT138	231	N2L7	243				
VCT5101G6373	230	N2L9	243				
		N2M1	243				
ZX							
MCT000ADJ103	250						
MCT000ADL105	243						
MCT000ADM106	246						
MCT000ADQ110	250						
MCT000ADS112	252						
MCT1101DH081	243						
MCT1401DE084	249						
MCT5004D2094	250						
N2	249						
N2A1	238						
N2A3	237						
N2A4	237						
N2A4/T	237						
N2A7	239						
N2A9	243						
N2B1	243						
N2B2	246						
N2B4	246						
N2B4A	246						



* C.N.I.T. = Code National d'Identification du Type (code D2.1 sur nouvelles cartes grises)

IDENTIFICATION JOINTS DE CULASSE - Moteur Diesel CYLINDER HEAD GASKET IDENTIFICATION - Diesel Engine PEUGEOT - CITROËN - Moteur XUD7 Atmo / XUD7 N.A. Engine

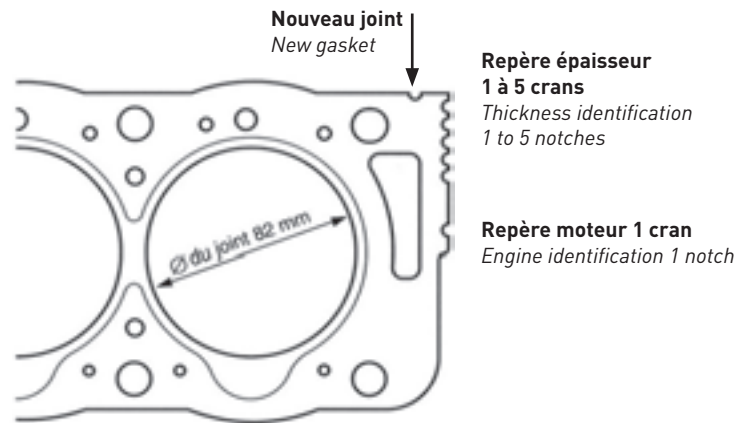
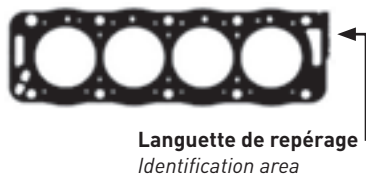



Moteurs / Engines XUD7 Atmo / N.A. → Alésage / Bore = 80 mm - 1769 cm³



ANCIENS JOINTS FIBREUX (3 épaisseurs différentes) OLD FIBER GASKETS (3 different thicknesses)

	} 1 Cran / Notch
	} 2 Crans / Notches
	} 3 Crans / Notches

NOUVEAUX JOINTS FIBREUX (5 épaisseurs différentes) NEW FIBER GASKETS (5 different thicknesses)

	} 1 Cran / Notch	BX 830 Ép. / Thick. = 1,36 mm*
	} 2 Crans / Notches	BX 840 Ép. / Thick. = 1,40 mm*
	} 3 Crans / Notches	BX 850 Ép. / Thick. = 1,44 mm*
	} 4 Crans / Notches	BX 860 Ép. / Thick. = 1,48 mm*
	} 5 Crans / Notches	BX 870 Ép. / Thick. = 1,52 mm*

* L'épaisseur correspond à l'épaisseur serrée sur moteur.
* The above thickness refers to the assembled thickness.



Attention: mesurer systématiquement les dépassements de pistons au PMH pour déterminer le joint de culasse d'épaisseur optimale (voir les notes techniques en fin de catalogue pour identifier la correspondance entre le dépassement du piston et la réf. de joint).

Warning: it is strongly recommended that the gasket selection be made after measuring the UDC piston protrusion; see the technical notes at the end of the catalogue to have the link between the piston protrusion and the gasket part number.

IDENTIFICATION JOINTS DE CULASSE - Moteur Diesel CYLINDER HEAD GASKET IDENTIFICATION - Diesel Engine PEUGEOT - CITROËN - Moteur XUD7 Turbo / XUD7 T.C. Engine

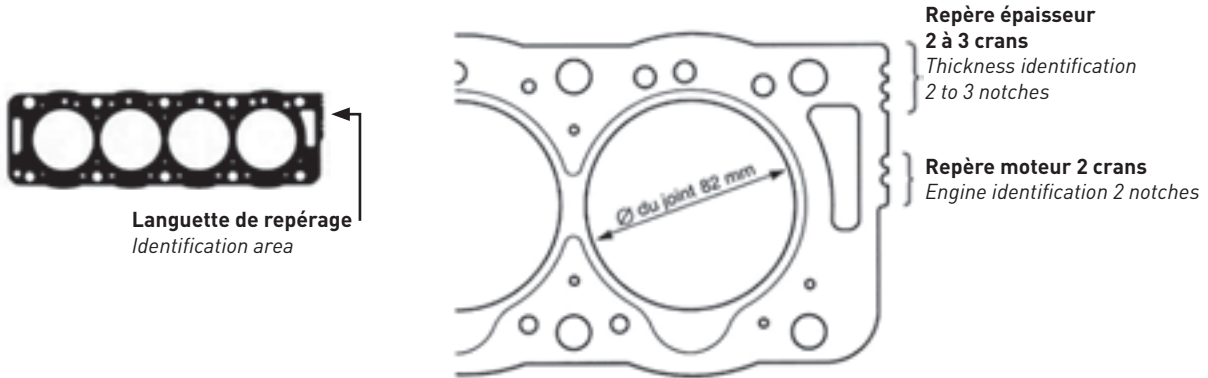
Moteurs / Engines XUD7 Turbo / T.C. → Alésage / Bore = 80 mm - 1769 cm³



 } 2 Crans / Notches	 } 3 Crans / Notches
BX 780 Ép. / Thick. = 1,65 mm*	BX 790 Ép. / Thick. = 1,80 mm*
<p>* L'épaisseur indiquée correspond à l'épaisseur libre (avant montage). * The above thickness refers to the thickness before the assembly of the engine.</p>	

Attention: mesurer systématiquement les dépassements de pistons au PMH pour déterminer le joint de culasse d'épaisseur optimale (voir les notes techniques en fin de catalogue pour identifier la correspondance entre le dépassement du piston et la réf. de joint).

Warning: it is strongly recommended that the gasket selection be made after measuring the UDC piston protrusion; see the technical notes at the end of the catalogue to have the link between the piston protrusion and the gasket part number.

IDENTIFICATION JOINTS DE CULASSE - Moteur Diesel CYLINDER HEAD GASKET IDENTIFICATION - Diesel Engine PEUGEOT - CITROËN - Moteur XUD9 Atmo / XUD9 N.A. Engine

Moteurs / Engines XUD9 Atmo / N.A. → Alésage / Bore = 83 mm - 1905 cm³

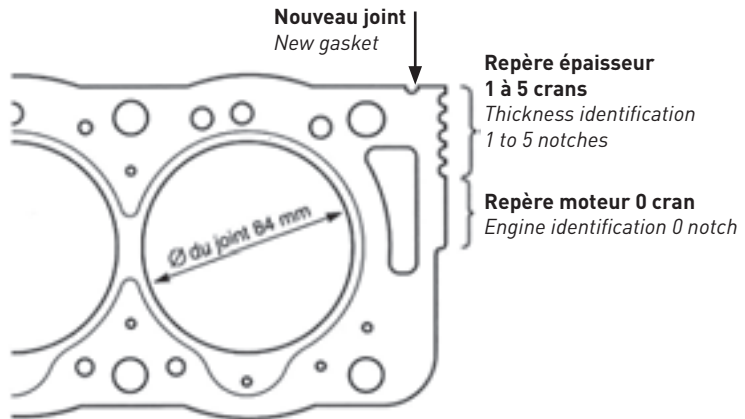
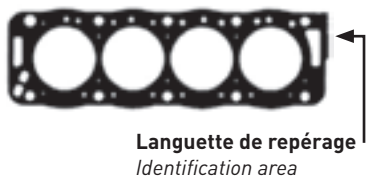



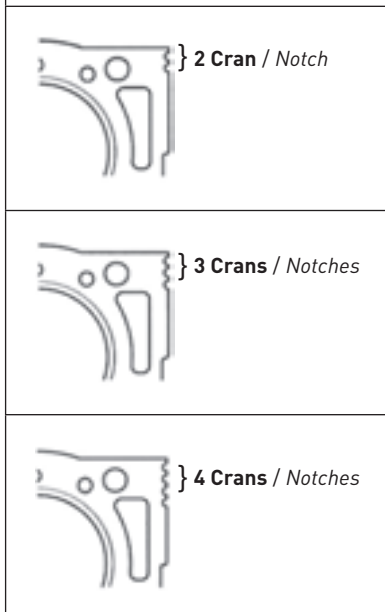

**ANCIENS JOINTS FIBREUX
(3 épaisseurs différentes)
OLD FIBER GASKETS
(3 different thicknesses)**



Ces joints ne sont plus disponibles.
The gaskets are deleted.

**NOUVEAUX JOINTS FIBREUX (5 épaisseurs différentes)
NEW FIBER GASKETS (5 different thicknesses)**

 } 1 Cran / Notch	BX 880 Ép. / Thick. = 1,36 mm*
 } 2 Crans / Notches	BX 890 Ép. / Thick. = 1,40 mm*
 } 3 Crans / Notches	BX 900 Ép. / Thick. = 1,44 mm*
 } 4 Crans / Notches	BX 910 Ép. / Thick. = 1,48 mm*
 } 5 Crans / Notches	BX 920 Ép. / Thick. = 1,52 mm*

* L'épaisseur correspond à l'épaisseur serrée sur moteur.
* The above thickness refers to the assembled thickness.

Attention: mesurer systématiquement les dépassements de pistons au PMH pour déterminer le joint de culasse d'épaisseur optimale (voir les notes techniques en fin de catalogue pour identifier la correspondance entre le dépassement du piston et la réf. de joint).

Warning: it is strongly recommended that the gasket selection be made after measuring the UDC piston protrusion; see the technical notes at the end of the catalogue to have the link between the piston protrusion and the gasket part number.

IDENTIFICATION JOINTS DE CULASSE - Moteur Diesel CYLINDER HEAD GASKET IDENTIFICATION - Diesel Engine PEUGEOT - CITROËN - Moteur XUD9 Turbo / XUD9 T.C. Engine

Moteurs / Engines XUD9 Turbo / T.C. → Alésage / Bore = 83 mm - 1905 cm³

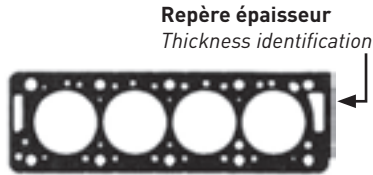



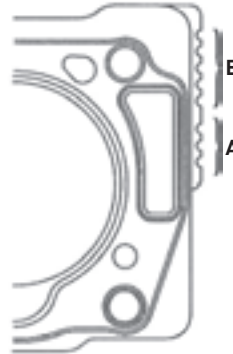

Joint métal-élastomère PAYEN
Steel elastomer gasket PAYEN
A = Repère moteur = 3 crans
A = Engine identification = 3 notches
B = Repère épaisseur = 1 à 5 crans
B = Thickness identification = 1 to 5 notches

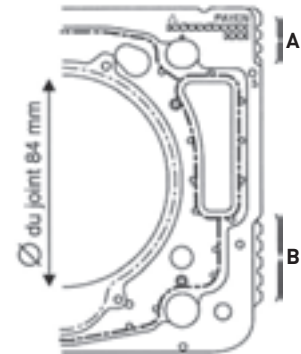





Joint métallique multifeuille
Multi-layer steel gasket
(ELRING)

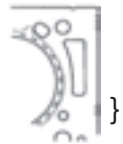

Joint métal-élastomère
Steel elastomer gasket
PAYEN

ANCIENS JOINTS FIBREUX OLD FIBER GASKETS	
 } 1 Cran / Notch	
 } 2 Crans / Notches	BV 920
 } 3 Crans / Notches	BV 930
 } 4 Crans / Notches	

NOUVEAUX JOINTS METAL-ELASTOMERE (5 + 1 épaisseurs différentes) STEEL ELASTOMER GASKETS (5 + 1 different thicknesses)	
 } 1 Cran / Notch	BX 930 Ép. / Thick. = 1,36 mm*
 } 2 Crans / Notches	BX 940 Ép. / Thick. = 1,40 mm*
 } 3 Crans / Notches	BX 950 Ép. / Thick. = 1,44 mm*
 } 4 Crans / Notches	BX 960 Ép. / Thick. = 1,48 mm*
 } 5 Crans / Notches	BX 970 Ép. / Thick. = 1,52 mm*
 } 0 Cran / Notch	BX 980 Ép. / Thick. = 1,59 mm* Pour bloc rectifié For resurfaced block

* L'épaisseur indiquée correspond à l'épaisseur serrée sur moteur.
* The above thickness refers to the assembled thickness.

IDENTIFICATION JOINTS DE CULASSE - Moteur Diesel CYLINDER HEAD GASKET IDENTIFICATION - Diesel Engine PEUGEOT - CITROËN - Moteur / Engine XUD11 ATA et / and BTE

Moteurs / Engines XUD11 ATE et / and BTE → Alésage / Bore = 85 mm - 2088 cm³

Anciens joints de culasse fibreux 4 épaisseurs
Old fiber gaskets (4 different thicknesses)

Nouveaux joints métalliques multifeuilles (5+2 classes)
New multi-layer steel gaskets

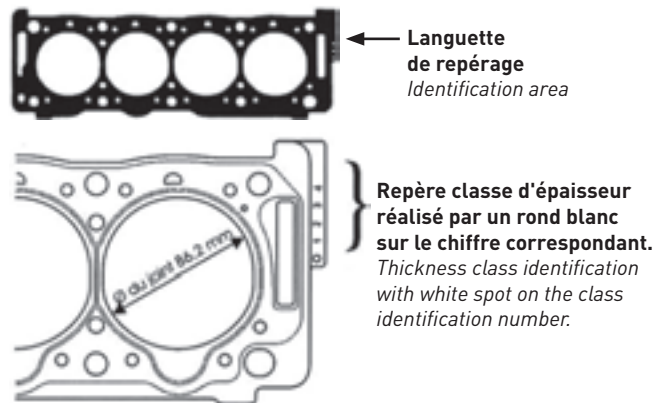
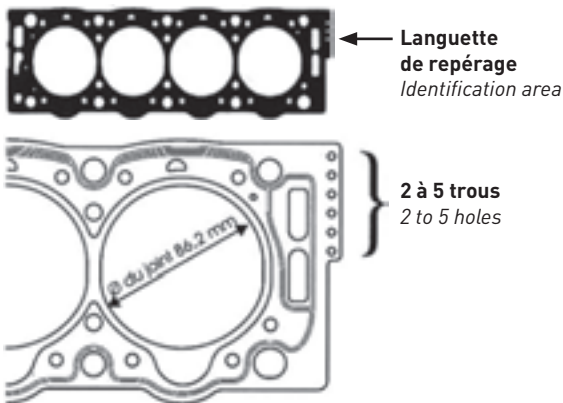

ANCIENS JOINTS FIBREUX (4 épaisseurs différentes) OLD FIBER GASKETS (4 different thicknesses)	
	2 Trous / Holes
	3 Trous / Holes
	4 Trous / Holes
	5 Trous / Holes

ANCIENS JOINTS FIBREUX (5 classes) OLD FIBER GASKETS (3 classes)	NOUVEAUX JOINTS MÉTALLIQUES MULTIFEUILLES (3 + 2 classes) NEW MULTI-LAYER STEEL GASKETS (3 + 2 classes)	
		BY 930 Classe / Class 0 (1 + 2 trous / holes) Ép. / Thick. = 1,35 mm*
		BY 941 Classe / Class 1 Ép. / Thick. = 1,52 mm*
		BY 961 Classe / Class 2 Ép. / Thick. = 1,62 mm*
		BY 981 Classe / Class 3 Ép. / Thick. = 1,72 mm*
		BY 990 Classe / Class 6 (1 + 4 trous / holes) Ép. / Thick. = 1,77 mm*

Attention: mesurer systématiquement les dépassements de pistons au PMH pour déterminer le joint de culasse d'épaisseur optimale (voir les notes techniques en fin de catalogue pour identifier la correspondance entre le dépassement du piston et la réf. de joint).

Warning: it is strongly recommended that the gasket selection be made after measuring the UDC piston protrusion; see the technical notes at the end of the catalogue to have the link between the piston protrusion and the gasket part number.

* L'épaisseur correspond à l'épaisseur serrée sur moteur.
* The above thickness refers to the assembled thickness.

IDENTIFICATION JOINTS DE CULASSE - Moteur Diesel CYLINDER HEAD GASKET IDENTIFICATION - Diesel Engine PEUGEOT - CITROËN - Moteur DW8 Atmo / DW8 N.A. Engine

Moteurs / Engines DW8 Atmo / DW8 N.A.



Languette de repérage
Identification area

	1 Trou /Hole	AA5830 Ép. / Thick. = 1,26 mm*
	2 Troux /Holes	AA5840 Ép. / Thick. = 1,30 mm*
	3 Troux /Holes	AA5850 Ép. / Thick. = 1,34 mm*
	4 Troux /Holes	AA5860 Ép. / Thick. = 1,38 mm*
	5 Troux /Holes	AA5870 Ép. / Thick. = 1,42 mm*
	2 Troux /Holes	AA5880 Ép. / Thick. = 1,46 mm*
<p>* L'épaisseur correspond à l'épaisseur serrée sur moteur. * The above thickness refers to the assembled thickness.</p>		

Attention: mesurer systématiquement les dépassements de pistons au PMH pour déterminer le joint de culasse d'épaisseur optimale (voir les notes techniques en fin de catalogue pour identifier la correspondance entre le dépassement du piston et la réf. de joint).



Warning: it is strongly recommended that the gasket selection be made after measuring the UDC piston protrusion; see the technical notes at the end of the catalogue to have the link between the piston protrusion and the gasket part number.

IDENTIFICATION JOINTS DE CULASSE - Moteur Diesel CYLINDER HEAD GASKET IDENTIFICATION - Diesel Engine PEUGEOT - CITROËN - Moteur DW10 Turbo / DW10 T.C. Engine

Moteurs / Engines DW10 Turbo / DW10 T.C.



Languette de repérage
Identification area

	1 Cran /Noth	AC5011 Ép. / Thick. = 1,30 mm*
	3 Crans /Nothes	AC5031 Ép. / Thick. = 1,40 mm*
	5 Crans /Nothes	AC5051 Ép. / Thick. = 1,50 mm*
<p>* L'épaisseur correspond à l'épaisseur serrée sur moteur. * The above thickness refers to the assembled thickness.</p>		

Attention: mesurer systématiquement les dépassements de pistons au PMH pour déterminer le joint de culasse d'épaisseur optimale (voir les notes techniques en fin de catalogue pour identifier la correspondance entre le dépassement du piston et la réf. de joint).











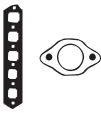

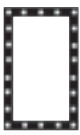

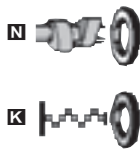



Warning: it is strongly recommended that the gasket selection be made after measuring the UDC piston protrusion; see the technical notes at the end of the catalogue to have the link between the piston protrusion and the gasket part number.



KW/PS



2 CV 6						02/70 → 07/90	1	DF050▲■○	GF051▲○ [12] (20-22547-03/0)
A06/664	602	2	74.00	Carburettor, OHV	20-21/ 27-29				
A06/635	602	2	74.00	Carburettor	21/29				
M28/1 (AK2)	602	2	74.00	Carburettor, OHV	21/29				
Acadiane Van 6						08/78 → 10/88	2	DF050▲■○	GF051▲○ [12] (20-22547-03/0)
M28 (AM2)	602	2	74.00	Carburettor, OHV	21/29				
AX 10						07/86 → 12/98	3	BS810 (Fibre), 1.30mm (30-026850-00)	DS810 (21-26850-20/0)
AX 10 E						12/86 → 12/88		BR490 (Fibre), 1.50mm [34] (30-029800-00)	DT012▲ (21-26853-20/0)
C1A	954	4	70.00	Carburettor	32/45				
C3A (TU9)	954	4	70.00	Carburettor	33/45				
TU9 (C1A)	954	4	70.00	Carburettor, SOHC	33/45				
TU9M (CDY/CDZ)	954	4	70.00	SPi, SOHC	40/54				
AX 11						09/86 → 12/97	4	AD5700 (Fibre), 1.25mm (30-026851-00)	DT010 (21-26851-20/0)
AX 11 4x4						06/91 → 07/92		AD5710 (Fibre), 1.50mm [34] (30-029799-00)	DT012▲ (21-26853-20/0)
TU1CP (HAZ)/TU1M (H1A)	1124	4	72.00	Carburettor	40/54				
TU1 (H1A)	1124	4	72.00	Carburettor	40-44/ 54-60				
TU1 (H1B)	1124	4	72.00	Injection, SOHC	40-44/ 55-60				
AX 1.3L Sport						04/87 → 12/88	5	AD5700 (Fibre), 1.25mm (30-026851-00)	DT013▲ (21-26853-22/0)
TU2.4 (M4A)	1294	4	75.00	Carburettor	70/95			AD5710 (Fibre), 1.50mm [34] (30-029799-00)	EH951 (8) (22-25605-00/0)
									EH952 (22-25605-02/0)
AX 1.4L GTi						06/91 → 12/96	6	AY110 (Fibre)	DY130▲ (21-26853-21/0)
TU3FJ2 (KFY)	1360	4	75.00	MPi, Cast iron head	66/89			BY170 (Fibre), 1.50mm [34]	EY130 (22-28758-00/0)
TU3FJ2 (KFZ)	1360	4	75.00	MPi, Cast iron head	69/94				
AX 14						12/86 → 12/89	7	AD5700 (Fibre), 1.25mm (30-026851-00)	DT010 (21-26851-20/0)
TU3CP (KAY)	1360	4	75.00	Carburettor	44/60			AD5710 (Fibre), 1.50mm [34] (30-029799-00)	EH951 (8) (22-25605-00/0)
TU3F2 (K1F)	1360	4	75.00	Carburettor	49/67				DT012▲ (21-26853-20/0)
									EH952 (22-25605-02/0)
AX 14						01/88 → 12/92	8	BY130 (Fibre), 1.28mm (30-029099-00)	DY130▲ (21-26853-21/0)
TU3F2 (K2B)	1360	4	75.00	Carburettor, Cast iron head	62/84			BY170 (Fibre), 1.50mm [34]	EY130 (22-28758-00/0)
TU3FM (K2A)	1360	4	75.00	SPi, Cast iron head	62/84				











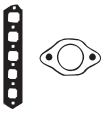

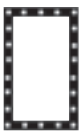





























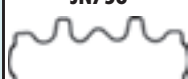

























































								
		JB864 (x2) JB830 (x2)	JN232 (x2)	PA217 16.3x22x2mm		NF812 30x42x8mm, ACM (50-319440-00) NF747 55.5x69x10mm, ACM NF809 56x69x10mm, FPM/ACM	NF036 (x6) [2] NF505 (x2) [38] LT639 (x2) [119] →12/73 NF577 (x8) [141]	 AD5700, AD5710  BS810, BR490  BY130  BY170  JB830  JB864  JC702  JD551  JE189  JN232  JN658  JJ586  JJ587
		JB864 (x2) JB830 (x2)	JN232 (x2)	PA217 16.3x22x2mm		NF812 30x42x8mm, ACM (50-319440-00) NF809 56x69x10mm, FPM/ACM NF747 55.5x69x10mm, ACM	NF036 (x6) [2] NF505 (x2) [38] LT639 (x2) [119] →12/73 NF577 (x8) [141]	
HBS039 (22-15010B) M10x1.50x175mm (x10)	JD551 (x2) (31-029803-00) JC702 (x2) (31-029804-00)	JN658 (50-026853-00)	JJ586 (31-029806-00) PB852 16x24x1.5mm PA349 (33-102290-10) 22x16x2mm	HR642	NF817 36x50x7mm, FPM (50-319112-00) NF857 85x105x9mm, FPM/ACM (50-319478-00) NF870 42x66x6mm, FPM/ACM (50-319113-00)	HL5011 [245] HR564 [37] NF836 [38] NF826 [38] PA850 [13] PA858 [13]		
HBS039 (22-15010B) M10x1.50x175mm (x10)	JD551 (x2) (31-029803-00) JC702 (x2) (31-029804-00) JE189 (31-029805-00)	JN658 (50-026853-00)	JJ586 (31-029806-00) PB852 16x24x1.5mm PA349 (33-102290-10) 22x16x2mm	HR642	NF817 36x50x7mm, FPM (50-319112-00) NF870 42x66x6mm, FPM/ACM (50-319113-00) NF857 85x105x9mm, FPM/ACM (50-319478-00)	HL5011 [245] HR564 [37] NF836 [38] NF826 [38] PA850 [13] PA858 [13]		
HBS039 (22-15010B) M10x1.50x175mm (x10)	JC702 (x2) (31-029804-00) JE189 (31-029805-00)	JN658 (50-026853-00)	JJ586 (31-029806-00) PB852 16x24x1.5mm PA349 (33-102290-10) 22x16x2mm	HR569 24-30667-00/0	NF817 36x50x7mm, FPM (50-319112-00) NF870 42x66x6mm, FPM/ACM (50-319113-00) NF857 85x105x9mm, FPM/ACM (50-319478-00)	HL5011 [245] HR564 [37] NF836 [38] NF826 [38] PA850 [13] PA858 [13]		
HBS039 (22-15010B) M10x1.50x175mm (x10)	HA5028 (x2) JC702 (x2) (31-029804-00) JE189 (31-029805-00)	JN658 (50-026853-00)	JJ587 PB852 16x24x1.5mm	HR642	NF817 36x50x7mm, FPM (50-319112-00) NF870 42x66x6mm, FPM/ACM (50-319113-00) NF857 85x105x9mm, FPM/ACM (50-319478-00)	HL5011 [245] HR564 [37] NF836 [38] NF826 [38]		
HBS039 (22-15010B) M10x1.50x175mm (x10)	JD551 (x2) (31-029803-00) JC702 (x2) (31-029804-00)	JN658 (50-026853-00)	JJ586 (31-029806-00) PB852 16x24x1.5mm PA349 (33-102290-10) 22x16x2mm	HR642	NF817 36x50x7mm, FPM (50-319112-00) NF870 42x66x6mm, FPM/ACM (50-319113-00) NF857 85x105x9mm, FPM/ACM (50-319478-00)	HL5011 [245] HR564 [37] NF836 [38] NF826 [38] PA850 [13] PA858 [13]		
HBS039 (22-15010B) M10x1.50x175mm (x10)	JC702 (x2) (31-029804-00) JE189 (31-029805-00)	JN658 (50-026853-00)	JJ587 PB852 16x24x1.5mm	HR642	NF817 36x50x7mm, FPM (50-319112-00) NF870 42x66x6mm, FPM/ACM (50-319113-00) NF857 85x105x9mm, FPM/ACM (50-319478-00)	HL5011 [245] HR564 [37] NF836 [38] NF826 [38]		



KW/PS



AX 14				04/87 → 04/97		9	AD5700 (Fibre), 1.25mm (30-026851-00)		DT010 (21-26851-20/0)	EH951 [8] (22-25605-00/0)
TU3FM (KDY)/ TU3M (KDX)/ TU3M (KDY)/ TU3M/Z (KDZ)	1360	4	75.00	SPi, SOHC	55/75	TU3M BY130 (Fibre), 1.28mm (30-029099-00) TU3FM AD5710 (Fibre), 1.50mm [34] (30-029799-00) TU3M BY170 (Fibre), 1.50mm [34] TU3FM	TU3M DT012▲ (21-26853-20/0) TU3M DY130▲ (21-26853-21/0) TU3FM	TU3M EH952 (22-25605-02/0) TU3M EY130 (22-28758-00/0) TU3FM		
AX 14 4x4				08/91 → 12/96		10	AD5700 (Fibre), 1.25mm (30-026851-00)		DT010 (21-26851-20/0)	EH951 [8] (22-25605-00/0)
TU3FM (KDY)/ TU3M (KDX)/ TU3M (KDY)/ TU3M/Z (KDZ)	1360	4	75.00	SPi, SOHC	55/75	TU3M BY130 (Fibre), 1.28mm (30-029099-00) AD5710 (Fibre), 1.50mm [34] (30-029799-00) TU3M BY170 (Fibre), 1.50mm [34] TU3FM	TU3M DT012▲ (21-26853-20/0) TU3M DY130▲ (21-26853-21/0) TU3FM	TU3M EH952 (22-25605-02/0) TU3M EY130 (22-28758-00/0) TU3FM		
AX 14 D Diesel				09/88 → 12/97		11	BS730 (Steel Elastomer), 1.80mm (30-026845-20)		DS731▲ (21-26844-21/0)	EH951 [8] (22-25605-00/0) EH952 (22-25605-02/0)
TUD3 (K9A/ K9Y)/TUD3 (K9Y)	1360	4	75.00	SOHC	39/53	BY120 (Fibre), 1.80mm (30-029802-00)				
AX 15 D Diesel				08/94 → 12/97		12	BY150 (Fibre), 1.75mm (30-028735-00)		DY150▲ (21-28737-20/0)	
TUD5 (VJY)/TUD5 (VJZ)	1527	4	77.00		42/57					
Axel 11				01/84 → 03/91		13		DF490▲○	GF492▲○	
G11/631	1129	4	74.00	Carburettor	41/43/ 56/58					
Axel 11				01/84 → 03/91		14		DF490▲○	GF492▲○	
	1299	4			45/61					
Berlingo 1.1L i				07/96 →		15	AC5700 (Fibre), 1.26mm (30-029572-00)		CC5700 (21-29572-20/0)	EH951 [8] (22-25605-00/0)
Berlingo Van 1.1L i				07/96 →			TU1JP BS810 (Fibre), 1.30mm (30-026850-00) TU1M+ BR490 (Fibre), 1.50mm [34] (30-029800-00) TU1M+		TU1JP DT012▲ (21-26853-20/0) TU1M+	TU1M+ EH952 (22-25605-02/0) TU1M+
TU1M (H1A)	1124	4	72.00	Carburettor	40/54					
TU1JP (HFX)	1124	4	72.00	MPi, SOHC	44/60					
Berlingo 1.4L i				07/96 →		16	AD5700 (Fibre), 1.25mm (30-026851-00)		DT012▲ (21-26853-20/0)	EH951 [8] (22-25605-00/0)
Berlingo Van 1.4L i				07/96 →			BY130 (Fibre), 1.28mm (30-029099-00) AD5710 (Fibre), 1.50mm [34] (30-029799-00)			
TU3JP (KFW)/TU3JP (KFX)	1360	4	75.00	MPi, SOHC	55/75					











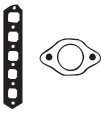

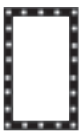

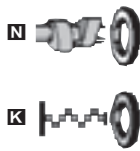













































































								 AC5700	 JJ587
HBS039  (22-15010B) M10x1.50x175mm (x10)	JD551  (x2) (31-029803-00) JC702  (x2) (31-029804-00)  JE189 (31-029805-00)	JN658 (50-026853-00)	JJ586 (31-029806-00) TU3M JJ587 TU3FM ● PB852 16x24x1.5mm ● PA349 (33-102290-10) 22x16x2mm	HR642 	 NF817 36x50x7mm, FPM (50-319112-00)  NF870 42x66x6mm, FPM/ACM (50-319113-00)  NF857 85x105x9mm, FPM/ACM (50-319478-00)	HL5011 [245]  HR564 [37]  NF836 [38]  NF826 [38]  PA850 [13] TU3M PA858 [13] TU3M	 AD5700, AD5710  BS730, BY120  BS810, BR490  BY130  BY150  BY170  JB833  JC702  JD538  JD551  JE189  JF067  JN658  JN758  JP041  JJ586		
HBS039  (22-15010B) M10x1.50x175mm (x10)	JD551  (x2) (31-029803-00) JC702  (x2) (31-029804-00)  JE189 (31-029805-00)	JN658 (50-026853-00)	JJ586 (31-029806-00) TU3M JJ587 TU3FM ● PB852 16x24x1.5mm ● PA349 (33-102290-10) 22x16x2mm	HR642 	 NF817 36x50x7mm, FPM (50-319112-00)  NF870 42x66x6mm, FPM/ACM (50-319113-00)  NF857 85x105x9mm, FPM/ACM (50-319478-00)	HL5011 [245]  HR564 [37]  NF836 [38]  NF826 [38]  PA850 [13] TU3M PA858 [13] TU3M			
HBS082  (22-15001B) M10x1.50x185mm (x10)	 JF067	JN758	JJ586 (31-029806-00) ● PA349 (33-102290-10) 22x16x2mm	HR642 	 NF817 36x50x7mm, FPM (50-319112-00)  NF870 42x66x6mm, FPM/ACM (50-319113-00)  NF857 85x105x9mm, FPM/ACM (50-319478-00)	HL5011 [245]  HR564 [37]  NF836 [38]  NF826 [38]  PA850 [13] PA858 [13] PB259 [14]			
HBS113  (22-15015B) M11x1.50x185mm (x10)		JP041 (50-028757-00)	JJ587 ● PB907 14x21x2mm	HR642 	 NF817 36x50x7mm, FPM (50-319112-00)  NF870 42x66x6mm, FPM/ACM (50-319113-00)  NF857 85x105x9mm, FPM/ACM (50-319478-00)	HL5011 [245]  NF836 [38]  NF826 [38]  PB259 [14]			
	JB833  (x4)		● PA217 16.3x22x2mm		 NF677 (x2) 28x52x10mm, ACM  NF764 57.5x120x10mm, FPM/ACM	NF812 [15]			
	JB833  (x4)		● PA217 16.3x22x2mm		 NF677 (x2) 28x52x10mm, ACM  NF764 57.5x120x10mm, FPM/ACM	NF812 [15]			
HBS039  (22-15010B) M10x1.50x175mm (x10)	JD551  (x2) (31-029803-00) TU1M+ JD5828  HA5028  JC702  (x2) (31-029804-00)  JE189 (31-029805-00)	JN658 (50-026853-00)	JJ586 (31-029806-00) TU1M+ ● PB852 16x24x1.5mm ● PA349 (33-102290-10) 22x16x2mm	HR642 	 NF817 36x50x7mm, FPM (50-319112-00)  NF870 42x66x6mm, FPM/ACM (50-319113-00)  NF857 85x105x9mm, FPM/ACM (50-319478-00)	HL5011 [245]  HR564 [37]  NA5205 [38]  NA5204 [38]  PA850 [13] PA858 [13]			
HBS039  (22-15010B) M10x1.50x175mm (x10)	JD538  (x4) (31-029472-00) JD5828  HA5028  JC702  (x2) (31-029804-00)  JE5072 (MLS)	JN658 (50-026853-00)	● PB852 16x24x1.5mm	HR642 	 NF817 36x50x7mm, FPM (50-319112-00)  NF870 42x66x6mm, FPM/ACM (50-319113-00)  NF857 85x105x9mm, FPM/ACM (50-319478-00)	HL5011 [245]  HR564 [37]  NA5205 [38]  NA5204 [38]  PA850 [13]			



KW/PS



Berlingo 1.4L i Bivalent					11/02 →	17	AD5700 (Fibre), 1.25mm (30-026851-00)	DT012▲ (21-26853-20/0)	EH951 [8] (22-25605-00/0)
TU3FJ2 (K2D)	1360	4				48/65	AD5710 (Fibre), 1.50mm [34] (30-029799-00)		
TU3FM (KDY)	1360	4	75.00	Carburettor		55/75			
TU3JP (KFW)/TU3JP (KFX)	1360	4	75.00	SPi, SOHC		55/75			
TU3M (KDX)/TU3M (KDY)/TU3M/Z (KDZ)	1360	4	75.00	MPi, SOHC		55/75			
TU3M (KDX)/TU3M (KDY)/TU3M/Z (KDZ)	1360	4	75.00	SPi, SOHC		55/75			
Berlingo 1.6L 16V					10/00 →	18	AD5180 (MLS), 0.62mm (30-029785-00)	CD5180 (21-29785-20/0)	ED5180
Berlingo Van 1.6L 16V					10/00 →				
TU5JP4 (NFU/N6A)	1587	4	78.50	SPi		80/109			
Berlingo 1.6L HDI 75 Diesel					07/05 →	19	AD5130 (MLS), 1.25mm, 2 Notches, +3 Notches (30-029277-00)	CD5140▲ (21-29278-00/0)	
Berlingo 1.6L HDI 90 Diesel					07/05 →				
DV6B	1560	4	75.00	HDi		55/75	AD5140 (MLS), 1.30mm, 3 Notches, +3 Notches (30-029278-00)		
DV6ATED4	1560	4	75.00	HDi		66/90	AD5150 (MLS), 1.35mm, 1 Notch, +3 Notches (30-029279-00)		
							AD5160 (MLS), 1.40mm, +3 Notches, 4 Notches (30-029280-00)		
							AD5170 (MLS), 1.45mm, +3 Notches, 5 Notches (30-029281-00)		
Berlingo Van 1.6L HDI 75 Diesel					07/05 →	20	AD5130 (MLS), 1.25mm, 2 Notches, +3 Notches (30-029277-00)	CD5140▲ (21-29278-00/0)	
DV6B	1560	4	75.00	HDi		55/75	AD5140 (MLS), 1.30mm, 3 Notches, +3 Notches (30-029278-00)		
							AD5150 (MLS), 1.35mm, 1 Notch, +3 Notches (30-029279-00)		
							AD5160 (MLS), 1.40mm, +3 Notches, 4 Notches (30-029280-00)		
							AD5170 (MLS), 1.45mm, +3 Notches, 5 Notches (30-029281-00)		
Berlingo 1.8L i 4WD					04/97 →	21	BL650 (Fibre), 1.20mm (30-026859-10)	DL651▲ (21-28759-22/0)	EL650 (22-25198-00/0)
Berlingo 1.8L i					05/97 →				
Berlingo Van 1.8L i					08/99 → 10/02		BR510 (Fibre), 1.44mm [34] (30-026858-10)		
XU7JB (LFX)	1761	4	83.00	MPi		66/89			
Berlingo 1.8L D Diesel					07/98 →	22	BX830 (Fibre), 1.36mm, 1 Notch (30-028484-00)	DJ720▲ (21-25202-22/0)	EL890 (22-25198-01/0)
Berlingo Van 1.8L D Diesel					07/96 →				GJ720▲ (20-25202-02/0)
XUD7 (A9A/161A)	1769	4	80.00			44/60	→0.56 →0.67mm		
							BX840 (Fibre), 1.40mm, 2 Notches (30-028485-00)		
							→0.68 →0.71mm		
							BX850 (Fibre), 1.44mm, 3 Notches (30-028486-00)		
							→0.72 →0.75mm		
							BX860 (Fibre), 1.48mm, 4 Notches (30-028487-00)		
							→0.76 →0.79mm		
							BX870 (Fibre), 1.52mm, 5 Notches (30-028488-00)		
							→0.80 →0.83mm		

								
HBS039  [22-15010B] M10x1.50x175mm (x10)	JD538  (x4) (31-029472-00) JC702  (x2) (31-029804-00)  JE5072 (MLS)	JN658 (50-026853-00)	 PB852 16x24x1.5mm	HR642 	 NF817 36x50x7mm, FPM (50-319112-00)  NF870 42x66x6mm, FPM/ACM (50-319113-00)  NF857 85x105x9mm, FPM/ACM (50-319478-00)	HL5011 [245]  HR564 [37]  NA5205 [38]  NA5204 [38]  PA850 [13]	 AD5130, AD5140, AD5150, AD5160, AD5170  AD5180  AD5700, AD5710  BL650  BX830, BX840, BX850, BX860, BX870  JC702  JC759  JD520  JD538  JN544  JN658  JP043  JJ283	
HBS254  [22-53009B] M10x1.50x122mm (x10)	HA5032   [24-35043-10/0] JD5831   JE5072 (MLS)	JM7035 (50-030267-00)	JH5107 (ACM)  PB852 16x24x1.5mm  PA349 (33-102290-10) 22x16x2mm		 NA5260 38x50x6mm  NF870 42x66x6mm, FPM/ACM (50-319113-00)  NF857 85x105x9mm, FPM/ACM (50-319478-00)	HL5038 [245]  NA5205 [38]  NA5204 [38] 		
HBS359  [22-15018B] M11x1.50x150mm (x10)	JD5830   (50-030266-00) HA5031    [24-35043-00/0] HA5030    [24-35042-90/0] JD5829  (31-030265-00)	JM7034 (50-030264-00)	 KG5157 10x20x2mm		 NA5258 27x47x7mm  NA5259 40x55x6.4mm	HL5033 [245] 		
HBS359  [22-15018B] M11x1.50x150mm (x10)	JD5830   (50-030266-00) HA5031    [24-35043-00/0] HA5030    [24-35042-90/0] JD5829  (31-030265-00)	JM7034 (50-030264-00)	 KG5157 10x20x2mm		 NA5258 27x47x7mm  NA5259 40x55x6.4mm			
HBS260  [22-53011B] M11x1.50x168mm (x10)	JD520  (x4)	JP043 (50-028759-00)	 PB907 14x21x2mm	HR569  24-30667-00/0	 NF817 36x50x7mm, FPM (50-319112-00)  NA5191 42x62x7mm, PTFE (50-319500-00)  NA5192 90x110x7mm, PTFE (50-319501-00)	HL5019 [245]  HR566 [37]  NA5205 [38]  NA5204 [38]  KA611 [13]		
HBS084  [22-15005B] M12x1.50x123mm (x10) →Eng.08469 HBS245  [22-53008B] M12x1.50x125mm (x10) Eng.08470 →	JC759 [60] (31-028417-00) (Steel)	JN544 (50-025202-00)	JJ283 [6] (31-025198-10)  PB907 14x21x2mm	HR569  24-30667-00/0	 NB959 35x50x7mm, FPM (50-306644-50)  NA5191 42x62x7mm, PTFE (50-319500-00)  NA5192 90x110x7mm, PTFE (50-319501-00)	HL5012 [245]  NA5205 [38]  NA5204 [38]  KA611 [13]		



KW/PS



Berlingo 1.9L D Diesel 07/98 → 23		AA5830 (Steel Elastomer), 1.26mm, 1 Hole (30-029190-00)		CA5830▲ (21-29482-20/0)	EA5830		
Berlingo 1.9L D 4WD Diesel 07/98 →		\pm 0.51 → 0.54mm					
Berlingo Van 1.9L D 70 Diesel 04/99 →		AA5840 (Steel Elastomer), 1.30mm, 2 Holes (30-029191-00)					
Berlingo Van 1.9L D 70 4WD Diesel 07/98 →		\pm 0.55 → 0.58mm					
DW8 (WJZ) / DW8B (WJY)/DW8B (WJY)	1868	4	82.20	SOHC	51/70	AA5850 (Steel Elastomer), 1.34mm, 3 Holes (30-029192-00)	EL890 (22-25198-01/0) GJ720▲ (20-25202-02/0)
						\pm 0.59 → 0.62mm	
						AA5860 (Steel Elastomer), 1.38mm, 4 Holes (30-029193-00)	
						\pm 0.63 → 0.66mm	
						AA5870 (Steel Elastomer), 1.42mm, 5 Holes (30-029194-00)	
						\pm 0.67 → 0.70mm	
						AA5880 (Steel Elastomer), 1.46mm, 6 Holes (30-029195-00)	
						\pm 0.71 → 0.75mm	
Berlingo 1.9L D Diesel 07/96 → 24		BX880 (Fibre), 1.36mm, 1 Notch (30-028475-00)		DJ720▲ (21-25202-22/0)	EL890 (22-25198-01/0) GJ720▲ (20-25202-02/0)		
XUD9A/L (D9B) 1905 4 83.00 SOHC 50/68		\pm 0.56 → 0.67mm					
XUD9A (DJY/D9B) 1905 4 83.00		BX890 (Fibre), 1.40mm, 2 Notches (30-028476-00)					
		\pm 0.68 → 0.71mm					
		BX900 (Fibre), 1.44mm, 3 Notches (30-028477-00)					
		\pm 0.72 → 0.75mm					
		BX910 (Fibre), 1.48mm, 4 Notches (30-028478-00)					
		\pm 0.76 → 0.79mm					
		BX920 (Fibre), 1.52mm, 5 Notches (30-028479-00)					
		\pm 0.80 → 0.83mm					
Berlingo 2.0L HDI Diesel 11/02 → 10/05 25		AC5011 (MLS), 1.30mm, 1 Hole \pm 0.47 → 0.605mm		CC5010▲ (21-29484-20/0)	EA5830		
DW10TD 1997 4 85.00 Direct Injection 66/89		AC5031 (MLS), 1.40mm, 3 Holes (30-029479-10)					
		\pm 0.655 → 0.705mm					
Berlingo 2.0L HDI 4x4 Diesel 11/02 → 10/05 26		AC5011 (MLS), 1.30mm, 1 Hole \pm 0.47 → 0.605mm		CC5010▲ (21-29484-20/0)	EA5830		
Berlingo 2.0L HDI 90 Diesel 12/99 →		AC5031 (MLS), 1.40mm, 3 Holes (30-029479-10)					
Berlingo Van 2.0L HDI 90 Diesel 12/99 →		\pm 0.655 → 0.705mm					
Berlingo Van 2.0L HDI 90 4WD Diesel 11/00 →		AC5051 (MLS), 1.50mm, 5 Holes (30-029481-10)					
DW10TD 1997 4 85.00 Direct Injection 66/89						\pm 0.755 → 0.83mm	
DW10TD (RHY) 1998 4 85.00 Common Rail 63/86							
BX 11 10/88 → 06/92 27		AD5700 (Fibre), 1.25mm (30-026851-00)		DT010 (21-26851-20/0)	EH951 (8) (22-25605-00/0)		
TU1M (H1A) 1124 4 72.00 Carburettor 40/54		AD5710 (Fibre), 1.50mm [34] (30-029799-00)				DT012▲ (21-26853-20/0)	EH952 (22-25605-02/0)

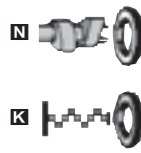
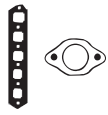

AA5830, AA5840,
AA5850, AA5860,
AA5870, AA5880



AD5700, AD5710



BX880, BX890,
BX900, BX910,
BX920



JC702



JC759



JD551



JE189



JN544



JN658



JJ283









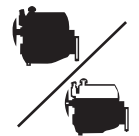



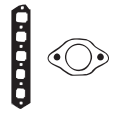

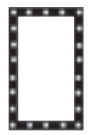

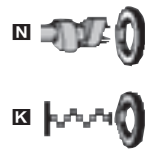

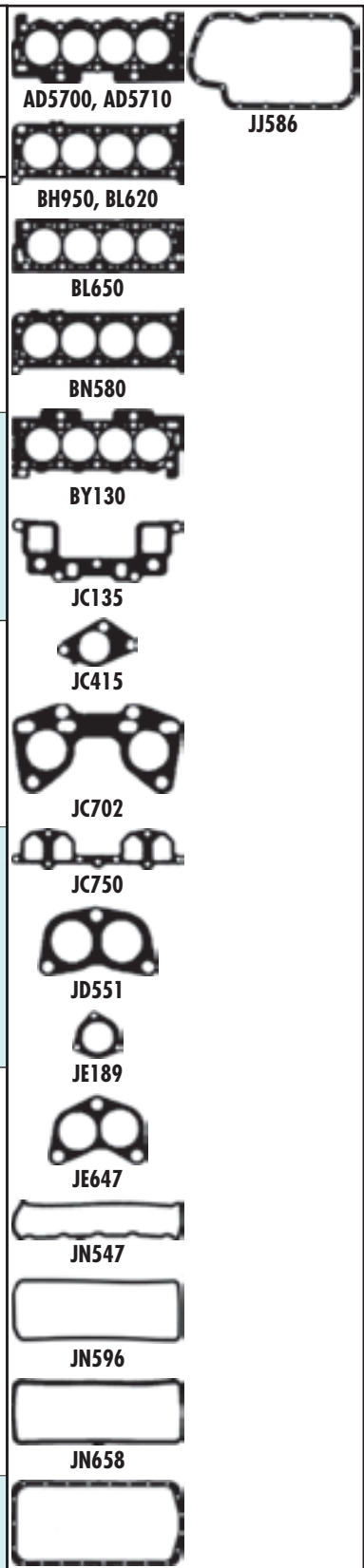















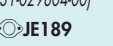











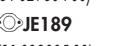































JJ586



KW/PS



BX 11		10/86 → 06/92			28	BH950 (Fibre), 1.20mm, 1 Notch [33] (30-025152-10) →12/85 BL620 (Fibre), 1.40mm [33][34] →12/85 BN580 (Fibre), 1.20mm [35] (30-026021-10) 01/86 →	DN571▲	EH950 [36]
	1124	4			42/57			
BX 14		01/89 → 12/89			29	AD5700 (Fibre), 1.25mm (30-026851-00) AD5710 (Fibre), 1.50mm [34] (30-029799-00)	DT010 (21-26851-20/0) DT012▲ (21-26853-20/0)	EH951 [8] (22-25605-00/0) EH952 (22-25605-02/0)
TU3A (K1H)	1360	4	75.00	Carburettor	47-49/ 64-67			
BX 14		01/89 → 02/93			30	AD5700 (Fibre), 1.25mm (30-026851-00) BY130 (Fibre), 1.28mm (30-029099-00) AD5710 (Fibre), 1.50mm [34] (30-029799-00)	DT010 (21-26851-20/0) DT012▲ (21-26853-20/0)	EH951 [8] (22-25605-00/0) EH952 (22-25605-02/0)
TU3M (KDY)/TU3M/Z (KDZ)	1360	4	75.00	SPi, SOHC	55/75			
BX 14 BX 14 E		01/86 → 02/93 10/82 → 02/93			31	BH950 (Fibre), 1.20mm, 1 Notch [33] (30-025152-10) →11/85 BL620 (Fibre), 1.40mm [33][34] →11/85 BN580 (Fibre), 1.20mm [35] (30-026021-10) 11/85 →	DN582▲	EH950 [36]
XY6C (150A)	1360	4		Carburettor	59/80			
XY6 (150F) / XY8 (150A)	1360	4	75.00	Carburettor, SOHC	46/62 49/67			
K1G	1360	4	75.00	Carburettor	51/69			
XY6D (150C)	1360	4	75.00	Carburettor	53/72			
BX 16 BX 16 E		10/82 → 12/94 05/89 → 02/93			32	BL650 (Fibre), 1.20mm (30-026859-10) BR510 (Fibre), 1.44mm [34] (30-026858-10)	DN590▲ (21-25204-21/0)	EL650 (22-25198-00/0) GL650
XU51C (B1E)	1580	4	83.00	Carburettor, SOHC	53/72			
XU5CP (BAY/BAZ)	1580	4	83.00	MPi	55/75			
XU5S (171D)	1580	4	83.00	Carburettor	64/87			
XU5M (BDY/B4A)/ XU5M (BDZ)	1580	4	83.00	SPi	65/88			
XU5 (171A/171B)	1580	4	83.00	Carburettor	66/90			
XU5S (171C)/ XU51C (B1A) XU52C (B2C)/XU5CP (BAY)	1580	4	83.00	Carburettor	68/92			
XU52C	1580	4	83.00	Carburettor	76/103			
XU5J (180Z)	1580	4	83.00	MPi, SOHC	76/103			
XU5J/J2/JA	1580	4	83.00	MPi	76/103			
BX 16		09/87 → 02/93			33	BL650 (Fibre), 1.20mm (30-026859-10) BR510 (Fibre), 1.44mm [34] (30-026858-10)	DN590▲ (21-25204-21/0)	EL650 (22-25198-00/0) GL650
XU5 (B1AA)	1580	4	83.00	Carburettor, SOHC	58-59/ 79-80			











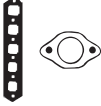

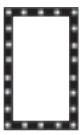

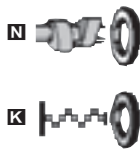

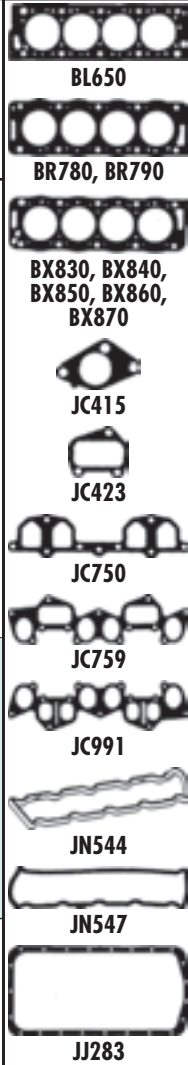







































								
HBS039  (22-15010B) M10x1.50x175mm (x10)	JC135   JE647 [47] (31-022193-10)	JN596 (50-023671-00)	PA349 (33-102290-10) 22x16x2mm	HR569  24-30667-00/0 HR642 	NF817  36x50x7mm, FPM (50-319112-00) NF678  35x50x8mm, ACM NF641  78x100x10mm, MVQ	HR564 [37]  NF526 [2]  NF334 [38] NF836 [38]  HG087 [43] [44]  HG104 [43] [48] 		AD5700, AD5710 BH950, BL620 BL650 BN580 BY130 JC135 JC415 JC702 JC750 JD551 JE189 JE647 JN547 JN596 JN658 JJ283
HBS039  (22-15010B) M10x1.50x175mm (x10)	JD551  (x2) (31-029803-00) JC702  (x2) (31-029804-00)  JE189 (31-029805-00)	JN658 (50-026853-00)	JJ586 (31-029806-00) PB852 16x24x1.5mm PA349 (33-102290-10) 22x16x2mm	HR642 	NF817  36x50x7mm, FPM (50-319112-00) NF870  42x66x6mm, FPM/ACM (50-319113-00) NF857  85x105x9mm, FPM/ACM (50-319478-00)	HL5011 [245]  HR564 [37]  NF836 [38]  NF826 [38]  PA850 [13] PA858 [13]		
HBS039  (22-15010B) M10x1.50x175mm (x10)	JD551  (x2) (31-029803-00) JC702  (x2) (31-029804-00)  JE189 (31-029805-00)	JN658 (50-026853-00)	JJ586 (31-029806-00) PB852 16x24x1.5mm PA349 (33-102290-10) 22x16x2mm	HR642 	NF817  36x50x7mm, FPM (50-319112-00) NF870  42x66x6mm, FPM/ACM (50-319113-00) NF857  85x105x9mm, FPM/ACM (50-319478-00)	HL5011 [245]  HR564 [37]  NF836 [38]  NF826 [38]  PA850 [13] PA858 [13]		
	JC135 	JN596 (50-023671-00)	PA349 (33-102290-10) 22x16x2mm	HR300  (PVC) HR569  24-30667-00/0 (Rubber/Metal)	NF678  35x50x8mm, ACM NF641  78x100x10mm, MVQ	HR564 [37]  NF836 (x2) [38]  HG108 [39] [40]  HL442 [39] [41]  HG092 [43] [44]  LT832 [46]		
HBS038  (22-15003B) M11x1.50x175mm (x10) HBS083  (22-15002B) M11x1.50x168mm (x10)	JC750  JC415  (x4) (31-025205-20)	JN547 (50-025204-10)	JJ283 [6] (31-025198-10) PA349 (33-102290-10) 22x16x2mm PB907 14x21x2mm	HR569  24-30667-00/0	NF817  36x50x7mm, FPM (50-319112-00) NA5191  42x62x7mm, PTFE (50-319500-00) NA5192  90x110x7mm, PTFE (50-319501-00)	HL5019 [245]  HR566 [37]  NF836 [38]  NF826 [38]  KA611 [13] LC292 (x2) [14]		
HBS038  (22-15003B) M11x1.50x175mm (x10) HBS083  (22-15002B) M11x1.50x168mm (x10)	JC750  JC415  (x4) (31-025205-20)	JN658 (50-026853-00)	JJ283 [6] (31-025198-10) PA349 (33-102290-10) 22x16x2mm PB907 14x21x2mm	HR569  24-30667-00/0	NF817  36x50x7mm, FPM (50-319112-00) NA5191  42x62x7mm, PTFE (50-319500-00) NA5192  90x110x7mm, PTFE (50-319501-00)	HL5019 [245]  HR566 [37]  NF836 [38]  NF826 [38]  KA611 [13] LC292 (x2) [14]		



KW/PS



BX 1.8L D Diesel				10/85 → 09/93		34	BX830 (Fibre), 1.36mm, 1 Notch (30-028484-00) 0.56 → 0.67mm BX840 (Fibre), 1.40mm, 2 Notches (30-028485-00) 0.68 → 0.71mm BX850 (Fibre), 1.44mm, 3 Notches (30-028486-00) 0.72 → 0.75mm BX860 (Fibre), 1.48mm, 4 Notches (30-028487-00) 0.76 → 0.79mm BX870 (Fibre), 1.52mm, 5 Notches (30-028488-00) 0.80 → 0.83mm	DJ720 ▲ (21-25202-22/0)	EL890 (22-25198-01/0) GJ720 ▲ (20-25202-02/0)
XUD7 (161)/XUD7 (161A)	1769	4	80.00		44/60				
BX 1.8L TRD Turbo Diesel				03/88 → 12/94		35	BR780 (Fibre), 1.65mm, 2 Notches 0.65 → 0.77mm BR790 (Fibre), 1.80mm, 3 Notches (30-026855-10) 0.77 → 0.82mm	DJ720 ▲ (21-25202-22/0)	EL890 (22-25198-01/0) GJ720 ▲ (20-25202-02/0)
XUD7TE (A8A)/XUD7TE (AJZ)	1769	4	80.00		44/66/60/90				
BX 19				07/86 → 12/94		36	BL650 (Fibre), 1.20mm (30-026859-10) BR510 (Fibre), 1.44mm [34] (30-026858-10)	DL650 DN590 ▲ (21-25204-21/0)	EL650 (22-25198-00/0) GL650
XU9S (159A) XU92C (D2A)	1905 1905	4 4	83.00 83.00	Carburettor Carburettor, SOHC	75/102 76/103				
BX 19				09/86 → 12/89		37	BL650 (Fibre), 1.20mm (30-026859-10) BR510 (Fibre), 1.44mm [34] (30-026858-10)	DN590 ▲ (21-25204-21/0)	EL650 (22-25198-00/0) GL650
XU92C (D2C)	1905	4	83.00	Carburettor	70/95				
BX 19 BX 19 GTi				06/88 → 12/94 06/88 → 02/93		38	BL650 (Fibre), 1.20mm (30-026859-10) BR510 (Fibre), 1.44mm [34] (30-026858-10)	DN590 ▲ (21-25204-21/0)	EL650 (22-25198-00/0) GL650
XU9JA (DKZ)	1905	4	83.00	MPi	90/122				
BX 19 BX 19 E BX 19 GTi				07/86 → 12/94 06/88 → 02/93 07/86 → 02/93		39	BL650 (Fibre), 1.20mm (30-026859-10) BR510 (Fibre), 1.44mm [34] (30-026858-10)	DL650 DN590 ▲ (21-25204-21/0)	EL650 (22-25198-00/0) GL650
XU92C (D2F) XU9M (DDZ) XU9J1 (DFZ)/XU9J2 (D6A)	1905 1905 1905	4 4 4	83.00 83.00 83.00	Carburettor SPi MPi	80/109 80/109 90/122				











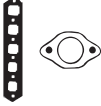

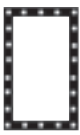

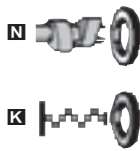













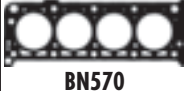





















































								
HBS084  (22-15005B) M12x1.50x123mm (x10) →Eng.08469 HBS245  (22-53008B) M12x1.50x125mm (x10) Eng.08470→	JC423  (x2) (31-025199-10)	JN544 (50-025202-00)	JJ283 [6] (31-025198-10) PA349 (33-102290-10) 22x16x2mm	HR569  24-30667-00/0	NF841 35x50x8mm, FPM (50-319310-00) NA5191  42x62x7mm, PTFE (50-319500-00) NA5192  90x110x7mm, PTFE (50-319501-00)	HL5010 [245]  NF836 [38]  NF826 [38]  KA611 [13]	BL650 BR780, BR790 BX830, BX840, BX850, BX860, BX870 JC415 JC423 JC750 JC759 JC991 JN544 JN547 JJ283	
HBS084  (22-15005B) M12x1.50x123mm (x10)	JC759 [60] (31-028417-00) (Steel) →12/90 →Eng.5407 JC991 (31-028595-00) 01/91→ Eng.5408→	JN544 (50-025202-00)	JJ283 [6] (31-025198-10) PA349 (33-102290-10) 22x16x2mm	HR569  24-30667-00/0	NF841 35x50x8mm, FPM (50-319310-00) NA5191  42x62x7mm, PTFE (50-319500-00) NA5192  90x110x7mm, PTFE (50-319501-00)	HL5010 [245]  NF836 [38]  NF826 [38]  KA611 [13]	JN544 JN547	
HBS038  (22-15003B) M11x1.50x175mm (x10) HBS083  (22-15002B) M11x1.50x168mm (x10)	JC750  JC415  (x4) (31-025205-20)	JN547 (50-025204-10)	JJ283 [6] (31-025198-10) PA349 (33-102290-10) 22x16x2mm PB907 14x21x2mm	HR569  24-30667-00/0	NF817 36x50x7mm, FPM (50-319112-00) NA5191  42x62x7mm, PTFE (50-319500-00) NA5192  90x110x7mm, PTFE (50-319501-00)	HL5019 [245]  HR566 [37]  NF836 [38]  NF826 [38]  LC292 (x2) [14]	JN544 JN547	
HBS038  (22-15003B) M11x1.50x175mm (x10) HBS083  (22-15002B) M11x1.50x168mm (x10)	JC750  JC415  (x4) (31-025205-20)	JN547 (50-025204-10)	JJ283 [6] (31-025198-10) PA349 (33-102290-10) 22x16x2mm PB907 14x21x2mm	HR569  24-30667-00/0	NF817 36x50x7mm, FPM (50-319112-00) NA5191  42x62x7mm, PTFE (50-319500-00) NA5192  90x110x7mm, PTFE (50-319501-00)	HL5019 [245]  HR566 [37]  NF836 [38]  NF826 [38]  LC292 (x2) [14]	JN544 JN547	
HBS038  (22-15003B) M11x1.50x175mm (x10) HBS083  (22-15002B) M11x1.50x168mm (x10)	JC750  JC415  (x4) (31-025205-20)	JN547 (50-025204-10)	JJ283 [6] (31-025198-10) PA349 (33-102290-10) 22x16x2mm PB907 14x21x2mm	HR569  24-30667-00/0	NF817 36x50x7mm, FPM (50-319112-00) NA5191  42x62x7mm, PTFE (50-319500-00) NA5192  90x110x7mm, PTFE (50-319501-00)	HL5019 [245]  HR566 [37]  NF836 [38]  NF826 [38]  KA611 [13] LC292 (x2) [14]	JN544 JN547	



KW/PS



BX 19 D Diesel				09/83 → 12/94		40			DJ720▲ (21-25202-22/0)	EL890 (22-25198-01/0) GJ720▲ (20-25202-02/0)
XUD9 (162)	1905	4	83.00			47/64	BX880 (Fibre), 1.36mm, 1 Notch (30-028475-00) →0.56 →0.67mm			
XUD9 (D9B/DJZ)	1905	4	83.00			55/72	BX890 (Fibre), 1.40mm, 2 Notches (30-028476-00) →0.68 →0.71mm			
XUD9A/U (D9B)	1905	4	83.00	SOHC		66/90	BX900 (Fibre), 1.44mm, 3 Notches (30-028477-00) →0.72 →0.75mm			
							BX910 (Fibre), 1.48mm, 4 Notches (30-028478-00) →0.76 →0.79mm			
							BX920 (Fibre), 1.52mm, 5 Notches (30-028479-00) →0.80 →0.83mm			
BX 19 GTi 16V				09/87 → 02/93		41	BR510 (Fibre), 1.44mm [34] (30-026858-10)		DR510	EL650 (22-25198-00/0)
XU9J4 (D6C/DFW)/XU9J4 (DFW)	1905	4	83.00	MPi		116/158				
C1 1.0L				06/05 →		42	AG9310 (MLS)		CG9310	EG9310
1KR-FE	998	3	71.00	Carburettor		50/68				
C1 1.4L HDI Diesel				06/05 →		43	AD5130 (MLS), 1.25mm, 2 Notches, +3 Notches (30-029277-00) AD5140 (MLS), 1.30mm, 3 Notches, +3 Notches (30-029278-00) AD5150 (MLS), 1.35mm, 1 Notch, +3 Notches (30-029279-00) AD5160 (MLS), 1.40mm, +3 Notches, 4 Notches (30-029280-00) AD5170 (MLS), 1.45mm, +3 Notches, 5 Notches (30-029281-00)		CD5130▲ (21-29277-00/0)	
DV4TD	1398	4	73.70	Direct Injection, SOHC		40/54				
C15 1.0L				11/86 → 05/88		44	BN570 (Fibre), 1.20mm [35] (30-026351-10)		DN571▲	EH950 [36]
XV8 (108C)	954	4	70.00	Carburettor		33/45				
C15 Van 1.0L				10/84 → 12/97		45	BN570 (Fibre), 1.20mm [35] (30-026351-10)		DN571▲	EH950 [36]
TU9/XV8 (108C)	954	4	70.00	Carburettor		33/45				
C15 1.1L E				10/84 → 07/88		46	BH950 (Fibre), 1.20mm, 1 Notch [33] (30-025152-10) →12/85 BL620 (Fibre), 1.40mm [33] [34] →12/85 BN580 (Fibre), 1.20mm [35] (30-026021-10) 01/86 →		DN571▲	EH950 [36]
XW7 (109K)	1124	4	72.00	Carburettor		35/47				
C15 Van 1.1L				10/84 → 12/96		47	BF100 (Fibre), 1.30mm BG480 (Fibre), 1.80mm [34]		DF106▲■○ (21-21887-20/0) DF107▲■	EF102
E1A	1118	4	74.00	Carburettor		40/54				
XW7 (109K)	1124	4	72.00	Carburettor		35/47				











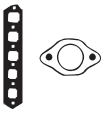

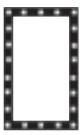

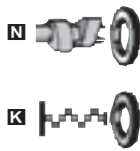









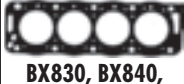



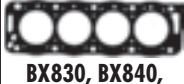











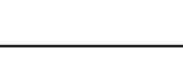









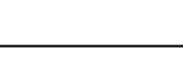

								 AD5130, AD5140, AD5150, AD5160, AD5170
HBS084  (22-15005B) M12x1.50x123mm (x10)	JC759 [60] (31-028417-00) (Steel) JC423  (x2) (31-025199-10)	JN544 (50-025202-00)	JJ283 [6] (31-025198-10) ● PA349 (33-102290-10) 22x16x2mm	HR569  24-30667-00/0	NF841  35x50x8mm, FPM (50-319310-00) NA5191  42x62x7mm, PTFE (50-319500-00) NA5192  90x110x7mm, PTFE (50-319501-00)	HL5010 [245]  NF836 [38]  NF826 [38]  KA611 [13]	 BF100, BG480  BH950, BL620  BN570  BN580  BX880, BX890, BX900, BX910, BX920	
HBS038  (22-15003B) M11x1.50x175mm (x10)	JD5763  (x2) JD5764 	JP044 (50-028763-00)	JJ283 [6] (31-025198-10) ● PA349 (33-102290-10) 22x16x2mm	HR642  (x2)	NF817 (x2) 36x50x7mm, FPM (50-319112-00) NF869 (x2) 32x45x8mm, MVQ NA5191  42x62x7mm, PTFE (50-319500-00) NA5192  90x110x7mm, PTFE (50-319501-00)	HL5019 [245]  HR566 [37]  KA611 [13] LC292 (x2) [14]	 JB836  JB837  JC135  JC423  JC759  JE647	
HBS359  (22-15018B) M11x1.50x150mm (x10)	HA5029   (24-35042-80/0) JD5829  (31-030265-00)	JM7042 (ACM)	● KG5157 10x20x2mm		NA5258 27x47x7mm NA5259  40x55x6.4mm	HL5033 [245] 	 JC135  JC423  JC759  JE647	
		JN596 (50-023671-00)	● PA349 (33-102290-10) 22x16x2mm	HR642 	NF817 36x50x7mm, FPM (50-319112-00) NF678  35x50x8mm, ACM NF641  78x100x10mm, MVQ	HR564 [37]  NF836 (x2) [38]  NF826 [38] 	 JN238  JN544	
HBS039  (22-15010B) M10x1.50x175mm (x10)		JN596 (50-023671-00)	● PA349 (33-102290-10) 22x16x2mm	HR642 	NF817 36x50x7mm, FPM (50-319112-00) NF678  35x50x8mm, ACM NF641  78x100x10mm, MVQ	HR564 [37]  NF836 (x2) [38]  NF826 [38] 	 JN596	
	JC135   JE647 [47] (31-022193-10)	JN596 (50-023671-00)	● PA349 (33-102290-10) 22x16x2mm	HR569  24-30667-00/0 HR642 	NF817 36x50x7mm, FPM (50-319112-00) NF678  35x50x8mm, ACM NF641  78x100x10mm, MVQ	HR564 [37]  NF526 [2]  NF334 [38] NF836 [38]  HG087 [43] [44]  HG104 [43] [48] 	 JP044  HC341	
	JB836  JB837  (31-021888-10)	JN238 (31-021887-00)	HC341  ● PA349 (33-102290-10) 22x16x2mm	HR569  24-30667-00/0 HR642 	NF817 36x50x7mm, FPM (50-319112-00) NF694  40x58x8mm, ACM NF692  71x88x8mm, MVQ	NF334 (x2) [38]	 JJ283	

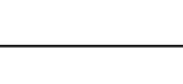

KW/PS

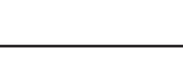

C15 Van 1.1L i		07/88 → 12/96		48				
TU1M (H1A)	1124	4	72.00	Carburettor	40/54	AD5700 (Fibre), 1.25mm [30-026851-00] AD5710 (Fibre), 1.50mm [34] [30-029799-00]	DT010 [21-26851-20/0] DT012▲ [21-26853-20/0]	EH951 [8] [22-25605-00/0] EH952 [22-25605-02/0]
C15 Van 1.3L		07/87 → 05/88		49				
G1A	1294	4	76.50	Carburettor	47/64	BF170 (Fibre), 1.30mm [30-023495-10] BG490 (Fibre), 1.80mm [34]	DF106▲■□○ [21-21887-20/0] DF107▲■	EF102
C15 Van 1.4L		07/87 → 12/96		50				
C15 Van 1.4L E		07/87 → 12/96						
TU3 (K3A)	1360	4	75.00	Carburettor	40-46/ 54-63	AD5700 (Fibre), 1.25mm [30-026851-00] AD5710 (Fibre), 1.50mm [34] [30-029799-00]	DT010 [21-26851-20/0] DT012▲ [21-26853-20/0]	EH951 [8] [22-25605-00/0] EH952 [22-25605-02/0]
TU3A (K1H)	1360	4	75.00	Carburettor	47-49/ 64-67			
C15 Van 1.4L E		05/87 → 12/96		51				
XY7 (150D)	1360	4	75.00	Carburettor, SOHC	44/60	BH950 (Fibre), 1.20mm, 1 Notch [33] [30-025152-10] →12/85 BL620 (Fibre), 1.40mm [33] [34] →Eng.3279 BN580 (Fibre), 1.20mm [35] [30-026021-10] Eng.3280 →	DN582▲	EH950 [36]
C15 Van 1.4L i		05/91 → 12/96		52				
TU3FM (KDY)/TU3M (KDY)	1360	4	75.00	SPi, SOHC	55/75	AD5700 (Fibre), 1.25mm [30-026851-00] TU3M BY130 (Fibre), 1.28mm [30-029099-00] AD5710 (Fibre), 1.50mm [34] [30-029799-00] TU3M BY170 (Fibre), 1.50mm [34] TU3FM	DT010 [21-26851-20/0] TU3M DT012▲ [21-26853-20/0] TU3M DY130▲ [21-26853-21/0] TU3FM	EH951 [8] [22-25605-00/0] TU3M EH952 [22-25605-02/0] TU3M EY130 [22-28758-00/0] TU3FM
C15 Van 1.8L D Diesel		07/86 → 12/00		53				
XUD7 (161A)	1769	4	80.00		44/60	BX830 (Fibre), 1.36mm, 1 Notch [30-028484-00] ☞0.56 → 0.67mm BX840 (Fibre), 1.40mm, 2 Notches [30-028485-00] ☞0.68 → 0.71mm BX850 (Fibre), 1.44mm, 3 Notches [30-028486-00] ☞0.72 → 0.75mm BX860 (Fibre), 1.48mm, 4 Notches [30-028487-00] ☞0.76 → 0.79mm BX870 (Fibre), 1.52mm, 5 Notches [30-028488-00] ☞0.80 → 0.83mm	DJ720▲ [21-25202-22/0]	EL890 [22-25198-01/0] GJ720▲ [20-25202-02/0]

								
HBS039 Ⓢ (22-15010B) M10x1.50x175mm (x10)	JC702 Ⓢ (x2) (31-029804-00) Ⓢ JE189 (31-029805-00)	JN658 (50-026853-00)	JJ586 (31-029806-00) ● PB852 16x24x1.5mm ● PA349 (33-102290-10) 22x16x2mm	HR642 Ⓢ	NF817 36x50x7mm, FPM (50-319112-00) NF870 42x66x6mm, FPM/ACM (50-319113-00) NF857 85x105x9mm, FPM/ACM (50-319478-00)	HL5011 [245]Ⓢ HR564 [37]Ⓢ NF836 [38]Ⓢ NF826 [38]Ⓢ PA850 [13] PA858 [13]		 AD5700, AD5710  JN596  BF170, BG490  JN658  BH950, BL620  HC341  BN580  JJ283  BX830, BX840, BX850, BX860, BX870  JJ586  BY130  JJ587
	JB836 Ⓢ JB837 Ⓢ (31-021888-10)	JN238 (31-021887-00)	HC341 Ⓢ ● PA349 (33-102290-10) 22x16x2mm		NF817 36x50x7mm, FPM (50-319112-00) NF694 40x58x8mm, ACM NF692 71x88x8mm, MVQ			 BX830, BX840, BX850, BX860, BX870  JJ586  BY130  JJ587
HBS039 Ⓢ (22-15010B) M10x1.50x175mm (x10)	JD551 Ⓢ (x2) (31-029803-00) JC702 Ⓢ (x2) (31-029804-00) Ⓢ JE189 (31-029805-00)	JN658 (50-026853-00)	JJ586 (31-029806-00) ● PB852 16x24x1.5mm ● PA349 (33-102290-10) 22x16x2mm	HR642 Ⓢ	NF817 36x50x7mm, FPM (50-319112-00) NF870 42x66x6mm, FPM/ACM (50-319113-00) NF857 85x105x9mm, FPM/ACM (50-319478-00)	HL5011 [245]Ⓢ HR564 [37]Ⓢ NF836 [38]Ⓢ NF826 [38]Ⓢ PA850 [13] PA858 [13]		 BY170  JB836  JB837  JC135  JC423  JC702  JD551  JE189  JN238  JN544
	JC135 Ⓢ	JN596 (50-023671-00)	● PA349 (33-102290-10) 22x16x2mm	HR300 Ⓢ HR569 Ⓢ 24-30667-00/0	NF678 35x50x8mm, ACM NF641 78x100x10mm, MVQ	HR564 [37]Ⓢ NF526 (x2) [2]Ⓢ HL442 [39] [41]Ⓢ		 BY170  JB836  JB837  JC135  JC423  JC702  JD551  JE189  JN238  JN544
HBS039 Ⓢ (22-15010B) M10x1.50x175mm (x10)	JD551 Ⓢ (x2) (31-029803-00) JC702 Ⓢ (x2) (31-029804-00) Ⓢ JE189 (31-029805-00)	JN658 (50-026853-00)	JJ586 (31-029806-00) TU3M JJ587 TU3FM ● PB852 16x24x1.5mm ● PA349 (33-102290-10) 22x16x2mm	HR642 Ⓢ	NF817 36x50x7mm, FPM (50-319112-00) NF870 42x66x6mm, FPM/ACM (50-319113-00) NF857 85x105x9mm, FPM/ACM (50-319478-00)	HL5011 [245]Ⓢ HR564 [37]Ⓢ NF836 [38]Ⓢ NF826 [38]Ⓢ PA850 [13] TU3M PA858 [13]		 JC135  JC423  JC702  JD551  JE189  JN238  JN544
HBS084 Ⓢ (22-15005B) M12x1.50x123mm (x10) → Eng.08469 HBS245 Ⓢ (22-53008B) M12x1.50x125mm (x10) Eng.08470 →	JC423 Ⓢ (x2) (31-025199-10)	JN544 (50-025202-00)	JJ283 [6] (31-025198-10) ● PA349 (33-102290-10) 22x16x2mm	HR569 Ⓢ 24-30667-00/0	NF841 35x50x8mm, FPM (50-319310-00) NA5191 42x62x7mm, PTFE (50-319500-00) NA5192 90x110x7mm, PTFE (50-319501-00)	HL5010 [245]Ⓢ NF836 [38]Ⓢ NF826 [38]Ⓢ KA611 [13]		 JC423  JC702  JD551  JE189  JN238  JN544



KWPS



C15 Van 1.9L D Diesel				12/00 →	54			CA5830▲
	1868	4			44/60	AA5830 (Steel Elastomer), 1.26mm, 1 Hole (30-029190-00) ☞0.51→0.54mm AA5840 (Steel Elastomer), 1.30mm, 2 Holes (30-029191-00) ☞0.55→0.58mm AA5850 (Steel Elastomer), 1.34mm, 3 Holes (30-029192-00) ☞0.59→0.62mm AA5860 (Steel Elastomer), 1.38mm, 4 Holes (30-029193-00) ☞0.63→0.66mm AA5870 (Steel Elastomer), 1.42mm, 5 Holes (30-029194-00) ☞0.67→0.70mm AA5880 (Steel Elastomer), 1.46mm, 6 Holes (30-029195-00) ☞0.71→0.75mm		(21-29482-20/0)
C2 1.1L				09/03 →	55			CC5700
TU1JP (HFV)	1124	4	72.00	MPi, SOHC	44/60	AC5700 (Fibre), 1.26mm (30-029572-00)		EC5700 (21-29572-20/0)
C2 1.4L				09/03 →	56			DT012▲
TU3JP-L4	1360	4	75.00	MPi, SOHC	55/79	AD5700 (Fibre), 1.25mm (30-026851-00) AD5710 (Fibre), 1.50mm [34] (30-029799-00)		EC5700 EH951 [8] (22-25605-00/0)
C2 1.4L 16V				06/06 →	57			CG9030
ET3J4 (KFU)	1360	4	75.00	Carburettor	65/88	AG9030 (Fibre), 1.4mm (30-030263-00)		EG9030
C2 1.4L HDI Diesel				09/03 →	58			CD5130▲
DV4TD (8HX)	1398	4	73.70	Common Rail, SOHC	52/71	AD5130 (MLS), 1.25mm, 2 Notches, +3 Notches (30-029277-00) AD5140 (MLS), 1.30mm, 3 Notches, +3 Notches (30-029278-00) AD5150 (MLS), 1.35mm, 1 Notch, +3 Notches (30-029279-00) AD5160 (MLS), 1.40mm, +3 Notches, 4 Notches (30-029280-00) AD5170 (MLS), 1.45mm, +3 Notches, 5 Notches (30-029281-00)		ED5130 (21-29277-00/0)
C2 1.6L				09/03 →	59			CD5180
TU5JP4 (NFU/N6A)	1587	4	78.50	SPi	80/109	AD5180 (MLS), 0.62mm (30-029785-00)		ED5180 (21-29785-20/0)
C2 1.6L VTS				01/05 →	60			CD5180
TU5JP4S (NFS)	1587	4	78.50	Carburettor	90/122	AD5180 (MLS), 0.62mm (30-029785-00)		ED5180 (21-29785-20/0)

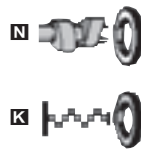
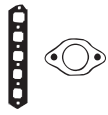

AA5830, AA5840,
AA5850, AA5860,
AA5870, AA5880



AC5700



AD5130, AD5140,
AD5150, AD5160,
AD5170



AD5180



AD5700, AD5710



JC702



JD538



JN658







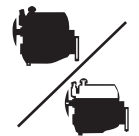



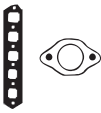

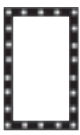

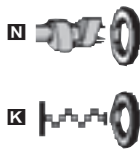



























































<p>HBS084  [22-15005B] M12x1.50x123mm (x10) →Eng.08469 HBS245  [22-53008B] M12x1.50x125mm (x10) Eng.08470→</p>	<p>HA5008   JD5192  (x2)</p>	<p>JM5088  JM5089 </p>	<p>● KG5157 10x20x2mm ● PB907 14x21x2mm</p>	<p>HR569  24-30667-00/0</p>	<p> NB959 35x50x7mm, FPM (50-306644-50)  NA5191  42x62x7mm, PTFE (50-319500-00)  NA5192  90x110x7mm, PTFE (50-319501-00)</p>	<p>HL5012 [245]  NA5205 [38]  NA5204 [38] </p>
<p>HBS039  [22-15010B] M10x1.50x175mm (x10)</p>	<p>JD5828  HA5028  </p>	<p>JN658 (50-026853-00)</p>	<p>● PB852 16x24x1.5mm ● PA349 (33-102290-10) 22x16x2mm</p>		<p> NF817 36x50x7mm, FPM (50-319112-00)  NF870  42x66x6mm, FPM/ACM (50-319113-00)  NF857  85x105x9mm, FPM/ACM (50-319478-00)</p>	<p>HL5011 [245]  HR564 [37]  PA850 [13]</p>
<p>HBS039  [22-15010B] M10x1.50x175mm (x10)</p>	<p>JD538  (x4) (31-029472-00) JC702  (x2) (31-029804-00)</p>	<p>JN658 (50-026853-00)</p>	<p>● PB852 16x24x1.5mm</p>	<p>HR642 </p>	<p> NF817 36x50x7mm, FPM (50-319112-00)  NF870  42x66x6mm, FPM/ACM (50-319113-00)  NF857  85x105x9mm, FPM/ACM (50-319478-00)</p>	<p>HL5011 [245]  HR564 [37]  NA5205 [38]  NA5204 [38]  PA850 [13]</p>
	<p>JD5882  (FPM)  JE5072 (MLS)</p>	<p>JM7051 JM7052</p>				
<p>HBS359  [22-15018B] M11x1.50x150mm (x10)</p>	<p>HA5029   (24-35042-80/0) JD5829  (31-030265-00)</p>		<p>● KG5157 10x20x2mm</p>		<p> NA5258 27x47x7mm  NA5259  40x55x6.4mm</p>	
<p>HBS254  [22-53009B] M10x1.50x122mm (x10)</p>	<p>HA5032   (24-35043-10/0) JD5831   JE5072 (MLS)</p>	<p>JM7035 (50-030267-00)</p>	<p>JH5107 (ACM) ● PB852 16x24x1.5mm ● PA349 (33-102290-10) 22x16x2mm</p>		<p> NA5260 38x50x6mm  NF870  42x66x6mm, FPM/ACM (50-319113-00)  NF857  85x105x9mm, FPM/ACM (50-319478-00)</p>	<p>HL5038 [245]  NA5205 [38]  NA5204 [38] </p>
<p>HBS254  [22-53009B] M10x1.50x122mm (x10)</p>	<p>HA5032   (24-35043-10/0) JD5831   JE5072 (MLS)</p>	<p>JM7035 (50-030267-00)</p>	<p>JH5107 (ACM) ● PB852 16x24x1.5mm ● PA349 (33-102290-10) 22x16x2mm</p>		<p> NA5260 38x50x6mm  NF870  42x66x6mm, FPM/ACM (50-319113-00)  NF857  85x105x9mm, FPM/ACM (50-319478-00)</p>	<p>HL5038 [245]  NA5205 [38]  NA5204 [38] </p>



KW/PS



C25 1.8 L E						07/87 → 02/94	61		DM533▲	EM531
XM7T (169)	1796	4	84.00	Carburettor, OHV	51/69					
C25 1.9 L D Diesel						07/87 → 02/94	62	BX880 (Fibre), 1.36mm, 1 Notch (30-028475-00) 0.56 → 0.67mm BX890 (Fibre), 1.40mm, 2 Notches (30-028476-00) 0.68 → 0.71mm BX900 (Fibre), 1.44mm, 3 Notches (30-028477-00) 0.72 → 0.75mm BX910 (Fibre), 1.48mm, 4 Notches (30-028478-00) 0.76 → 0.79mm BX920 (Fibre), 1.52mm, 5 Notches (30-028479-00) 0.80 → 0.83mm	DJ720▲ (21-25202-22/0)	EL890 (22-25198-01/0) GJ720▲ (20-25202-02/0)
XUD9A/U (D9B)	1905	4	83.00	SOHC	66/90					
C25 2.0L						02/91 → 03/94	63	BM530 (Fibre), 1.40mm (30-025376-10) BN780 (Fibre), 1.60mm [34]	DM530■ DM533▲	EM531
C25 2.0L E						09/81 → 02/94				
C25 Van 2.0L						02/91 → 03/94				
C25 Van 2.0L E						09/81 → 03/94				
XN1T (170A)/XN1T (170B)	1971	4	88.00	Carburettor, OHV	57/77					
XN1T (170C)	1971	4	88.00	Carburettor	57/77					
C25 2.5 L D Diesel						10/85 → 02/94	64	BG450 (Fibre), 1.35mm (30-025842-10)	DG452▲■ (21-25842-21/0)	GG452○ (20-25842-02/0)
C25 2.5 L D 4x4 Diesel						01/87 → 02/94				
CRD93L (U25/661)	2500	4	93.00	SOHC	54-55/ 73-75					
C25 2.5 L D Turbo Diesel						08/87 → 02/94	65	BL830 (Fibre), 1.80mm (30-026869-10)	DL831▲■	GL830
C25 2.5 L D Turbo 4x4 Diesel						08/87 → 02/94				
CRD93LS (U25/673)	2500	4	93.00		70/95					
C3 1.1 L i						02/02 →	66	AC5700 (Fibre), 1.26mm (30-029572-00)	CC5700 (21-29572-20/0)	EC5700
TU1JP (HFX)	1124	4	72.00	MPi, SOHC	44/60					
C3 1.4L						05/03 →	67	AD5700 (Fibre), 1.25mm (30-026851-00) AD5710 (Fibre), 1.50mm [34] (30-029799-00)	DT012▲ (21-26853-20/0)	EC5700 EH951 [8] (22-25605-00/0)
C3 1.4L i Bivalent						02/02 →				
TU3JP-L4	1360	4	75.00	MPi, SOHC	55/79					
C3 1.4L 16V						12/03 →	68	AG9030 (Fibre), 1.4mm (30-030263-00)	CG9030	EG9030
ET3J4 (KFU)	1360	4	75.00	Carburettor	65/88					

								 AC5700	 JJ283
HBS086  M11x1.50x179mm (x10) 06/85→04/89 HBS038  (22-15003B) M11x1.50x175mm (x10) 04/89→	JB841  (31-018363-10)	JN244	PA349  (33-102290-10) 22x16x2mm	HR569  24-30667-00/0	NA5191  42x62x7mm, PTFE (50-319500-00)	HL472 [37] 	AD5700, AD5710 BG450 BL830 BM530, BN780 BX880, BX890, BX900, BX910, BX920 JB841 JB868 JB869 JC423		
HBS084  (22-15005B) M12x1.50x123mm (x10)	JC759 [60] (31-028417-00) (Steel) JC423  (x2) (31-025199-10)	JN544 (50-025202-00)	JJ283 [6] (31-025198-10) PA349  (33-102290-10) 22x16x2mm	HR569  24-30667-00/0	NF841  35x50x8mm, FPM (50-319310-00) NA5191  42x62x7mm, PTFE (50-319500-00) NA5192  90x110x7mm, PTFE (50-319501-00)	HL5010 [245]  NF836 [38]  NF826 [38]  KA611 [13]	BM530, BN780 BX880, BX890, BX900, BX910, BX920 JB841 JB868 JB869 JC423		
HBS086  M11x1.50x179mm (x10) 06/85→04/89 HBS038  (22-15003B) M11x1.50x175mm (x10) 04/89→	JB841  (31-018363-10)	JN244	PA349  (33-102290-10) 22x16x2mm	HR569  24-30667-00/0	NA5191  42x62x7mm, PTFE (50-319500-00)	HL472 [37] 	JB841 JB868 JB869 JC423		
HBS017  (22-15008B) M12x1.50x145mm (x8) M12x1.50x118mm (x9)	JB868  (x4) JB869  (x4)	JN426	PA349  (33-102290-10) 22x16x2mm	HR340 	NF741  29x46x10mm, ACM NF776  75x90x11.5mm, FPM/ACM NF752  95x112x12.5mm, FPM	HL5022 [245]  NF778 [70] FPM/ACM NF554 [42]	JC702 JC759		
HBS017  (22-15008B) M12x1.50x145mm (x8) M12x1.50x118mm (x9)	JB868  (x4) JB869  (x4)	JN426	PA349  (33-102290-10) 22x16x2mm	HR340 	NF741  29x46x10mm, ACM NF752  95x112x12.5mm, FPM	NF554 [42]	JC759		
HBS039  (22-15010B) M10x1.50x175mm (x10)	JD5828  HA5028  	JN658 (50-026853-00)	PB852  16x24x1.5mm PA349  (33-102290-10) 22x16x2mm		NF817  36x50x7mm, FPM (50-319112-00) NF870  42x66x6mm, FPM/ACM (50-319113-00) NF857  85x105x9mm, FPM/ACM (50-319478-00)	HL5011 [245]  HR564 [37]  PA850 [13]	JN244 JN426 JN544		
HBS039  (22-15010B) M10x1.50x175mm (x10)	JD538  (31-029472-00) JC702  (x2) (31-029804-00)	JN658 (50-026853-00)	PB852  16x24x1.5mm	HR642 	NF817  36x50x7mm, FPM (50-319112-00) NF870  42x66x6mm, FPM/ACM (50-319113-00) NF857  85x105x9mm, FPM/ACM (50-319478-00)	HL5011 [245]  HR564 [37]  NA5205 [38]  NA5204 [38]  PA850 [13]	JN244 JN426 JN544		
	JD5882  (FPM) JD5831   JE5072 (MLS)	JM7051 JM7052					JN658		



KW/PS

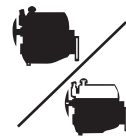

C3 1.4L 16V HDI Diesel 02/02 → 69					AD5130 (MLS), 1.25mm, 2 Notches, +3 Notches (30-029277-00) AD5140 (MLS), 1.30mm, 3 Notches, +3 Notches (30-029278-00) AD5150 (MLS), 1.35mm, 1 Notch, +3 Notches (30-029279-00) AD5160 (MLS), 1.40mm, +3 Notches, 4 Notches (30-029280-00) AD5170 (MLS), 1.45mm, +3 Notches, 5 Notches (30-029281-00)	CD5140▲ (21-29278-00/0)	ED5130
DV4TED4 (8HY)	1398	4	73.70	Common Rail, DOHC			
C3 1.4L HDI Diesel 02/02 → 70					AD5130 (MLS), 1.25mm, 2 Notches, +3 Notches (30-029277-00) AD5140 (MLS), 1.30mm, 3 Notches, +3 Notches (30-029278-00) AD5150 (MLS), 1.35mm, 1 Notch, +3 Notches (30-029279-00) AD5160 (MLS), 1.40mm, +3 Notches, 4 Notches (30-029280-00) AD5170 (MLS), 1.45mm, +3 Notches, 5 Notches (30-029281-00)	CD5130▲ (21-29277-00/0)	ED5130
DV4TD (8HX)	1398	4	73.70	Common Rail, SOHC			
C3 1.6L 05/03 → 71					AD5180 (MLS), 0.62mm (30-029785-00)	CD5180 (21-29785-20/0)	ED5180
C3 1.6L 16V 02/02 →							
TU5JP4 (NFU/N6A)	1587	4	78.50	SPi	80/109		
C3 1.6L 16V HDI Diesel 09/05 → 72					AD5130 (MLS), 1.25mm, 2 Notches, +3 Notches (30-029277-00) AD5140 (MLS), 1.30mm, 3 Notches, +3 Notches (30-029278-00) AD5150 (MLS), 1.35mm, 1 Notch, +3 Notches (30-029279-00) AD5160 (MLS), 1.40mm, +3 Notches, 4 Notches (30-029280-00) AD5170 (MLS), 1.45mm, +3 Notches, 5 Notches (30-029281-00)	CD5140▲ (21-29278-00/0)	
C3 16V HDI Diesel 10/05 →							
DV6ATED4 (9HX)	1560	4	75.00	Direct Injection, DOHC	66/90		
DV6TED4	1560	4	75.00	HDi, DOHC	80/109		
C32 2.2LD Diesel 03/74 → 01/80 73					BF600 (Fibre), 1.35mm (30-027847-00)	DG542▲■○	
B22/615 (CRD90)	2175	4	90.00		45/61		
C35 2.5L D Diesel 02/80 → 01/94 74					BG540 (Fibre), 1.35mm (30-027848-00)	DG542▲■○	GG541○
C35 Van 2.5L D Diesel 02/80 → 01/94							
B25/637	2500	4	93.00	OHV	51/69		
C4 1.4L 16V 11/04 → 75					AG9030 (Fibre), 1.4mm (30-030263-00)	CG9030	EG9030
C4 Coupe 1.4L 16V 11/04 →							
ET3J4 (KFU)	1360	4	75.00	Carburettor	65/88		
C4 1.6L 16V Bio-Flex 09/07 → 76					AD5180 (MLS), 0.62mm (30-029785-00)		
TU5JP4 (NFU/N6A)							
TU5JP4 (NFU/N6A)	1587	4	78.50	SPi	80/109		
C4 1.6L 16V 11/04 → 77					AD5180 (MLS), 0.62mm (30-029785-00)	CD5180 (21-29785-20/0)	ED5180
C4 Coupe 1.6L 16V 11/04 →							
TU5JP4 (NFU/N6A)	1587	4	78.50	SPi	80/109		

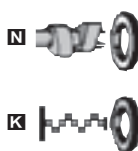
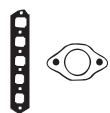

AD5130, AD5140,
AD5150, AD5160,
AD5170



AD5180



BF600



BG540



JB868



JB869



JN253



JN426

HBS359 [22-15018B] M11x1.50x150mm (x10)	JD5830 (50-030266-00) HA5031 [24-35043-00/0] HA5030 [24-35042-90/0] JD5829 (31-030265-00)	JM7034 (50-030264-00)	 KG5157 10x20x2mm		 NA5258 27x47x7mm NA5259 40x55x6.4mm	
HBS359 [22-15018B] M11x1.50x150mm (x10)	HA5029 [24-35042-80/0] JD5829 (31-030265-00)		 KG5157 10x20x2mm		 NA5258 27x47x7mm NA5259 40x55x6.4mm	
HBS254 [22-53009B] M10x1.50x122mm (x10)	HA5032 [24-35043-10/0] JD5831 (MLS)	JM7035 (50-030267-00)	JH5107 (ACM) PB852 16x24x1.5mm PA349 [33-102290-10] 22x16x2mm		 NA5260 38x50x6mm NF870 42x66x6mm, FPM/ACM (50-319113-00) NF857 85x105x9mm, FPM/ACM (50-319478-00)	HL5038 [245] NA5205 [38] NA5204 [38]
HBS359 [22-15018B] M11x1.50x150mm (x10)	JD5830 (50-030266-00) HA5031 [24-35043-00/0] HA5030 [24-35042-90/0] JD5829 (31-030265-00)	JM7034 (50-030264-00)	 KG5157 10x20x2mm		 NA5258 27x47x7mm NA5259 40x55x6.4mm	HL5033 [245]
HBS017 [22-15008B] M12x1.50x145mm (x8) M12x1.50x118mm (x9)	JB868 (x4) JB869 (x4)	JN253	 PA217 16.3x22x2mm	HR340	 NF645 48x65x10mm, MVQ	
HBS017 [22-15008B] M12x1.50x145mm (x8) M12x1.50x118mm (x9)	JB868 (x4) JB869 (x4)	JN253 JN426	 PA217 16.3x22x2mm	HR340	 NF645 48x65x10mm, MVQ	
	JD5882 (FPM) JD5831 (MLS)	JM7051 JM7052				
	 JE5072 (MLS)		JH5107 (ACM)		 NA5260 38x50x6mm	
HBS254 [22-53009B] M10x1.50x122mm (x10)	HA5032 [24-35043-10/0] JD5831 (MLS)	JM7035 (50-030267-00)	JH5107 (ACM) PB852 16x24x1.5mm PA349 [33-102290-10] 22x16x2mm		 NA5260 38x50x6mm NF870 42x66x6mm, FPM/ACM (50-319113-00) NF857 85x105x9mm, FPM/ACM (50-319478-00)	HL5038 [245] NA5205 [38] NA5204 [38]



KW/PS

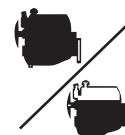

C4 1.6L HDI Diesel					11/04 →	78	AD5130 (MLS), 1.25mm, 2 Notches, +3 Notches (30-029277-00)	CD5140▲ (21-29278-00/0)		
C4 Coupe 1.6L HDI Diesel					11/04 →					
DV6ATED4 (9HX)	1560	4	75.00	Direct Injection, DOHC		66/90	AD5140 (MLS), 1.30mm, 3 Notches, +3 Notches (30-029278-00)			
DV6TED4	1560	4	75.00	HDi, DOHC		80/109				
DV6TED4 (9HY)/ DV6TED4 (9HZ)	1560	4	75.00	Direct Injection, DOHC		80/109				AD5150 (MLS), 1.35mm, 1 Notch, +3 Notches (30-029279-00)
										AD5160 (MLS), 1.40mm, +3 Notches, 4 Notches (30-029280-00)
							AD5170 (MLS), 1.45mm, +3 Notches, 5 Notches (30-029281-00)			
C4 Grand Picasso 1.8 i 16V					10/06 →	79				
C4 Picasso 1.8 i 16V					02/07 →					
EW7A (6FY)	1749	4	82.70	Injection, DOHC						
C4 2.0L 16V					11/04 →	80	AD5300 (MLS)	CD5300	ED5300	
C4 Coupe 2.0L 16V					11/04 →					
EW10A	1997	4	85.00	Injection, DOHC		103/140				
EW10J4S	1997	4	85.00	Injection, DOHC		130/177				
EW10A (RFJ)/ EW10J4S (RFK)	1997	4	85.00	Injection, DOHC						
C4 2.0L 16V					11/04 →	81	AD5300 (MLS)	CD5300	ED5300	
C4 Coupe 2.0L 16V					11/04 →					
EW10J4 (RFN)	1997	4	85.00	MPi, DOHC		100/136				
C4 2.0L HDI Diesel					11/04 →	82	AD5490 (MLS), 1.25mm (30-029789-00)	CD5500▲	ED5500	
C4 Coupe 2.0L HDI Diesel					11/04 →					
DW10BTED4	1997	4	85.00	Direct Injection		100/136	AD5500 (MLS), 1.30mm (30-029790-00)			
DW10BTED4 (RHJ)/ DW10BTED4 (RHR)	1997	4	85.00	Direct Injection, DOHC			AD5510 (MLS), 1.35mm (30-029791-00)			
							AD5520 (MLS), 1.40mm (30-029792-00)			
C5 1.6L HDI Diesel					09/04 →	83	AD5130 (MLS), 1.25mm, 2 Notches, +3 Notches (30-029277-00)	CD5140▲ (21-29278-00/0)		
C5 Coupe 1.6L HDI Diesel					09/04 →					
DV6TED4	1560	4	75.00	HDi, DOHC		80/109	AD5140 (MLS), 1.30mm, 3 Notches, +3 Notches (30-029278-00)			
DV6TED4 (9HY)	1560	4	75.00	Direct Injection, DOHC		80/109	AD5150 (MLS), 1.35mm, 1 Notch, +3 Notches (30-029279-00)			
							AD5160 (MLS), 1.40mm, +3 Notches, 4 Notches (30-029280-00)			
							AD5170 (MLS), 1.45mm, +3 Notches, 5 Notches (30-029281-00)			
C5 1.8L 16V					03/01 → 08/04	84	AD5310 (MLS), 0.75mm	CD5310	ED5300	
C5 Coupe 1.8L 16V					03/01 → 08/04					
EW7J4 (6FZ)	1749	4	82.70	MPi		85/115				
C5 1.8L 16V					09/05 →	85	AD5310 (MLS), 0.75mm		ED5300	
C5 Coupe 1.8L 16V					09/05 →					
EW7A (6FY)	1749	4	82.70	Injection, DOHC						
C5 Break 2.0L HDI Diesel					02/08 →	86	AD5490 (MLS), 1.25mm (30-029789-00)	CD5500▲	ED5500	
C5 2.0L HDI Diesel					09/04 →					
DW10BTED4	1997	4	85.00	Direct Injection		100/136	AD5500 (MLS), 1.30mm (30-029790-00)			
DW10BTED4 (RHR)	1997	4	85.00	Direct Injection, DOHC			AD5510 (MLS), 1.35mm (30-029791-00)			
							AD5520 (MLS), 1.40mm (30-029792-00)			

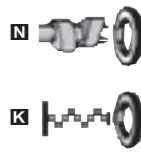
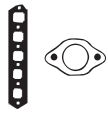

AD5130, AD5140,
AD5150, AD5160,
AD5170



AD5490, AD5500,
AD5510, AD5520

HBS359 (22-15018B) M11x1.50x150mm (x10)	JD5830 (50-030266-00) HA5031 (24-35043-00/0) HA5030 (24-35042-90/0) JD5829 (31-030265-00)	JM7034 (50-030264-00)	KG5157 10x20x2mm		NA5258 27x47x7mm NA5259 40x55x6.4mm	HL5033 [245]
HBS259 (22-53010B) M11x1.50x144.5mm (x10)					NA5256 40x55x6.5mm	
HBS259 (22-53010B) M11x1.50x144.5mm (x10)		JM5283 JM5139	PB907 14x21x2mm		NA5256 40x55x6.5mm	HL5037 [245]
HBS259 (22-53010B) M11x1.50x144.5mm (x10)	JD5833	JM5283 JM5139	PB907 14x21x2mm		NA5256 40x55x6.5mm	HL5037 [245]
HBS261 (22-53014B) M12x1.50x131mm (x10)	JD5881	HM5289	KG5157 10x20x2mm PB907 14x21x2mm	HR5046 (x2)	NA5035 27x47x7mm, FPM (50-319474-00)	
HBS359 (22-15018B) M11x1.50x150mm (x10)	JD5830 (50-030266-00) HA5031 (24-35043-00/0) HA5030 (24-35042-90/0) JD5829 (31-030265-00)	JM7034 (50-030264-00)	KG5157 10x20x2mm		NA5258 27x47x7mm NA5259 40x55x6.4mm	HL5033 [245]
HBS259 (22-53010B) M11x1.50x144.5mm (x10)	JD5833	JM5283 JM5139	PB907 14x21x2mm		NA5256 40x55x6.5mm	
HBS259 (22-53010B) M11x1.50x144.5mm (x10)		JM5283 JM5139	PB907 14x21x2mm		NA5256 40x55x6.5mm	
HBS261 (22-53014B) M12x1.50x131mm (x10)	JD5881	HM5289	KG5157 10x20x2mm PB907 14x21x2mm	HR5046 (x2)	NA5035 27x47x7mm, FPM (50-319474-00) NA5191 42x62x7mm, PTFE (50-319500-00) NA5192 90x110x7mm, PTFE (50-319501-00)	HL5016 [245] NA5205 [38] NA5204 [38]



KW/PS

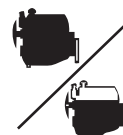

C5 Break 2.0L HDI Diesel						06/01 → 08/04	87	AC5011 (MLS), 1.30mm, 1 Hole ⊖0.47 → 0.605mm	CC5010▲ (21-29484-20/0)	EA5830
C5 2.0L HDI Diesel						06/01 → 08/04		AC5031 (MLS), 1.40mm, 3 Holes (30-029479-10) ⊖0.655 → 0.705mm	CC5011▲ RHZ	
DW10ATED (RHS)	1997	4	85.00	Direct Injection, DOHC	79/107					
DW10ATED (RHZ)	1998	4	85.00	Common Rail	80/109		AC5051 (MLS), 1.50mm, 5 Holes (30-029481-10) ⊖0.755 → 0.83mm			
C5 2.0L 16V						03/01 → 08/04	88	AD5300 (MLS)	CD5300	ED5300
EW10J4 (RFN)	1997	4	85.00	MPi, DOHC	100/136					
C5 2.0L 16V						09/04 →	89	AD5300 (MLS)		ED5300
EW10A	1997	4	85.00	Injection, DOHC	103/140					
C5 2.0L 16V						09/04 →	90	AD5300 (MLS)		ED5300
EW10A (RFJ)	1997	4	85.00	Injection, DOHC						
C5 2.0L 16V HPi						03/01 → 08/04	91	AD5300 (MLS)	CD5300	ED5300
EW10D (RLZ)	1997	4	85.00	Injection, DOHC	103/140					
C5 2.0L HDI Diesel						03/01 → 08/04	92	AC5011 (MLS), 1.30mm, 1 Hole ⊖0.47 → 0.605mm	CC5010▲ (21-29484-20/0)	EA5830
DW10TD (RHY)	1998	4	85.00	Common Rail	63/86		AC5031 (MLS), 1.40mm, 3 Holes (30-029479-10) ⊖0.655 → 0.705mm	CC5011▲ RHZ		
DW10ATED (RHZ)	1998	4	85.00	Common Rail	80/109		AC5051 (MLS), 1.50mm, 5 Holes (30-029481-10) ⊖0.755 → 0.83mm			
C5 2.0L HDI Diesel						09/04 →	93	AD5490 (MLS), 1.25mm (30-029789-00)	CD5500▲	ED5500
DW10BTED4	1997	4	85.00	Direct Injection	100/136		AD5500 (MLS), 1.30mm (30-029790-00)			
							AD5510 (MLS), 1.35mm (30-029791-00)			
							AD5520 (MLS), 1.40mm (30-029792-00)			
C5 2.0L HDI Diesel						03/01 → 08/04	94	AD5490 (MLS), 1.25mm (30-029789-00)		EA5830
DW10ATED (RHS)	1997	4	85.00	Direct Injection, DOHC	79/107		AD5500 (MLS), 1.30mm (30-029790-00)			
DW10ATED (RHZ)	1998	4	85.00	Common Rail	80/109		AD5510 (MLS), 1.35mm (30-029791-00)			
							AD5520 (MLS), 1.40mm (30-029792-00)			
C5 2.2L HDI Diesel						03/01 → 08/04	95	AD5490 (MLS), 1.25mm (30-029789-00)	CD5490▲ (21-29789-20/0)	ED5490 (22-29789-00/0)
DW12TED4/FAP (4HX)	2179	4	85.00	Common Rail	100/136		AD5500 (MLS), 1.30mm (30-029790-00)			
4HT (DW12BTED4)	2179	4	85.00	Direct Injection, DOHC	125/170		AD5510 (MLS), 1.35mm (30-029791-00)			
							AD5520 (MLS), 1.40mm (30-029792-00)			
C5 3.0L V6						03/01 → 08/04	96	AH5060 (MLS), 0.74mm ☒	CH5060☒	
ES9A (XFV)	2946	6	87.00	Injection, DOHC	152/207		AH5070 (MLS), 0.95mm ☒	CH5040☒		
ES9J4S (XFW)	2946	6	87.00	MPi, V6	152/207		AH5040 (MLS), 0.74mm ☒			
							AH5050 (MLS), 0.95mm ☒			

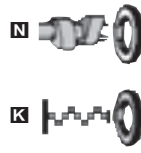
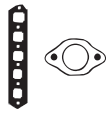

AD5490, AD5500,
AD5510, AD5520

HBS261 (22-53014B) M12x1.50x131mm (x10)	JD5191 JD5190	JM5087 JM5141 (50-030271-00)	● KG5157 10x20x2mm ● PB907 14x21x2mm	HR5046	NA5035 27x47x7mm, FPM (50-319474-00) NA5191 42x62x7mm, PTFE (50-319500-00) NA5192 90x110x7mm, PTFE (50-319501-00)	HL5016 [245] NA5205 [38] NA5204 [38]
HBS259 (22-53010B) M11x1.50x144.5mm (x10)	JD5833	JM5283 JM5139	● PB907 14x21x2mm		NA5256 40x55x6.5mm	HL5037 [245]
HBS259 (22-53010B) M11x1.50x144.5mm (x10)		JM5283 JM5139	● PB907 14x21x2mm		NA5256 40x55x6.5mm	HL5037 [245]
HBS259 (22-53010B) M11x1.50x144.5mm (x10)	JD5833	JM5283 JM5139	● PB907 14x21x2mm		NA5256 40x55x6.5mm	HL5037 [245]
HBS259 (22-53010B) M11x1.50x144.5mm (x10)		JM5283 JM5139	● PB907 14x21x2mm		NA5256 40x55x6.5mm	HL5037 [245]
HBS261 (22-53014B) M12x1.50x131mm (x10)	JD5191 JD5190	JM5087	● KG5157 10x20x2mm ● PB907 14x21x2mm	HR5046	NA5035 27x47x7mm, FPM (50-319474-00) NA5191 42x62x7mm, PTFE (50-319500-00) NA5192 90x110x7mm, PTFE (50-319501-00)	HL5016 [245] NA5205 [38] NA5204 [38]
HBS261 (22-53014B) M12x1.50x131mm (x10)	JD5881	HM5289	● KG5157 10x20x2mm ● PB907 14x21x2mm	HR5046 (x2)	NA5035 27x47x7mm, FPM (50-319474-00)	
HBS261 (22-53014B) M12x1.50x131mm (x10)		JM5141 (50-030271-00)	● KG5157 10x20x2mm ● PB907 14x21x2mm	HR5046 (x2)	NA5035 27x47x7mm, FPM (50-319474-00) NA5191 42x62x7mm, PTFE (50-319500-00) NA5192 90x110x7mm, PTFE (50-319501-00)	HL5016 [245] NA5205 [38] NA5204 [38]
HBS261 (22-53014B) M12x1.50x131mm (x10)		JM5141 (50-030271-00)	● PB907 14x21x2mm	HR5046 (x2)	NA5035 27x47x7mm, FPM (50-319474-00)	
HBS272 (22-53016B) M10x1.50x147mm (x16)	JD5906 JD5907 (x2) JE5069 JE5070 JE5071		● PB852 16x24x1.5mm	HR5062 24-30614-73/0	NA5260 38x50x6mm	



KW/PS



C6 3.0L V6		09/05 →		97		AH5060 (MLS), 0.74mm		CH5060			
ES9J4S	2946	6	87.00	Injection, DOHC			AH5070 (MLS), 0.95mm		CH5040		
							AH5040 (MLS), 0.74mm				
							AH5050 (MLS), 0.95mm				
C8 2.0L 16V		07/02 →		98		AD5300 (MLS)		CD5300		ED5300	
EW10J4 (RFN)	1997	4	85.00	MPI, DOHC	100/136						
C8 2.0L 16V		09/05 →		99		AD5300 (MLS)		CD5300		ED5300	
EW10A (RFJ)	1997	4	85.00	Injection, DOHC							
C8 2.0L HDI Diesel		07/02 →		100		AC5011 (MLS), 1.30mm, 1 Hole →0.47→0.605mm		CC5010▲ (21-29484-20/0)		EA5830	
DW10ATED4 (RHM)/ DW10ATED4 (RHT)	1997	4	85.00	Direct Injection, DOHC	79/107		AC5031 (MLS), 1.40mm, 3 Holes (30-029479-10)		CC5011▲		
DW10ATED4 (RHW)	1997	4	85.00	Direct Injection, DOHC	79-80/ 107- 109		→0.655→0.705mm				
							AC5051 (MLS), 1.50mm, 5 Holes (30-029481-10)				
							→0.755→0.83mm				
C8 2.0L HDI Diesel		03/06 →		101		AD5490 (MLS), 1.25mm (30-029789-00)		CD5500▲		ED5500	
DW10BTED4 (RHR)	1997	4	85.00	Direct Injection, DOHC			AD5500 (MLS), 1.30mm (30-029790-00)				
							AD5510 (MLS), 1.35mm (30-029791-00)				
							AD5520 (MLS), 1.40mm (30-029792-00)				
C8 2.2L		07/02 →		102		AG9750 (MLS)		CG9750		EG9750	
EW12J4 (3FZ)	2230	4	86.00	MPI	116/158						
C8 2.2L HDI Diesel		07/02 →		103		AD5490 (MLS), 1.25mm (30-029789-00)		CD5490▲ (21-29789-20/0)		ED5490 (22-29789-00/0)	
DW12TED4 (4HW)	2179	4	85.00	Direct Injection, DOHC	94/128		AD5500 (MLS), 1.30mm (30-029790-00)				
							AD5510 (MLS), 1.35mm (30-029791-00)				
							AD5520 (MLS), 1.40mm (30-029792-00)				
C8 3.0L V6		07/02 →		104		AH5060 (MLS), 0.74mm		CH5060			
ES9J4S (XFW)	2946	6	87.00	MPI, V6	152/207		AH5070 (MLS), 0.95mm		CH5040		
							AH5040 (MLS), 0.74mm				
							AH5050 (MLS), 0.95mm				
CX 20		08/85 → 08/86		105						GH930 ○	
CX 20 RE		08/85 → 12/92									
CX 2000		06/79 → 08/85									
829.A5	1995	4	88.00	Carburettor	78/106						
CX 22 TRS		07/85 → 12/92		106						GH930 ○	
CX 2200		06/81 → 08/85									
CX 22TRS		07/85 → 07/89									
J6TA	2165	4	88.00	Carburettor	83/85/ 113/ 116						

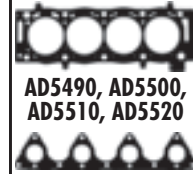
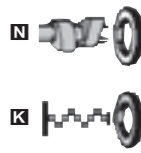
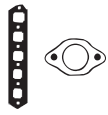

AD5490, AD5500,
AD5510, AD5520

JB954



JN292











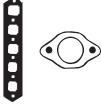

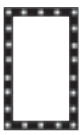

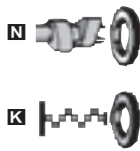

















































HBS272 ⊕ (22-53016B) M10x1.50x147mm (x16)	JD5906 ■ JD5907 ■ (x2) ⊕ JE5069 ⊕ JE5070 ⊕ JE5071		● PB852 16x24x1.5mm	HR5062 ■ 24-30614-73/0	▣ NA5260 38x50x6mm	
HBS259 ⊕ (22-53010B) M11x1.50x144.5mm (x10)	JD5833 ■	JM5283 ■ JM5139 ■	● PB907 14x21x2mm		▣ NA5256 ■ 40x55x6.5mm	
HBS259 ⊕ (22-53010B) M11x1.50x144.5mm (x10)		JM5283 ■ JM5139 ■	● PB907 14x21x2mm		▣ NA5256 ■ 40x55x6.5mm	
HBS261 ⊕ (22-53014B) M12x1.50x131mm (x10)	JD5191 ■ JD5190 ■	JM5087 JM5141 (50-030271-00)	● KG5157 10x20x2mm ● PB907 14x21x2mm	HR5046 ■	▣ NA5035 27x47x7mm, FPM (50-319474-00) ▣ NA5191 ■ 42x62x7mm, PTFE (50-319500-00) ▣ NA5192 ■ 90x110x7mm, PTFE (50-319501-00)	HL5016 [245]■ NA5205 [38]■ NA5204 [38]■
HBS261 ⊕ (22-53014B) M12x1.50x131mm (x10)	JD5881 ■	HM5289 ■	● KG5157 10x20x2mm ● PB907 14x21x2mm	HR5046 ■ (x2)	▣ NA5035 27x47x7mm, FPM (50-319474-00) ▣ NA5191 ■ 42x62x7mm, PTFE (50-319500-00) ▣ NA5192 ■ 90x110x7mm, PTFE (50-319501-00)	HL5016 [245]■ NA5205 [38]■ NA5204 [38]■
HBS309 ⊕ (22-53020B) M11x1.50x128mm (x10)	JD5883 ■ Soft Material Gasket	JM5283 ■ JM5139 ■	● PB907 14x21x2mm		▣ NA5256 ■ 40x55x6.5mm	
HBS261 ⊕ (22-53014B) M12x1.50x131mm (x10)		JM5141 (50-030271-00)	● PB907 14x21x2mm	HR5046 ■ (x2)	▣ NA5035 27x47x7mm, FPM (50-319474-00)	
HBS272 ⊕ (22-53016B) M10x1.50x147mm (x16)	JD5906 ■ JD5907 ■ (x2) ⊕ JE5069 ⊕ JE5070 ⊕ JE5071		● PB852 16x24x1.5mm	HR5062 ■ 24-30614-73/0	▣ NA5260 38x50x6mm	
	JB954 ■	JN292 (50-024771-00)	● PA349 (33-102290-10) 22x16x2mm	HR569 ■ 24-30667-00/0	▣ NF687 35x47x7mm, ACM ▣ NF648 ■ 50x68x10mm, MVQ (50-306251-00) ▣ NF843 ■ 50x68x10mm, FPM/ACM (50-305667-00) ▣ NF844 ■ 90x110x11mm, FPM/ACM	NF849 [15] NF720 [144]
	JB954 ■	JN292 (50-024771-00)	● PA349 (33-102290-10) 22x16x2mm	HR569 ■ 24-30667-00/0	▣ NF687 35x47x7mm, ACM ▣ NF648 ■ 50x68x10mm, MVQ (50-306251-00) ▣ NF844 ■ 90x110x11mm, FPM/ACM	NF849 [15] NF720 [144]



KW/PS



Model					Year Range	Power (KW/PS)	Configuration	Head Type	Head Part	Head Part	
CX 25 D Diesel					08/85 → 12/92	107					
M25/660	2500	4	93.00	SOHC		54/73			BG450 (Fibre), 1.35mm (30-025842-10)	DG452 ▲■ (21-25842-21/0)	GG452 ○ (20-25842-02/0)
CX 25 D Turbo Diesel					04/83 → 12/92	108					
CX 25 D Turbo 2 Diesel					01/87 → 12/92						
CX 2500 D Turbo Diesel					04/83 → 12/86						
M25-648	2500	4	93.00			70/95					
M25/669	2500	4	93.00			88/120			BL830 (Fibre), 1.80mm (30-026869-10)	DL831 ▲■	GL830
CX 25 GTi					05/86 → 12/92	109					
CX 25 i					05/86 → 12/92						
CX 25 TRi					07/83 → 12/92						
M25/668	2498	4	93.00	Injection, OHV		89-98/ 121- 133					
M25/659	2500	4	93.00	SPi, OHV		100/136			BR280 (Fibre), 1.40mm		
CX 25 GTi Turbo 2					06/84 → 12/92	110					
M25/667	2498	4	93.00	OHV		115/156					
M25/662	2500	4	93.00	OHV		122/166					
CX 2500 D Diesel					02/78 → 08/85	111					
M25/629	2500	4	93.00	SOHC		55/75			BG450 (Fibre), 1.35mm (30-025842-10)	DG452 ▲■ (21-25842-21/0)	
Dispatch 1.6L					10/95 →	112					
Dispatch Van 1.6L i					10/95 →						
1580 SPi/220 A2.000	1581	4	86.40	SPi, SOHC		59/80			AY460 (Fibre) [249]	DR630 (21-26294-21/0)	ET400 GR630 (20-26294-01/0)
Dispatch 1.9L D Diesel					10/95 → 04/98	113					
XUD9A/U (D9B)	1905	4	83.00	SOHC		66/90			BX880 (Fibre), 1.36mm, 1 Notch (30-028475-00) -0.56 → 0.67mm	DJ720 ▲ (21-25202-22/0)	EL890 (22-25198-01/0) GJ720 ▲ (20-25202-02/0)
									BX890 (Fibre), 1.40mm, 2 Notches (30-028476-00) -0.68 → 0.71mm		
									BX900 (Fibre), 1.44mm, 3 Notches (30-028477-00) -0.72 → 0.75mm		
									BX910 (Fibre), 1.48mm, 4 Notches (30-028478-00) -0.76 → 0.79mm		
									BX920 (Fibre), 1.52mm, 5 Notches (30-028479-00) -0.80 → 0.83mm		

								
HBS017  (22-15008B) M12x1.50x145mm (x8) M12x1.50x118mm (x9)	JB868  (x4) JB869  (x4) JE651 	JN426	PA217 16.3x22x2mm	HR340 	NF741 29x46x10mm, ACM NF776  75x90x11.5mm, FPM/ACM NF752  95x112x12.5mm, FPM	HL5022 [245]  NF554 [42] NF663 [42] NF778 [144] FPM/ACM		 AY460, BR630  BG450  BL830  BR280  BX880, BX890, BX900, BX910, BX920  JB868  JB869  JC423  JC759  JD146  JE651  JF150  JN234  JN253  JN426  JN544
HBS017  (22-15008B) M12x1.50x145mm (x8) M12x1.50x118mm (x9)	JB868  (x4) JB869  (x4)	JN426	PA217 16.3x22x2mm	HR340 	NF741 29x46x10mm, ACM NF776  75x90x11.5mm, FPM/ACM NF752  95x112x12.5mm, FPM	HL5022 [245]  NF554 [42] NF663 [42] NF778 [144] FPM/ACM		
	JE651 	JN234	PA217 16.3x22x2mm	HR340 	NF741 29x46x10mm, ACM NF752  95x112x12.5mm, FPM			
		JN234	PA217 16.3x22x2mm	HR340 	NF741 29x46x10mm, ACM NF752  95x112x12.5mm, FPM			
HBS017  (22-15008B) M12x1.50x145mm (x8) M12x1.50x118mm (x9)	JB868  (x4) JB869  (x4) JE651 	JN253 JN426	PA217 16.3x22x2mm	HR340 	NF741 29x46x10mm, ACM NF637  48x65x10mm, FPM (50-306222-50)	NF554 [42] NF663 [42]		 JC759  JD146  KA293 [13] KA294 [13] KA354 [13] LA378 [53] KT465 [54] KT754 [11] KT756 [11] LR902 [11] KV122 [56]
HBS051  (22-17001B) M10x1.25x98mm (x5) M10x1.25x84mm (x5)	JD146 (31-027221-10) JF150 (31-027151-00)	JP049 (31-026820-00)	JJ453	HR363 				 JN234  JN253  JN426  JN544
HBS084  (22-15005B) M12x1.50x123mm (x10)	JC759 [60] (31-028417-00) (Steel) JC423  (x2) (31-025199-10)	JN544 (50-025202-00)	JJ283 [6] (31-025198-10) PA349 (33-102290-10) 22x16x2mm PB907 14x21x2mm	HR569  24-30667-00/0	NB959 35x50x7mm, FPM (50-306644-50) NA5191  42x62x7mm, PTFE (50-319500-00) NA5192  90x110x7mm, PTFE (50-319501-00)	HL5012 [245]  NF836 [38]  NF826 [38]  KA611 [13]		



KWPS



Dispatch 1.9L D 70 Diesel		04/98 →		114				
DW8 (WJZ) / DW8B (WJY)	1868	4	82.20	SOHC	51/70	AA5830 (Steel Elastomer), 1.26mm, 1 Hole (30-029190-00) ↳0.51 → 0.54mm AA5840 (Steel Elastomer), 1.30mm, 2 Holes (30-029191-00) ↳0.55 → 0.58mm AA5850 (Steel Elastomer), 1.34mm, 3 Holes (30-029192-00) ↳0.59 → 0.62mm AA5860 (Steel Elastomer), 1.38mm, 4 Holes (30-029193-00) ↳0.63 → 0.66mm AA5870 (Steel Elastomer), 1.42mm, 5 Holes (30-029194-00) ↳0.67 → 0.70mm AA5880 (Steel Elastomer), 1.46mm, 6 Holes (30-029195-00) ↳0.71 → 0.75mm	CA5830▲ (21-29482-20/0)	EA5830
Dispatch 1.9L TD Diesel		10/95 →		115				
XUD9TF (D8B) / XUD9TF/BTF (DHX)	1905	4	83.00	SOHC	66/90	BX930 (Steel Elastomer), 1.36mm, 1 Notch (30-028503-00) BX940 (Steel Elastomer), 1.40mm, 2 Notches (30-028504-00) BX950 (Steel Elastomer), 1.44mm, 3 Notches (30-028505-00) BX960 (Steel Elastomer), 1.48mm, 4 Notches (30-028506-00) BX970 (Steel Elastomer), 1.52mm, 5 Notches (30-028507-00) BX980 (Steel Elastomer), 1.59mm ↳0.83mm →	DJ720▲ (21-25202-22/0)	EL890 (22-25198-01/0) GJ720▲ (20-25202-02/0)
Dispatch 2.0L		04/00 →		116				
EW10J4 (RFN)	1997	4	85.00	MPI, DOHC	100/136	AD5300 (MLS)	CD5300	ED5300
Dispatch 2.0L HDI 110 Diesel		03/00 →		117				
DW10ATED (RHZ)	1998	4	85.00	Common Rail	80/109	AC5011 (MLS), 1.30mm, 1 Hole ↳0.47 → 0.605mm AC5031 (MLS), 1.40mm, 3 Holes (30-029479-10) ↳0.655 → 0.705mm AC5051 (MLS), 1.50mm, 5 Holes (30-029481-10) ↳0.755 → 0.83mm	CC5010▲ (21-29484-20/0) → Eng.8331 CC5011▲ Eng.8332 →	EA5830
Dispatch 2.0L HDI 110 Diesel		01/02 →		118				
DW10ATED (RHZ)	1998	4	85.00	Common Rail	80/109	AC5011 (MLS), 1.30mm, 1 Hole ↳0.47 → 0.605mm AC5031 (MLS), 1.40mm, 3 Holes (30-029479-10) ↳0.655 → 0.705mm AC5051 (MLS), 1.50mm, 5 Holes (30-029481-10) ↳0.755 → 0.83mm	CC5010▲ (21-29484-20/0) → Eng.8331 CC5011▲ Eng.8332 →	EA5830
Dispatch 2.0L HDI 95 Diesel		10/99 →		119				
DW10BTED (RHX)	1997	4	85.00	Direct Injection	69/93	AC5011 (MLS), 1.30mm, 1 Hole ↳0.47 → 0.605mm AC5031 (MLS), 1.40mm, 3 Holes (30-029479-10) ↳0.655 → 0.705mm AC5051 (MLS), 1.50mm, 5 Holes (30-029481-10) ↳0.755 → 0.83mm	CC5010▲ (21-29484-20/0)	EA5830
Dispatch 2.0L i 16V		03/00 →		120				
Dispatch Van 2.0L i 16V	1997	4			102/138	AD5300 (MLS)	CD5300	ED5300

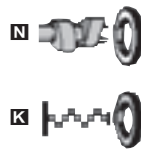
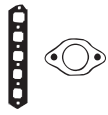

AA5830, AA5840,
AA5850, AA5860,
AA5870, AA5880



BX930, BX940,
BX950, BX960,
BX970, BX980



JC759



JC991



JN544



JJ283











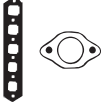

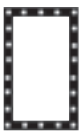

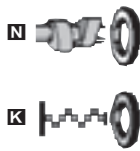

<p>HBS084 [22-15005B] M12x1.50x123mm (x10) →Eng.08469</p> <p>HBS245 [22-53008B] M12x1.50x125mm (x10) Eng.08470→</p>	<p>HA5008 [1] JD5192 [x2]</p>	<p>JM5088 JM5089</p>	<p>● KG5157 10x20x2mm</p> <p>● PB907 14x21x2mm</p>	<p>HR569 [24-30667-00/0]</p>	<p>▣ NB959 35x50x7mm, FPM (50-306644-50)</p> <p>▣ NA5191 42x62x7mm, PTFE (50-319500-00)</p> <p>▣ NA5192 90x110x7mm, PTFE (50-319501-00)</p>	<p>HL5012 [245] NA5205 [38] NA5204 [38]</p>
<p>HBS088 [22-15014B] M12x1.50x145mm (x10) →Eng.08574</p> <p>HBS277 [22-53018B] M12x1.50x148mm (x10) Eng.08575→</p>	<p>JC759 [60] (31-028417-00) (Steel)</p> <p>JC991 (31-028595-00)</p>	<p>JN544 (50-025202-00)</p>	<p>JJ283 [6] (31-025198-10)</p> <p>● PA349 (33-102290-10) 22x16x2mm</p> <p>● PB907 14x21x2mm</p>	<p>HR569 [24-30667-00/0]</p>	<p>▣ NF841 35x50x8mm, FPM (50-319310-00) →Eng.06265</p> <p>▣ NB959 35x50x7mm, FPM (50-306644-50) Eng.06265→</p> <p>▣ NA5191 42x62x7mm, PTFE (50-319500-00)</p> <p>▣ NA5192 90x110x7mm, PTFE (50-319501-00)</p>	<p>HL5010 [245] HL5012 [245] NF824 [38] Evasion,Jumper,Jumpy</p> <p>NF825 [38] Evasion,Jumper,Jumpy</p> <p>KA611 [13]</p>
<p>HBS259 [22-53010B] M11x1.50x144.5mm (x10)</p>	<p>JD5833</p>	<p>JM5283 JM5139</p>	<p>● PB907 14x21x2mm</p>		<p>▣ NA5256 40x55x6.5mm</p>	
<p>HBS261 [22-53014B] M12x1.50x131mm (x10)</p>	<p>JD5191 JD5190</p>	<p>JM5087</p>	<p>● KG5157 10x20x2mm</p> <p>● PB907 14x21x2mm</p>	<p>HR5046</p>	<p>▣ NA5035 27x47x7mm, FPM (50-319474-00)</p> <p>▣ NA5191 42x62x7mm, PTFE (50-319500-00)</p> <p>▣ NA5192 90x110x7mm, PTFE (50-319501-00)</p>	<p>HL5016 [245] NA5205 [38] NA5204 [38]</p>
<p>HBS261 [22-53014B] M12x1.50x131mm (x10)</p>	<p>JD5191 JD5190</p>	<p>JM5087</p>	<p>● KG5157 10x20x2mm</p> <p>● PB907 14x21x2mm</p>	<p>HR5046</p>	<p>▣ NA5035 27x47x7mm, FPM (50-319474-00)</p> <p>▣ NA5191 42x62x7mm, PTFE (50-319500-00)</p> <p>▣ NA5192 90x110x7mm, PTFE (50-319501-00)</p>	<p>HL5016 [245] NA5205 [38] NA5204 [38]</p>
<p>HBS261 [22-53014B] M12x1.50x131mm (x10)</p>	<p>JD5191 JD5190</p>	<p>JM5087</p>	<p>● KG5157 10x20x2mm</p> <p>● PB907 14x21x2mm</p>	<p>HR5046</p>	<p>▣ NA5035 27x47x7mm, FPM (50-319474-00)</p> <p>▣ NA5191 42x62x7mm, PTFE (50-319500-00)</p> <p>▣ NA5192 90x110x7mm, PTFE (50-319501-00)</p>	<p>HL5016 [245] NA5205 [38] NA5204 [38]</p>
<p>HBS259 [22-53010B] M11x1.50x144.5mm (x10)</p>	<p>JD5833</p>	<p>JM5283 JM5139</p>	<p>● PB907 14x21x2mm</p>			



KW/PS



Dyane 6					12/68 → 10/84	121		DF050▲■○	GF051▲○ [12] (20-22547-03/0)
M28 (AM2)/M28/1 (AK2)	602	2	74.00	Carburettor, OHV		21/29			
Evasion 1.8L					05/97 → 07/02	122	BL650 (Fibre), 1.20mm (30-026859-10) BR510 (Fibre), 1.44mm [34] (30-026858-10)	CY131▲ (21-25204-24/0) Evasion Only	EL650 (22-25198-00/0)
XU7JP (LFW/LFZ/L6A)	1761	4	83.00	MPi		73/99			
Evasion 1.9L TD Diesel					11/94 → 07/02	123	BX930 (Steel Elastomer), 1.36mm, 1 Notch (30-028503-00) BX940 (Steel Elastomer), 1.40mm, 2 Notches (30-028504-00) BX950 (Steel Elastomer), 1.44mm, 3 Notches (30-028505-00) BX960 (Steel Elastomer), 1.48mm, 4 Notches (30-028506-00) BX970 (Steel Elastomer), 1.52mm, 5 Notches (30-028507-00) BX980 (Steel Elastomer), 1.59mm →0.83mm →	DJ720▲ (21-25202-22/0)	EL890 (22-25198-01/0) GJ720▲ (20-25202-02/0)
XUD9TF (D8B)/ XUD9TF/BTF (DHX)	1905	4	83.00	SOHC		66/90			
Evasion 2.0L					06/94 → 07/02	124	BV140 (Fibre), 1.25mm (30-028760-00) BY320 (Fibre), 1.45mm [34]	CY082▲ (21-25204-23/0)	ES820 (22-25198-03/0)
XU10J2 (RFU)	1998	4	86.00	MPi		89/121			
Evasion 2.0L 16V					05/98 → 04/00	125	AY070 (Fibre) (30-029744-00)		
XU10J4R (RFV)	1998	4	86.00	MPi		99/135			
Evasion 2.0L 16V					05/00 → 07/02	126	AD5300 (MLS)	CD5300	ED5300
EW10J4 (RFN)	1997	4	85.00	MPi, DOHC		100/136			
Evasion 2.0L HDI Diesel					08/99 → 07/02	127	AC5011 (MLS), 1.30mm, 1 Hole →0.47 → 0.605mm AC5031 (MLS), 1.40mm, 3 Holes (30-029479-10) →0.655 → 0.705mm AC5051 (MLS), 1.50mm, 5 Holes (30-029481-10) →0.755 → 0.83mm	CC5010▲ (21-29484-20/0) →Eng.8331 CC5011▲ Eng.8332 →	EA5830
DW10ATED (RHZ)	1998	4	85.00	Common Rail		80/109			
Evasion 2.0L TD Diesel					05/97 → 07/02	128	AC5011 (MLS), 1.30mm, 1 Hole →0.47 → 0.605mm AC5031 (MLS), 1.40mm, 3 Holes (30-029479-10) →0.655 → 0.705mm AC5051 (MLS), 1.50mm, 5 Holes (30-029481-10) →0.755 → 0.83mm	CC5010▲ (21-29484-20/0) →Eng.8331 CC5011▲ Eng.8332 →	
	1998	4				68/92			

								 AY070	 BL650	 BV140, BY320	 BX930, BX940, BX950, BX960, BX970, BX980
		JB864 (x2) JB830 (x2)	JN232 (x2)	PA217 16.3x22x2mm		NF812 30x42x8mm, ACM (50-319440-00) NF747 55.5x69x10mm, ACM NF809 56x69x10mm, FPM/ACM	NF036 (x6) [2] NF505 (x2) [38] LT639 (x2) [119] NF577 (x8) [141]				
HBS260 (22-53011B) M12x1.50x168mm (x10)	JD519 (x2) JC415 (x4) (31-025205-20)	JN547 (50-025204-10)	JJ283 [6] (31-025198-10) PB907 14x21x2mm	HR569 24-30667-00/0	NF817 36x50x7mm, FPM (50-319112-00) NA5191 42x62x7mm, PTFE (50-319500-00) NA5192 90x110x7mm, PTFE (50-319501-00)	HL5019 [245] HR566 [37] NA5205 [38] NA5204 [38] KA611 [13]					 HA510
HBS088 (22-15014B) M12x1.50x145mm (x10) →Eng.08574 HBS277 (22-53018B) M12x1.50x148mm (x10) Eng.08575→	JC759 [60] (31-028417-00) (Steel)	JN544 (50-025202-00)	JJ283 [6] (31-025198-10) PA349 (33-102290-10) 22x16x2mm PB907 14x21x2mm	HR569 24-30667-00/0	NF841 35x50x8mm, FPM (50-319310-00) →Eng.06264 NB959 35x50x7mm, FPM (50-306644-50) Eng.06265→ NA5191 42x62x7mm, PTFE (50-319500-00) NA5192 90x110x7mm, PTFE (50-319501-00)	HL5010 [245] HL5012 [245] NF824 [38] NF825 [38] KA611 [13]					 JB830
HBS084 (22-15005B) M12x1.50x123mm (x10)	HA510 (x4) JC415 (x4) (31-025205-20)	JN547 (50-025204-10)	JJ283 [6] (31-025198-10) PA349 (33-102290-10) 22x16x2mm PB907 14x21x2mm	HR569 24-30667-00/0	NF817 36x50x7mm, FPM (50-319112-00) NA5191 42x62x7mm, PTFE (50-319500-00) NA5192 90x110x7mm, PTFE (50-319501-00)	HL5019 [245] NA5205 [38] NA5204 [38] KA611 [13]					 JB864
HBS087 (22-15013B) M12x1.50x110mm (x10) →Eng.08581 HBS278 (22-53019B) M12x1.50x110mm (x10) Eng.08582→			PB907 14x21x2mm	HR5080 (24-30710-45/0) →Eng.07359 HR5081 (24-30721-87/0) Eng.07360→ →Eng.07965	NF817 36x50x7mm, FPM (50-319112-00) NA5191 42x62x7mm, PTFE (50-319500-00) NA5192 90x110x7mm, PTFE (50-319501-00)	HL5019 [245] NA5205 [38] NA5204 [38] KA611 [13]					 JC415
HBS259 (22-53010B) M11x1.50x144.5mm (x10)	JD5833	JM5283 JM5139	PB907 14x21x2mm		NA5256 40x55x6.5mm						 JC759
HBS261 (22-53014B) M12x1.50x131mm (x10)	JD5191 JD5190	JM5087	KG5157 10x20x2mm PB907 14x21x2mm	HR5046	NA5035 27x47x7mm, FPM (50-319474-00) NA5191 42x62x7mm, PTFE (50-319500-00) NA5192 90x110x7mm, PTFE (50-319501-00)	HL5016 [245] NA5205 [38] NA5204 [38]					 JD519
HBS261 (22-53014B) M12x1.50x131mm (x10)	JD5191 JD5190	JM5087	KG5157 10x20x2mm PB907 14x21x2mm	HR5046	NA5035 27x47x7mm, FPM (50-319474-00) NA5191 42x62x7mm, PTFE (50-319500-00) NA5192 90x110x7mm, PTFE (50-319501-00)	HL5016 [245] NA5205 [38] NA5204 [38]					 JN232



JN544

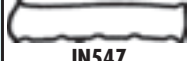

JN547









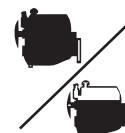



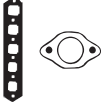

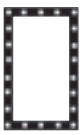

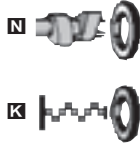







































































JJ283



KW/PS



Evasion 2.0L Turbo C.T.					06/94 → 07/02	129	BY310 (Fibre), 1.25mm (30-028761-00) BY320 (Fibre), 1.45mm [34]		DY310▲ (21-25204-25/0)	ES820 (22-25198-03/0)
XU10J2TE (RGX)	1998	4	86.00	SOHC		108/147				
Evasion 2.1L TD Diesel					05/96 → 07/02	130	BY941 (MLS), 1.52mm (30-027543-20) → 0.65 → 0.76mm BY961 (MLS), 1.62mm (30-028712-10) → 0.82 → 0.86mm BY981 (MLS), 1.72mm (30-028714-10) → 0.92 → 0.96mm		DV150▲ (21-27540-20/0)	EV150 (22-25198-02/0)
XUD11BTE (P8C)	2088	4	85.00			81/110				
Jumper 1.9L D Diesel					02/94 → 04/02	131	BX880 (Fibre), 1.36mm, 1 Notch (30-028475-00) → 0.56 → 0.67mm BX890 (Fibre), 1.40mm, 2 Notches (30-028476-00) → 0.68 → 0.71mm BX900 (Fibre), 1.44mm, 3 Notches (30-028477-00) → 0.72 → 0.75mm BX910 (Fibre), 1.48mm, 4 Notches (30-028478-00) → 0.76 → 0.79mm BX920 (Fibre), 1.52mm, 5 Notches (30-028479-00) → 0.80 → 0.83mm		DJ720▲ (21-25202-22/0)	EL890 (22-25198-01/0) GJ720▲ (20-25202-02/0)
XUD9A (DJY/D9B)	1905	4	83.00			51/70				
XUD9A/U (D9B)	1905	4	83.00	SOHC		66/90				
Jumper 1.9L TD Diesel					02/94 → 04/02	132	BX930 (Steel Elastomer), 1.36mm, 1 Notch (30-028503-00) BX940 (Steel Elastomer), 1.40mm, 2 Notches (30-028504-00) BX950 (Steel Elastomer), 1.44mm, 3 Notches (30-028505-00) BX960 (Steel Elastomer), 1.48mm, 4 Notches (30-028506-00) BX970 (Steel Elastomer), 1.52mm, 5 Notches (30-028507-00) BX980 (Steel Elastomer), 1.59mm → 0.83mm →		DJ720▲ (21-25202-22/0)	EL890 (22-25198-01/0) GJ720▲ (20-25202-02/0)
Jumper 1.9L TD 4x4 Diesel					08/96 → 04/02					
XUD9TE/BTF (DHX)	1905	4	83.00	SOHC		66/90				
XUD9TE (D8C/DHX)	1905	4	83.00			68/92				
Jumper 2.0L					02/94 → 04/02	133	BV140 (Fibre), 1.25mm (30-028760-00) BY320 (Fibre), 1.45mm [34]		CY081▲	ES820 (22-25198-03/0)
Jumper 2.0L 4x4					08/96 → 04/02					
Jumper 2.0L i Bivalent					02/03 →					
Jumper Box 2.0L					03/94 → 04/02					
XU10J2 (RFW)	1998	4	86.00	MPi		80/109				
XU10J2	1998	4	86.00	MPi		89/121				
Jumper 2.0L HDI Diesel					11/01 → 04/02	134	AC5011 (MLS), 1.30mm, 1 Hole → 0.47 → 0.605mm AC5031 (MLS), 1.40mm, 3 Holes (30-029479-10) → 0.655 → 0.705mm AC5051 (MLS), 1.50mm, 5 Holes (30-029481-10) → 0.755 → 0.83mm		CC5010▲ (21-29484-20/0)	EA5830
DW10UTD (RHV)	1997	4	85.00	Direct Injection		62/84				











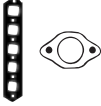

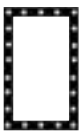



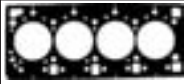





































































								
HBS084  (22-15005B) M12x1.50x123mm (x10)	HA512  	JN547 (50-025204-10)	JJ283 [6] (31-025198-10) ● PB907 14x21x2mm	HR569  24-30667-00/0	NF817  36x50x7mm, FPM (50-319112-00) NA5191  42x62x7mm, PTFE (50-319500-00) NA5192  90x110x7mm, PTFE (50-319501-00)	HL5019 [245]  NF824 [38]  NF825 [38]  KA611 [13]	 BX880, BX890, BX900, BX910, BX920	
HBS125  (22-15007B) M12x1.50x150.5mm (x10)	JD529  (31-027540-00) JD230 	JP045 (50-028922-00)	● PB907 14x21x2mm	HR805 	NF841  35x50x8mm, FPM (50-319310-00) NA5191  42x62x7mm, PTFE (50-319500-00) NA5192  90x110x7mm, PTFE (50-319501-00)	HL5010 [245]  NF824 [38]  NF825 [38]  KA611 [13]	 BX930, BX940, BX950, BX960, BX970, BX980  BY310, BY320, BV140  HA512  JC415  JC423  JC759  JC991  JD230  JD519  JD529 	
HBS084  (22-15005B) M12x1.50x123mm (x10)	JC759 [60] (31-028417-00) (Steel) JC423  (x2) (31-025199-10)	JN544 (50-025202-00)	JJ283 [6] (31-025198-10) ● PA349 (33-102290-10) 22x16x2mm	HR569  24-30667-00/0	NB959  35x50x7mm, FPM (50-306644-50) NA5191  42x62x7mm, PTFE (50-319500-00) NA5192  90x110x7mm, PTFE (50-319501-00)	HL5012 [245]  NF824 [38]  NF825 [38]  KA611 [13]	 JN544  JN547  JP045  JJ283	
HBS088  (22-15014B) M12x1.50x145mm (x10) → Eng.08574 HBS277  (22-53018B) M12x1.50x148mm (x10) Eng.08575 →	JC991 (31-028595-00)	JN544 (50-025202-00)	JJ283 [6] (31-025198-10) ● PA349 (33-102290-10) 22x16x2mm ● PB907 14x21x2mm	HR569  24-30667-00/0	NF841  35x50x8mm, FPM (50-319310-00) → Eng.06265 NB959  35x50x7mm, FPM (50-306644-50) Eng.06265 → NA5191  42x62x7mm, PTFE (50-319500-00) NA5192  90x110x7mm, PTFE (50-319501-00)	HL5010 [245]  HL5012 [245]  NF824 [38]  Evasion, Jumper, Jumpy NF825 [38]  Evasion, Jumper, Jumpy KA611 [13]	 JN544  JN547  JP045 	
HBS245  (22-53008B) M12x1.50x125mm (x10)	JD519  (x2) JC415  (x4) (31-025205-20)	JN547 (50-025204-10)	JJ283 [6] (31-025198-10) ● PA349 (33-102290-10) 22x16x2mm ● PB907 14x21x2mm	HR569  24-30667-00/0	NF817  36x50x7mm, FPM (50-319112-00) NA5191  42x62x7mm, PTFE (50-319500-00) NA5192  90x110x7mm, PTFE (50-319501-00)	HL5019 [245]  NF824 [38]  NF825 [38]  KA611 [13]		
HBS261  (22-53014B) M12x1.50x131mm (x10)	JD5191  JD5190 	JM5087	● KG5157 10x20x2mm ● PB907 14x21x2mm	HR5046 	NA5035  27x47x7mm, FPM (50-319474-00) NA5191  42x62x7mm, PTFE (50-319500-00) NA5192  90x110x7mm, PTFE (50-319501-00)	HL5016 [245]  NA5205 [38]  NA5204 [38] 		



KW/PS



Jumper 2.0L i				02/94 →	135	BS820 (Fibre), 1.25mm (30-027556-00)	DS820▲ (21-25204-22/0)	ES820 (22-25198-03/0)
XU102C (R2A)	1998	4	86.00	Injection, SOHC	79/107			
Jumper 2.2L HDI Diesel				04/02 →	136	AH5080 (MLS), 1.25mm, 1 Hole AH5090 (MLS), 1.30mm, 2 Holes AH5100 (MLS), 1.35mm, 3 Holes AH5110 (MLS), 1.40mm, 4 Holes		
DW12TED (4HY)	2179	4	85.00	Common Rail	74/100			
Jumper 2.5L D Diesel				03/94 →04/02	137	BY140 (Fibre) (30-029752-00)	DY140▲ (21-29752-20/0)	EY140 (22-29752-00/0)
Jumper 2.5L D 4x4 Diesel				08/96 →04/02				
Jumper 2.5L TDi 4x4 Diesel				03/00 →04/02				
DJ5 (T9A)	2446	4	92.00	SOHC	63/86			
Jumper 2.5L TD Diesel				03/94 →04/02	138	BY140 (Fibre) (30-029752-00)	DY140▲ (21-29752-20/0)	EY140 (22-29752-00/0)
Jumper 2.5L TD 4x4 Diesel				08/96 →04/02				
DJ5T (T8A)	2446	4	92.00	SOHC	76/103			
Jumper 2.5L TDi Diesel				12/96 →04/02	139	AE5050 (MLS) (30-029793-00)	CE5050▲ (21-29793-20/0)	
Jumper 2.5L TDi 4x4 Diesel				12/96 →04/02				
DJ5TED (THX)	2446	4	92.00	SOHC	79/107			
Jumper 2.8L D Diesel				01/99 →	140	AY680 (Fibre), 1.60mm (30-028607-00) AY690 (Fibre), 1.70mm (30-028608-00) AY700 (Fibre), 1.80mm (30-028609-00)	CY680▲ (21-28607-20/0)	FY691▲ [147] (20-28607-01/0)
8140.63	2798	4	94.40	Sofim	64/87			
Jumper 2.8L HDI Diesel				09/00 →04/02	141	BX390 (Fibre), 1.20mm [71] (30-027867-00) BX400 (Fibre), 1.30mm [71] (30-027868-00) BX410 (Fibre), 1.40mm [71] (30-027883-00) BX420 (Fibre), 1.50mm [71] (30-027884-00)	DX392▲ (21-27867-22/0)	GX392▲ (20-27867-02/0)
Jumper 2.8L HDI 4x4 Diesel				09/00 →04/02				
Jumper Box 2.8L HDI Diesel				04/02 →				
Jumper Box 2.8L HDI 4x4 Diesel				04/02 →				
8140.43S	2798	4	94.40	Common Rail	92/125			
Jumper 2.8L HDI Diesel				05/04 →	142	BX390 (Fibre), 1.20mm [71] (30-027867-00) BX400 (Fibre), 1.30mm [71] (30-027868-00) BX410 (Fibre), 1.40mm [71] (30-027883-00) BX420 (Fibre), 1.50mm [71] (30-027884-00)	DX400▲ (21-27867-23/0)	GX390▲ (20-27867-00/0)
8140.43N	2798	4	94.40	Direct Injection	107/146			











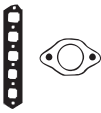

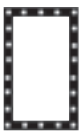

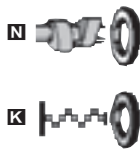

































































								 AE5050
HBS084  [22-15005B] M12x1.50x123mm (x10)	JC415  [31-025205-20]	JN547 [50-025204-10]	JJ283 [6] [31-025198-10] = PA349 [33-102290-10] 22x16x2mm = PB907 14x21x2mm	HR569  24-30667-00/0	NF817 36x50x7mm, FPM [50-319112-00] NA5191  42x62x7mm, PTFE [50-319500-00] NA5192  90x110x7mm, PTFE [50-319501-00]	HL5019 [245]  NF825 [38] NF824 [38]  KA611 [13]	 AY680, AY690, AY700  BS820  BX390, BX400, BX410, BX420	
HBS261  [22-53014B] M12x1.50x131mm (x10)			= PB907 14x21x2mm	HR5046 	NA5035 27x47x7mm, FPM [50-319474-00]		 BY140  JC054  JC055  JC415	
HBS114  [22-15017B] M12x1.50x138mm (x14) M10x1.50x148mm (x8)	JD532  JD531  [31-029755-00]		JJ588 [31-029758-00] = PB852 16x24x1.5mm = PA349 [33-102290-10] 22x16x2mm	HR788 	NB959  35x50x7mm, FPM [50-306644-50] NF866  64x88x6mm, FPM/ACM NF867  98x120x7mm, FPM/ACM	HL5027 [245]  NF824 [38] [146]  NF881 [38] [69]  NF825 [38] [146]  NF882 [38] [69]  KA835 [13]	 JD532  JF123	
HBS114  [22-15017B] M12x1.50x138mm (x14) M10x1.50x148mm (x8)	JD532  JD531  [31-029755-00]		JJ588 [31-029758-00] = PB852 16x24x1.5mm = PA349 [33-102290-10] 22x16x2mm	HR788 	NB959  35x50x7mm, FPM [50-306644-50] NF866  64x88x6mm, FPM/ACM NF867  98x120x7mm, FPM/ACM	HL5027 [245]  NF881 [38] [69]  NF882 [38] [69] 	 JC415  JD532  JF123	
HBS273  [22-53017B] M12x1.50x163mm (x14) M10x1.50x174mm (x8)			= PA349 [33-102290-10] 22x16x2mm	HR642 	NB959 35x50x7mm, FPM [50-306644-50] NF866  64x88x6mm, FPM/ACM NF867  98x120x7mm, FPM/ACM	HL5027 [245]  NF881 [38] [69]  NF882 [38] [69]  KA835 [13]	 JN547  JP069	
HBS255  [22-17021B] M12x1.25x90mm (x8) M12x1.25x160mm (x14)	JC054  [31-024274-10] JC055  [31-025031-10]	JP069	JH5002 JJ519 [31-025623-00]	HR602  24-30670-61/0	NP067  50x70x10mm, FPM [50-307111-70] NF885  [3] 70x159x16mm, FPM [50-307266-70] NF883  [3] 114x171x13mm, FPM [50-307265-70]	JR580 [11] KV927 [46]	 JH5002  JJ283	
HBS255  [22-17021B] M12x1.25x90mm (x8) M12x1.25x160mm (x14)	JC054  (x4) [31-024274-10] JC055  (x4) [31-025031-10]  JF123 [31-027523-00]	JP069	JH5002	HR602  24-30670-61/0	NF885  [3] 70x159x16mm, FPM [50-307266-70] NF883  [3] 114x171x13mm, FPM [50-307265-70]	KD929 [72] [73] KD931 [72] [73] Steel KD932 [72] [73] Steel JR580 [11] LC280 [11] LC281 [11] Rubber LC282 [11]	 JH5002  JJ283	
HBS255  [22-17021B] M12x1.25x90mm (x8) M12x1.25x160mm (x14)	JC054  (x4) [31-024274-10] JC055  (x4) [31-025031-10]  JF123 [31-027523-00]	JP069	JH5002	HR602  24-30670-61/0	NF885  [3] 70x159x16mm, FPM [50-307266-70] NF883  [3] 114x171x13mm, FPM [50-307265-70]	KD929 [72] [73] KD931 [72] [73] Steel KD932 [72] [73] Steel JR580 [11] LC280 [11] LC281 [11] Rubber LC282 [11]	 JH5002  JJ283	



KW/PS



Jumper 2.8L TD Diesel				07/99 →		143				
8140.43C	2798	4	94.40	Sofim, Common Rail, Turbo		78/106	BX390 (Fibre), 1.20mm [71] (30-027867-00) BX400 (Fibre), 1.30mm [71] (30-027868-00) BX410 (Fibre), 1.40mm [71] (30-027883-00) BX420 (Fibre), 1.50mm [71] (30-027884-00)		GX390▲ (20-27867-00/0)	
Jumpy 1.6L				10/95 →		144	AY460 (Fibre) [249]		DR630	
Jumpy Box 1.6L i				10/95 →			BR630 (Fibre)		(21-26294-21/0)	
1580 SPI/220 A2.000	1581	4	86.40	SPi, SOHC		59/80	(30-027866-00)		ET400 GR630 (20-26294-01/0)	
Jumpy 1.9L D Diesel				10/95 → 04/98		145	BX880 (Fibre), 1.36mm, 1 Notch		DJ720▲	
XUD9A/U (D9B)	1905	4	83.00	SOHC		66/90	(30-028475-00) ☞ 0.56 → 0.67mm BX890 (Fibre), 1.40mm, 2 Notches (30-028476-00) ☞ 0.68 → 0.71mm BX900 (Fibre), 1.44mm, 3 Notches (30-028477-00) ☞ 0.72 → 0.75mm BX910 (Fibre), 1.48mm, 4 Notches (30-028478-00) ☞ 0.76 → 0.79mm BX920 (Fibre), 1.52mm, 5 Notches (30-028479-00) ☞ 0.80 → 0.83mm		(21-25202-22/0) EL890 (22-25198-01/0) GJ720▲ (20-25202-02/0)	
Jumpy 1.9L D 70 Diesel				04/98 →		146	AA5830 (Steel Elastomer), 1.26mm, 1 Hole		CA5830▲	
DW8 (WJZ) / DW8B (WJY)	1868	4	82.20	SOHC		51/70	(30-029190-00) ☞ 0.51 → 0.54mm AA5840 (Steel Elastomer), 1.30mm, 2 Holes (30-029191-00) ☞ 0.55 → 0.58mm AA5850 (Steel Elastomer), 1.34mm, 3 Holes (30-029192-00) ☞ 0.59 → 0.62mm AA5860 (Steel Elastomer), 1.38mm, 4 Holes (30-029193-00) ☞ 0.63 → 0.66mm AA5870 (Steel Elastomer), 1.42mm, 5 Holes (30-029194-00) ☞ 0.67 → 0.70mm AA5880 (Steel Elastomer), 1.46mm, 6 Holes (30-029195-00) ☞ 0.71 → 0.75mm		(21-29482-20/0) EA5830	











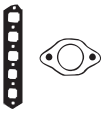

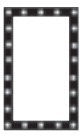

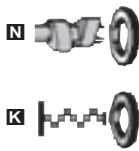

































































								 AA5830, AA5840, AA5850, AA5860, AA5870, AA5880  JJ613
HBS255  (22-17021B) M12x1.25x90mm (x8) M12x1.25x160mm (x14)	JC054  (31-024274-10) JC055  (31-025031-10)  JF123 (31-027523-00)	JN956	JJ613	HR602  24-30670-61/0	 NP067  50x70x10mm, FPM (50-307111-70)  NF885  [3] 70x159x16mm, FPM (50-307266-70)  NF883  [3] 114x171x13mm, FPM (50-307265-70)	JR580 [11]	 AY460, BR630  BX390, BX400, BX410, BX420  BX880, BX890, BX900, BX910, BX920  JC054  JC055  JC423  JC759  JD146  JF123  JF150	
HBS051  (22-17001B) M10x1.25x98mm (x5) M10x1.25x84mm (x5)	JD146 (31-027221-10)  JF150 (31-027151-00)	JP049 (31-026820-00)	JJ453	HR363 		KA293 [13] KA294 [13] KA354 [13] LA378 [53] KT465 [54] KT754 [11] KT756 [11] LR902 [11] KV122 [56]	 BX880, BX890, BX900, BX910, BX920  JC054  JC055  JC423  JC759  JD146  JF123  JF150	
HBS084  (22-15005B) M12x1.50x123mm (x10)	JC759 [60] (31-028417-00) (Steel) JC423  (x2) (31-025199-10)	JN544 (50-025202-00)	JJ283 [6] (31-025198-10)  PA349 (33-102290-10) 22x16x2mm  PB907 14x21x2mm	HR569  24-30667-00/0	 NB959 35x50x7mm, FPM (50-306644-50)  NA5191  42x62x7mm, PTFE (50-319500-00)  NA5192  90x110x7mm, PTFE (50-319501-00)	HL5012 [245]  NA5205 [38]  NF826 [38]  KA611 [13]	 JC423  JC759  JD146  JF123  JF150	
HBS084  (22-15005B) M12x1.50x123mm (x10) →Eng.08469 HBS245  (22-53008B) M12x1.50x125mm (x10) Eng.08470 →	HA5008   JD5192  (x2)	JM5088  JM5089 	 KG5157 10x20x2mm  PB907 14x21x2mm	HR569  24-30667-00/0	 NB959 35x50x7mm, FPM (50-306644-50)  NA5191  42x62x7mm, PTFE (50-319500-00)  NA5192  90x110x7mm, PTFE (50-319501-00)	HL5012 [245]  NA5205 [38]  NA5204 [38] 	 JN544  JN956  JP049  JJ283  JJ453	



KW/PS



Jumpy 1.9L TD Diesel		10/95 →		147				
XUD9TF (D8B)/ XUD9TF/BTF (DHX)	1905	4	83.00	SOHC	66/90	BX930 (Steel Elastomer), 1.36mm, 1 Notch (30-028503-00) BX940 (Steel Elastomer), 1.40mm, 2 Notches (30-028504-00) BX950 (Steel Elastomer), 1.44mm, 3 Notches (30-028505-00) BX960 (Steel Elastomer), 1.48mm, 4 Notches (30-028506-00) BX970 (Steel Elastomer), 1.52mm, 5 Notches (30-028507-00) BX980 (Steel Elastomer), 1.59mm →-0.83mm→	DJ720▲ (21-25202-22/0)	EL890 (22-25198-01/0) GJ720▲ (20-25202-02/0)
Jumpy 2.0L		04/00 →		148				
EW10J4 (RFN)	1997	4	85.00	MPI, DOHC	100/136	AD5300 (MLS)	CD5300	ED5300
Jumpy 2.0L HDI 110 Diesel		03/00 →		149				
DW10ATED (RHZ)	1998	4	85.00	Common Rail	80/109	AC5011 (MLS), 1.30mm, 1 Hole →-0.47→-0.605mm AC5031 (MLS), 1.40mm, 3 Holes (30-029479-10) →-0.655→-0.705mm AC5051 (MLS), 1.50mm, 5 Holes (30-029481-10) →-0.755→-0.83mm	CC5010▲ (21-29484-20/0) Eng.8332→ CC5011▲ Eng.8332→	EA5830
Jumpy 2.0L HDI 110 Diesel		01/02 →		150				
DW10ATED (RHZ)	1998	4	85.00	Common Rail	80/109	AC5011 (MLS), 1.30mm, 1 Hole →-0.47→-0.605mm AC5031 (MLS), 1.40mm, 3 Holes (30-029479-10) →-0.655→-0.705mm AC5051 (MLS), 1.50mm, 5 Holes (30-029481-10) →-0.755→-0.83mm	CC5011▲ CC5010▲ (21-29484-20/0) Eng.8332→	EA5830
Jumpy 2.0L HDI 120 Diesel		01/07 →		151				
Jumpy 2.0L HDI 140 Diesel		01/07 →						
DW10UTED4 (RHK)	1997	4	85.00	Direct Injection, DOHC	79/107	AD5490 (MLS), 1.25mm (30-029789-00) AD5500 (MLS), 1.30mm (30-029790-00) AD5510 (MLS), 1.35mm (30-029791-00) AD5520 (MLS), 1.40mm (30-029792-00)	CD5500▲	ED5500
DW10BTED4 (RHR)	1997	4	85.00	Direct Injection, DOHC				
Jumpy 2.0L HDI 95 Diesel		10/99 →		152				
DW10BTED (RHX)	1997	4	85.00	Direct Injection	69/93	AC5011 (MLS), 1.30mm, 1 Hole →-0.47→-0.605mm AC5031 (MLS), 1.40mm, 3 Holes (30-029479-10) →-0.655→-0.705mm AC5051 (MLS), 1.50mm, 5 Holes (30-029481-10) →-0.755→-0.83mm	CC5010▲ (21-29484-20/0)	EA5830
DW10BTED (RHX)	1997	4	85.00	Direct Injection, SOHC	69/94			
Jumpy 2.0L i 16V		03/00 →		153				
Jumpy Box 2.0L i 16V		03/00 →						
	1997	4			102/138	AD5300 (MLS)	CD5300	ED5300
LNA 0.6L		11/78 →04/85		154				
V06/630/V06/644	652	2	77.00	Carburettor, OHV	25/34			GF053▲ →04/80 GF054▲ 05/80→









								 AD5490, AD5500, AD5510, AD5520
HBS088  (22-15014B) M12x1.50x145mm (x10) →Eng.08574 HBS277  (22-53018B) M12x1.50x148mm (x10) Eng.08575 →	JC759 [60] (31-028417-00) (Steel) JC991 (31-028595-00)	JN544 (50-025202-00)	JJ283 [6] (31-025198-10) ● PA349 (33-102290-10) 22x16x2mm ● PB907 14x21x2mm	HR569  24-30667-00/0	NF841  35x50x8mm, FPM (50-319310-00) →Eng.06265 NB959  35x50x7mm, FPM (50-306644-50) Eng.06265 → NA5191  42x62x7mm, PTFE (50-319500-00) NA5192  90x110x7mm, PTFE (50-319501-00)	HL5010 [245]  HL5012 [245]  NF824 [38]  Evasion, Jumper, Jumpy NF825 [38]  Evasion, Jumper, Jumpy KA611 [13]	 JB830  JB864  JC759  JC991  JN232  JN544  JJ283	
HBS259  (22-53010B) M11x1.50x144.5mm (x10)	JD5833 	JM5283  JM5139 	● PB907 14x21x2mm		NA5256  40x55x6.5mm			
HBS261  (22-53014B) M12x1.50x131mm (x10)	JD5191  JD5190 	JM5087	● KG5157 10x20x2mm ● PB907 14x21x2mm	HR5046 	NA5035  27x47x7mm, FPM (50-319474-00) NA5191  42x62x7mm, PTFE (50-319500-00) NA5192  90x110x7mm, PTFE (50-319501-00)	HL5016 [245]  NA5205 [38]  NA5204 [38] 		
HBS261  (22-53014B) M12x1.50x131mm (x10)	JD5191  JD5190 	JM5087	● KG5157 10x20x2mm ● PB907 14x21x2mm	HR5046 	NA5035  27x47x7mm, FPM (50-319474-00) NA5191  42x62x7mm, PTFE (50-319500-00) NA5192  90x110x7mm, PTFE (50-319501-00)	HL5016 [245]  NA5205 [38]  NA5204 [38] 		
HBS261  (22-53014B) M12x1.50x131mm (x10)	JD5881 	HM5289 	● KG5157 10x20x2mm ● PB907 14x21x2mm	HR5046  (x2)	NA5035  27x47x7mm, FPM (50-319474-00) NA5191  42x62x7mm, PTFE (50-319500-00) NA5192  90x110x7mm, PTFE (50-319501-00)	HL5016 [245]  NA5205 [38]  NA5204 [38] 		
HBS261  (22-53014B) M12x1.50x131mm (x10)	JD5191  JD5190 	JM5087	● KG5157 10x20x2mm ● PB907 14x21x2mm	HR5046 	NA5035  27x47x7mm, FPM (50-319474-00) NA5191  42x62x7mm, PTFE (50-319500-00) NA5192  90x110x7mm, PTFE (50-319501-00)	HL5016 [245]  NA5205 [38]  NA5204 [38] 		
HBS259  (22-53010B) M11x1.50x144.5mm (x10)	JD5833 	JM5283  JM5139 	● PB907 14x21x2mm					
	JB864  (x2) JB830  (x2)	JN232 (x2)	● PA217 16.3x22x2mm		NF812  30x42x8mm, ACM (50-319440-00) NF810  57.5x70x10mm, FPM	NF526 (x2) [2]   NF836 (x2) [38] 		

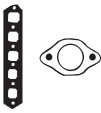

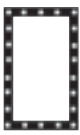
KW/PS

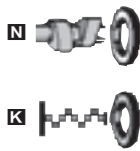

LNA 1.0L		07/84 → 10/86		155		BF290 (Fibre), 1.20mm [33] (30-023670-10) → 11/85 BN570 (Fibre), 1.20mm [35] (30-026351-10) 11/85 →		DN571▲	EH950 [36]
C3A (TU9)	954	4	70.00	Carburettor	33/45				
LNA 1.1L		07/82 → 04/85		156		BH950 (Fibre), 1.20mm, 1 Notch [33] (30-025152-10) BL620 (Fibre), 1.40mm [33] [34] → 12/85 BN580 (Fibre), 1.20mm [35] (30-026021-10) 01/86 →		DN571▲	EH950 [36]
XW7 (109/5E)	1124	4	72.00	Carburettor	33-50/ 45-50				
Mehari Convertible 0.6L		05/68 → 10/87		157				DF050▲■○	GF051 ▲○ [12] (20-22547-03/0)
Mehari Convertible 0.6L 4x4		10/79 → 10/87							
A06/635	602	2	74.00	Carburettor	21/29				
M28/1 (AK2)	602	2	74.00	Carburettor, OHV	21/29				
Nemo 1.4L		02/08 →		158		AD5700 (Fibre), 1.25mm (30-026851-00) AD5710 (Fibre), 1.50mm [34] (30-029799-00)			
	1360	4			54/73				
Relay 1.9L D Diesel		02/94 → 04/02		159		BX880 (Fibre), 1.36mm, 1 Notch (30-028475-00) ☞ 0.56 → 0.67mm BX890 (Fibre), 1.40mm, 2 Notches (30-028476-00) ☞ 0.68 → 0.71mm BX900 (Fibre), 1.44mm, 3 Notches (30-028477-00) ☞ 0.72 → 0.75mm BX910 (Fibre), 1.48mm, 4 Notches (30-028478-00) ☞ 0.76 → 0.79mm BX920 (Fibre), 1.52mm, 5 Notches (30-028479-00) ☞ 0.80 → 0.83mm		DJ720▲ (21-25202-22/0)	EL890 (22-25198-01/0) GJ720 ▲ (20-25202-02/0)
XUD9A/U (D9B)	1905	4	83.00	SOHC	66/90				
Relay 1.9L TD Diesel		02/94 → 04/02		160		BX930 (Steel Elastomer), 1.36mm, 1 Notch (30-028503-00) BX940 (Steel Elastomer), 1.40mm, 2 Notches (30-028504-00) BX950 (Steel Elastomer), 1.44mm, 3 Notches (30-028505-00) BX960 (Steel Elastomer), 1.48mm, 4 Notches (30-028506-00) BX970 (Steel Elastomer), 1.52mm, 5 Notches (30-028507-00) BX980 (Steel Elastomer), 1.59mm ☞ 0.83mm →		DJ720▲ (21-25202-22/0)	EL890 (22-25198-01/0) GJ720 ▲ (20-25202-02/0)
Relay 1.9L TD 4x4 Diesel		08/96 → 04/02							
XUD9TF/BTF (DHX)	1905	4	83.00	SOHC	66/90				
XUD9TE (D8C/DHX)	1905	4	83.00		68/92				
Relay 2.0L		02/94 → 04/02		161		BV140 (Fibre), 1.25mm (30-028760-00) BY320 (Fibre), 1.45mm [34]		CY081▲	ES820 (22-25198-03/0)
Relay 2.0L 4x4		08/96 → 04/02							
Relay Van 2.0L		03/94 → 04/02							
XU10J2 (RFW)	1998	4	86.00	MPi	80/109				
XU10J2	1998	4	86.00	MPi	89/121				











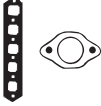

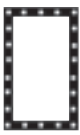

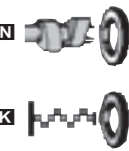







































































								 AD5700, AD5710	 JJ283
			JN596 (50-023671-00)	PA349 (33-102290-10) 22x16x2mm	HR300	NF678 35x50x8mm, ACM NF641 78x100x10mm, MVQ	HR571 [37] NF526 (x2) [2] NF836 (x2) [38] HG108 [39] [40] HL442 [39] [41] LT832 [46]	BF290, BN570 BH950, BL620	
	JC135	JN596 (50-023671-00)	PA349 (33-102290-10) 22x16x2mm	HR300	NF678 35x50x8mm, ACM NF641 78x100x10mm, MVQ	HR564 [37] NF526 (x2) [2] NF836 (x2) [38] HG108 [39] [40] HL442 [39] [41] HG087 [43] [44] LV847 [45] LT832 [46]	BN580 BV140, BY320 BX880, BX890, BX900, BX910, BX920		
	JB864 (x2) JB830 (x2)	JN232 (x2)	PA217 16.3x22x2mm		NF812 30x42x8mm, ACM (50-319440-00) NF809 56x69x10mm, FPM/ACM	NF036 (x6) [2] NF505 (x2) [38] NF577 (x8) [141]	BX930, BX940, BX950, BX960, BX970, BX980		
	JE5072 (MLS)							JB830 JB864	
HBS084 (22-15005B) M12x1.50x123mm (x10)	JC759 [60] (31-028417-00) (Steel) JC423 (x2) (31-025199-10)	JN544 (50-025202-00)	JJ283 [6] (31-025198-10) PA349 (33-102290-10) 22x16x2mm	HR569 24-30667-00/0	NB959 35x50x7mm, FPM (50-306644-50) NA5191 42x62x7mm, PTFE (50-319500-00) NA5192 90x110x7mm, PTFE (50-319501-00)	HL5012 [245] NF824 [38] NF825 [38] KA611 [13]	JC135 JC415 JC423 JC759		
HBS088 (22-15014B) M12x1.50x145mm (x10) →Eng.08574 HBS277 (22-53018B) M12x1.50x148mm (x10) Eng.08575→	JC991 (31-028595-00)	JN544 (50-025202-00)	JJ283 [6] (31-025198-10) PA349 (33-102290-10) 22x16x2mm PB907 14x21x2mm	HR569 24-30667-00/0	NF841 35x50x8mm, FPM (50-319310-00) →Eng.06265 NB959 35x50x7mm, FPM (50-306644-50) Eng.06265→ NA5191 42x62x7mm, PTFE (50-319500-00) NA5192 90x110x7mm, PTFE (50-319501-00)	HL5010 [245] HL5012 [245] NF824 [38] NF825 [38] NF825 [38] KA611 [13]	JC991 JD519 JN232		
HBS245 (22-53008B) M12x1.50x125mm (x10)	JD519 (x2) JC415 (x4) (31-025205-20)	JN547 (50-025204-10)	JJ283 [6] (31-025198-10) PA349 (33-102290-10) 22x16x2mm PB907 14x21x2mm	HR569 24-30667-00/0	NF817 36x50x7mm, FPM (50-319112-00) NA5191 42x62x7mm, PTFE (50-319500-00) NA5192 90x110x7mm, PTFE (50-319501-00)	HL5019 [245] NF824 [38] NF825 [38] KA611 [13]	JN544 JN547 JN596		



KW/PS



Relay 2.0L HDI Diesel				04/02 →	162	AC5011 (MLS), 1.30mm, 1 Hole [30-047→0.605mm AC5031 (MLS), 1.40mm, 3 Holes [30-029479-10] [30-0655→0.705mm AC5051 (MLS), 1.50mm, 5 Holes [30-029481-10] [30-0755→0.83mm	CC5010▲ (21-29484-20/0)	EA5830
DW10UTD (RHV)	1997	4	85.00	Direct Injection	62/84			
Relay 2.2L HDI Diesel				04/02 →	163	AH5080 (MLS), 1.25mm, 1 Hole AH5090 (MLS), 1.30mm, 2 Holes AH5100 (MLS), 1.35mm, 3 Holes AH5110 (MLS), 1.40mm, 4 Holes		
DW12TED (4HY)	2179	4	85.00	Common Rail	74/100			
Relay 2.5L D Diesel				03/94 →04/02	164	BY140 (Fibre) [30-029752-00)	DY140▲ (21-29752-20/0)	EY140 (22-29752-00/0)
Relay 2.5L D 4x4 Diesel				08/96 →04/02				
DJ5 (T9A)	2446	4	92.00	SOHC	63/86			
Relay 2.5L TD Diesel				03/94 →04/02	165	BY140 (Fibre) [30-029752-00)	DY140▲ (21-29752-20/0)	EY140 (22-29752-00/0)
Relay 2.5L TD 4x4 Diesel				08/96 →04/02				
DJ5T (T8A)	2446	4	92.00	SOHC	76/103			
Relay 2.5L TDi Diesel				12/96 →04/02	166	AE5050 (MLS) [30-029793-00)	CE5050▲ (21-29793-20/0)	
Relay 2.5L TDi 4x4 Diesel				12/96 →04/02				
DJ5TED (THX)	2446	4	92.00	SOHC	79/107			
Relay 2.8L HDI Diesel				09/00 →04/02	167	BX390 (Fibre), 1.20mm [71] [30-027867-00) BX400 (Fibre), 1.30mm [71] [30-027868-00) BX410 (Fibre), 1.40mm [71] [30-027883-00) BX420 (Fibre), 1.50mm [71] [30-027884-00)	DX392▲ (21-27867-22/0)	GX392▲ (20-27867-02/0)
Relay 2.8L HDI 4x4 Diesel				09/00 →04/02				
8140.43S	2798	4	94.40	Common Rail	92/125			
Relay 2.8L HDI Diesel				05/04 →	168	BX390 (Fibre), 1.20mm [71] [30-027867-00) BX400 (Fibre), 1.30mm [71] [30-027868-00) BX410 (Fibre), 1.40mm [71] [30-027883-00) BX420 (Fibre), 1.50mm [71] [30-027884-00)	DX400▲ (21-27867-23/0)	GX390▲ (20-27867-00/0)
8140.43N	2798	4	94.40	Direct Injection	107/146			
Saxo 1.0L X				05/96 →	169	BS810 (Fibre), 1.30mm [30-026850-00) BR490 (Fibre), 1.50mm [34] [30-029800-00)	DT012▲ (21-26853-20/0)	EH951 [8] (22-25605-00/0) EH952 (22-25605-02/0)
TU9M (CDY/CDZ)	954	4	70.00	SPi, SOHC	40/54			







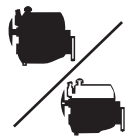



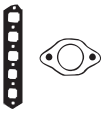

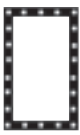

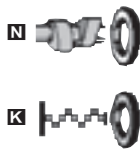











								
HBS261  (22-53014B) M12x1.50x131mm (x10)	JD5191  JD5190 	JM5087	KG5157 10x20x2mm PB907 14x21x2mm	HR5046 	NA5035 27x47x7mm, FPM (50-319474-00) NA5191  42x62x7mm, PTFE (50-319500-00) NA5192  90x110x7mm, PTFE (50-319501-00)	HL5016 [245]  NA5205 [38]  NA5204 [38] 	 AE5050  BS810, BR490  BX390, BX400, BX410, BX420  BY140	
HBS261  (22-53014B) M12x1.50x131mm (x10)			PB907 14x21x2mm	HR5046 	NA5035 27x47x7mm, FPM (50-319474-00)		 JC054  JC055	
HBS114  (22-15017B) M12x1.50x138mm (x14) M10x1.50x148mm (x8)	JD532  JD531  (31-029755-00)		JJ588 (31-029758-00) PB852 16x24x1.5mm PA349 (33-102290-10) 22x16x2mm	HR788 	NB959  35x50x7mm, FPM (50-306644-50) NF866  64x88x6mm, FPM/ACM NF867  98x120x7mm, FPM/ACM	HL5027 [245]  NF824 [38] [146]  NF881 [38] [69]  NF825 [38] [146]  NF882 [38] [69]  KA835 [13]	 JC702  JD532	
HBS114  (22-15017B) M12x1.50x138mm (x14) M10x1.50x148mm (x8)	JD532  JD531  (31-029755-00)		JJ588 (31-029758-00) PB852 16x24x1.5mm PA349 (33-102290-10) 22x16x2mm	HR788 	NB959  35x50x7mm, FPM (50-306644-50) NF866  64x88x6mm, FPM/ACM NF867  98x120x7mm, FPM/ACM	HL5027 [245]  NF881 [38] [69]  NF882 [38] [69] 	 JD551  JF123	
HBS273  (22-53017B) M12x1.50x163mm (x14) M10x1.50x174mm (x8)			PA349 (33-102290-10) 22x16x2mm	HR642 	NB959  35x50x7mm, FPM (50-306644-50) NF866  64x88x6mm, FPM/ACM NF867  98x120x7mm, FPM/ACM	HL5027 [245]  NF881 [38] [69]  NF882 [38] [69]  KA835 [13]	 JN658  JP069	
HBS255  (22-17021B) M12x1.25x90mm (x8) M12x1.25x160mm (x14)	JC054  (x4) (31-024274-10) JC055  (x4) (31-025031-10)  JF123 (31-027523-00)	JP069	JH5002	HR602  24-30670-61/0	NF885  [3] 70x159x16mm, FPM (50-307266-70) NF883  [3] 114x171x13mm, FPM (50-307265-70)	KD929 [72] [73] KD931 [72] [73] Steel KD932 [72] [73] Steel JR580 [11] LC280 [11] LC281 [11] Rubber LC282 [11]	 JN658  JP069  JH5002	
HBS255  (22-17021B) M12x1.25x90mm (x8) M12x1.25x160mm (x14)	JC054  (x4) (31-024274-10) JC055  (x4) (31-025031-10)  JF123 (31-027523-00)	JP069	JH5002	HR602  24-30670-61/0	NF885  [3] 70x159x16mm, FPM (50-307266-70) NF883  [3] 114x171x13mm, FPM (50-307265-70)	KD929 [72] [73] KD931 [72] [73] Steel KD932 [72] [73] Steel JR580 [11] LC280 [11] LC281 [11] Rubber LC282 [11]	 JJ586	
HBS039  (22-15010B) M10x1.50x175mm (x10)	JD551  (x2) (31-029803-00) JC702  (x2) (31-029804-00)	JN658 (50-026853-00)	JJ586 (31-029806-00) PB852 16x24x1.5mm PA349 (33-102290-10) 22x16x2mm	HR642 	NF817 36x50x7mm, FPM (50-319112-00) NF870  42x66x6mm, FPM/ACM (50-319113-00) NF857  85x105x9mm, FPM/ACM (50-319478-00)	HL5011 [245]  HR564 [37]  NA5205 [38]  NA5204 [38]  PA850 [13] PA858 [13]		



KW/PS



Saxo 1.1L X,SX				05/96 →	170			AC5700 (Fibre), 1.26mm (30-029572-00)	CC5700 (21-29572-20/0)	EH951 [8] (22-25605-00/0)
TU1M (H1A)	1124	4	72.00	Carburettor	40/54			TU1JP	TU1JP	TU1M+
TU1JP (HFX)	1124	4	72.00	MPi, SOHC	44/60		BR490 (Fibre), 1.50mm [34] (30-029800-00)	DT010 (21-26851-20/0)	EH952 (22-25605-02/0)	TU1M+
								TU1M+		
Saxo 1.1L X,SX				05/96 →	171			BS810 (Fibre), 1.30mm (30-026850-00)	DT012▲ (21-26853-20/0)	EH951 [8] (22-25605-00/0)
TU1M (H1A)	1124	4	72.00	Carburettor	40/54		BR490 (Fibre), 1.50mm [34] (30-029800-00)			EH952 (22-25605-02/0)
Saxo 1.4L VTS				05/96 →	172			AD5700 (Fibre), 1.25mm (30-026851-00)	DT012▲ (21-26853-20/0)	EH951 [8] (22-25605-00/0)
TU3JP (KFW)/TU3JP (KFX)	1360	4	75.00	MPi, SOHC	55/75		BY130 (Fibre), 1.28mm (30-029099-00)			
							AD5710 (Fibre), 1.50mm [34] (30-029799-00)			
Saxo 1.5L D Diesel				09/96 →	173			BY150 (Fibre), 1.75mm (30-028755-00)	DY150▲ (21-28757-20/0)	
TUD5 (VJY)/TUD5 (VJZ)	1527	4	77.00		42/57					
Saxo 1.6L VTL,VTR				05/96 →	174			BY180 (Fibre), 1.37mm (30-028756-00)	DY130▲ (21-26853-21/0)	EY130 (22-28758-00/0)
Saxo 1.6L VTR				05/96 →07/99						
Saxo 1.6L VTS				09/00 →				AY120 (Fibre), 1.57mm [34] (30-029801-00)		
TU5JP (NFT/NFZ)	1587	4			80/109					
TU5JP (NFT)	1587	4	78.50	MPi	66/89					
	1587	4	78.50	Injection	72/98					
Saxo 1.6L VTS				06/96 →	175			AE5010 (MLS), 1.37mm (30-029786-00)	CE5010 (21-29786-20/0)	
TU5J4 (NFX)	1587	4	78.50	MPi	87/118		AE5020 (MLS), 1.57mm (30-029787-00)			
							AE5030 (MLS), 1.77mm			
Synergy 1.8L				05/97 →07/02	176			BL650 (Fibre), 1.20mm (30-026859-10)	CY131▲ (21-25204-24/0)	EL650 (22-25198-00/0)
XU7JP (LFW/LFZ/L6A)	1761	4	83.00	MPi	73/99		BR510 (Fibre), 1.44mm [34] (30-026858-10)	Evasion Only		











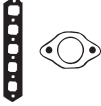

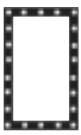

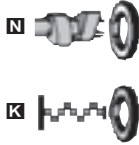

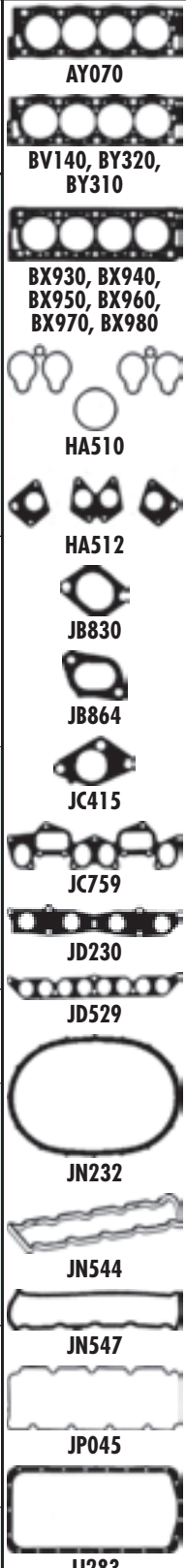



































































								
HBS039 [22-15010B] M10x1.50x175mm (x10)	JD551 [x2] (31-029803-00) TU1M+ JD5828 [x2] HA5028 [x2] JC702 [x2] (31-029804-00) TU1M+ JE189 (31-029805-00) TU1M+	JN658 (50-026853-00)	JJ586 (31-029806-00) TU1M+ ● PB852 16x24x1.5mm ● PA349 (33-102290-10) 22x16x2mm	HR642 [x2]	NF817 36x50x7mm, FPM (50-319112-00) NF870 42x66x6mm, FPM/ACM (50-319113-00) NF857 85x105x9mm, FPM/ACM (50-319478-00)	HL5011 [245] [x2] HR564 [37] [x2] NA5205 [38] [x2] TU1M+ NA5204 [38] [x2] TU1M+ PA850 [13] PA858 [13]		 AC5700  JN658  AD5700, AD5710  JP041  AE5010, AE5020, AE5030  JJ283  AY120  JJ586  BL650  JJ587  BR490, BS810  BY130  BY150  BY180  JC415  JC702  JD519  JD538  JD551  JE189  JN547
HBS039 [22-15010B] M10x1.50x175mm (x10)	JD551 [x2] (31-029803-00) JC702 [x2] (31-029804-00) JE189 (31-029805-00)	JN658 (50-026853-00)	JJ586 (31-029806-00) ● PB852 16x24x1.5mm ● PA349 (33-102290-10) 22x16x2mm	HR642 [x2]	NF817 36x50x7mm, FPM (50-319112-00) NF870 42x66x6mm, FPM/ACM (50-319113-00) NF857 85x105x9mm, FPM/ACM (50-319478-00)	HL5011 [245] [x2] HR564 [37] [x2] NA5205 [38] [x2] NA5204 [38] [x2] PA850 [13] PA858 [13]		
HBS039 [22-15010B] M10x1.50x175mm (x10)	JD538 [x4] (31-029472-00) JD5828 [x2] HA5028 [x2] JC702 [x2] (31-029804-00) JE5072 (MLS)	JN658 (50-026853-00)	● PB852 16x24x1.5mm	HR642 [x2]	NF817 36x50x7mm, FPM (50-319112-00) NF870 42x66x6mm, FPM/ACM (50-319113-00) NF857 85x105x9mm, FPM/ACM (50-319478-00)	HL5011 [245] [x2] HR564 [37] [x2] NA5205 [38] [x2] NA5204 [38] [x2] PA850 [13]		
HBS113 [22-15015B] M11x1.50x185mm (x10)		JP041 (50-028757-00)	JJ587 ● PB907 14x21x2mm	HR642 [x2]	NF817 36x50x7mm, FPM (50-319112-00) NF870 42x66x6mm, FPM/ACM (50-319113-00) NF857 85x105x9mm, FPM/ACM (50-319478-00)	HL5011 [245] [x2] NA5205 [38] [x2] NA5204 [38] [x2] PB259 [14]		
HBS039 [22-15010B] M10x1.50x175mm (x10)	JD530 [x4] JC702 [x2] (31-029804-00) JE189 (31-029805-00)	JN658 (50-026853-00)	JJ587 ● PB852 16x24x1.5mm ● PA349 (33-102290-10) 22x16x2mm	HR642 [x2]	NF817 36x50x7mm, FPM (50-319112-00) NF870 42x66x6mm, FPM/ACM (50-319113-00) NF857 85x105x9mm, FPM/ACM (50-319478-00)	HL5011 [245] [x2] NA5205 [38] [x2] NA5204 [38] [x2]		
HBS254 [22-53009B] M10x1.50x122mm (x10)	JE5044 (31-030016-00) (MLS)	HR397 [57] 34-000410-00			NF870 42x66x6mm, FPM/ACM (50-319113-00) NF857 85x105x9mm, FPM/ACM (50-319478-00)	HL5038 [245] [x2] NA5205 [38] [x2] NA5204 [38] [x2]		
HBS260 [22-53011B] M11x1.50x168mm (x10)	JD519 [x2] JC415 [x4] (31-025205-20)	JN547 (50-025204-10)	JJ283 [6] (31-025198-10) ● PB907 14x21x2mm	HR569 [x2] 24-30667-00/0	NF817 36x50x7mm, FPM (50-319112-00) NA5191 42x62x7mm, PTFE (50-319500-00) NA5192 90x110x7mm, PTFE (50-319501-00)	HL5019 [245] [x2] HR566 [37] [x2] NA5205 [38] [x2] NA5204 [38] [x2] KA611 [13]		



KW/PS



Synergy 1.9L TD Diesel		11/94 → 07/02		177				
XUD9TF (D8B)/ XUD9TF/BTF (DHX)	1905	4	83.00	SOHC	66/90	BX930 (Steel Elastomer), 1.36mm, 1 Notch (30-028503-00) BX940 (Steel Elastomer), 1.40mm, 2 Notches (30-028504-00) BX950 (Steel Elastomer), 1.44mm, 3 Notches (30-028505-00) BX960 (Steel Elastomer), 1.48mm, 4 Notches (30-028506-00) BX970 (Steel Elastomer), 1.52mm, 5 Notches (30-028507-00) BX980 (Steel Elastomer), 1.59mm → 0.83mm →	DJ720▲ (21-25202-22/0)	EL890 (22-25198-01/0) GJ720▲ (20-25202-02/0)
Synergy 2.0L		06/94 → 07/02		178				
XU10J2 (RFU)	1998	4	86.00	MPi	89/121	BV140 (Fibre), 1.25mm (30-028760-00) BY320 (Fibre), 1.45mm [34]	CY082▲ (21-25204-23/0)	ES820 (22-25198-03/0)
Synergy 2.0L 16V		05/98 → 04/00		179				
XU10J4R (RFV)	1998	4	86.00	MPi	99/135	AY070 (Fibre) (30-029744-00)		
Synergy 2.0L 16V		05/00 → 07/02		180				
EW10J4 (RFN)	1997	4	85.00	MPi, DOHC	100/136	AD5300 (MLS)	CD5300	ED5300
Synergy 2.0L HDI Diesel		08/99 → 07/02		181				
DW10ATED (RHZ)	1998	4	85.00	Common Rail	80/109	AC5011 (MLS), 1.30mm, 1 Hole → 0.47 → 0.605mm AC5031 (MLS), 1.40mm, 3 Holes (30-029479-10) → 0.655 → 0.705mm AC5051 (MLS), 1.50mm, 5 Holes (30-029481-10) → 0.755 → 0.83mm	CC5010▲ (21-29484-20/0) → Eng.8331 CC5011▲ Eng.8332 →	EA5830
Synergy 2.0L Turbo C.T.		06/94 → 07/02		182				
XU10J2TE (RGX)	1998	4	86.00	SOHC	108/147	BY310 (Fibre), 1.25mm (30-028761-00) BY320 (Fibre), 1.45mm [34]	DY310▲ (21-25204-25/0)	ES820 (22-25198-03/0)
Synergy 2.1L TD Diesel		05/96 → 07/02		183				
XUD11BTE (P8C)	2088	4	85.00		81/110	BY941 (MLS), 1.52mm (30-027543-20) → 0.65 → 0.76mm BY961 (MLS), 1.62mm (30-028712-10) → 0.82 → 0.86mm BY981 (MLS), 1.72mm (30-028714-10) → 0.92 → 0.96mm	DV150▲ (21-27540-20/0)	EV150 (22-25198-02/0)
Visa 0.6L		07/82 → 03/91		184				
V06/665	647	2	77.00	Carburettor, OHV	24/33			GF054▲
Visa 0.6L		09/78 → 06/88		185				
V06/630/V06/644	652	2	77.00	Carburettor, OHV	25/34			GF053▲ → 04/80 GF054▲ 05/80 →











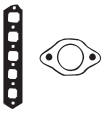

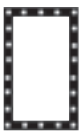





								
HBS088  (22-15014B) M12x1.50x145mm (x10) →Eng.08574 HBS277  (22-53018B) M12x1.50x148mm (x10) Eng.08575 →	JC759 [60] (31-028417-00) (Steel)	JN544 (50-025202-00)	JJ283 [6] (31-025198-10) PA349 (33-102290-10) 22x16x2mm PB907 14x21x2mm	HR569  24-30667-00/0	NF841  35x50x8mm, FPM (50-319310-00) →Eng.06264 NB959  35x50x7mm, FPM (50-306644-50) Eng.06265 → NA5191  42x62x7mm, PTFE (50-319500-00) NA5192  90x110x7mm, PTFE (50-319501-00)	HL5010 [245]  HL5012 [245]  NF824 [38]  NF825 [38]  KA611 [13]	AY070 BV140, BY320, BY310 BX930, BX940, BX950, BX960, BX970, BX980 HA510 HA512 JB830 JB864 JC415 JC759 JD230 JD529 JN232 JN544 JN547 JP045 JJ283	
HBS084  (22-15005B) M12x1.50x123mm (x10)	HA510  JC415  (x4) (31-025205-20)	JN547 (50-025204-10)	JJ283 [6] (31-025198-10) PA349 (33-102290-10) 22x16x2mm PB907 14x21x2mm	HR569  24-30667-00/0	NF817  36x50x7mm, FPM (50-319112-00) NA5191  42x62x7mm, PTFE (50-319500-00) NA5192  90x110x7mm, PTFE (50-319501-00)	HL5019 [245]  NA5205 [38]  NA5204 [38]  KA611 [13]		
HBS087  (22-15013B) M12x1.50x110mm (x10) →Eng.08581 HBS278  (22-53019B) M12x1.50x110mm (x10) Eng.08582 →			PB907 14x21x2mm	HR5080  (24-30710-45/0) →Eng.07359 HR5081  (24-30721-87/0) Eng.07360 → →Eng.07965	NF817  36x50x7mm, FPM (50-319112-00) NA5191  42x62x7mm, PTFE (50-319500-00) NA5192  90x110x7mm, PTFE (50-319501-00)	HL5019 [245]  NA5205 [38]  NA5204 [38]  KA611 [13]		
HBS259  (22-53010B) M11x1.50x144.5mm (x10)	JD5833 	JM5283  JM5139 	PB907 14x21x2mm		NA5256  40x55x6.5mm			
HBS261  (22-53014B) M12x1.50x131mm (x10)	JD5191  JD5190 	JM5087	KG5157 10x20x2mm PB907 14x21x2mm	HR5046 	NA5035  27x47x7mm, FPM (50-319474-00) NA5191  42x62x7mm, PTFE (50-319500-00) NA5192  90x110x7mm, PTFE (50-319501-00)	HL5016 [245]  NA5205 [38]  NA5204 [38] 		
HBS084  (22-15005B) M12x1.50x123mm (x10)	HA512 	JN547 (50-025204-10)	JJ283 [6] (31-025198-10) PB907 14x21x2mm	HR569  24-30667-00/0	NF817  36x50x7mm, FPM (50-319112-00) NA5191  42x62x7mm, PTFE (50-319500-00) NA5192  90x110x7mm, PTFE (50-319501-00)	HL5019 [245]  NF824 [38]  NF825 [38]  KA611 [13]		
HBS125  (22-15007B) M12x1.50x150.5mm (x10)	JD529  (31-027540-00) JD230 	JP045 (50-028922-00)	PB907 14x21x2mm	HR805 	NF841  35x50x8mm, FPM (50-319310-00) NA5191  42x62x7mm, PTFE (50-319500-00) NA5192  90x110x7mm, PTFE (50-319501-00)	HL5010 [245]  NF824 [38]  NF825 [38]  KA611 [13]		
	JB864  (x2) JB830  (x2)	JN232 (x2)	PA217 16.3x22x2mm		NF812  30x42x8mm, ACM (50-319440-00) NF810  57.5x70x10mm, FPM	NF526 (x2) [2]  		
	JB864  (x2) JB830  (x2)	JN232 (x2)	PA217 16.3x22x2mm		NF812  30x42x8mm, ACM (50-319440-00) NF810  57.5x70x10mm, FPM	NF526 (x2) [2]   NF334 (x2) [38]		



KW/PS



Visa 1.0L		09/84 → 06/88		186		BN570 (Fibre), 1.20mm [35] (30-026351-10)		DN571▲	EH950 [36]
TU9 (C1A)	954	4	70.00	Carburettor, SOHC	33/45				
XV8 (108C)	954	4	70.00	Carburettor	33/45				
TU9M (CDY/CDZ)	954	4	70.00	SPi, SOHC	40/54				
Visa 11 E		09/78 → 03/91		187		BH950 (Fibre), 1.20mm, 1 Notch [33] (30-025152-10) →12/85		DN571▲	EH950 [36]
Visa Convertible 11 RE		03/83 → 10/88				BL620 (Fibre), 1.40mm [33][34] →12/85			
XW7 (109/5F)	1124	4	72.00	Carburettor	33-37/ 45-50				
XW7 (109K)	1124	4	72.00	Carburettor	35/47				
XW7 (109/5)	1124	4	72.00	Carburettor	37/50	BN580 (Fibre), 1.20mm [35] (30-026021-10) 01/86→			
Visa 14		07/84 → 03/91		188		BN580 (Fibre), 1.20mm [35] (30-026021-10)		DN582▲	EH950 [36]
Visa 14 GT		03/82 → 03/91				BH950 (Fibre), 1.20mm, 1 Notch [33] (30-025152-10)			
XY7 (150D)	1360	4	75.00	Carburettor, SOHC	44/60				
XY8 (150B)	1360	4	75.00	Carburettor	46/62	BL620 (Fibre), 1.40mm [33][34]			
Visa 14 GT		03/82 → 03/87		189		BN580 (Fibre), 1.20mm [35] (30-026021-10)		DN582▲	EH950 [36]
TU3FJ2 (K2D)	1360	4	75.00	Carburettor	55/75				
TU3FM (KDY)	1360	4	75.00	SPi, SOHC	55/75	BH950 (Fibre), 1.20mm, 1 Notch [33] (30-025152-10)			
TU3JP (KFW)/TU3JP (KFX)	1360	4	75.00	MPi, SOHC	55/75	BL620 (Fibre), 1.40mm [33][34]			
TU3M (KDX)/TU3M (KDY)/TU3M/Z (KDZ)	1360	4	75.00	SPi, SOHC	55/75				
Visa 16 GTI		01/85 → 03/91		190		BL650 (Fibre), 1.20mm (30-026859-10)		DL650 DN590▲	EL650 (22-25198-00/0) GL650
XU5J (180A/B6D)	1580	4	83.00	MPi	76/103	BR510 (Fibre), 1.44mm [34] (30-026858-10)			
XU5JA (B6D)	1580	4	83.00	MPi	83/113				











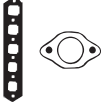

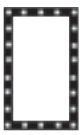

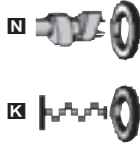

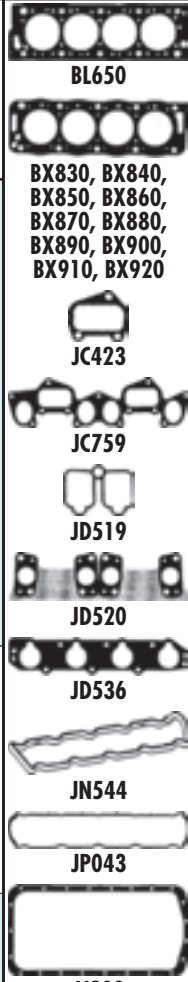





































































								 BH950, BL620  BL650  BN570  BN580  JC135  JC415  JC750  JE647  JN547  JN596
		JN596 (50-023671-00)	PA349 (33-102290-10) 22x16x2mm	HR300	NF678 35x50x8mm, ACM NF641 78x100x10mm, MVQ	HR564 [37] S NF526 (x2) [2] F NF334 (x2) [38] NF836 (x2) [38] K HG108 [39] [40] S HL442 [39] [41] S LV847 [45] LT832 [46]		
	JC135 JE647 [47] (31-022193-10)	JN596 (50-023671-00)	PA349 (33-102290-10) 22x16x2mm	HR300	NF678 35x50x8mm, ACM NF641 78x100x10mm, MVQ	HR564 [37] S HR571 [37] S →12/79 →Eng.44200 NF526 (x2) [2] F NF334 (x2) [38] NF836 (x2) [38] K HG108 [39] [40] S HL442 [39] [41] S HG087 [43] [44] S →12/85 HG104 [43] [48] S →12/85 LV847 [45] LT832 [46]		
	JC135	JN596 (50-023671-00)	PA349 (33-102290-10) 22x16x2mm	HR300	NF678 35x50x8mm, ACM NF641 78x100x10mm, MVQ	HR564 [37] S NF526 (x2) [2] F NF836 (x2) [38] K HG108 [39] [40] S HL442 [39] [41] S HG093 [43] [48] S LV847 [45] LT832 [46]		
	JC135 JE5072 (MLS)	JN596 (50-023671-00)	PA349 (33-102290-10) 22x16x2mm	HR300	NF678 35x50x8mm, ACM NF641 78x100x10mm, MVQ	HR564 [37] S NF526 (x2) [2] F NF836 (x2) [38] K HG108 [39] [40] S HL442 [39] [41] S HG093 [43] [48] S LV847 [45] LT832 [46]		
HBS083  (22-15002B) M11x1.50x168mm (x10) →Eng.03764 HBS038  (22-15003B) M11x1.50x175mm (x10) Eng.03765→	JC750 JC415  (x4) (31-025205-20)	JN547 (50-025204-10)	PA349 (33-102290-10) 22x16x2mm	HR300	NF817 36x50x7mm, FPM (50-319112-00) NA5191 42x62x7mm, PTFE (50-319500-00) NA5192 90x110x7mm, PTFE (50-319501-00)	HL5019 [245] S HR566 [37] S NF836 [38] K NF826 [38] K KA611 [13]		



KW/PS



Cylinder Head				CC	Configuration	Power (KW/PS)	Part Number	Notes	Accessories	
Visa 17 D Diesel					04/84 → 03/91	191	BX830 (Fibre), 1.36mm, 1 Notch (30-028484-00) -0.56 → 0.67mm BX840 (Fibre), 1.40mm, 2 Notches (30-028485-00) -0.68 → 0.71mm BX850 (Fibre), 1.44mm, 3 Notches (30-028486-00) -0.72 → 0.75mm BX860 (Fibre), 1.48mm, 4 Notches (30-028487-00) -0.76 → 0.79mm BX870 (Fibre), 1.52mm, 5 Notches (30-028488-00) -0.80 → 0.83mm		DJ720▲ (21-25202-22/0)	EL890 (22-25198-01/0) GJ720▲ (20-25202-02/0)
Xantia 1.6L i					03/93 → 01/98	192	BL650 (Fibre), 1.20mm (30-026859-10) BR510 (Fibre), 1.44mm [34] (30-026858-10)		CY130▲ (21-28759-20/0) EL650 (22-25198-00/0)	
Xantia 1.8L i					03/93 → 01/98	193	BL650 (Fibre), 1.20mm (30-026859-10) BR510 (Fibre), 1.44mm [34] (30-026858-10)		CY130▲ (21-28759-20/0) EL650 (22-25198-00/0)	
Xantia 1.8L i					04/97 → 04/03	194	BL650 (Fibre), 1.20mm (30-026859-10) BR510 (Fibre), 1.44mm [34] (30-026858-10)		DL651▲ (21-28759-22/0) EL650 (22-25198-00/0)	
Xantia 1.8L i 16V					06/95 → 04/03	195	AD5100 (Fibre)		CD5100 → Eng.7965	
Xantia 1.9L D Diesel					06/94 → 01/98	196	BX880 (Fibre), 1.36mm, 1 Notch (30-028475-00) -0.56 → 0.67mm BX890 (Fibre), 1.40mm, 2 Notches (30-028476-00) -0.68 → 0.71mm BX900 (Fibre), 1.44mm, 3 Notches (30-028477-00) -0.72 → 0.75mm BX910 (Fibre), 1.48mm, 4 Notches (30-028478-00) -0.76 → 0.79mm BX920 (Fibre), 1.52mm, 5 Notches (30-028479-00) -0.80 → 0.83mm		DJ720▲ (21-25202-22/0) EL890 (22-25198-01/0) GJ720▲ (20-25202-02/0)	

								
HBS084  (22-15005B) M12x1.50x123mm (x10) →Eng.08469 HBS245  (22-53008B) M12x1.50x125mm (x10) Eng.08470 →	JC423  (x2) (31-025199-10)	JN544 (50-025202-00)	JJ283 [6] (31-025198-10) PA349 (33-102290-10) 22x16x2mm PB907 14x21x2mm	HR569  24-30667-00/0	NF841 35x50x8mm, FPM (50-319310-00) NA5191  42x62x7mm, PTFE (50-319500-00) NA5192  90x110x7mm, PTFE (50-319501-00)	HL5010 [245]  NF836 [38]  NF826 [38]  KA611 [13]	HL5010 [245]  NF836 [38]  NF826 [38]  KA611 [13]	BL650 BX830, BX840, BX850, BX860, BX870, BX880, BX890, BX900, BX910, BX920 JC423 JC759 JD519 JD520 JD536 JN544 JP043 JJ283
HBS038  (22-15003B) M11x1.50x175mm (x10) →Eng.07448 HBS260  (22-53011B) M11x1.50x168mm (x10) Eng.07449 →	JD519  (x2) JD520  (x4)	JP043 (50-028759-00)	JJ283 [6] (31-025198-10) PA349 (33-102290-10) 22x16x2mm PB907 14x21x2mm	HR569  24-30667-00/0	NF817 36x50x7mm, FPM (50-319112-00) NA5191  42x62x7mm, PTFE (50-319500-00) NA5192  90x110x7mm, PTFE (50-319501-00)	HL5019 [245]  HR566 [37]  NF836 [38]  NF826 [38]  KA611 [13]	HL5019 [245]  HR566 [37]  NF836 [38]  NF826 [38]  KA611 [13]	JD536 JN544 JP043 JJ283
HBS260  (22-53011B) M11x1.50x168mm (x10)	JD519  (x2) JD520  (x4)	JP043 (50-028759-00)	JJ283 [6] (31-025198-10) PB907 14x21x2mm	HR569  24-30667-00/0	NF817 36x50x7mm, FPM (50-319112-00) NA5191  42x62x7mm, PTFE (50-319500-00) NA5192  90x110x7mm, PTFE (50-319501-00)	HL5019 [245]  HR566 [37]  NF836 [38]  NF826 [38]  KA611 [13]	HL5019 [245]  HR566 [37]  NF836 [38]  NF826 [38]  KA611 [13]	
HBS260  (22-53011B) M11x1.50x168mm (x10)	JD520  (x4)	JP043 (50-028759-00)	PB907 14x21x2mm	HR569  24-30667-00/0	NF817 36x50x7mm, FPM (50-319112-00) NA5191  42x62x7mm, PTFE (50-319500-00) NA5192  90x110x7mm, PTFE (50-319501-00)	HL5019 [245]  HR566 [37]  NA5205 [38]  NA5204 [38]  KA611 [13]	HL5019 [245]  HR566 [37]  NA5205 [38]  NA5204 [38]  KA611 [13]	
HBS089  (22-15016B) M11x1.50x159mm (x10)	JD536  JD5832 		PB907 14x21x2mm	HR5080  (24-30710-45/0) →Eng.07359 HR5081  (24-30721-87/0) Eng.07360 → →Eng.07965	NF817 36x50x7mm, FPM (50-319112-00) NA5191  42x62x7mm, PTFE (50-319500-00) NA5192  90x110x7mm, PTFE (50-319501-00)	HL5019 [245]  HR566 [37]  NA5205 [38]  NA5204 [38]  KA611 [13]	HL5019 [245]  HR566 [37]  NA5205 [38]  NA5204 [38]  KA611 [13]	
HBS084  (22-15005B) M12x1.50x123mm (x10)	JC759 [60] (31-028417-00) (Steel)	JN544 (50-025202-00)	JJ283 [6] (31-025198-10) PA349 (33-102290-10) 22x16x2mm PB907 14x21x2mm	HR569  24-30667-00/0	NB959 35x50x7mm, FPM (50-306644-50) NA5191  42x62x7mm, PTFE (50-319500-00) NA5192  90x110x7mm, PTFE (50-319501-00)	HL5012 [245]  NF836 [38]  NF826 [38]  KA611 [13]	HL5012 [245]  NF836 [38]  NF826 [38]  KA611 [13]	



KW/PS

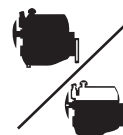

Xantia 1.9L SD Diesel				02/96 → 04/03		197	BX930 (Steel Elastomer), 1.36mm, 1 Notch (30-028503-00) BX940 (Steel Elastomer), 1.40mm, 2 Notches (30-028504-00) BX950 (Steel Elastomer), 1.44mm, 3 Notches (30-028505-00) BX960 (Steel Elastomer), 1.48mm, 4 Notches (30-028506-00) BX970 (Steel Elastomer), 1.52mm, 5 Notches (30-028507-00) BX980 (Steel Elastomer), 1.59mm → -0.83mm →	DJ720 ▲ (21-25202-22/0)	EL890 (22-25198-01/0) GJ720 ▲ (20-25202-02/0)
XUD9SD (DHW)	1905	4	83.00		66/89				
Xantia 1.9L Turbo D Diesel				10/94 → 04/03		198	BX930 (Steel Elastomer), 1.36mm, 1 Notch (30-028503-00) BX940 (Steel Elastomer), 1.40mm, 2 Notches (30-028504-00) BX950 (Steel Elastomer), 1.44mm, 3 Notches (30-028505-00) BX960 (Steel Elastomer), 1.48mm, 4 Notches (30-028506-00) BX970 (Steel Elastomer), 1.52mm, 5 Notches (30-028507-00) BX980 (Steel Elastomer), 1.59mm → -0.83mm →	DJ720 ▲ (21-25202-22/0)	EL890 (22-25198-01/0) GJ720 ▲ (20-25202-02/0)
XUD9TE (DHY/D8A)	1905	4	83.00		44/66/ 60/90				
XUD9TF (D8B)/ XUD9TF/BTF (DHX)	1905	4	83.00	SOHC	66/90				
Xantia 2.0L HDI 109 Diesel				02/99 → 04/03		199	AC5011 (MLS), 1.30mm, 1 Hole → -0.47 → -0.605mm AC5031 (MLS), 1.40mm, 3 Holes (30-029479-10) → -0.655 → -0.705mm AC5051 (MLS), 1.50mm, 5 Holes (30-029481-10) → -0.755 → -0.83mm	CC5010 ▲ (21-29484-20/0) → Eng.8331 CC5011 ▲ Eng.8332 →	EA5830
Xantia 2.0L HDI 90 Diesel				03/99 → 04/03					
DW10TD (RHY)	1998	4	85.00	Common Rail	63/86				
DW10ATED (RHZ)	1998	4	85.00	Common Rail	80/109				
Xantia 2.0L i				03/93 → 04/03		200	BV140 (Fibre), 1.25mm (30-028760-00) BY320 (Fibre), 1.45mm [34]	CY080 ▲ (21-28759-21/0)	ES820 (22-25198-03/0)
XU10J2C (RFX)	1998	4	86.00	MPi	89-90/ 120- 122				
Xantia 2.0L i 16V				03/93 → 01/98		201	AY090 (Fibre), 1.25mm (30-028762-00) AY100 (Fibre), 1.45mm [34]	CY090 ▲	ES820 (22-25198-03/0)
XU10J4 (RFT)/ XU10J4 (RFY)	1998	4	86.00	MPi, DOHC	112/152				
Xantia 2.0L i 16V				06/95 → 04/03		202	AY070 (Fibre) (30-029744-00)		
XU10J4R (RFV)	1998	4	86.00	MPi	99/135				
Xantia 2.0L Turbo				06/95 → 04/03		203	BY310 (Fibre), 1.25mm (30-028761-00) BY320 (Fibre), 1.45mm [34]	DY310 ▲ (21-25204-25/0)	ES820 (22-25198-03/0)
XU10J2TE (RGX)	1998	4	86.00	SOHC	108/147				

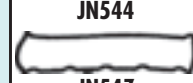
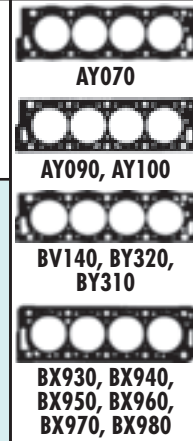
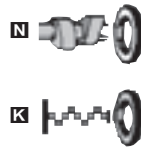
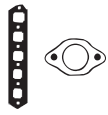











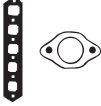

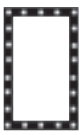





















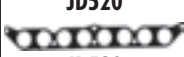





















































HBS084 [E] [22-15005B] M12x1.50x123mm (x10)	JC759 [60] (31-028417-00) (Steel) JC991 (31-028595-00)	JN544 (50-025202-00)	JJ283 [6] (31-025198-10) ● PA349 (33-102290-10) 22x16x2mm ● PB907 14x21x2mm	HR569 [S] 24-30667-00/0	NF841 35x50x8mm, FPM (50-319310-00) NB959 35x50x7mm, FPM (50-306644-50) NA5191 42x62x7mm, PTFE (50-319500-00) NA5192 90x110x7mm, PTFE (50-319501-00)	HL5010 [245] [S] HL5012 [245] [S] NA5205 [38] [K] NA5204 [38] [K] KA611 [13]
HBS088 [E] [22-15014B] M12x1.50x145mm (x10) →Eng.08574 HBS277 [E] [22-53018B] M12x1.50x148mm (x10) Eng.08575 →	JC991 (31-028595-00)	JN544 (50-025202-00)	JJ283 [6] (31-025198-10) ● PA349 (33-102290-10) 22x16x2mm ● PB907 14x21x2mm	HR569 [S] 24-30667-00/0	NB959 35x50x7mm, FPM (50-306644-50) NA5191 42x62x7mm, PTFE (50-319500-00) NA5192 90x110x7mm, PTFE (50-319501-00)	HL5012 [245] [S] NA5205 [38] [K] NA5204 [38] [K] KA611 [13]
HBS261 [E] [22-53014B] M12x1.50x131mm (x10)	JD5191 [I] JD5190 [E]	JM5087	● KG5157 10x20x2mm ● PB907 14x21x2mm	HR5046 [S]	NA5035 27x47x7mm, FPM (50-319474-00) NA5191 42x62x7mm, PTFE (50-319500-00) NA5192 90x110x7mm, PTFE (50-319501-00)	HL5016 [245] [S] NA5205 [38] [K] NA5204 [38] [K]
HBS084 [E] [22-15005B] M12x1.50x123mm (x10)	HA510 [I] [S] JD520 [E] (x4)	JP043 (50-028739-00)	JJ283 [6] (31-025198-10) ● PA349 (33-102290-10) 22x16x2mm ● PB907 14x21x2mm	HR569 [S] 24-30667-00/0	NF817 36x50x7mm, FPM (50-319112-00) NA5191 42x62x7mm, PTFE (50-319500-00) NA5192 90x110x7mm, PTFE (50-319501-00)	HL5019 [245] [S] NA5205 [38] [K] NA5204 [38] [K] KA611 [13]
HBS087 [E] [22-15013B] M12x1.50x110mm (x10) →Eng.08581 HBS278 [E] [22-53019B] M12x1.50x110mm (x10) Eng.08582 →	JD536 [I]	JP044 (50-028763-00)	JJ283 [6] (31-025198-10) ● PA349 (33-102290-10) 22x16x2mm ● PB907 14x21x2mm	HR642 [S]	NF817 (x2) 36x50x7mm, FPM (50-319112-00) NA5191 42x62x7mm, PTFE (50-319500-00) NA5192 90x110x7mm, PTFE (50-319501-00)	HL5019 [245] [S] NF836 [38] [K] NF826 [38] [K] KA611 [13]
HBS087 [E] [22-15013B] M12x1.50x110mm (x10) →Eng.08581 HBS278 [E] [22-53019B] M12x1.50x110mm (x10) Eng.08582 →	JD536 [I]		● PB907 14x21x2mm	HR5080 [S] (24-30710-45/0) →Eng.07359 HR5081 [S] (24-30721-87/0) Eng.07360 → →Eng.07965	NF817 36x50x7mm, FPM (50-319112-00) Xantia, XM NA5191 42x62x7mm, PTFE (50-319500-00) NA5192 90x110x7mm, PTFE (50-319501-00)	HL5019 [245] [S] NA5205 [38] [K] NA5204 [38] [K] KA611 [13]
HBS084 [E] [22-15005B] M12x1.50x123mm (x10)	HA512 [E] [S]	JN547 (50-025204-10)	JJ283 [6] (31-025198-10) ● PB907 14x21x2mm	HR569 [S] 24-30667-00/0	NF817 36x50x7mm, FPM (50-319112-00) NA5191 42x62x7mm, PTFE (50-319500-00) NA5192 90x110x7mm, PTFE (50-319501-00)	HL5019 [245] [S] NF824 [38] [K] NF825 [38] [K] KA611 [13]



KW/PS



Xantia 2.1L Turbo D 12V Diesel				06/95 → 02/99	204	BY941 (MLS), 1.52mm (30-027543-20) ⊖0.65 → 0.76mm BY961 (MLS), 1.62mm (30-028712-10) ⊖0.82 → 0.86mm BY981 (MLS), 1.72mm (30-028714-10) ⊖0.92 → 0.96mm	DV150▲ (21-27540-20/0)	EV150 (22-25198-02/0)
Xantia 3.0L i 24V				01/97 → 01/98	205	AG9710 (MLS), 1.40mm ◀	CG9720◀ CG9740▶	EG9710
Xantia 3.0L V6				01/98 → 04/03		AG9720 (MLS), 1.65mm ◀ AG9730 (MLS), 1.40mm ▶ AG9740 (MLS), 1.65mm ▶		
ES9J4 (XFZ)				2946	6	87.00	MPi, V6	152/207
XM 2.0L				05/89 → 04/94	206	BS820 (Fibre), 1.25mm (30-027556-00)	DS820▲ (21-25204-22/0)	ES820 (22-25198-03/0)
XM 2.0L i				05/89 → 04/94		BV140 (Fibre), 1.25mm (30-028760-00)		
XU10MZ (RDZ)				1998	4	86.00	SPi, SOHC	84/114 81/110
XM 2.0L i				05/89 → 06/94	207	BV140 (Fibre), 1.25mm (30-028760-00) BY320 (Fibre), 1.45mm [34]	CY080▲ (21-28759-21/0)	ES820 (22-25198-03/0)
XU10J2 (RFZ)				1998	4	86.00	MPi	89-90/ 121- 122
XM 2.0L i				11/91 → 04/94	208	BS820 (Fibre), 1.25mm (30-027556-00) BV140 (Fibre), 1.25mm (30-028760-00) XU10M	DS820▲ (21-25204-22/0)	ES820 (22-25198-03/0)
XU102C (R2A)				1998	4	86.00	Injection, SOHC	79/107
XU10MZ (RDZ)				1998	4	86.00	SPi, SOHC	81/110
XM 2.0L i 16V				05/94 → 10/00	209	AY070 (Fibre) (30-029744-00)		
XU10J4R (RFV)				1998	4	86.00	MPi	99/135
XM 2.0L i Turbo				09/92 → 06/94	210	BY310 (Fibre), 1.25mm (30-028761-00) BY320 (Fibre), 1.45mm [34]	DY310▲ (21-25204-25/0)	ES820 (22-25198-03/0)
XM 2.0L Turbo				09/92 → 10/00				
XU10J2TE (RGX)/ XU10J2TE (RGX/RGY)				1998	4	86.00	SOHC	108/147
XM 2.1L D 12V Diesel				05/89 → 06/94	211	BV150 (Fibre), 1.58mm, 2 Notches ⊖0.65 → 0.77mm BV160 (Fibre), 1.70mm, 3 Notches (30-027546-00) ⊖0.77 → 0.82mm	DV150▲ (21-27540-20/0)	EV150 (22-25198-02/0)
XM 2.1L D12 Diesel				07/94 → 06/96				
XUD11A (P9A/PJZ)				2138	4	86.00		61/82







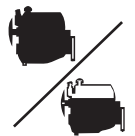



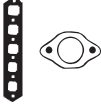

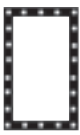

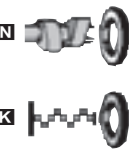

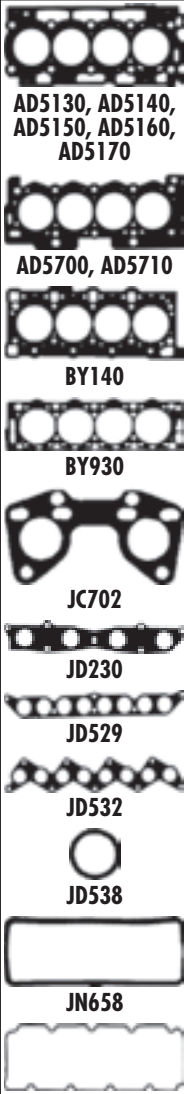















































								
HBS125  (22-15007B) M12x1.50x150.5mm (x10)	JD529  (31-027540-00) JD230 	JP045 (50-028922-00)	PB907 14x21x2mm	HR805 	NF841 35x50x8mm, FPM (50-319310-00) NA5191  42x62x7mm, PTFE (50-319500-00) NA5192  90x110x7mm, PTFE (50-319501-00)	HL5010 [245]  NF824 [38]  NF825 [38] 	 AY070  BS820  BV140, BY320, BY310  BV150  BV160  HA510  HA512  JC415  JD230  JD520  JD529  JD536  JN547  JP043  JP045  JJ283	
HBS272  (22-53016B) M10x1.50x147mm (x16)	JD5879  JD5880  (Steel Elastomer) JD5878  (MLS)		PB852 16x24x1.5mm	HR5062  24-30614-73/0	NA5260 38x50x6mm			
HBS084  (22-15005B) M12x1.50x123mm (x10)	JC415  (x4) (31-025205-20)	JN547 (50-025204-10)	JJ283 [6] (31-025198-10) PA349 (33-102290-10) 22x16x2mm PB907 14x21x2mm	HR569  24-30667-00/0	NF817 36x50x7mm, FPM (50-319112-00) NA5191  42x62x7mm, PTFE (50-319500-00) NA5192  90x110x7mm, PTFE (50-319501-00)	HL5019 [245]  NF836 [38]  NF826 [38]  KA611 [13]		
HBS084  (22-15005B) M12x1.50x123mm (x10)	HA510   JD520  (x4)	JP043 (50-028759-00)	JJ283 [6] (31-025198-10) PA349 (33-102290-10) 22x16x2mm PB907 14x21x2mm	HR569  24-30667-00/0	NF817 36x50x7mm, FPM (50-319112-00) NA5191  42x62x7mm, PTFE (50-319500-00) NA5192  90x110x7mm, PTFE (50-319501-00)	HL5019 [245]  NF836 [38]  NF826 [38]  KA611 [13]		
HBS084  (22-15005B) M12x1.50x123mm (x10)	JC415  (x4) (31-025205-20)	JN547 (50-025204-10)	JJ283 [6] (31-025198-10) PA349 (33-102290-10) 22x16x2mm PB907 14x21x2mm	HR569  24-30667-00/0	NF817 36x50x7mm, FPM (50-319112-00) NA5191  42x62x7mm, PTFE (50-319500-00) NA5192  90x110x7mm, PTFE (50-319501-00)	HL5019 [245]  NF836 [38]  NF826 [38]  KA611 [13]		
HBS087  (22-15013B) M12x1.50x110mm (x10) →Eng.08581 HBS278  (22-53019B) M12x1.50x110mm (x10) Eng.08582 →	JD536 		PB907 14x21x2mm	HR5080  (24-30710-45/0) →Eng.07359 HR5081  (24-30721-87/0) Eng.07360 → →Eng.07965	NF817 36x50x7mm, FPM (50-319112-00) Xantia, XM NA5191  42x62x7mm, PTFE (50-319500-00) NA5192  90x110x7mm, PTFE (50-319501-00)	HL5019 [245]  NA5205 [38]  NA5204 [38]  KA611 [13]		
HBS084  (22-15005B) M12x1.50x123mm (x10)	HA512  	JN547 (50-025204-10)	JJ283 [6] (31-025198-10) PB907 14x21x2mm	HR569  24-30667-00/0	NF817 36x50x7mm, FPM (50-319112-00) NA5191  42x62x7mm, PTFE (50-319500-00) NA5192  90x110x7mm, PTFE (50-319501-00)	HL5019 [245]  NF824 [38]  NF825 [38]  KA611 [13]		
HBS115  (22-15006B) M12x1.50x145mm (x10)	JD529  (31-027540-00) JD230 	JP045 (50-028922-00)	JJ283 [6] (31-025198-10) PA349 (33-102290-10) 22x16x2mm	HR805 	NF841 35x50x8mm, FPM (50-319310-00) NA5191  42x62x7mm, PTFE (50-319500-00) NA5192  90x110x7mm, PTFE (50-319501-00)	HL5010 [245]  NF836 [38]  NF826 [38]  KA611 [13]		



KW/PS



XM 2.1L TD 12V Diesel				05/89 → 06/94		212	BY930 (MLS), 1.35mm -0.54 → 0.64mm BY941 (MLS), 1.52mm (30-027543-20) -0.65 → 0.76mm BY961 (MLS), 1.62mm (30-028712-10) -0.82 → 0.86mm BY981 (MLS), 1.72mm (30-028714-10) -0.92 → 0.96mm	DV150▲ (21-27540-20/0)	EV150 (22-25198-02/0)
XUD11ATE (PJZ)	2088	4	85.00		80/109				
XUD11ATE (P8A)/ XUD11ATE (PHZ)	2088	4	85.00		80-81/ 109- 110				
XUD11BTE (P8C)	2088	4	85.00		81/110				
XM 2.1L TD 12V Diesel				05/94 → 10/00		213	BY941 (MLS), 1.52mm (30-027543-20) -0.65 → 0.76mm BY961 (MLS), 1.62mm (30-028712-10) -0.82 → 0.86mm BY981 (MLS), 1.72mm (30-028714-10) -0.92 → 0.96mm	DV150▲ (21-27540-20/0)	EV150 (22-25198-02/0)
XUD11ATE (PJZ)	2088	4	85.00		80/109				
XUD11ATE (P8A)/ XUD11ATE (PHZ)	2088	4	85.00		80-81/ 109- 110				
XUD11BTE (P8C)	2088	4	85.00		81/110				
XM 2.5L TD Diesel				05/94 → 10/00		214	BY140 (Fibre) (30-029752-00)	DY140▲ (21-29752-20/0)	EY140 (22-29752-00/0)
DK5ATE (THY)	2446	4	92.00		95/129				
XM 3.0L V6				05/89 → 10/00		215			
XM 3.0L V6 24V				07/90 → 10/00					
ZPJ/Z (SFZ)/ZPJ/Z (UFZ)	2963	6	93.00	MPI, V6	123- 125/ 167- 170				
ZPJ4 (SKZ)/ZPJ4 (UKZ)	2963	6	93.00	MPI	147/200				
XM 3.0L V6				04/97 → 10/00		216	AG9710 (MLS), 1.40mm AG9720 (MLS), 1.65mm AG9730 (MLS), 1.40mm AG9740 (MLS), 1.65mm	CG9720 CG9740	EG9710
ES9J4 (XFZ)	2946	6	87.00	MPI, V6	152/207				
Xsara 1.4L HDI Diesel				01/03 → 08/05		217	AD5130 (MLS), 1.25mm, 2 Notches, +3 Notches (30-029277-00)	CD5130▲ (21-29277-00/0)	ED5130
Xsara Coupe 1.4L HDI Diesel				01/03 → 03/05			AD5140 (MLS), 1.30mm, 3 Notches, +3 Notches (30-029278-00)		
DV4TD (8HX)	1398	4	73.70	Common Rail, SOHC	52/71		AD5150 (MLS), 1.35mm, 1 Notch, +3 Notches (30-029279-00)		
							AD5160 (MLS), 1.40mm, +3 Notches, 4 Notches (30-029280-00)		
							AD5170 (MLS), 1.45mm, +3 Notches, 5 Notches (30-029281-00)		
Xsara 1.4L i				04/97 → 08/05		218	AD5700 (Fibre), 1.25mm (30-026851-00)	DT012▲ (21-26853-20/0)	EH951 [8] (22-25605-00/0)
Xsara Coupe 1.4L i				03/98 → 03/05			AD5710 (Fibre), 1.50mm [34] (30-029799-00)		
TU3JP (KFW)/TU3JP (KFX)	1360	4	75.00	MPI, SOHC	55/75				











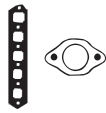

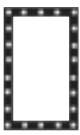

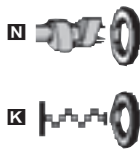













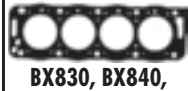



































































								
HBS115  (22-15006B) M12x1.50x145mm (x10) →Eng.05571 HBS125  (22-15007B) M12x1.50x150.5mm (x10) Eng.05572→	JD529  (31-027540-00) JD230 	JP045 (50-028922-00)	PA349 (33-102290-10) 22x16x2mm PB907 14x21x2mm	HR805 	NF841  35x50x8mm, FPM (50-319310-00) NA5191  42x62x7mm, PTFE (50-319500-00) NA5192  90x110x7mm, PTFE (50-319501-00)	HL5010 [245]  NF824 [38]  NF825 [38]  KA611 [13]	AD5130, AD5140, AD5150, AD5160, AD5170 AD5700, AD5710 BY140 BY930 JC702 JD230 JD529 JD532 JD538 JN658 JP045	
HBS115  (22-15006B) M12x1.50x145mm (x10) →Eng.05571 HBS125  (22-15007B) M12x1.50x150.5mm (x10) Eng.05572→	JD529  (31-027540-00) JD230 	JP045 (50-028922-00)	PA349 (33-102290-10) 22x16x2mm PB907 14x21x2mm	HR805 	NF841  35x50x8mm, FPM (50-319310-00) NA5191  42x62x7mm, PTFE (50-319500-00) NA5192  90x110x7mm, PTFE (50-319501-00)	HL5010 [245]  NF824 [38]  NF825 [38]  KA611 [13]	JC702 JD230 JD529 JD532 JD538	
HBS114  (22-15017B) M12x1.50x138mm (x14) M10x1.50x148mm (x8)	JD532  JD531  (31-029755-00)		JJ588 (31-029758-00) PA349 (33-102290-10) 22x16x2mm	HR788 	NB959  35x50x7mm, FPM (50-306644-50) NF866  64x88x6mm, FPM/ACM NF867  98x120x7mm, FPM/ACM	HL5027 [245]  NF881 [38]  NF882 [38] 	JD538	
HBS127  (22-15009B) M12x1.50x178mm (x16)		HR397 [57] 34-000410-00	PA349 (33-102290-10) 22x16x2mm		NF869 (x2) 32x45x8mm, MVQ NA5191  42x62x7mm, PTFE (50-319500-00) NF761  42x62x10mm, FPM/ACM (50-319355-00)		JN658 JP045	
HBS272  (22-53016B) M10x1.50x147mm (x16)	JD5879  JD5880  (Steel Elastomer) JD5878  (MLS)		PB852 16x24x1.5mm	HR5062  24-30614-73/0	NA5260 38x50x6mm			
HBS359  (22-15018B) M11x1.50x150mm (x10)	HA5029  (24-35042-80/0) JD5829  (31-030265-00)		KG5157 10x20x2mm		NA5258 27x47x7mm NA5259  40x55x6.4mm			
HBS039  (22-15010B) M10x1.50x175mm (x10)	JD538  (x4) (31-029472-00) JD5828  HA5028  JC702  (x2) (31-029804-00)  JE5072 (MLS)	JN658 (50-026853-00)	PB852 16x24x1.5mm	HR642 	NF817  36x50x7mm, FPM (50-319112-00) NF870  42x66x6mm, FPM/ACM (50-319113-00) NF857  85x105x9mm, FPM/ACM (50-319478-00)	HL5011 [245]  HR564 [37]  NA5205 [38]  NA5204 [38]  PA850 [13]		



KW/PS



Xsara 1.5L D Diesel		04/97 → 09/00		219	BY150 (Fibre), 1.75mm (30-028755-00)	CY140▲	
TUD5 (VJZ)	1527	4	77.00	42/57			
Xsara 1.6L		09/00 →		220	BY180 (Fibre), 1.37mm (30-028756-00)	DY130▲ (21-26853-21/0)	EY130 (22-28758-00/0)
Xsara 1.6L i		04/97 → 09/00			AY120 (Fibre), 1.57mm [34] (30-029801-00)		
Xsara Coupe 1.6L i		02/98 → 09/00					
Xsara Picasso 1.6L		06/00 →					
	1587	4		67/91			
	1587	4		70/95			
TU5JP (NFT/NFZ)	1587	4	78.50	66/89			
Xsara 1.6L 16V		09/00 → 08/05		221	AD5180 (MLS), 0.62mm (30-029785-00)	CD5180 (21-29785-20/0)	ED5180
Xsara Coupe 1.6L 16V		09/00 → 03/05					
Xsara Picasso 1.6L 16V		09/05 →					
TU5JP4 (NFU/N6A)	1587	4	78.50	80/109			
Xsara 1.6L HDI Diesel		09/05 →		222	AD5130 (MLS), 1.25mm, 2 Notches, +3 Notches (30-029277-00) AD5140 (MLS), 1.30mm, 3 Notches, +3 Notches (30-029278-00) AD5150 (MLS), 1.35mm, 1 Notch, +3 Notches (30-029279-00) AD5160 (MLS), 1.40mm, +3 Notches, 4 Notches (30-029280-00) AD5170 (MLS), 1.45mm, +3 Notches, 5 Notches (30-029281-00)	CD5140▲ (21-29278-00/0)	
	1560	4		66/90			
Xsara Picasso 1.6L HDI Diesel		05/04 →		223	AD5130 (MLS), 1.25mm, 2 Notches, +3 Notches (30-029277-00) AD5140 (MLS), 1.30mm, 3 Notches, +3 Notches (30-029278-00) AD5150 (MLS), 1.35mm, 1 Notch, +3 Notches (30-029279-00) AD5160 (MLS), 1.40mm, +3 Notches, 4 Notches (30-029280-00) AD5170 (MLS), 1.45mm, +3 Notches, 5 Notches (30-029281-00)	CD5140▲ (21-29278-00/0)	
DV6TED4	1560	4	75.00	80/109			
Xsara 1.8L D Diesel		04/97 → 09/00		224	BX830 (Fibre), 1.36mm, 1 Notch (30-028484-00) ☞0.56 → 0.67mm BX840 (Fibre), 1.40mm, 2 Notches (30-028485-00) ☞0.68 → 0.71mm BX850 (Fibre), 1.44mm, 3 Notches (30-028486-00) ☞0.72 → 0.75mm BX860 (Fibre), 1.48mm, 4 Notches (30-028487-00) ☞0.76 → 0.79mm BX870 (Fibre), 1.52mm, 5 Notches (30-028488-00) ☞0.80 → 0.83mm	DJ720▲ (21-25202-22/0)	EL890 (22-25198-01/0) GJ720▲ (20-25202-02/0)
XUD7 (161A)/XUD7 (A9A/161A)	1769	4	80.00	44/60			











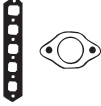

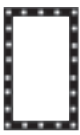

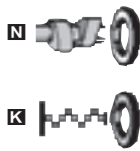

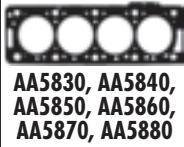



























































								 AD5130, AD5140, AD5150, AD5160, AD5170
HBS113  (22-15015B) M11x1.50x185mm (x10)	 JE189 (31-029805-00)	JP041 (50-028757-00)	JJ587  PB907 14x21x2mm	HR642 	 NF817 36x50x7mm, FPM (50-319112-00)  NF870 42x66x6mm, FPM/ACM (50-319113-00)  NF857 85x105x9mm, FPM/ACM (50-319478-00)	HL5011 [245]  NA5205 [38]  NA5204 [38]  PB259 [14]	 AD5180  AY120  BX830, BX840, BX850, BX860, BX870	
HBS039  (22-15010B) M10x1.50x175mm (x10)	JD530  (x4) JC702  (x2) (31-029804-00)	JN658 (50-026853-00)	JJ587  PB852 16x24x1.5mm  PA349 (33-102290-10) 22x16x2mm	HR642 	 NF817 36x50x7mm, FPM (50-319112-00)  NF870 42x66x6mm, FPM/ACM (50-319113-00)  NF857 85x105x9mm, FPM/ACM (50-319478-00)	HL5011 [245]  NA5205 [38]  NA5204 [38] 	 BY150  BY180	
HBS254  (22-53009B) M10x1.50x122mm (x10)	HA5032   (24-35043-10/0) JD5831   JE5072 (MLS)	JM7035 (50-030267-00)	JH5107 (ACM)  PB852 16x24x1.5mm  PA349 (33-102290-10) 22x16x2mm		 NA5260 38x50x6mm  NF870 42x66x6mm, FPM/ACM (50-319113-00)  NF857 85x105x9mm, FPM/ACM (50-319478-00)	HL5038 [245]  NA5205 [38]  NA5204 [38] 	 JC702  JC759  JE189	
HBS359  (22-15018B) M11x1.50x150mm (x10)	JD5830   (50-030266-00) HA5030     (24-35042-90/0) HA5031     (24-35043-00/0) JD5829  (31-030265-00)	JM7034 (50-030264-00)	 KG5157 10x20x2mm		 NA5258 27x47x7mm  NA5259 40x55x6.4mm	HL5033 [245] 	 JN544  JN658  JP041	
HBS359  (22-15018B) M11x1.50x150mm (x10)	JD5830   (50-030266-00) HA5031    (24-35043-00/0) HA5030    (24-35042-90/0) JD5829  (31-030265-00)	JM7034 (50-030264-00)	 KG5157 10x20x2mm		 NA5258 27x47x7mm  NA5259 40x55x6.4mm	HL5033 [245] 	 JJ283  KA611 [13]	
HBS084  (22-15005B) M12x1.50x123mm (x10) →Eng.08469 HBS245  (22-53008B) M12x1.50x125mm (x10) Eng.08470 →	JC759 [60] (31-028417-00) (Steel)	JN544 (50-025202-00)	JJ283 [6] (31-025198-10)  PA349 (33-102290-10) 22x16x2mm  PB907 14x21x2mm	HR569  24-30667-00/0	 NB959 35x50x7mm, FPM (50-306644-50)  NA5191 42x62x7mm, PTFE (50-319500-00)  NA5192 90x110x7mm, PTFE (50-319501-00)	HL5012 [245]  NA5205 [38]  NA5204 [38]  KA611 [13]	 JJ587	



KW/PS



Xsara 1.8l i		04/97 → 09/00		225		BL650 (Fibre), 1.20mm (30-026859-10)	DL651▲ (21-28759-22/0)	EL650 (22-25198-00/0)
Xsara Coupe 1.8l i		02/98 → 09/00				BR510 (Fibre), 1.44mm [34] (30-026858-10)		
XU7JB (LFX)	1761	4	83.00	MPi	66/89			
Xsara 1.8l i 16V		04/97 → 09/00		226		AD5100 (Fibre)	CD5100 → Eng.7965	
Xsara Coupe 1.8l i 16V		02/98 → 09/00						
XU7JP4 (LFY)	1761	4	83.00	MPi	66/85/ 90/116			
Xsara 1.8l i Aut.		04/97 → 09/00		227		BL650 (Fibre), 1.20mm (30-026859-10)	CY130▲ (21-28759-20/0)	EL650 (22-25198-00/0)
Xsara Coupe 1.8l i		02/98 → 09/00				BR510 (Fibre), 1.44mm [34] (30-026858-10)		
XU7JP (LFW/LFZ/L6A)	1761	4	83.00	MPi	73/99			
Xsara 1.8L TD Diesel		10/97 → 09/00		228		BR780 (Fibre), 1.65mm, 2 Notches ☞ 0.65 → 0.77mm BR790 (Fibre), 1.80mm, 3 Notches (30-026855-10) ☞ 0.77 → 0.82mm	DJ720▲ (21-25202-22/0)	EL890 (22-25198-01/0) GJ720▲ (20-25202-02/0)
Xsara Picasso 1.8L 16V		02/00 →		229		AD5100 (Fibre)	CD5100	
EW7J4 (6FZ)	1749	4	82.70	MPi	85/115			
XU7JP4 (LFY)	1761	4	83.00	MPi	66/85/ 90/116			
Xsara 1.9L D Diesel		07/98 → 08/05		230		AA5830 (Steel Elastomer), 1.26mm, 1 Hole (30-029190-00) ☞ 0.51 → 0.54mm AA5840 (Steel Elastomer), 1.30mm, 2 Holes (30-029191-00) ☞ 0.55 → 0.58mm AA5850 (Steel Elastomer), 1.34mm, 3 Holes (30-029192-00) ☞ 0.59 → 0.62mm AA5860 (Steel Elastomer), 1.38mm, 4 Holes (30-029193-00) ☞ 0.63 → 0.66mm AA5870 (Steel Elastomer), 1.42mm, 5 Holes (30-029194-00) ☞ 0.67 → 0.70mm AA5880 (Steel Elastomer), 1.46mm, 6 Holes (30-029195-00) ☞ 0.71 → 0.75mm	CA5830▲ (21-29482-20/0)	EA5830
Xsara Coupe 1.9L D Diesel		02/99 → 03/05						
DW8 (WJZ) / DW8B (WJY)/DW8B (WJY)	1868	4	82.20	SOHC	51/70			











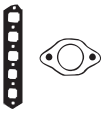

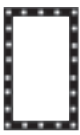

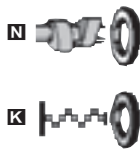





































								 AA5830, AA5840, AA5850, AA5860, AA5870, AA5880  BL650  BR780, BR790  JC759  JC991  JD519  JD520  JN544  JP043  JJ283
HBS260  (22-53011B) M11x1.50x168mm (x10)	JD520  (x4)	JP043 (50-028759-00)	PB907 14x21x2mm	HR569  24-30667-00/0	NF817 36x50x7mm, FPM (50-319112-00) NA5191  42x62x7mm, PTFE (50-319500-00) NA5192  90x110x7mm, PTFE (50-319501-00)	HL5019 [245]  HR566 [37]  NA5205 [38]  NA5204 [38]  KA611 [13]		
HBS089  (22-15016B) M11x1.50x159mm (x10)	JD5832 		PB907 14x21x2mm	HR5080  (24-30710-45/0) →Eng.07359 HR5081  (24-30721-87/0) Eng.07360 → →Eng.07965	NF817 36x50x7mm, FPM (50-319112-00) NA5191  42x62x7mm, PTFE (50-319500-00) NA5192  90x110x7mm, PTFE (50-319501-00)	HL5019 [245]  HR566 [37]  NA5205 [38]  NA5204 [38]  KA611 [13]		
HBS260  (22-53011B) M11x1.50x168mm (x10)	JD519  (x2) JD520  (x4)	JP043 (50-028759-00)	JJ283 [6] (31-025198-10) PB907 14x21x2mm	HR569  24-30667-00/0	NF817 36x50x7mm, FPM (50-319112-00) NA5191  42x62x7mm, PTFE (50-319500-00) NA5192  90x110x7mm, PTFE (50-319501-00)	HL5019 [245]  HR566 [37]  NA5205 [38]  NA5204 [38]  KA611 [13]		
HBS084  (22-15005B) M12x1.50x123mm (x10) →12/90 →Eng.5407 JC991 (31-028595-00) 01/91 → Eng.5408 →	JC759 [60] (31-028417-00) (Steel) →12/90 →Eng.5407 JC991 (31-028595-00) 01/91 → Eng.5408 →	JN544 (50-025202-00)	JJ283 [6] (31-025198-10) PA349 (33-102290-10) 22x16x2mm	HR569  24-30667-00/0	NF841 35x50x8mm, FPM (50-319310-00) NA5191  42x62x7mm, PTFE (50-319500-00) NA5192  90x110x7mm, PTFE (50-319501-00)	HL5010 [245]  NA5205 [38]  NA5204 [38]  KA611 [13]		
	JD5832  JD5833 		PB907 14x21x2mm	HR5080  (24-30710-45/0) →Eng.07359 HR5081  (24-30721-87/0) Eng.07360 → →Eng.07965	NF817 36x50x7mm, FPM (50-319112-00) NA5191  42x62x7mm, PTFE (50-319500-00) NA5256  40x55x6.5mm NA5192  90x110x7mm, PTFE (50-319501-00)	HL5019 [245]  HR566 [37]  NA5205 [38]  NA5204 [38]  KA611 [13]		
HBS084  (22-15005B) M12x1.50x123mm (x10) →Eng.08469 HBS245  (22-53008B) M12x1.50x125mm (x10) Eng.08470 →	HA5008   JD5192  (x2)	JM5088  JM5089 	KG5157 10x20x2mm PB907 14x21x2mm	HR569  24-30667-00/0	NB959 35x50x7mm, FPM (50-306644-50) NA5191  42x62x7mm, PTFE (50-319500-00) NA5192  90x110x7mm, PTFE (50-319501-00)	HL5012 [245]  NA5205 [38]  NA5204 [38] 		



KW/PS



Xsara 1.9L D Diesel		04/97 → 09/00		231		BX880 (Fibre), 1.36mm, 1 Notch (30-028475-00) →0.56 →0.67mm		DJ720▲ (21-25202-22/0)		EL890 (22-25198-01/0) GJ720▲ (20-25202-02/0)	
Xsara Coupe 1.9L D Diesel		02/98 → 09/00				BX890 (Fibre), 1.40mm, 2 Notches (30-028476-00) →0.68 →0.71mm					
Xsara 1.9L TD Diesel		01/98 → 09/00		232		BX930 (Steel Elastomer), 1.36mm, 1 Notch (30-028503-00)		DJ720▲ (21-25202-22/0)		EL890 (22-25198-01/0) GJ720▲ (20-25202-02/0)	
Xsara Coupe 1.9L TD Diesel		01/98 → 09/00				BX940 (Steel Elastomer), 1.40mm, 2 Notches (30-028504-00)					
Xsara 1.9L TD Diesel		04/97 → 09/00		233		BX950 (Steel Elastomer), 1.44mm, 3 Notches (30-028505-00)		DJ720▲ (21-25202-22/0)		EL890 (22-25198-01/0) GJ720▲ (20-25202-02/0)	
Xsara Coupe 1.9L TD Diesel		02/98 → 09/00				BX960 (Steel Elastomer), 1.48mm, 4 Notches (30-028506-00)					
Xsara 2.0L 16V		04/97 → 09/00		234		BX970 (Steel Elastomer), 1.52mm, 5 Notches (30-028507-00)		CY070			
Xsara Coupe 2.0L i 16V		02/98 → 03/05				BX980 (Steel Elastomer), 1.59mm →0.83mm →					
Xsara 2.0L 16V		09/00 → 08/05		235		AY070 (Fibre) (30-029744-00)		CD5300		ED5300	
Xsara Coupe 2.0L 16V		09/00 → 03/05									
Xsara Picasso 2.0L 16V		01/03 →									
XUD9A (DJY/D9B)	1905	4	83.00		51/70						
DHV (XUD9BSD)	1905	4	83.00	KE-Jetronic	55/75						
XUD9TE (DHY/D8A)	1905	4	83.00		44/66/ 60/90						
XU10J4R (RFV)	1998	4	86.00	MPi	99/135						
XU10J4RS (RFS)	1998	4	86.00	SPi	120/163						
EW10J4 (RFN)	1997	4	85.00	MPi, DOHC	100/136						











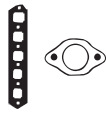

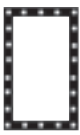

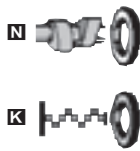

















































































								 AY070
HBS084  (22-15005B) M12x1.50x123mm (x10)	JC759 [60] (31-028417-00) (Steel)	JN544 (50-025202-00)	JJ283 [6] (31-025198-10) ● PA349 (33-102290-10) 22x16x2mm ● PB907 14x21x2mm	HR569  24-30667-00/0	NA959  35x50x7mm, FPM (50-306644-50) NA5191  42x62x7mm, PTFE (50-319500-00) NA5192  90x110x7mm, PTFE (50-319501-00)	HL5012 [245]  NA5205 [38]  NA5204 [38]  KA611 [13]	 BX880, BX890, BX900, BX910, BX920  BX930, BX940, BX950, BX960, BX970, BX980	
HBS084  (22-15005B) M12x1.50x123mm (x10)	JC759 [60] (31-028417-00) (Steel) JC991 (31-028595-00)	JN544 (50-025202-00)	JJ283 [6] (31-025198-10) ● PA349 (33-102290-10) 22x16x2mm ● PB907 14x21x2mm	HR569  24-30667-00/0	NA959  35x50x7mm, FPM (50-306644-50) NA5191  42x62x7mm, PTFE (50-319500-00) NA5192  90x110x7mm, PTFE (50-319501-00)	HL5012 [245]  NA5205 [38]  NA5204 [38]  KA611 [13]	 JN544  JJ283	
HBS088  (22-15014B) M12x1.50x145mm (x10) →Eng.08574 HBS277  (22-53018B) M12x1.50x148mm (x10) Eng.08575→	JC759 [60] (31-028417-00) (Steel)	JN544 (50-025202-00)	JJ283 [6] (31-025198-10) ● PA349 (33-102290-10) 22x16x2mm ● PB907 14x21x2mm	HR569  24-30667-00/0	NA959  35x50x7mm, FPM (50-306644-50) NA5191  42x62x7mm, PTFE (50-319500-00) NA5192  90x110x7mm, PTFE (50-319501-00)	HL5012 [245]  NA5205 [38]  NA5204 [38]  KA611 [13]		
HBS087  (22-15013B) M12x1.50x110mm (x10) →Eng.08581 HBS278  (22-53019B) M12x1.50x110mm (x10) Eng.08582→	JD536 		● PB907 14x21x2mm	HR5080  (24-30710-45/0) →Eng.07359 HR5081  (24-30721-87/0) Eng.07360→ →Eng.07965	NF817  36x50x7mm, FPM (50-319112-00) Xantia, XM NA5191  42x62x7mm, PTFE (50-319500-00) NA5192  90x110x7mm, PTFE (50-319501-00)	HL5019 [245]  NA5205 [38]  NA5204 [38]  KA611 [13]		
HBS259  (22-53010B) M11x1.50x144.5mm (x10)	JD5833 	JM5283  JM5139 	● PB907 14x21x2mm		NA5256  40x55x6.5mm			



KW/PS



Xsara 2.0L HDI 109 Diesel				05/01 → 08/05	236	AC5011 (MLS), 1.30mm, 1 Hole ⊖0.47 → 0.605mm	CC5010▲ (21-29484-20/0) CC5011▲ Eng.8332 → RHZ	EA5830
Xsara 2.0L HDI 90 Diesel				02/99 → 08/05				
Xsara Coupe 2.0L HDI 109 Diesel				05/01 → 03/05				
Xsara Coupe 2.0L HDI 90 Diesel				02/99 → 03/05				
Xsara Picasso 2.0L HDI Diesel				12/99 →				
DW10TD (RHY)	1998	4	85.00	Common Rail	63/86	AC5051 (MLS), 1.50mm, 5 Holes (30-029481-10) ⊖0.655 → 0.705mm		
DW10ATED (RHZ)	1998	4	85.00	Common Rail	80/109	AC5051 (MLS), 1.50mm, 5 Holes (30-029481-10) ⊖0.755 → 0.83mm		
ZX 1.1L				03/91 → 06/97	237	AD5700 (Fibre), 1.25mm (30-026851-00) TU1M BS810 (Fibre), 1.30mm (30-026850-00) TU1M+ AD5710 (Fibre), 1.50mm [34] (30-029799-00) TU1M BR490 (Fibre), 1.50mm [34] (30-029800-00) TU1M+	DT010 (21-26851-20/0) TU1M DT012▲ (21-26853-20/0)	EH951 [8] (22-25605-00/0) EH952 (22-25605-02/0)
TU1M (H1A)	1124	4	72.00	Carburettor		40/54		
ZX 1.1L				03/91 → 08/93	238	AD5700 (Fibre), 1.25mm (30-026851-00) AD5710 (Fibre), 1.50mm [34] (30-029799-00)	DT010 (21-26851-20/0) DT012▲ (21-26853-20/0)	EH951 [8] (22-25605-00/0) EH952 (22-25605-02/0)
TU1 (H1A)	1124	4	72.00	Carburettor		40-44/ 54-60		
TU1 (H1B)	1124	4	72.00	Injection, SOHC	40-44/ 55-60			
ZX 1.4L				03/91 → 06/97	239	AD5700 (Fibre), 1.25mm (30-026851-00) BY130 (Fibre), 1.28mm (30-029099-00) AD5710 (Fibre), 1.50mm [34] (30-029799-00)	DT010 (21-26851-20/0) DT012▲ (21-26853-20/0)	EH951 [8] (22-25605-00/0) EH952 (22-25605-02/0)
TU3M/Z (KDZ)	1360	4	75.00	SPi, SOHC		55/75		
ZX 1.4L				08/91 → 12/96	240	BY130 (Fibre), 1.28mm (30-029099-00) BY170 (Fibre), 1.50mm [34]	DY130▲ (21-26853-21/0)	EY130 (22-28758-00/0)
TU3A (K1H)/TU3F2 (K1F)	1360	4	75.00	Carburettor		62/84		
TU3F2 (K2B)	1360	4	75.00	Carburettor, Cast iron head		62/84		
TU3FM (K2A)	1360	4	75.00	SPi, Cast iron head		62/84		
ZX 1.4L				09/86 → 08/94	241	AD5700 (Fibre), 1.25mm (30-026851-00) AD5710 (Fibre), 1.50mm [34] (30-029799-00)	DT010 (21-26851-20/0) DT012▲ (21-26853-20/0)	EH951 [8] (22-25605-00/0)
TU3CP (KAY)	1360	4	75.00	Carburettor		44/60		
ZX 1.4L D Diesel				09/88 → 06/92	242	BS730 (Steel Elastomer), 1.80mm (30-026845-20) BY120 (Fibre), 1.80mm (30-029802-00)	DS731▲ (21-26844-21/0)	EH951 [8] (22-25605-00/0)
TUD3 (K9A/K9Y)/TUD3 (K9Y)	1360	4	75.00	SOHC		39/53		











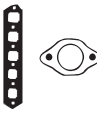























































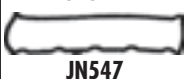















































								
HBS261  [22-53014B] M12x1.50x131mm (x10)	JD5191  JD5190 	JM5087	KG5157 10x20x2mm PB907 14x21x2mm	HR5046 	NA5035 27x47x7mm, FPM (50-319474-00) NA5191  42x62x7mm, PTFE (50-319500-00) NA5192  90x110x7mm, PTFE (50-319501-00)	HL5016 [245]  NA5205 [38]  NA5204 [38] 	 AD5700, AD5710  BS730, BY120  BS810, BR490  BY130  BY170  JC702  JD551  JE189  JF067  JN658  JN758  JJ586  JJ587	
HBS039  [22-15010B] M10x1.50x175mm (x10)	JD551  (x2) (31-029803-00) JC702  (x2) (31-029804-00) JE189  (31-029805-00)	JN658 (50-026853-00)	JJ586 (31-029806-00) PB852 16x24x1.5mm PA349 (33-102290-10) 22x16x2mm	HR642 	NF817 36x50x7mm, FPM (50-319112-00) NF870  42x66x6mm, FPM/ACM (50-319113-00) NF857  85x105x9mm, FPM/ACM (50-319478-00)	HL5011 [245]  HR564 [37]  NF836 [38]  NF826 [38]  PA850 [13] PA858 [13]		
HBS039  [22-15010B] M10x1.50x175mm (x10)	JD551  (x2) (31-029803-00) JC702  (x2) (31-029804-00) JE189  (31-029805-00)	JN658 (50-026853-00)	JJ586 (31-029806-00) PB852 16x24x1.5mm PA349 (33-102290-10) 22x16x2mm	HR642 	NF817 36x50x7mm, FPM (50-319112-00) NF870  42x66x6mm, FPM/ACM (50-319113-00) NF857  85x105x9mm, FPM/ACM (50-319478-00)	HL5011 [245]  HR564 [37]  NF836 [38]  NF826 [38]  PA850 [13] PA858 [13]		
HBS039  [22-15010B] M10x1.50x175mm (x10)	JD551  (x2) (31-029803-00) JC702  (x2) (31-029804-00) JE189  (31-029805-00)	JN658 (50-026853-00)	JJ586 (31-029806-00) PB852 16x24x1.5mm PA349 (33-102290-10) 22x16x2mm	HR642 	NF817 36x50x7mm, FPM (50-319112-00) NF870  42x66x6mm, FPM/ACM (50-319113-00) NF857  85x105x9mm, FPM/ACM (50-319478-00)	HL5011 [245]  HR564 [37]  NF836 [38]  NF826 [38]  PA850 [13] PA858 [13]		
HBS039  [22-15010B] M10x1.50x175mm (x10)	JC702  (x2) (31-029804-00) JE189  (31-029805-00)	JN658 (50-026853-00)	JJ587 PB852 16x24x1.5mm	HR642 	NF817 36x50x7mm, FPM (50-319112-00) NF870  42x66x6mm, FPM/ACM (50-319113-00) NF857  85x105x9mm, FPM/ACM (50-319478-00)	HL5011 [245]  HR564 [37]  NA5205 [38]  NF836 [38]  NA5204 [38]  NF826 [38] 		
HBS039  [22-15010B] M10x1.50x175mm (x10)	JC702  (x2) (31-029804-00) JE189  (31-029805-00)	JN658 (50-026853-00)	JJ586 (31-029806-00) PB852 16x24x1.5mm	HR569  24-30667-00/0 HR642 	NF817 36x50x7mm, FPM (50-319112-00) NF870  42x66x6mm, FPM/ACM (50-319113-00) NF857  85x105x9mm, FPM/ACM (50-319478-00)	HL5011 [245]  HR564 [37]  NA5205 [38]  NF836 [38]  NA5204 [38]  NF826 [38]  PA850 [13]		
HBS082  [22-15001B] M10x1.50x185mm (x10)	JF067 	JN758	JJ586 (31-029806-00) PA349 (33-102290-10) 22x16x2mm	HR642 	NF817 36x50x7mm, FPM (50-319112-00) NF870  42x66x6mm, FPM/ACM (50-319113-00) NF857  85x105x9mm, FPM/ACM (50-319478-00)	HL5011 [245]  HR564 [37]  NA5205 [38]  NF836 [38]  NA5204 [38]  NF826 [38]  PA850 [13] PB259 [14]		



KW/PS



ZX 1.4L i				03/91 → 10/97	243	AD5700 (Fibre), 1.25mm (30-026851-00)		DT010 (21-26851-20/0)	EH951 [8] (22-25605-00/0)
TU3JP (KFX)	1360	4	75.00	MPi, SOHC	55/75				
TU3M (KDX)/ TU3M (KDY)/TU3M/Z (KDZ)	1360	4	75.00	SPi, SOHC	55/75	AD5710 (Fibre), 1.50mm [34] (30-029799-00)		DT012▲ (21-26853-20/0)	EH952 (22-25605-02/0) TU3M
ZX 1.5L D Diesel				08/94 → 12/97	244	BY150 (Fibre), 1.75mm (30-028755-00) → Eng.07616		DY150▲ (21-28757-20/0)	
TUD5 (VJY)/TUD5 (VJZ)	1527	4	77.00		42/57				
ZX 1.6L				05/96 →	245	BY180 (Fibre), 1.37mm (30-028756-00)		DY130▲ (21-26853-21/0)	EY130 (22-28758-00/0)
TU5JP (NFT/NFZ)	1587	4	78.50	MPi	66/89	AY120 (Fibre), 1.57mm [34] (30-029801-00)			
ZX 1.6L i				03/91 → 10/97	246	BL650 (Fibre), 1.20mm (30-026859-10)		CY130▲ (21-28759-20/0)	EL650 (22-25198-00/0)
XU5JP (BFZ)	1580	4	83.00	MPi	65/88	BR510 (Fibre), 1.44mm [34] (30-026858-10)		XU5JP	GL650 XU5M
XU5M (BDY/B4A)	1580	4	83.00	SPi	65/88			DN590▲ (21-25204-21/0)	XU5M
ZX 1.8L D Diesel				06/93 → 10/97	247	BX830 (Fibre), 1.36mm, 1 Notch (30-028484-00) ☞ 0.56 → 0.67mm		DJ720▲ (21-25202-22/0)	EL890 (22-25198-01/0)
XUD7 (161A)	1769	4	80.00		44/60	BX840 (Fibre), 1.40mm, 2 Notches (30-028485-00) ☞ 0.68 → 0.71mm			GJ720▲ (20-25202-02/0)
						BX850 (Fibre), 1.44mm, 3 Notches (30-028486-00) ☞ 0.72 → 0.75mm			
						BX860 (Fibre), 1.48mm, 4 Notches (30-028487-00) ☞ 0.76 → 0.79mm			
						BX870 (Fibre), 1.52mm, 5 Notches (30-028488-00) ☞ 0.80 → 0.83mm			
ZX 1.8L i				07/92 → 10/97	248	BL650 (Fibre), 1.20mm (30-026859-10)		CY130▲ (21-28759-20/0)	EL650 (22-25198-00/0)
XU7JP (LFW/LFZ/L6A)	1761	4	83.00	MPi	73/99	BR510 (Fibre), 1.44mm [34] (30-026858-10)			











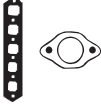

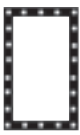

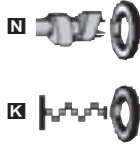



















































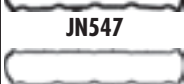













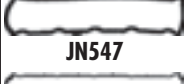















								
HBS039  [22-15010B] M10x1.50x175mm (x10)	JD538  (x4) (31-029472-00) TU3JP JD551  (x2) (31-029803-00) TU3M HA5028  JC702  (x2) (31-029804-00)  JE189 (31-029805-00) TU3M  JE5072 (MLS)	JN658 (50-026853-00)	JJ586 (31-029806-00) TU3M  PB852 16x24x1.5mm  PA349 (33-102290-10) 22x16x2mm	HR642 	 NF817 36x50x7mm, FPM (50-319112-00)  NF870 42x66x6mm, FPM/ACM (50-319113-00)  NF857 85x105x9mm, FPM/ACM (50-319478-00)	HL5011 [245]  HR564 [37]  NF836 [38]  NF826 [38]  PA850 [13] PA858 [13]	 AD5700, AD5710  JP041  JP043  AY120  BL650  BX830, BX840, BX850, BX860, BX870  BY150  JJ283  JJ586  JJ587	
HBS113  [22-15015B] M11x1.50x185mm (x10)		JP041 (50-028757-00)	JJ587  PB907 14x21x2mm	HR642 	 NF817 36x50x7mm, FPM (50-319112-00)  NF870 42x66x6mm, FPM/ACM (50-319113-00)  NF857 85x105x9mm, FPM/ACM (50-319478-00)	HL5011 [245]  NA5205 [38]  NF836 [38]  NA5204 [38]  NF826 [38]  PB259 [14]	 BY180  JC415  JC423  JC702  JC750  JC759  JD519  JD520  JD538  JD551  JE189  JN544  JN547  JN658	
HBS039  [22-15010B] M10x1.50x175mm (x10)	JD530  (x4) JC702  (x2) (31-029804-00)	JN658 (50-026853-00)	JJ587  PB852 16x24x1.5mm  PA349 (33-102290-10) 22x16x2mm	HR642 	 NF817 36x50x7mm, FPM (50-319112-00)  NF870 42x66x6mm, FPM/ACM (50-319113-00)  NF857 85x105x9mm, FPM/ACM (50-319478-00)	HL5011 [245]  NA5205 [38]  NF836 [38]  NA5204 [38]  NF826 [38] 		
HBS038  [22-15003B] M11x1.50x175mm (x10) HBS083  [22-15002B] M11x1.50x168mm (x10) HBS260  [22-53011B] M11x1.50x168mm (x10)	JC750  XU5M JD519  (x2) XU5JP JC415  (x4) (31-025205-20) JD520  (x4) XU5JP	JN547 (50-025204-10) XU5M JP043 (50-028759-00) XU5JP	JJ283 [6] (31-025198-10)  PA349 (33-102290-10) 22x16x2mm  PB907 14x21x2mm	HR642  24-30667-00/0	 NF817 36x50x7mm, FPM (50-319112-00)  NA5191 42x62x7mm, PTFE (50-319500-00)  NA5192 90x110x7mm, PTFE (50-319501-00)	HL5019 [245]  HR566 [37]  NF836 [38]  NF826 [38]  KA611 [13]		
HBS084  [22-15005B] M12x1.50x123mm (x10) → Eng.08469 HBS245  [22-53008B] M12x1.50x125mm (x10) Eng.08470 →	JC759 [60] (31-028417-00) (Steel) JC423  (x2) (31-025199-10)	JN544 (50-025202-00)	JJ283 [6] (31-025198-10)  PA349 (33-102290-10) 22x16x2mm  PB907 14x21x2mm	HR569  24-30667-00/0	 NF841 35x50x8mm, FPM (50-319310-00) → 01/94  NB959 35x50x7mm, FPM (50-306644-50) 02/94 →  NA5191 42x62x7mm, PTFE (50-319500-00)  NA5192 90x110x7mm, PTFE (50-319501-00)	HL5010 [245]  HL5012 [245]  NF836 [38]  NF826 [38]  KA611 [13]		
HBS260  [22-53011B] M11x1.50x168mm (x10)	JD519  (x2) JD520  (x4)	JP043 (50-028759-00)	JJ283 [6] (31-025198-10)  PB907 14x21x2mm	HR569  24-30667-00/0	 NF817 36x50x7mm, FPM (50-319112-00)  NA5191 42x62x7mm, PTFE (50-319500-00)  NA5192 90x110x7mm, PTFE (50-319501-00)	HL5019 [245]  HR566 [37]  NF836 [38]  NF826 [38]  KA611 [13]		



KW/PS



ZX 1.8L i 16V					01/96 → 02/98	249	AD5100 (Fibre)	CD5100 → Eng.7965	
XU7JP4 (LFY)	1761	4	83.00	MPi		66/85/ 90/116			
ZX 1.9L D Diesel					03/91 → 10/97	250	BX880 (Fibre), 1.36mm, 1 Notch (30-028475-00) → 0.56 → 0.67mm BX890 (Fibre), 1.40mm, 2 Notches (30-028476-00) → 0.68 → 0.71mm BX900 (Fibre), 1.44mm, 3 Notches (30-028477-00) → 0.72 → 0.75mm BX910 (Fibre), 1.48mm, 4 Notches (30-028478-00) → 0.76 → 0.79mm BX920 (Fibre), 1.52mm, 5 Notches (30-028479-00) → 0.80 → 0.83mm	DJ720▲ (21-25202-22/0)	EL890 (22-25198-01/0) GJ720▲ (20-25202-02/0)
XUD9 (DJZ/D9B/DJY) XUD9A/U (D9B)	1905 1905	4 4	83.00 83.00	MPi SOHC		52/71 66/90			
ZX 1.9L i					03/91 → 06/97	251	BL650 (Fibre), 1.20mm (30-026859-10) BR510 (Fibre), 1.44mm [34] (30-026858-10)	DN590▲ (21-25204-21/0)	EL650 (22-25198-00/0) GL650
XU9JA (DKZ)	1905	4	83.00	MPi		90/122			
ZX 1.9L TD Diesel					07/92 → 10/97	252	BX930 (Steel Elastomer), 1.36mm, 1 Notch (30-028503-00) BX940 (Steel Elastomer), 1.40mm, 2 Notches (30-028504-00) BX950 (Steel Elastomer), 1.44mm, 3 Notches (30-028505-00) BX960 (Steel Elastomer), 1.48mm, 4 Notches (30-028506-00) BX970 (Steel Elastomer), 1.52mm, 5 Notches (30-028507-00) BX980 (Steel Elastomer), 1.59mm → 0.83mm →	DJ720▲ (21-25202-22/0)	EL890 (22-25198-01/0) GJ720▲ (20-25202-02/0)
XUD9TE (DHY/D8A)	1905	4	83.00			44/66/ 60/90			
ZX 2.0L i					07/92 → 06/97	253	BV140 (Fibre), 1.25mm (30-028760-00) BY320 (Fibre), 1.45mm [34]	CY080▲ (21-28759-21/0)	ES820 (22-25198-03/0)
XU10J2C (RFX)	1998	4	86.00	MPi		89-90/ 120- 122			
ZX 2.0L i 16V					07/92 → 06/97	254	AY090 (Fibre), 1.25mm (30-028762-00) AY100 (Fibre), 1.45mm [34]	CY090▲	ES820 (22-25198-03/0)
XU10J4 (RFT)/ XU10J4 (RFY)	1998	4	86.00	MPi, DOHC		112/152			

								
HBS089  (22-15016B) M11x1.50x159mm (x10)	JD536  JD5832 		●PB907 14x21x2mm	HR5080  (24-30710-45/0) →Eng.07359 HR5081  (24-30721-87/0) Eng.07360→ →Eng.07965	NA NF817 36x50x7mm, FPM (50-319112-00) NA5191  42x62x7mm, PTFE (50-319500-00) NA5192  90x110x7mm, PTFE (50-319501-00)	HL5019 [245]  HR566 [37]  NF836 [38]  NF826 [38]  KA611 [13]	 AY090, AY100  BL650  BV140, BY320  BX880, BX890, BX900, BX910, BX920  BX930, BX940, BX950, BX960, BX970, BX980	
HBS084  (22-15005B) M12x1.50x123mm (x10)	JC759 [60] (31-028417-00) (Steel) JC991 (31-028595-00)	JN544 (50-025202-00)	JJ283 [6] (31-025198-10) ●PA349 (33-102290-10) 22x16x2mm ●PB907 14x21x2mm	HR569  24-30667-00/0	NA NF841 35x50x8mm, FPM (50-319310-00) →01/94 NB959 35x50x7mm, FPM (50-306644-50) 02/94→ NA5191  42x62x7mm, PTFE (50-319500-00) NA5192  90x110x7mm, PTFE (50-319501-00)	HL5010 [245]  HL5012 [245]  NF836 [38]  NF826 [38]  KA611 [13]	 HA510  JC415  JC750  JC759  JC991  JD520  JD536  JN544  JN547  JP043  JP044  JJ283	
HBS038  (22-15003B) M11x1.50x175mm (x10) HBS083  (22-15002B) M11x1.50x168mm (x10)	JC750  JC415  (x4) (31-025205-20)	JN547 (50-025204-10)	JJ283 [6] (31-025198-10) ●PA349 (33-102290-10) 22x16x2mm ●PB907 14x21x2mm	HR569  24-30667-00/0	NA NF817 36x50x7mm, FPM (50-319112-00) NA5191  42x62x7mm, PTFE (50-319500-00) NA5192  90x110x7mm, PTFE (50-319501-00)	HL5019 [245]  HR566 [37]  NF836 [38]  NF826 [38] 	 JC759  JC991  JD520  JD536  JN544  JN547  JP043  JP044  JJ283	
HBS088  (22-15014B) M12x1.50x145mm (x10) →Eng.08574 HBS277  (22-53018B) M12x1.50x148mm (x10) Eng.08575→	JC759 [60] (31-028417-00) (Steel) JC991 (31-028595-00)	JN544 (50-025202-00)	JJ283 [6] (31-025198-10) ●PA349 (33-102290-10) 22x16x2mm ●PB907 14x21x2mm	HR569  24-30667-00/0	NA NF841 35x50x8mm, FPM (50-319310-00) →01/94 NB959 35x50x7mm, FPM (50-306644-50) 01/94→ NA5191  42x62x7mm, PTFE (50-319500-00) NA5192  90x110x7mm, PTFE (50-319501-00)	HL5010 [245]  HL5012 [245]  NF836 [38]  NF826 [38]  KA611 [13]	 JN544  JN547  JP043  JP044  JJ283	
HBS084  (22-15005B) M12x1.50x123mm (x10)	HA510   JD520  (x4)	JP043 (50-028759-00)	JJ283 [6] (31-025198-10) ●PA349 (33-102290-10) 22x16x2mm ●PB907 14x21x2mm	HR569  24-30667-00/0	NA NF817 36x50x7mm, FPM (50-319112-00) NA5191  42x62x7mm, PTFE (50-319500-00) NA5192  90x110x7mm, PTFE (50-319501-00)	HL5019 [245]  NF836 [38]  NF826 [38]  KA611 [13]	 JP044  JJ283	
HBS087  (22-15013B) M12x1.50x110mm (x10) →Eng.08581 HBS278  (22-53019B) M12x1.50x110mm (x10) Eng.08582→	JD536 	JP044 (50-028763-00)	JJ283 [6] (31-025198-10) ●PA349 (33-102290-10) 22x16x2mm ●PB907 14x21x2mm	HR642 	NA NF817 (x2) 36x50x7mm, FPM (50-319112-00) NA5191  42x62x7mm, PTFE (50-319500-00) NA5192  90x110x7mm, PTFE (50-319501-00)	HL5019 [245]  NF836 [38]  NF826 [38]  KA611 [13]	 JJ283	

CITROËN



KW/PS

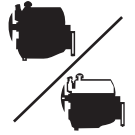

ZX 2.0L i 16V

05/96 → 06/97

255

AY070 (Fibre)
(30-029744-00)

CY070

XU10J4RS (RFS)











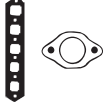

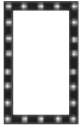



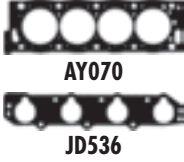

1998

4

86.00

SPi

120/163

							
<p>HBS087 </p> <p>(22-15013B)</p> <p>M12x1.50x110mm (x10)</p> <p>→Eng.08581</p> <p>HBS278 </p> <p>(22-53019B)</p> <p>M12x1.50x110mm (x10)</p> <p>Eng.08582 →</p>	<p>JD536 </p>		<p>PB907</p> <p>14x21x2mm</p>	<p>HR5080 </p> <p>(24-30710-45/0)</p> <p>→Eng.07359</p> <p>HR5081 </p> <p>(24-30721-87/0)</p> <p>Eng.07360 →</p> <p>→Eng.07965</p>	<p>NF817  36x50x7mm, FPM (50-319112-00) Xantia, XM</p> <p>NA5191  42x62x7mm, PTFE (50-319500-00)</p> <p>NA5192  90x110x7mm, PTFE (50-319501-00)</p>	<p>HL5019 [245] </p> <p>NF836 [38] </p> <p>NF826 [38] </p> <p>KA611 [13]</p>	



KW/PS

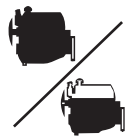

1300 1.3L		12/72 → 05/83			1	BT080 (Fibre), 1.50mm	DH686 ■ ▲ ○	EF380 [36] 01/76 → GT083 ■ ○ [36]
810-02/-99	1289	4	73.00		40/54			
1310 1.3L		05/83 →			2	BT080 (Fibre), 1.50mm	DH686 ■ ▲ ○	EF380 [36] 01/76 → GT083 ■ ○ [36]
810-02/-99	1289	4	73.00		40/54			
Logan 1.5L dCi Diesel		09/05 →			3	AE5200 (MLS) (30-029015-00) →12/05 AG9490 (MLS) (30-029497-00) 01/06 →		EE5200
K9K 790	1461	4	76.00	Direct Injection	48/65			
K9K 792	1461	4	76.00	Direct Injection, SOHC	50/68			
Logan 1.6L		09/04 →			4	BY030 (Fibre) (30-028797-00)	DY030 (21-28797-20/0)	EA220 (22-28798-00/0)
K7M 710	1598	4	79.50	SOHC	64/87			
Logan 1.6L 16V		02/06 →			5	BY030 (Fibre) (30-028797-00)	DY030 (21-28797-20/0)	EA220 (22-28798-00/0)
K4M 690	1598	4	79.50	Injection, DOHC	77/105			

		JN248 (50-026305-00)	HC354 ● KJ647 18.3x24x2mm		<input checked="" type="checkbox"/> NF535 30x42x8mm, NBR <input checked="" type="checkbox"/> NF834 35x50x8mm, FPM (50-319241-00) <input checked="" type="checkbox"/> NF722 35x50x10mm, MVQ	HR378 [37] NF541 (x2) [2] <input checked="" type="checkbox"/> NF814 (x2) [38] LT726 [13] NF545 [42] NF560 [15] JR635 [11]	 AE5200 BT080 BY030 JN248 JN789 HC354
		JN248 (50-026305-00)	HC354 ● KJ647 18.3x24x2mm		<input checked="" type="checkbox"/> NF535 30x42x8mm, NBR <input checked="" type="checkbox"/> NF834 35x50x8mm, FPM (50-319241-00) <input checked="" type="checkbox"/> NF722 35x50x10mm, MVQ	HR378 [37] NF541 (x2) [2] <input checked="" type="checkbox"/> NF814 (x2) [38] LT726 [13] NF545 [42] NF560 [15] JR635 [11]	 JN248 JN789 HC354
HBS299 (22-29019B) M11x1.50x125.0mm (x10)	JD5402 (31-030008-00)			HR817 24-30614-78/0	<input checked="" type="checkbox"/> NA5215 28x42x5mm, FPM <input checked="" type="checkbox"/> NA5255 35x47x7mm	HL5026 [245]	
HBS102 (22-51001B) M10x1.50x98mm (x5) M10x1.50x113mm (x5)	JD434 JD418	JN789 (31-026584-00)	● PA349 (33-102290-10) 22x16x2mm	HR646 24-30670-60/0	<input checked="" type="checkbox"/> NA5016 35x47x7mm, FPM (50-305690-50) <input checked="" type="checkbox"/> NF835 80x100x8mm, FPM/ACM (50-319239-00)	NF791 [38]	
HBS102 (22-51001B) M10x1.50x98mm (x5) M10x1.50x113mm (x5)	JD434 JD5393 JD418	JN789 (31-026584-00)	● PA349 (33-102290-10) 22x16x2mm	HR646 24-30670-60/0	<input checked="" type="checkbox"/> NA5016 35x47x7mm, FPM (50-305690-50) <input checked="" type="checkbox"/> NF835 80x100x8mm, FPM/ACM (50-319239-00)	NF791 [38]	



CC



9



CC



9







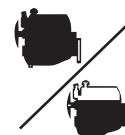



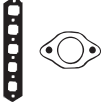

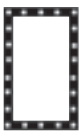

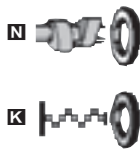





A14SMS	Petrol	1349	4	76.50	17
A15MF	Petrol	1498	4	76.50	2
A15MF	Petrol	1498	4	76.50	30
A15MF	Petrol	1498	4	76.50	31
A15SMS	Petrol	1498	4	76.50	18
A16DMS	Petrol	1598	4	79.00	19
A16DMS	Petrol	1598	4	79.00	35
A16DMS	Petrol	1598	4	79.00	37
A16DMS	Petrol	1598	4	79.00	39
C18LE	Petrol	1796	4	84.80	3
C18LE	Petrol	1796	4	84.80	32
C20LE	Petrol	1998	4	86.00	4
F14D3	Petrol	1399	4	77.90	11
F14D3	Petrol	1399	4	77.90	16
F14D3	Petrol	1399	4	77.90	33
F14D3	Petrol	1399	4	77.90	6
F16D3	Petrol	1598	4	79.00	34
F16D3	Petrol	1598	4	79.00	7
F16D3	Petrol	1598	4	79.00	8
F8C	Petrol	796	3	68.50	41
F8CV	Petrol	796	3	68.50	22
F8CV	Petrol	796	3	68.50	41
G15MF	Petrol	1498	4	76.50	29
L88	Petrol	1998	4	86.00	5
M 104.992	Petrol	3199	6	89.90	28
M 104.995	Petrol	3199	6	89.90	15
M 111.970	Petrol	2295	4	90.90	25
MB OM 601	Diesel	2299	4		24
MB-OM 601 29TD	Diesel	2874	5		14
MB-OM 601 29TD	Diesel	2874	5		27
MB-OM 662	Diesel	2874	5		13
MB-OM 662	Diesel	2874	5		26
T20SED	Petrol	1998	4	86.00	20
T20SED	Petrol	1998	4	86.00	36
X20SED	Petrol	1998	4	86.00	21
X20SED	Petrol	1998	4	86.00	36
X20SED	Petrol	1998	4	86.00	38
X20SED	Petrol	1998	4	86.00	40
X20SED	Petrol	1998	4	86.00	5
Y15L	Petrol	1498	4	84.80	18
Z20L	Petrol	1998	4	86.00	36



KW/PS



Espero 1.5L		02/95 → 09/99		1		BP800 (Fibre) (30-025706-20)	DP800 (21-25706-26/0)	EK484 [129] (22-27194-01/0)
	1498	4			55/75			
Espero 1.5L 16V		10/93 → 06/99		2		BZ300 (Fibre) (30-029687-00)		EK484 [129] (22-27194-01/0)
A15MF	1498	4	76.50	Injection	66/89			
Espero 1.8L		02/95 → 09/99		3		BP810 (Fibre) (30-025818-10)	DP810 (21-25818-22/0)	EK482 (22-26131-01/0)
C18LE	1796	4	84.80	Injection, SOHC	66-74/ 90-100			
Espero 2.0L		02/95 → 06/99		4		BP820 (Fibre) (30-025819-10)	DP820 (21-25819-21/0)	EK482 (22-26131-01/0)
C20LE	1998	4	86.00	Injection, SOHC	77/105			
Evanda 2.0L		08/02 →		5		BY250 (Fibre) (30-027987-10)	DY250 (21-27987-20/0)	
L88	1998	4	86.00		89-96/ 121- 131			
X20SED	1998	4	86.00	DOHC	100/136			
Gentra 1.4L		05/05 →		6		AG8000 (MLS)	CG8000	FG8000
Gentra 1.4L SR		05/03 → 04/05						
F14D3	1399	4	77.90	Injection, DOHC	70-69/ 95-94			
Gentra 1.6L E-Tec LS		05/05 →		7		AG8000 (MLS)		
F16D3	1598	4	79.00	Injection, DOHC	80-77/ 109- 105			
Gentra 1.6L E-Tec LS		05/05 →		8				
F16D3	1598	4	79.00	Injection, DOHC	80-77/ 109- 105			
Kalos 1.2L		04/03 →		9		AG7990 (Graphite) F12S3	CG7990	FG7990
	1150	4			53/72			
Kalos 1.4L		09/02 →		10		BP800 (Fibre) (30-025706-20)		
	1399	4			61/83			











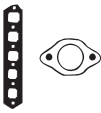

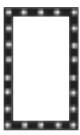

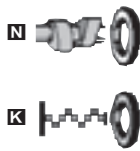

















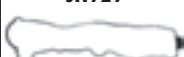





































								
HBS002 Ⓢ (22-29098B) M10x1.25x140mm (x10)	JC824 ■ (31-026334-00) ⓈJE120 (31-024767-00)	JN626 (31-026099-10)	JH5005 [116] (31-027194-00)	PA565 (x8) (50-305900-50) HR342 ■ (24-30590-05/0)	NC006 35x48x7mm, MVQ (50-319161-00) NB697 ■ 26x42x8mm, FPM (50-306704-00) NB698 ■ 80x98x10mm, FPM (50-319273-00)			 BP800  BP810  BP820  BY250  BZ300  JC282  JC756  JC757  JC824  JD5794  JE120  JN626  JN693  JH5005  JJ385
HBS285 Ⓢ (22-77001B) M10x1.25x166mm (x10)	JD5774 ■ (31-029644-00) (Graphite) JD5739 ■ (Fibre) JD5794 ■ (31-029643-00) (MLS)	HM5226 ■		NA5164 (x16) (50-307253-70) HR5092 ■ (24-30725-37/0)	NA5177 (x2) 42x56x7mm, FPM (50-319189-00) NB697 ■ 26x42x8mm, FPM (50-306704-00) NB698 ■ 80x98x10mm, FPM (50-319273-00)			
HBS053 Ⓢ (22-29099B) M11x1.25x140mm (x10)	JC757 ■ (31-025817-10) JC282 ■ (31-024625-20) ⓈJE120 (31-024767-00)	JN693 [128] (31-026198-10)	JJ385 [148] (50-026131-00)	PA565 (x8) (50-305900-50) HR342 ■ (24-30590-05/0)	NC006 ■ 35x48x7mm, MVQ (50-319161-00) NB807 ■ 55x70.1x8mm, FPM (50-306487-00) NB700 ■ 31x50x8mm, FPM (50-306551-50) NB806 ■ 90x104x11mm, FPM (50-306552-00)			
HBS003 Ⓢ (22-29009B) M11x1.25x140mm (x10)	JC756 ■ (31-025820-20) JC282 ■ (31-024625-20) ⓈJE120 (31-024767-00)	JN693 [128] (31-026198-10)	JJ385 [148] (50-026131-00)	PA565 (x8) (50-305900-50) HR342 ■ (24-30590-05/0)	NC006 ■ 35x48x7mm, MVQ (50-319161-00) NB807 ■ 55x70.1x8mm, FPM (50-306487-00) NB700 ■ 31x50x8mm, FPM (50-306551-50) NB806 ■ 90x104x11mm, FPM (50-306552-00)			
HBS054 Ⓢ (22-29013B) M11x1.25x105mm (x10)								
HBS002 Ⓢ (22-29098B) M10x1.25x140mm (x10)	JD5739 ■ (Fibre) JD5794 ■ (31-029643-00) (MLS)	JM5303	HR397 [57] 34-000410-00	NA5164 (x16) (50-307253-70)	NA5190 ■ 42x56x7mm, FPM (50-307352-70) NF812 ■ 30x42x8mm, ACM (50-319440-00) NB698 ■ 80x98x10mm, FPM (50-319273-00)			
			HR397 [57] 34-000410-00	NA5164 (x16) (50-307253-70)	NA5190 42x56x7mm, FPM (50-307352-70) NF812 ■ 30x42x8mm, ACM (50-319440-00) NB698 ■ 80x98x10mm, FPM (50-319273-00)			
				NA5164 (x16) (50-307253-70)	NA5177 (x2) 42x56x7mm, FPM (50-319189-00) NF812 ■ 30x42x8mm, ACM (50-319440-00) NB698 ■ 80x98x10mm, FPM (50-319273-00)			
		JM5302 F12S3						
HBS002 Ⓢ (22-29098B) M10x1.25x140mm (x10)								



KW/PS



Kalos 1.4L 05/03 → 12/04 11						AG8000 (MLS)	CG8000	FG8000
Kalos 1.4L 16V 04/03 →								
F14D3	1399	4	77.90	Injection, DOHC	70-69/ 95-94			
Korando 2.3L 01/99 → 12							DZ900 ■ ○ 21-27971-51/0	
	2295	4			105/143			
Korando 2.9L D Diesel 01/99 → 13						BW380 (Fibre), 1.80mm 30-026270-20	DW381 ■ ☒ ○ 21-28404-50/0	
Korando Cabrio 2.9L D Diesel 02/99 →								
MB-OM 662	2874	5			72-73/ 98-99			
Korando 2.9L TD Diesel 01/99 → 14						BW380 (Fibre), 1.80mm 30-026270-20	DW381 ■ ☒ ○ 21-28404-50/0	
Korando Cabrio 2.9L TD Diesel 02/99 →								
MB-OM 601 29TD	2874	5			88-95/ 120- 129			
Korando 3.2L 01/99 → 15						AE5330 (Fibre), 1.24mm 30-027354-30	CE5330 ○ 21-27354-51/0	
M 104.995	3199	6	89.90	Direct Injection	154- 156/ 209- 212			
Lacetti 1.4L 02/04 → 16						AG8000 (MLS)	CG8000	FG8000
F14D3	1399	4	77.90	Injection, DOHC	70-69/ 95-94			
Lanos 1.4L 05/97 → 17						BS260 (Fibre) (30-026329-10)	DS261 (21-26329-22/0)	ES260 [248] (22-27194-00/0)
A14SMS	1349	4	76.50	MPi, SOHC	55/75			
Lanos 1.5L 05/97 → 18						BS260 (Fibre) (30-026329-10)	DS261 (21-26329-22/0)	ES260 [248] (22-27194-00/0)
A15SMS	1498	4	76.50	MPi, SOHC	63/86			
Y15L	1498	4	84.80	SOHC	55/75			
Lanos 1.6L 16V 05/97 → 19						AB5230 (Fibre) (30-029642-00)	CB5230 (21-29642-20/0)	
A16DMS	1598	4	79.00	MPi, DOHC	78/106			
Leganza 2.0L 16V 07/00 → 20						BY250 (Fibre) (30-027987-10)		EC100 (22-27206-01/0) HC5007 (22-28386-00/0)
T20SED	1998	4	86.00	Injection, DOHC	93/126			







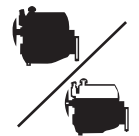



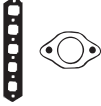

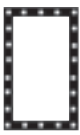

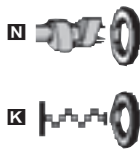





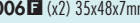













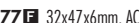











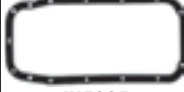























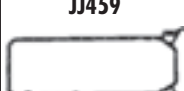







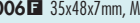

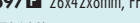

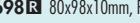



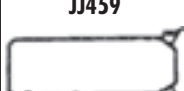







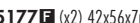

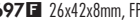

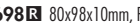
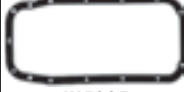





								
HBS002  (22-29098B) M10x1.25x140mm (x10)	JD5739  (Fibre) JD5794  (31-029643-00) (MLS)	JM5303	HR397 [57] 34-000410-00	NA5164 (x16) (50-307253-70)	NA5190  42x56x7mm, FPM (50-307352-70) NF812  30x42x8mm, ACM (50-319440-00) NB698  80x98x10mm, FPM (50-319273-00)			AB5230  AE5330  BS260  BW380  BY250  JC281  JC823  JD167  JD451  JD5794  JN929  JP016  JH5005  JJ500  JJ616  JJ617 
HBS150  (22-26009B) M12x1.75x102mm (x10)								
HBS059  (22-26006B) M10x1.50x80mm (x5) M10x1.50x115mm (x6) M10x1.50x102mm (x11)			KJ779 (33-110670-00)					
HBS059  (22-26006B) M10x1.50x80mm (x5) M10x1.50x115mm (x6) M10x1.50x102mm (x11)								
HBS152  (22-26071B) M12x1.75x160mm (x14)	JD167  50-027358-00 JD169  (31-026443-10)		JJ500 (31-026394-10)	HR5055  24-30704-45/0	NB971  45x67x10mm, FPM (50-305913-50) NB974  93x114x13mm, FPM (50-319192-00)		KK5683 [160]	
HBS002  (22-29098B) M10x1.25x140mm (x10)	JD5739  (Fibre) JD5794  (31-029643-00) (MLS)	JM5303	HR397 [57] 34-000410-00	NA5164 (x16) (50-307253-70)				
HBS002  (22-29098B) M10x1.25x140mm (x10)	JC823  (31-027191-10) JC281  (31-024312-10)	JN929 (50-027192-10)	JH5005 [116] (31-027194-00)	PA565 (x8) (50-305900-50) HR342  (24-30590-05/0)	NC006  35x48x7mm, MVQ (50-319161-00) NF812  30x42x8mm, ACM (50-319440-00) NB698  80x98x10mm, FPM (50-319273-00)			
HBS002  (22-29098B) M10x1.25x140mm (x10)	JC823  (31-027191-10) JC281  (31-024312-10)	JN929 (50-027192-10)	JH5005 [116] (31-027194-00)	PA565 (x8) (50-305900-50) HR342  (24-30590-05/0)	NC006  35x48x7mm, MVQ (50-319161-00) NF812  30x42x8mm, ACM (50-319440-00) NB698  80x98x10mm, FPM (50-319273-00)			
HBS285  (22-77001B) M10x1.25x166mm (x10)	JD5774  (31-029644-00) (Graphite) JD5739  (Fibre) JD5794  (31-029643-00) (MLS)	HM5227 	HR397 [57] 34-000410-00	NA5164 (x16) (50-307253-70) HR5092  (24-30725-37/0)	NA5177 (x2) 42x56x7mm, FPM (50-319189-00) NC006  35x48x7mm, MVQ (50-319161-00) NF812  30x42x8mm, ACM (50-319440-00) NB698  80x98x10mm, FPM (50-319273-00)			
HBS054  (22-29013B) M11x1.25x105mm (x10)	JD451  (31-027699-00)	JP016 (50-027683-00)	JJ616  (31-028386-00) JJ617  (31-028385-00)	HR791  24-30614-76/0	NC006  35x48x7mm, MVQ (50-319161-00) NB700  31x50x8mm, FPM (50-306551-50) NB806  90x104x11mm, FPM (50-306552-00)			

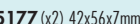

KW/PS

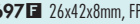

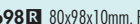
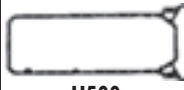
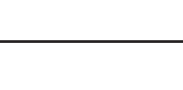
Model					Year Range	Code	Engine Type	Capacity	Power	Accessories
Leganza 2.0L 16V					06/97 → 12/02	21	BY250 (Fibre)	DY250	EC100	
X20SED	1998	4	86.00	DOHC	100/136	(30-027987-10)	(21-27987-20/0)	(22-27206-01/0)		
Matiz 0.8L					09/98 →	22	AD5690 (Fibre)	CD5690	ED5690	FD5690
F8CV	796	3	68.50	SOHC	38/52	(30-029654-00)	(21-29654-20/0)			
Matiz 1.0L					01/03 →	23		CG7990	FG7990	
	995	4			47/64					
Musso 2.2L TD Diesel					09/99 →	24		DW370		
MB OM 601	2299	4			74/101		21-27217-51/0			
Musso 2.3L					01/99 →	25	BZ900 (Fibre)	DZ900		
M 111.970	2295	4	90.90		103-110/ 140-150	30-027971-00	21-27971-51/0			
Musso 2.9L D Diesel					01/99 → 09/99	26	BW380 (Fibre), 1.80mm	DW381		
MB-OM 662	2874	5			72-73/ 98-99	30-026270-20	21-28404-50/0			
Musso 2.9L TD Diesel					01/99 →	27		DW381		
MB-OM 601 29TD	2874	5			88-95/ 120-129		21-28404-50/0			
Musso 3.2L					01/99 →	28	AE5330 (Fibre), 1.24mm	CE5330		
M 104.992	3199	6	89.90	Direct Injection, DOHC	162/220	30-027354-30	21-27354-51/0			
Nexia 1.5L					02/95 → 08/97	29	BP800 (Fibre)		EK484 [129]	
G15MF	1498	4	76.50		44-55/ 55-75	(30-025706-20)		(22-27194-01/0)		
Nexia 1.5L 16V					02/95 → 08/97	30	BZ300 (Fibre)		EK484 [129]	
A15MF	1498	4	76.50	Injection	66/89	(30-029687-00)		(22-27194-01/0)		
NEXIA 16V					02/95 → 08/97	31	BZ300 (Fibre)		EK484 [129]	
A15MF	1498	4	76.50	Injection	66/89	(30-029687-00)		(22-27194-01/0)		

								
HBS054  [22-29013B] M11x1.25x105mm (x10)	JD451  (31-027699-00) JD450  (31-027684-00)	JP016 (50-027683-00)	JJ459 [148] (31-027206-00)	HR791  24-30614-76/0	 NC006  (x2) 35x48x7mm, MVQ (50-319161-00)  NB700  31x50x8mm, FPM (50-306551-50)  NB806  90x104x11mm, FPM (50-306552-00)			 AD5690  AE5330  BP800
HBS377  [22-77004B] M10x1.25x97mm (x10)	JD5740  (50-029661-00) JE5034  (31-029655-00)	JM5263 (50-029656-00) (Rubber)		HR5075  [24-31945-40/0]	 NJ377  32x47x6mm, ACM  NJ337  60x80x8mm, NBR			 BW380  BY250  BZ300  BZ900  JC281  JC823  JD167  JD451  JD5794  JE120  JN626  JP016  JH5005  JJ459  JJ500
HBS377  [22-77004B] M10x1.25x97mm (x10)								
HBS058  [22-26069B] M10x1.50x80mm (x4) M10x1.50x115mm (x5) M10x1.50x102mm (x9)								
HBS150  [22-26009B] M12x1.75x102mm (x10)								
HBS059  [22-26006B] M10x1.50x80mm (x5) M10x1.50x115mm (x6) M10x1.50x102mm (x11)			 KJ779 (33-110670-00)					
HBS059  [22-26006B] M10x1.50x80mm (x5) M10x1.50x115mm (x6) M10x1.50x102mm (x11)								
HBS152  [22-26071B] M12x1.75x160mm (x14)	JD167  50-027358-00 JD169  (31-026443-10)		JJ500 (31-026394-10)	HR5055  24-30704-45/0	 NB971  45x67x10mm, FPM (50-305913-50)  NB974  93x114x13mm, FPM (50-319192-00)	KK5683 [160]		 JE120  JN626  JP016  JH5005  JJ459  JJ500
HBS002  [22-29098B] M10x1.25x140mm (x10)	JC823  (31-027191-10) JC281  (31-024312-10)  JE120 (31-024767-00)	JN626 (31-026099-10)	JH5005 [116] (31-027194-00)	PA565 (x8) (50-305900-50) HR342  (24-30590-05/0)	 NC006  35x48x7mm, MVQ (50-319161-00)  NB697  26x42x8mm, FPM (50-306704-00)  NB698  80x98x10mm, FPM (50-319273-00)			 JP016  JH5005  JJ459  JJ500
HBS285  [22-77001B] M10x1.25x166mm (x10)	JD5774  (31-029644-00) (Graphite) JD5739  (Fibre) JD5794  (31-029643-00) (MLS)	HM5226 		NA5164 (x16) (50-307253-70) HR5092  (24-30725-37/0)	 NA5177  (x2) 42x56x7mm, FPM (50-319189-00)  NB697  26x42x8mm, FPM (50-306704-00)  NB698  80x98x10mm, FPM (50-319273-00)			 JP016  JH5005  JJ459  JJ500
HBS285  [22-77001B] M10x1.25x166mm (x10)	JD5774  (31-029644-00) (Graphite) JD5739  (Fibre) JD5794  (31-029643-00) (MLS)	HM5226 		NA5164 (x16) (50-307253-70) HR5092  (24-30725-37/0)	 NA5177  (x2) 42x56x7mm, FPM (50-319189-00)  NB697  26x42x8mm, FPM (50-306704-00)  NB698  80x98x10mm, FPM (50-319273-00)			 JP016  JH5005  JJ459 JJ500



KW/PS



Model					Year Range	Power (KW/PS)	Engine Type	Accessories
Nexia 1.8L					10/95 → 08/97	32	BP810 (Fibre) (30-025818-10)	DP810 (21-25818-22/0) EK482 (22-26131-01/0)
C18LE	1796	4	84.00	Injection, SOHC	66-74/ 90-100			
Nubira 1.4L					10/03 → 12/04	33	AG8000 (MLS)	CG8000 FG8000
F14D3	1399	4	77.90	Injection, DOHC	70-69/ 95-94			
Nubira 1.6L					07/03 →	34	AG8000 (MLS)	
F16D3	1598	4	79.00	Injection, DOHC	80-77/ 109- 105			
Nubira 1.6L 16V					05/97 →	35	AB5230 (Fibre) (30-029642-00)	CB5230 (21-29642-20/0)
A16DMS	1598	4	79.00	MPI, DOHC	78/106			
Nubira 2.0L 16V					05/97 →	36	BY250 (Fibre) (30-027987-10)	DY250 (21-27987-20/0) EC100 (22-27206-01/0) HC5007 (22-28386-00/0)
T20SED	1998	4	86.00	Injection, DOHC	93/126			
X20SED	1998	4	86.00	DOHC	100/136			
Z20L	1998	4	86.00	Injection, DOHC				
Rezzo 1.6L					09/00 →	37	AB5230 (Fibre) (30-029642-00)	CB5230 (21-29642-20/0)
A16DMS	1598	4	79.00	MPI, DOHC	78/106			
Rezzo 2.0L					09/01 →	38	BY250 (Fibre) (30-027987-10)	DY250 (21-27987-20/0) EC100 (22-27206-01/0)
X20SED	1998	4	86.00	DOHC	100/136			
Tacuma 1.6L					05/97 →	39	AB5230 (Fibre) (30-029642-00)	CB5230 (21-29642-20/0)
A16DMS	1598	4	79.00	MPI, DOHC	78/106			
Tacuma Van 2.0L					06/97 →	40	BY250 (Fibre) (30-027987-10)	DY250 (21-27987-20/0) EC100 (22-27206-01/0) HC5007 (22-28386-00/0)
X20SED	1998	4	86.00	DOHC	100/136			

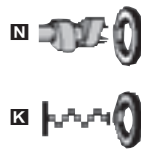
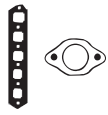

AB5230



BP810



BY250



JC757



JD451



JD5794



JE120

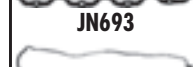

JN693



JP016



JJ385



JJ459

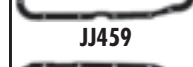

JJ616



JJ617

HBS003 Ⓢ (22-29009B) M11x1.25x140mm (x10)	JC757 ■ (31-025817-10) JE120 (31-024767-00)	JN693 [128] (31-026198-10)	JJ385 [148] (50-026131-00)	PA565 (x8) (50-305900-50) HR342 ■ (24-305900-50/0)	NC006 35x48x7mm, MVQ (50-319161-00) NB807 55x70.1x8mm, FPM (50-306487-00)	
HBS002 Ⓢ (22-29098B) M10x1.25x140mm (x10)	JD5739 ■ (Fibre) JD5794 ■ (31-029643-00) (MLS)	JM5303	HR397 [57] 34-000410-00	NA5164 (x16) (50-307253-70)	NA5190 ■ 42x56x7mm, FPM (50-307352-70) NF812 ■ 30x42x8mm, ACM (50-319440-00) NB698 ■ 80x98x10mm, FPM (50-319273-00)	
HBS285 Ⓢ (22-77001B) M10x1.25x166mm (x10) →12/05	JD5774 ■ (31-029644-00) (Graphite) JD5739 ■ (Fibre) JD5794 ■ (31-029643-00) (MLS)		HR397 [57] 34-000410-00	NA5164 (x16) (50-307253-70)	NA5190 42x56x7mm, FPM (50-307352-70) NF812 ■ 30x42x8mm, ACM (50-319440-00) NB698 ■ 80x98x10mm, FPM (50-319273-00)	
HBS285 Ⓢ (22-77001B) M10x1.25x166mm (x10)	JD5774 ■ (31-029644-00) (Graphite) JD5739 ■ (Fibre) JD5794 ■ (31-029643-00) (MLS)	HM5227 ■	HR397 [57] 34-000410-00	NA5164 (x16) (50-307253-70) HR5092 ■ (24-307253-70/0)	NA5177 (x2) 42x56x7mm, FPM (50-319189-00) NF812 ■ 30x42x8mm, ACM (50-319440-00) NB698 ■ 80x98x10mm, FPM (50-319273-00)	
HBS054 Ⓢ (22-29013B) M11x1.25x105mm (x10)	JD451 ■ (31-027699-00) JD450 ■ (31-027684-00)	JP016 (50-027683-00)	JJ459 [148] (31-027206-00) JJ616 ■ (31-028386-00) JJ617 ■ (31-028385-00)	HR791 ■ 24-30614-76/0	NC006 (x2) 35x48x7mm, MVQ (50-319161-00) NB700 ■ 31x50x8mm, FPM (50-306551-50) NB806 ■ 90x104x11mm, FPM (50-306552-00)	
HBS285 Ⓢ (22-77001B) M10x1.25x166mm (x10)	JD5774 ■ (31-029644-00) (Graphite) JD5739 ■ (Fibre) JD5794 ■ (31-029643-00) (MLS)	HM5227 ■		NA5164 (x16) (50-307253-70) HR5092 ■ (24-307253-70/0)	NA5177 (x2) 42x56x7mm, FPM (50-319189-00) NF812 ■ 30x42x8mm, ACM (50-319440-00) NB698 ■ 80x98x10mm, FPM (50-319273-00)	
HBS054 Ⓢ (22-29013B) M11x1.25x105mm (x10)	JD5774 ■ (31-029644-00) (Graphite) JD5739 ■ (Fibre) JD5794 ■ (31-029643-00) (MLS)			NA5164 (x16) (50-307253-70)	NA5177 42x56x7mm, FPM (50-319189-00) NF812 ■ 30x42x8mm, ACM (50-319440-00) NB698 ■ 80x98x10mm, FPM (50-319273-00)	
HBS285 Ⓢ (22-77001B) M10x1.25x166mm (x10)		HM5227 ■		NA5164 (x16) (50-307253-70) HR5092 ■ (24-307253-70/0)	NA5177 (x2) 42x56x7mm, FPM (50-319189-00) NF812 ■ 30x42x8mm, ACM (50-319440-00) NB698 ■ 80x98x10mm, FPM (50-319273-00)	
HBS054 Ⓢ (22-29013B) M11x1.25x105mm (x10)	JD451 ■ (31-027699-00) JD450 ■ (31-027684-00)	JP016 (50-027683-00)	JJ616 ■ (31-028386-00) JJ617 ■ (31-028385-00)	HR280 ■ 24-30614-75/0	NC006 35x48x7mm, MVQ (50-319161-00) NB700 ■ 31x50x8mm, FPM (50-306551-50) NB806 ■ 90x104x11mm, FPM (50-306552-00)	







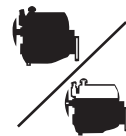

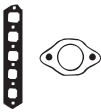

DAEWOO

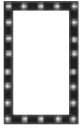

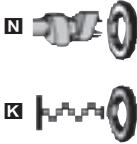
KW/PS



Tico 0.8L				02/95 → 12/00	41	AD5690 (Fibre) <i>(30-029654-00)</i>	CD5690 <i>(21-29654-20/0)</i>	ED5690 FD5690
F8C	796	3	68.50	SOHC	35/47			
F8CV	796	3	68.50		38/52			

								 AD5690
	HBS377  (22-77004B) M10x1.25x97mm (x10)	JD5740  (50-029661-00) JE5034  (31-029655-00)	JM5263 (50-029656-00) (Rubber)		HR5075  (24-31945-40/0)			



CC



9



CC



9

12R	Diesel	1588	4	80.50	61
1KR-FE	Petrol	998	3	71.00	26
1KR-FE	Petrol	998	3	71.00	54
3A-C	Petrol	1453	4	77.50	16
3A-U	Petrol	1453	4	77.50	17
3Y	Petrol	1998	4	86.00	33
3Y	Petrol	1998	4	86.00	48
4A	Petrol	1587	4	81.00	18
4K	Petrol	1290	4	75.00	15
AB 30	Petrol	548	2	71.60	21
AB 30	Petrol	548	2	71.60	37
AD	Petrol	617	2	76.00	29
AD 10	Petrol	617	2	76.00	22
CB	Petrol	993	3	76.00	39
CB	Petrol	993	3	76.00	59
CB 20	Petrol	993	3	76.00	9
CB 60	Petrol	993	3	76.00	8
CB 61	Petrol	993	3	76.00	8
CD	Petrol	843	3	70.00	38
CD	Petrol	843	3	70.00	58
CL	Diesel	993	3	76.00	7
CL 60	Diesel	993	3	76.00	6
CL 61	Diesel	993	3	76.00	7
CLT	Diesel	993	3	76.00	7
DL	Diesel	2765	4	92.00	49
DL	Diesel	2765	4	92.00	63
DL 51	Diesel	2746	4	92.00	50
DL 52	Diesel	2765	4	92.00	50
DLT	Diesel	2765	4	92.00	34
DLT	Diesel	2765	4	92.00	51
ED 10	Petrol	847	3	66.60	24
ED 10	Petrol	847	3	66.60	30
ED 10	Petrol	847	3	66.60	43
ED 10 K	Petrol	847	3	66.60	25
ED 20	Petrol	847	3	66.60	25
ED 20	Petrol	847	3	66.60	45
EF-EL	Petrol	847	3	66.60	25
EF-GL	Petrol	659	3	68.00	44
EF-JL	Petrol	659	3	68.00	23
EF-JL	Petrol	659	3	68.00	41
EJDE	Petrol	989	3	72.00	27
EJDE	Petrol	989	3	72.00	28
EJDE	Petrol	989	3	72.00	46
EJDE	Petrol	989	3	72.00	53
EJDE	Petrol	989	3	72.00	56
EJDE	Petrol	989	3	72.00	64
EJ-VE	Petrol	989	3	72.00	27
EJ-VE	Petrol	989	3	72.00	5
EJ-VE	Petrol	989	3	72.00	55
EJ-VE	Petrol	989	3	72.00	66
HC	Petrol	1296	4	76.00	12
HCE	Petrol	1296	4	76.00	11
HCE	Petrol	1296	4	76.00	40
HD	Petrol	1589	4	78.00	2
HD	Petrol	1589	4	78.00	47
HD	Petrol	1589	4	78.00	60
HD-E	Petrol	1590	4	76.00	1
HD-E	Petrol	1590	4	76.00	14
HD-E	Petrol	1590	4	76.00	3
HD-E	Petrol	1590	4	76.00	32
HDEP	Petrol	1590	4	76.00	36
HEE	Petrol	1499	4	76.00	13
HEEG	Petrol	1499	4	76.00	13
HEEG	Petrol	1499	4	76.00	35
K3-VE	Petrol	1298	4	72.00	19
K3-VE	Petrol	1298	4	72.00	20
K3-VE	Petrol	1298	4	72.00	31
K3-VE	Petrol	1298	4	72.00	4
K3-VE	Petrol	1298	4	72.00	42

K3-VE	Petrol	1298	4	72.00	52
K3-VE	Petrol	1298	4	72.00	57
K3-VE	Petrol	1298	4	72.00	62
K3-VE	Petrol	1298	4	72.00	65
K3-VE	Petrol	1298	4	72.00	67
K3-VE2	Petrol	1298	4	72.00	57
K3-VET	Petrol	1298	4	72.00	68



KW/PS

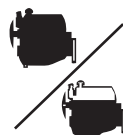

Applause 1.6L 16V 06/89 → 07/97 1						BR880 (Graphite)	DR880	GR880
Applause 1.6L 16V 4WD 06/89 → 07/97								
HD-E	1590	4	76.00	Injection, SOHC	70-77/ 95-105			
Applause 1.6L 16V 06/89 → 07/97 2						BR880 (Graphite)	DR880 →12/89 DR881 01/90 → 12/90 DR883 01/91 →	GR881 01/90 → 12/90 GR883 01/91 →
HD	1589	4	78.00	DOHC	66-67/ 90-91			
Ascend 1.6L 06/94 → 03/96 3						BR880 (Graphite)	DR880	GR880
HD-E	1590	4	76.00	Injection, SOHC	70-77/ 95-105			
Bego 1.3L DVVT 11/05 → 4						AG9830 (MLS)	CG9830	
Bego 1.3L DVVT 4x4 11/05 →								
K3-VE	1298	4	72.00		63-64/ 86-87			
Charade 1.0L 03/03 → 5						AG5920 (MLS)	CG5290	FG5290
EJ-VE	989	3	72.00		43/58			
Charade 1.0L TD Diesel 02/85 → 03/87 6						BR670 (Graphite)	DR670	GR670
CL 60	993	3	76.00	Indirect Injection	34/46			
Charade 1.0L TD Diesel 03/87 → 12/92 7						BR670 (Graphite)	DR670	GR670
Charade 1000 Diesel 01/87 →								
CL	993	3	76.00		27-35/ 37-48			
CL 61	993	3	76.00	Indirect Injection	35/47			
CLT	993	3	76.00	Turbo				
Charade 1.0L Turbo 10/83 → 10/90 8						BS430 (Graphite)	DS432	GS438
CB 60	993	3	76.00		50/68			
CB 61	993	3	76.00	SOHC	50/68			
Charade 1000 01/78 → 9						BS430 (Graphite)	DS430	GS430
CB 20	993	3	76.00	SOHC	37-38/ 50-52			
Charade 1000 10/87 → 10						BR760 (Graphite)	DR760	GR760
CBT				DOHC				
Charade 1.3L 11/90 → 02/93 11						BR880 (Graphite)	DR880	GR880
Charade 1.3L i 06/88 → 12/92								
Charade 1.3L i 4WD 06/88 → 01/93								
HCE	1296	4	76.00	Injection	62-66/ 84-90			
Charade 1.3L 09/96 → 11/99 12						BR880 (Graphite)	DR882 1990 →	GR882 1990 →
Charade 1.3L 16V 01/93 → 11/99								
HC	1296	4	76.00	Injection, SOHC	44-62/ 60-84			
Charade 1.5L 16V 08/94 → 11/99 13						BR880 (Graphite)		
Charade 1.5L HG Mk IV 06/94 → 03/96								
HEE	1499	4	76.00	SOHC	66/89			
HEEG	1499	4	76.00	Injection, SOHC	66/89			
Charade 1.6L GS 03/93 → 03/96 14						BR880 (Graphite)	DR880	GR880
Charade 1.6L GTi 03/93 → 11/99								
HD-E	1590	4	76.00	Injection, SOHC	70-77/ 95-105			
Charmant 1.3L 11/81 → 07/87 15						BD950 (Graphite) (30-028070-00)	DD952 ■ DD955 1982 →	GD952 GD955 01/82 →
4K	1290	4	75.00	OHV	48/65			

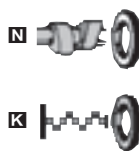
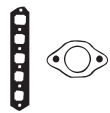

BD950



BR670



BR760



BR880



BS430



JB910



JC088



JC938

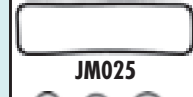

JM025



JN415



JN700



JN718



JJ094



JJ126

JD5744 ■
JD5745 ■

PA952 (x16)

■ NJ347 38x50x8mm, NBR
■ NK209 ■ 33.8x48x6mm, MVQ
■ NJ360 ■ 80x100x8.5mm, MVQ

JD5744 ■
JD5745 ■
⊙ JE146
→12/89

JN700
10/88 →

JJ435
1990 →

PA952 (x16)

■ NJ347 38x50x8mm, NBR
■ NK209 ■ 33.8x48x6mm, MVQ
■ NJ360 ■ 80x100x8.5mm, MVQ

JD5744 ■
JD5745 ■

PA952 (x16)

■ NJ347 38x50x8mm, NBR
■ NK209 ■ 33.8x48x6mm, MVQ
■ NJ360 ■ 80x100x8.5mm, MVQ

⊙ JE146

PA387 (x6)

■ NJ270 28x42x8mm, NBR
■ NJ324 ■ 34x48x7mm, ACM

⊙ JE146

JN415

JJ126

PA387 (x6)

■ NJ268 32x48x7mm, NBR
■ NJ324 ■ 34x48x7mm, ACM
■ NJ269 ■ 58x74x10mm, ACM

JC938 ■
JC088 ■
⊙ JE146

JN415

JJ126

PA387 (x6)

■ NJ268 32x48x7mm, NBR
■ NJ324 ■ 34x48x7mm, ACM
■ NJ269 ■ 58x74x10mm, ACM

⊙ JE146

JN718

PA971 (x6)

■ NJ268 32x48x7mm, NBR
■ NJ001 ■ 70x92x8.5mm, MVQ

JD5744 ■
JD5745 ■

■ NK209 ■ 33.8x48x6mm, MVQ

JD5744 ■
JD5745 ■
⊙ JE146

JN700

PA952 (x16)

■ NK209 ■ 33.8x48x6mm, MVQ
■ NJ360 ■ 80x100x8.5mm, MVQ

■ NJ347 38x50x8mm, NBR
■ NK209 ■ 33.8x48x6mm, MVQ
■ NJ360 ■ 80x100x8.5mm, MVQ

JD5744 ■
JD5745 ■

PA952 (x16)

■ NJ347 38x50x8mm, NBR
■ NK209 ■ 33.8x48x6mm, MVQ
■ NJ360 ■ 80x100x8.5mm, MVQ

JB910 (x2)
⊙ JE013 [149]
⊙ JE050
⊙ JE619
01/79 → 12/82
⊙ JE015 [149]
1982 →

JM025

JJ094

KJ466 (x8)

■ NJ102 ■ 38.5x58x11mm, NBR
■ NJ001 ■ 70x92x8.5mm, MVQ



KW/PS

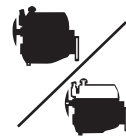

Model	CC	Cyl	Stroke	SOHC	Injection	Year Range	Power (KW/PS)	Head	Block	Accessories
Charmant 1500 3A-C	1453	4	77.50	SOHC		01/81 → 08/88	16 50/52/ 68/71	BG670 (Fibre) BL340 (Graphite)	DL340 (21-28079-20/0) 01/83 → 09/84	GL340
Charmant 1500 3A-U	1453	4	77.50	SOHC		01/81 → 09/90	17 59/80	BG670 (Fibre) BL340 (Graphite) 01/83 → 09/84	DL340 (21-28079-20/0) 01/83 → 09/84 DL341 10/84 →	GL340 01/83 → 09/84 GL341 10/84 →
Charmant 1.6L 4A	1587	4	81.00	SOHC		08/83 → 07/87	18 57-61/ 78-83	BL740 (Graphite)		GL741
Coo 1.3L K3-VE	1298	4	72.00			10/06 →	19 63-64/ 86-87	AG9830 (MLS)	CG9830	
Copen 1.3L K3-VE	1298	4	72.00			03/06 →	20 63-64/ 86-87	AG9830 (MLS)	CG9830	
Cuore 0.5L AB 30	548	2	71.60			10/80 → 09/85	21 20/27	BJ630 (Graphite)	DN250	
Cuore 0.6L AD 10	617	2	76.00	SOHC		08/82 → 09/85	22 22/30	BM450 (Graphite)	DM450	
Cuore 0.7L Mk III Cuore 0.7L Mk VII EF-JL	659	3	68.00	Injection, SOHC		08/90 → 09/94 03/03 →	23	AG7970	CG7970	
Cuore 0.8L Cuore 0.8L 4WD ED 10	847	3	66.60	SOHC		09/85 → 12/90 09/86 → 10/88	24 29-32/ 39-44	BR140 (Graphite)	DR140	GR140
Cuore 0.8L EF-EL ED 10 K ED 20	847	3	66.60	Injection, SOHC SOHC SOHC		10/90 → 10/98	25 29-31/ 40-42 30/41 32/43	BR140 (Graphite)	DR140	
Cuore 1.0L Mk VIII 1KR-FE	998	3	71.00	Injection, DOHC		04/07 →	26 50/68	AG9310 (MLS)	CG9310	EG9310
Cuore 1.0L DVVT Mk VI Cuore 1.0L Mk VI EJDE EJ-VE	989	3	72.00	Injection, DOHC		10/00 → 02/03 11/98 → 09/00	27 41/55 43/58	AG5920 (MLS)	CG5290	FG5290
Cuore 1.0L i EJDE	989	3	72.00	Injection, DOHC		10/98 → 05/03	28 41/55	AG5920 (MLS)	CG5290	FG5290 → 12/02 FG5920
Domino 600 (L60) AD	617	2	76.00			05/82 →	29	BM450 (Graphite)	DM450	
Domino 0.9 (L80) ED 10	847	3	66.60	SOHC		01/86 →	30 29-32/ 39-44	BR140 (Graphite)	DR140	GR140

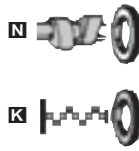
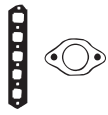

BG670



BJ630



BL340



BL740



BM450



BR140



JC116



JN356



JN663

	JC116 ⊗ JE012 [149] ⊗ JE013 [149] ⊗ JE015 [149]	JN356		KJ722 (x8)	<input checked="" type="checkbox"/> NJ353 35x49x6mm, NBR <input checked="" type="checkbox"/> NJ349 32.5x46x6mm, NBR <input checked="" type="checkbox"/> NJ001 70x92x8.5mm, MVQ	
	JC116 ⊗ JE013 [149] →12/82 ⊗ JE015 [149] ⊗ JE012 [149] 01/83→	JN356		KJ722 (x8)	<input checked="" type="checkbox"/> NJ353 35x49x6mm, NBR <input checked="" type="checkbox"/> NJ349 32.5x46x6mm, NBR <input checked="" type="checkbox"/> NJ001 70x92x8.5mm, MVQ	
				PA387 (x4)	<input checked="" type="checkbox"/> NJ268 32x48x7mm, NBR <input checked="" type="checkbox"/> NJ268 32x48x7mm, NBR <input checked="" type="checkbox"/> NJ269 58x74x10mm, ACM	
		JN663		PA889 (x6)	<input checked="" type="checkbox"/> NK138 38x52x11mm, ACM <input checked="" type="checkbox"/> NJ269 58x74x10mm, ACM	
		JN663				
	JD5845 <input checked="" type="checkbox"/> (NBR) JD5846 <input checked="" type="checkbox"/> (MLS) JD5863 <input checked="" type="checkbox"/> (Steel Elastomer)	JM7042 (ACM)			<input checked="" type="checkbox"/> NA5260 38x50x6mm	
		JM5301 (ACM) →12/02 EJ-DE / EJ-VE				
				PA387 (x4)	<input checked="" type="checkbox"/> NJ268 32x48x7mm, NBR <input checked="" type="checkbox"/> NJ268 32x48x7mm, NBR <input checked="" type="checkbox"/> NJ269 58x74x10mm, ACM	
		JN663		PA889 (x6)	<input checked="" type="checkbox"/> NK138 38x52x11mm, ACM <input checked="" type="checkbox"/> NJ269 58x74x10mm, ACM	



KW/PS

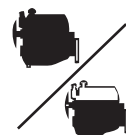

Extol 1.3L 07/00 → 31						AG9830 (MLS)	CG9830	
Extol 1.3L 4x4 07/00 → 09/03								
Extol 1.3L L 10/03 →								
K3-VE	1298	4	72.00		63-64/ 86-87			
Feroza 1.6L i 16V 10/88 → 32						BR880 (Graphite)		GR880
HD-E	1590	4	76.00	Injection, SOHC	70-77/ 95-105			
Fourtrak 2000 4WD 01/85 → 33						BL820 (Graphite) →08/85 BN640 (Graphite) 09/85 →	DL820 ■ →08/85 DN640 09/85 →	GL820 →08/85 GN640 09/85 →
3Y	1998	4	86.00	Carburettor, OHV	65/88			
Fourtrak 2.8L TD Diesel 04/84 → 34						BP560 (Fibre)	DP560 ■ →03/87 DP561 04/87 → 12/89 DP564 01/90 →	GP560 →03/87 GP561 04/87 → 12/89 GP564 12/90 →
DLT	2765	4	92.00	Direct Injection, Turbo	65-71/ 88-97			
Gran Move 1.5L 16V 10/96 → 07/98 35						BR880 (Graphite)		
HEEG	1499	4	76.00	Injection, SOHC	66/89			
Gran Move 1.6L 16V 05/98 → 36						BR880 (Graphite) →05/00		
Gran Move 1.6L GX 06/98 → 07/02								
HDEP	1590	4	76.00	Injection, SOHC	67/91			
Hijet Van 0.5L 10/94 → 12/95 37						BJ630 (Graphite)	DN250	
AB 30	548	2	71.60		20/27			
Hijet 0.8L 06/86 → 10/90 38						BS090 (Graphite)	DE865	
Hijet Van 0.8L 06/86 → 12/89								
CD	843	3	70.00		29/39			
Hijet 1.0L 06/86 → 12/89 39							DS431	
Hijet Van 1.0L 06/86 → 12/89								
CB	993	3	76.00	SOHC	33/45			
Hijet 1.3L 06/98 → 10/99 40								GR880
HCE	1296	4	76.00	Injection	62-66/ 84-90			
Leeza Coupe 0.7L Turbo 08/90 → 08/94 41						AG7970	CG7970	
EF-JL	659	3	68.00	Injection, SOHC				
Materia 1.3L 10/06 → 42						AG9830 (MLS)	CG9830	
K3-VE	1298	4	72.00		63-64/ 86-87			
Mira 0.9L 01/86 → 43						BR140 (Graphite)	DR140	GR140
ED 10	847	3	66.60	SOHC	29-32/ 39-44			
Move 0.7L 06/94 → 08/98 44						AG7970	CG7970	
EF-GL	659	3	68.00	Injection, DOHC				
Move 0.8L 10/96 → 45						BR140 (Graphite)	DR140	
ED 20	847	3	66.60	SOHC	32/43			
Move 1.0L i 10/98 → 46						AG5920 (MLS) →09/02	CG5290 →12/02	FG5290 →12/02
EJDE	989	3	72.00	Injection, DOHC	41/55			

HBS312 ⊕ [22-71017B] M9x1.25x84mm (x10)	JD5836 ■ JD5837 ■ (MLS) 0,5mm	JM5149 (Rubber)					BJ630 BL820 BN640 BP560 BR140 BR880 BS090 JC658 JN405 JN415 JN551 JN663 JJ126
	JD5744 ■ JD5745 ■			PA952 (x16)	<input checked="" type="checkbox"/> NJ347 38x50x8mm, NBR <input checked="" type="checkbox"/> NK209 ■ 33.8x48x6mm, MVQ <input checked="" type="checkbox"/> NJ306 ■ 130x161x14mm, MVQ		
	JC658 ■ 08/85→ JC615 ■ 08/85→ <input checked="" type="checkbox"/> JE012 (x2) [149] <input checked="" type="checkbox"/> JE124 [149]	JN551		PA385 (x8)	<input checked="" type="checkbox"/> NJ344 ■ 42x60x7mm, NBR <input checked="" type="checkbox"/> NJ360 ■ 80x100x8.5mm, MVQ		
		JN405 →03/87		PA260 (x8)	<input checked="" type="checkbox"/> NJ098 ■ 95x110x11mm, MVQ →01/90 <input checked="" type="checkbox"/> NJ276 ■ 45x62x9mm, NBR 04/84→03/87		
					<input checked="" type="checkbox"/> NJ347 38x50x8mm, NBR <input checked="" type="checkbox"/> NK209 ■ 33.8x48x6mm, MVQ <input checked="" type="checkbox"/> NJ360 ■ 80x100x8.5mm, MVQ		
					<input checked="" type="checkbox"/> NK209 ■ 33.8x48x6mm, MVQ		
		JN415	JJ126	PA387 (x6)	<input checked="" type="checkbox"/> NJ268 32x48x7mm, NBR <input checked="" type="checkbox"/> NJ324 ■ 34x48x7mm, ACM <input checked="" type="checkbox"/> NJ269 ■ 58x74x10mm, ACM		
	JD5744 ■ JD5745 ■				<input checked="" type="checkbox"/> NK209 ■ 33.8x48x6mm, MVQ		
HBS312 ⊕ [22-71017B] M9x1.25x84mm (x10)	JD5836 ■ JD5837 ■ (MLS) 0,5mm	JM5149 (Rubber)					
		JN663		PA889 (x6)	<input checked="" type="checkbox"/> NK138 ■ 38x52x11mm, ACM <input checked="" type="checkbox"/> NJ269 ■ 58x74x10mm, ACM		
		JN663					
		JM5301 (ACM) →09/02					



KW/PS

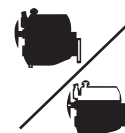

Rocky 1600 (USA)					06/89 →	47	BR880 (Graphite)	DR880	GR881
HD	1589	4	78.00			66-67/ 90-91	12/91 →	→12/89 DR881 01/90 →12/90 DR883 01/91 →	01/90 →12/90 GR883 01/91 →
Rocky 2.0L					02/85 →04/93	48	BL820 (Graphite)	DL820	GL820
3Y	1998	4	86.00	Carburettor, OHV		65/88	→08/85 BN640 (Graphite) 09/85 →	→08/85 DN640 09/85 →	→08/85 GN640 09/85 →
Rocky 2.8L D Diesel					02/85 →	49	BM900 (Graphite)	DM900	GM901
DL	2765	4	92.00	Indirect Injection		51-54/ 69-73	04/84 →12/90 BP560 (Fibre) 01/90 →	10/82 →07/83 DM901 04/84 →07/84 DM902 08/87 →12/90 DP565 01/90 →	04/84 →07/87 GM902 08/87 →12/90 GP565 01/90 →
Rocky 2.8L TD Diesel					12/87 →04/93	50	BM900 (Graphite)	DP564	
DL 51	2746	4	92.00	Indirect Injection		67/91			
DL 52	2765	4	92.00	OHV		72-75/ 98-102			
Rocky 2800 Turbo Diesel					04/84 →	51	BP560 (Fibre)	DP560	GP560
DLT	2765	4	92.00	Direct Injection, Turbo		65-71/ 88-97	12/90 →	→03/87 DP561 04/87 →12/89 DP564 01/90 →	→03/87 GP561 04/87 →12/89 GP564 12/90 →
Rush 1.3L					11/05 →	52	AG9830 (MLS)	CG9830	
K3-VE	1298	4	72.00			63-64/ 86-87			
Sirion 1.0L					04/98 →10/00	53	AG5920 (MLS)	CG5290	FG5920
Sirion 1.0L i					04/98 →09/00				
EJDE	989	3	72.00	Injection, DOHC		41/55			
Sirion 1.0L					01/05 →	54	AG9310 (MLS)	CG9310	EG9310
Sirion 1.0L DVVT 4WD					04/05 →				
1KR-FE	998	3	71.00	Injection, DOHC		50/68			
Sirion 1.0L i					09/00 →01/05	55	AG5920 (MLS)	CG5920	FG5920
Sirion 1.0L i 4WD					09/00 →01/05		→12/02		
EJ-VE	989	3	72.00			43/58			
Sirion 1.0L i 4WD					04/99 →09/00	56	AG5920 (MLS)		FG5290
EJDE	989	3	72.00	Injection, DOHC		41/55			

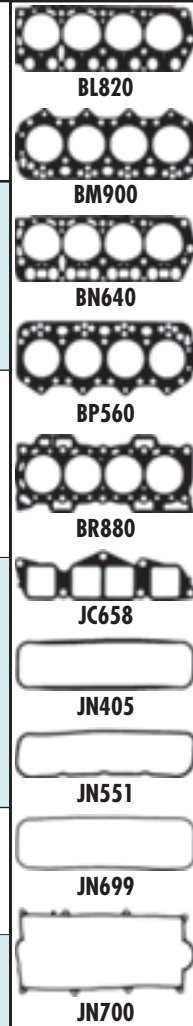
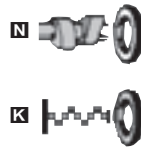
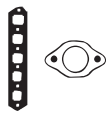

	JD5744 ■ JD5745 ■ JE146 →12/89	JN700 10/88 →	JJ435 1990 →	PA952 (x16)	NJ347 38x50x8mm, NBR NK209 33.8x48x6mm, MVQ NJ360 80x100x8.5mm, MVQ		
	JC658 ■ 08/85 → JC615 ■ 08/85 → JE012 (x2) [149] JE124 [149]	JN551		PA385 (x8)	NJ344 42x60x7mm, NBR NJ360 80x100x8.5mm, MVQ		
	JD5743 ■ JD5741 ■ JD5742 ■	JN699 →12/90		PA260 (x8) →12/87	NJ276 45x62x9mm, NBR →12/90 NJ098 95x110x11mm, MVQ →12/90		
	JD5743 ■ JD5741 ■ JD5742 ■	JN636					
		JN405 →03/87		PA260 (x8)	NJ276 45x62x9mm, NBR NJ098 95x110x11mm, MVQ →01/90		
HBS312 © [22-71017B] M9x1.25x84mm (x10)	JD5836 ■ JD5837 ■ (MLS) 0,5mm	JM5149 (Rubber)					
	JD5845 ■ (NBR) JD5846 ■ (MLS) JD5863 ■ (Steel Elastomer)	JM7042 (ACM)			NA5260 38x50x6mm		
		JM5149 (Rubber) JM5301 (ACM) EJ-VE					



KW/PS

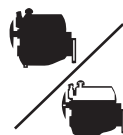

Sirion 1.3L 01/05 → 57					AG9830 (MLS)	CG9830		
Sirion 1.3L 4WD 04/05 →								
Sirion 1.3L DVVT 16V 02/01 → 04/05								
Sirion 1.3L DVVT CX 16V 4x4 02/01 → 10/02								
Sirion 1.3L Sport 08/00 → 01/05								
Sirion 1.3L Sport 4WD 08/00 → 01/05								
K3-VE	1298	4	72.00		63-64/ 86-87			
K3-VE2	1298	4	72.00		75/102			
Sparcar 0.8L 09/83 → 05/86 58					BS090 (Graphite)			
Sparcar Van 0.8L 09/83 → 05/86								
CD	843	3	70.00		29/39			
Sparcar 1.0L 09/83 → 05/86 59						DS431		
Sparcar Van 1.0L 09/83 → 05/86								
CB	993	3	76.00	SOHC	33/45			
Sportrak 1600 (F300) 06/89 → 60					BR880 (Graphite)		DR881 DR883	
HD	1589	4	78.00					
Taft 1.6L Diesel 09/76 → 02/85 61					AJ910 (Graphite)		CJ911 ■	
12R	1588	4	80.50					
Terios 1.3L 09/01 → 10/05 62					AG9830 (MLS)	CG9830		
Terios 1.3L 4WD 10/00 → 10/05								
Terios 1.3L DVVT 4x4 11/05 →								
Terios 1.3L DVVT FWD 10/02 → 10/05								
K3-VE	1298	4	72.00		63-64/ 86-87			
Wildcat/Rocky 2.8L D Diesel 02/85 → 03/87 63					BM900 (Graphite)		DM901 ■	
DL	2765	4	92.00	Indirect Injection				
Xenia 1.0L 01/02 → 64					AG5920 (MLS)			
EJDE	989	3	72.00	Injection, DOHC				
Xenia 1.3L 01/02 → 65					AG9830 (MLS)		CG9830	
Xenia 1.3L DVVT 05/07 →								
K3-VE	1298	4	72.00		63-64/ 86-87			
YRV 1.0L 02/01 → 66					AG5920 (MLS)		CG5290	
EJ-VE	989	3	72.00					
YRV 1.3L 02/01 → 67					AG9830 (MLS)		CG9830	
YRV 1.3L 4WD 02/01 →								
K3-VE	1298	4	72.00		63-64/ 86-87			
YRV 1.3L GT ti 07/02 → 68					AG9830 (MLS)		CG9830	
K3-VET	1298	4	72.00					

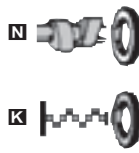
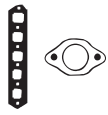

AJ910



BM900



BR880



BS090



JN415



JN699



JN700



JH021



JJ126

HBS312⊙
(22-71017B)
M9x1.25x84mm (x10)

JD5836■
JD5837■
(MLS)
0,5mm

JM5149
(Rubber)

JN415

JJ126

PA387 (x6)

☒ NJ268 32x48x7mm, NBR
☒ NJ324■ 34x48x7mm, ACM
☒ NJ269■ 58x74x10mm, ACM

⊙JE146
→12/89

JN700
10/88 →

JJ435
01/90 →

PA952 (x16)

☒ NJ347 38x50x8mm, NBR
☒ NK209■ 33.8x48x6mm, MVQ
☒ NJ360■ 80x100x8.5mm, MVQ

JH021
01/71 →12/80

PA021 (x8)
01/77 →

☒ KV412
☒ NJ102■ 38.5x58x11mm, NBR

HBS312⊙
(22-71017B)
M9x1.25x84mm (x10)

JD5836■
JD5837■
(MLS)
0,5mm

JM5149
(Rubber)

JN699

PA260 (x8)

☒ NJ276■ 45x62x9mm, NBR
☒ NJ098■ 95x110x11mm, MVQ

HBS312⊙
(22-71017B)
M9x1.25x84mm (x10)

JD5836■
JD5837■
(MLS)
0,5mm

JM5149
(Rubber)

JM5301
(ACM)
EJ-VE

HBS312⊙
(22-71017B)
M9x1.25x84mm (x10)









JD5836■
JD5837■
(MLS)
0,5mm









JM5149
(Rubber)









HBS312⊙
(22-71017B)
M9x1.25x84mm (x10)









JD5836■

JM5149
(Rubber)

		CC			9			CC			9
100 GF 000	Petrol	903	4	65.00	198	146 A9.000	Petrol	1116	4	76.00	132
100 GF 000	Petrol	903	4	65.00	4	146 B.000	Diesel	1367	4	78.00	382
100 GF 000	Petrol	903	4	65.00	9	146 B1.000	Diesel	1301	4	76.10	374
100 GL.000	Petrol	903	4	65.00	129	146 B2.000	Diesel	1697	4	82.60	142
100 GL.000	Petrol	903	4	65.00	198	146 B2.000	Diesel	1697	4	82.60	385
100 GL.000	Petrol	903	4	65.00	4	146 B3.000	Diesel	1367	4	78.00	382
100 GL.048	Petrol	903	4	65.00	198	146 C1.000	Petrol	1372	4	80.50	313
100 GL.048	Petrol	903	4	65.00	4	146 C1.000	Petrol	1372	4	80.50	328
100 GL3.000	Petrol	903	4	65.00	198	146 C1.000	Petrol	1372	4	80.50	377
100 GL3.000	Petrol	903	4	65.00	199	146 C3.000	Petrol	1116	4	80.00	372
100 GL3.000	Petrol	903	4	65.00	4	146 C5.000	Petrol	1372	4	80.50	137
1170 A1.000	Petrol	899	4	65.00	48	146 C6.000	Petrol	1581	4	86.40	139
1170 A1.046	Petrol	899	4	65.00	200	146 D5.000	Petrol	1372	4	80.50	136
1170 A1.046	Petrol	899	4	65.00	279	146 D5.000	Petrol	1372	4	80.50	137
1170 A1.046	Petrol	899	4	65.00	48	146 D5.000	Petrol	1372	4	80.50	313
126 A1.000	Petrol	652	2	77.00	1	146 D5.000	Petrol	1372	4	80.50	328
126 A1.048	Petrol	652	2	77.00	1	146 D5.000	Petrol	1372	4	80.50	377
126 A2.000	Petrol	704	2	80.00	3	146 D6.000	Petrol	1585	4	86.40	139
126 A2.048	Petrol	704	2	80.00	3	146 D7.000	Diesel	1697	4	82.60	143
127 A.000	Petrol	903	4	65.00	131	146 D7.000	Diesel	1697	4	82.60	192
127 A.000	Petrol	903	4	65.00	198	146 D7.000	Diesel	1697	4	82.60	232
127 A.000	Petrol	903	4	65.00	4	146 D7.000	Diesel	1697	4	82.60	307
127 A.000	Petrol	903	4	65.00	5	146C.7000	Petrol	994	4	76.00	364
127 A5.000	Diesel	1301	4	76.00	127	147A5.000	Petrol	1048	4	76.00	130
127 A5.000	Diesel	1301	4	76.00	134	149 A1.000	Diesel	1929	4	82.60	246
127 A5.000	Diesel	1301	4	76.00	211	149 A3.000	Petrol	1302	4	86.40	238
127 A5.000	Diesel	1301	4	76.00	363	149 A3.000	Petrol	1302	4	86.40	251
127 A5.000	Diesel	1301	4	76.00	374	149 A4.000	Petrol	1585	4	84.00	243
127 A5.000	Diesel	1301	4	76.00	6	149 A5.000	Petrol	1498	4	86.40	239
132 D.000	Petrol	1585	4	84.00	12	149 A5.000	Petrol	1498	4	86.40	256
138 A1.000	Petrol	1302	4	86.40	250	149 A7.000	Petrol	1302	4	86.40	238
138 A3.000	Petrol	1302	4	86.40	252	149 A7.000	Petrol	1302	4	86.40	251
138 A4.000	Petrol	1498	4	86.40	255	149 A7.000	Petrol	1302	4	86.40	373
138 A5.000	Diesel	1714	4	83.00	263	149 B1.000	Diesel	1929	4	82.60	310
138 AR.000	Petrol	1585	4	84.00	258	149 B1.000	Diesel	1929	4	82.60	90
138 AR.000	Petrol	1585	4	84.00	259	149 B3.000	Diesel	1697	4	82.60	126
138 B.000	Petrol	1116	4	80.00	303	149 B3.000	Diesel	1697	4	82.60	141
138 B.000	Petrol	1116	4	80.00	369	149 B3.000	Diesel	1697	4	82.60	244
138 B2.000	Petrol	1302	4	86.40	238	149 B3.000	Diesel	1697	4	82.60	261
138 B2.000	Petrol	1302	4	86.40	251	149 B3.000	Diesel	1697	4	82.60	385
138 B2.000	Petrol	1302	4	86.40	373	149 B4.000	Diesel	1697	4	82.60	334
138 B3.000	Petrol	1498	4	86.40	240	149 B5.046	Diesel	1929	4	82.60	386
138 B3.000	Petrol	1498	4	86.40	254	149 C1.000	Petrol	1498	4	86.40	138
138 B6.000	Diesel	1714	4	83.00	245	149 C1.000	Petrol	1498	4	86.40	242
138 B6.000	Diesel	1714	4	83.00	262	149 C1.000	Petrol	1498	4	86.40	253
138 C.000	Diesel	1698	4	86.40	261	149 C1.000	Petrol	1498	4	86.40	257
138 C2.048	Petrol	1498	4	86.40	241	149 C1.000	Petrol	1498	4	86.40	383
138 C2.048	Petrol	1498	4	86.40	242	149 C2.046	Petrol	1585	4	84.00	333
138 C2.048	Petrol	1498	4	86.40	253	154 A1.000	Petrol	1995	4	84.00	61
138 C2.048	Petrol	1498	4	86.40	257	154 A2.000	Petrol	1995	4	84.00	65
138 C2.048	Petrol	1498	4	86.40	383	154 C3.000	Petrol	1995	4	84.00	63
141 A.000	Petrol	652	2	77.00	194	154 C3.046	Petrol	1995	4	84.00	325
141 A.000	Petrol	652	2	77.00	2	154 C3.046	Petrol	1995	4	84.00	64
141 B.000	Petrol	770	4	65.00	196	154 C4.046	Petrol	1995	4	84.00	66
141 C2.000	Petrol	999	4	70.00	203	154 C5.000	Petrol	1995	4	84.00	59
146 A.000	Petrol	903	4	65.00	199	154 C6.000	Diesel	1929	4	82.60	58
146 A.000	Petrol	903	4	65.00	362	154 D1.000	Diesel	1929	4	82.60	58
146 A.1000	Petrol	903	4	65.00	362	154 E1.000	Petrol	1995	4	84.00	60
146 A2.000	Petrol	1301	4	80.50	376	156 A2.048	Petrol	999	4	70.00	365
146 A2.146	Petrol	1301	4	80.50	375	156 A2.100	Petrol	999	4	70.00	202
146 A2.246	Petrol	1301	4	80.50	375	156 A2.100	Petrol	999	4	70.00	203
146 A4.044	Petrol	1116	4	80.00	367	156 A2.100	Petrol	999	4	70.00	365
146 A4.048	Petrol	1116	4	80.00	248	156 A2.246	Petrol	999	4	70.00	203
146 A4.048	Petrol	1116	4	80.00	371	156 A2.246	Petrol	999	4	70.00	366
146 A5.000	Petrol	1301	4	76.10	125	156 A2.246	Petrol	1108	4	70.00	206
146 A5.000	Petrol	1301	4	76.10	133	156 A3.100	Petrol	999	4	70.00	203
146 A6.000	Petrol	1116	4	76.00	124	156 A4.000	Petrol	770	4	65.00	197
146 A8.000	Petrol	1372	4	80.50	379	156 A4.048	Petrol	770	4	65.00	195
146 A8.046	Petrol	1372	4	80.50	380	156 A5.000	Diesel	1301	4	76.10	213

		CC			9			CC			9
156 C.046	Petrol	1108	4	70.00	206	176 B1.000	Petrol	1242	4	70.80	222
156 C.046	Petrol	1108	4	70.00	368	176 B2.000	Petrol	1108	4	70.00	207
159 A2.000	Petrol	1372	4	80.50	312	176 B2.000	Petrol	1108	4	70.00	208
159 A2.000	Petrol	1372	4	80.50	328	176 B2.000	Petrol	1108	4	70.00	216
159 A3.000	Petrol	1581	4	86.40	128	176 B2.000	Petrol	1108	4	70.00	217
159 A3.000	Petrol	1581	4	86.40	215	176 B2.000	Petrol	1108	4	70.00	280
159 A3.000	Petrol	1581	4	86.40	314	176 B2.000	Petrol	1108	4	70.00	281
159 A3.046	Petrol	1585	4	86.40	315	176 B2.000	Petrol	1108	4	70.00	49
159 A3.046	Petrol	1585	4	86.40	317	176 B3.000	Diesel	1697	4	82.60	231
159 A3.046	Petrol	1585	4	86.40	332	176 B4.000	Petrol	1242	4	70.80	185
159 A3.046	Petrol	1585	4	86.40	384	176 B4.000	Petrol	1242	4	70.80	222
159 A3.048	Petrol	1585	4	86.40	316	176 B6.000	Petrol	1372	4	80.50	228
159 A3.048	Petrol	1585	4	86.40	331	176 B7.000	Diesel	1697	4	82.60	192
159 A4.000	Petrol	1756	4	84.00	319	176 B7.000	Diesel	1697	4	82.60	232
159 A4.000	Petrol	1756	4	84.00	336	176 B7.000	Diesel	1697	4	82.60	307
159 A4.046	Petrol	1756	4	84.00	319	176 B9.000	Petrol	1242	4	70.80	219
159 A4.046	Petrol	1756	4	84.00	338	176 B9.000	Petrol	1242	4	70.80	224
159 A5.046	Petrol	1995	4	84.00	344	178 B2.000	Petrol	1372	4	80.50	189
159 A6.046	Petrol	1995	4	84.00	324	178 B2.000	Petrol	1372	4	80.50	285
159 A6.046	Petrol	1995	4	84.00	345	178 B3.000	Petrol	1581	4	86.40	191
159 B9.000	Petrol	1581	4	86.40	318	178 B3.000	Petrol	1581	4	86.40	287
160 A1.000	Petrol	1372	4	80.50	327	178 B5.000	Petrol	1242	4	70.80	187
160 A1.046	Petrol	1372	4	80.50	311	178 B5.000	Petrol	1242	4	70.80	283
160 A1.046	Petrol	1372	4	80.50	328	178 B5.000	Petrol	1242	4	70.80	304
160 A1.046	Petrol	1372	4	80.50	378	178 B7.045	Petrol	1242	4	70.80	183
160 A1.048	Petrol	1372	4	80.50	327	178 C4.066	Petrol	1242	4	70.80	183
160 A1.048	Petrol	1372	4	80.50	381	178 C4.066	Petrol	1242	4	70.80	284
160 A2.000	Petrol	1585	4	86.40	329	178B2.016	Petrol	1372	4	80.50	189
160 A3.000	Petrol	1108	4	70.00	326	178B2.016	Petrol	1372	4	80.50	285
160 A3.000	Petrol	1108	4	70.00	370	178E2.000	Petrol	1242	4	70.80	185
160 A5.000	Petrol	1756	4	84.00	339	178E2.000	Petrol	1242	4	70.80	186
160 A6.000	Diesel	1929	4	82.60	322	182 A1.000	Petrol	1998	5	82.00	168
160 A6.000	Diesel	1929	4	82.60	323	182 A1.000	Petrol	1998	5	82.00	42
160 A6.000	Diesel	1929	4	82.60	342	182 A1.000	Petrol	1998	5	82.00	53
160 A6.046	Diesel	1929	4	82.60	342	182 A2.000	Petrol	1747	4	82.00	162
160 A7.000	Diesel	1929	4	82.60	22	182 A2.000	Petrol	1747	4	82.00	163
160 A7.000	Diesel	1929	4	82.60	321	182 A2.000	Petrol	1747	4	82.00	20
160 A7.000	Diesel	1929	4	82.60	340	182 A2.000	Petrol	1747	4	82.00	21
160 A7.000	Diesel	1929	4	82.60	35	182 A2.000	Petrol	1747	4	82.00	33
160 A8.046	Petrol	1995	4	84.00	343	182 A2.000	Petrol	1747	4	82.00	34
160 B6.046	Diesel	1929	4	82.60	322	182 A3.000	Petrol	1371	4	82.00	158
160 B6.046	Diesel	1929	4	82.60	323	182 A3.000	Petrol	1371	4	82.00	18
160 B6.046	Diesel	1929	4	82.60	341	182 A3.000	Petrol	1371	4	82.00	29
160 D1.000	Diesel	1929	4	82.60	322	182 A4.000	Petrol	1581	4	86.40	161
160 D1.000	Diesel	1929	4	82.60	323	182 A4.000	Petrol	1581	4	86.40	175
160 D1.000	Diesel	1929	4	82.60	342	182 A4.000	Petrol	1581	4	86.40	19
169 A1.000	Diesel	1248	4	69.60	212	182 A4.000	Petrol	1581	4	86.40	32
169 A1.000	Diesel	1248	4	69.60	7	182 A5.000	Petrol	1371	4	82.00	158
169 A3.000	Petrol	1368	4	72.00	214	182 A5.000	Petrol	1371	4	82.00	18
169 A3.000	Petrol	1368	4	72.00	8	182 A5.000	Petrol	1371	4	82.00	29
169 B (XM7T)	Petrol	1783	4	84.00	87	182 A6.000	Petrol	1581	4	86.40	19
170 A.000	Petrol	704	2	80.00	46	182 A6.000	Petrol	1581	4	86.40	32
170 A1.000	Petrol	903	4	65.00	47	182 A7.000	Diesel	1910	4	82.00	166
170 A1.046	Petrol	903	4	65.00	47	182 A7.000	Diesel	1910	4	82.00	25
175 A1.000	Petrol	1995	4	84.00	51	182 A7.000	Diesel	1910	4	82.00	38
175 A3.000	Petrol	1998	5	82.00	54	182 A8.000	Diesel	1910	4	82.00	166
176 A3.000	Diesel	1697	4	82.60	192	182 A8.000	Diesel	1910	4	82.00	25
176 A3.000	Diesel	1697	4	82.60	232	182 A8.000	Diesel	1910	4	82.00	38
176 A3.000	Diesel	1697	4	82.60	307	182 B2.000	Petrol	1242	4	70.80	157
176 A4.000	Petrol	1372	4	80.50	228	182 B2.000	Petrol	1242	4	70.80	16
176 A5.000	Diesel	1697	4	82.60	192	182 B2.000	Petrol	1242	4	70.80	26
176 A5.000	Diesel	1697	4	82.60	232	182 B3.000	Petrol	1998	5	82.00	52
176 A5.000	Diesel	1697	4	82.60	307	182 B4.000	Diesel	1910	4	82.00	164
176 A6.000	Petrol	1108	4	70.00	217	182 B4.000	Diesel	1910	4	82.00	178
176 A7.000	Petrol	1242	4	70.80	221	182 B4.000	Diesel	1910	4	82.00	24
176 A7.000	Petrol	1242	4	70.80	225	182 B4.000	Diesel	1910	4	82.00	37
176 A8.000	Petrol	1242	4	70.80	185	182 B6.000	Petrol	1596	4	80.50	159
176 A8.000	Petrol	1242	4	70.80	223	182 B6.000	Petrol	1596	4	80.50	173
176 A9.000	Petrol	1581	4	86.40	229	182 B6.000	Petrol	1596	4	80.50	190

		CC			9			CC			9
182 B6.000	Petrol	1596	4	80.50	286	192 A4.000	Petrol	1747	4	82.00	230
182 B6.000	Petrol	1596	4	80.50	292	192 A4.000	Petrol	1747	4	82.00	293
182 B6.000	Petrol	1596	4	80.50	31	192 A5.000	Diesel	1910	4	82.00	298
182 B6.000	Petrol	1596	4	80.50	80	192 A8.000	Diesel	1910	4	82.00	294
182 B6.000	Petrol	1596	4	80.50	81	192 A8.000	Diesel	1910	4	82.00	39
182 B6.000	Gas	1596	4	80.50	174	192 B1.000	Diesel	1910	4	82.00	300
182 B6.000	Bi-Fuel	1596	4	80.50	174	192 B2.000	Petrol	1368	4	72.00	28
182 B6.000	Bi-Fuel	1596	4	80.50	81	192 B2.000	Petrol	1368	4	72.00	291
182 B7.000	Petrol	1998	5	82.00	169	192 B5.000	Diesel	1910	4	82.00	301
182 B7.000	Petrol	1998	5	82.00	41	192A9.000	Diesel	1910	4	82.00	294
182 B9.000	Diesel	1910	4	82.00	23	194A1.000	Petrol	2198	4	86.00	67
182 B9.000	Diesel	1910	4	82.00	36	198 A1.000	Petrol	1368	4	72.00	28
182 B9.000	Diesel	1910	4	82.00	84	198 A4.000	Petrol	1368	4	72.00	148
183 A1.000	Petrol	1747	4	82.00	15	198 A4.000	Petrol	1368	4	72.00	28
183 A1.000	Petrol	1747	4	82.00	162	199 A2.000	Diesel	1248	4	69.60	135
183 A1.000	Petrol	1747	4	82.00	21	199 A2.000	Diesel	1248	4	69.60	145
183 A1.000	Petrol	1747	4	82.00	233	199 A2.000	Diesel	1248	4	69.60	237
183 A1.000	Petrol	1747	4	82.00	33	199 A2.000	Diesel	1248	4	69.60	76
183 A1.000	Petrol	1747	4	82.00	50	199 A2.000	Diesel	1248	4	69.60	77
185 A2.000	Diesel	2387	5	82.00	171	199 A3.000	Diesel	1248	4	69.60	146
185 A3.000	Petrol	1581	4	86.40	160	199 A3.000	Diesel	1248	4	69.60	151
185 A3.000	Bi-Fuel	1581	4	86.40	161	199 A3.000	Diesel	1248	4	69.60	156
185 A6.000	Diesel	2387	5	82.00	170	199 A4.000	Petrol	1242	4	70.80	144
185 A8.000	Petrol	1998	5	82.00	167	220 A 2.000	Petrol	1581	4	86.40	140
186 A3.000	Gas	1581	4	86.40	177	220 A 2.000	Petrol	1581	4	86.40	265
186 A4.000	Bi-Fuel	1581	4	86.40	161	220 A 2.000	Petrol	1581	4	86.40	330
186 A4.000	Bi-Fuel	1581	4	86.40	176	223 A5.000	Petrol	1242	4	70.80	74
186 A6.000	Diesel	1910	4	82.00	165	223 A6.000	Diesel	1910	4	82.00	193
186 A6.000	Diesel	1910	4	82.00	179	223 A6.000	Diesel	1910	4	82.00	288
186 A8.000	Diesel	1910	4	82.00	180	223 A6.000	Diesel	1910	4	82.00	308
186A9.000	Diesel	1910	4	82.00	181	223 A6.000	Diesel	1910	4	82.00	82
186A9.000	Diesel	1910	4	82.00	83	223 A7.000	Diesel	1910	4	82.00	83
187 A1.000	Petrol	1108	4	70.00	205	223 A7.000	Diesel	1910	4	82.00	85
187 A1.000	Petrol	1108	4	70.00	207	223 A9.000	Diesel	1248	4	69.60	306
187 A1.000	Petrol	1108	4	70.00	281	223 A9.000	Diesel	1248	4	69.60	75
188 A2.000	Diesel	1910	4	82.00	235	223 B1.000	Diesel	1910	4	82.00	83
188 A2.000	Diesel	1910	4	82.00	309	223 B1.000	Diesel	1910	4	82.00	85
188 A3.000	Diesel	1910	4	82.00	234	223 B2.000	Diesel	1910	4	82.00	84
188 A4.000	Petrol	1242	4	70.80	182	230 A2.000	Diesel	1929	4	82.60	89
188 A4.000	Petrol	1242	4	70.80	183	230 A3.000	Diesel	1929	4	82.60	90
188 A4.000	Petrol	1242	4	70.80	209	230 A3.000	Diesel	1929	4	82.60	93
188 A4.000	Petrol	1242	4	70.80	210	230 A4.000	Diesel	1929	4	82.60	90
188 A4.000	Petrol	1242	4	70.80	220	230 A4.000	Diesel	1929	4	82.60	93
188 A4.000	Petrol	1242	4	70.80	284	280 A1.000	Diesel	1929	4	82.60	91
188 A4.000	Petrol	1242	4	70.80	305	350 A1.000	Petrol	1368	4	72.00	147
188 A4.000	Bi-Fuel	1242	4	70.80	220	350 A1.000	Petrol	1368	4	72.00	153
188 A5.000	Petrol	1242	4	70.80	150	350 A1.000	Petrol	1368	4	72.00	79
188 A5.000	Petrol	1242	4	70.80	17	4HW (DW12ATED4)	Diesel	2179	4	85.00	360
188 A5.000	Petrol	1242	4	70.80	184	6132 AZ 2.000	Petrol	1995	4		43
188 A5.000	Petrol	1242	4	70.80	218	8140.27	Diesel	2500	4	93.00	111
188 A5.000	Petrol	1242	4	70.80	27	8140.27	Diesel	2500	4	93.00	113
188 A5.000	Petrol	1242	4	70.80	289	8140.43	Diesel	2800	4	94.40	121
188 A6.000	Petrol	1747	4	82.00	14	8140.43	Diesel	2800	4	94.40	122
188 A6.000	Petrol	1747	4	82.00	15	8140.43	Diesel	2800	4	94.40	123
188 A6.000	Petrol	1747	4	82.00	230	8140.43N	Diesel	2798	4	94.40	119
188 A6.000	Petrol	1747	4	82.00	233	8140.43S	Diesel	2800	4	94.40	118
188 A7.000	Diesel	1910	4	82.00	235	8140.47	Diesel	2499	4	93.00	114
188 A9.000	Diesel	1248	4	69.60	152	8140.47R	Diesel	2499	4	93.00	115
188 A9.000	Diesel	1248	4	69.60	188	8140.63	Diesel	2798	4	94.40	116
188 A9.000	Diesel	1248	4	69.60	212	8140.63	Diesel	2798	4	94.40	117
188 A9.000	Diesel	1248	4	69.60	226	8140.63	Diesel	2798	4	94.40	120
188 A9.000	Diesel	1248	4	69.60	78	8140.67	Diesel	2500	4	93.00	109
188 B2.000	Diesel	1910	4	82.00	155	8140.67	Diesel	2500	4	93.00	110
188 B2.000	Diesel	1910	4	82.00	236	8140.67.X230	Diesel	2499	4	93.00	108
192 A1.000	Diesel	1910	4	82.00	296	8142.61	Diesel	2445	4	93.00	104
192 A1.000	Diesel	1910	4	82.00	297	8144.21	Diesel	2445	4	93.00	105
192 A2.000	Petrol	2446	5	83.00	302	8144.21	Diesel	2445	4	93.00	112
192 A3.000	Diesel	1910	4	82.00	296	8144.21.220	Diesel	2445	4	93.00	106
192 A4.000	Petrol	1747	4	82.00	14	8144.61	Diesel	2445	4	93.00	102

		CC			9			CC			9
8144.67	Diesel	2500	4	93.00	107	RFL (XU10)	Petrol	1998	4	86.00	97
8144.67	Diesel	2500	4	93.00	110	RFN(EW10J4)	Petrol	1997	4	85.00	350
8144.67	Diesel	2500	4	93.00	70	RFU (XU10 J2C)	Petrol	1998	4	86.00	351
8144.91	Diesel	2445	4	93.00	69	RGX	Petrol	1998	4	86.00	358
8144.97	Diesel	2500	4	93.00	71	RHK	Diesel	1997	4	85.00	271
8144.97	Diesel	2500	4	93.00	72	RHK	Diesel	1997	4	85.00	349
8144.97 S	Diesel	2500	4	93.00	71	RHR	Diesel	1997	4	85.00	271
8144.97 S	Diesel	2500	4	93.00	72	RHR	Diesel	1997	4	85.00	349
8144.97 Y	Diesel	2500	4	93.00	71	Sofim-8144.61.200	Diesel	2445	4	93.00	103
8144.97 Y	Diesel	2500	4	93.00	72	Sofim-8144.61.200	Diesel	2445	4	93.00	13
831 D1.000	Diesel	1929	4	82.60	247	Sofim-8144.61.200	Diesel	2445	4	93.00	172
831 D1.000	Diesel	1929	4	82.60	264	Sofim-8144.61.200	Diesel	2445	4	93.00	44
834 B.000	Petrol	1995	4	84.00	63	Sofim-8144.61.200	Diesel	2445	4	93.00	45
834 B.048	Petrol	1995	4	84.00	62	WJZ (DW8)	Diesel	1868	4	82.20	268
834 B.146	Petrol	1995	4	84.00	64	XFW	Petrol	2946	6	87.00	361
834 C.146	Petrol	1995	4	84.00	66	XN 1T	Petrol	1971	4	88.00	98
834 G.000	Petrol	2492	6	88.00	73	XU10 (RFV)	Petrol	1998	4	86.00	352
835 C1.000	Petrol	1581	4	86.40	266	XU10J2 (RFW)	Petrol	1998	4	86.00	96
835 C1.000	Petrol	1581	4	86.40	316	XU10J2 (RFW)	Petrol	1998	4	86.00	99
835 C1.000	Petrol	1581	4	86.40	317	XUD9 (D9B/ DJZ/ 162)	Diesel	1905	4	83.00	267
835 C1.000	Petrol	1581	4	86.40	331	XUD9TF (DHV/ DHW)	Diesel	1905	4	83.00	270
835 C2.000	Petrol	1756	4	84.00	320	XUD9TF (DHV/ DHW)	Diesel	1905	4	83.00	94
835 C2.000	Petrol	1756	4	84.00	335	XUD9TF/L (DHX)	Diesel	1905	4	83.00	269
835 C4.000	Petrol	1756	4	84.00	337	XUD9TF/L (DHX)	Diesel	1905	4	83.00	348
836 A3.000	Petrol	1995	4	84.00	346	XUD9TF/L (DHX)	Diesel	1905	4	83.00	92
836 A3.000	Petrol	1995	4	84.00	55	XUD9TF/L (DHX)	Diesel	1905	4	83.00	95
836 A4.000	Petrol	1372	4	80.50	311						
836 A4.000	Petrol	1372	4	80.50	328						
836 A5.000	Petrol	1756	4	84.00	320						
838A3.000 - 838A7.000	Diesel	1910	4	82.00	84						
839 A5.000	Diesel	2387	5	82.00	170						
840A2/A4.000	Petrol	1371	4	82.00	30						
843 A1.000	Petrol	1367	4	72.00	154						
843 A1.000	Petrol	1367	4	72.00	227						
843 A1.000	Petrol	1367	4	72.00	290						
937A4.000	Diesel	1910	4	82.00	299						
937A5.000	Diesel	1910	4	82.00	295						
937A5.000	Diesel	1910	4	82.00	40						
937A7.000	Diesel	1910	4	82.00	296						
937A7.000	Diesel	1910	4	82.00	297						
939A1.000	Diesel	1910	4	82.00	149						
939A1.000	Diesel	1910	4	82.00	56						
939A2.000	Diesel	1910	4	82.00	57						
939A3.000	Diesel	2387	5	82.00	68						
A 112 B1.054	Petrol	965	4	67.20	201						
A 112 B1.054	Petrol	965	4	67.20	204						
B25.637	Diesel	2176	4	90.00	11						
CRD93L (U25-661)	Diesel	2500	4	93.00	107						
D19AA	Diesel	1910	4	82.00	277						
D8B	Diesel	1905	4	83.00	269						
D8B	Diesel	1905	4	83.00	348						
D9B (XUD9/A/B/L/Y)	Diesel	1905	4	83.00	267						
D9B (XUD9/A/B/L/Y)	Diesel	1905	4	83.00	88						
DJY	Diesel	1905	4	83.00	88						
DW10 (RHV)	Diesel	1998	4	85.00	100						
DW10 (RHX)	Diesel	1998	4	85.00	272						
DW10 (RHX)	Diesel	1998	4	85.00	275						
DW10 (RHZ)	Diesel	1998	4	85.00	274						
DW10 (RHZ)	Diesel	1998	4	85.00	276						
DW10 (RHZ)	Diesel	1998	4	85.00	354						
DW10ATED4 (RHM)	Diesel	1997	4	85.00	356						
DW10ATED4 (RHS)	Diesel	1998	4	85.00	275						
DW10ATED4 (RHS)	Diesel	1998	4	85.00	355						
DW10ATED4 (RHS)	Diesel	1998	4	85.00	357						
EW10J4 (RFN)	Petrol	1998	4	85.00	273						
EW10J4 (RFN)	Petrol	1998	4	85.00	353						
F1AE0481C	Diesel	2286	4	88.00	101						
LFW (XU7 JP)	Petrol	1762	4	83.00	347						
P8C (XUD 11 BTE)	Diesel	2088	4	85.00	359						











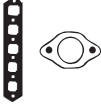

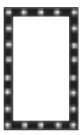

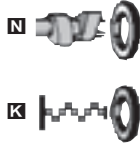





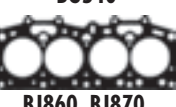
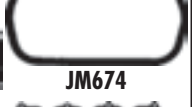

















FIAT



KW/PS



126 650		07/77 → 09/87			1	BD790 (Fibre), 1.20mm (30-026142-30)	DD790	GD671 GD790 [12]
126 A1.000/126 A1.048	652	2	77.00		18/24			
126 650		01/83 → 06/96			2	BP050 (Fibre)	DP051	GP051
141 A.000	652	2	77.00		22/30			
126 700		09/87 → 06/96			3	BT860 (Fibre) BD790 (Fibre), 1.20mm (30-026142-30)	DR480	GR480
126 A2.000/126 A2.048	704	2	80.00		18/24			
127 0.9L		06/71 → 05/83			4	BP520 (Fibre), 1.20mm (30-026522-20) BP030 (Fibre), 1.80mm (30-025210-20)	CG01A▲ → Eng.8064870 DP011■ [153] (21-26522-20/0) → Eng.8064870 DP014○ [12] DR610 [154] → Eng.8064870	GP011 → Eng.8064870
127 0.9L L/CL		01/74 →						
100 GF 000/100 GL.000/ 100 GL.000/100 GL.048 100 GL3.000/127 A.000	903	4	65.00		34/46			
	903	4	65.00	OHV	34/46			
127 1.0L		01/77 → 12/86			5	BP520 (Fibre), 1.20mm (30-026522-20) BP030 (Fibre), 1.80mm (30-025210-20)	CG01A▲ DP011■ [153] (21-26522-20/0) → Eng.8064870 DR610 Eng.8064870 →	
127 A.000	903	4	65.00	OHV	34/46			
127 1.3L D Diesel		04/81 → 12/86			6	BJ860 (Fibre), 1.65mm (30-026451-10) BJ870 (Fibre), 1.80mm, 1 Notch (30-026452-10) BJ880 (Fibre), 1.95mm, 2 Notches (30-026453-10)	DJ872▲ (21-25319-21/0)	GJ872▲
127 1.3L D Berlina Diesel		01/81 → 12/83						
127 A5.000	1301	4	76.00		33/44			
500 1.3L D Multijet Diesel		10/07 →			7		CD5810▲	ED5810 FD5810
169 A1.000	1248	4	69.60	Direct Injection, DOHC				
500 1.4L		10/07 →			8			
169 A3.000	1368	4	72.00	Injection, DOHC				
900 0.9L		01/78 → 01/86			9	BP520 (Fibre), 1.20mm (30-026522-20) BP030 (Fibre), 1.80mm (30-025210-20)	CG01A▲ → Eng.8064870 DP011■ [153] (21-26522-20/0) → Eng.8064870 DR610 [154] → Eng.8064870	GP011 → Eng.8064870
100 GF 000	903	4	65.00		34/46			
242-Serie 1.8L D Diesel		01/80 →			10	BG540 (Fibre), 1.35mm (30-027848-00)	DG542▲■○	GG541○
242-Serie Van 2.2LD Diesel		01/80 →			11	BG540 (Fibre), 1.35mm (30-027848-00)	DG542▲■○	GG541○
B25.637	2176	4	90.00	OHV	51/69			
Argenta 1600		04/81 → 12/85			12	BK540 (Fibre)	DK541	GK541
132 D.000	1585	4	84.00	DOHC	72/98			











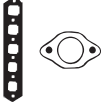

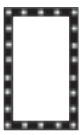

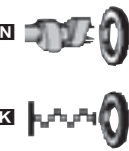





































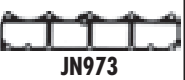



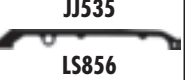



































































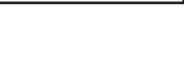















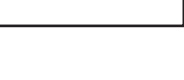









									
		JA752 (x2) JE480 (x2)	JM674	JH310	KG393 KJ156	NA5046 45x62x10mm, ACM NA5045 53x68x10mm, ACM (50-319410-00)		 BD790	 JM333
		JA752 (x2) JC134 (x2)	JM674	JH310	KG393 PA052	NB727 [152] 45x62x10mm, ACM (50-319477-00) NB728 53x68x10mm, ACM		 BG540	 JM508
		JC723 JD198 (x2) (31-027193-00)	JN666	JJ471		NA5046 45x62x10mm, ACM NA5045 53x68x10mm, ACM (50-319410-00)		 BJ860, BJ870, BJ880	 JM674
HBS109 (22-17009B) M9x1.25x60mm (x1) M9x1.25x95mm (x9)		JC973 (31-021833-10)	JM333 (31-021029-00)		HR599 (24-31919-10/0)	NB633 42x63x7mm, ACM (50-319184-00) NA5049 64x80x8mm, ACM NB808 64x80x8mm, FPM	JR154 [11] KS830 [46] KT446 [46] KT753 [46] LS649 [46]	 BK540	 JN283
		JC973 (31-021833-10)	JM333 (31-021029-00) JN283		HR599 (24-31919-10/0)	NB633 42x63x7mm, ACM (50-319184-00) NA5049 64x80x8mm, ACM NB808 64x80x8mm, FPM	JR154 [11] KS830 [46] KT446 [46] KT753 [46] LS649 [46]	 BP050	 JN417
		JD5155 (31-029308-00)	JN417 JN669 (31-025319-00) (Cork)	JJ078 JJ440 (31-027495-00)	HR596	NA5187 30x52x7mm, ACM (50-319492-00) NA5051 40x56x7mm, FPM NA5052 70x85x8mm, FPM		 BP520, BP030	 JN426
								 BT860	 JN666
								 JA752	 JN669
								 JA757	 JH111
								 JA777	 JH310
HBS247 (22-17019B) M9x1.25x87mm (x10)								 JB869	 JH310
HBS109 (22-17009B) M9x1.25x60mm (x1) M9x1.25x95mm (x9)		JC973 (31-021833-10)	JM333 (31-021029-00)			NB633 42x63x7mm, ACM (50-319184-00) NA5049 64x80x8mm, ACM NB808 64x80x8mm, FPM		 JC134	 JJ078
HBS017 (22-15008B) M12x1.50x145mm (x8) M12x1.50x118mm (x9)			JN426		HR340		KA500 [13] KA501 [13] JR529 [11]	 JC723	 JJ440
HBS017 (22-15008B) M12x1.50x145mm (x8) M12x1.50x118mm (x9)			JN426		HR340		KA500 [13] KA501 [13] JR529 [11]	 JC973	 JJ440
		JA777 (31-022714-10) (Graphite) JA757 (31-022346-10) JE388	JM085 (x2) (31-021753-00) JM508 [156] (31-021852-60)	JH111 (31-023475-00)	HR363 HR596	NA5187 30x52x7mm, ACM (50-319492-00) NB818 40x56x7mm, ACM NA5050 70x90x10mm, ACM		 JD198	 JJ471
								 JE388	
								 JE480	
								 JM085	



KW/PS



Argenta 2.4L DS Diesel		06/78 → 12/86		13		BE580 (Fibre), 1.35mm (30-024116-10)	DE588▲ [109] (21-26037-23/0)	FY291▲ [12] (20-27426-00/0)
Sofim-8144.61.200	2445	4	93.00		53/72			
Barchetta 1.7L 16V		04/95 →		14		AA5420 (MLS), 0.38mm (30-029064-00)	CA5421 (21-29064-21/0)	EA5420 (22-29064-00/0)
Barchetta 1.8i 16V		06/00 →						
188 A6.000	1747	4	82.00	Euro 3	96/131			
192 A4.000	1747	4	82.00	DOHC, Euro 3	96/131			
Barchetta Convertible 1.8Li 16V		04/95 →		15		AY500 (Fibre) [249] BW720 (Fibre), 1.65mm, (Felt) (30-028382-00)	DW723■ (21-28382-23/0)	GW723
183 A1.000/188 A6.000	1747	4	82.00		96/131			
Brava 1.2L 16V 80		12/98 → 10/00		16		AD5830 (MLS) (30-029765-00) BY380 (Fibre), 1.65mm (30-028024-30)	CE5180 (21-29832-20/0) DY382 (21-28024-22/0) →Eng.0616937	EE5180 (22-29832-00/0) GY383 (20-28024-03/0) →Eng.0616937
182 B2.000	1242	4	70.80	Injection	60/82			
Brava 1.2L 16V 80		10/00 → 10/01		17		AD5830 (MLS) (30-029765-00) BY380 (Fibre), 1.65mm (30-028024-30)	DY383 (21-28024-23/0) →Eng.0616937 CE5181 (21-29832-21/0) Eng.0616937 →	EE5180 (22-29832-00/0) GY383 (20-28024-03/0)
188 A5.000	1242	4	70.80	Injection, DOHC	59/80			
Brava 1.4L		10/95 → 10/01		18		AY480 (Fibre) [249] BX040 (Fibre), 1.20mm (30-028380-00)	DX040 (21-28380-20/0)	GX041
Brava 1.4L 12V		10/95 → 10/01						
182 A3.000	1371	4	82.00	i.e.	59/80			
182 A5.000	1371	4	82.00	i.e., SOHC	59/80			
Brava 1.6L 16V		10/95 → 10/01		19		BX030 (Fibre), 1.65mm (30-028381-00) AY470 (Fibre), 1.85mm [249] (30-029903-00)	CY470 [157] (21-29903-20/0) DX030 (21-28381-20/0)	GX030 (20-28381-00/0) →Eng.9508753
182 A6.000	1581	4	86.40		66/89			
182 A4.000	1581	4	86.40		76/103			
Brava 1.8L GT 16V		10/95 → 10/01		20		AY500 (Fibre) [249] BW720 (Fibre), 1.65mm (30-028382-00)	DW720 (21-28382-20/0)	GW724 07/99 →
182 A2.000	1747	4	82.00		96/131			

								
HBS011  (22-51004B) M12x1.25x160mm (x10) M12x1.25x119mm (x12)	JC054  (31-024274-10) JC055  (31-025031-10)	JN462 (50-024272-00) →Eng.574798 JN594 [71] (50-026037-00) Eng.574799 →	JJ100 LS856 (50-025627-00) LS857 (50-025628-00)	HR602  24-30670-61/0	NA NP068 55x70x8mm, FPM (50-303186-00) NA NP067  50x70x10mm, FPM (50-307111-70) NA NA5055  70x90x10mm, FPM	KA546 [13] KL221 [11] LS858 [11] LS859 [11]		 AA5420, BW720  AY480, BX040  AY500  BE580  BX030, AY470  BY380  JA5005  JA5006  JA5007  JC054  JC055  JD271  JD273  JD340  JD342  JD343  JD464  JD465
HBS132  (22-17015B) M10x1.25x254mm (x10)	JD271  (31-027450-10) (Metal) JD273  (31-027729-00) (MLS)	HL701  (24-28782-00/0)		HR800 	NA NA5053 30x42x7mm, FPM (50-319488-00) NA NA5069 55x68x8mm, FPM (50-319515-00) NA NA5070  31x41x7mm, FPM (50-319524-00) NA NF888  [3] 93x139.7x12mm, FPM (50-319526-00)	HL5030 [245]  KA845 [13] JS069 [45]		 JM5176  JN462  JN594  JN972  JN973  JJ100  JJ453  JJ535  LS856  LS857
HBS132  (22-17015B) M10x1.25x254mm (x10)	JD271  (31-027450-10) (Metal) JD273  (31-027729-00) (MLS)	HL701  (24-28782-00/0)	JJ535 (31-028781-00)	HR800 	NA NA5053 30x42x7mm, FPM (50-319488-00) NA NA5069 55x68x8mm, FPM (50-319515-00) NA NA5070  31x41x7mm, FPM (50-319524-00) NA NF888  [3] 93x139.7x12mm, FPM (50-319526-00)	HL5030 [245]  HJ283 [39]  JS069 [45]		 JA5005  JA5006  JA5007  JC054  JC055  JD271  JD273  JD340  JD342  JD343  JD464  JD465
HBS247  (22-17019B) M9x1.25x87mm (x10)	JD464  JD465   JF184	JM5176 (50-029831-00)	HR354 [94]	HR814  (50-319374-00)	NA NA5058 40x55x7mm, FPM NA NA5057  27x37x7mm, FPM NA NA5061  74x88x8mm, FPM	KA5032 [53] LV695 [53] JR673 [11] →06/99 KL479 [45]		 JA5007  JC054  JC055  JD271  JD273  JD340  JD342  JD343  JD464  JD465
HBS247  (22-17019B) M9x1.25x87mm (x10)	JA5005  (50-029899-00) (Rubber) JA5006  (31-029900-00)	JM5176 (50-029831-00)		HR814  (50-319374-00)	NA NA5058 40x55x7mm, FPM NA NA5057  27x37x7mm, FPM NA LK5001  [3] 74x187.5x17mm, FPM (50-319456-00)	KA5032 [53] LV695 [53]		 JA5007  JC054  JC055  JD271  JD273  JD340  JD342  JD343  JD464  JD465
HBS130  (22-17013B) M10x1.25x163mm (x10)	JD342  (31-028783-00) JD343  (31-027836-20)	JN972 (50-028784-00)	HR354 [94]	HR800 	NA NA5053 30x42x7mm, FPM (50-319488-00) NA NA5070  31x41x7mm, FPM (50-319524-00) NA NF888  [3] 93x139.7x12mm, FPM (50-319526-00)	HL5031 [245]  KA845 [13] HJ282 [39]  JS068 [11] Rubber		 JM5176  JN462  JN594  JN972  JN973  JJ100  JJ453  JJ535  LS856  LS857
HBS131  (22-17014B) M10x1.25x100mm (x10)	JD340  (31-028789-00) JD566  JD5143  (31-028790-10)	JN973 (31-028483-00)	HR354 [94] JJ453	HR800 	NA NA5187 (x2) 30x52x7mm, ACM (50-319492-00) NA NB181  40x56x7mm, ACM NA NF887  [3] 64x112.5x20mm, FPM (50-319393-00)	HJ282 [39] 		 JM5176  JN462  JN594  JN972  JN973  JJ100  JJ453  JJ535
HBS132  (22-17015B) M10x1.25x254mm (x10)	JD271  (31-027450-10) (Metal) →07/99 JA5007  07/99 → JD273  (31-027729-00) (MLS)	HL701  (24-28782-00/0)	JJ535 (31-028781-00)	HR800 	NA NA5053 30x42x7mm, FPM (50-319488-00) NA NA5069 55x68x8mm, FPM (50-319515-00) NA NA5070  31x41x7mm, FPM (50-319524-00) NA NF888  [3] 93x139.7x12mm, FPM (50-319526-00)	HL5030 [245]  KL476 [70] KA845 [13] HJ283 [39]  JS069 [45]		 JM5176  JN462  JN594  JN972  JN973  JJ100  JJ453







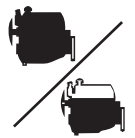



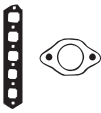

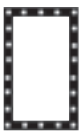





































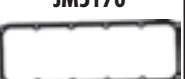



































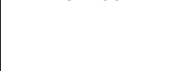



















































FIAT



KW/PS



Brava 1.8Li 16V 115ELX				01/95 → 08/99	21	AY500 (Fibre) [249]	DW723■ (21-28382-23/0)	GW723
182 A2.000/183 A1.000	1747	4	82.00	Euro 2	96/131	AW720 (Fibre), 1.65mm (30-028382-00)		
Brava 1.9L D Diesel				10/95 → 10/01	22	BT220 (Fibre), 1.65mm (30-025166-10)	DV680▲ (21-25142-26/0)	EV684 (22-25142-00/0) GV680▲ [100]
160 A7.000	1929	4	82.60		48/65	BT230 (Fibre), 1.80mm, 1 Notch BT240 (Fibre), 1.95mm, 2 Notches (30-025168-10)		
Brava 1.9L JTD Diesel				09/00 → 10/01	23	AG7390 (MLS), 0.82mm (30-030144-00)	CA5560▲ (21-29093-21/0)	EE5181 (22-29832-01/0)
182 B9.000	1910	4	82.00	Direct Injection, SOHC	74-77/ 100- 105	AA5570 (MLS), 0.92mm, 1 Hole (30-029094-10) AA5580 (MLS), 1.02mm, 2 Holes (30-029095-10)	CA5561▲ (21-29093-20/0) Eng.4081111 →	
Brava 1.9L JTD 105 Diesel				12/98 → 10/01	24	AY520 (MLS), 1.60mm, 0 Holes (30-029023-10)	CY550▲ (21-29023-20/0)	FY550▲ (20-29023-00/0)
182 B4.000	1910	4	82.00	Direct Injection, SOHC	77/105	AY530 (MLS), 1.70mm, 1 Hole (30-029024-10) AY540 (MLS), 1.80mm, 2 Holes (30-029025-10)		
Brava 1.9L TD 100 S Diesel				03/96 → 10/01	25	BY410 (Fibre), 1.60mm (30-027854-30)	DY410▲ (21-28785-20/0)	GY411▲ (20-28785-01/0)
Brava 1.9L TD 75 S Diesel				03/96 → 10/01		BY420 (Fibre), 1.70mm, 1 Notch (30-027855-30)		
182 A7.000/182 A8.000	1910	4	82.00		55/75	BY430 (Fibre), 1.80mm, 2 Notches (30-027856-30) BE440 (MLS), 1.60mm (30-028978-10) 01/99 → BE450 (MLS), 1.70mm (30-028979-10) 01/99 → BE460 (MLS), 1.80mm (30-028980-10) 01/99 →		
Bravo 1.2L 16V 80				12/98 → 10/00	26	AD5830 (MLS) (30-029765-00)	CE5180 (21-29832-20/0)	EE5180 (22-29832-00/0)
182 B2.000	1242	4	70.80	Injection	60/82	BY380 (Fibre), 1.65mm (30-028024-30)	DY382 (21-28024-22/0) → Eng.0616937	GY383 (20-28024-03/0) → Eng.0616937
Bravo 1.2L 16V 80				10/00 → 10/01	27	AD5830 (MLS) (30-029765-00)	DY383 (21-28024-23/0) → Eng.0616937	EE5180 (22-29832-00/0)
188 A5.000	1242	4	70.80	Injection, DOHC	59/80	BY380 (Fibre), 1.65mm (30-028024-30)	CE5181 (21-29832-21/0) Eng.0616937 →	GY383 (20-28024-03/0)
Bravo 1.4L				04/07 →	28	AD5830 (MLS) (30-029765-00)		EE5181 (22-29832-01/0)
Bravo 1.4L T-Jet				09/07 →				
192 B2.000	1368	4	72.00	DOHC	66/89			
198 A4.000	1368	4	72.00	Injection, DOHC	88/120			
198 A1.000	1368	4	72.00	Injection, DOHC	110/150			







								
HBS132  [22-17015B] M10x1.25x254mm (x10)	JD271  (31-027450-10) (Metal) JD273  (31-027729-00) (MLS)	HL701  [24-2878200/0]	JJ535 (31-028781-00)	HR800 	NA5053 30x42x7mm, FPM (50-319488-00) NA5069 55x68x8mm, FPM (50-319515-00) NA5070  31x41x7mm, FPM (50-319524-00) NF888  [3] 93x139.7x12mm, FPM (50-319526-00)	HL5030 [245] 	 AA5570, AA5580  AY500  AY520, AY530, AY540  BE440, BE450, BE460  BT220, BT230, BT240  BW720  BY380  BY410  BY420, BY430  JA5005  JA5006  JA5035  JC738  JD271  JD273  JD464  JD465  JD467  JD468	 JD580  JF184  HL701  JM5024  JM5028  JM5176  JN459  JP019  JP063  JJ298  JJ398  JJ535
HBS095  [22-17007B] M12x1.25x133mm (x10)	JC738 (31-026290-10)	JN459 (31-025142-10)	JJ298 (Cork) (Rubber) JJ398 (31-027379-00)	HR596 	NA5187 30x52x7mm, ACM (50-319492-00) NB742  30x43x8mm, ACM (50-319408-00) NB732  74x90x10mm, FPM NA5062  74x90x10mm, ACM	LV586 [70] LT498 [45]	 BE440, BE450, BE460  BT220, BT230, BT240  JM5176  JP019  JP063  JJ298	
HBS227  [22-17018B] M12x1.25x218mm (x10)	JA5035  (31-029407-00) JD580  JD468  (31-028377-00) (MLS)	JM5028 (31-029635-00) →Eng.4081110 JM5024  Eng.4081111 →			NA5053 30x42x7mm, FPM (50-319488-00) NA5070  31x41x7mm, FPM (50-319524-00) NF888  [3] 93x139.7x12mm, FPM (50-319526-00)	HL5031 [245] 	 BW720  BY380  BY410  BY420, BY430  JA5005  JA5006  JA5035  JC738  JD271  JD273  JD464  JD465  JD467  JD468	
HBS227  [22-17018B] M12x1.25x218mm (x10)	JD580  →02/00 JA5035  (31-029407-00) (Metal) 02/00 → JD468  (31-028377-00) (MLS)	JP063		HR363 	NA5053 30x42x7mm, FPM (50-319488-00) NA5070  31x41x7mm, FPM (50-319524-00) NF888  [3] 93x139.7x12mm, FPM (50-319526-00)	HL5031 [245]  KA845 [13]	 BY380  BY410  BY420, BY430  JA5005  JA5006  JA5035  JC738  JD271  JD273  JD464  JD465  JD467  JD468	
HBS227  [22-17018B] M12x1.25x218mm (x10)	JD467  (31-028786-00) JD468  (31-028377-00) (MLS)	JP019 (50-028785-00)		HR363 	NA5053 30x42x7mm, FPM (50-319488-00) NA5070  31x41x7mm, FPM (50-319524-00) NF888  [3] 93x139.7x12mm, FPM (50-319526-00)	HL5031 [245]  JR5001 [11]	 JA5005  JA5006  JA5035  JC738  JD271  JD273  JD464  JD465  JD467  JD468	
HBS247  [22-17019B] M9x1.25x87mm (x10)	JD464  JD465   JF184	JM5176 (50-029831-00)	HR354 [94]	HR814  (50-319374-00)	NA5058 40x55x7mm, FPM NA5057  27x37x7mm, FPM NA5061  74x88x8mm, FPM		 JD464  JD465  JD467  JD468	
HBS247  [22-17019B] M9x1.25x87mm (x10)	JA5005  (50-029899-00) (Rubber) JA5006  (31-029900-00)	JM5176 (50-029831-00)		HR814  (50-319374-00)	NA5058 40x55x7mm, FPM NA5057  27x37x7mm, FPM LK5001  [3] 74x187.5x17mm, FPM (50-319456-00)		 JD464  JD465  JD467  JD468	
HBS247  [22-17019B] M9x1.25x87mm (x10)								

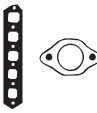

KW/PS

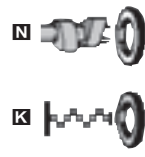

Bravo 1.4L		10/95 → 10/01			29	AY480 (Fibre) [249] BX040 (Fibre), 1.20mm (30-028380-00)	DX040 (21-28380-20/0)	GX041
182 A3.000	1371	4	82.00	i.e.	59/80			
182 A5.000	1371	4	82.00	i.e., SOHC	59/80			
Bravo 1.4L 12V S/SX		09/95 → 11/98			30	AY480 (Fibre) [249] BX040 (Fibre), 1.20mm (30-028380-00)	DX040 (21-28380-20/0)	GX041
840A2/A4.000	1371	4	82.00					
Bravo 1.6L		09/00 → 02/02			31	AB5150 (Fibre) (30-029342-00) AD5970 (MLS) (30-029779-00)	CB5150 → Eng.505169 CD5970 (21-29779-20/0) Eng.505169 →	EB5150 (22-29342-00/0) FD5970 (20-29779-00/0)
182 B6.000	1596	4	80.50	i.e.	76/103			
Bravo 1.6L 16V		10/95 → 10/01			32	BX030 (Fibre), 1.65mm (30-028381-00) AY470 (Fibre), 1.85mm [249] (30-029903-00)	CY470 [157] (21-29903-20/0) DX030 (21-28381-20/0)	EB5150 (22-29342-00/0)
182 A6.000	1581	4	86.40		66/89			
182 A4.000	1581	4	86.40		76/103			
Bravo 1.8i 16V 115GT		01/95 → 08/99			33	AY500 (Fibre) [249] BW720 (Fibre), 1.65mm (30-028382-00)	DW723 ■ (21-28382-23/0)	GW723
182 A2.000/183 A1.000	1747	4	82.00	Euro 2	96/131			
Bravo 1.8L GT		10/95 → 10/01			34	AY500 (Fibre) [249] BW720 (Fibre), 1.65mm (30-028382-00)	DW720 (21-28382-20/0) DW723 ■ (21-28382-23/0)	GW723 GW724
182 A2.000	1747	4	82.00		96/131			
Bravo 1.9L D Diesel		10/95 → 10/01			35	BT220 (Fibre), 1.65mm (30-025166-10) BT230 (Fibre), 1.80mm, 1 Notch BT240 (Fibre), 1.95mm, 2 Notches (30-025168-10)	DV680 ▲ (21-25142-26/0)	EV684 (22-25142-00/0) GV680 ▲ [100]
160 A7.000	1929	4	82.60		48/65			
Bravo 1.9L JTD Diesel		09/00 → 10/01			36	AG7390 (MLS), 0.82mm (30-030144-00) AA5570 (MLS), 0.92mm, 1 Hole (30-029094-10) AA5580 (MLS), 1.02mm, 2 Holes (30-029095-10)	CA5560 ▲ (21-29093-21/0) CA5561 ▲ (21-29093-20/0) Eng.40881111 →	EE5181 (22-29832-01/0)
182 B9.000	1910	4	82.00	Direct Injection, SOHC	74-77/ 100- 105			
Bravo 1.9L JTD 105 Diesel		12/98 → 10/01			37	AY520 (MLS), 1.60mm, 0 Holes (30-029023-10) AY530 (MLS), 1.70mm, 1 Hole (30-029024-10) AY540 (MLS), 1.80mm, 2 Holes (30-029025-10)	CY550 ▲ (21-29023-20/0)	FY550 ▲ (20-29023-00/0)
182 B4.000	1910	4	82.00	Direct Injection, SOHC	77/105			











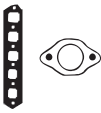

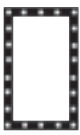

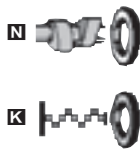































































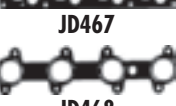

























								
HBS130 ® (22-17013B) M10x1.25x163mm (x10)	JD342 ■ (31-028783-00) JD343 ■ (31-027836-20)	JN972 (50-028784-00)	HR354 [94]	HR800 ■	NA5053 30x42x7mm, FPM (50-319488-00) NA5070 ■ 31x41x7mm, FPM (50-319524-00) NF888 ■ [3] 93x139.7x12mm, FPM (50-319526-00)	HL5031 [245]■		AA5570, AA5580 HL701 AB5150 JM5024 AD5970 JM5028 AY480, BX040 JN459 AY500 JN972 AY520, AY530, AY540 JN973 JP063 BT220, BT230, BT240 JJ298 BW720 JJ398 BX030, AY470 JA5035 JJ453 JC738 JD271 JD273 JJ535 JD340 JD342 JD343 JD468 JD5143 JD580
HBS130 ® (22-17013B) M10x1.25x163mm (x10)	JD342 ■ (31-028783-00) JD343 ■ (31-027836-20)	JN972 (50-028784-00)		HR800 ■	NA5053 30x42x7mm, FPM (50-319488-00) NA5070 ■ 31x41x7mm, FPM (50-319524-00) NF888 ■ [3] 93x139.7x12mm, FPM (50-319526-00)	HL5031 [245]■ KA845 [13] JS068 [11]		
HBS131 ® (22-17014B) M10x1.25x100mm (x10)								
HBS131 ® (22-17014B) M10x1.25x100mm (x10)	JD340 ■ (31-028789-00) JD566 ■ JD5143 ■ (31-028790-10)	JN973 (31-028483-00)	HR354 [94] JJ453	HR800 ■	NA5187 (x2) 30x52x7mm, ACM (50-319492-00) NB818 ■ 40x56x7mm, ACM NF887 ■ [3] 64x112.5x20mm, FPM (50-319393-00)	HJ282 [39]■		
HBS132 ® (22-17015B) M10x1.25x254mm (x10)	JD271 ■ (31-027450-10) (Metal) JD273 ■ (31-027729-00) (MLS)	HL701 ■ (24-28782-00/0)	JJ535 (31-028781-00)	HR800 ■	NA5053 30x42x7mm, FPM (50-319488-00) NA5069 55x68x8mm, FPM (50-319515-00) NA5070 ■ 31x41x7mm, FPM (50-319524-00) NF888 ■ [3] 93x139.7x12mm, FPM (50-319526-00)	HL5030 [245]■		
HBS132 ® (22-17015B) M10x1.25x254mm (x10)	JD271 ■ (31-027450-10) (Metal) JD273 ■ (31-027729-00) (MLS)	HL701 ■ (24-28782-00/0)	JJ535 (31-028781-00)	HR800 ■	NA5053 30x42x7mm, FPM (50-319488-00) NA5069 55x68x8mm, FPM (50-319515-00) NA5070 ■ 31x41x7mm, FPM (50-319524-00) NF888 ■ [3] 93x139.7x12mm, FPM (50-319526-00)	HL5030 [245]■		
HBS095 ® (22-17007B) M12x1.25x133mm (x10)	JC738 (31-026290-10)	JN459 (31-025142-10)	JJ298 (Cork) (Rubber) JJ398 (31-027379-00)	HR596 ■	NA5187 30x52x7mm, ACM (50-319492-00) NB742 ■ 30x43x8mm, ACM (50-319408-00) NB732 ■ 74x90x10mm, FPM NA5062 ■ 74x90x10mm, ACM	LV586 [70] LT498 [45]		
HBS227 ® (22-17018B) M12x1.25x218mm (x10)	JD580 ■ JD468 ■ (31-028377-00) (MLS)	JM5028 (31-029635-00) →Eng.4081110 JM5024 ■ Eng.4081111 →		HR363 ■	NA5053 30x42x7mm, FPM (50-319488-00) NA5070 ■ 31x41x7mm, FPM (50-319524-00) NF888 ■ [3] 93x139.7x12mm, FPM (50-319526-00)	HL5031 [245]■		
HBS227 ® (22-17018B) M12x1.25x218mm (x10)	JD580 ■ →02/00 JA5035 ■ (31-029407-00) (Metal) 02/00 → JD468 ■ (31-028377-00) (MLS)	JP063		HR363 ■	NA5053 30x42x7mm, FPM (50-319488-00) NA5070 ■ 31x41x7mm, FPM (50-319524-00) NF888 ■ [3] 93x139.7x12mm, FPM (50-319526-00)	HL5031 [245]■ KA845 [13]		



KW/PS



Bravo 1.9L TD 100 S Diesel		03/96 → 10/01		38		BY410 (Fibre), 1.60mm (30-027854-30)	DY410▲ (21-28785-20/0)	GY411▲ (20-28785-01/0)
182 A7.000/182 A8.000	1910	4	82.00		55/75	BY420 (Fibre), 1.70mm, 1 Notch (30-027855-30) BY430 (Fibre), 1.80mm, 2 Notches (30-027856-30) BE440 (MLS), 1.60mm (30-028978-10) 01/99 → BE450 (MLS), 1.70mm (30-028979-10) 01/99 → BE460 (MLS), 1.80mm (30-028980-10) 01/99 →		
Bravo 1.9L TD 75 S Diesel		03/96 → 10/01		38				
192 A8.000	1910	4	82.00	Direct Injection, SOHC				
Bravo 1.9L D Multijet Diesel		04/07 →		39				
937A5.000	1910	4	82.00	Direct Injection, DOHC	110/150	AD5840 (MLS), 0.82mm, 0 Holes (30-029766-00) AD5850 (MLS), 0.92mm, 1 Hole (30-029767-00) AD5860 (MLS), 1.02mm, 2 Holes (30-029768-00)	CD5840▲ (21-29766-20/0)	EE5181 (22-29832-01/0)
Bravo 1.9L D Multijet Diesel		04/07 →		40				
182 B7.000	1998	5	82.00	DOHC	113/154	BW320 (Fibre) (30-027452-00)	DW322 (21-27452-21/0)	
Bravo 2.0L HGT 20V		07/98 → 10/01		41				
182 A1.000	1998	5	82.00	DOHC	108/147	BW320 (Fibre) (30-027452-00)	DW320 (21-27452-20/0)	GW321
Bravo 2.0L HGT 20V		10/95 → 07/98		42				
6132 AZ 2.000	1995	4		OHV	59/80	BP190 (Fibre)	DP190	GP190
Campagnola 2.0L		06/74 → 10/89		43				
Sofim-8144.61.200	2445	4	93.00		53/72	BE580 (Fibre), 1.35mm (30-024116-10)	DE588▲ [109] (21-26037-23/0)	FY291▲ [12] (20-27426-00/0)
Campagnola 2.4L D Diesel		06/74 → 10/89		44				
Sofim-8144.61.200	2445	4	93.00		53/72	BE580 (Fibre), 1.35mm (30-024116-10)	DE588▲ [109] (21-26037-23/0)	
Campagnola 2.4L D Diesel		06/78 → 12/86		45				
170 A.000	704	2	80.00	OHV	22/30	BT860 (Fibre) BD790 (Fibre), 1.20mm (30-026142-30)	DT270■ (21-26142-21/0)	GT270
Cinquecento 0.7L		12/91 → 01/96		46				

													
HBS227  (22-17018B) M12x1.25x218mm (x10)	JD467  (31-028786-00) JD468  (31-028377-00) (MLS)	JP019 (50-028785-00)		HR363 	NA5053  30x42x7mm, FPM (50-319488-00) NA5070  31x41x7mm, FPM (50-319524-00) NF888  [3] 93x139.7x12mm, FPM (50-319526-00)	HL5031 [245]  JR5001 [11]							
HBS227  (22-17018B) M12x1.25x218mm (x10)													
HBS370  (22-17026B) M12x1.25x225mm (x10)		JM7055 (Steel Elastomer)		HR5095 									
HBS133  (22-17016B) M10x1.25x254mm (x12)	JD225  (31-027448-00) JD226  (31-028581-00)	JM5018 (Rubber)		HR800 	NA5053  30x42x7mm, FPM (50-319488-00) NA5069  55x68x8mm, FPM (50-319515-00) NA5070  31x41x7mm, FPM (50-319524-00) NF888  [3] 93x139.7x12mm, FPM (50-319526-00)	HL5030 [245] 							
HBS133  (22-17016B) M10x1.25x254mm (x12)	JD225  (31-027448-00) JD226  (31-028581-00)	JN933 (50-028787-00)		HR800 	NA5053  30x42x7mm, FPM (50-319488-00) NA5069  55x68x8mm, FPM (50-319515-00) NA5070  31x41x7mm, FPM (50-319524-00) NF888  [3] 93x139.7x12mm, FPM (50-319526-00)	HL5030 [245]  KA845 [13]							
	JB605 (x2)  JE390  (31-021632-10)		JH111 (31-023475-00)	HR596 									
HBS011  (22-51004B) M12x1.25x160mm (x10) M12x1.25x119mm (x12)	JC054  (31-024274-10) JC055  (31-025031-10)	JN462 (50-024272-00) →Eng.574798 JN594 [71] (50-026037-00)		HR662 	NP067  50x70x10mm, FPM (50-307111-70) NP068  55x70x8mm, FPM (50-303186-00) NA5055  70x90x10mm, FPM								
HBS011  (22-51004B) M12x1.25x160mm (x10) M12x1.25x119mm (x12)	JC054  (31-024274-10) JC055  (31-025031-10)	JN462 (50-024272-00) →Eng.574798 JN594 [71] (50-026037-00) Eng.574799 →	JJ100	HR602  24-30670-61/0	NP068  55x70x8mm, FPM (50-303186-00) NP067  50x70x10mm, FPM (50-307111-70) NA5055  70x90x10mm, FPM								
	JD067  (31-027453-00) JD198  (x2) (31-027193-00)	JN804 (50-027454-00)	JJ471		NA5060  45x62x8mm, FPM NA5059  53x68x10mm, FPM								







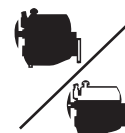



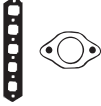

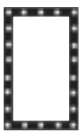

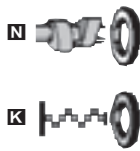





















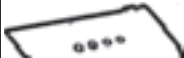

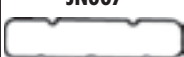









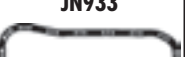
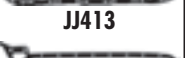

























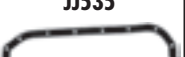



















































FIAT



KW/PS



Cinquecento 0.9L 07/91 → 12/93 47					AY430 (Fibre) (30-028975-00)	DT260 (21-27165-20/0)	GT260 [158] (20-27165-00/0)
Cinquecento 0.9L i.e. 07/91 → 12/93					BT260 (Fibre) (30-027165-10)		
170 A1.000/170 A1.046	903	4	65.00	SOHC	30/41		
Cinquecento 0.9L i.e. S 07/91 → 01/98 48					AY430 (Fibre) (30-028975-00)	DT260 (21-27165-20/0)	GT260 [158] (20-27165-00/0)
1170 A1.000	899	4	65.00	SOHC	29-30/ 40-41		
1170 A1.046	899	4	65.00	SOHC	30/41		
Cinquecento 1.1L Sporting 10/94 → 01/98 49					BP280 (Fibre), 1.65mm (30-026046-30)	DV675 (21-27165-00/0)	EP280 GP285
176 B2.000	1108	4	70.00	SPI	40/54		
Coupe 1.8L 16V 03/96 → 08/00 50					AY500 (Fibre) [249]	DW723 ■ (21-28382-23/0)	GW723
183 A1.000	1747	4	82.00		96/131		
Coupe 2.0L 16V Turbo 11/93 → 08/96 51					BW720 (Fibre), 1.65mm, (Felt) (30-028382-00)		
175 A1.000	1995	4	84.00	Injection, DOHC	137/186		
Coupe 2.0L 20V 04/98 → 08/00 52					BT440 (Fibre) (30-026647-30)	DT447 (21-26647-27/0)	GT447
182 B3.000	1998	5	82.00		113/154		
Coupe 2.0L 20V 08/96 → 04/98 53					BW320 (Fibre) (30-027452-00)	DW322 (21-27452-21/0)	ED5960 (22-29778-00/0)
182 A1.000	1998	5	82.00	DOHC	108/147		
Coupe 2.0L 20V Turbo 08/96 → 08/00 54					BW320 (Fibre) (30-027452-00)	DW320 (21-27452-20/0)	GW321
175 A3.000	1998	5	82.00		162/220		
Coupe 2.0Li 16V 11/93 → 08/96 55					AY320 (MLS), 1.80mm (30-029072-00)	CY320 (21-29813-20/0)	FY320 (20-29813-00/0)
836 A3.000	1995	4	84.00	injection	109/148		
Coupe 2.0Li 16V 11/93 → 08/96 55					BT440 (Fibre) (30-026647-30)	DT448	GT448

								
HBS297  [22-17022B] M9x1.25x91mm (x9) M9x1.25x56mm (x1)	JC973  (31-021833-10)	JN803 (50-027374-00)	JJ449 JJ605 03/98 →	HR599  (24-31919-10/0)	 NB633 42x63x7mm, ACM (50-319184-00)  NA5177 42x56x7mm, FPM (50-319189-00)  NB808 64x80x8mm, FPM	KA295 [13] KT600 [11]	 AY320  AY430, BT260  AY500  BP280, BV940  BT440  BW320  BW720  JC973  JD148  JD151  JD152  JD153  JD225  JD226  JD271  JD273  JD5375  HL701  JM5018  JN667 JN803	
HBS297  [22-17022B] M9x1.25x91mm (x9) M9x1.25x56mm (x1)	JC973  (31-021833-10)	JN803 (50-027374-00)	JJ449 JJ605	HR599  (24-31919-10/0)	 NB633 42x63x7mm, ACM (50-319184-00)  NA5177 42x56x7mm, FPM (50-319189-00)  NB808 64x80x8mm, FPM		 JN928  JN933  JJ413  JJ449  JJ535  JJ605	
HBS052  [22-17006B] M9x1.25x95mm (x10)	JD148  (31-025907-10) JD5375  (x2) (31-029968-00)	JN667 (50-026094-00)	HR354 [94]	HR599  (24-31919-10/0)	 NA5053 30x42x7mm, FPM (50-319488-00)  NB815 23x35x7mm, FPM (50-319523-00)  NA5061 74x88x8mm, FPM	HL5024 [245]  KA5032 [53] LV695 [53] JR673 [11] LB177 [46]	 JN928  JJ449  JJ535  JJ605	
HBS132  [22-17015B] M10x1.25x254mm (x10)	JD271  (31-027450-10) (Metal) JD273  (31-027729-00) (MLS)	HL701  (24-28782-00/0)	JJ535 (31-028781-00)	HR800 	 NA5053 30x42x7mm, FPM (50-319488-00)  NA5069 55x68x8mm, FPM (50-319515-00)  NA5070 31x41x7mm, FPM (50-319524-00)  NF888 [3] 93x139.7x12mm, FPM (50-319526-00)	HL5030 [245]  KL476 [70] HJ283 [39]  JS069 [45] KK5158 [45]	 JN928  JJ449  JJ535  JJ605	
HBS093  [22-17005B] M10x1.25x172mm (x10)	JD151 (31-027331-00) JD152  (31-027272-00)	JN928 [102] (50-027319-00)	JJ413 (31-027315-00)		 NA5053 30x42x7mm, FPM (50-319488-00)  NB742 30x43x8mm, ACM (50-319408-00)  NB732 74x90x10mm, FPM (50-319408-00)  NA5062 74x90x10mm, ACM	JS081 [11] KT639 [11]	 JN928  JJ449  JJ535  JJ605	
HBS133  [22-17016B] M10x1.25x254mm (x12)	JD225  (31-027448-00) JD226  (31-028581-00)	JM5018 (Rubber)	HR354 [94]	HR800 	 NA5053 30x42x7mm, FPM (50-319488-00)  NA5069 55x68x8mm, FPM (50-319515-00)  NA5070 31x41x7mm, FPM (50-319524-00)  NF888 [3] 93x139.7x12mm, FPM (50-319526-00)	HL5030 [245]  KA845 [13]	 JN928  JJ449  JJ535  JJ605	
HBS133  [22-17016B] M10x1.25x254mm (x12)	JD225  (31-027448-00) JD226  (31-028581-00)	JN933 (50-028787-00)	HR354 [94]	HR800 	 NA5053 30x42x7mm, FPM (50-319488-00)  NA5069 55x68x8mm, FPM (50-319515-00)  NA5070 31x41x7mm, FPM (50-319524-00)  NF888 [3] 93x139.7x12mm, FPM (50-319526-00)	HL5030 [245]  KA845 [13]	 JN928  JJ449  JJ535  JJ605	
HBS133  [22-17016B] M10x1.25x254mm (x12)	JD225  (31-027448-00) JD226  (31-028581-00)	JN933 (50-028787-00)	HR354 [94]	HR800 	 NA5053 30x42x7mm, FPM (50-319488-00)  NA5069 55x68x8mm, FPM (50-319515-00)  NA5070 31x41x7mm, FPM (50-319524-00)  NF888 [3] 93x139.7x12mm, FPM (50-319526-00)	HL5030 [245]  KA845 [13]	 JN928  JJ449  JJ535  JJ605	
HBS093  [22-17005B] M10x1.25x172mm (x10)	JD153  (31-027321-00) JD151 (31-027331-00)	JN928 [102] (50-027319-00)	JJ413 (31-027315-00)		 NA5053 30x42x7mm, FPM (50-319488-00)  NB742 30x43x8mm, ACM (50-319408-00)  NB732 74x90x10mm, FPM (50-319408-00)  NA5062 74x90x10mm, ACM	KT639 [11]	 JN928  JJ449  JJ535	

FIAT



KW/PS













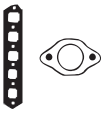

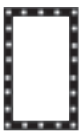

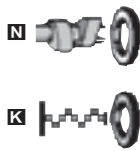



















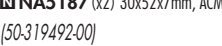
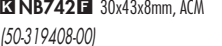

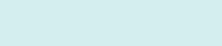



















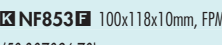
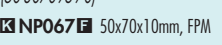











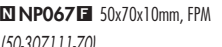
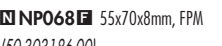
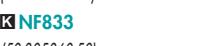











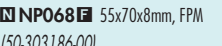
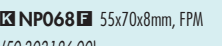





HBS227 (22-17018B) M12x1.25x218mm (x10) HBS465 (22-17029B) M12x1.50x220mm (x10)					NA5053 30x42x7mm, FPM (50-319488-00) NA5070 31x41x7mm, FPM (50-319524-00) NF888 [3] 93x139.7x12mm, FPM (50-319526-00)			AC5169 AC5170 BT300, BT320 BT410 BT440, BT420 JA757 JC661 JC662 JD013 JD151 JD153 JN643, JN819 JN645 JN809 JN928 JN948 LB414 JJ298 JJ413		
HBS370 (22-17026B) M12x1.25x225mm (x10) HBS465 (22-17029B) M12x1.50x220mm (x10)		JM7055 (Steel Elastomer)		HR5095	NA5070 31x41x7mm, FPM (50-319524-00) NF888 [3] 93x139.7x12mm, FPM (50-319526-00)					
HBS097 (22-17010B) M12x1.25x120mm (x10)	JD013	JN809 (50-027378-00)		HR569 24-30667-00/0	NA5053 30x42x7mm, FPM (50-319488-00) NB742 30x43x8mm, ACM (50-319408-00) NB732 74x90x10mm, FPM NA5062 74x90x10mm, ACM	LB175 [70] LTO21 [13][164]				
HBS092 (22-17003B) M10x1.25x115mm (x10)	JC661 JA757 (31-022346-10)	JN643 (31-027225-00) JN819 (x2) JN948 (x2) (31-027428-00)	JJ413 (31-027315-00)	HR363						
HBS093 (22-17005B) M10x1.25x172mm (x10)	JD153 (31-027321-00) JD151 (31-027331-00)	JN928 [102] (50-027319-00)	JJ413 (31-027315-00)		NA5053 30x42x7mm, FPM (50-319488-00) NB742 30x43x8mm, ACM (50-319408-00)	LB025 [13] KT465 [54]				
HBS092 (22-17003B) M10x1.25x115mm (x10)	JC661 JA757 (31-022346-10)	JN643 (31-027225-00) JN645 [156] (31-027441-00) →Eng.1239615 LB414 [156]	JJ413 (31-027315-00)	HR363 HR569 24-30667-00/0	NA5187 (x2) 30x52x7mm, ACM (50-319492-00) NB742 30x43x8mm, ACM (50-319408-00) NB732 74x90x10mm, FPM	LV585 [45]				
HBS092 (22-17003B) M10x1.25x115mm (x10)				HR363	NB742 30x43x8mm, ACM (50-319408-00) NB732 74x90x10mm, FPM					
HBS092 (22-17003B) M10x1.25x115mm (x10)	JC662 (31-026050-10) JA757 (31-022346-10)	JN643 (x2) (31-027225-00) LB414 [156]	JJ298 JJ413 (31-027315-00)	HR363	NB742 30x43x8mm, ACM (50-319408-00) NB732 74x90x10mm, FPM NA5062 74x90x10mm, ACM	LB175 [70] OK627 [14] JR749 [11] KT639 [11] LV585 [45] OK473 [160] LA055 [56]				
HBS092 (22-17003B) M10x1.25x115mm (x10)	JC662 (31-026050-10) JA757 (31-022346-10)	JN643 (x2) (31-027225-00) JN948 (31-027428-00)	JJ413 (31-027315-00)	HR363	NA5187 (x2) 30x52x7mm, ACM (50-319492-00) NB742 30x43x8mm, ACM (50-319408-00) NB732 74x90x10mm, FPM NA5062 74x90x10mm, ACM					

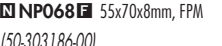

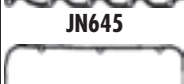
KW/PS

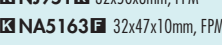
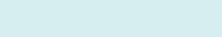

Croma 2000 i.e. Turbo				12/85 → 06/90		65	BT420 (Fibre) (30-025413-10) → Eng.1239615		DT420 (21-25413-21/0) → Eng.1239615
154 A2.000	1995	4	84.00			114/155			
Croma 2000 i.e. Turbo				11/86 → 08/96		66	BT410 (Fibre) BT420 (Fibre) (30-025413-10)		DT420 (21-25413-21/0) → Eng.1033481 DT413 Eng.1033482 →
834 C.146	1995	4	84.00	Injection, DOHC		110- 112/ 150- 152			
154 C4.046	1995	4	84.00	Injection		113/154			
Croma 2.2L 16V				06/05 →		67	AG9580 (MLS) (30-030344-00)		
194A1.000	2198	4	86.00	DOHC		108/147			
Croma 2.4L D Multijet Diesel				06/05 →		68	AG7410 (MLS) (30-030146-00) 06/04 → AG7420 (MLS) (30-030147-00) 06/04 → AG7430 (MLS) (30-030148-00) 06/04 →		CG7410 (21-30146-00/0) 06/04 → EG7410 (22-30146-00/0) 06/04 →
939A3.000	2387	5	82.00	Direct Injection, DOHC		147/200			
Croma 2.5 D DS Diesel				10/85 →		69	BP270 (Fibre), 1.65mm (30-026650-20)		DP273▲ (21-26100-21/0)
Croma 2500 TD Diesel				12/85 → 08/89			BR090 (Fibre), 1.80mm [161] (30-026651-20)		GT750▲ (20-26100-00/0)
8144.91	2445	4	93.00	Sofim, SOHC, Turbo Intercooled		76/103			
8144.91	2445	4	93.00	SOHC		76/103			
Croma 2500 D Diesel				12/85 → 12/89		70	BG450 (Fibre), 1.35mm (30-025842-10) AY290 (Fibre), 1.60mm [112] (30-027426-00) AY300 (Fibre), 1.70mm [112] (30-026654-20) AY310 (Fibre), 1.80mm [112] (30-026655-20)		DE588▲ [109] (21-26037-23/0) FY291▲ [12] (20-27426-00/0)
8144.67	2500	4	93.00	Indirect Injection, SOHC		55/75			
Croma 2500 TD Diesel				05/89 → 08/96		71	AY290 (Fibre), 1.60mm [112] (30-027426-00) BP270 (Fibre), 1.65mm (30-026650-20) AY300 (Fibre), 1.70mm [112] (30-026654-20) AY310 (Fibre), 1.80mm [112] (30-026655-20) BR090 (Fibre), 1.80mm [161] (30-026651-20)		DP273▲ (21-26100-21/0) GT750▲ (20-26100-00/0)
8144.97	2500	4	93.00	Sofim, SOHC, Turbo Intercooled		85/115			
8144.97 S	2500	4	93.00	Sofim, Turbo Intercooled		85/115			
8144.97 Y	2500	4	93.00	Sofim, SOHC, Turbo Intercooled		85/115			
Croma 2500 TDE Diesel				12/91 → 08/96		72	AY290 (Fibre), 1.60mm [112] (30-027426-00) AY300 (Fibre), 1.70mm [112] (30-026654-20) AY310 (Fibre), 1.80mm [112] (30-026655-20)		DP273▲ (21-26100-21/0) GT750▲ (20-26100-00/0)
8144.97	2500	4	93.00	Sofim, SOHC, Turbo Intercooled		85/115			
8144.97 S	2500	4	93.00	Sofim, Turbo Intercooled		85/115			
8144.97 S	2500	4	93.00	Sofim, SOHC, Turbo Intercooled		85/115			
8144.97 Y	2500	4	93.00	Sofim, SOHC, Turbo Intercooled		85/115			
Croma 2500 V6				06/93 → 08/96		73	BW300 (Fibre) ☒ (30-025874-20) BW310 (Fibre) ☒ (30-025875-20)		DW301 GW301
834 G.000	2492	6	88.00	V6		121/165			











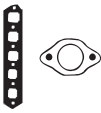

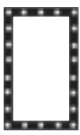

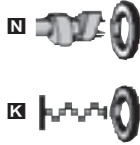

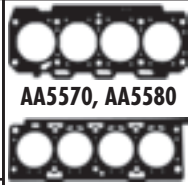









								
HBS092  (22-17003B) M10x1.25x115mm (x10)	JC662  (31-026050-10) JD019  (31-027032-10) 01/92 →  JF043	JN643 (x2) (31-027225-00) JN645 [156] (31-027441-00) →Eng.1239615 JN947 →Eng.1239615	JJ298 →Eng.1239615 JJ413 (31-027315-00)	HR363  HR569  24-30667-00/0		LB025 [13][159] KT639 [11] LV585 [45]		 AY290, AY300, AY310  JN808  JN947  BG450  BP270, BR090  LB414  JJ100
HBS092  (22-17003B) M10x1.25x115mm (x10)	JC662  (31-026050-10) JA757  (31-022346-10)	JN643 (x2) (31-027225-00) LB414  [156]	JJ413 (31-027315-00)	HR363 	 NA5187 (x2) 30x52x7mm, ACM (50-319492-00)  NB742 30x43x8mm, ACM (50-319408-00)  NB732 74x90x10mm, FPM  NA5062 74x90x10mm, ACM			 BT410  BT420  JJ298  BW300  JJ317
HBS416  (22-29025B) M11x1.50x163mm (x10)	KG5337  (50-350435-00) (MVQ) JD5868  (31-030346-00)							 BW310  JA757  JC054  JC055  JJ413  LS856  LS857
HBS011  (22-51004B) M12x1.25x160mm (x10) M12x1.25x119mm (x12)	JC054  (31-024274-10) JC055  (31-025031-10)	JN585 (50-026100-00)	JJ317 (31-026102-00) LS857 (50-025628-00)	HR602  24-30670-61/0	 NF853 100x118x10mm, FPM (50-307096-70)  NP067 50x70x10mm, FPM (50-307111-70)	KA546 [13] LS858 [11]		 JC662  JD019  JD222  JD223  JF043
HBS011  (22-51004B) M12x1.25x160mm (x10) M12x1.25x119mm (x12)	JC054  (x4) (31-024274-10) JC055  (x4) (31-025031-10)	JN462 (50-024272-00) →Eng.574798 JN594 [71] (50-026037-00)	JJ100 LS856  (50-025627-00) LS857  (50-025628-00)	HR602  24-30670-61/0 HR782 	 NP067 50x70x10mm, FPM (50-307111-70)  NP068 55x70x8mm, FPM (50-303186-00)  NF833 (50-305860-50)  NA5055 70x90x10mm, FPM	KA546 [13] JR580 [11] KL221 [11] LS859 [11]  LS858 [11] 		 JN462  JN585  JN594
HBS011  (22-51004B) M12x1.25x160mm (x10) M12x1.25x119mm (x12)	JC054  (31-024274-10) JC055  (31-025031-10)	JN585 (50-026100-00)	JJ317 (31-026102-00) LS857 (50-025628-00)	HR602  24-30670-61/0 HR781 	 NP068 55x70x8mm, FPM (50-303186-00)  NP068 55x70x8mm, FPM (50-303186-00)	KA546 [13] LS858 [11]		 JN642  JN643  JN645
HBS011  (22-51004B) M12x1.25x160mm (x10) M12x1.25x119mm (x12)	JC054  (31-024274-10) JC055  (31-025031-10)	JN585 (50-026100-00)	JJ317 (31-026102-00) LS857 (50-025628-00)	HR602  24-30670-61/0 HR781 	 NP068 55x70x8mm, FPM (50-303186-00)  NP068 55x70x8mm, FPM (50-303186-00)	KA546 [13] LS858 [11]		 JN643  JN645
	JD222  (31-027279-00) JD223  (x6) (31-027287-00)	JN808  (31-027281-00) JN807  (31-027280-00)			 NJ951 32x50x8mm, FPM  NA5163 32x47x10mm, FPM	KA738 [13]		 JN807



KW/PS



Doblo 1.2L 03/01 → 74					AE5240 (MLS) (30-029844-00) AE5550 (Fibre) [249] (30-029928-00) BV670 (Fibre) (30-027185-00)	CE5240 [162] (21-29844-20/0) DV672 [163] (21-27185-22/0) DV675 (21-27185-00/0)	EV670 (22-27185-00/0)
223 A5.000	1242	4	70.80	SPI	44/60		
Doblo 1.3L D Multijet Diesel 10/05 → 75						CD5820 ▲	ED5820 FD5820 ▲
223 A9.000	1248	4	69.60	Direct Injection, DOHC			
Doblo 1.3L D Multijet Diesel 10/05 → 76						CD5810 ▲	ED5810 FD5810
199 A2.000	1248	4	69.60	Direct Injection, DOHC	55/75		
Doblo 1.3L JTD Diesel 05/05 → 77						CD5810 ▲	ED5810 FD5810
199 A2.000	1248	4	69.60	Direct Injection, DOHC	55/75		
Doblo 1.3L JTD 16V Diesel 05/04 → 78					AD5800 (MLS), 0.72mm (30-029762-00) AD5810 (MLS), 0.82mm, 1 Hole (30-029763-00) AD5820 (MLS), 0.92mm, 2 Holes (30-029764-00)	CD5810 ▲	ED5810 FD5810
188 A9.000	1248	4	69.60	Direct Injection, DOHC	51/70		
Doblo 1.4L 10/05 → 79					AG7380 (MLS) (30-030143-00)	CG7380 (21-30143-00/0) 01/05 →	
350 A1.000	1368	4	72.00	Injection, SOHC	57-55/ 78-75		
Doblo 1.6L 09/02 → 80					AB5150 (Fibre) (30-029342-00) AD5970 (MLS) (30-029779-00)	CB5150 CD5970 (21-29779-20/0)	EB5150 (22-29342-00/0) FD5970 (20-29779-00/0)
182 B6.000	1596	4	80.50	i.e.	76/103		
Doblo 1.6L 16V 10/01 → 81					AB5150 (Fibre) (30-029342-00) →Eng.505168 AD5970 (MLS) (30-029779-00) Eng.505169 →	CB5150 →Eng.505168 CD5970 (21-29779-20/0)	EB5150 (22-29342-00/0) FD5970 (20-29779-00/0)
Doblo 1.6L Natural Power 09/02 →							
182 B6.000	1596	4	80.50	i.e.	76/103		
Doblo 1.9L D Diesel 03/01 → 82					BZ790 (MLS), 0.80mm (30-028707-00) BZ800 (MLS), 0.90mm, 1 Notch (30-028708-00) BZ810 (MLS), 1.00mm, 2 Notches (30-028709-00)	DZ790 ▲ (21-28707-20/0)	GZ790 ▲
223 A6.000	1910	4	82.00		44/60		
Doblo 1.9L D Multijet Diesel 10/05 → 83					AG7390 (MLS), 0.82mm (30-030144-00) AA5570 (MLS), 0.92mm, 1 Hole (30-029094-10) AA5580 (MLS), 1.02mm, 2 Holes (30-029095-10)	CA5561 ▲ (21-29093-20/0)	EE5181 (22-29832-01/0)
Doblo 1.9L JTD Diesel 07/03 →							
223 A7.000	1910	4	82.00	Indirect Injection, SOHC	77/105		
186A9.000	1910	4	82.00	Direct Injection	88/120		
223 B1.000	1910	4	82.00	Direct Injection, SOHC			

									
HBS052 (22-17006B) M9x1.25x95mm (x10)	JA5010 JD5375 (x2) (31-029968-00)	JM5019	HR354 [94]	HR599 (24-31919-10/0)	NA5053 30x42x7mm, FPM (50-319488-00) NB815 23x35x7mm, FPM (50-319523-00) NA5061 74x88x8mm, FPM	KA5032 [53] LV695 [53] JR673 [11] LB177 [46]		AB5150  AD5800  AD5810  AD5820  AD5970  AE5240  BV670  BZ790, BZ800, BZ810 	JD5412  JM5003  JM5019  JN973 
HBS353 (22-17025B) M10x1.25x119mm (x10)									
HBS353 (22-17025B) M10x1.25x119mm (x10)									
HBS353 (22-17025B) M10x1.25x119mm (x10)	JD5411 (50-030025-00) JD5412 (50-030026-00) JD5413 (31-030027-00) (MLS)	JM5259 (31-030023-00)		HR5088 (24-31952-10/0)	NA5223 40x52x7mm, FPM (50-319520-00) NA5230 78x100x9mm, PTFE (50-319522-00)	KK5646 [45]			
HBS052 (22-17006B) M9x1.25x95mm (x10)					NA5058 40x55x7mm, FPM				
HBS131 (22-17014B) M10x1.25x100mm (x10)		JN973 (31-028483-00)			NA5187 30x52x7mm, ACM (50-319492-00) NF887 [3] 64x112.5x20mm, FPM (50-319393-00)				
HBS131 (22-17014B) M10x1.25x100mm (x10)	JD340 (31-028789-00) JD566 JD5143 (31-028790-10)	JN973 (31-028483-00)			NA5187 (x2) 30x52x7mm, ACM (50-319492-00) NB818 40x56x7mm, ACM NF887 [3] 64x112.5x20mm, FPM (50-319393-00)			JA5008  JA5010  JA5011 	
HBS227 (22-17018B) M12x1.25x218mm (x10)	JA5008 (31-029958-00) (Rubber) JA5011 (31-029959-00) (Rubber) JD468 (31-028377-00) (MLS)	JM5003 (50-029960-00)		HR363	NA5053 30x42x7mm, FPM (50-319488-00) NA5070 31x41x7mm, FPM (50-319524-00) NF888 [3] 93x139.7x12mm, FPM (50-319526-00)	HL5031 [245] KL476 [70] KA845 [13] JR5001 [11] KK5004 [155]		JD340  JD468  JD5143  JD5375 	
HBS227 (22-17018B) M12x1.25x218mm (x10)					NA5053 30x42x7mm, FPM (50-319488-00) NA5070 31x41x7mm, FPM (50-319524-00) NF888 [3] 93x139.7x12mm, FPM (50-319526-00)				



KW/PS



Doblo 1.9L JTD Diesel				10/01 →	84			AG7390 (MLS), 0.82mm (30-030144-00)	CA5560▲ (21-29093-21/0)	FA5560▲ (20-29095-00/0)
Doblo 1.9L JTD Cargo Diesel				10/01 →				AA5570 (MLS), 0.92mm, 1 Hole (30-029094-10)	CA5561▲ (21-29093-20/0)	
182 B9.000	1910	4	82.00	Direct Injection, SOHC, Turbo Intercooled	74-77/ 100- 105			AA5580 (MLS), 1.02mm, 2 Holes (30-029095-10)	Eng.4081111 →	
182 B9.000	1910	4	82.00	Direct Injection, SOHC	74-77/ 100- 105					
838A3.000 - 838A7.000	1910	4	82.00		74-77/ 100- 105					
223 B2.000	1910	4	82.00	Direct Injection, SOHC						
Doblo 1.9L JTD Diesel				07/03 →	85			AG7390 (MLS), 0.82mm (30-030144-00)	CA5561▲ (21-29093-20/0)	
223 A7.000	1910	4	82.00	Indirect Injection, SOHC	77/105			AA5570 (MLS), 0.92mm, 1 Hole (30-029094-10)		
223 B1.000	1910	4	82.00	Direct Injection, SOHC				AA5580 (MLS), 1.02mm, 2 Holes (30-029095-10)		
Ducato 1.8L				07/82 →12/88	86					
	1783	4			51/67					
Ducato 1.8L				01/82 →10/88	87				DM710○	
169 B (XM7T)	1783	4	84.00	OHV	49/67					
Ducato 1.9L D Diesel				04/98 →04/02	88			BX880 (Fibre), 1.36mm, 1 Notch (30-028475-00)	DJ720▲ (21-25202-22/0)	EL890 (22-25198-01/0)
D9B (XUD9/A/B/L/Y)	1905	4	83.00		49/67			→0.56 →0.67mm		GJ720▲ (20-25202-02/0)
DJY	1905	4	83.00	SOHC	50/68			BX890 (Fibre), 1.40mm, 2 Notches (30-028476-00)		
								→0.68 →0.71mm		
								BX900 (Fibre), 1.44mm, 3 Notches (30-028477-00)		
								→0.72 →0.75mm		
								BX910 (Fibre), 1.48mm, 4 Notches (30-028478-00)		
								→0.76 →0.79mm		
								BX920 (Fibre), 1.52mm, 5 Notches (30-028479-00)		
								→0.80 →0.83mm		

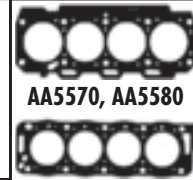
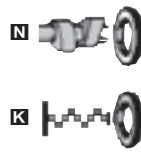
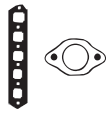

AA5570, AA5580



JA5035



JD468



JD580



JM5028



JM5204



JN462



JN594



KW/PS



Ducato 1.9L D Diesel					03/94 → 04/02	89	BR680 (Graphite), 1.65mm		DV680▲	EV684
Ducato 1.9L D Combinato Diesel					06/95 → 04/02		BT220 (Fibre), 1.65mm		(21-25142-26/0)	(22-25142-00/0)
230 A2.000	1929	4	82.60	SOHC		60/81	AC5140 (MLS), 1.66mm (30-026296-20) BV680 (Fibre), 1.67mm, 0 Notches (30-026296-10) AC5150 (MLS), 1.76mm (30-026297-20) BR690 (Graphite), 1.80mm, 1 Notch (30-025167-10) AC5180 (MLS), 1.86mm (30-027859-20) BR700 (Graphite), 1.95mm, 2 Notches (30-026298-10) AC5160 (MLS), 1.96mm (30-026298-20)			GV680▲ [100]
Ducato 1.9L D Diesel					02/87 → 03/94	90	BR680 (Graphite), 1.65mm		DV680▲	EV684
Ducato 1.9L TD Diesel					03/94 → 04/02		BV680 (Fibre), 1.67mm, 0 Notches		(21-25142-26/0)	(22-25142-00/0)
Ducato 1.9L TD Panorama/Combinato Diesel					03/94 → 04/02		(30-026296-10) BV690 (Fibre), 1.75mm, 1 Notch BV700 (Fibre), 1.85mm, 2 Notches (30-027859-00) BW980 (Fibre), 1.93mm, 3 Notches <td></td> <td>GV680▲ [100]</td>			GV680▲ [100]
149 B1.000	1929	4	82.60	SOHC		52/71				
230 A3.000/230 A4.000	1929	4	82.60			60/81				
Ducato 1.9L TD Diesel					03/89 → 03/94	91	BR680 (Graphite), 1.65mm		DV680▲	EV684
280 A1.000	1929	4	82.60			60/81	BV680 (Fibre), 1.67mm, 0 Notches (30-026296-10) BR690 (Graphite), 1.80mm, 1 Notch (30-025167-10) BR700 (Graphite), 1.95mm, 2 Notches (30-026298-10)		(21-25142-26/0)	(22-25142-00/0)
										GV680▲ [100]
Ducato 1.9L TD Diesel					04/98 → 04/02	92	BX930 (Steel Elastomer), 1.36mm, 1 Notch		DJ720▲	EL890
XUD9TF/L (DHX)	1905	4	83.00	SOHC		66/89	(30-028503-00) BX940 (Steel Elastomer), 1.40mm, 2 Notches (30-028504-00) BX950 (Steel Elastomer), 1.44mm, 3 Notches (30-028505-00) BX960 (Steel Elastomer), 1.48mm, 4 Notches (30-028506-00) BX970 (Steel Elastomer), 1.52mm, 5 Notches (30-028507-00) BX980 (Steel Elastomer), 1.59mm ☞0.83mm →		(21-25202-22/0) →Eng.08574	(22-25198-01/0) GJ720▲ (20-25202-02/0) Eng.08575 →
Ducato 1.9L TD Diesel					03/94 → 04/02	93	BR680 (Graphite), 1.65mm		DV680▲	EV684
Ducato 1.9L TD CAT Diesel					08/94 → 04/02		AC5140 (MLS), 1.66mm		(21-25142-26/0)	(22-25142-00/0)
Ducato 1.9L TD Combinato Diesel					08/94 → 04/02		(30-026296-20) BV680 (Fibre), 1.67mm, 0 Notches (30-026296-10) BV690 (Fibre), 1.75mm, 1 Notch AC5150 (MLS), 1.76mm (30-026297-20) BV700 (Fibre), 1.85mm, 2 Notches (30-027859-00) AC5180 (MLS), 1.86mm (30-027859-20) BW980 (Fibre), 1.93mm, 3 Notches AC5160 (MLS), 1.96mm (30-026298-20) <td></td> <td>GV680▲ [100]</td>			GV680▲ [100]
230 A3.000/230 A4.000	1929	4	82.60			60/81				

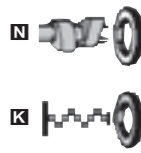
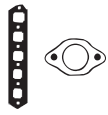

AC5160, AC5140,
AC5150, AC5180



BR680, BR690,
BR700



BT220



BV690, BV700,
BW980, BV680



BX930, BX940,
BX950, BX960,
BX970, BX980



JC738



JC759



JN459



JN544



JJ298









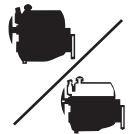



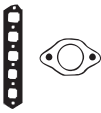

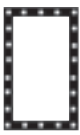

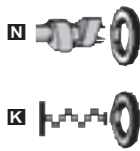

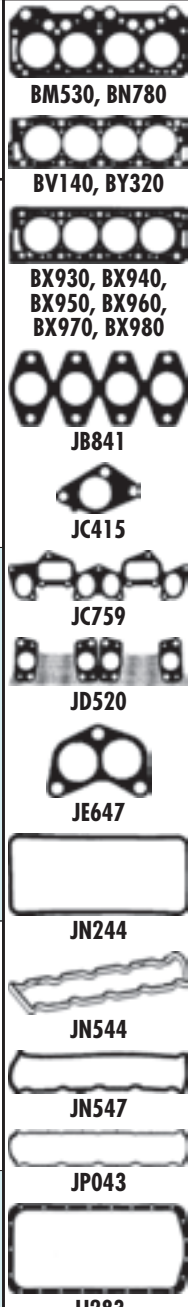









































JJ398



KW/PS



Ducato 1.9L TD Diesel		04/98 → 04/02		94			
XUD9TF (DHV/ DHW)	1905	4	83.00	Turbo	BX930 (Steel Elastomer), 1.36mm, 1 Notch (30-028503-00) BX940 (Steel Elastomer), 1.40mm, 2 Notches (30-028504-00) BX950 (Steel Elastomer), 1.44mm, 3 Notches (30-028505-00) BX960 (Steel Elastomer), 1.48mm, 4 Notches (30-028506-00) BX970 (Steel Elastomer), 1.52mm, 5 Notches (30-028507-00) BX980 (Steel Elastomer), 1.59mm ☞-0.83mm →	DJ720▲ (21-25202-22/0)	EL890 (22-25198-01/0) GJ720▲ (20-25202-02/0)
Ducato 1.9L TD Diesel		04/98 → 04/02		95			
XUD9TF/L (DHX)	1905	4	83.00	SOHC	BX930 (Steel Elastomer), 1.36mm, 1 Notch (30-028503-00) BX940 (Steel Elastomer), 1.40mm, 2 Notches (30-028504-00) BX950 (Steel Elastomer), 1.44mm, 3 Notches (30-028505-00) BX960 (Steel Elastomer), 1.48mm, 4 Notches (30-028506-00) BX970 (Steel Elastomer), 1.52mm, 5 Notches (30-028507-00) BX980 (Steel Elastomer), 1.59mm ☞-0.83mm →	DJ720▲ (21-25202-22/0)	EL890 (22-25198-01/0) GJ720▲ (20-25202-02/0)
Ducato 2.0L		06/98 → 04/02		96			
Ducato 2.0L Panorama/Combinato		03/94 → 04/02					
XU10J2 (RFW)	1998	4	86.00	MPi, SOHC	BV140 (Fibre), 1.25mm (30-028760-00) BY320 (Fibre), 1.45mm [34]	CY081▲	ES820 (22-25198-03/0)
Ducato 2.0L		04/02 →		97			
RFL (XU10)	1998	4	86.00	MPi, SOHC	BY320 (Fibre), 1.45mm [34]	DS820▲ (21-25204-22/0)	ES820 (22-25198-03/0)
Ducato 2.0L		01/82 → 08/90		98			
XN 1T	1971	4	88.00		BM530 (Fibre), 1.40mm (30-025376-10) BN780 (Fibre), 1.60mm [34]	DM533▲ DM530■ 01/84 →	EM531 GM533■○
Ducato 2.0L		03/94 → 04/02		99			
XU10J2 (RFW)	1998	4	86.00	MPi, SOHC	BV140 (Fibre), 1.25mm (30-028760-00) BY320 (Fibre), 1.45mm [34]	CY081▲	ES820 (22-25198-03/0)











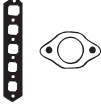

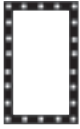

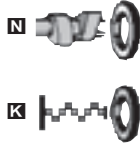























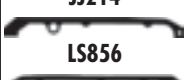













































								
HBS084  (22-15005B) M12x1.50x123mm (x10)	JC759 [60] (31-028417-00) (Steel)	JN544 (50-025202-00)	JJ283 [6] (31-025198-10) = PA349 (33-102290-10) 22x16x2mm = PB907 14x21x2mm	HR569  24-30667-00/0	NF841  35x50x8mm, FPM (50-319310-00) NB959  35x50x7mm, FPM (50-306644-50) NA5191  42x62x7mm, PTFE (50-319500-00) NA5192  90x110x7mm, PTFE (50-319501-00)	HL5010 [245]  NF836 [38]  NF826 [38]  KA611 [13]		BM530, BN780 BV140, BY320 BX930, BX940, BX950, BX960, BX970, BX980 JB841 JC415 JC759 JD520 JE647 JN244 JN544 JN547 JP043 JJ283
HBS088  (22-15014B) M12x1.50x145mm (x10) HBS277  (22-53018B) M12x1.50x148mm (x10)	JC759 [60] (31-028417-00) (Steel)	JN544 (50-025202-00)		HR569  24-30667-00/0	NF841  35x50x8mm, FPM (50-319310-00) NB959  35x50x7mm, FPM (50-306644-50) NA5191  42x62x7mm, PTFE (50-319500-00) NA5192  90x110x7mm, PTFE (50-319501-00)	HL5010 [245] 		
HBS084  (22-15005B) M12x1.50x123mm (x10)		JN547 (50-025204-10) JP043 (50-028759-00)	JJ283 [6] (31-025198-10) (Steel) = PA349 (33-102290-10) 22x16x2mm = PB907 14x21x2mm		NF817  36x50x7mm, FPM (50-319112-00) NA5191  42x62x7mm, PTFE (50-319500-00) NA5192  90x110x7mm, PTFE (50-319501-00)	HL5019 [245]  NF824 [38]  NF836 [38]  NF825 [38]  NF826 [38]  KA611 [13]		
HBS245  (22-53008B) M12x1.50x125mm (x10)	JC415  (31-025205-20) JD520 	JN547 (50-025204-10)	JJ283 [6] (31-025198-10)		NF817  36x50x7mm, FPM (50-319112-00) NA5191  42x62x7mm, PTFE (50-319500-00) NA5192  90x110x7mm, PTFE (50-319501-00)	HL5019 [245]  NF836 [38]  NF826 [38] 		
HBS086  M11x1.50x179mm (x10) 06/85→04/89 HBS038  (22-15003B) M11x1.50x175mm (x10) 04/89→	JB841  (31-018363-10)  JE647 [47] (31-022193-10)	JN244	= PA349 (33-102290-10) 22x16x2mm	HR569  24-30667-00/0	NA5191  42x62x7mm, PTFE (50-319500-00)	HL472 [37]  HR574 [37]  NF369 [38]		
HBS084  (22-15005B) M12x1.50x123mm (x10)		JN547 (50-025204-10) JP043 (50-028759-00)	JJ283 [6] (31-025198-10) = PA349 (33-102290-10) 22x16x2mm = PB907 14x21x2mm		NF817  36x50x7mm, FPM (50-319112-00) NA5191  42x62x7mm, PTFE (50-319500-00) NA5192  90x110x7mm, PTFE (50-319501-00)	HL5019 [245]  NF825 [38] NF824 [38]  NF836 [38]  NF826 [38] 		



KW/PS



Ducato 2.0L JTD Diesel		10/01 → 04/02		100	AC5011 (MLS), 1.30mm, 1 Hole [30-029478-00] → 0.47 → 0.605mm AC5020 (MLS), 1.35mm, 2 Holes [30-029478-00] [30-029478-00] → 0.605 → 0.655mm AC5031 (MLS), 1.40mm, 3 Holes [30-029479-10] [30-029479-10] → 0.655 → 0.705mm AC5040 (MLS), 1.45mm, 4 Holes [30-029480-00] [30-029480-00] → 0.705 → 0.755mm AC5051 (MLS), 1.50mm, 5 Holes [30-029481-10] [30-029481-10] → 0.755 → 0.83mm		CC5010▲ (21-29484-20/0)	EA5830
DW10 (RHV)	1998	4	85.00	Common Rail	81/110			
Ducato 2.3L JTD Diesel		04/02 →		101	AB5720 (MLS), 1.10mm [30-029317-00] AB5730 (MLS), 1.20mm [30-029318-00] AB5740 (MLS), 1.30mm [30-029319-00]		CB5720▲■ (21-29319-20/0)	FB5720▲■ (20-29319-00/0) FB5721▲■ (20-29319-01/0)
F1AE0481C	2286	4	88.00	Common Rail	81/110			
Ducato 2.4L D Diesel		01/82 → 08/90		102	BE580 (Fibre), 1.35mm [30-024116-10]		DE588▲ [109] (21-26037-23/0)	FY291▲ [12] (20-27426-00/0)
8144.61	2445	4	93.00		53/72			
Ducato 2.4L D Diesel		06/78 → 12/86		103	BE580 (Fibre), 1.35mm [30-024116-10]		DE588▲ [109] (21-26037-23/0)	FY291▲ [12] (20-27426-00/0)
Sofim-8144.61.200	2445	4	93.00		53/72			
Ducato 2.4L TD Diesel		01/89 →		104	BE580 (Fibre), 1.35mm [30-024116-10]		DR073▲	FB5102▲ [12] (20-27140-02/0)
Ducato 2.4L TD 4x4 Diesel		01/89 →						
8142.61	2445	4	93.00		53/72			
Ducato 2.4L TD id Maxi Diesel		01/85 →		105	BR070 (Fibre), 1.20mm [30-025645-10] → 12/89		DS381▲ [111] (21-27141-20/0)	FB5100▲ [12] (20-27140-00/0)
8144.21	2445	4	93.00	Sofim, Turbo	68/92			
Ducato 2.4 TD Panorama Diesel		01/86 → 08/90		106	BR070 (Fibre), 1.20mm [30-025645-10]		DS381▲ [111] (21-27141-20/0)	FB5100▲ [12] (20-27140-00/0)
8144.21.220	2445	4	93.00	Direct Injection, SOHC, Turbo	68/92			
Ducato 2.5L D Diesel		01/82 → 03/94		107	BG450 (Fibre), 1.35mm [30-025842-10] AY290 (Fibre), 1.60mm [112] [30-027426-00] AY300 (Fibre), 1.70mm [112] [30-026654-20] AY310 (Fibre), 1.80mm [112] [30-026655-20]		DE588▲ [109] (21-26037-23/0)	FY291▲ [12] (20-27426-00/0)
Ducato 2.5L D 4x4 Diesel		01/87 → 03/94						
CRD93L (U25-661)	2500	4	93.00		54-55/ 73-75			
8144.67	2500	4	93.00	Indirect Injection, SOHC	55/75			

								
HBS261  (22-53014B) M12x1.50x131mm (x10)					HR5046 	NA5035 27x47x7mm, FPM (50-319474-00) NA5191  42x62x7mm, PTFE (50-319500-00) NA5192  90x110x7mm, PTFE (50-319501-00)	HL5016 [245] 	 AB5720, AB5730, AB5740  AC5020, AC5040  AY290, AY300, AY310  BE580  BG450  BR070  JC054  JC055  JC706  JC707  JD5338  JM5201  JM5202  JN462  JN594  JJ100  JJ214  JS856  JS857
HBS251  (22-17020B) M14x1.50x193mm (x6) M11x1.50x133mm (x4)	JD5338  (31-029922-00) JD5337  (31-029921-00)	JM5201 [165] (50-029918-00) (Rubber/Metal) →08/04 JM5202 [165] (50-029919-00) (Rubber) 08/04→	JH5077 (50-029920-00) JH5081 (31-029964-00)		NA5201 34x60x10mm, FPM (50-319509-00)	KD931 [72][73] KK5598 [72][73]		
HBS011  (22-51004B) M12x1.25x160mm (x10) M12x1.25x119mm (x12)	JC054  (x4) (31-024274-10) JC055  (x4) (31-025031-10)	JN462 (50-024272-00) →Eng.574798 JN594 [71] (50-026037-00)	JJ100 LS856  (50-025627-00) LS857  (50-025628-00)	HR602  24-30670-61/0	NP067  50x70x10mm, FPM (50-307111-70) NP068  55x70x8mm, FPM (50-303186-00) NA5055  70x90x10mm, FPM	KA546 [13] KL221 [11] LS859 [11]  LS858 [11] 		
HBS011  (22-51004B) M12x1.25x160mm (x10) M12x1.25x119mm (x12)	JC054  (31-024274-10) JC055  (31-025031-10)	JN462 (50-024272-00) →Eng.574798 JN594 [71] (50-026037-00) Eng.574799→	JJ100 LS856 (50-025627-00) LS857 (50-025628-00)	HR602  24-30670-61/0	NP068 55x70x8mm, FPM (50-303186-00) NP067  50x70x10mm, FPM (50-307111-70) NA5055  70x90x10mm, FPM	KA546 [13] KL221 [11] LS858 [11] LS859 [11]		
HBS011  (22-51004B) M12x1.25x160mm (x10) M12x1.25x119mm (x12)	JC054  (31-024274-10) JC055  (31-025031-10)	JN462 (50-024272-00) →Eng.574798 JN594 [71] (50-026037-00) Eng.574799→	JJ214 LS856 (50-025627-00) LS857 (50-025628-00)	HR662 	NP067  50x70x10mm, FPM (50-307111-70) NP068  55x70x8mm, FPM (50-303186-00) NA5055  70x90x10mm, FPM	KA292 [13] KA546 [13] HJ271 [39]  KD929 [72][73] LS858 [11]		
HBS011  (22-51004B) M12x1.25x160mm (x10) M12x1.25x119mm (x12)	JC054  (31-024274-10) JC706  (x3) JC707  (31-026039-00)	JN594 [71] (50-026037-00)	JJ100 LS856 (50-025627-00) LS857 (50-025628-00)	HR602  24-30670-61/0 HR781 	NP067  50x70x10mm, FPM (50-307111-70) NP068  55x70x8mm, FPM (50-303186-00) NA5055  70x90x10mm, FPM	LS858 [11] LS859 [11]		
HBS011  (22-51004B) M12x1.25x160mm (x10) M12x1.25x119mm (x12)	JC054  (31-024274-10) JC706  JC707  (31-026039-00)	JN594 [71] (50-026037-00)	JJ100 LS856 (50-025627-00) LS857 (50-025628-00)	HR602  24-30670-61/0 HR781 	NP067  50x70x10mm, FPM (50-307111-70) NP068  55x70x8mm, FPM (50-303186-00) NF833 (50-305860-50) NA5055  70x90x10mm, FPM	LS858 [11] LS859 [11]		
HBS011  (22-51004B) M12x1.25x160mm (x10) M12x1.25x119mm (x12)	JC054  (x4) (31-024274-10) JC055  (x4) (31-025031-10)	JN462 (50-024272-00) →Eng.574798 JN594 [71] (50-026037-00)	JJ100 LS856  (50-025627-00) LS857  (50-025628-00)	HR602  24-30670-61/0 HR782 	NP067  50x70x10mm, FPM (50-307111-70) NP068  55x70x8mm, FPM (50-303186-00) NF833 (50-305860-50) NP068  55x70x8mm, FPM (50-303186-00)			

FIAT



KW/PS



Ducato 2.5L D Diesel		01/94 → 06/96		108		AY290 (Fibre), 1.60mm [112] (30-027426-00) AY300 (Fibre), 1.70mm [112] (30-026654-20) AY310 (Fibre), 1.80mm [112] (30-026655-20)		DS381▲ [111] (21-27141-20/0)		FB5101▲ [167] (20-27140-01/0)	
8140.67.X230	2499	4	93.00	Sofim	63/85						
Ducato 2.5L D Diesel		03/94 → 04/02		109		AY290 (Fibre), 1.60mm [112] (30-027426-00)		DS381▲ [111] (21-27141-20/0)		FB5101▲ [167] (20-27140-01/0)	
Ducato 2.5L D 4x4 Diesel		03/94 → 04/02									
Ducato 2.5L D Combinato Diesel		08/94 → 04/02									
8140.67	2500	4	93.00	Indirect Injection	55/75	AY300 (Fibre), 1.70mm [112] (30-026654-20) AY310 (Fibre), 1.80mm [112] (30-026655-20)					
Ducato 2.5L D Maxi Diesel		01/94 → 06/96		110		AY290 (Fibre), 1.60mm [112] (30-027426-00) AY300 (Fibre), 1.70mm [112] (30-026654-20) AY310 (Fibre), 1.80mm [112] (30-026655-20)		DS381▲ [111] (21-27141-20/0)		FB5101▲ [167] (20-27140-01/0)	
8140.67	2500	4	93.00	Indirect Injection, Turbo	55/75						
8144.67	2500	4	93.00	Indirect Injection, SOHC, Turbo	55/75						
Ducato 2.5L TD Diesel		07/90 → 03/94		111		AB5100 (Fibre), 1.20mm [112] (30-027140-10) AY580 (Fibre), 1.30mm [112] (30-027141-10) AY590 (Fibre), 1.40mm [112] (30-027892-10) AB5110 (Fibre), 1.50mm (30-027147-10)		DS381▲ [111] (21-27141-20/0) Eng.1050634 →		FB5100▲ [12] (20-27140-00/0) FB5102▲ [12] (20-27140-02/0)	
8140.27	2500	4	93.00		70/95						
Ducato 2.5L TD Diesel		01/86 → 08/90		112		BR070 (Fibre), 1.20mm (30-025645-10) →12/89		DS381▲ [111] (21-27141-20/0)		FB5100▲ [12] (20-27140-00/0)	
Ducato 2.5L TD 4x4 Diesel		01/86 → 08/90									
8144.21	2445	4	93.00		68/92						
Ducato 2.5L TD 4x4 Diesel		07/90 → 03/94		113		AB5100 (Fibre), 1.20mm [112] (30-027140-10) AY580 (Fibre), 1.30mm [112] (30-027141-10) AY590 (Fibre), 1.40mm [112] (30-027892-10) AB5110 (Fibre), 1.50mm (30-027147-10)		DR073▲		FB5102▲ [12] (20-27140-02/0)	
8140.27	2500	4	93.00		70/95						











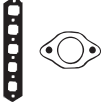

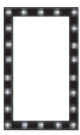

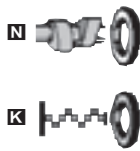

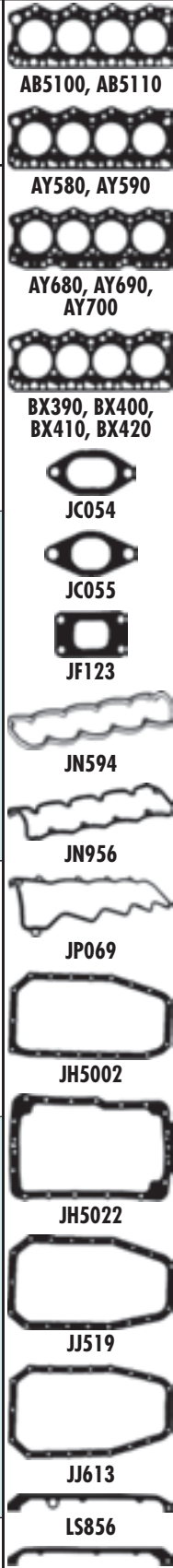



































HBS011 (22-51004B) M12x1.25x160mm (x10) M12x1.25x119mm (x12)	JC054 (31-024274-10) JC055 (31-025031-10)	JN956	JH5002 LS856 (50-025627-00) LS857 (50-025628-00)	HR602 24-30670-61/0 HR781	NP067 50x70x10mm, FPM (50-307111-70) NP068 55x70x8mm, FPM (50-303186-00) NA5055 70x90x10mm, FPM NF883 [3] 114x171x13mm, FPM (50-307265-70) NF886 [3] 100x120x16mm, FPM (50-307086-70)	JR580 [11] LS859 [11]	AB5100, AB5110 AY290, AY300, AY310 AY580, AY590, BR070 JC054 JC055 JC706 JC707 JF123 JN462 JN594 JN596 JN956 JH5002 JJ100 JJ214 JJ519 LS856		
HBS011 (22-51004B) M12x1.25x160mm (x10) M12x1.25x119mm (x12)	JC054 (31-024274-10) JC055 (31-025031-10)	JN462 (50-024272-00) →Eng.574798 JN596 (50-023671-00) JN594 [71] (50-026037-00) Eng.574799→	JH5002	HR602 24-30670-61/0	NP067 50x70x10mm, FPM (50-307111-70) NP068 55x70x8mm, FPM (50-303186-00) NF833 (50-305860-50) NF883 [3] 114x171x13mm, FPM (50-307265-70) NF886 [3] 100x120x16mm, FPM (50-307086-70)				
HBS011 (22-51004B) M12x1.25x160mm (x10) M12x1.25x119mm (x12)	JC054 (31-024274-10) JC055 (31-025031-10)	JN956	JH5002	HR602 24-30670-61/0	NP067 50x70x10mm, FPM (50-307111-70) NP068 55x70x8mm, FPM (50-303186-00) NA5055 70x90x10mm, FPM NF883 [3] 114x171x13mm, FPM (50-307265-70) NF886 [3] 100x120x16mm, FPM (50-307086-70)				
HBS011 (22-51004B) M12x1.25x160mm (x10) M12x1.25x119mm (x12)	JC054 (31-024274-10) JC055 (31-025031-10) JF123 (31-027523-00)	JN956 JN594 [71] (50-026037-00) Eng.574799→	JJ519 (31-025623-00) LS856 (50-025627-00) LS857 (50-025628-00)	HR602 24-30670-61/0 HR781	NP067 50x70x10mm, FPM (50-307111-70) NP068 55x70x8mm, FPM (50-303186-00) NA5055 70x90x10mm, FPM NF883 100x118x10mm, FPM (50-307096-70)	HJ271 [39] KD929 [72][73] JR580 [11] →Eng.2921820 LC281 [11] LC282 [11] LS858 [11] LS859 [11] KK5599 [45] KV927 [46]			
HBS011 (22-51004B) M12x1.25x160mm (x10) M12x1.25x119mm (x12)	JC054 (31-024274-10) JC706 (x3) JC707 (31-026039-00)	JN594 [71] (50-026037-00)	JJ100 LS856 (50-025627-00) LS857 (50-025628-00)	HR602 24-30670-61/0 HR781	NP067 50x70x10mm, FPM (50-307111-70) NP068 55x70x8mm, FPM (50-303186-00) NF833 (50-305860-50) NA5055 70x90x10mm, FPM	LS858 [11] LS859 [11]			
HBS011 (22-51004B) M12x1.25x160mm (x10) M12x1.25x119mm (x12)		JN594 [71] (50-026037-00)	JJ214	HR602 24-30670-61/0 HR781	NP067 50x70x10mm, FPM (50-307111-70) NP068 55x70x8mm, FPM (50-303186-00) NA5055 70x90x10mm, FPM	LC281 [11] LC282 [11]			

FIAT



KW/PS



								
HBS011  (22-51004B) M12x1.25x160mm (x10) M12x1.25x119mm (x12)	JC054  (31-024274-10) JC055  (31-025031-10)	JN594 [71] (50-026037-00) JN956	JJ519 (31-025623-00) LS856 (50-025627-00) LS857 (50-025628-00)	HR602  24-30670-61/0 HR781 	NP067  50x70x10mm, FPM (50-307111-70) NP068  55x70x8mm, FPM (50-303186-00) NA5055  70x90x10mm, FPM NF886  [3] 100x120x16mm, FPM (50-307086-70) NF883  [3] 114x171x13mm, FPM (50-307265-70)	KD929 [72][73] KD931 [72][73] JR580 [11] →09/99 →Eng.2921820 LC280 [11] LC281 [11] LC282 [11] LS859 [11] KK5599 [45] Eng.2921820→ KV927 [46]	AB5100, AB5110 AY580, AY590 AY680, AY690, AY700 BX390, BX400, BX410, BX420 JC054 JC055 JF123 JN594 JN956 JP069 JH5002 JJ519 JJ613 LS856 LS857	
HBS011  (22-51004B) M12x1.25x160mm (x10) M12x1.25x119mm (x12)	JC054  (31-024274-10) JC055  (31-025031-10)	JN594 [71] (50-026037-00) JN956	JJ519 (31-025623-00) LS856 (50-025627-00) LS857 (50-025628-00)	HR602  24-30670-61/0 HR781 	NP067  50x70x10mm, FPM (50-307111-70) NP068  55x70x8mm, FPM (50-303186-00) NA5055  70x90x10mm, FPM NF883  [3] 114x171x13mm, FPM (50-307265-70) NF886  [3] 100x120x16mm, FPM (50-307086-70)	KD929 [72][73] KD931 [72][73] JR580 [11] →09/99 →Eng.2921820 LC280 [11] LC281 [11] LC282 [11] LS859 [11] KK5599 [45] Eng.2921820→ KV927 [46]	JC054 JC055 JF123 JN594 JN956 JP069 JH5002 JJ519 JJ613 LS856 LS857	
HBS255  (22-17021B) M12x1.25x90mm (x8) M12x1.25x160mm (x14)	JC054  (x4) (31-024274-10) JC055  (x4) (31-025031-10)	JP069	JH5022 (50-029271-00) JJ519 (31-025623-00)	HR602  24-30670-61/0	NP067  50x70x10mm, FPM (50-307111-70) NF885  [3] 70x159x16mm, FPM (50-307266-70) NF883  [3] 114x171x13mm, FPM (50-307265-70)	JR580 [11] →09/99 →Eng.2921820 LC281 [11] Rubber LC282 [11] LS859 [11]  LS858 [11]  KV927 [46]	JH5002 JJ519 JJ613 LS856 LS857	
HBS255  (22-17021B) M12x1.25x90mm (x8) M12x1.25x160mm (x14)	JC054  (31-024274-10) JC055  (31-025031-10) JF123  (31-027523-00)	JP069	JJ613	HR602  24-30670-61/0	NF885  [3] 70x159x16mm, FPM (50-307266-70) NF883  [3] 114x171x13mm, FPM (50-307265-70)	KD929 [72][73] KD931 [72][73] Steel KD932 [72][73] Steel JR580 [11] LC280 [11] LC281 [11] Rubber LC282 [11] KK5599 [45] KV927 [46]	JH5002 JJ519 JJ613 LS856 LS857	
HBS255  (22-17021B) M12x1.25x90mm (x8) M12x1.25x160mm (x14)	JC054  (x4) (31-024274-10) JC055  (x4) (31-025031-10) JF123  (31-027523-00)	JP069	JH5002	HR602  24-30670-61/0	NP067  50x70x10mm, FPM (50-307111-70) NP068  55x70x8mm, FPM (50-303186-00) NF885  [3] 70x159x16mm, FPM (50-307266-70) NF883  [3] 114x171x13mm, FPM (50-307265-70)	HL5032 [245]  KD929 [72][73] KD931 [72][73] Steel KD932 [72][73] Steel JR580 [11] LC280 [11] LC281 [11] Rubber LC282 [11]	JH5002 JJ519 JJ613 LS856 LS857	

FIAT



KW/PS

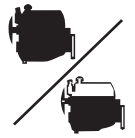

Ducato 2.8L JTD Power Diesel		05/04 →		119			
8140.43N	2798	4	94.40	Direct Injection			
Ducato 2.8L TD 4x4 Diesel		05/98 →11/01		120	AY680 (Fibre), 1.60mm (30-028607-00) AY690 (Fibre), 1.70mm (30-028608-00) AY700 (Fibre), 1.80mm (30-028609-00)		
8140.63	2798	4	94.40	Direct Injection, SOHC	64/87		
Ducato 2.8L TDI Diesel		10/97 →04/02		121	BX390 (Fibre), 1.20mm [71] (30-027867-00) BX400 (Fibre), 1.30mm [71] (30-027868-00) BX410 (Fibre), 1.40mm [71] (30-027883-00) BX420 (Fibre), 1.50mm [71] (30-027884-00)	DX391▲ (21-27867-21/0)	GX410▲ (20-27867-03/0)
8140.43	2800	4	94.40	Direct Injection	90/122		
Ducato 2.8L TDI Diesel		10/97 →04/02		122	BX390 (Fibre), 1.20mm [71] (30-027867-00) BX400 (Fibre), 1.30mm [71] (30-027868-00) BX410 (Fibre), 1.40mm [71] (30-027883-00) BX420 (Fibre), 1.50mm [71] (30-027884-00)	DX391▲ (21-27867-21/0)	GX390▲ (20-27867-00/0)
8140.43	2800	4	94.40	Direct Injection	90/122		
Ducato 2.8L TDI 4x4 Diesel		06/99 →04/02		123	BX390 (Fibre), 1.20mm [71] (30-027867-00) BX400 (Fibre), 1.30mm [71] (30-027868-00) BX410 (Fibre), 1.40mm [71] (30-027883-00) BX420 (Fibre), 1.50mm [71] (30-027884-00)	DX390▲■ (21-27867-20/0)	GX391▲ (20-27867-01/0)
8140.43	2800	4	94.40	Direct Injection	90/122		
Duna 1.1L 60		01/87 →12/91		124	BP290 (Fibre) (30-025345-10)	DP293 (21-25345-22/0)	GK590 (20-25345-02/0)
146 A6.000	1116	4	76.00		40/54		
Duna 1.3L 70		01/87 →12/91		125	BP290 (Fibre) (30-025345-10)	DP293 (21-25345-22/0)	GK590 (20-25345-02/0)
146 A5.000	1301	4	76.10		49/53/ 67/72		











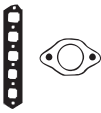

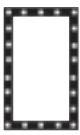

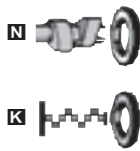































							AY680, AY690, AY700 JJ613
HBS255 (22-17021B) M12x1.25x90mm (x8) M12x1.25x160mm (x14)							BP290 BX390, BX400, BX410, BX420 JC054 JC055 JD5155 JF123
HBS011 (22-51004B) M12x1.25x160mm (x10) M12x1.25x119mm (x12) HBS255 (22-17021B) M12x1.25x90mm (x8) M12x1.25x160mm (x14)	JC054 (31-024274-10) JC055 (31-025031-10)	JN956	JH5002 JJ519 (31-025623-00) JH5022 (50-029271-00) 05/99→	HR602 24-30670-61/0	NP067 50x70x10mm, FPM (50-307111-70) NP068 55x70x8mm, FPM (50-303186-00) NF885 [3] 70x159x16mm, FPM (50-307266-70) NF883 [3] 114x171x13mm, FPM (50-307265-70)	HL5032 [245] KD932 [72] [73] JR580 [11] →09/99 →Eng.2921820	HL5032 KD932 JR580 JD5155 JF123
HBS255 (22-17021B) M12x1.25x90mm (x8) M12x1.25x160mm (x14)	JC054 (31-024274-10) JC055 (31-025031-10) JF123 (31-027523-00)	JN956	JJ613	HR602 24-30670-61/0	NP067 50x70x10mm, FPM (50-307111-70) NP068 55x70x8mm, FPM (50-303186-00) NF885 [3] 70x159x16mm, FPM (50-307266-70) NF883 [3] 114x171x13mm, FPM (50-307265-70)	HL5032 [245] KD929 [72] [73] KD931 [72] [73] KD932 [72] [73] Steel JR580 [11] LC280 [11] LC281 [11] Rubber LC282 [11] KK5599 [45] KV927 [46]	JN283 JN594 JN956
HBS255 (22-17021B) M12x1.25x90mm (x8) M12x1.25x160mm (x14)	JC054 (31-024274-10) JC055 (31-025031-10) JF123 (31-027523-00)	JN594 [71] (50-026037-00)	JJ214	HR602 24-30670-61/0	NP067 50x70x10mm, FPM (50-307111-70) NP068 55x70x8mm, FPM (50-303186-00) NF885 [3] 70x159x16mm, FPM (50-307266-70) NF883 [3] 114x171x13mm, FPM (50-307265-70)	HL5032 [245] KD929 [72] [73] KD931 [72] [73] Steel KD932 [72] [73] Steel JR580 [11] LC280 [11] LC281 [11] Rubber LC282 [11] KK5599 [45] KV927 [46]	JH5002 JH5022 JJ078
HBS098 (22-17011B) M12x1.25x140mm (x5) M10x1.25x116mm (x5)	JD5155 (31-029308-00)	JN283	JJ078	HR596	NA5187 (x2) 30x52x7mm, ACM (50-319492-00) NB818 40x56x7mm, ACM NB730 70x85x8mm, FPM	LS496 [70] KA294 [13]	JJ214
HBS051 (22-17001B) M10x1.25x98mm (x5) M10x1.25x84mm (x5)	JD5155 (31-029308-00)	JN283	JJ078	HR596	NA5187 (x2) 30x52x7mm, ACM (50-319492-00) NB818 40x56x7mm, ACM NB730 70x85x8mm, FPM	KA294 [13] KH029 [53] LA163 [53] JR556 [11]	JJ519

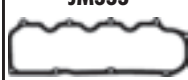

KW/PS



Duna 1.7L DS Diesel				01/87 → 12/91	126	BT220 (Fibre), 1.65mm (30-025166-10) BT230 (Fibre), 1.80mm, 1 Notch BT240 (Fibre), 1.95mm, 2 Notches (30-025168-10)		DV680▲ (21-25142-26/0)	EV684 (22-25142-00/0) GV680▲ [100]
149 B3.000	1697	4	82.60	SOHC	42/57				
Elba 1.3L D Diesel				04/86 → 10/92	127	BP290 (Fibre) (30-025345-10) BJ860 (Fibre), 1.65mm (30-026451-10) BJ870 (Fibre), 1.80mm, 1 Notch (30-026452-10) BJ880 (Fibre), 1.95mm, 2 Notches (30-026453-10)		DJ872▲ (21-25319-21/0)	GJ872▲
127 A5.000	1301	4	76.00		33/44				
Elba 1.6L				04/89 → 12/93	128	BT410 (Fibre)		DT446 (21-26647-23/0) 159 B9.000	GT446 [12] (20-26647-03/0)
159 A3.000	1581	4	86.40	Carburettor, SOHC	63/86				
Fiorino Van 900				10/77 → 12/84	129	BP520 (Fibre), 1.20mm (30-026522-20) BP030 (Fibre), 1.80mm (30-025210-20)		CG01A▲ → Eng.8064870 DP011■ [153] (21-26522-20/0) → Eng.8064870 DR610 [154] → Eng.8064870	GP011 → Eng.8064870
100 GL.000	903	4	65.00		34/46				
Fiorino 1.0L				01/77 → 12/83	130	BP060 (Fibre), 1.20mm (30-024118-40)		DP060 (21-24118-23/0)	GP060
147A5.000	1048	4	76.00		51/69				
Fiorino Van 1.0L				01/80 → 12/87	131	BP520 (Fibre), 1.20mm (30-026522-20) BP030 (Fibre), 1.80mm (30-025210-20)		CG01A▲ → Eng.8064870 DP011■ [153] (21-26522-20/0) → Eng.8064870 DR610 [154] → Eng.8064870	GP011 → Eng.8064870
Fiorino Van 1050				01/80 → 12/87					
127 A.000	903	4	65.00	OHV	34/46				
Fiorino Van 1.1L 60				11/86 → 12/93	132	BP290 (Fibre) (30-025345-10)		DP293 (21-25345-22/0)	GK590 (20-25345-02/0)
146 A9.000	1116	4	76.00	SOHC	40/54				
Fiorino 1.3L				01/88 → 12/94	133	BP290 (Fibre) (30-025345-10)		DP293 (21-25345-22/0)	GK590 (20-25345-02/0)
Fiorino Van 1.3L 70				01/88 → 12/94					
146 A5.000	1301	4	76.10		49/53/ 67/72				
Fiorino 1.3L D Diesel				05/84 → 12/88	134	BJ860 (Fibre), 1.65mm (30-026451-10) BJ870 (Fibre), 1.80mm, 1 Notch (30-026452-10) BJ880 (Fibre), 1.95mm, 2 Notches (30-026453-10)		DJ872▲ (21-25319-21/0)	GJ872▲
127 A5.000	1301	4	76.00		33/44				

								 BJ860, BJ870, BJ880	 JJ398
HBS095  (22-17007B) M12x1.25x133mm (x10)	JC738 (31-026290-10)	JN459 (31-025142-10)	JJ298 (Cork) (Rubber) JJ398 (31-027379-00)	HR596 	NA5187 30x52x7mm, ACM (50-319492-00) NB742 30x43x8mm, ACM (50-319408-00) NB732 74x90x10mm, FPM NA5062 74x90x10mm, ACM	KA556 [13] LT021 [13] [164] LT023 [13] LV583 [53] KT465 [54] LT019 [86] KT639 [11] LV589 [11] LT498 [45] LV582 [45] LV585 [45]		 BP060	 JJ440
	JD5155 (31-029308-00)	JN417 JN669 (31-025319-00) (Cork)	JJ078 JJ440 (31-027495-00)	HR596 	NA5187 30x52x7mm, ACM (50-319492-00) NA5051 40x56x7mm, FPM NA5052 70x85x8mm, FPM	KA294 [13] KH029 [53] LA163 [53] LS488 [53] HJ274 [39]  KD717 [91] JR556 [11] KV365 [155]		 BT220, BT230, BT240	
HBS051  (22-17001B) M10x1.25x98mm (x5) M10x1.25x84mm (x5)						KA294 [13]		 BT410	
HBS109  (22-17009B) M9x1.25x60mm (x1) M9x1.25x95mm (x9)	JC973  (31-021833-10)	JM333 (31-021029-00)	HC027  (23-17373-01/0)	HR599  (24-31919-10/0)	NB633 42x63x7mm, ACM (50-319184-00) NA5049 64x80x8mm, ACM NB808 64x80x8mm, FPM	KD226 [91] KD747 [91] JR154 [11] JR556 [11] KT600 [11] KT446 [46] KT753 [46]		 JC738	
	JD5155 (31-029308-00)  JE729	JN283	JJ078	HR596 	NA5187 30x52x7mm, ACM (50-319492-00) NB818 40x56x7mm, ACM NA5049 64x80x8mm, ACM	KA294 [13] LS492 [11] KT446 [46]		 JC973	
HBS109  (22-17009B) M9x1.25x60mm (x1) M9x1.25x95mm (x9)	JC973  (31-021833-10)	JM333 (31-021029-00)	HC027  (23-17373-01/0)	HR599  (24-31919-10/0)	NB633 42x63x7mm, ACM (50-319184-00) NB808 64x80x8mm, FPM NA5049 64x80x8mm, ACM	KD226 [91] KD747 [91] JR154 [11] JR556 [11] KT600 [11] KT446 [46] KT753 [46]		 JD5155	
HBS051  (22-17001B) M10x1.25x98mm (x5) M10x1.25x84mm (x5) HBS098  (22-17011B) M12x1.25x140mm (x5) M10x1.25x116mm (x5)	JD5155 (31-029308-00)	JN283	JJ078	HR596 	NA5187 (x2) 30x52x7mm, ACM (50-319492-00) NB818 40x56x7mm, ACM NB730 70x85x8mm, FPM	LS496 [70] KA294 [13] HJ279 [39] [48] 		 JE729	
HBS098  (22-17011B) M12x1.25x140mm (x5) M10x1.25x116mm (x5)	JD5155 (31-029308-00)	JN283	JJ078	HR596 	NA5187 (x2) 30x52x7mm, ACM (50-319492-00) NB818 40x56x7mm, ACM NB730 70x85x8mm, FPM	LS496 [70] KA294 [13] HJ279 [39] [48] 		 JM333	
	JD5155 (31-029308-00)	JN417 JN669 (31-025319-00) (Cork) (Rubber)	JJ078 JJ440 (31-027495-00)	HR596 	NA5187 30x52x7mm, ACM (50-319492-00) NA5051 40x56x7mm, FPM NA5052 70x85x8mm, FPM	KA294 [13] HJ274 [39] 		 JN283	
								 JN417	
								 JN459	
								 JN669	
								 HC027	
								 JJ078	
								 JJ298	











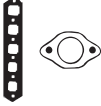

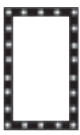

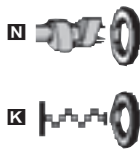

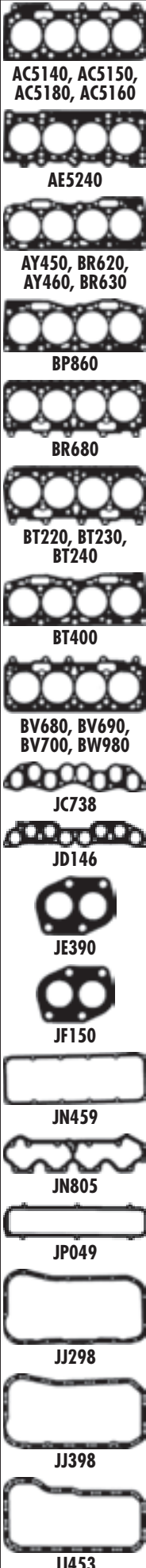



















































FIAT



KWPS



Fiorino 1.3L D Multijet Diesel 02/08 → 135						CD5810▲	ED5810 FD5810
199 A2.000	1248	4	69.60	Direct Injection, DOHC	55/75		
Fiorino 1.4L 05/94 → 05/01 136					AY450 (Fibre) [249] BR620 (Fibre) [249] (30-027865-00)	DR620 (21-26295-21/0)	GR620
146 D5.000	1372	4	80.50	SOHC	49/67		
Fiorino Van 1.4L i.e. 70 05/94 → 05/01 137					AY450 (Fibre) [249] BR620 (Fibre) [249] (30-027865-00) BT400 (Fibre) (30-026693-10)	DR620 (21-26295-21/0)	GR620
146 C5.000/146 D5.000	1372	4	80.50	SOHC	49/67		
Fiorino Van 1.5L 01/88 → 08/93 138					BP860 (Fibre) (30-025893-10) Eng.5750056 →	DJ851▲ Eng.5750056 → DP861 (21-25893-22/0) Eng.5750056 →	GP861 (20-25893-02/0)
Fiorino Van 1.5L i.e. 75 05/88 → 12/93					55/75		
149 C1.000	1498	4	86.40	SOHC	55/75		
Fiorino 1.6L 01/94 → 05/01 139							
Fiorino 1.6L i.e. 75 10/93 → 05/01							
146 C6.000	1581	4	86.40	SOHC	55/75		
146 D6.000	1585	4	86.40	SOHC	55/75		
Fiorino 1.6L B 10/93 → 140					AY460 (Fibre) [249] BR630 (Fibre) (30-027866-00)	DR630 (21-26294-21/0)	GR630 (20-26294-01/0)
Fiorino Van 1.6L i.e. 75 10/93 →					55/75		
220 A 2.000	1581	4	86.40	EFi, SOHC	55/75		
Fiorino 1.7L D Diesel 05/88 → 10/99 141					BT220 (Fibre), 1.65mm (30-025166-10) AC5140 (MLS), 1.66mm (30-026296-20) AC5150 (MLS), 1.76mm (30-026297-20) BT230 (Fibre), 1.80mm, 1 Notch AC5180 (MLS), 1.86mm (30-027859-20) BT240 (Fibre), 1.95mm, 2 Notches (30-025168-10) AC5160 (MLS), 1.96mm (30-026298-20)	DV680▲ (21-25142-26/0)	EV684 (22-25142-00/0) GV680▲ [100]
Fiorino Van 1.7L D Diesel 12/87 → 12/90					42/57		
Fiorino Van 1.7L D 60 Diesel 05/88 → 05/00							
149 B3.000	1697	4	82.60	SOHC	42/57		
Fiorino 1.7L D Diesel 01/88 → 10/99 142					BT220 (Fibre), 1.65mm (30-025166-10) BT230 (Fibre), 1.80mm, 1 Notch BT240 (Fibre), 1.95mm, 2 Notches (30-025168-10)	DV680▲ (21-25142-26/0)	EV684 (22-25142-00/0) GV680▲ [100]
Fiorino Van 1.7L D 60 Diesel 05/88 → 10/96					46/63		
146 B2.000	1697	4	82.60				
Fiorino 1.7L TD Diesel 01/97 → 05/01 143					BR680 (Graphite), 1.65mm BV680 (Fibre), 1.67mm, 0 Notches (30-026296-10) BV690 (Fibre), 1.75mm, 1 Notch BV700 (Fibre), 1.85mm, 2 Notches (30-027859-00) BW980 (Fibre), 1.93mm, 3 Notches	DV680▲ (21-25142-26/0)	EV684 (22-25142-00/0) GV680▲ [100]
Fiorino Van 1.7L TD 65 Diesel 01/97 → 05/01					46/63		
146 D7.000	1697	4	82.60				
Grande Punto 1.2L 10/05 → 144					AE5240 (MLS) (30-029844-00)	CE5242	
199 A4.000	1242	4	70.80	Injection, DOHC			
Grande Punto 1.3L D Multijet Diesel 10/05 → 145						CD5810▲	ED5810 FD5810
199 A2.000	1248	4	69.60	Direct Injection, DOHC	55/75		
Grande Punto 1.3L D Multijet Diesel 10/05 → 146						CD5820▲	ED5820 FD5820▲
199 A3.000	1248	4	69.60	Direct Injection, DOHC	66/90		

								
								 AC5140, AC5150, AC5180, AC5160  AE5240  AY450, BR620, AY460, BR630  BP860  BR680  BT220, BT230, BT240  BT400  BV680, BV690, BV700, BW980  JC738  JD146  JE390  JF150  JN459  JN805  JP049  JJ298  JJ398  JJ453
HBS051  (22-17001B) M10x1.25x98mm (x5) M10x1.25x84mm (x5)		JN805 [156] (31-026819-00) JP049 (31-026820-00)	JJ453		 NA5187 (x2) 30x52x7mm, ACM (50-319492-00)  NB818 40x56x7mm, ACM			
HBS051  (22-17001B) M10x1.25x98mm (x5) M10x1.25x84mm (x5)	JD146 (31-027221-10)	JN805 [156] (31-026819-00) JP049 (31-026820-00)	JJ453	HR596 	 NA5187 (x2) 30x52x7mm, ACM (50-319492-00)  NB818 40x56x7mm, ACM	KA294 [13] KT465 [54] KT754 [11] KV122 [56]		
HBS051  (22-17001B) M10x1.25x98mm (x5) M10x1.25x84mm (x5)	JD146 (31-027221-10)  JE390  (31-021632-10)	JM654 JN805 [156] (31-026819-00) JP049 (31-026820-00)	JJ453	HR596 	 NA5187 30x52x7mm, ACM (50-319492-00)  NB818 40x56x7mm, ACM  NA5049 64x80x8mm, ACM	KA294 [13] HJ279 [39] [48] 		
HBS051  (22-17001B) M10x1.25x98mm (x5) M10x1.25x84mm (x5)						KA294 [13]		
HBS051  (22-17001B) M10x1.25x98mm (x5) M10x1.25x84mm (x5)	JD146 (31-027221-10)  JF150 (31-027151-00)	JP049 (31-026820-00)	JJ453	HR363 	 NA5187 (x2) 30x52x7mm, ACM (50-319492-00)  NB818 40x56x7mm, ACM	KA354 [13] KT465 [54]		
HBS095  (22-17007B) M12x1.25x133mm (x10)	JC738 (31-026290-10)	JN459 (31-025142-10)	JJ298 (Cork) (Rubber) JJ398 (31-027379-00)	HR596 	 NA5187 30x52x7mm, ACM (50-319492-00)  NB742 30x43x8mm, ACM (50-319408-00)  NB732 74x90x10mm, FPM  NA5062 74x90x10mm, ACM	KA556 [13] LT021 [13] [164] LT023 [13] LV583 [53] KT465 [54] LT019 [86] KT639 [11] LV589 [11] LT498 [45] LV582 [45] LV585 [45]		
HBS095  (22-17007B) M12x1.25x133mm (x10)		JN459 (31-025142-10)	JJ298 JJ398 (31-027379-00)	HR596 	 NA5187 30x52x7mm, ACM (50-319492-00)  NB742 30x43x8mm, ACM (50-319408-00)  NB732 74x90x10mm, FPM  NA5062 74x90x10mm, ACM	LT498 [45]		
HBS095  (22-17007B) M12x1.25x133mm (x10)	JC738 (31-026290-10)	JN459 (31-025142-10)	JJ298 (Cork) (Rubber) → Eng.9185 JJ398 (31-027379-00) Eng.9186→	HR596 	 NA5187 30x52x7mm, ACM (50-319492-00)  NB742 30x43x8mm, ACM (50-319408-00)  NB732 74x90x10mm, FPM  NA5062 74x90x10mm, ACM	LT019 [86] JS081 [11] KT639 [11] LT498 [45]		
HBS247  (22-17019B) M9x1.25x87mm (x10)					 NA5053 30x42x7mm, FPM (50-319488-00)			
HBS353  (22-17025B) M10x1.25x119mm (x10)								
HBS353  (22-17025B) M10x1.25x119mm (x10)								

FIAT



KW/PS

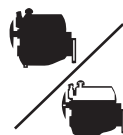

Model						Year	Power (KW/PS)	Engine Code	Notes
Grande Punto 1.4L						10/05 →	147	AG7380 (MLS) (30-030143-00)	CG7380 (21-30143-00/0) 01/05 →
350 A1.000	1368	4	72.00	Injection, SOHC		57-55/ 78-75			
Grande Punto 1.4L T-Jet						09/07 →	148		
198 A4.000	1368	4	72.00	Injection, DOHC		88/120			
Grande Punto 1.9L D Multijet Diesel						10/05 →	149	AG7440 (MLS) (30-030149-00) AG7390 (MLS), 0.82mm (30-030144-00) AG7400 (MLS), 0.92mm, 1 Hole (30-030145-00)	CG7390▲ (21-30144-00/0) EG7390 (22-30144-00/0)
939A1.000	1910	4	82.00	Direct Injection, SOHC		88/120			
Idea 1.2L 16V						01/04 →	150	AD5830 (MLS) (30-029765-00) BY380 (Fibre), 1.65mm (30-028024-30)	DY383 (21-28024-23/0) →Eng.0616937 CE5181 (21-29832-21/0) Eng.0616938 → EE5180 (22-29832-00/0)
188 A5.000	1242	4	70.80	Injection, DOHC		59/80			
Idea 1.3L D Multijet Diesel						10/05 →	151		CD5820▲ ED5820 FD5820▲
199 A3.000	1248	4	69.60	Direct Injection, DOHC		66/90			
Idea 1.3L JTD Diesel						01/04 →	152	AD5800 (MLS), 0.72mm (30-029762-00) AD5810 (MLS), 0.82mm, 1 Hole (30-029763-00) AD5820 (MLS), 0.92mm, 2 Holes (30-029764-00)	CD5810▲ ED5810 FD5810
188 A9.000	1248	4	69.60	Direct Injection, DOHC		51/70			
Idea 1.4L						10/05 →	153	AG7380 (MLS) (30-030143-00)	CG7380 (21-30143-00/0) 01/03 →
350 A1.000	1368	4	72.00	Injection, SOHC		57-55/ 78-75			
Idea 1.4L 16V						01/04 →	154	AG6220 (MLS) (30-030139-00) →04/06 AG7310 (MLS) (30-030140-00) 04/06 →	CG6220 (21-30139-00/0) →04/06 CG7310 (21-30140-00/0) 04/06 → EE5180 (22-29832-00/0)
843 A1.000	1367	4	72.00	DOHC		66-70/ 90-95			
Idea 1.9L JTD Diesel						01/04 →	155	AG7390 (MLS), 0.82mm (30-030144-00) AA5570 (MLS), 0.92mm, 1 Hole (30-029094-10) AA5580 (MLS), 1.02mm, 2 Holes (30-029095-10)	CA5560▲ (21-29093-21/0) EE5181 (22-29832-01/0)
188 B2.000	1910	4	82.00	Direct Injection, SOHC		74/100			
Linea 1.3L D Multijet Diesel						06/07 →	156		CD5820▲ ED5820 FD5820▲
199 A3.000	1248	4	69.60	Direct Injection, DOHC		66/90			
Marea 1.2L 16V						10/98 →	157	AD5830 (MLS) (30-029765-00) BY380 (Fibre), 1.65mm (30-028024-30)	DY382 (21-28024-22/0) →Eng.0616937 CE5180 (21-29832-20/0) Eng.0616937 → EE5180 (22-29832-00/0) EP280 GY383 (20-28024-03/0) →Eng.0616937
182 B2.000	1242	4	70.80	Injection		60/82			
Marea 1.4L 12V						09/95 →11/98	158	AY480 (Fibre) [249]	DX040 (21-28380-20/0) GX041
Marea 1.4L 12V 80						09/95 →11/98		BX040 (Fibre), 1.20mm (30-028380-00)	
182 A3.000	1371	4	82.00	i.e.		59/80			
182 A5.000	1371	4	82.00	i.e., SOHC		59/80			

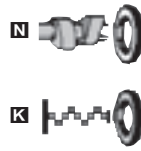
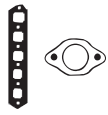

AA5570, AA5580



AD5800



AD5810



AD5820



AY480, BX040



BY380



JA5005



JA5006



JD342



JD343



JD464



JD465



JD5412



JF184



JM5176



JN972

HBS052
(22-17006B)
M9x1.25x95mm (x10)

HBS247
(22-17019B)
M9x1.25x87mm (x10)

HBS227
(22-17018B)
M12x1.25x218mm (x10)
→12/07

HBS247
(22-17019B)
M9x1.25x87mm (x10)

JA5005
(50-029899-00)
(Rubber)
JA5006
(31-029900-00)

JM5176
(50-029831-00)

HR814
(50-319374-00)

NA5053 30x42x7mm, FPM
(50-319488-00)
 NA5070 31x41x7mm, FPM
(50-319524-00)
 NF888 [3] 93x139.7x12mm, FPM
(50-319526-00)

LV695 [53]
KK5001 [45]
KK5002 [45]
KK5155 [45]
KL479 [45]

HBS353
(22-17025B)
M10x1.25x119mm (x10)

HBS353
(22-17025B)
M10x1.25x119mm (x10)

JD5411
(50-030025-00)
JD5412
(50-030026-00)
JD5413
(31-030027-00)
(MLS)

HR5088
(24-31952-10/0)

NA5223 40x52x7mm, FPM
(50-319520-00)
 NA5230 78x100x9mm, PTFE
(50-319522-00)

KK5646 [45]

HBS052
(22-17006B)
M9x1.25x95mm (x10)

HBS247
(22-17019B)
M9x1.25x87mm (x10)

JM5176
(50-029831-00)

NA5053 30x42x7mm, FPM
(50-319488-00)
 NA5058 40x55x7mm, FPM
 NA5057 27x37x7mm, FPM
 LK5001 [3] 74x187.5x17mm, FPM
(50-319456-00)

HBS227
(22-17018B)
M12x1.25x218mm (x10)

NA5053 30x42x7mm, FPM
(50-319488-00)
 NA5070 31x41x7mm, FPM
(50-319524-00)
 NF888 [3] 93x139.7x12mm, FPM
(50-319526-00)

HBS353
(22-17025B)
M10x1.25x119mm (x10)

HBS247
(22-17019B)
M9x1.25x87mm (x10)

JD464
JD465
 JF184

JM5176
(50-029831-00)

HR354 [94]

HR814
(50-319374-00)

NA5058 40x55x7mm, FPM
 NA5057 27x37x7mm, FPM
 LK5001 [3] 74x187.5x17mm, FPM
(50-319456-00)

KA5032 [53]
LV695 [53]
JR673 [11]
→06/99
KL479 [45]

HBS130
(22-17013B)
M10x1.25x163mm (x10)

JD342
(31-028783-00)
JD343
(31-027836-20)

JN972
(50-028784-00)

HR800

NA5053 30x42x7mm, FPM
(50-319488-00)
 NA5070 31x41x7mm, FPM
(50-319524-00)
 NF888 [3] 93x139.7x12mm, FPM
(50-319526-00)

HL5031 [245]

FIAT



KW/PS



Marea 1.6L		09/00 → 08/02		159		AB5150 (Fibre) (30-029342-00)	CB5150 → Eng.505161	EB5150 (22-29342-00/0)
Marea 1.6L Weekend		09/00 → 08/02				AD5970 (MLS) (30-029779-00)		FD5970 (20-29779-00/0)
182 B6.000	1596	4	80.50	i.e.	76/103			
Marea 1.6L		03/99 → 08/00		160		BX030 (Fibre), 1.65mm (30-028381-00)	DX030 (21-28381-20/0)	EB5150 (22-29342-00/0)
185 A3.000	1581	4	86.40		68-76/ 92-103	AY470 (Fibre), 1.85mm [168] (30-029903-00)		
Marea 1.6L 100 16V Bipower		04/99 →		161		BX030 (Fibre), 1.65mm (30-028381-00)	CY470 [157] (21-29903-20/0)	EB5150 (22-29342-00/0)
Marea 1.6L 16V 100		09/96 →				AY470 (Fibre), 1.85mm [249] (30-029903-00)	DX030 (21-28381-20/0)	GX030 (20-28381-00/0) → Eng.9508753
185 A3.000	1581	4	86.40		68-76/ 92-103			
182 A4.000/186 A4.000	1581	4	86.40		76/103			
Marea 1.8i 16V 115		01/95 → 08/99		162		AY500 (Fibre) [249]	DW723 ■ (21-28382-23/0)	GW723 07/99 →
182 A2.000/183 A1.000	1747	4	82.00	Euro 2	96/131	BW720 (Fibre), 1.65mm (30-028382-00)		
Marea 1.8L 16V 115		09/96 →		163		AY500 (Fibre) [249]	DW720 (21-28382-20/0)	GW724 07/99 →
182 A2.000	1747	4	82.00		96/131	BW720 (Fibre), 1.65mm (30-028382-00)		
Marea 1.9L JTD 105 Diesel		04/99 → 01/01		164		AY520 (MLS), 1.60mm, 0 Holes (30-029023-10)	CY550 ▲ (21-29023-20/0)	FY550 ▲ (20-29023-00/0)
182 B4.000	1910	4	82.00	Direct Injection, SOHC	77/105	AY530 (MLS), 1.70mm, 1 Hole (30-029024-10)		
						AY540 (MLS), 1.80mm, 2 Holes (30-029025-10)		
Marea 1.9L JTD 110 Diesel		01/01 →		165		AG7390 (MLS), 0.82mm (30-030144-00)	CA5560 ▲ (21-29093-21/0)	EE5181 (22-29832-01/0)
186 A6.000	1910	4	82.00	Direct Injection	73/99	AA5570 (MLS), 0.92mm, 1 Hole (30-029094-10)	CA5561 ▲ (21-29093-20/0)	FA5560 ▲ (20-29095-00/0)
						AA5580 (MLS), 1.02mm, 2 Holes (30-029095-10)	Eng.4081111 →	
Marea 1.9L TD 100 Diesel		09/96 →		166		BY410 (Fibre), 1.60mm (30-027854-30)	DY410 ▲ (21-28785-20/0)	GY411 ▲ (20-28785-01/0)
Marea 1.9L TD 75 Diesel		09/96 →				BY420 (Fibre), 1.70mm, 1 Notch (30-027855-30)		
182 A7.000/182 A8.000	1910	4	82.00		55/75	BY430 (Fibre), 1.80mm, 2 Notches (30-027856-30)		
						BE440 (MLS), 1.60mm (30-028978-10)		
						01/99 →		
						BE450 (MLS), 1.70mm (30-028979-10)		
						01/99 →		
						BE460 (MLS), 1.80mm (30-028980-10)		
						01/99 →		











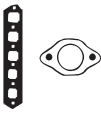

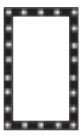

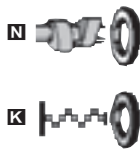

























































































































































HBS131 (22-17014B) M10x1.25x100mm (x10)		JN973 (31-028483-00)					AA5570, AA5580 HL701 	
HBS131 (22-17014B) M10x1.25x100mm (x10)	JD340 (31-028789-00) JD5143 (31-028790-10)	JN973 (31-028483-00)	JJ453		NA5187 (x2) 30x52x7mm, ACM (50-319492-00) NB818 40x56x7mm, ACM NF887 [3] 64x112.5x20mm, FPM (50-319393-00)		AB5150 JM5028 AD5970 JM5204 JN973 AY500 JP019 AY520, AY530, AY540 JP063 	
HBS131 (22-17014B) M10x1.25x100mm (x10)	JD340 (31-028789-00) JD566 JD5143 (31-028790-10)	JN973 (31-028483-00)	HR354 [94] JJ453	HR800	NA5187 (x2) 30x52x7mm, ACM (50-319492-00) NB818 40x56x7mm, ACM NF887 [3] 64x112.5x20mm, FPM (50-319393-00)	HJ282 [39]	BE440, BE450, BE460 JJ453 BW720 JJ535 	
HBS132 (22-17015B) M10x1.25x254mm (x10)	JA5007 →07/99 JD273 (31-027729-00) (MLS)	HL701 (24-28782-00/0)	JJ535 (31-028781-00)	HR800	NA5053 30x42x7mm, FPM (50-319488-00) NA5069 55x68x8mm, FPM (50-319515-00) NA5070 31x41x7mm, FPM (50-319524-00) NF888 [3] 93x139.7x12mm, FPM (50-319526-00)	HL5030 [245] KL476 [70] KA845 [13] HJ283 [39] JS069 [45]	BE440, BE450, BE460 JJ453 BW720 JJ535 	
HBS132 (22-17015B) M10x1.25x254mm (x10)	JD271 (31-027450-10) (Metal) →07/99 JD273 (31-027729-00) (MLS)	HL701 (24-28782-00/0)	JJ535 (31-028781-00)	HR800	NA5053 30x42x7mm, FPM (50-319488-00) NA5069 55x68x8mm, FPM (50-319515-00) NA5070 31x41x7mm, FPM (50-319524-00) NF888 [3] 93x139.7x12mm, FPM (50-319526-00)	HL5030 [245] KL476 [70] KA845 [13] HJ283 [39] JS069 [45]	BY410 BY420, BY430 	
HBS227 (22-17018B) M12x1.25x218mm (x10)	JD580 →12/99 JA5035 (31-029407-00) 01/00 → JD468 (31-028377-00) (MLS)	JP063		HR363	NA5053 30x42x7mm, FPM (50-319488-00) NA5070 31x41x7mm, FPM (50-319524-00) NF888 [3] 93x139.7x12mm, FPM (50-319526-00)	HL5031 [245] KL476 [70] KA845 [13] JR5001 [11]	JA5007 JA5035 JD271 JD273 JD340 	
HBS227 (22-17018B) M12x1.25x218mm (x10)	JA5035 (31-029407-00) JD580 JD468 (31-028377-00) (MLS)	JM5028 (31-029635-00) →Eng.4081110 JM5204 (50-029935-00) Eng.4081111 →		HR363	NA5053 30x42x7mm, FPM (50-319488-00) NA5070 31x41x7mm, FPM (50-319524-00) NF888 [3] 93x139.7x12mm, FPM (50-319526-00)	HL5031 [245] KL476 [70] JR5001 [11]	JD271 JD273 JD340 JD467 JD468 JD5143 JD566 JD580 	
HBS227 (22-17018B) M12x1.25x218mm (x10)	JD467 (31-028786-00) JD468 (31-028377-00) (MLS)	JP019 (50-028785-00)	HR354 [94]	HR800	NA5053 30x42x7mm, FPM (50-319488-00) NA5070 31x41x7mm, FPM (50-319524-00) NF888 [3] 93x139.7x12mm, FPM (50-319526-00)	HL5031 [245] JR5001 [11]	JD467 JD468 JD5143 JD566 JD580 	



KW/PS



Marea 2.0L 20V 150					01/01 →	167	AA5590 (MLS), 0.49mm (30-029275-00) 06/00 →	CA5590 [169]	ED5960 (22-29778-00/0)
185 A8.000	1998	5	82.00	DOHC		113/154			
Marea 2.0L 20V 150					09/96 → 04/99	168	BW320 (Fibre) (30-027452-00)	DW320 (21-27452-20/0)	GW321
182 A1.000	1998	5	82.00	DOHC		108/147			
Marea 2.0L 20V 155					04/99 → 01/01	169	BW320 (Fibre) (30-027452-00)	DW322 (21-27452-21/0)	EW320 (22-27452-00/0)
182 B7.000	1998	5	82.00	DOHC		113/154			
Marea 2.4L JTD 130 Diesel					04/99 →	170	AY550 (MLS), 1.60mm (30-029020-00) AY560 (MLS), 1.70mm, 1 Hole (30-029021-00) AY570 (MLS), 1.80mm, 2 Holes (30-029022-00)	CY520▲ [106] (21-29020-20/0)	FY520▲ [106] (20-29020-00/0)
185 A6.000 839 A5.000	2387 2387	5 5	82.00 82.00	SOHC Direct Injection, SOHC		96/131 100/136			
Marea 2.4L TD Diesel					09/96 → 04/99	171	AA5720 (MLS), 1.60mm (30-029066-00) BW340 (Fibre), 1.60mm (30-027442-20) AA5730 (MLS), 1.70mm, 1 Notch (30-029067-00) BW350 (Fibre), 1.70mm, 1 Notch (30-027443-20) → Eng.0345336 AA5740 (MLS), 1.80mm, 2 Notches (30-029068-00) BW360 (Fibre), 1.80mm, 2 Notches (30-027444-20)	DW340▲ (21-28780-20/0)	GW341▲
185 A2.000 185 A2.000	2387 2387	5 5	82.00 82.00	SOHC, Turbo SOHC		91/124 91/124			
Marengo 2.4L DS Diesel					06/78 → 12/86	172	BE580 (Fibre), 1.35mm (30-024116-10)	DE588▲ [109] (21-26037-23/0)	FY291▲ [12] (20-27426-00/0)
Sofim-8144.61.200	2445	4	93.00			53/72			
Multipla 1.6L					09/00 → 02/01	173	AB5150 (Fibre) (30-029342-00) AD5970 (MLS) (30-029779-00)	CB5150 → Eng.505169 CD5970 (21-29779-20/0) Eng.505169 →	EB5150 (22-29342-00/0) FD5970 (20-29779-00/0)
182 B6.000	1596	4	80.50	i.e.		76/103			
Multipla 1.6L					03/01 → 08/05	174	AB5150 (Fibre) (30-029342-00) AD5970 (MLS) (30-029779-00)	CB5150 → Eng.505169 CD5970 (21-29779-20/0)	EB5150 (22-29342-00/0) FD5970 (20-29779-00/0)
182 B6.000	1596	4	80.50	i.e.		76/103			
Multipla 1.6L 16V Bipower					10/01 →				
Multipla 1.6L 16V Blupower					04/02 →				















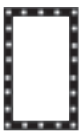



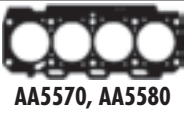
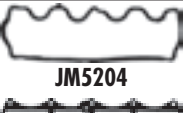

















































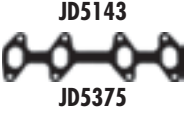













								
HBS133  (22-17016B) M10x1.25x254mm (x12)	JD225  (31-027448-00) JD226  (31-028581-00)	JM5018 (Rubber)	HR354 [94]	HR800 	 NA5053 30x42x7mm, FPM (50-319488-00)  NA5069 55x68x8mm, FPM (50-319515-00)  NA5070  31x41x7mm, FPM (50-319524-00)  NF888  [3] 93x139.7x12mm, FPM (50-319526-00)	HL5030 [245]  KA845 [13] HJ283 [39] 		 AA5590  AA5720, AA5730, AA5740  AB5150  AD5970  AY550, AY560, AY570  BE580  BW320  BW340, BW350, BW360  JA5036  JC054  JC055  JD225  JD226  JD227  JD228  JD340  JD5143  JM5018  JN462  JN594  JN933
HBS133  (22-17016B) M10x1.25x254mm (x12)	JD225  (31-027448-00) JD226  (31-028581-00)	JN933 (50-028787-00)		HR800 	 NA5053 30x42x7mm, FPM (50-319488-00)  NA5069 55x68x8mm, FPM (50-319515-00)  NA5070  31x41x7mm, FPM (50-319524-00)  NF888  [3] 93x139.7x12mm, FPM (50-319526-00)	HL5030 [245]  KA845 [13]		 JN933  JP064  JJ100  LS856  LS857
HBS133  (22-17016B) M10x1.25x254mm (x12)	JD225  (31-027448-00) JD226  (31-028581-00)	JM5018 (Rubber)		HR800 	 NA5053 30x42x7mm, FPM (50-319488-00)  NA5069 55x68x8mm, FPM (50-319515-00)  NA5070  31x41x7mm, FPM (50-319524-00)  NF888  [3] 93x139.7x12mm, FPM (50-319526-00)	HL5030 [245]  HJ283 [39] 		 AA5590  AA5720, AA5730, AA5740  AB5150  AD5970  AY550, AY560, AY570  BE580  BW320  BW340, BW350, BW360  JA5036  JC054  JC055  JD225  JD226  JD227  JD228  JD340  JD5143  JM5018  JN462  JN594  JN933
HBS257  (22-56010B) M12x1.25x218mm (x12)	JD581  →02/00 JA5036  (31-029408-00) 02/00→ JD228  (31-027837-10)	JP064		HR363 	 NA5053 30x42x7mm, FPM (50-319488-00)  NA5070  31x41x7mm, FPM (50-319524-00)  NF888  [3] 93x139.7x12mm, FPM (50-319526-00)	HL5031 [245]  KA845 [13]		 JA5036  JC054  JC055  JD225  JD226  JD227  JD228  JD340  JD5143  JM5018  JN462  JN594  JN933
HBS257  (22-56010B) M12x1.25x218mm (x12)	JD227  (31-027451-00) JD228  (31-027837-10)	JN934 (50-028780-00)		HR363 	 NA5053 30x42x7mm, FPM (50-319488-00)  NA5070  31x41x7mm, FPM (50-319524-00)  NF888  [3] 93x139.7x12mm, FPM (50-319526-00)	HL5031 [245]  KA845 [13]		 JA5036  JC054  JC055  JD225  JD226  JD227  JD228  JD340  JD5143  JM5018  JN462  JN594  JN933
HBS011  (22-51004B) M12x1.25x160mm (x10) M12x1.25x119mm (x12)	JC054  (31-024274-10) JC055  (31-025031-10)	JN462 (50-024272-00) →Eng.574798 JN594 [71] (50-026037-00) Eng.574799→	JJ100 LS856 (50-025627-00) LS857 (50-025628-00)	HR602  24-30670-61/0	 NP068 55x70x8mm, FPM (50-303186-00)  NP067  50x70x10mm, FPM (50-307111-70)  NA5055  70x90x10mm, FPM	KA546 [13] KL221 [11] LS858 [11] LS859 [11]		 JA5036  JC054  JC055  JD225  JD226  JD227  JD228  JD340  JD5143  JM5018  JN462  JN594  JN933
HBS131  (22-17014B) M10x1.25x100mm (x10)		JN973 (31-028483-00)						 JN933
HBS131  (22-17014B) M10x1.25x100mm (x10)	JD340  (31-028789-00) JD5143  (31-028790-10)	JN973 (31-028483-00)			 NA5187 (x2) 30x52x7mm, ACM (50-319492-00)  NB818  40x56x7mm, ACM  NF887  [3] 64x112.5x20mm, FPM (50-319393-00)			 JN933



KW/PS



Multipla 1.6L 16V 100				04/99 →	175	BX030 (Fibre), 1.65mm (30-028381-00) AY470 (Fibre), 1.85mm [249] (30-029903-00)	CY470 [157] (21-29903-20/0) DX030 (21-28381-20/0)	EB5150 (22-29342-00/0) GX030 (20-28381-00/0) →Eng.9508753
182 A4.000	1581	4	86.40		76/103			
Multipla 1.6L 16V Bipower				04/99 →	176	BX030 (Fibre), 1.65mm (30-028381-00) AY470 (Fibre), 1.85mm [249] (30-029903-00)	CY470 [157] (21-29903-20/0) DX030 (21-28381-20/0)	EB5150 (22-29342-00/0)
186 A4.000	1581	4	86.40		76/103			
Multipla 1.6L 16V Blupower				04/99 →	177	BX030 (Fibre), 1.65mm (30-028381-00) AY470 (Fibre), 1.85mm [249] (30-029903-00)	CY470 [157] (21-29903-20/0) DX030 (21-28381-20/0)	GX030 (20-28381-00/0) →Eng.9508753
186 A3.000	1581	4	86.40		76/103			
Multipla 1.9L JTD 105 Diesel				04/99 →	178	AY520 (MLS), 1.60mm, 0 Holes (30-029023-10) AY530 (MLS), 1.70mm, 1 Hole (30-029024-10) AY540 (MLS), 1.80mm, 2 Holes (30-029025-10)	CY550 ▲ (21-29023-20/0)	FY550 ▲ (20-29023-00/0)
182 B4.000	1910	4	82.00	Direct Injection, SOHC	77/105			
Multipla 1.9L JTD 110 Diesel				03/01 →07/02	179	AG7390 (MLS), 0.82mm (30-030144-00) AA5570 (MLS), 0.92mm, 1 Hole (30-029094-10) AA5580 (MLS), 1.02mm, 2 Holes (30-029095-10)	CA5560 ▲ (21-29093-21/0) CA5561 ▲ (21-29093-20/0) Eng.4081111 →	EE5181 (22-29832-01/0) FA5560 ▲ (20-29095-00/0)
186 A6.000	1910	4	82.00	Direct Injection	73/99			
Multipla 1.9L JTD 115 Diesel				07/02 →	180	AG7390 (MLS), 0.82mm (30-030144-00) AA5570 (MLS), 0.92mm, 1 Hole (30-029094-10) AA5580 (MLS), 1.02mm, 2 Holes (30-029095-10)	CA5560 ▲ (21-29093-21/0) CA5561 ▲ (21-29093-20/0)	
186 A8.000	1910	4	82.00	Direct Injection, SOHC	85/115			
Multipla 1.9L JTD Diesel				04/02 →	181			
186A9.000	1910	4	82.00	Direct Injection	88/120			
Palio 1.2L				02/01 →	182	AE5240 (MLS) (30-029844-00) AE5550 (Fibre) [249] (30-029928-00) BV670 (Fibre) (30-027185-00)	DV672 [163] (21-27185-22/0) CE5242 Eng.2939661 →	EE5242 EV670 (22-27185-00/0)
188 A4.000	1242	4	70.80	Injection	44/60			
Palio 1.2L				07/97 →08/02	183	AE5240 (MLS) (30-029844-00) AE5550 (Fibre) [249] (30-029928-00) BV670 (Fibre) (30-027185-00)	DV672 [163] (21-27185-22/0) 188A4.000 DV675 (21-27185-00/0) 178B74.066 178C4.066	EV670 (22-27185-00/0)
178 B7.045	1242	4	70.80	SOHC	44/60			
188 A4.000	1242	4	70.80	Injection	44/60			
178 C4.066	1242	4	70.80	Injection, SOHC				
Palio 1.2L				09/99 →	184	AD5830 (MLS) (30-029765-00) BY380 (Fibre), 1.65mm (30-028024-30)	DY383 (21-28024-23/0) →Eng.0616937 CE5181 (21-29832-21/0) Eng.0616937 →	EE5180 (22-29832-00/0) GY383 (20-28024-03/0)
188 A5.000	1242	4	70.80	Fire, Injection, DOHC	59/80			











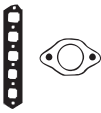

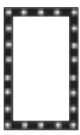

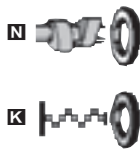





































































									
HBS131  (22-17014B) M10x1.25x100mm (x10)	JD340  (31-028789-00) JD566  JD5143  (31-028790-10)	JN973 (31-028483-00)	HR354 [94] JJ453	HR800 	NA5187 (x2) 30x52x7mm, ACM (50-319492-00) NB818  40x56x7mm, ACM NF887  [3] 64x112.5x20mm, FPM (50-319393-00)	HJ282 [39] 		AE5240 AY520, AY530, AY540	JN973 JP063 JJ453
HBS131  (22-17014B) M10x1.25x100mm (x10)	JD340  (31-028789-00) JD5143  (31-028790-10)	JN973 (31-028483-00)	JJ453	HR800 	NA5187 (x2) 30x52x7mm, ACM (50-319492-00) NB818  40x56x7mm, ACM NF887  [3] 64x112.5x20mm, FPM (50-319393-00)			BV670 BX030, AY470	
HBS131  (22-17014B) M10x1.25x100mm (x10)	JD340  (31-028789-00) JD566  JD5143  (31-028790-10)	JN973 (31-028483-00)	HR354 [94] JJ453	HR800 	NA5187 (x2) 30x52x7mm, ACM (50-319492-00) NB818  40x56x7mm, ACM NF887  [3] 64x112.5x20mm, FPM (50-319393-00)	HJ282 [39] 		BY380	
HBS227  (22-17018B) M12x1.25x218mm (x10)	JD580  →02/00 JA5035  (31-029407-00) (Metal) 02/00→ JD468  (31-028377-00) (MLS)	JP063		HR363 	NA5053 30x42x7mm, FPM (50-319488-00) NA5070  31x41x7mm, FPM (50-319524-00) NF888  [3] 93x139.7x12mm, FPM (50-319526-00)	HL5031 [245]  KA845 [13]			JA5005
HBS227  (22-17018B) M12x1.25x218mm (x10)	JA5035  (31-029407-00) JD580  JD468  (31-028377-00) (MLS)	JM5028 (31-029635-00) →Eng.4081110 JM5204 (50-029935-00) Eng.4081111 →		HR363 	NA5053 30x42x7mm, FPM (50-319488-00) NA5070  31x41x7mm, FPM (50-319524-00) NF888  [3] 93x139.7x12mm, FPM (50-319526-00)	HL5031 [245]  KL476 [70] JR5001 [11]			JA5010
HBS227  (22-17018B) M12x1.25x218mm (x10)				HR363 	NA5053 30x42x7mm, FPM (50-319488-00) NA5070  31x41x7mm, FPM (50-319524-00) NF888  [3] 93x139.7x12mm, FPM (50-319526-00)	HL5031 [245] 			JA5035
HBS227  (22-17018B) M12x1.25x218mm (x10)									JD340
HBS227  (22-17018B) M12x1.25x218mm (x10)									JD468
HBS227  (22-17018B) M12x1.25x218mm (x10)									JD5143
HBS052  (22-17006B) M9x1.25x95mm (x10)	JA5010  JD5375  (x2) (31-029968-00)	JM5019 JM5181 (50-029843-00) (Rubber)	HR354 [94]	HR800 	NA5053 30x42x7mm, FPM (50-319488-00) NB815  23x35x7mm, FPM (50-319523-00) NA5061  74x88x8mm, FPM	HL5024 [245]  LV695 [53] JR673 [11] LB177 [46]			JD566
HBS052  (22-17006B) M9x1.25x95mm (x10)	JA5010 	JM5019 JM5181 (50-029843-00) (Rubber)			NA5053 30x42x7mm, FPM (50-319488-00) NB815  23x35x7mm, FPM (50-319523-00) NA5061  74x88x8mm, FPM	HL5024 [245] 			JM5019
HBS247  (22-17019B) M9x1.25x87mm (x10)	JA5005  (50-029899-00) (Rubber) JA5006  (31-029900-00)	JM5176 (50-029831-00)		HR814 	NA5058 40x55x7mm, FPM NA5057  27x37x7mm, FPM LK5001  [3] 74x187.5x17mm, FPM (50-319456-00)	LV695 [53] KK5001 [45] KK5002 [45] KK5155 [45] KL479 [45]			JM5028
									JM5176



KW/PS



Palio 1.2L		05/95 → 06/00			185	AE5240 (MLS) (30-029844-00)	DV675 (21-27185-00/0)	EV670 (22-27185-00/0)
176 A8.000	1242	4	70.80	Fire, Injection	54/73	AE5550 (Fibre) [249] (30-029928-00)		GV671
176 B4.000	1242	4	70.80	Fire, Injection, SOHC	54/73	BV670 (Fibre) (30-027185-00)		
178E2.000	1242	4	70.80	Fire, Injection	54/73			
Palio 1.2L		06/98 →			186	AE5240 (MLS) (30-029844-00)	DV675 (21-27185-00/0)	EV670 (22-27185-00/0)
178E2.000	1242	4	70.80	Injection	54/73	AE5550 (Fibre) [249] (30-029928-00)		GV671
						BV670 (Fibre) (30-027185-00)		
Palio 1.2L		04/96 → 02/01			187	AE5240 (MLS) (30-029844-00)	CE5240 [162] (21-29844-20/0)	EV670 (22-27185-00/0)
178 B5.000	1242	4	70.80	Injection	44/60	AE5550 (Fibre) [249] (30-029928-00)	DV672 [163] (21-27185-22/0)	
						BV670 (Fibre) (30-027185-00)		
Palio 1.3L JTD Multijet Diesel		06/03 →			188		CD5810▲	ED5810 FD5810
188 A9.000	1248	4	69.60	Direct Injection, DOHC	51/70			
Palio 1.4L		04/96 →			189	BR620 (Fibre) [249] (30-027865-00)	DR620 (21-26295-21/0)	ET400 GR620
178 B2.000/178B2.016	1372	4	80.50	SPi, SOHC	51/69			
Palio 1.6L 16V		02/01 →			190	AB5150 (Fibre) (30-029342-00)	CB5150 → Eng.505168	EB5150 (22-29342-00/0)
182 B6.000	1596	4	80.50	i.e.	76/103	→ Eng.505168	CD5970 (21-29779-20/0)	FD5970 (20-29779-00/0)
						AD5970 (MLS) (30-029779-00)		
						Eng.505169 →		
Palio 1.6L 16V		04/96 → 02/01			191	BX030 (Fibre), 1.65mm (30-028381-00)	CY470 [157] (21-29903-20/0)	EB5150 (22-29342-00/0)
178 B3.000	1581	4	86.40		74-78/ 101	AY470 (Fibre), 1.85mm [249] (30-029903-00)	DX030 (21-28381-20/0)	ET400 GX030 (20-28381-00/0)
								→ Eng.9508753
Palio 1.7L TD Diesel		04/96 → 03/01			192	BR680 (Graphite), 1.65mm	DV680▲ (21-25142-26/0)	EV684 (22-25142-00/0)
146 D7.000/176 A5.000	1697	4	82.60	Turbo	46/63	AC5140 (MLS), 1.66mm (30-026296-20)		GV680▲ [100]
176 B7.000	1697	4	82.60	SOHC, Turbo	46/63	BV680 (Fibre), 1.67mm, 0 Notches (30-026296-10)		
176 A3.000	1697	4	82.60		51-53/ 69	BV690 (Fibre), 1.75mm, 1 Notch (30-026296-10)		
						AC5150 (MLS), 1.76mm (30-026297-20)		
						AC5170 (MLS), 1.76mm		
						BV700 (Fibre), 1.85mm, 2 Notches (30-027859-00)		
						BW980 (Fibre), 1.93mm, 3 Notches		
						AC5160 (MLS), 1.96mm (30-026298-20)		
Palio 1.9L D Diesel		09/00 →			193	BZ790 (MLS), 0.80mm (30-028707-00)	DZ790▲ (21-28707-20/0)	EE5181 (22-29832-01/0)
223 A6.000	1910	4	82.00		44/60	BZ800 (MLS), 0.90mm, 1 Notch (30-028708-00)		GZ790▲
						BZ810 (MLS), 1.00mm, 2 Notches (30-028709-00)		

									
HBS052  (22-17006B) M9x1.25x95mm (x10)	JD150  JD5375  (31-029968-00)	JN667 (50-026094-00)	HR354 [94]	HR599  (24-31919-10/0)	 NA5053 30x42x7mm, FPM (50-319488-00)  NB815  23x35x7mm, FPM (50-319523-00)  NA5061  74x88x8mm, FPM	HL5024 [245]  LV695 [53] JR673 [11]		AB5150 AC5140, AC5150, AC5160 AC5170	JD5375 JD566 JF145 JF184
HBS052  (22-17006B) M9x1.25x95mm (x10)	JD150  JD5375  (31-029968-00)  JF145 (MLS)  JF184	JN667 (50-026094-00) JN667C1 (Rubber)	HR354 [94]	HR599  (24-31919-10/0)	 NA5053 30x42x7mm, FPM (50-319488-00)  NB815  23x35x7mm, FPM (50-319523-00)  NA5061  74x88x8mm, FPM	HL5024 [245]  KA5032 [53] LV695 [53] JR673 [11] LB177 [46]		AD5970 AE5240	JD5375 JM5003
HBS052  (22-17006B) M9x1.25x95mm (x10)	JA5010  JD5375  (x2) (31-029968-00)	JM5019	HR354 [94]	HR800 	 NA5053 30x42x7mm, FPM (50-319488-00)  NB815  23x35x7mm, FPM (50-319523-00)  NA5061  74x88x8mm, FPM	HL5024 [245]  LV695 [53] JR673 [11] LB177 [46]		BR620 BR680	JM5019 JN459
HBS353  (22-17025B) M10x1.25x119mm (x10)								BR80	JN667
HBS051  (22-17001B) M10x1.25x98mm (x5) M10x1.25x84mm (x5)					 NA5187 30x52x7mm, ACM (50-319492-00)  NB818  40x56x7mm, ACM			BV670	JN973
HBS131  (22-17014B) M10x1.25x100mm (x10)	JD340  (31-028789-00) JD566  JD5143  (31-028790-10)	JN973 (31-028483-00)			 NA5187 (x2) 30x52x7mm, ACM (50-319492-00)  NB818  40x56x7mm, ACM  NF887  [3] 64x112.5x20mm, FPM (50-319393-00)			BV680, BV690, BV700, BW980	JJ298
HBS131  (22-17014B) M10x1.25x100mm (x10)	JD340  (31-028789-00) JD566  JD5143  (31-028790-10)	JN973 (31-028483-00)	HR354 [94] JJ453	HR800 	 NA5187 (x2) 30x52x7mm, ACM (50-319492-00)  NB818  40x56x7mm, ACM  NF887  [3] 64x112.5x20mm, FPM (50-319393-00)	HJ282 [39] 		BX030, AY470	JJ398
HBS095  (22-17007B) M12x1.25x133mm (x10)	JC738 (31-026290-10)	JN459 (31-025142-10)	JJ298 → Eng.9185 JJ398 (31-027379-00)	HR596 	 NA5187 30x52x7mm, ACM (50-319492-00)  NB742  30x43x8mm, ACM (50-319408-00)  NB732  74x90x10mm, FPM  NA5062  74x90x10mm, ACM	LV583 [53] LV589 [11] LT498 [45] LV582 [45]		JA5008 JA5010 JA5011	JA5008 JA5010 JA5011
HBS227  (22-17018B) M12x1.25x218mm (x10)	JA5008  (31-029958-00) (Rubber) JA5011  (31-029959-00) (Rubber) JD468  (31-028377-00) (MLS)	JM5003 (50-029960-00)		HR363 	 NA5053 30x42x7mm, FPM (50-319488-00)  NA5070  31x41x7mm, FPM (50-319524-00)  NF888  [3] 93x139.7x12mm, FPM (50-319526-00)	HL5031 [245]  KL476 [70] KA845 [13] JR5001 [11] KK5004 [155]		JD150 JD340 JD468 JD5143	JD150 JD340 JD468 JD5143

FIAT



KW/PS



Panda 650					01/82 → 07/04	194	BP050 (Fibre)	DP051	GP051
141 A.000	652	2	77.00			22/30			
Panda 750					01/95 → 12/97	195	BP280 (Fibre), 1.65mm (30-026046-30) BV940 (Fibre), 2.00mm (30-028799-00)	CV940 [170] (21-28799-21/0) DV675 (21-27185-00/0)	GP282 [171] (20-26046-00/0)
156 A4.048	770	4	65.00	SOHC		25/34			
Panda 750					01/86 → 01/95	196	BP520 (Fibre), 1.20mm (30-026522-20) BP030 (Fibre), 1.80mm (30-025210-20)	DR611 [153] Eng.8061128 → DS570 [154] Eng.8061128 →	GR611 [153] (20-26522-01/0)
141 B.000	770	4	65.00			25/34			
Panda 750					01/86 → 01/95	197	BP660 (Fibre) (30-026045-10)	DP660 [153] (21-26045-20/0)	GP660
156 A4.000	770	4	65.00			25/34			
Panda 0.9L 45					01/74 →	198	BP520 (Fibre), 1.20mm (30-026522-20) BP030 (Fibre), 1.80mm (30-025210-20)	CG01A [153] DP011 [153] (21-26522-20/0) → Eng.8064870 DR610 [154] Eng.8064870 →	GP011
Panda 0.9L 45 Super/Young					01/74 →				
100 GF 000/ 100 GL.000/100 GL.048	903	4	65.00			34/46			
100 GL3.000/127 A.000	903	4	65.00	OHV		34/46			
Panda 900					10/80 → 06/94	199	BP520 (Fibre), 1.20mm (30-026522-20) BP030 (Fibre), 1.80mm (30-025210-20)	CG01A [153] → Eng.8064870 DP011 [153] (21-26522-20/0) → Eng.8064870 DR610 [154] → Eng.8064870	GP011 → Eng.8064870
146 A.000	903	4	65.00	SOHC		33/45			
100 GL3.000	903	4	65.00	OHV		34/46			
Panda 900					04/92 → 12/96	200	AY430 (Fibre) (30-028975-00) BT260 (Fibre) (30-027165-10)	DT260 (21-27165-20/0)	GT260 [158] (20-27165-00/0)
1170 A1.046	899	4	65.00	SOHC		30/41			
Panda 950					09/82 → 08/83	201	BP510 (Fibre), 1.20mm (30-024115-10) BP500 (Fibre), 1.80mm	DP022 [153]	GP022
A 112 B1.054	965	4	67.20	OHV		35/47			
Panda 1000					01/86 → 04/92	202	BP280 (Fibre), 1.65mm (30-026046-30) BV940 (Fibre), 2.00mm (30-028799-00)	CV940 [170] (21-28799-21/0) DV675 (21-27185-00/0)	
156 A2.100	999	4	70.00	SOHC		41/55			
Panda 1000					01/86 → 02/92	203	BP280 (Fibre), 1.65mm (30-026046-30) BV940 (Fibre), 2.00mm (30-028799-00)	DV675 (21-27185-00/0)	GP282 [171] (20-26046-00/0)
Panda 1000 4x4					01/86 → 07/89				
Panda 1000 i.e					08/92 → 02/04				
Panda 1000 i.e.					10/87 → 08/98				
156 A3.100	999	4	70.00	SOHC		32-33/ 44-45			
141 C2.000	999	4	70.00	SOHC		33/45			
156 A2.246	999	4	70.00	SPI, SOHC		33/45			
156 A2.100	999	4	70.00	SOHC		41/55			

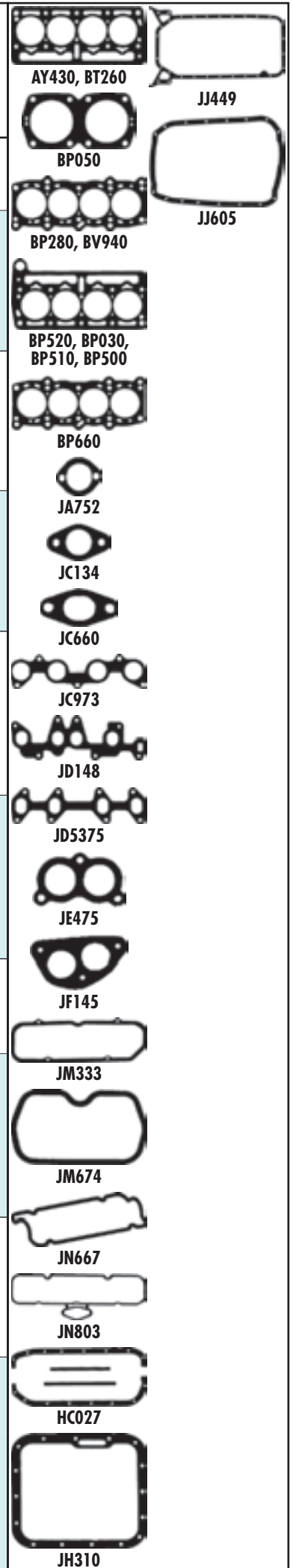
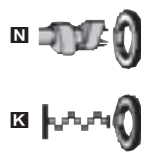
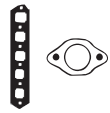











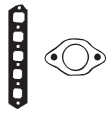

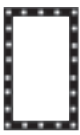

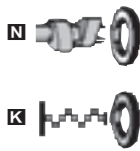

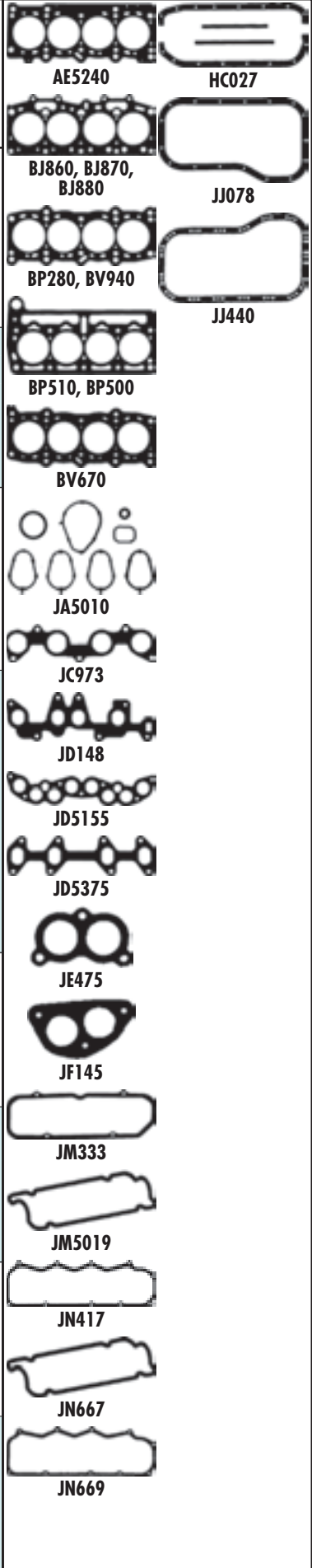



















































































































	JA752 (x2) JC134 (x2)	JM674	JH310	PA052	NB727 [152] 45x62x10mm, ACM (50-319477-00) NB728 [152] 53x68x10mm, ACM	KD726 [91] JR087 [11] KS176 [11]
HBS052 (22-17006B) M9x1.25x95mm (x10)					NA5053 30x42x7mm, FPM (50-319488-00) NB815 23x35x7mm, FPM (50-319523-00) NB814 70x88x8mm, FPM (50-306350-50)	
HBS297 (22-17022B) M9x1.25x91mm (x9) M9x1.25x56mm (x1)	JC973 (31-021833-10)	JM333 (31-021029-00)	JJ449	HR596	NB633 42x63x7mm, ACM (50-319184-00) NA5049 64x80x8mm, ACM	KD226 [91] KT600 [11] KS830 [46] →12/92 KT753 [46] LS649 [46]
HBS052 (22-17006B) M9x1.25x95mm (x10)	JD148 (31-025907-10) JC660 (31-025922-10)	JN667 (50-026094-00) JN667C1 (Rubber)			NA5053 30x42x7mm, FPM (50-319488-00) NB815 23x35x7mm, FPM (50-319523-00) NB814 70x88x8mm, FPM (50-306350-50)	HL5024 [245] S KA5032 [53] LV695 [53] JR673 [11]
HBS109 (22-17009B) M9x1.25x60mm (x1) M9x1.25x95mm (x9)	JC973 (31-021833-10)	JM333 (31-021029-00)	HC027 (23-17373-01/0)	HR599 (24-31919-10/0)	NB633 42x63x7mm, ACM (50-319184-00) NA5049 64x80x8mm, ACM NB808 64x80x8mm, FPM	JR154 [11] KS830 [46] KT446 [46] KT753 [46] LS649 [46]
HBS109 (22-17009B) M9x1.25x60mm (x1) M9x1.25x95mm (x9)	JC973 (31-021833-10)	JM333 (31-021029-00)	HC027 (23-17373-01/0) →Eng.8064870	HR599 (24-31919-10/0)	NB633 42x63x7mm, ACM (50-319184-00) NA5049 64x80x8mm, ACM NB808 64x80x8mm, FPM	HJ274 [39] S KD226 [91] KD747 [91] JR154 [11]
HBS297 (22-17022B) M9x1.25x91mm (x9) M9x1.25x56mm (x1)	JC973 (31-021833-10)	JN803 (50-027374-00)	JJ449 JJ605	HR599 (24-31919-10/0)	NA5177 42x56x7mm, FPM (50-319189-00) NB808 64x80x8mm, FPM	LR922 [70] KA295 [13] HJ291 [39] S KT600 [11]
	JC973 (31-021833-10) JE475	JM333 (31-021029-00)	HC027 (23-17373-01/0) →Eng.8064870	HR599 (24-31919-10/0)	NB633 42x63x7mm, ACM (50-319184-00) NA5049 64x80x8mm, ACM	HJ280 [39] S JR154 [11] KT600 [11] KS830 [46] KT446 [46] KT753 [46] LS649 [46]
HBS052 (22-17006B) M9x1.25x95mm (x10)	JD148 (31-025907-10) JD5375 (31-029968-00)	JN667 (50-026094-00) JN667C1 (Rubber)	HR354 [94]	HR599 (24-31919-10/0)	NA5053 30x42x7mm, FPM (50-319488-00) NB815 23x35x7mm, FPM (50-319523-00) NB814 70x88x8mm, FPM (50-306350-50)	KA5032 [53] LV695 [53] HJ280 [39] S HJ292 [39] S JR673 [11] LB177 [46]
HBS052 (22-17006B) M9x1.25x95mm (x10)	JD148 (31-025907-10) JD5375 (31-029968-00) JF145 (MLS)	JN667 (50-026094-00) JN667C1 (Rubber)	HR354 [94]	HR599 (24-31919-10/0)	NA5053 30x42x7mm, FPM (50-319488-00) NB815 23x35x7mm, FPM (50-319523-00) NB814 70x88x8mm, FPM (50-306350-50)	HL5024 [245] S KA5032 [53] LV695 [53] HJ280 [39] S HJ292 [39] S JR673 [11] LB177 [46]

FIAT



KW/PS













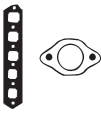

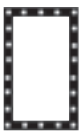

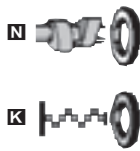



















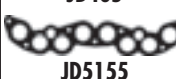











































































								
		JC973  (31-021833-10)  JE475	JM333 (31-021029-00)	HC027  (23-17373-01/0) → Eng.8064870	HR599  (24-31919-10/0)	 NB633  42x63x7mm, ACM (50-319184-00)  NA5049  64x80x8mm, ACM	HJ280  ^[39] JR154  ^[11] KT600  ^[11] KS830  ^[46] KT446  ^[46] KT753  ^[46] LS649  ^[46]	
HBS052  (22-17006B) M9x1.25x95mm (x10)	JA5010  JD5375  (31-029968-00)  JF145 (MLS)	JM5019	HR354  ^[94]	HR599  (24-31919-10/0)	 NA5053 30x42x7mm, FPM (50-319488-00)  NA5057  27x37x7mm, FPM  NB815  23x35x7mm, FPM (50-319523-00)  NA5061  74x88x8mm, FPM	HL5024  ^[245]  LV695  ^[53] JR673  ^[11] LB177  ^[46]		
HBS052  (22-17006B) M9x1.25x95mm (x10)	JD148  (31-025907-10) JD5375  (31-029968-00)  JF145 (MLS)	JN667 (50-026094-00) JN667C1 (Rubber)	HR354  ^[94]	HR599  (24-31919-10/0)	 NA5053 30x42x7mm, FPM (50-319488-00)  NB815  23x35x7mm, FPM (50-319523-00)  NB814  70x88x8mm, FPM (50-306350-50)	HL5024  ^[245]  KA5032  ^[53] LV695  ^[53] HJ274  ^[39]  ^[39] HJ280  ^[39]  ^[11] JR673  ^[11] LB177  ^[46]		
HBS052  (22-17006B) M9x1.25x95mm (x10)	JA5010  187A1.000 JD148  (31-025907-10) 176B2.00 JD5375  (31-029968-00) 176B2.00 187A1.000  JF145 (MLS)	JM5019 187A1.000 JN667 (50-026094-00) 176B2.00	HR354  ^[94]	HR599  (24-31919-10/0)	 NA5053 30x42x7mm, FPM (50-319488-00)  NA5057  27x37x7mm, FPM  NB815  23x35x7mm, FPM (50-319523-00)  NA5061  74x88x8mm, FPM	HL5024  ^[245]  JR673  ^[11]		
HBS052  (22-17006B) M9x1.25x95mm (x10)	JD148  (31-025907-10) JD5375  (31-029968-00)  JF145 (MLS)	JN667 (50-026094-00)	HR354  ^[94]	HR599  (24-31919-10/0)	 NA5053 30x42x7mm, FPM (50-319488-00)  NA5057  27x37x7mm, FPM  NB815  23x35x7mm, FPM (50-319523-00)  NA5061  74x88x8mm, FPM	HL5024  ^[245]  JR673  ^[11]		
HBS052  (22-17006B) M9x1.25x95mm (x10)	JA5010  JD5375  (x2) (31-029968-00)	JM5019 JM5181 (50-029843-00) (Rubber)	HR354  ^[94]	HR800 	 NA5053 30x42x7mm, FPM (50-319488-00)  NB815  23x35x7mm, FPM (50-319523-00)  NA5061  74x88x8mm, FPM	HL5024  ^[245]  KA5032  ^[53] LV695  ^[53] JR673  ^[11] LB177  ^[46]		
HBS052  (22-17006B) M9x1.25x95mm (x10)	JA5010  JD5375  (x2) (31-029968-00)	JM5019 JM5181 (50-029843-00) (Rubber)	HR354  ^[94]	HR800 	 NA5053 30x42x7mm, FPM (50-319488-00)  NB815  23x35x7mm, FPM (50-319523-00)  NA5061  74x88x8mm, FPM	HL5024  ^[245]  KA5032  ^[53] LV695  ^[53] JR673  ^[11] LB177  ^[46]		
	JD5155 (31-029308-00)	JN417 JN669 (31-025319-00) (Cork)	JJ078 JJ440 (31-027495-00)	HR596 	 NA5187 30x52x7mm, ACM (50-319492-00)  NA5051  40x56x7mm, FPM  NA5052  70x85x8mm, FPM	KA294  ^[13]		



KW/PS



Model		Year Range	Code	Power (KW/PS)	Engine Details	Accessories	Notes
Panda 1.3L JTD Diesel		09/03 →	212			AD5800 (MLS), 0.72mm (30-029762-00)	CD5810▲
Panda 1.3L JTD 4x4 Diesel		10/04 →				AD5810 (MLS), 0.82mm, 1 Hole (30-029763-00)	ED5810 FD5810
188 A9.000	1248	4	69.60	Direct Injection, DOHC	51/70	AD5820 (MLS), 0.92mm, 2 Holes (30-029764-00)	
169 A1.000	1248	4	69.60	Direct Injection, DOHC			
Panda 1300 D Diesel		04/86 →12/92	213			BJ860 (Fibre), 1.65mm (30-026451-10)	DJ872▲ (21-25319-21/0)
156 A5.000	1301	4		76.10		33/44	BJ870 (Fibre), 1.80mm, 1 Notch (30-026452-10)
						BJ880 (Fibre), 1.95mm, 2 Notches (30-026453-10)	GJ872▲
Panda 1.4L		10/06 →	214			AG6220 (MLS) (30-030139-00)	CG6220 (21-30139-00/0)
169 A3.000	1368	4		72.00	Injection, DOHC		→04/06
Premio 1.6L		03/85 →12/96	215			AY460 (Fibre) [249]	DR630 (21-26294-21/0)
159 A3.000	1581	4		86.40	Carburettor, SOHC	63/86	→12/93
						BR630 (Fibre) (30-027866-00)	DR631 (21-27866-20/0)
							159 B9.000
							DR632 (21-27866-21/0)
							01/94 →
Punto 1.1L		04/96 →02/00	216			BP280 (Fibre), 1.65mm (30-026046-30)	DV675 (21-27185-00/0)
176 B2.000	1108	4		70.00	SPI	40/54	
						BV940 (Fibre), 2.00mm (30-028799-00)	GP285
Punto 1.1L 55		09/93 →09/99	217			BP280 (Fibre), 1.65mm (30-026046-30)	CV940 [170] (21-28799-21/0)
176 A6.000	1108	4		70.00		40/54	
176 B2.000	1108	4	70.00	SPI	40/54	BV940 (Fibre), 2.00mm (30-028799-00)	EP280 GP285
						176 A6.000	176 A6.000
							DV675 (21-27185-00/0)
Punto 1.2L 16V 80		09/99 →	218			AD5830 (MLS) (30-029765-00)	DY383 (21-28024-23/0)
188 A5.000	1242	4		70.80	Injection, DOHC	59/80	→Eng.0616937
						BY380 (Fibre), 1.65mm (30-028024-30)	EE5180 (22-29832-00/0)
							GY383 (20-28024-03/0)
Punto 1.2L 16V 85		04/97 →09/99	219			AD5830 (MLS) (30-029765-00)	DY382 (21-28024-22/0)
176 B9.000	1242	4		70.80	Injection	63/86	→Eng.0616937
						BY380 (Fibre), 1.65mm (30-028024-30)	EE5180 (22-29832-00/0)
							→06/99
							EP280 GY383 (20-28024-03/0)
							→Eng.0616937







								
HBS353  (22-17025B) M10x1.25x119mm (x10)	JD5411  (50-030025-00) JD5412  (50-030026-00) JD5413  (31-030027-00) (MLS)	JM5259 (31-030023-00)		HR5088  (24-31952-10/0)	NA5223  (50-319520-00) NA5230  (50-319522-00)	KK5646 [45]		 AD5800  JM5176  AD5810  AD5820  AY460, BR630  BJ860, BJ870, BJ880  BP280, BV940  BY380  JA5005  JA5006  JR673  LB177  JD464  JD465  JD5155  JD5375  JD5412  JF145  JF184
	JD5155 (31-029308-00)	JN417 JN669 (31-025319-00) (Cork)	JJ078 JJ440 (31-027495-00)	HR596 	NA5187  (50-319492-00) NA5051  (50-319522-00) NA5052  (50-319522-00)	KA294 [13] LA163 [53] LS488 [53] HJ274 [39]  KD717 [91]		 JN417  JN667  JN669  JJ078  JJ440
HBS247  (22-17019B) M9x1.25x87mm (x10)								
HBS051  (22-17001B) M10x1.25x98mm (x5) M10x1.25x84mm (x5)					NA5187  (50-319492-00)			
HBS052  (22-17006B) M9x1.25x95mm (x10)	JD148  (31-025907-10) JD5375  (31-029968-00)  JF145 (MLS)	JN667 (50-026094-00) JN667C1 (Rubber)		HR599  (24-31919-10/0)	NA5053  (50-319488-00) NB815  (50-319523-00) NA5061  (50-319523-00)	HL5024 [245]  KA5032 [53] LV695 [53] HJ280 [39]  JR673 [11] LB177 [46]		 JA5005  JA5006  JR673  LB177  JD464  JD465  JD5155  JD5375  JD5412  JF145  JF184
HBS052  (22-17006B) M9x1.25x95mm (x10) 176 A6.000	JD148  (31-025907-10) 176 A6.000 JD5375  (31-029968-00) (x2) 176 A6.000  JF145 (MLS) 176 A6.000	JN667 (50-026094-00) 176 A6.000	HR354 [94] 176 A6.000	HR599  (24-31919-10/0)	NA5053  (50-319488-00) NB815  (50-319523-00) NA5061  (50-319523-00)	HL5024 [245]  KA5032 [53] 176 A6.000 LV695 [53] 176 A6.000 HJ280 [39]  176 A6.000 JR673 [11] 176 A6.000 LB177 [46] 176 A6.000		 JA5005  JA5006  JR673  LB177  JD464  JD465  JD5155  JD5375  JD5412 JF145 JF184
HBS247  (22-17019B) M9x1.25x87mm (x10)	JA5005  (50-029899-00) (Rubber) JA5006  (31-029900-00)  KK5157	JM5176 (50-029831-00)		HR814  (50-319374-00)	NA5058  (50-319456-00) NA5057  (50-319456-00) LK5001  (3) 74x187.5x17mm, FPM	KA5032 [53] LV695 [53] KK5001 [45] KK5002 [45] KK5155 [45] KL479 [45]		 JA5005  JA5006  JR673  LB177  JD464  JD465 JD5155 JD5375 JD5412 JF145 JF184
HBS247  (22-17019B) M9x1.25x87mm (x10)	JD464  JD465   JF184	JM5176 (50-029831-00)	HR354 [94]	HR814  (50-319374-00)	NA5058  (50-319456-00) NA5057  (50-319456-00) NA5061  (50-319456-00)	JR673 [11] →06/99		 JA5005  JA5006  JR673  LB177  JD464 JD465 JD5155 JD5375 JD5412 JF145 JF184

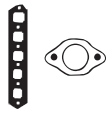

KW/PS

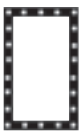

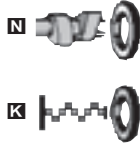
Punto 1.2L 60		09/99 →		220		AE5240 (MLS) (30-029844-00)	DV672 [1 63] (21-27185-22/0)	
Punto 1.2L Natural Power		09/03 →				AE5550 (Fibre) [249] (30-029928-00)	CE5242 Eng.2939661 →	
188 A4.000	1242	4	70.80	Injection	44/60	BV670 (Fibre) (30-027185-00)		
Punto 1.2L 60		01/94 → 09/99		221		AE5240 (MLS) (30-029844-00)	DV675 (21-27185-00/0)	EP280 GV670 (20-27185-00/0)
176 A7.000	1242	4	70.80	SPI	44/60	AE5550 (Fibre) [249] (30-029928-00)		
Punto 1.2L 60		03/94 → 09/99		222		AE5240 (MLS) (30-029844-00)	DV675 (21-27185-00/0)	EV670 (22-27185-00/0)
Punto Convertible 1.2L 60		05/95 → 06/00				AE5550 (Fibre) [249] (30-029928-00)		GV671
176 B1.000	1242	4	70.80	SOHC	44/60	BV670 (Fibre) (30-027185-00)		
176 B4.000	1242	4	70.80	Injection, SOHC	54/73			
Punto 1.2L 75		01/94 → 09/99		223		AE5240 (MLS) (30-029844-00)	DV675 (21-27185-00/0)	EV670 (22-27185-00/0)
176 A8.000	1242	4	70.80	Injection	54/73	AE5550 (Fibre) [249] (30-029928-00)		GV671
Punto Convertible 1.2L 16V 85		04/97 → 06/00		224		AD5830 (MLS) (30-029765-00)	DY382 (21-28024-22/0)	EE5180 (22-29832-00/0)
176 B9.000	1242	4	70.80	Injection	63/86	BY380 (Fibre), 1.65mm (30-028024-30)	→ Eng.0616937 CE5180 (21-29832-20/0)	→ 06/99 GY383 (20-28024-03/0)
Punto Convertible 1.2L 60		04/94 → 06/00		225		AE5240 (MLS) (30-029844-00)	DV675 (21-27185-00/0)	GV670 (20-27185-00/0)
176 A7.000	1242	4	70.80	SPI	44/60	AE5550 (Fibre) [249] (30-029928-00)		
Punto 1.3L JTD 16V Diesel		06/03 →		226		AD5800 (MLS), 0.72mm (30-029762-00)	CD5800 ▲ (21-29762-20/0)	ED5800
188 A9.000	1248	4	69.60	Direct Injection, DOHC	51/70	AD5810 (MLS), 0.82mm, 1 Hole (30-029763-00)		
Punto 1.4L		09/03 →		227		AD5820 (MLS), 0.92mm, 2 Holes (30-029764-00)		
843 A1.000	1367	4	72.00	DOHC	66-70/ 90-95			
Punto 1.4L GT Turbo		01/94 → 09/99		228		BT400 (Fibre) (30-026693-10)	DT401	ET400 GT401
176 A4.000/176 B6.000	1372	4	80.50		98/133			
Punto 1.6L 90		01/94 → 04/97		229		AY460 (Fibre) [249]	DR631 (21-27866-20/0)	ET400
Punto Convertible 1.6L 90		04/94 → 04/97				BR630 (Fibre) (30-027866-00)		GR631 [1 2] (20-27866-00/0)
176 A9.000	1581	4	86.40	EFI	65/88			

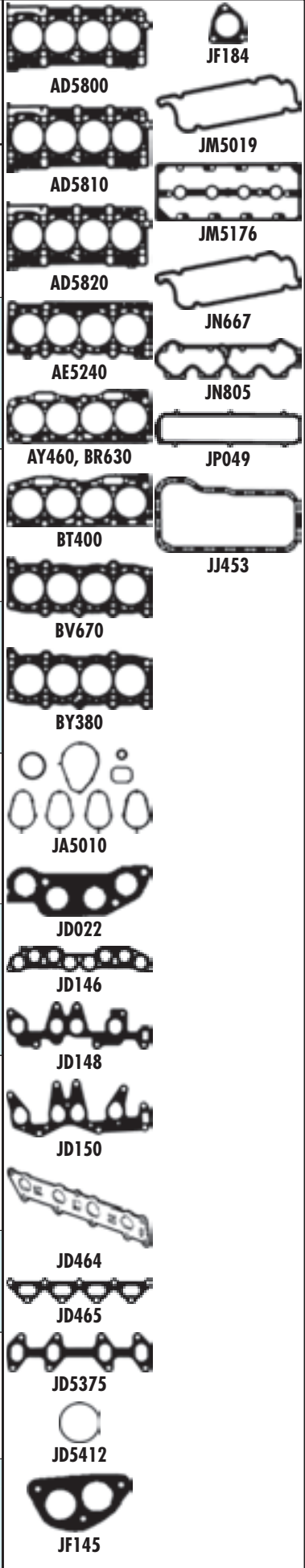
								
HBS052 ⊗ [22-17006B] M9x1.25x95mm (x10)	JA5010 ■ JD5375 ■ (x2) (31-029968-00) ⊙ JF145 (MLS)	JM5019 JM5181 (50-029843-00) (Rubber)	HR354 [94]	HR800 ■	■ NA5053 30x42x7mm, FPM (50-319488-00) ■ NB815 ■ 23x35x7mm, FPM (50-319523-00) ■ NA5061 ■ 74x88x8mm, FPM	HL5024 [245]■ KA5032 [53] LV695 [53] JR673 [11] LB177 [46]	AD5800 AD5810 AD5820 AE5240 AY460, BR630 BT400 BV670 BY380 JA5010 JD022 JD146 JD148 JD150 JD464 JD465 JD5375 JD5412 JD5412 JD5412 JD5412 JF145	JF184 JM5019 JM5176 JN667 JN805 JP049 JJ453
HBS052 ⊗ [22-17006B] M9x1.25x95mm (x10)	JD148 ■ (31-025907-10) JD5375 ■ (x2) (31-029968-00) ⊙ JF145 (MLS)	JN667 (50-026094-00)	HR354 [94]	HR599 ■ (24-31919-10/0)	■ NA5053 30x42x7mm, FPM (50-319488-00) ■ NB815 ■ 23x35x7mm, FPM (50-319523-00) ■ NA5061 ■ 74x88x8mm, FPM	KA5032 [53] LV695 [53] JR673 [11] LB177 [46]	AD5800 AD5810 AD5820 AE5240 AY460, BR630 BT400 BV670 BY380 JA5010 JD022 JD146 JD148 JD150 JD464 JD465 JD5375 JD5412 JD5412 JD5412 JD5412 JF145	JN667 JN805 JP049 JJ453
HBS052 ⊗ [22-17006B] M9x1.25x95mm (x10)	JD150 ■ JD5375 ■ (31-029968-00) ⊙ JF145 (MLS)	JN667 (50-026094-00) JN667C1 (Rubber)	HR354 [94]	HR599 ■ (24-31919-10/0)	■ NA5053 30x42x7mm, FPM (50-319488-00) ■ NB815 ■ 23x35x7mm, FPM (50-319523-00) ■ NA5061 ■ 74x88x8mm, FPM	HL5024 [245]■ JR673 [11]	AD5800 AD5810 AD5820 AE5240 AY460, BR630 BT400 BV670 BY380 JA5010 JD022 JD146 JD148 JD150 JD464 JD465 JD5375 JD5412 JD5412 JD5412 JD5412 JF145	JN667 JN805 JP049 JJ453
HBS052 ⊗ [22-17006B] M9x1.25x95mm (x10)	JD150 ■ JD5375 ■ (x2) (31-029968-00) ⊙ JF145 (MLS)	JN667 (50-026094-00)	HR354 [94]	HR599 ■ (24-31919-10/0)	■ NA5053 30x42x7mm, FPM (50-319488-00) ■ NB815 ■ 23x35x7mm, FPM (50-319523-00) ■ NA5061 ■ 74x88x8mm, FPM	HL5024 [245]■ JR673 [11]	AD5800 AD5810 AD5820 AE5240 AY460, BR630 BT400 BV670 BY380 JA5010 JD022 JD146 JD148 JD150 JD464 JD465 JD5375 JD5412 JD5412 JD5412 JD5412 JF145	JN667 JN805 JP049 JJ453
HBS247 ⊗ [22-17019B] M9x1.25x87mm (x10)	JD464 ■ JD465 ■ ⊙ JF184	JM5176 (50-029831-00)	HR354 [94]	HR814 ■ (50-319374-00)	■ NA5058 40x55x7mm, FPM ■ NA5057 ■ 27x37x7mm, FPM ■ NA5061 ■ 74x88x8mm, FPM	JR673 [11] →06/99	AD5800 AD5810 AD5820 AE5240 AY460, BR630 BT400 BV670 BY380 JA5010 JD022 JD146 JD148 JD150 JD464 JD465 JD5375 JD5412 JD5412 JD5412 JD5412 JF145	JM5176 JN667 JN805 JP049 JJ453
HBS052 ⊗ [22-17006B] M9x1.25x95mm (x10)	JD148 ■ (31-025907-10) JD5375 ■ (x2) (31-029968-00) ⊙ JF145 (MLS)	JN667 (50-026094-00)	HR354 [94]	HR599 ■ (24-31919-10/0)	■ NA5053 30x42x7mm, FPM (50-319488-00) ■ NB815 ■ 23x35x7mm, FPM (50-319523-00) ■ NA5061 ■ 74x88x8mm, FPM	KA5032 [53] LV695 [53] JR673 [11] LB177 [46]	AD5800 AD5810 AD5820 AE5240 AY460, BR630 BT400 BV670 BY380 JA5010 JD022 JD146 JD148 JD150 JD464 JD465 JD5375 JD5412 JD5412 JD5412 JD5412 JF145	JN667 JN805 JP049 JJ453
HBS353 ⊗ [22-17025B] M10x1.25x119mm (x10)	JD5411 ■ (50-030025-00) JD5412 ■ (50-030026-00) JD5413 ■ (31-030027-00) (MLS)	JM5259 (31-030023-00)		HR5088 ■ (24-31952-10/0)	■ NA5223 ■ 40x52x7mm, FPM (50-319520-00) ■ NA5230 ■ 78x100x9mm, PTFE (50-319522-00)	KK5646 [45]	AD5800 AD5810 AD5820 AE5240 AY460, BR630 BT400 BV670 BY380 JA5010 JD022 JD146 JD148 JD150 JD464 JD465 JD5375 JD5412 JD5412 JD5412 JD5412 JF145	
HBS247 ⊗ [22-17019B] M9x1.25x87mm (x10)					■ NA5058 40x55x7mm, FPM ■ NA5057 ■ 27x37x7mm, FPM ■ LK5001 ■ [3] 74x187.5x17mm, FPM (50-319456-00)		AD5800 AD5810 AD5820 AE5240 AY460, BR630 BT400 BV670 BY380 JA5010 JD022 JD146 JD148 JD150 JD464 JD465 JD5375 JD5412 JD5412 JD5412 JD5412 JF145	
HBS051 ⊗ [22-17001B] M10x1.25x98mm (x5) M10x1.25x84mm (x5)	JD022	JM654 JN805 [156] (31-026819-00) JP049 (31-026820-00)	JJ453	HR363 ■	■ NA5187 30x52x7mm, ACM (50-319492-00) ■ NB818 ■ 40x56x7mm, ACM	KT754 [11] KV122 [56]	AD5800 AD5810 AD5820 AE5240 AY460, BR630 BT400 BV670 BY380 JA5010 JD022 JD146 JD148 JD150 JD464 JD465 JD5375 JD5412 JD5412 JD5412 JD5412 JF145	JM654 JN805 JP049 JJ453
HBS051 ⊗ [22-17001B] M10x1.25x98mm (x5) M10x1.25x84mm (x5)	JD146 (31-027221-10)	JP049 (31-026820-00)	JJ453	HR363 ■	■ NA5187 30x52x7mm, ACM (50-319492-00) ■ NB818 ■ 40x56x7mm, ACM ■ NF887 ■ [3] 64x112.5x20mm, FPM (50-319393-00)	KA294 [13] KT754 [11]	AD5800 AD5810 AD5820 AE5240 AY460, BR630 BT400 BV670 BY380 JA5010 JD022 JD146 JD148 JD150 JD464 JD465 JD5375 JD5412 JD5412 JD5412 JD5412 JF145	JP049 JJ453











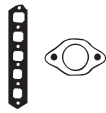

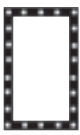

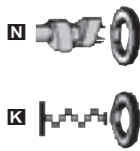









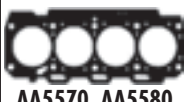





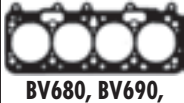



























































































FIAT



KW/PS



Punto 1.7L 16V 130 HGT					04/95 →	230	AA5420 (MLS), 0.38mm (30-029064-00)	CA5421 (21-29064-21/0)	EA5420 (22-29064-00/0)
188 A6.000	1747	4	82.00	Euro 3		96/131			
192 A4.000	1747	4	82.00	DOHC, Euro 3		96/131			
Punto 1.7L D Diesel					04/94 → 02/00	231	BT220 (Fibre), 1.65mm (30-025166-10) BT230 (Fibre), 1.80mm, 1 Notch BT240 (Fibre), 1.95mm, 2 Notches (30-025168-10)	DV680▲ (21-25142-26/0)	EV684 (22-25142-00/0) GV680▲ [100]
176 B3.000	1697	4	82.60			42/57			
Punto 1.7L TD Diesel					01/94 → 02/00	232	BR680 (Graphite), 1.65mm AC5140 (MLS), 1.66mm (30-026296-20) BV680 (Fibre), 1.67mm, 0 Notches (30-026296-10) BV690 (Fibre), 1.75mm, 1 Notch AC5150 (MLS), 1.76mm (30-026297-20) BV700 (Fibre), 1.85mm, 2 Notches (30-027859-00) BW980 (Fibre), 1.93mm, 3 Notches AC5160 (MLS), 1.96mm (30-026298-20)	DV680▲ (21-25142-26/0)	GV680▲ [100]
Punto 1.7L TD 60 Diesel					09/96 → 09/99				
146 D7.000/176 A5.000	1697	4	82.60	Turbo		46/63			
176 B7.000	1697	4	82.60	SOHC, Turbo		46/63			
176 B7.000	1697	4	82.60	SOHC		46/63			
176 A3.000	1697	4	82.60			51-53/ 69			
176 A5.000	1697	4	82.60			52/71			
Punto 1.8L 130 HGT					09/99 →	233	AY500 (Fibre) [249] 183A1.000 AA5420 (MLS), 0.38mm (30-029064-00) 188A6.000 BW720 (Fibre), 1.65mm, (Felt) (30-028382-00) 183A1.000	CA5421 (21-29064-21/0) 188A6.000 DW723■ (21-28382-23/0) 183A1.000	EA5420 (22-29064-00/0) 188A6.000 GW723 183A1.000
183 A1.000/188 A6.000	1747	4	82.00			96/131			
Punto 1.9L D 60 Diesel					02/00 →	234	BZ790 (MLS), 0.80mm (30-028707-00) BZ800 (MLS), 0.90mm, 1 Notch (30-028708-00) BZ810 (MLS), 1.00mm, 2 Notches (30-028709-00)	DZ790▲ (21-28707-20/0)	GZ790▲
Punto 1.9L DS 60 Diesel					09/99 →				
188 A3.000	1910	4	82.00			44/60			
Punto 1.9L JTD Diesel					02/00 →	235	AG7390 (MLS), 0.82mm (30-030144-00) AA5570 (MLS), 0.92mm, 1 Hole (30-029094-10) AA5580 (MLS), 1.02mm, 2 Holes (30-029095-10)	CA5560▲ (21-29093-21/0) CA5561▲ (21-29093-20/0) Eng.4081111 →	FA5560▲ (20-29095-00/0)
Punto 1.9L JTD 80 Diesel					09/99 →				
188 A2.000/188 A7.000	1910	4	82.00	Direct Injection		73/99			
Punto 1.9L JTD Diesel					06/03 →	236	AG7390 (MLS), 0.82mm (30-030144-00) AA5570 (MLS), 0.92mm, 1 Hole (30-029094-10) AA5580 (MLS), 1.02mm, 2 Holes (30-029095-10)	CA5560▲ (21-29093-21/0) CA5561▲ (21-29093-20/0) Eng.4081111 →	EE5181 (22-29832-01/0)
188 B2.000	1910	4	82.00	Direct Injection, SOHC		74/100			
Qubo 1.3L D Multijet Diesel					09/08 →	237		CD5810▲	ED5810 FD5810
199 A2.000	1248	4	69.60	Direct Injection, DOHC		55/75			











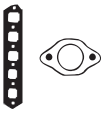

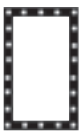

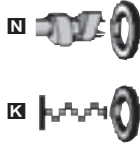

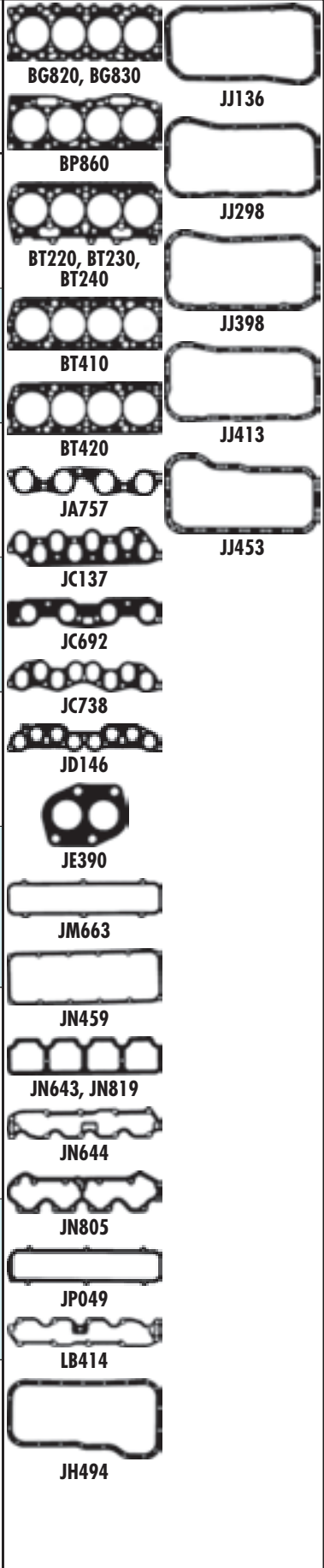





















































      							
HBS132  [22-17015B] M10x1.25x254mm (x10)	JD271  (31-027450-10) (Metal) JD273  (31-027729-00) (MLS)	HL701  [24-28782-00/0]		HR800 	NA5053 30x42x7mm, FPM (50-319488-00) NA5069 55x68x8mm, FPM (50-319515-00) NA5070  31x41x7mm, FPM (50-319524-00) NF888  [3] 93x139.7x12mm, FPM (50-319526-00)	HL5030 [245]  KA845 [13] JS069 [45]	 AA5420, BW720  AA5570, AA5580  AC5140, AC5150, AC5160  AY500  BR680  BT220, BT230, BT240  BV680, BV690, BV700, BW980  BZ790, BZ800, BZ810  JA5008  JA5011  JA5035  JC738  JD271  JD273  JD468  JD580  HL701  JM5003  JM5028
HBS095  [22-17007B] M12x1.25x133mm (x10)	JC738 (31-026290-10)	JN459 (31-025142-10)	JJ298 (Cork) (Rubber) JJ398 (31-027379-00)	HR596 	NA5187 30x52x7mm, ACM (50-319492-00) NB742  30x43x8mm, ACM (50-319408-00) NB732  74x90x10mm, FPM NA5062  74x90x10mm, ACM	LV583 [53]	 JM5204  JN459  JJ298  JJ398  JJ535
HBS095  [22-17007B] M12x1.25x133mm (x10)	JC738 (31-026290-10)	JN459 (31-025142-10)	JJ298 JJ398 (31-027379-00)	HR596 	NA5187 30x52x7mm, ACM (50-319492-00) NB742  30x43x8mm, ACM (50-319408-00) NB732  74x90x10mm, FPM NA5062  74x90x10mm, ACM	LV583 [53] LT498 [45]	 JM5204  JN459  JJ298  JJ398  JJ535
HBS132  [22-17015B] M10x1.25x254mm (x10)	JD271  (31-027450-10) (Metal) JD273  (31-027729-00) (MLS)	HL701  [24-28782-00/0]	JJ535 (31-028781-00)	HR800 	NA5053 30x42x7mm, FPM (50-319488-00) NA5069 55x68x8mm, FPM (50-319515-00) NA5070  31x41x7mm, FPM (50-319524-00) NF888  [3] 93x139.7x12mm, FPM (50-319526-00)	HL5030 [245]  HJ283 [39]  JS069 [45]	 JA5008  JA5011  JA5035  JC738  JD271  JD273  JD468  JD580  HL701  JM5003  JM5028
HBS227  [22-17018B] M12x1.25x218mm (x10)	JA5008  (31-029958-00) (Rubber) (Rubber) JA5011  (31-029959-00) (Rubber) JD468  (31-028377-00) (MLS)	JM5003 (50-029960-00)		HR363 	NA5053 30x42x7mm, FPM (50-319488-00) NA5070  31x41x7mm, FPM (50-319524-00) NF888  [3] 93x139.7x12mm, FPM (50-319526-00)	HL5031 [245]  KA845 [13] KK5004 [155]	 JM5003  JM5028  JA5008  JA5011  JA5035  JC738  JD271  JD273  JD468  JD580  HL701 JM5003 JM5028
HBS227  [22-17018B] M12x1.25x218mm (x10)	JA5035  (31-029407-00) JD580  JD468  (31-028377-00) (MLS)	JM5028 (31-029635-00) →Eng.4081110 JM5204 (50-029935-00) Eng.4081111 →		HR363 	NA5053 30x42x7mm, FPM (50-319488-00) NA5070  31x41x7mm, FPM (50-319524-00) NF888  [3] 93x139.7x12mm, FPM (50-319526-00)	HL5031 [245]  KL476 [70] JR5001 [11]	 JM5003  JM5028  JA5008  JA5011  JA5035  JC738  JD271  JD273 JD468 JD580 HL701 JM5003 JM5028
HBS227  [22-17018B] M12x1.25x218mm (x10)	JA5035  (31-029407-00) JD580  JD468  (31-028377-00) (MLS)	JM5028 (31-029635-00) →Eng.4081110 JM5204 (50-029935-00) Eng.4081111 →		HR363 	NA5053 30x42x7mm, FPM (50-319488-00) NA5070  31x41x7mm, FPM (50-319524-00) NF888  [3] 93x139.7x12mm, FPM (50-319526-00)	HL5031 [245] 	 JM5003  JM5028  JA5008  JA5011  JA5035  JC738  JD271 JD273 JD468 JD580 HL701 JM5003 JM5028



KW/PS



Regata 1.3L 70				09/83 → 07/89	238		DJ851▲ DP871 (21-25894-22/0) → Eng.5750056	GP871 (20-25894-03/0) → Eng.5750056
138 B2.000	1302	4	86.40	SOHC	50/68			
149 A3.000/149 A7.000	1302	4	86.40		50/68			
Regata 1.5L 85				05/85 → 12/87	239	BP860 (Fibre) (30-025893-10)	DP860 (21-25893-23/0)	GP861 (20-25893-02/0)
149 A5.000	1498	4	86.40	i.e., SOHC	55/75			
Regata 1.5L 85 Super				09/83 → 04/85	240	BP860 (Fibre) (30-025893-10)	DP860 (21-25893-23/0) DP870 (21-25894-23/0)	GP861 (20-25893-02/0)
138 B3.000	1498	4	86.40		55-61/ 75-83			
Regata 1.5L i.e. 75				12/86 → 07/89	241	BP860 (Fibre) (30-025893-10) 01/86 → Eng.5771240 →	DP860 (21-25893-23/0) 01/86 → Eng.5771240 →	GP861 (20-25893-02/0)
138 C2.048	1498	4	86.40	i.e., SOHC	55/75			
Regata 1.5L i.e. 75				07/85 → 07/89	242	BP860 (Fibre) (30-025893-10) Eng.5750056 →	DJ851▲ Eng.5750056 → DP861 (21-25893-22/0) Eng.5750056 →	GP861 (20-25893-02/0)
138 C2.048	1498	4	86.40	i.e., SOHC	55/75			
149 C1.000	1498	4	86.40	SOHC	55/75			
Regata 1.6L 100				09/84 → 12/86	243	BT410 (Fibre) BT420 (Fibre) (30-025413-10)	DP68A	
149 A4.000	1585	4	84.00		74/100			
Regata 1.7L D 60 Diesel				01/84 → 12/89	244	BT220 (Fibre), 1.65mm (30-025166-10) BT230 (Fibre), 1.80mm, 1 Notch BT240 (Fibre), 1.95mm, 2 Notches (30-025168-10)	DV680▲ (21-25142-26/0)	EV684 (22-25142-00/0) GV680▲ [100]
149 B3.000	1697	4	82.60	SOHC	42/57			
Regata 1.7L D 60 Diesel				09/83 → 12/86	245	BG820 (Fibre), 1.80mm, 1 Notch (30-024360-10) BG830 (Fibre), 1.95mm, 2 Notches (30-024361-10)	DG811▲ (21-25298-21/0)	GG811▲ (20-25298-01/0)
138 B6.000	1714	4	83.00		43/58			
Regata 1.9L D 65 Diesel				04/84 → 07/89	246	BT220 (Fibre), 1.65mm (30-025166-10) BT230 (Fibre), 1.80mm, 1 Notch BT240 (Fibre), 1.95mm, 2 Notches (30-025168-10)	DV680▲ (21-25142-26/0)	EV684 (22-25142-00/0) GV680▲ [100]
149 A1.000	1929	4	82.60		48/65			











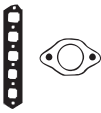

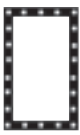

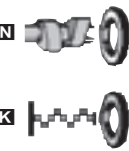































































































								
HBS051  (22-17001B) M10x1.25x98mm (x5) M10x1.25x84mm (x5)	JD146 (31-027221-10)  JE390 (31-021632-10)	JM654 JN805 [156] (31-026819-00) JP049 (31-026820-00)	JJ453 → Eng.9508753	HR596 	 NA5187 30x52x7mm, ACM (50-319492-00)  NB818 40x56x7mm, ACM  NA5049 64x80x8mm, ACM	KA293 [13] KA294 [13]	BG820, BG830 BP860 BT220, BT230, BT240 BT410 BT420 JA757 JC137 JC692 JC738 JD146  JE390 JM663 JN459 JN643, JN819 JN644 JN805 JP049 LB414 JH494	JJ136 JJ298 JJ398 JJ413 JJ453
HBS051  (22-17001B) M10x1.25x98mm (x5) M10x1.25x84mm (x5)	JD146 (31-027221-10)  JE390 (31-021632-10)	JM654 JM663 (31-024732-00) JN805 [156] (31-026819-00)	JH494 (31-022554-00)	HR596 	 NA5187 30x52x7mm, ACM (50-319492-00)  NB818 40x56x7mm, ACM  NA5049 64x80x8mm, ACM	KA293 [13] KA294 [13] KT465 [54]	BT410 BT420 JA757 JC137 JC692 JC738 JD146  JE390 JM663 JN459 JN643, JN819 JN644 JN805 JP049 LB414 JH494	JJ398 JJ413 JJ453
HBS051  (22-17001B) M10x1.25x98mm (x5) M10x1.25x84mm (x5)	JD146 (31-027221-10)  JE390 (31-021632-10)	JM654 JM663 (31-024732-00) JN805 [156] (31-026819-00)	JH494 (31-022554-00)	HR596 	 NA5187 30x52x7mm, ACM (50-319492-00)  NB818 40x56x7mm, ACM  NA5049 64x80x8mm, ACM	KA293 [13] KA294 [13] KT465 [54]	BT420 JA757 JC137 JC692 JC738 JD146  JE390 JM663 JN459 JN643, JN819 JN644 JN805 JP049 LB414 JH494	JJ413 JJ453
HBS051  (22-17001B) M10x1.25x98mm (x5) M10x1.25x84mm (x5)	JD146 (31-027221-10)  JE390 (31-021632-10)	JM654 JM663 (31-024732-00) JN805 [156] (31-026819-00)	JH494 (31-022554-00)	HR596 	 NA5187 30x52x7mm, ACM (50-319492-00)  NB818 40x56x7mm, ACM  NA5049 64x80x8mm, ACM	HJ279 [39] [48]  KT465 [54] KV122 [56]	JC137 JC692 JC738 JD146  JE390 JM663 JN459 JN643, JN819 JN644 JN805 JP049 LB414 JH494	JJ279 [39] [48]  KT465 [54] KD717 [91] KV122 [56]
HBS051  (22-17001B) M10x1.25x98mm (x5) M10x1.25x84mm (x5)	JD146 (31-027221-10)  JE390 (31-021632-10)	JM654 JN805 [156] (31-026819-00) JP049 (31-026820-00)	JJ453	HR596 	 NA5187 30x52x7mm, ACM (50-319492-00)  NB818 40x56x7mm, ACM  NA5049 64x80x8mm, ACM	KA294 [13] HJ279 [39] [48]  KT465 [54] KD717 [91] KV122 [56]	JC137 JC692 JC738 JD146  JE390 JM663 JN459 JN643, JN819 JN644 JN805 JP049 LB414 JH494	JJ453
HBS051  (22-17001B) M10x1.25x98mm (x5) M10x1.25x84mm (x5)	JC692  (31-027314-00) JA757  (31-022346-10)	JN643 (x2) (31-027225-00) JN819 (x2) JN644  (31-025140-10) LB414  [156]	JJ413 (31-027315-00)	HR363 	 NA5187 30x52x7mm, ACM (50-319492-00)	KT465 [54] LS649 [46]	JC692 JC738 JD146  JE390 JM663 JN459 JN643, JN819 JN644 JN805 JP049 LB414 JH494	
HBS095  (22-17007B) M12x1.25x133mm (x10)	JC738 (31-026290-10)	JN459 (31-025142-10)	JJ298 (Cork) (Rubber) JJ398 (31-027379-00)	HR596 	 NA5187 30x52x7mm, ACM (50-319492-00)  NB742 30x43x8mm, ACM (50-319408-00)  NB732 74x90x10mm, FPM  NA5062 74x90x10mm, ACM	KA556 [13] LT021 [13] [164] LT023 [13] LV583 [53] KT465 [54] LT019 [86] KT639 [11] LT498 [45]	JN459 JN643, JN819 JN644 JN805 JP049 LB414 JH494	
	JC137 (31-024682-10)		JJ136 (31-024680-00)	HR596 	 NA5187 30x52x7mm, ACM (50-319492-00)  NA5062 74x90x10mm, ACM  NB818 40x56x7mm, ACM  NB732 74x90x10mm, FPM	KA556 [13] LT021 [13] [164] LT023 [13] KT465 [54] LT019 [86] KT639 [11]	JN459 JN643, JN819 JN644 JN805 JP049 LB414 JH494	
HBS095  (22-17007B) M12x1.25x133mm (x10)	JC738 (31-026290-10)	JN459 (31-025142-10)	JJ298 (Cork) (Rubber) JJ398 (31-027379-00)	HR596 	 NA5187 30x52x7mm, ACM (50-319492-00)  NB742 30x43x8mm, ACM (50-319408-00)  NB732 74x90x10mm, FPM  NA5062 74x90x10mm, ACM	KA556 [13] LT021 [13] [164] LT023 [13] LV583 [53] KT465 [54] LT019 [86] KT639 [11] LT498 [45]	JN459 JN643, JN819 JN644 JN805 JP049 LB414 JH494	



KW/PS



Model	Year Range	CC	Cyls	Stroke	SOHC	Power (KW/PS)	Parts	Accessories	
Regata 1.9L TD 80 Diesel	05/86 → 07/89	1929	4	82.60		247 62/84	BR680 (Graphite), 1.65mm BV680 (Fibre), 1.67mm, 0 Notches (30-026296-10) BR690 (Graphite), 1.80mm, 1 Notch (30-025167-10) BR700 (Graphite), 1.95mm, 2 Notches (30-026298-10)	DT290▲ (21-25950-21/0)	GV680▲ [100]
Ritmo 1.1L 60	04/85 → 12/87	1116	4	80.00	SOHC	248 41/55	BJ850 (Fibre) (30-024779-10)	DJ851▲ DJ852 (21-24779-21/0)	GJ852
Ritmo 1.1L 60/60S	01/83 →					249	BJ850 (Fibre) (30-024779-10)	DJ851▲ DJ852 (21-24779-21/0)	GJ852
Ritmo 1.3L 65	01/78 → 09/82	1302	4	86.40		250 48/65	BP110 (Fibre) (30-024119-10)	DJ851▲ DP110 DP870 (21-25894-23/0)	
Ritmo 1.3L 70	01/83 → 08/85	1302 149 A3.000/149 A7.000	4 4	86.40 86.40	SOHC	251 50/68 50/68		DJ851▲ DP871 (21-25894-22/0) → Eng.5750056	GP871 (20-25894-03/0) → Eng.5750056
Ritmo 1.3L 75	01/81 → 09/82	1302	4	86.40		252 55/75	BP110 (Fibre) (30-024119-10)	DJ851▲ DP110	
Ritmo 1.5L '75	09/85 → 12/88	1498 1498	4 4	86.40 86.40	i.e., SOHC SOHC	253 55/75 55/75	BP860 (Fibre) (30-025893-10)	DP860 (21-25893-23/0)	GP861 (20-25893-02/0)
Ritmo 1.5L 85	01/83 → 12/87	1498	4	86.40		254 55-61/ 75-83	BP860 (Fibre) (30-025893-10) 01/86 → Eng.5771240 →	DJ851▲ DP870 (21-25894-23/0) DP861 (21-25893-22/0) 01/86 → Eng.575056 →	GP861 (20-25893-02/0)
Ritmo 1.5L 85	01/80 → 07/89	1498	4	86.40		255 63/86	BP110 (Fibre) (30-024119-10)	DP110 01/79 → 06/82 → Eng.4525272	
Ritmo 1.5L 85	08/85 → 05/87	1498	4	86.40	i.e., SOHC	256 55/75	BP860 (Fibre) (30-025893-10)	DP860 (21-25893-23/0)	GP861 (20-25893-02/0)
Ritmo 1.5L i.e. 75	10/85 → 05/87	1498 1498	4 4	86.40 86.40	i.e., SOHC SOHC	257 55/75 55/75	BP860 (Fibre) (30-025893-10) 01/86 → Eng.5771240 →	DJ851▲ DP861 (21-25893-22/0) 01/86 → Eng.575056 →	GP861 (20-25893-02/0)











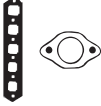

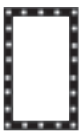

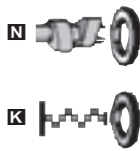























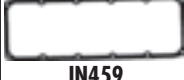































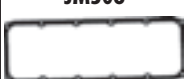
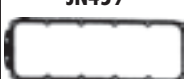



















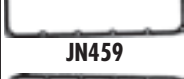



								
HBS095  (22-17007B) M12x1.25x133mm (x10)	JC738 (31-026290-10)	JN568 (31-025950-10)	JJ298 (Cork) (Rubber) JJ398 (31-027379-00)	HR596 	 NA5187 30x52x7mm, ACM (50-319492-00)  NB732 74x90x10mm, FPM  NB742 30x43x8mm, ACM (50-319408-00)  NA5062 74x90x10mm, ACM	LT021 [13] [164] LT023 [13] LV583 [53] KT465 [54] LT019 [86] KT639 [11] LT498 [45] LV582 [45] LV585 [45]	 BJ850  BP110  BP860  BR680, BR690, BR700	
HBS051  (22-17001B) M10x1.25x98mm (x5) M10x1.25x84mm (x5)	JD146 (31-027221-10)	JM654 JN805 [156] (31-026819-00) JP049 (31-026820-00)	JJ453	HR596 	 NA5187 30x52x7mm, ACM (50-319492-00)  NB818  40x56x7mm, ACM  NA5049  64x80x8mm, ACM	KA293 [13] KA294 [13] KH029 [53]	 BV680  JC738  JD146  JE390	
HBS051  (22-17001B) M10x1.25x98mm (x5) M10x1.25x84mm (x5)	JD146 (31-027221-10)	JN805 [156] (31-026819-00) JP049 (31-026820-00)	JJ453		 NA5187 30x52x7mm, ACM (50-319492-00)  NB818  40x56x7mm, ACM  NA5049  64x80x8mm, ACM	KA293 [13] KA294 [13] KT465 [54] KD717 [91]	 JE390	
HBS051  (22-17001B) M10x1.25x98mm (x5) M10x1.25x84mm (x5)	JD146 (31-027221-10)  JE390  (31-021632-10)	JM654 JM663 (31-024732-00) JN805 [156] (31-026819-00)	JH494 (31-022554-00)		 NA5187 30x52x7mm, ACM (50-319492-00)  NB818  40x56x7mm, ACM  NA5049  64x80x8mm, ACM	KA293 [13] KA294 [13] KA354 [13]	 JM663	
HBS051  (22-17001B) M10x1.25x98mm (x5) M10x1.25x84mm (x5)	JD146 (31-027221-10)  JE390  (31-021632-10)	JM654 JN805 [156] (31-026819-00) JP049 (31-026820-00)	JJ453	HR596 	 NA5187 30x52x7mm, ACM (50-319492-00)  NB818  40x56x7mm, ACM  NA5049  64x80x8mm, ACM	KA294 [13] HJ279 [39] [48]  KT465 [54] KT758 [46]	 JN568  JN805	
HBS051  (22-17001B) M10x1.25x98mm (x5) M10x1.25x84mm (x5)	JD146 (31-027221-10)  JE390  (31-021632-10)	JM654 JM663 (31-024732-00) JN805 [156] (31-026819-00)	JH494 (31-022554-00)	HR596 	 NA5187 30x52x7mm, ACM (50-319492-00)  NB818  40x56x7mm, ACM  NA5049  64x80x8mm, ACM	KA293 [13] KA294 [13] KA354 [13]	 JP049	
HBS051  (22-17001B) M10x1.25x98mm (x5) M10x1.25x84mm (x5)					 NA5187 30x52x7mm, ACM (50-319492-00)  NB818  40x56x7mm, ACM  NA5049  64x80x8mm, ACM	KA294 [13]	 JH494	
HBS051  (22-17001B) M10x1.25x98mm (x5) M10x1.25x84mm (x5)	JD146 (31-027221-10)	JM654 JM663 (31-024732-00) JN805 [156] (31-026819-00)	JH494 (31-022554-00)	HR596 	 NA5187 30x52x7mm, ACM (50-319492-00)  NB818  40x56x7mm, ACM  NA5049  64x80x8mm, ACM	KA294 [13] HJ279 [39] [48]  KT465 [54] KV122 [56]	 JJ298  JJ398	
HBS051  (22-17001B) M10x1.25x98mm (x5) M10x1.25x84mm (x5)	JD146 (31-027221-10)  JE390  (31-021632-10)	JM654 JM663 (31-024732-00) JN805 [156] (31-026819-00)	JH494 (31-022554-00)	HR596 	 NA5187 30x52x7mm, ACM (50-319492-00)  NB818  40x56x7mm, ACM  NA5049  64x80x8mm, ACM	KA294 [13] HJ277 [39]  KT465 [54] KD717 [91]	 JJ298  JJ398  JJ453	
HBS051  (22-17001B) M10x1.25x98mm (x5) M10x1.25x84mm (x5)	JD146 (31-027221-10)	JM654 JM663 (31-024732-00) JN805 [156] (31-026819-00)	JH494 (31-022554-00)	HR596 	 NA5187 30x52x7mm, ACM (50-319492-00)  NB818  40x56x7mm, ACM  NA5049  64x80x8mm, ACM	KA293 [13] KA294 [13] KT465 [54] KT754 [11] KT756 [11]		
HBS051  (22-17001B) M10x1.25x98mm (x5) M10x1.25x84mm (x5)	JD146 (31-027221-10)	JM654 JM663 (31-024732-00) JN805 [156] (31-026819-00)	JH494 (31-022554-00)	HR596 	 NA5187 30x52x7mm, ACM (50-319492-00)  NB818  40x56x7mm, ACM  NA5049  64x80x8mm, ACM	KA294 [13] HJ279 [39] [48]  KT465 [54] KV122 [56]		



KW/PS



Ritmo 1.6L 105		01/83 → 12/87		258		BK540 (Fibre)		DK541		GK541	
Ritmo 1.6L i.e. 90		12/85 → 12/87									
138 AR.000	1585	4	84.00		74/100						
Ritmo 1.6L 105 Sport		05/81 → 12/82		259		BK540 (Fibre)		DK541 DP133		GK541	
138 AR.000	1585	4	84.00		74/100						
Ritmo 1.7L D 55 Diesel		10/79 → 09/82		260		BG820 (Fibre), 1.80mm, 1 Notch (30-024360-10) BG830 (Fibre), 1.95mm, 2 Notches (30-024361-10)					
	1714	4			43/58						
Ritmo 1.7L D 60 Diesel		05/85 → 12/87		261		BT220 (Fibre), 1.65mm (30-025166-10) BT230 (Fibre), 1.80mm, 1 Notch BT240 (Fibre), 1.95mm, 2 Notches (30-025168-10)		DV680▲ (21-25142-26/0)		GV680▲ [100]	
149 B3.000	1697	4	82.60	SOHC	42/57						
138 C.000	1698	4	86.40	Indirect Injection, SOHC	44/60						
Ritmo 1.7L D 60 Diesel		10/82 → 10/85		262		BG820 (Fibre), 1.80mm, 1 Notch (30-024360-10) BG830 (Fibre), 1.95mm, 2 Notches (30-024361-10)		DG811▲ (21-25298-21/0)		GG811▲ (20-25298-01/0)	
138 B6.000	1714	4	83.00		43/58						
Ritmo 1.7L D 55 Diesel		10/79 → 09/82		263		BG820 (Fibre), 1.80mm, 1 Notch (30-024360-10)					
138 A5.000	1714	4	83.00	Indirect Injection, SOHC	40-43/ 55-58						
Ritmo 1.9L TD 80 Diesel		12/85 → 12/87		264		BR680 (Graphite), 1.65mm BV680 (Fibre), 1.67mm, 0 Notches (30-026296-10) BR690 (Graphite), 1.80mm, 1 Notch (30-025167-10) BR700 (Graphite), 1.95mm, 2 Notches (30-026298-10)		DT290▲ (21-25950-21/0)			
831 D1.000	1929	4	82.60		62/84						
Scudo 1.6L		02/96 →		265		AY460 (Fibre) [249] BR630 (Fibre) (30-027866-00)		DR630 (21-26294-21/0) → 12/93 DR632 (21-27866-21/0) 01/93 →		GR632 (20-27866-01/0)	
220 A 2.000	1581	4	86.40	EFI, SOHC	55/75						
Scudo 1.6L B EL		06/92 → 08/96		266		AY460 (Fibre) [249] BR630 (Fibre) (30-027866-00)		DR630 (21-26294-21/0)		GR630 (20-26294-01/0)	
835 C1.000	1581	4	86.40	SOHC	55-57/ 75-78						

								
		JA777  (31-022714-10) (Graphite) JA757  (31-022346-10) 	JM085 (x2) (31-021753-00) JM508 [156] (31-021852-60)	JH111 (31-023475-00)	HR363 	 NA5187 30x52x7mm, ACM (50-319492-00)  NB818 40x56x7mm, ACM  NA5050 70x90x10mm, ACM	KT465 [54] KT639 [11] LS649 [46]	 AY460, BR630  BG820, BG830  BK540  BR680, BR690, BR700  BT220, BT230, BT240  BV680  JA757  JA777  JC137  JC693  JC738  JD146  JE388  JF150  JM085  JM508  JN459  JN568  JN805  JP049
		JA777  (31-022714-10) (Graphite) JC693  JA757  (31-022346-10) 	JM085 (x2) (31-021753-00) JM508 [156] (31-021852-60)	JH111 (31-023475-00)	HR363 	 NA5187 30x52x7mm, ACM (50-319492-00)  NB818 40x56x7mm, ACM  NA5050 70x90x10mm, ACM	KT465 [54] KT639 [11] LS649 [46]	 JH111  JJ136  JJ298  JJ398  JJ453
HBS095  (22-17007B) M12x1.25x133mm (x10)	JC738 (31-026290-10)	JN459 (31-025142-10)	JJ298 (Cork) (Rubber) JJ398 (31-027379-00)	HR596 	 NA5187 30x52x7mm, ACM (50-319492-00)  NB742 30x43x8mm, ACM (50-319408-00)  NB732 74x90x10mm, FPM  NA5062 74x90x10mm, ACM	KA556 [13] LT021 [13][164] LT023 [13] LV583 [53] KT465 [54] LT019 [86] LT498 [45]	 JA757  JA777  JC137  JC693  JC738  JD146  JE388  JF150  JM085  JM508  JN459  JN568  JN805  JP049	
	JC137 (31-024682-10)		JJ136 (31-024680-00)	HR596 	 NA5187 30x52x7mm, ACM (50-319492-00)  NB818 40x56x7mm, ACM  NB732 74x90x10mm, FPM  NA5062 74x90x10mm, ACM	KA556 [13] LT021 [13][164] LT023 [13] KT465 [54] LT019 [86] KT639 [11]		
HBS095  (22-17007B) M12x1.25x133mm (x10)	JC738 (31-026290-10)	JN568 (31-025950-10)	JJ298 (Cork) (Rubber) JJ398 (31-027379-00)	HR596 	 NA5187 30x52x7mm, ACM (50-319492-00)  NB742 30x43x8mm, ACM (50-319408-00)  NB732 74x90x10mm, FPM  NA5062 74x90x10mm, ACM	LT021 [13][164] LT023 [13] LV583 [53] KT465 [54] LT019 [86] KT639 [11] LT498 [45] LV582 [45] LV585 [45]	 JE388  JF150  JM085  JM508  JN459  JN568  JN805  JP049	
HBS092  (22-17003B) M10x1.25x115mm (x10) →12/93 HBS051  (22-17001B) M10x1.25x98mm (x5) M10x1.25x84mm (x5) 01/93→	JD146 (31-027221-10)  JF150 (31-027151-00)	JN805 [156] (31-026819-00) JP049 (31-026820-00)	JJ453	HR363 	 NA5187 (x2) 30x52x7mm, ACM (50-319492-00)  NB818 40x56x7mm, ACM  NF887 [3] 64x112.5x20mm, FPM (50-319393-00)	KA293 [13] KA294 [13] KA354 [13] LA378 [53] KT465 [54] KT754 [11] KT756 [11] LR902 [11]		
HBS051  (22-17001B) M10x1.25x98mm (x5) M10x1.25x84mm (x5)	JD146 (31-027221-10)	JP049 (31-026820-00)	JJ453	HR363 	 NA5187 (x2) 30x52x7mm, ACM (50-319492-00)  NB818 40x56x7mm, ACM	KT754 [11]		



KW/PS



Scudo 1.9L D Diesel				02/96 → 04/02	267			DJ720▲	EL890
D9B (XUD9/A/B/L/Y)	1905	4	83.00		49/67	BX880 (Fibre), 1.36mm, 1 Notch (30-028475-00) →0.56 →0.67mm BX890 (Fibre), 1.40mm, 2 Notches (30-028476-00) →0.68 →0.71mm BX900 (Fibre), 1.44mm, 3 Notches (30-028477-00) →0.72 →0.75mm BX910 (Fibre), 1.48mm, 4 Notches (30-028478-00) →0.76 →0.79mm BX920 (Fibre), 1.52mm, 5 Notches (30-028479-00) →0.80 →0.83mm		(21-25202-22/0)	EL890 (22-25198-01/0) GJ720▲ (20-25202-02/0)
XUD9 (D9B/ DJZ/ 162)	1905	4	83.00						
Scudo 1.9L D Diesel				04/98 →	268			CA5830▲	EA5830
WJZ (DW8)	1868	4	82.20	SOHC	51/69	AA5830 (Steel Elastomer), 1.26mm, 1 Hole (30-029190-00) →0.51 →0.54mm AA5840 (Steel Elastomer), 1.30mm, 2 Holes (30-029191-00) →0.55 →0.58mm AA5850 (Steel Elastomer), 1.34mm, 3 Holes (30-029192-00) →0.59 →0.62mm AA5860 (Steel Elastomer), 1.38mm, 4 Holes (30-029193-00) →0.63 →0.66mm AA5870 (Steel Elastomer), 1.42mm, 5 Holes (30-029194-00) →0.67 →0.70mm AA5880 (Steel Elastomer), 1.46mm, 6 Holes (30-029195-00) →0.71 →0.75mm		(21-29482-20/0)	EA5830
Scudo 1.9L TD Diesel				02/96 →	269			DJ720▲	EL890
Scudo 1.9L TD Eco Diesel				02/96 →					
D8B	1905	4	83.00	SOHC, Turbo	66/89	BX930 (Steel Elastomer), 1.36mm, 1 Notch (30-028503-00) BX940 (Steel Elastomer), 1.40mm, 2 Notches (30-028504-00) BX950 (Steel Elastomer), 1.44mm, 3 Notches (30-028505-00) BX960 (Steel Elastomer), 1.48mm, 4 Notches (30-028506-00) BX970 (Steel Elastomer), 1.52mm, 5 Notches (30-028507-00) BX980 (Steel Elastomer), 1.59mm →0.83mm →		(21-25202-22/0)	EL890 (22-25198-01/0) GJ720▲ (20-25202-02/0)
D8B	1905	4	83.00	SOHC	66/89				
XUD9TF/L (DHX)	1905	4	83.00	SOHC, Turbo	66/89				
XUD9TF/L (DHX)	1905	4	83.00	SOHC	66/89				
Scudo 1.9L TD Diesel				04/98 → 04/02	270			DJ720▲	EL890
Scudo 1.9L TD Eco Diesel				04/98 → 04/02					
XUD9TF (DHV/ DHW)	1905	4	83.00	Turbo		BX930 (Steel Elastomer), 1.36mm, 1 Notch (30-028503-00) BX940 (Steel Elastomer), 1.40mm, 2 Notches (30-028504-00) BX950 (Steel Elastomer), 1.44mm, 3 Notches (30-028505-00) BX960 (Steel Elastomer), 1.48mm, 4 Notches (30-028506-00) BX970 (Steel Elastomer), 1.52mm, 5 Notches (30-028507-00) BX980 (Steel Elastomer), 1.59mm →0.83mm →		(21-25202-22/0)	EL890 (22-25198-01/0) GJ720▲ (20-25202-02/0)
Scudo 2.0L D Multijet Diesel				01/07 →	271			CD5500▲	ED5500
RHK/RHR	1997	4	85.00	Direct Injection, DOHC					

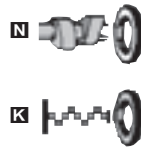
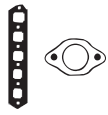

AA5830, AA5840,
AA5850, AA5860,
AA5870, AA5880



BX880, BX890,
BX900, BX910,
BX920



BX930, BX940,
BX950, BX960,
BX970, BX980



JC423



JC759



JC991



JN544



JJ283



KW/PS



Scudo 2.0L JTD Diesel 01/04 → 272								EA5830
DW10 (RHX)	1998	4	85.00	Direct Injection, SOHC	69/93			
Scudo 2.0L 09/02 → 273						AD5300 (MLS)	CD5300	
Scudo 2.0L 16V 06/00 →								
EW10J4 (RFN)	1998	4	85.00	DOHC	100/136			
Scudo 2.0L JTD Diesel 12/99 → 274								EA5830
DW10 (RHZ)	1998	4	85.00	Common Rail, SOHC	66/89			
Scudo 2.0L JTD Diesel 12/99 → 275						AC5011 (MLS), 1.30mm, 1 Hole -0.47 → -0.605mm	CC5010▲ (21-29484-20/0)	EA5830
Scudo 2.0L JTD Combinato Diesel 12/99 →						AC5020 (MLS), 1.35mm, 2 Holes (30-029478-00) -0.605 → -0.655mm		
DW10 (RHX)	1998	4	85.00	Direct Injection, SOHC	69/93	AC5031 (MLS), 1.40mm, 3 Holes (30-029479-10) -0.655 → -0.705mm		
DW10ATED4 (RHS)	1998	4	85.00	Common Rail, DOHC, Turbo	80/109	AC5040 (MLS), 1.45mm, 4 Holes (30-029480-00) -0.705 → -0.755mm		
						AC5051 (MLS), 1.50mm, 5 Holes (30-029481-10) -0.755 → -0.83mm		
Scudo 2.0L JTD Diesel 12/02 → 276						AD5490 (MLS), 1.25mm (30-029789-00)		EA5830
DW10 (RHZ)	1998	4	85.00	Common Rail, SOHC	66/89	AD5500 (MLS), 1.30mm (30-029790-00)		
						AD5510 (MLS), 1.35mm (30-029791-00)		
						AD5520 (MLS), 1.40mm (30-029792-00)		
Sedici 1.9L D Multijet Diesel 06/06 → 277								
D19AA	1910	4	82.00	Direct Injection, SOHC	88/120			
Seicento Elektra 01/99 → 278						AD5300 (MLS)		
		0			30/41	RFN		
Seicento 0.9L 01/98 → 279						AY430 (Fibre) (30-028975-00)	DT260 (21-27165-20/0)	GT260 [158] (20-27165-00/0)
1170 A1.046	899	4	65.00	SOHC	30/41	BT260 (Fibre) (30-027165-10)		
Seicento 1.1L 01/98 → 280						BP280 (Fibre), 1.65mm (30-026046-30)	CV940 [170] (21-28799-21/0)	GP285
176 B2.000	1108	4	70.00	SPI	40/54	BV940 (Fibre), 2.00mm (30-028799-00)	DV675 (21-27185-00/0)	
Seicento 1.1L 01/98 → 281						BP280 (Fibre), 1.65mm (30-026046-30)	DP286	GP286
176 B2.000	1108	4	70.00	SPI	40/54	BV940 (Fibre), 2.00mm (30-028799-00)	DV675 (21-27185-00/0)	
187 A1.000	1108	4	70.00	Injection, SOHC	40/54		DP289 <input type="checkbox"/> Eng.2533528 → Eng.2888158 →	
Siena 1.0L 09/98 → 282						BJ850 (Fibre) (30-024779-10)		
	994	4			45/61			











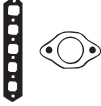

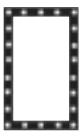

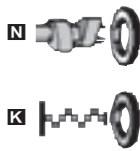



























































































							 AC5020, AC5040 AD5490, AD5500, AD5510, AD5520 AY430, BT260 BJ850 BP280, BV940 JA5010 JC973 JD148 JD536 JD5375 JD539 JF145 JM5019 JN667 JN803 JJ449 JJ605
HBS259 (22-53010B) M11x1.50x144.5mm (x10)	JD536 JD5833 JD539	JM5283 JM5139					
HBS261 (22-53014B) M12x1.50x131mm (x10)							
HBS261 (22-53014B) M12x1.50x131mm (x10)	JD5191 JD5190	JM5087	KG5157 10x20x2mm PB907 14x21x2mm	HR5046	NA5035 27x47x7mm, FPM (50-319474-00) NA5191 42x62x7mm, PTFE (50-319500-00) NA5192 90x110x7mm, PTFE (50-319501-00)	HL5016 [245]	
HBS261 (22-53014B) M12x1.50x131mm (x10)							
HBS227 (22-17018B) M12x1.25x218mm (x10)							
		JM5283 JM5139					
HBS297 (22-17022B) M9x1.25x91mm (x9) M9x1.25x56mm (x1)	JC973 (31-021833-10)	JN803 (50-027374-00)	JJ449 JJ605	HR599 (24-31919-10/0)	NA5177 42x56x7mm, FPM (50-319189-00) NB808 64x80x8mm, FPM	LR922 [70] KA295 [13] HJ291 [39]	
HBS052 (22-17006B) M9x1.25x95mm (x10)	JD148 (31-025907-10) JD5375 (x2) (31-029968-00) JF145 (MLS)	JN667 (50-026094-00) JN667C1 (Rubber)	HR354 [94]	HR599 (24-31919-10/0)	NA5053 30x42x7mm, FPM (50-319488-00) NA5057 27x37x7mm, FPM NB815 23x35x7mm, FPM (50-319523-00) NB814 70x88x8mm, FPM (50-306350-50)	HL5024 [245] KA5032 [53] LV695 [53] HJ280 [39] JR673 [11] LB177 [46]	
HBS052 (22-17006B) M9x1.25x95mm (x10)	JA5010 JD5375 (x2) (31-029968-00) JF145 (MLS)	JM5019 JN667 (50-026094-00)	HR354 [94]	HR599 (24-31919-10/0)	NA5053 30x42x7mm, FPM (50-319488-00) NB815 23x35x7mm, FPM (50-319523-00) NA5057 27x37x7mm, FPM NA5061 74x88x8mm, FPM	HL5024 [245] KA5032 [53] LV695 [53] JR673 [11] LB177 [46]	



KW/PS



Siena 1.2L					09/98 →	283	AE5240 (MLS) (30-029844-00) AE5550 (Fibre) [249] (30-029928-00) BV670 (Fibre) (30-027185-00)		CE5240 [162] (21-29844-20/0) DV672 [163] (21-27185-22/0)	EV670 (22-27185-00/0)
178 B5.000	1242	4	70.80	Injection		44/60				
Siena 1.2L					09/01 →	284	BV670 (Fibre) (30-027185-00) 178C4.066 188A4.000		DV672 [163] (21-27185-22/0) 188A4.000 DV675 (21-27185-00/0) 178 C4.066	GV671 178 C4.066
188 A4.000	1242	4	70.80	Injection		44/60				
178 C4.066	1242	4	70.80	Injection, SOHC						
Siena 1.4L					04/96 →	285	AY450 (Fibre) [249] BR620 (Fibre) [249] (30-027865-00)		DR620 (21-26295-21/0)	ET400 GR620
178 B2.000/178B2.016	1372	4	80.50	SPi, SOHC		51/69				
Siena 1.6L					11/00 →	286	AB5150 (Fibre) (30-029342-00) AD5970 (MLS) (30-029779-00)		CB5150 CD5970 (21-29779-20/0)	EB5150 (22-29342-00/0) FD5970 (20-29779-00/0)
182 B6.000	1596	4	80.50	i.e.		76/103				
Siena 1.6L 16V					09/98 →	287				ET400
178 B3.000	1581	4	86.40			74-78/ 101				
Siena 1.9L D Diesel					11/00 →	288	BZ790 (MLS), 0.80mm (30-028707-00) BZ800 (MLS), 0.90mm, 1 Notch (30-028708-00) BZ810 (MLS), 1.00mm, 2 Notches (30-028709-00)			
223 A6.000	1910	4	82.00			44/60				
Stilo 1.2L 16V					02/02 →	289	AD5830 (MLS) (30-029765-00) BY380 (Fibre), 1.65mm (30-028024-30)		DY383 (21-28024-23/0) →Eng.0616937 CE5181 (21-29832-21/0) Eng.0616937→	GY383 (20-28024-03/0) →Eng.0616937
188 A5.000	1242	4	70.80	Injection, DOHC		59/80				
Stilo 1.4L 16V					01/04 →	290	AG6220 (MLS) (30-030139-00) →04/06 AG7310 (MLS) (30-030140-00) 04/06→		CG6220 (21-30139-00/0) →04/06 CG7310 (21-30140-00/0) 04/06→	EE5180 (22-29832-00/0)
843 A1.000	1367	4	72.00	DOHC		66-70/ 90-95				
Stilo 1.4L 16V					03/05 →	291	AG6220 (MLS) (30-030139-00) →04/06 AG7310 (MLS) (30-030140-00) 04/06→		CG6220 (21-30139-00/0) →04/06 CG7310 (21-30140-00/0) 04/06→	EE5180 (22-29832-00/0)
192 B2.000	1368	4	72.00	DOHC		66/89				
Stilo 1.6L 16V					10/01 →	292	AB5150 (Fibre) (30-029342-00) →Eng.505168 AD5970 (MLS) (30-029779-00) Eng.505169→		CB5150 →Eng.505168 CD5970 (21-29779-20/0)	EB5150 (22-29342-00/0) FD5970 (20-29779-00/0)
182 B6.000	1596	4	80.50	i.e.		76/103				











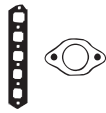

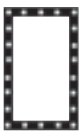

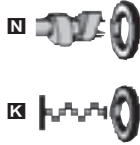

















































								
HBS052  (22-17006B) M9x1.25x95mm (x10)	JA5010  JD5375  (x2) (31-029968-00)	JM5019	HR354 [94]	HR599  (24-31919-10/0)	 NA5053 30x42x7mm, FPM (50-319488-00)  NB815  23x35x7mm, FPM (50-319523-00)  NA5061  74x88x8mm, FPM	HL5024 [245]  LV695 [53] JR673 [11] LB177 [46]		 AB5150  AD5970  AE5240  AY450, BR620  BV670  BY380  BZ790, BZ800, BZ810
HBS052  (22-17006B) M9x1.25x95mm (x10)	JA5010  188A4.000 JD150  178 C4.066 JD159  31-0249111-00 178 C4.066 JD5375  (31-029968-00)	JM5019 188A4.000 JM5181 (50-029843-00) (Rubber) 188A4.000 JN667 (50-026094-00) 178 C4.066	HR354 [94] 188A4.000		 NA5053 30x42x7mm, FPM (50-319488-00)  NB815  23x35x7mm, FPM (50-319523-00)  NA5061  74x88x8mm, FPM		 JM5176  JN667  JN805  JN973  JP049  JJ453	
HBS051  (22-17001B) M10x1.25x98mm (x5) M10x1.25x84mm (x5)	JD146 (31-027221-10)	JM654 JN805 [156] (31-026819-00) JPO49 (31-026820-00)	JJ453	HR363 	 NA5187 (x2) 30x52x7mm, ACM (50-319492-00)  NB818  40x56x7mm, ACM		 JA5005  JA5006  JA5010  JD146	
HBS131  (22-17014B) M10x1.25x100mm (x10)	JD340  (31-028789-00) JD5341  (50-029940-00)	JN973 (31-028483-00)			 NA5187 (x2) 30x52x7mm, ACM (50-319492-00)  NB818  40x56x7mm, ACM  NF887  [3] 64x112.5x20mm, FPM (50-319393-00)		 JA5005  JA5006  JA5010  JD146	
HBS131  (22-17014B) M10x1.25x100mm (x10)					 NB818  40x56x7mm, ACM		 JA5010  JD146	
HBS247  (22-17019B) M9x1.25x87mm (x10)	JA5005  (50-029899-00) (Rubber) JA5006  (31-029900-00)	JM5176 (50-029831-00)		HR814  (50-319374-00)	 NA5058 40x55x7mm, FPM  NA5057  27x37x7mm, FPM  LK5001  [3] 74x187.5x17mm, FPM (50-319456-00)	KA5032 [53] LV695 [53] KK5001 [45] KK5002 [45] KK5155 [45] KL479 [45]	 JD150  JD159  JD340  JD5143	
HBS247  (22-17019B) M9x1.25x87mm (x10)		JM5176 (50-029831-00)			 NA5058 40x55x7mm, FPM  NA5057  27x37x7mm, FPM  LK5001  [3] 74x187.5x17mm, FPM (50-319456-00)		 JD5143  JD5341  JD5375	
HBS247  (22-17019B) M9x1.25x87mm (x10)					 NA5058 40x55x7mm, FPM  NA5057  27x37x7mm, FPM  LK5001  [3] 74x187.5x17mm, FPM (50-319456-00)		 JD5341  JD5375  JD566	
HBS131  (22-17014B) M10x1.25x100mm (x10)	JD340  (31-028789-00) JD566  JD5143  (31-028790-10)	JN973 (31-028483-00)		HR800 	 NA5187 (x2) 30x52x7mm, ACM (50-319492-00)  NB818  40x56x7mm, ACM  NF887  [3] 64x112.5x20mm, FPM (50-319393-00)		 JM5019	



KW/PS



Stilo 1.8L 16V		10/01 →		293		AA5420 (MLS), 0.38mm (30-029064-00)		CA5421 (21-29064-21/0)		EA5420 (22-29064-00/0)	
192 A4.000	1747	4	82.00	DOHC	96/98/ 130- 133						
Stilo 1.9L D Multijet Diesel		09/05 →		294		AG7390 (MLS), 0.82mm (30-030144-00)		CA5560▲ (21-29093-21/0)			
192A9.000	1910	4	82.00	Direct Injection, SOHC	74/100			CA5561▲ (21-29093-20/0)			
192 A8.000	1910	4	82.00	Direct Injection, SOHC				Eng.4081111 →			
Stilo 1.9L D Multijet Diesel		09/05 →		295		AD5840 (MLS), 0.82mm, 0 Holes (30-029766-00)		CD5840▲ (21-29766-20/0)		EE5181 (22-29832-01/0)	
937A5.000	1910	4	82.00	Direct Injection, DOHC	110/150						
						AD5850 (MLS), 0.92mm, 1 Hole (30-029767-00)					
						AD5860 (MLS), 1.02mm, 2 Holes (30-029768-00)					
Stilo 1.9L JTD Diesel		02/02 →		296		AG7390 (MLS), 0.82mm (30-030144-00)		CA5560▲ (21-29093-21/0)		FA5560▲ (20-29095-00/0)	
192 A3.000	1910	4	82.00	Direct Injection, SOHC	73/99			CA5561▲ (21-29093-20/0)			
192	1910	4	82.00	Direct Injection, SOHC	85/115			Eng.4081111 →			
A1.000/937A7.000						AA5570 (MLS), 0.92mm, 1 Hole (30-029094-10)					
						AA5580 (MLS), 1.02mm, 2 Holes (30-029095-10)					
Stilo 1.9L JTD Diesel		10/01 →		297		AG7440 (MLS) (30-030149-00)		CA5560▲ (21-29093-21/0)		EG7390 (22-30144-00/0)	
192	1910	4	82.00	Direct Injection, SOHC	85/115			192A1.000		937A7.000	
A1.000/937A7.000						937A7.000		CG7390▲ (21-30144-00/0)		FA5560▲ (20-29095-00/0)	
						AG7390 (MLS), 0.82mm (30-030144-00)		937A7.000		192A1.000	
						937A7.000		CA5561▲ (21-29093-20/0)			
						AA5570 (MLS), 0.92mm, 1 Hole (30-029094-10)		Eng.4081111 →			
						192A1.000		192A1.000			
						AG7400 (MLS), 0.92mm, 1 Hole (30-030145-00)					
						937A7.000					
						AA5580 (MLS), 1.02mm, 2 Holes (30-029095-10)					
Stilo 1.9L JTD Diesel		01/04 →		298		AD5840 (MLS), 0.82mm, 0 Holes (30-029766-00)		CD5840▲ (21-29766-20/0)		EE5181 (22-29832-01/0)	
192 A5.000	1910	4	82.00	Direct Injection, DOHC	103/140						
						AD5850 (MLS), 0.92mm, 1 Hole (30-029767-00)					
						AD5860 (MLS), 1.02mm, 2 Holes (30-029768-00)					
Stilo 1.9L JTD Diesel		09/03 →		299							
Stilo 1.9L JTD Multi Wagon Diesel		09/03 →									
937A4.000	1910	4	82.00	Direct Injection, DOHC	93/126						
Stilo 1.9L JTD Diesel		04/04 →		300							
Stilo 1.9L JTD Multi Wagon Diesel		04/04 →									
192 B1.000	1910	4	82.00	Direct Injection, DOHC	100/136						
Stilo 1.9L JTD Diesel		09/04 →		301							
192 B5.000	1910	4	82.00	Direct Injection, SOHC	66/90						

      							
HBS132  (22-17015B) M10x1.25x254mm (x10)	JD271  (31-027450-10) (Metal) JD273  (31-027729-00) (MLS)	HL701  (24-28782-00/0)			NA5053  30x42x7mm, FPM (50-319488-00) NA5069  55x68x8mm, FPM (50-319515-00) NA5070  31x41x7mm, FPM (50-319524-00) NF888  [3] 93x139.7x12mm, FPM (50-319526-00)	HL5030 [245] 	 AA5420  AA5570, AA5580  JA5035  JD271  JD273  JD468  JD5376  JD580  HL701  JM5028  JM5204
HBS227  (22-17018B) M12x1.25x218mm (x10)					NA5053  30x42x7mm, FPM (50-319488-00)		
HBS370  (22-17026B) M12x1.25x225mm (x10) 04/03 →	JD5376  (31-029969-00)	JM7055 (Steel Elastomer)		HR5095 	NA5053  30x42x7mm, FPM (50-319488-00) NA5070  31x41x7mm, FPM (50-319524-00) NF888  [3] 93x139.7x12mm, FPM (50-319526-00)	HL5031 [245] 	
HBS227  (22-17018B) M12x1.25x218mm (x10)	JA5035  (31-029407-00) JD580  JD468  (31-028377-00) (MLS)	JM5028 (31-029635-00) →Eng.4081110 JM5204 (50-029935-00) Eng.4081111 →		HR363 	NA5053  30x42x7mm, FPM (50-319488-00) NA5070  31x41x7mm, FPM (50-319524-00) NF888  [3] 93x139.7x12mm, FPM (50-319526-00)	HL5031 [245] 	
HBS227  (22-17018B) M12x1.25x218mm (x10)	JA5035  (31-029407-00) JD580  JD468  (31-028377-00) (MLS)	JM5028 (31-029635-00) →Eng.4081110 JM5204 (50-029935-00) Eng.4081111 →		HR363 	NA5053  30x42x7mm, FPM (50-319488-00) NA5070  31x41x7mm, FPM (50-319524-00) NF888  [3] 93x139.7x12mm, FPM (50-319526-00)	HL5031 [245] 	
HBS370  (22-17026B) M12x1.25x225mm (x10)	JD5376  (31-029969-00)	JM7055 (Steel Elastomer)		HR363  HR5095 	NA5053  30x42x7mm, FPM (50-319488-00) NA5070  31x41x7mm, FPM (50-319524-00) NF888  [3] 93x139.7x12mm, FPM (50-319526-00)	HL5031 [245] 	
HBS370  (22-17026B) M12x1.25x225mm (x10)		JM7055 (Steel Elastomer)		HR5095 			
		JM7055 (Steel Elastomer)		HR5095 			
HBS227  (22-17018B) M12x1.25x218mm (x10)							







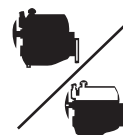



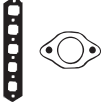

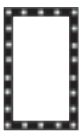



























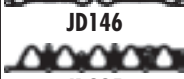















































































FIAT



KW/PS



Stilo 2.4L 20V				10/01 →	302	AA5590 (MLS), 0.49mm (30-029275-00)	CA5590 [169]	ED5960 (22-29778-00/0)
192 A2.000	2446	5	83.00	DOHC	125/170			
Strada 1.1L 60 Comfort				01/83 →	303	BJ850 (Fibre) (30-024779-10)	DJ851▲ DJ852 (21-24779-21/0)	GJ852
138 B.000	1116	4	80.00		41/55			
Strada 1.2L				06/99 →	304	AE5240 (MLS) (30-029844-00) AE5550 (Fibre) [249] (30-029928-00) BV670 (Fibre) (30-027185-00)	CE5240 [162] (21-29844-20/0) DV672 [163] (21-27185-22/0)	EE5242 EV670 (22-27185-00/0)
178 B5.000	1242	4	70.80	Injection	44/60			
Strada 1.2L				04/03 →	305	AE5240 (MLS) (30-029844-00) AE5550 (Fibre) [249] (30-029928-00) BV670 (Fibre) (30-027185-00)	DV672 [163] (21-27185-22/0) DV675 (21-27185-00/0) CE5242 Eng.2939661 →	EE5242 EV670 (22-27185-00/0)
188 A4.000	1242	4	70.80	Injection	44/60			
Strada 1.3L D Multijet Diesel				05/06 →	306		CD5820▲	ED5820 FD5820▲
223 A9.000	1248	4	69.60	Direct Injection, DOHC				
Strada 1.7L TD Diesel				04/96 →	307	BR680 (Graphite), 1.65mm BT220 (Fibre), 1.65mm (30-025166-10) BV680 (Fibre), 1.67mm, 0 Notches (30-026296-10) BV690 (Fibre), 1.75mm, 1 Notch BV700 (Fibre), 1.85mm, 2 Notches (30-027859-00) BW980 (Fibre), 1.93mm, 3 Notches	DV680▲ (21-25142-26/0)	EV684 (22-25142-00/0) GV680▲ [100]
146 D7.000/176 A5.000 176 B7.000 176 A3.000	1697	4	82.60	Turbo SOHC, Turbo	46/63 46/63 51-53/ 69			
Strada 1.9L D Diesel				12/00 →	308	BZ790 (MLS), 0.80mm (30-028707-00) BZ800 (MLS), 0.90mm, 1 Notch (30-028708-00) BZ810 (MLS), 1.00mm, 2 Notches (30-028709-00)	DZ790▲ (21-28707-20/0)	GZ790▲
223 A6.000	1910	4	82.00		44/60			
Strada 1.9L JTD Diesel				04/03 →	309	AG7390 (MLS), 0.82mm (30-030144-00) AA5570 (MLS), 0.92mm, 1 Hole (30-029094-10) AA5580 (MLS), 1.02mm, 2 Holes (30-029095-10)	CA5560▲ (21-29093-21/0) CA5561▲ (21-29093-20/0) Eng.4081111 →	FA5560▲ (20-29095-00/0)
188 A2.000	1910	4	82.00	Direct Injection	73/99			

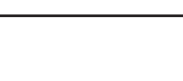









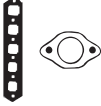

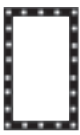

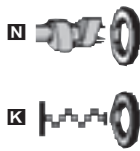











								
HBS133  (22-17016B) M10x1.25x254mm (x12)	JD225  (31-027448-00) JD226  (31-028581-00)	JM5018 (Rubber)	HR354 [94]	HR800 	 NA5053 30x42x7mm, FPM (50-319488-00)  NA5069 55x68x8mm, FPM (50-319515-00)  NA5070 31x41x7mm, FPM (50-319524-00)  NF888 [3] 93x139.7x12mm, FPM (50-319526-00)	HL5030 [245]  KL477 [70] KA845 [13] HJ283 [39]  KK5156 [45]		 AA5570, AA5580  AA5590  AE5240  BJ850  BR680  BT220  BV670  BV680, BV690, BV700, BW980  BZ790, BZ800, BZ810  JA5008  JA5010  JA5011  JA5035  JC738  JD146  JD225  JD226  JD468
HBS051  (22-17001B) M10x1.25x98mm (x5) M10x1.25x84mm (x5)	JD146 (31-027221-10)	JM654 JN805 [156] (31-026819-00) JP049 (31-026820-00)	JJ453	HR596 	 NA5187 30x52x7mm, ACM (50-319492-00)  NB818 40x56x7mm, ACM  NA5049 64x80x8mm, ACM	KA293 [13] KA294 [13] KT465 [54] KD717 [91]		 JD5375  JD580  JM5003  JM5018  JM5019  JM5028  JM5204  JN459  JN805  JP049  JJ298  JJ398  JJ453
HBS052  (22-17006B) M9x1.25x95mm (x10)	JA5010  JD5375  (x2) (31-029968-00)	JM5019	HR354 [94]	HR599  (24-31919-10/0)	 NA5053 30x42x7mm, FPM (50-319488-00)  NB815 23x35x7mm, FPM (50-319523-00)  NA5061 74x88x8mm, FPM	HL5024 [245]  LV695 [53] JR673 [11] LB177 [46]		 JM5028  JM5204  JN459  JN805  JP049 
HBS052  (22-17006B) M9x1.25x95mm (x10)	JA5010  JD5375  (x2) (31-029968-00)	JM5019 JM5181 (50-029843-00) (Rubber)			 NA5053 30x42x7mm, FPM (50-319488-00)  NB815 23x35x7mm, FPM (50-319523-00)  NA5061 74x88x8mm, FPM	HL5024 [245] 		 JN459  JN805  JP049 
HBS353  (22-17025B) M10x1.25x119mm (x10)								 JA5008  JA5010  JA5011 
HBS095  (22-17007B) M12x1.25x133mm (x10)	JC738 (31-026290-10)	JN459 (31-025142-10)	JJ298 JJ398 (31-027379-00)	HR596 	 NA5187 30x52x7mm, ACM (50-319492-00)  NB742 30x43x8mm, ACM (50-319408-00)  NB732 74x90x10mm, FPM  NA5062 74x90x10mm, ACM	LV583 [53] LV589 [11] LT498 [45] LV582 [45]		 JA5010  JA5011  JA5035  JC738  JD146  JD225  JD226  JD468
HBS227  (22-17018B) M12x1.25x218mm (x10)	JA5008  (31-029958-00) (Rubber) JA5011  (31-029959-00) (Rubber) JD468  (31-028377-00) (MLS)	JM5003 (50-029960-00)		HR363 	 NA5053 30x42x7mm, FPM (50-319488-00)  NA5070 31x41x7mm, FPM (50-319524-00)  NF888 [3] 93x139.7x12mm, FPM (50-319526-00)	HL5031 [245] 		 JA5035  JC738  JD146  JD225  JD226  JD468
HBS227  (22-17018B) M12x1.25x218mm (x10)	JA5035  (31-029407-00) JD580  JD468  (31-028377-00) (MLS)	JM5028 (31-029635-00) →Eng.4081110 JM5204 (50-029935-00) Eng.4081111 →		HR363 	 NA5053 30x42x7mm, FPM (50-319488-00)  NA5070 31x41x7mm, FPM (50-319524-00)  NF888 [3] 93x139.7x12mm, FPM (50-319526-00)	HL5031 [245]  KL476 [70] JR5001 [11]		 JD226  JD468



KW/PS



Talento 1.9L D Diesel		03/89 → 03/94		310		BR680 (Graphite), 1.65mm		DV680▲		GV680▲ [100]		
Talento Van 1.9L D Diesel		03/89 → 03/94				BV680 (Fibre), 1.67mm, 0 Notches (30-026296-10)		(21-25142-26/0)				
149 B1.000		1929	4	82.60	SOHC	52/71	BV690 (Fibre), 1.75mm, 1 Notch					
							BV700 (Fibre), 1.85mm, 2 Notches (30-027859-00)					
							BW980 (Fibre), 1.93mm, 3 Notches					
Tempra 1.4L i.e.		03/92 → 08/96		311		AY450 (Fibre) [249]						
160 A1.046/836 A4.000		1372	4	80.50	SOHC	51/69	BR620 (Fibre) [249] (30-027865-00)					
Tempra 1.4L i.e.		03/91 → 08/96		312		AY450 (Fibre) [249]		DR620		GR620		
159 A2.000		1372	4	80.50	Injection	53/72	BR620 (Fibre) [249] (30-027865-00)		(21-26295-21/0)			
Tempra 1.4Li Station		01/90 →		313		AY450 (Fibre) [249]		DR620		GR620		
146 C1.000/146 D5.000		1372	4	80.50	SOHC	51-53/ 69-72	BR620 (Fibre) [249] (30-027865-00)		(21-26295-21/0)			
Tempra 1.6L		03/90 → 04/93		314		BT410 (Fibre)		DP689		GT446 [12]		
159 A3.000		1581	4	86.40	Carburettor, SOHC	63/86	BT420 (Fibre) (30-025413-10)		→12/90		(20-26647-03/0)	
									DT446		01/91 →	
									(21-26647-23/0)			
									01/91 →			
Tempra 1.6L i.e.		06/90 → 07/92		315		AY460 (Fibre) [249]		DR630		ET400		
159 A3.046		1585	4	86.40	SOHC	57-62/ 78-84	BR630 (Fibre) (30-027866-00)		(21-26294-21/0)		GR630 (20-26294-01/0)	
Tempra 1.6L i.e.		10/92 → 08/96		316		AY460 (Fibre) [249]		DR630		ET400		
835 C1.000		1581	4	86.40	SOHC	55-57/ 75-78	BR630 (Fibre) (30-027866-00)		(21-26294-21/0)		GR630 (20-26294-01/0)	
159 A3.048		1585	4	86.40	SOHC	61/82					GR631 [12] (20-27866-00/0)	
Tempra 1.6L i.e.		10/90 → 08/96		317		AY460 (Fibre) [249]		DR630		ET400		
835 C1.000		1581	4	86.40	SOHC	55-57/ 75-78	BR630 (Fibre) (30-027866-00)		(21-26294-21/0)		GR632 (20-27866-01/0)	
159 A3.046		1585	4	86.40	SOHC	57-62/ 78-84			→12/93			











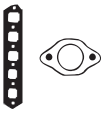

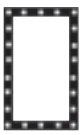

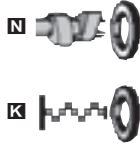



								
HBS095  (22-17007B) M12x1.25x133mm (x10)	JC738 (31-026290-10)	JN459 (31-025142-10)	JJ298 (Cork) JJ398 (31-027379-00)	HR596 	NA5187 30x52x7mm, ACM (50-319492-00) NB742 30x43x8mm, ACM (50-319408-00) NB732 74x90x10mm, FPM NA5062 74x90x10mm, ACM	LB175 [70] LV586 [70] KA556 [13] LT021 [13] [164] LT023 [13] LV583 [53] HJ283 [39]  KT465 [54] LT019 [86] LV588 [86] JR749 [11] KT639 [11] LV589 [11] LT498 [45] LV582 [45] LV585 [45]	AY450, BR620, AY460, BR630 BR680 BT410 BT420 BV680, BV690, BV700, BW980 JA757	
HBS051  (22-17001B) M10x1.25x98mm (x5) M10x1.25x84mm (x5)	JD146 (31-027221-10)	JP049 (31-026820-00)	JJ453	HR363 		KT754 [11] KV122 [56]	JC738 JD146	
HBS051  (22-17001B) M10x1.25x98mm (x5) M10x1.25x84mm (x5)	JD146 (31-027221-10) JF150 (31-027151-00)	JM654 JN805 [156] (31-026819-00) JP049 (31-026820-00)	JJ453	HR363 	NA5187 (x2) 30x52x7mm, ACM (50-319492-00) NB818 40x56x7mm, ACM NA5049 64x80x8mm, ACM NB808 64x80x8mm, FPM	KA294 [13]	JF150	
HBS051  (22-17001B) M10x1.25x98mm (x5) M10x1.25x84mm (x5)	JD146 (31-027221-10) JF150 (31-027151-00)	JM654 JN805 [156] (31-026819-00) JP049 (31-026820-00)	JJ453	HR363 	NA5187 (x2) 30x52x7mm, ACM (50-319492-00) NB818 40x56x7mm, ACM		JN459 JN643	
HBS051  (22-17001B) M10x1.25x98mm (x5) M10x1.25x84mm (x5)	JA757  (31-022346-10)	JN643 (31-027225-00) JN645  [156] (31-027441-00)	JJ298 JJ413 (31-027315-00)	HR599  (24-31919-10/0)	NA5187 (x2) 30x52x7mm, ACM (50-319492-00) NA5051 40x56x7mm, FPM NB742 30x43x8mm, ACM (50-319408-00) NA5049 64x80x8mm, ACM NB808 64x80x8mm, FPM NA5050 70x90x10mm, ACM	KA294 [13] LB025 [13] JS081 [11] KT639 [11] LV585 [45]	JN645 JN805	
HBS051  (22-17001B) M10x1.25x98mm (x5) M10x1.25x84mm (x5)	JD146 (31-027221-10)	JP049 (31-026820-00)	JJ453	HR363 	NA5187 (x2) 30x52x7mm, ACM (50-319492-00) NB818 40x56x7mm, ACM NA5049 64x80x8mm, ACM NB808 64x80x8mm, FPM		JP049 JJ298	
HBS051  (22-17001B) M10x1.25x98mm (x5) M10x1.25x84mm (x5)	JD146 (31-027221-10)	JM654 01/89 → 12/93 JN805 [156] (31-026819-00) 01/89 → 12/93 JP049 (31-026820-00) 01/93 →	JJ453	HR363 	NA5187 (x2) 30x52x7mm, ACM (50-319492-00) NB818 40x56x7mm, ACM NA5049 64x80x8mm, ACM NB808 64x80x8mm, FPM	KA294 [13]	JJ398	
HBS051  (22-17001B) M10x1.25x98mm (x5) M10x1.25x84mm (x5) → 12/93 HBS092  (22-17003B) M10x1.25x115mm (x10)	JD146 (31-027221-10)	JN805 [156] (31-026819-00) → 12/93 JM654 01/89 → 12/93 JP049 (31-026820-00) 01/94 →	JJ453	HR363 	NA5187 (x2) 30x52x7mm, ACM (50-319492-00) NA5051 40x56x7mm, FPM NB818 40x56x7mm, ACM NA5049 64x80x8mm, ACM NB808 64x80x8mm, FPM	KA294 [13]	JJ413 JJ453	



KW/PS



Tempra 1.6L i.e.		06/94 → 08/96		318	AY460 (Fibre) [249] BR630 (Fibre) (30-027866-00)	DR631 (21-27866-20/0)	ET400 GR631 [12] (20-27866-00/0)
159 B9.000	1581	4	86.40	Injection, SOHC	63-66/ 86-90		
Tempra 1.8L i.e.		03/92 → 08/96		319	BT440 (Fibre) (30-026647-30)	DT440	GT440 (20-26647-02/0)
Tempra 1.8Li SLX		01/93 →					
159 A4.000/ 159 A4.046/159 A4.046	1756	4	84.00	i.e., DOHC	76/103		
Tempra 1.8L i.e.		09/93 → 08/96		320	BT440 (Fibre) (30-026647-30)	DT449 (21-26647-30/0)	GT449 (20-26647-11/0)
836 A5.000	1756	4	84.00	DOHC	71-74/ 97-101		
835 C2.000	1756	4	84.00	i.e., DOHC	76/103		
Tempra 1.9L D Diesel		07/91 → 08/96		321	BT220 (Fibre), 1.65mm (30-025166-10) BT230 (Fibre), 1.80mm, 1 Notch BT240 (Fibre), 1.95mm, 2 Notches (30-025168-10)	DV680▲ (21-25142-26/0)	EV684 (22-25142-00/0) GV680▲ [100]
160 A7.000	1929	4	82.60		48/65		
Tempra 1.9L TD Diesel		05/90 → 08/96		322	BR680 (Graphite), 1.65mm BV680 (Fibre), 1.67mm, 0 Notches (30-026296-10) BV690 (Fibre), 1.75mm, 1 Notch BV700 (Fibre), 1.85mm, 2 Notches (30-027859-00) BW980 (Fibre), 1.93mm, 3 Notches	DV680▲ (21-25142-26/0)	EV684 (22-25142-00/0) GV680▲ [100]
160 A6.000/160 B6.046	1929	4	82.60	SOHC	66/89		
160 D1.000	1929	4	82.60	SOHC	68/92		
Tempra 1.9L TD Diesel		07/91 → 02/95		323	BR680 (Graphite), 1.65mm BT220 (Fibre), 1.65mm (30-025166-10) BV680 (Fibre), 1.67mm, 0 Notches (30-026296-10) BV690 (Fibre), 1.75mm, 1 Notch BV700 (Fibre), 1.85mm, 2 Notches (30-027859-00) BW980 (Fibre), 1.93mm, 3 Notches	DV680▲ (21-25142-26/0)	EV684 (22-25142-00/0) GV680▲ [100]
160 A6.000/160 B6.046	1929	4	82.60	SOHC	66/89		
160 D1.000	1929	4	82.60	SOHC	68/92		
Tempra 2.0L i.e.		10/90 → 08/96		324	BT440 (Fibre) (30-026647-30)	DT449 (21-26647-30/0)	GT449 (20-26647-11/0)
Tempra 2.0L i.e. 4X4		03/92 → 03/95					
159 A6.046	1995	4	84.00	i.e., DOHC	83-85/ 113- 116		
Tempra 2.0L SW 4x4		10/87 → 08/96		325	BT440 (Fibre) (30-026647-30)	DT440	GT440 (20-26647-02/0)
154 C3.046	1995	4	84.00	i.e., DOHC	88/120		







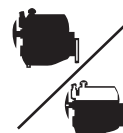



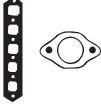

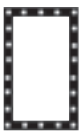

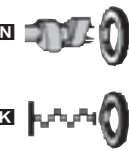



















































































								 AY460, BR630	 JJ453
HBS092 ® (22-17003B) M10x1.25x115mm (x10)	JD146 (31-027221-10)	JP024 50-027505-00	JJ453	HR363 ■	NA5187 (x2) 30x52x7mm, ACM (50-319492-00) NB818 ■ 40x56x7mm, ACM NA5049 ■ 64x80x8mm, ACM NA5051 ■ 40x56x7mm, FPM	KA294 [13]		 BR680	
HBS092 ® (22-17003B) M10x1.25x115mm (x10)	JC662 ■ (31-026050-10) JA757 ■ (31-022346-10)	JN643 (x2) (31-027225-00) JN819 (x2) JN948 (x2) (31-027428-00)	JJ298 JJ366 (31-027488-00) JJ413 (31-027315-00)	HR363 ■	NA5187 (x2) 30x52x7mm, ACM (50-319492-00) NB742 ■ 30x43x8mm, ACM (50-319408-00) NB825 ■ 30x43x8mm, FPM (50-306773-50) NB732 ■ 74x90x10mm, FPM NA5062 ■ 74x90x10mm, ACM	KT465 [54] KT639 [11]		 BT220, BT230, BT240	
HBS092 ® (22-17003B) M10x1.25x115mm (x10)	JC662 ■ (31-026050-10) JD019 ■ (31-027032-10)	JN819 (x2) JN948 (x2) (31-027428-00)	JJ366 (31-027488-00) JJ413 (31-027315-00)	HR363 ■	NA5187 (x2) 30x52x7mm, ACM (50-319492-00) NB742 ■ 30x43x8mm, ACM (50-319408-00) NB825 ■ 30x43x8mm, FPM (50-306773-50) NB732 ■ 74x90x10mm, FPM NA5062 ■ 74x90x10mm, ACM	LB175 [70] LB025 [13] OK627 [14] KT465 [54] JR749 [11] JS081 [11] KT639 [11] LA055 [56]		 JA757	
HBS095 ® (22-17007B) M12x1.25x133mm (x10)	JC738 (31-026290-10)	JN459 (31-025142-10)	JJ298 (Cork) JJ398 (31-027379-00)	HR596 ■	NA5187 30x52x7mm, ACM (50-319492-00) NB742 ■ 30x43x8mm, ACM (50-319408-00) NB732 ■ 74x90x10mm, FPM NA5062 ■ 74x90x10mm, ACM	HL5028 [245]■ LV586 [70] LT498 [45]		 JD019	
HBS095 ® (22-17007B) M12x1.25x133mm (x10)	JC738 (31-026290-10)	JN459 (31-025142-10)	JJ298 (Cork) JJ398 (31-027379-00)	HR363 ■ HR596 ■	NA5187 30x52x7mm, ACM (50-319492-00) NB742 ■ 30x43x8mm, ACM (50-319408-00) NB732 ■ 74x90x10mm, FPM NA5062 ■ 74x90x10mm, ACM	HL5028 [245]■ LB175 [70] LV586 [70] LT021 [13] [164] LV583 [53] HJ283 [39]■		 JN459	
HBS095 ® (22-17007B) M12x1.25x133mm (x10)	JC738 (31-026290-10)	JN459 (31-025142-10)	JJ298 (Cork) (Rubber) JJ398 (31-027379-00)	HR363 ■ HR596 ■	NA5187 30x52x7mm, ACM (50-319492-00) NB742 ■ 30x43x8mm, ACM (50-319408-00) NB732 ■ 74x90x10mm, FPM NA5062 ■ 74x90x10mm, ACM	HL5028 [245]■ LV586 [70] LT498 [45]		 JN643, JN819	
HBS093 ® (22-17005B) M10x1.25x172mm (x10)	JC662 ■ (31-026050-10) JD019 ■ (31-027032-10)	JN643 (x2) (31-027225-00) JN819 (x2) JN948 (x2) (31-027428-00)	JJ298 (Cork) JJ366 (31-027488-00) JJ413 (31-027315-00)	HR363 ■	NA5187 (x2) 30x52x7mm, ACM (50-319492-00) NB742 ■ 30x43x8mm, ACM (50-319408-00) NB825 ■ 30x43x8mm, FPM (50-306773-50) NB732 ■ 74x90x10mm, FPM	HL5028 [245]■ LB175 [70] LB025 [13] [159] OK627 [14] HJ283 [39]■ OK473 [160]		 JP024	
HBS092 ® (22-17003B) M10x1.25x115mm (x10)	JC662 ■ (31-026050-10) JA757 ■ (31-022346-10)	JN643 (x2) (31-027225-00) JN819 (x2) JN928 (x2) [102] (50-027319-00) JN948 (x2) (31-027428-00)	JJ298 (Cork) JJ366 (31-027488-00) JJ413 (31-027315-00)	HR363 ■	NA5187 (x2) 30x52x7mm, ACM (50-319492-00) NB742 ■ 30x43x8mm, ACM (50-319408-00) NB732 ■ 74x90x10mm, FPM NA5062 ■ 74x90x10mm, ACM	KT465 [54]		 JJ298	
								 JJ366	
								 JJ398	
								 JJ413	

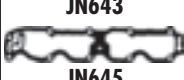

KW/PS



Tipo 1.1L				01/88 → 10/91		326	BP280 (Fibre), 1.65mm (30-026046-30) BV940 (Fibre), 2.00mm (30-028799-00)		CV940 [170] (21-28799-21/0) DV675 (21-27185-00/0)	GP282 [171] (20-26046-00/0)
160 A3.000	1108	4	70.00			41/55				
Tipo 1.4L				07/87 → 12/89		327	AY450 (Fibre) [249] BR620 (Fibre) [249] (30-027865-00)		DR620 (21-26295-21/0)	GR620
160 A1.048	1372	4	80.50			52/71				
160 A1.000	1372	4	80.50	Injection		53/72				
Tipo 1.4L i				01/90 →		328	AY450 (Fibre) [249] BR620 (Fibre) [249] (30-027865-00)		DR620 (21-26295-21/0)	GR620
Tipo 1.4L i.e.				05/89 → 04/95						
160 A1.046/836	1372	4	80.50	SOHC		51/69				
A4.000										
146 C1.000/146	1372	4	80.50	SOHC		51-53/ 69-72				
D5.000										
159 A2.000	1372	4	80.50	Injection		53/72				
Tipo 1.6L				01/88 → 10/91		329	BT410 (Fibre) BT420 (Fibre) (30-025413-10)		DP689 → 12/90 DT446 (21-26647-23/0) 01/91 →	ET400 GT446 [12] (20-26647-03/0) 01/91 →
160 A2.000	1585	4	86.40			61/82				
Tipo 1.6L i SX				10/93 →		330	AY460 (Fibre) [249] BR630 (Fibre) (30-027866-00)		DR630 (21-26294-21/0)	GR630 (20-26294-01/0)
220 A 2.000	1581	4	86.40	Efi, SOHC		55/75				
Tipo 1.6L i.e.				10/92 → 04/95		331	AY460 (Fibre) [249] BR630 (Fibre) (30-027866-00)		DR630 (21-26294-21/0)	GR632 (20-27866-01/0)
835 C1.000	1581	4	86.40	SOHC		55-57/ 75-78				
159 A3.048	1585	4	86.40	SOHC		61/82				
Tipo 1.6L i.e.				07/90 → 01/93		332	AY460 (Fibre) [249]		DR630 (21-26294-21/0)	ET400 GR630 (20-26294-01/0)
159 A3.046	1585	4	86.40	SOHC		57-62/ 78-84				
Tipo 1.6L i.e.				02/88 → 05/91		333	BT420 (Fibre) (30-025413-10)		DT423■	
149 C2.046	1585	4	84.00	Injection, SOHC		61-77/ 83-105				











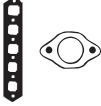

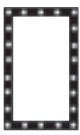

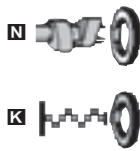

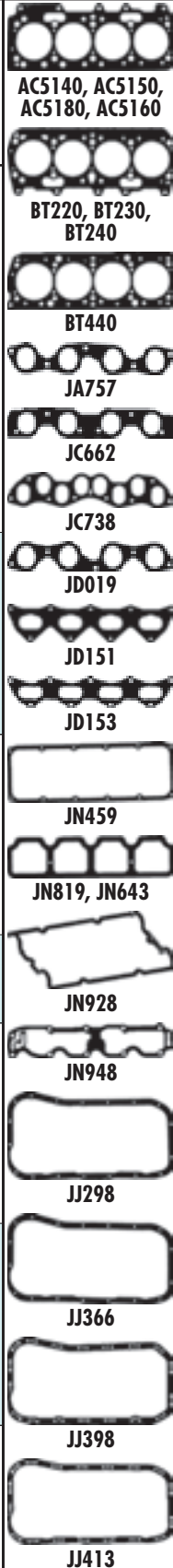
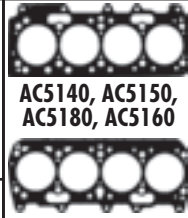













								
HBS052  [22-17006B] M9x1.25x95mm (x10)	JD148  [31-025907-10] JD5375  [31-029968-00]  JF145 (MLS)	JN667 [50-026094-00]	HR354 [94]	HR599  [24-31919-10/0]	 NA5053 30x42x7mm, FPM [50-319488-00]  NB815  23x35x7mm, FPM [50-319523-00]  NB814  70x88x8mm, FPM [50-306350-50]	KA5032 [53] LV695 [53] HJ280 [39]  JR673 [11] LB177 [46]	 AY450, BR620, AY460, BR630	 JJ413
HBS051  [22-17001B] M10x1.25x98mm (x5) M10x1.25x84mm (x5)	JD146 [31-027221-10]  JF150 [31-027151-00]	JM654 JN805 [156] [31-026819-00] JP049 [31-026820-00]	JJ453	HR363 	 NA5187 (x2) 30x52x7mm, ACM [50-319492-00]  NA5051  40x56x7mm, FPM  NB818  40x56x7mm, ACM  NA5049  64x80x8mm, ACM	HJ282 [39] 	 BP280, BV940	 JJ453
HBS051  [22-17001B] M10x1.25x98mm (x5) M10x1.25x84mm (x5)	JD146 [31-027221-10]  JF150 [31-027151-00]	JM654 JN805 [156] [31-026819-00] JP049 [31-026820-00]	JJ453	HR363 	 NA5187 (x2) 30x52x7mm, ACM [50-319492-00]  NB818  40x56x7mm, ACM	KA293 [13] KA294 [13] KA354 [13] LA378 [53] KT465 [54]	 BT410	
HBS051  [22-17001B] M10x1.25x98mm (x5) M10x1.25x84mm (x5)	JC692  [31-027314-00] JA757  [31-022346-10]	JN643 [31-027225-00] JN645  [156] [31-027441-00]	JJ298 (Cork) JJ413 [31-027315-00]	HR599  [24-31919-10/0]	 NA5187 (x2) 30x52x7mm, ACM [50-319492-00]  NB742  30x43x8mm, ACM [50-319408-00]  NA5049  64x80x8mm, ACM  NB808  64x80x8mm, FPM  NA5050  70x90x10mm, ACM  NA5051  40x56x7mm, FPM  NB818  40x56x7mm, ACM	KA294 [13] LB025 [13] JS081 [11] KT639 [11] LV585 [45]	 JC692	
HBS051  [22-17001B] M10x1.25x98mm (x5) M10x1.25x84mm (x5)	JD146 [31-027221-10]  JF150 [31-027151-00]	JP049 [31-026820-00]	JJ453	HR363 	 NA5187 (x2) 30x52x7mm, ACM [50-319492-00]  NB818  40x56x7mm, ACM  NA5049  64x80x8mm, ACM  NA5051  40x56x7mm, FPM	KA354 [13] KT465 [54]	 JD148	
HBS051  [22-17001B] M10x1.25x98mm (x5) M10x1.25x84mm (x5) HBS092  [22-17003B] M10x1.25x115mm (x10)	JD146 [31-027221-10]  JF150 [31-027151-00]	JM654 01/89 → 12/93 JN805 [156] [31-026819-00] 01/89 → 12/93 JP049 [31-026820-00] 01/93 →	JJ453	HR363 	 NA5187 (x2) 30x52x7mm, ACM [50-319492-00]  NB818  40x56x7mm, ACM  NA5049  64x80x8mm, ACM  NB808  64x80x8mm, FPM  NA5051  40x56x7mm, FPM	KA293 [13] KA294 [13] KA354 [13] LA378 [53] KT465 [54] JR265 [11] KT754 [11] LR902 [11] KV122 [56]	 JD146	
HBS051  [22-17001B] M10x1.25x98mm (x5) M10x1.25x84mm (x5)	JD146 [31-027221-10]	JP049 [31-026820-00]	JJ453	HR363 	 NA5187 (x2) 30x52x7mm, ACM [50-319492-00]  NB818  40x56x7mm, ACM  NA5049  64x80x8mm, ACM  NA5051  40x56x7mm, FPM		 JN643	
HBS092  [22-17003B] M10x1.25x115mm (x10)							 JN645	
							 JN667	
							 JN805	
							 JP049	
							 JJ298	



KW/PS



Tipo 1.7L D Diesel					01/88 → 10/94	334			
149 B4.000	1697	4	82.60	SOHC		44/60	BT220 (Fibre), 1.65mm (30-025166-10) AC5140 (MLS), 1.66mm (30-026296-20) AC5150 (MLS), 1.76mm (30-026297-20) BT230 (Fibre), 1.80mm, 1 Notch AC5180 (MLS), 1.86mm (30-027859-20) BT240 (Fibre), 1.95mm, 2 Notches (30-025168-10) AC5160 (MLS), 1.96mm (30-026298-20)	DT412 [12] DV680▲ (21-25142-26/0)	EV684 (22-25142-00/0) GV680▲ [100]
Tipo 1.8L i.e.					04/93 → 04/95	335			
835 C2.000	1756	4	84.00	i.e., DOHC		76/103	BT440 (Fibre) (30-026647-30)	DT449 (21-26647-30/0)	GT449 (20-26647-11/0)
Tipo 1.8L i.e.					10/94 → 04/95	336			
159 A4.000	1756	4	84.00	i.e., DOHC		76/103	BT440 (Fibre) (30-026647-30)	DT446 (21-26647-23/0)	GT446 [12] (20-26647-03/0)
Tipo 1.8L i.e.					09/93 → 04/95	337			
835 C4.000	1756	4	84.00	Injection, DOHC		66/89			
Tipo 1.8L i.e.					10/90 → 06/93	338			
159 A4.046	1756	4	84.00	i.e., DOHC		76/103	BT440 (Fibre) (30-026647-30)	DT440	GT440 (20-26647-02/0)
Tipo 1.8L i.e. 16V Sport					11/89 → 06/92	339			
160 A5.000	1756	4	84.00	i.e.		100/136	BT440 (Fibre) (30-026647-30)	DT441 (21-26647-21/0)	GT444 (20-26647-01/0)
Tipo 1.9L D Diesel					07/91 → 08/96	340			
160 A7.000	1929	4	82.60			48/65	BT220 (Fibre), 1.65mm (30-025166-10) AC5140 (MLS), 1.66mm (30-026296-20) AC5150 (MLS), 1.76mm (30-026297-20) BT230 (Fibre), 1.80mm, 1 Notch AC5180 (MLS), 1.86mm (30-027859-20) BT240 (Fibre), 1.95mm, 2 Notches (30-025168-10) AC5160 (MLS), 1.96mm (30-026298-20)	DV680▲ (21-25142-26/0)	EV684 (22-25142-00/0) GV680▲ [100]
Tipo 1.9L TD Diesel					03/92 → 06/93	341			
160 B6.046	1929	4	82.60	SOHC		66/89			











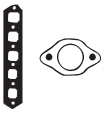

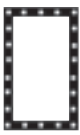

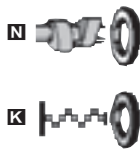











































































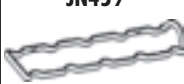



								
HBS095 [22-17007B] M12x1.25x133mm (x10)	JC738 (31-026290-10)	JN459 (31-025142-10)	JJ298 (Cork) (Rubber) JJ398 (31-027379-00)	HR596	NA5187 30x52x7mm, ACM (50-319492-00) NB742 30x43x8mm, ACM (50-319408-00) NB732 74x90x10mm, FPM NA5062 74x90x10mm, ACM	HL5028 [245] [5] KA294 [13] KA556 [13] LT021 [13] [164] LT023 [13] LV583 [53] KT465 [54] LT019 [86] KT639 [11] LV589 [11] LT498 [45] LV582 [45] LV585 [45]	 BT220, BT230, BT240  BT440  JA757  JC662  JC738  JD019  JD151  JD153	
HBS092 [22-17003B] M10x1.25x115mm (x10) 07/92→	JC662 [31-026050-10] JD019 [31-027032-10]	JN819 (x2) JN948 (x2) (31-027428-00)	JJ366 (31-027488-00) JJ413 (31-027315-00)	HR363	NA5187 (x2) 30x52x7mm, ACM (50-319492-00) NB742 30x43x8mm, ACM (50-319408-00) NB732 74x90x10mm, FPM NB825 30x43x8mm, FPM (50-306773-50)	HL5028 [245] [5] LB175 [70] LB025 [13] OK627 [14] KT465 [54] LA055 [56]	 JB175  LB025  OK627  KT465  LA055	
HBS092 [22-17003B] M10x1.25x115mm (x10)	JC662 [31-026050-10] JD019 [31-027032-10] 01/92→	JN643 (x2) (31-027225-00) JN948 (31-027428-00) JN819 (x2) 01/92→	JJ298 (Cork) JJ366 (31-027488-00) JJ413 (31-027315-00)	HR363	NA5187 (x2) 30x52x7mm, ACM (50-319492-00) NB732 74x90x10mm, FPM NB742 30x43x8mm, ACM (50-319408-00) NB825 30x43x8mm, FPM (50-306773-50)	HL5028 [245] [5] LB175 [70] LB025 [13] OK627 [14] HJ283 [39] [5] OK473 [160] LA055 [56]	 JN459  JN819, JN643  JN928  JN948	
HBS092 [22-17003B] M10x1.25x115mm (x10)	JC662 [31-026050-10] JA757 [31-022346-10]	JN643 (x2) (31-027225-00) JN819 (x2) JN948 (31-027428-00)	JJ298 (Cork) JJ366 (31-027488-00) JJ413 (31-027315-00)	HR363	NA5187 (x2) 30x52x7mm, ACM (50-319492-00) NB742 30x43x8mm, ACM (50-319408-00) NB732 74x90x10mm, FPM	HL5028 [245] [5] LB175 [70] LB025 [13] OK627 [14] KT465 [54] OK473 [160] LA055 [56]	 JJ298  JJ366	
HBS093 [22-17005B] M10x1.25x172mm (x10)	JD153 [31-027321-00] JD151 [31-027331-00]	JN928 [102] (50-027319-00)	JJ413 (31-027315-00)		NA5187 (x2) 30x52x7mm, ACM (50-319492-00) NA5053 30x42x7mm, FPM (50-319488-00) NB742 30x43x8mm, ACM (50-319408-00) NA5062 74x90x10mm, ACM	JS081 [11] KT639 [11]	 JJ366  JJ398  JJ413	
HBS095 [22-17007B] M12x1.25x133mm (x10)	JC738 (31-026290-10)	JN459 (31-025142-10)	JJ298 (Cork) JJ398 (31-027379-00)	HR596	NA5187 30x52x7mm, ACM (50-319492-00) NB742 30x43x8mm, ACM (50-319408-00) NB732 74x90x10mm, FPM	HL5028 [245] [5] LB175 [70] LV586 [70] LT021 [13] [164] LV583 [53] LT498 [45] LV585 [45]	 JJ398  JJ413	
HBS095 [22-17007B] M12x1.25x133mm (x10)						LV586 [70] LT498 [45]		



KW/PS



Tipo 1.9L TD Diesel				09/90 → 04/95	342			
160 A6.000/160	1929	4	82.60	SOHC	66/89	BR680 (Graphite), 1.65mm AC5140 (MLS), 1.66mm (30-026296-20) BV680 (Fibre), 1.67mm, 0 Notches (30-026296-10) BV690 (Fibre), 1.75mm, 1 Notch AC5150 (MLS), 1.76mm (30-026297-20) BV700 (Fibre), 1.85mm, 2 Notches (30-027859-00) AC5180 (MLS), 1.86mm (30-027859-20) BW980 (Fibre), 1.93mm, 3 Notches AC5160 (MLS), 1.96mm (30-026298-20)	DV680▲ (21-25142-26/0)	EV684 (22-25142-00/0) GV680▲ [100]
A6.046								
160 D1.000	1929	4	82.60	SOHC	68/92			
Tipo 2.0L 16V				07/91 → 04/95	343			
160 A8.046	1995	4	84.00	DOHC	107/146			
Tipo 2.0L i.e.				06/90 → 03/92	344			
159 A5.046	1995	4	84.00	Injection, DOHC	80-85/ 109- 116		DT440	
Tipo 2.0L i.e.				03/90 → 04/95	345			
159 A6.046	1995	4	84.00	i.e., DOHC	83-85/ 113- 116	BT440 (Fibre) (30-026647-30)	DT449 (21-26647-30/0) GT449 (20-26647-11/0)	
Tipo 2.0L i.e. 16V Sport				03/93 → 04/95	346			
836 A3.000	1995	4	84.00	injection	109/148	BT440 (Fibre) (30-026647-30)	DT448 GT448	
Ulysse 1.8L				05/97 → 08/02	347			
LFW (XU7 JP)	1762	4	83.00	SPi, SOHC	73/99	BL650 (Fibre), 1.20mm (30-026859-10) BR510 (Fibre), 1.44mm [34] (30-026858-10)	CY131▲ (21-25204-24/0) EL650 (22-25198-00/0)	
Ulysse 1.9L TD Diesel				02/95 → 08/02	348			
D8B/XUD9TF/L (DHX)	1905	4	83.00	SOHC, Turbo	66/89	BX930 (Steel Elastomer), 1.36mm, 1 Notch (30-028503-00) BX940 (Steel Elastomer), 1.40mm, 2 Notches (30-028504-00) BX950 (Steel Elastomer), 1.44mm, 3 Notches (30-028505-00) BX960 (Steel Elastomer), 1.48mm, 4 Notches (30-028506-00) BX970 (Steel Elastomer), 1.52mm, 5 Notches (30-028507-00) BX980 (Steel Elastomer), 1.59mm 0.83mm →	DJ720▲ (21-25202-22/0)	EL890 (22-25198-01/0) GJ720▲ (20-25202-02/0)
XUD9TF/L (DHX)	1905	4	83.00	SOHC	66/89			
Ulysse 2.0L D Multijet Diesel				05/06 →	349			
RHK/RHR	1997	4	85.00	Direct Injection, DOHC			CD5500▲ ED5500	
Ulysse 2.0L				08/02 →	350			
RFN(EW10J4)	1997	4	85.00	DOHC	100/136	AD5300 (MLS) RFN(EW10J4)	CD5300	

								
HBS095  (22-17007B) M12x1.25x133mm (x10)	JC738 (31-026290-10)	JN459 (31-025142-10)	JJ298 (Cork) JJ398 (31-027379-00)	HR363  HR596 	NA5187 30x52x7mm, ACM (50-319492-00) NB742  30x43x8mm, ACM (50-319408-00) NB732  74x90x10mm, FPM NA5062  74x90x10mm, ACM	LB175 [70] LV586 [70] LT021 [13] [164] LV583 [53] HJ283 [39]  KT465 [54] JR749 [11] JS081 [11] LV589 [11] LV582 [45] LV585 [45]	 AC5140, AC5150, AC5180, AC5160  BL650  BR680  BT440  BV680, BV690, BV700, BW980  BX930, BX940, BX950, BX960, BX970, BX980	 JN948  JJ283  JJ298  JJ366  JJ398  JJ413
HBS093  (22-17005B) M10x1.25x172mm (x10)								
HBS092  (22-17003B) M10x1.25x115mm (x10)					NA5187 (x2) 30x52x7mm, ACM (50-319492-00)			
HBS093  (22-17005B) M10x1.25x172mm (x10)	JC662  (31-026050-10) JD019  (31-027032-10)	JN643 (31-027225-00) JN819 JN948 (31-027428-00)	JJ298 (Cork) JJ366 (31-027488-00) JJ413 (31-027315-00)	HR363 	NA5187 (x2) 30x52x7mm, ACM (50-319492-00) NB742  30x43x8mm, ACM (50-319408-00) NB732  74x90x10mm, FPM NB825  30x43x8mm, FPM (50-306773-50) NA5062  74x90x10mm, ACM	HL5028 [245]  LB175 [70] LB025 [13] [159] OK627 [14] HJ283 [39]  OK473 [160] LA055 [56]	 JC415  JC662  JC738  JC991  JD019  JD151  JD153  JD519  JD536  JD539	
HBS093  (22-17005B) M10x1.25x172mm (x10)	JD153  (31-027321-00) JD151 (31-027331-00)	JN928 [102] (50-027319-00)	JJ413 (31-027315-00)	HR800 	NA5053 30x42x7mm, FPM (50-319488-00) NB742  30x43x8mm, ACM (50-319408-00) NB732  74x90x10mm, FPM NA5062  74x90x10mm, ACM	JS081 [11]	 JD151  JD153  JD519  JD536  JD539	
HBS260  (22-53011B) M11x1.50x168mm (x10)	JD519  JC415  (31-025205-20)	JN547 (50-025204-10)	JJ283 [6] (31-025198-10) = PB907 14x21x2mm		NF817 36x50x7mm, FPM (50-319112-00) NA5191  42x62x7mm, PTFE (50-319500-00) NA5192  90x110x7mm, PTFE (50-319501-00)	HL5019 [245]  HR566 [37]  NF836 [38]  NF826 [38]  KA611 [13]	 JD519  JD536  JD539	
HBS088  (22-15014B) M12x1.50x145mm (x10) HBS277  (22-53018B) M12x1.50x148mm (x10)	JC991 (31-028595-00)	JN544 (50-025202-00)	JJ283 [6] (31-025198-10) = PA349 (33-102290-10) 22x16x2mm = PB907 14x21x2mm	HR569  24-30667-00/0	NF841 35x50x8mm, FPM (50-319310-00) NB959  35x50x7mm, FPM (50-306644-50) NA5191  42x62x7mm, PTFE (50-319500-00) NA5192  90x110x7mm, PTFE (50-319501-00)	HL5010 [245]  NF836 [38]  NF826 [38]  KA611 [13]	 JN459  JN544  JN547  JN643, JN819  JN928	
	JD5881 	HM5289 						
HBS259  (22-53010B) M11x1.50x144.5mm (x10)	JD536  → Eng.07328 JD5833  JD539  (x4)	JM5283   JM5139  						



KW/PS



Ulysse 2.0L					06/94 → 08/02	351	BV140 (Fibre), 1.25mm (30-028760-00) BY320 (Fibre), 1.45mm [34]	CY082▲ (21-25204-23/0)	ES820 (22-25198-03/0)
RFU (XU10 J2C)	1998	4	86.00	MPI, SOHC		88/120			
Ulysse 2.0L 16V					05/98 → 09/00	352	AY070 (Fibre) (30-029744-00)		
XU10 (RFV)	1998	4	86.00	Injection, DOHC		99/135			
Ulysse 2.0L 16V					09/00 → 08/02	353	AD5300 (MLS) RFN(EW10J4)		
EW10J4 (RFN)	1998	4	85.00	DOHC		100/136			
Ulysse 2.0L JTD Diesel					10/99 → 08/02	354	AC5011 (MLS), 1.30mm, 1 Hole ⊖0.47 → 0.605mm AC5020 (MLS), 1.35mm, 2 Holes (30-029478-00) ⊖0.605 → 0.655mm AC5031 (MLS), 1.40mm, 3 Holes (30-029479-10) ⊖0.655 → 0.705mm AC5040 (MLS), 1.45mm, 4 Holes (30-029480-00) ⊖0.705 → 0.755mm AC5051 (MLS), 1.50mm, 5 Holes (30-029481-10) ⊖0.755 → 0.83mm	CC5010▲ (21-29484-20/0)	
DW10 (RHZ)	1998	4	85.00	Common Rail, SOHC		66/89			
Ulysse 2.0L JTD Diesel					08/02 →	355	AD5490 (MLS), 1.25mm (30-029789-00) AD5500 (MLS), 1.30mm (30-029790-00) AD5510 (MLS), 1.35mm (30-029791-00) AD5520 (MLS), 1.40mm (30-029792-00)		
DW10ATED4 (RHS)	1998	4	85.00	Common Rail, DOHC		80/109			
Ulysse 2.0L JTD Diesel					05/03 →	356	AC5011 (MLS), 1.30mm, 1 Hole ⊖0.47 → 0.605mm AC5020 (MLS), 1.35mm, 2 Holes (30-029478-00) ⊖0.605 → 0.655mm AC5040 (MLS), 1.45mm, 4 Holes (30-029480-00) ⊖0.705 → 0.755mm	CC5010▲ (21-29484-20/0)	
DW10ATED4 (RHM)	1997	4	85.00	Direct Injection, DOHC		79/107			

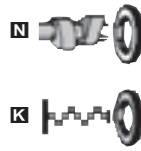
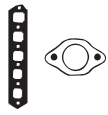

AC5020, AC5040



AD5490, AD5500,
AD5510, AD5520



AY070



BV140, BY320



JJ283











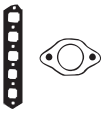

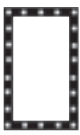

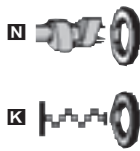

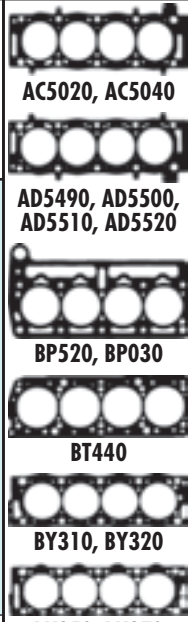



























<p>HBS084 </p> <p>(22-15005B)</p> <p>M12x1.50x123mm (x10)</p>			<p>JJ283 [6]</p> <p>(31-025198-10)</p> <p>(Steel)</p> <p>≡ PA349</p> <p>(33-102290-10)</p> <p>22x16x2mm</p> <p>≡ PB907</p> <p>14x21x2mm</p>		<p> NF817 36x50x7mm, FPM (50-319112-00)</p> <p> NA5191 42x62x7mm, PTFE (50-319500-00)</p> <p> NA5192 90x110x7mm, PTFE (50-319501-00)</p>	<p>HL5019 [245] </p> <p>NF836 [38] </p> <p>NF826 [38] </p> <p>KA611 [13]</p>
<p>HBS087 </p> <p>(22-15013B)</p> <p>M12x1.50x110mm (x10)</p> <p>→Eng.08581</p> <p>HBS278 </p> <p>(22-53019B)</p> <p>M12x1.50x110mm (x10)</p> <p>Eng.08582→</p>						
<p>HBS259 </p> <p>(22-53010B)</p> <p>M11x1.50x144.5mm (x10)</p>	<p>JD5833 </p>	<p>JM5283 </p> <p>JM5139 </p>				
<p>HBS261 </p> <p>(22-53014B)</p> <p>M12x1.50x131mm (x10)</p>	<p>JD5191 </p> <p>JD5190 </p>	<p>JM5087</p>	<p>≡ KG5157</p> <p>10x20x2mm</p> <p>≡ PB907</p> <p>14x21x2mm</p>	<p>HR5064 </p> <p>(24-31935-10/0)</p>	<p> NA5035 27x47x7mm, FPM (50-319474-00)</p> <p> NA5191 42x62x7mm, PTFE (50-319500-00)</p> <p> NA5192 90x110x7mm, PTFE (50-319501-00)</p>	<p>HL5016 [245] </p>
<p>HBS261 </p> <p>(22-53014B)</p> <p>M12x1.50x131mm (x10)</p>		<p>JM5141</p> <p>(50-030271-00)</p>		<p>HR5046 </p>	<p> NA5035 27x47x7mm, FPM (50-319474-00)</p> <p> NA5191 42x62x7mm, PTFE (50-319500-00)</p> <p> NA5192 90x110x7mm, PTFE (50-319501-00)</p>	<p>HL5016 [245] </p>
<p>HBS261 </p> <p>(22-53014B)</p> <p>M12x1.50x131mm (x10)</p>				<p>HR5064 </p> <p>(24-31935-10/0)</p>	<p> NA5035 27x47x7mm, FPM (50-319474-00)</p> <p> NA5191 42x62x7mm, PTFE (50-319500-00)</p> <p> NA5192 90x110x7mm, PTFE (50-319501-00)</p>	<p>HL5016 [245] </p>



KW/PS



Ulysse 2.0L JTD Diesel		12/99 →		357				
DW10ATED4 (RHS)	1998	4	85.00	Common Rail, DOHC, Turbo	80/109	AC5011 (MLS), 1.30mm, 1 Hole ↳0.47→0.605mm AC5020 (MLS), 1.35mm, 2 Holes (30-029478-00) ↳0.605→0.655mm AC5031 (MLS), 1.40mm, 3 Holes (30-029479-10) ↳0.655→0.705mm AC5040 (MLS), 1.45mm, 4 Holes (30-029480-00) ↳0.705→0.755mm AC5051 (MLS), 1.50mm, 5 Holes (30-029481-10) ↳0.755→0.83mm	CC5010▲ (21-29484-20/0)	
Ulysse 2.0L Turbo		06/94 →08/02		358				
RGX	1998	4	86.00		108/147	BT440 (Fibre) (30-026647-30) BY310 (Fibre), 1.25mm (30-028761-00) BY320 (Fibre), 1.45mm [34]	DY310▲ (21-25204-25/0)	ES820 (22-25198-03/0)
Ulysse 2.1L TD Diesel		03/96 →10/99		359				
P8C (XUD 11 BTE)	2088	4	85.00	SOHC	80/109	BY941 (MLS), 1.52mm (30-027543-20) ↳0.65→0.76mm BY950 (MLS), 1.57mm (30-027544-10) ↳0.77→0.81mm BY970 (MLS), 1.67mm [68] (30-028713-00) BY961 (MLS), 1.62mm (30-028712-10) 10/94 → ↳0.82→0.86mm BY981 (MLS), 1.72mm (30-028714-10) 10/94 → ↳0.92→0.96mm	DV150▲ (21-27540-20/0)	EV150 (22-25198-02/0)
Ulysse 2.2L JTD Diesel		08/02 →		360				
4HW (DW12ATED4)	2179	4	85.00	Direct Injection, DOHC	94/128	AD5490 (MLS), 1.25mm (30-029789-00) AD5500 (MLS), 1.30mm (30-029790-00) AD5510 (MLS), 1.35mm (30-029791-00) AD5520 (MLS), 1.40mm (30-029792-00)	CD5490▲ (21-29789-20/0)	ED5490 (22-29789-00/0)
Ulysse 3.0L V6		08/02 →		361				
XFW	2946	6	87.00	DOHC, V6	150- 152/ 204- 207	AH5060 (MLS), 0.74mm ▣ AH5070 (MLS), 0.95mm ▣ AH5040 (MLS), 0.74mm ▣ AH5050 (MLS), 0.95mm ▣	CH5060▣ CH5040▣	
Uno 0.9L 45		03/83 →09/92		362				
146 A.000/146 A.1000	903	4	65.00	SOHC	33/45	BP520 (Fibre), 1.20mm (30-026522-20) BP030 (Fibre), 1.80mm (30-025210-20)	CG01A▲ →Eng.8064870 DP011■ [153] (21-26522-20/0) →Eng.8064870 DR610 [154] →Eng.8064870	GP011 →Eng.8064870











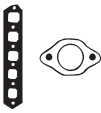

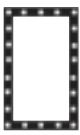

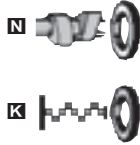

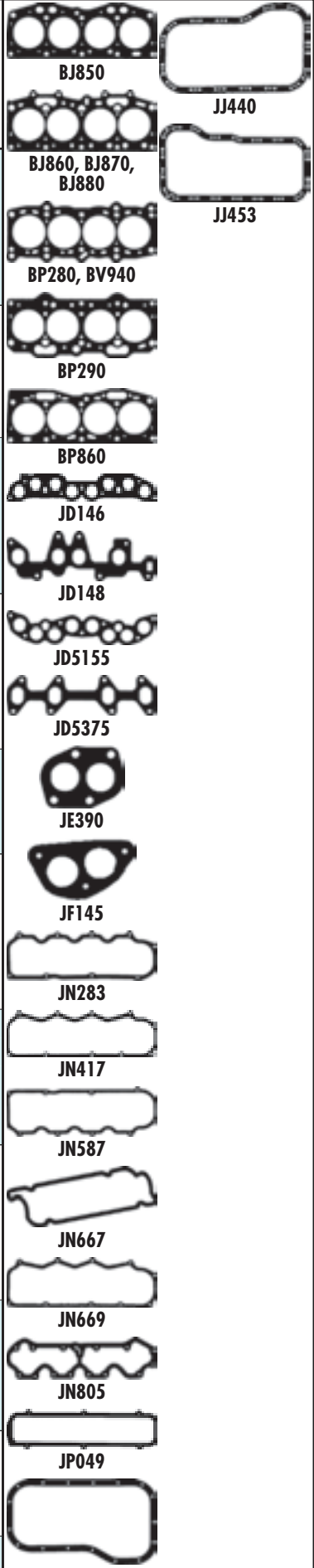





















































								
HBS261  (22-53014B) M12x1.50x131mm (x10)	JD5191  JD5190 	JM5087	KG5157 10x20x2mm PB907 14x21x2mm	HR5046 	NA5035 27x47x7mm, FPM (50-319474-00) NA5191  42x62x7mm, PTFE (50-319500-00) NA5192  90x110x7mm, PTFE (50-319501-00)	HL5016 [245] 		ACS020, ACS040 AD5490, AD5500, AD5510, AD5520 BP520, BP030 BT440 BY310, BY320 BY950, BY970
HBS084  (22-15005B) M12x1.50x123mm (x10)	JD153  (31-027321-00) JD151 (31-027331-00)	JN547 (50-025204-10)	JJ283 [6] (31-025198-10)		NF817 36x50x7mm, FPM (50-319112-00) NA5191  42x62x7mm, PTFE (50-319500-00) NA5192  90x110x7mm, PTFE (50-319501-00)	HL5019 [245]  LB175 [70] LB025 [13] [159] JR749 [11] JS081 [11] KT639 [11] OK473 [160] LA055 [56]		JC973 JD151 JD153
HBS125  (22-15007B) M12x1.50x150.5mm (x10)	JD529  (31-027540-00) JD230 	JP045 (50-028922-00)	JJ283 [6] (31-025198-10) (Steel) PA349 (33-102290-10) 22x16x2mm PB907 14x21x2mm	HR805 	NF841 35x50x8mm, FPM (50-319310-00) NA5191  42x62x7mm, PTFE (50-319500-00) NA5192  90x110x7mm, PTFE (50-319501-00)	HL5010 [245]  NF824 [38]  NF825 [38]  KA611 [13]		JD230 JD529 JM333 JN547 JP045 HC027 JJ283
HBS261  (22-53014B) M12x1.50x131mm (x10)		JM5141 (50-030271-00)		HR5046 	NA5035 27x47x7mm, FPM (50-319474-00) NA5191  42x62x7mm, PTFE (50-319500-00) NA5192  90x110x7mm, PTFE (50-319501-00)	HL5016 [245] 		
HBS272  (22-53016B) M10x1.50x147mm (x16)	JD5906  JD5907  (x2) JE5069 JE5070 JE5071							
HBS109  (22-17009B) M9x1.25x60mm (x1) M9x1.25x95mm (x9)	JC973  (31-021833-10)	JM333 (31-021029-00)	HC027  (23-17373-01/0) → Eng.8064870	HR599  (24-31919-10/0)	NB633  42x63x7mm, ACM (50-319184-00) NA5049  64x80x8mm, ACM NB808  64x80x8mm, FPM	HJ274 [39]  KD226 [91] KD747 [91] JR154 [11] JR556 [11]		



KW/PS



Uno 0.9L Super D Diesel				01/81 → 12/83	363	BJ860 (Fibre), 1.65mm (30-026451-10) BJ870 (Fibre), 1.80mm, 1 Notch (30-026452-10) BJ880 (Fibre), 1.95mm, 2 Notches (30-026453-10)	DJ872▲ (21-25319-21/0)	GJ872▲		
127 A5.000	1301	4	76.00		33/44					
Uno 1.0L				→ 01/91	364	BP290 (Fibre) (30-025345-10)	DP293 (21-25345-22/0) → 01/91 DP294 01/91 →	GP293 → 01/91 GP294 01/91 →		
146C.7000	994	4	76.00							
Uno 1.0L 45				06/86 → 12/93	365	BP280 (Fibre), 1.65mm (30-026046-30) BV940 (Fibre), 2.00mm (30-028799-00)	CV940 [170] (21-28799-21/0) DV675 (21-27185-00/0)	GP282 [171] (20-26046-00/0)		
156 A2.048	999	4	70.00	SOHC	32/44					
156 A2.100	999	4	70.00	SOHC	41/55					
Uno 1.0L i.e. 45				04/84 → 12/94	366	BP280 (Fibre), 1.65mm (30-026046-30) BV940 (Fibre), 2.00mm (30-028799-00)	DV675 (21-27185-00/0)	GP282 [171] (20-26046-00/0)		
156 A2.246	999	4	70.00	SPI, SOHC	33/45					
Uno 1.1L 50				01/86 → 12/89	367	BJ850 (Fibre) (30-024779-10)	DJ851▲ DJ852 (21-24779-21/0)			
146 A4.044	1116	4	80.00	SOHC	41/55					
Uno 1.1L 50				01/90 → 12/93	368	BP280 (Fibre), 1.65mm (30-026046-30) BV940 (Fibre), 2.00mm (30-028799-00)	DV675 (21-27185-00/0)	GP282 [171] (20-26046-00/0)		
156 C.046	1108	4	70.00	SPI, SOHC	37-43/ 50-58					
Uno 1.1L 55				01/83 → 08/89	369	BJ850 (Fibre) (30-024779-10)	DJ851▲ DJ852 (21-24779-21/0)	GJ852		
Uno 1.1L 60 S/SL				01/83 →						
Uno 1.1L Selecta				01/83 →						
138 B.000	1116	4	80.00		41/55					
Uno 1.1L 60				04/89 → 12/92	370	BP280 (Fibre), 1.65mm (30-026046-30) BV940 (Fibre), 2.00mm (30-028799-00)	CV940 [170] (21-28799-21/0) DV675 (21-27185-00/0)	GP282 [171] (20-26046-00/0)		
160 A3.000	1108	4	70.00		41/55					
Uno 1.1L 60				05/85 → 08/89	371	BJ850 (Fibre) (30-024779-10)	DJ851▲ DJ852 (21-24779-21/0)	GJ852		
146 A4.048	1116	4	80.00	SOHC	41/55					
Uno 1.1L i.e. 50				06/92 → 12/93	372	BP280 (Fibre), 1.65mm (30-026046-30) BV940 (Fibre), 2.00mm (30-028799-00)	DV675 (21-27185-00/0)			
146 C3.000	1116	4	80.00	SOHC	36/49					
Uno 1.3L 70				01/83 → 08/89	373	BP860 (Fibre) (30-025893-10)	DJ851▲ → Eng.5750056 DP871 (21-25894-22/0) → Eng.5750056	GP871 (20-25894-03/0) → Eng.5750056		
138 B2.000	1302	4	86.40		50/68					
149 A7.000	1302	4	86.40	SOHC	50/68					











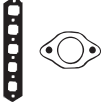

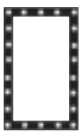



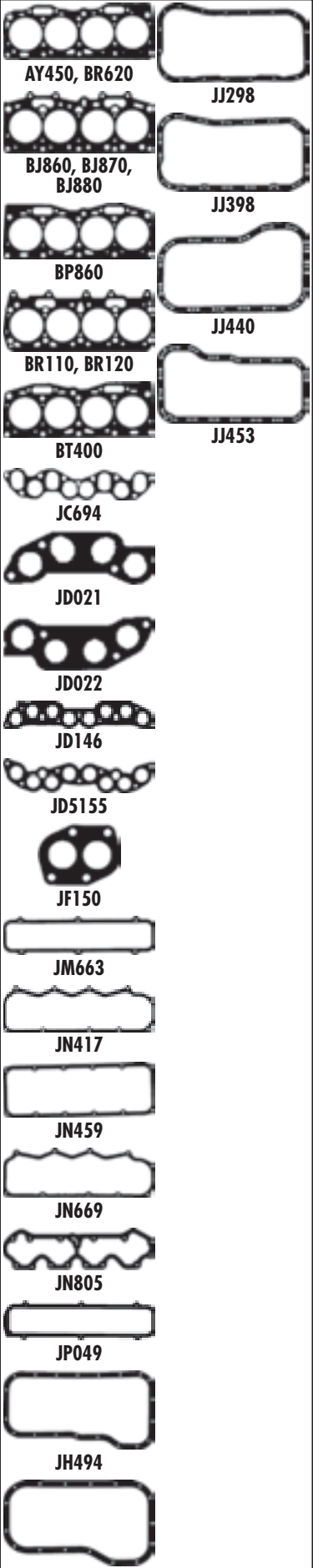























































								
		JD5155 (31-029308-00)	JN417 JN669 (31-025319-00) (Cork)	JJ078 JJ440 (31-027495-00)	HR596 	NA5187  30x52x7mm, ACM (50-319492-00) NA5051  40x56x7mm, FPM NA5052  70x85x8mm, FPM	KD717 [91]	BJ850 BJ860, BJ870, BJ880 BP280, BV940
		JD5155 (31-029308-00)	JN283 →01/91 JN587 01/91→	JJ078 JJ440 (31-027495-00)	HR596 	NA5187  30x52x7mm, ACM (50-319492-00) NA5051  40x56x7mm, FPM NB730  70x85x8mm, FPM		JJ440 JJ453
HBS052  (22-17006B) M9x1.25x95mm (x10)	JD148  (31-025907-10) JD5375  (x2) (31-029968-00) JF145 (MLS)	JN667 (50-026094-00) JN667C1 (Rubber)	HR354 [94]	HR599  (24-31919-10/0)	NA5053  30x42x7mm, FPM (50-319488-00) NB815  23x35x7mm, FPM (50-319523-00) NB814  70x88x8mm, FPM (50-306350-50)	HL5024 [245]  KA5032 [53] LV695 [53] HJ280 [39]  JR673 [11] LB177 [46]	BP860 JD146 JD148 JD5155 JD5375 JE390 JF145 JN283 JN417 JN587 JN667 JN669 JN805 JP049	
HBS052  (22-17006B) M9x1.25x95mm (x10)	JD148  (31-025907-10) JD5375  (x2) (31-029968-00) JF145 (MLS)	JN667 (50-026094-00) JN667C1 (Rubber)	HR354 [94]	HR599  (24-31919-10/0)	NA5053  30x42x7mm, FPM (50-319488-00) NB815  23x35x7mm, FPM (50-319523-00) NB814  70x88x8mm, FPM (50-306350-50)	HL5024 [245]  KA5032 [53] LV695 [53] HJ280 [39]  JR673 [11] LB177 [46]	BP860 JD146 JD148 JD5155 JD5375 JE390 JF145 JN283 JN417 JN587 JN667 JN669 JN805 JP049	
HBS051  (22-17001B) M10x1.25x98mm (x5) M10x1.25x84mm (x5)					NA5187  30x52x7mm, ACM (50-319492-00)		JE390 JF145 JN283 JN417 JN587 JN667 JN669 JN805 JP049	
HBS052  (22-17006B) M9x1.25x95mm (x10)	JD148  (31-025907-10) JD5375  (x2) (31-029968-00) JF145 (MLS)	JN667 (50-026094-00) JN667C1 (Rubber)	HR354 [94]	HR599  (24-31919-10/0)	NA5053  30x42x7mm, FPM (50-319488-00) NB815  23x35x7mm, FPM (50-319523-00) NB814  70x88x8mm, FPM (50-306350-50)	HL5024 [245]  KA5032 [53] LV695 [53] HJ280 [39]  JR673 [11] LB177 [46]	JE390 JF145 JN283 JN417 JN587 JN667 JN669 JN805 JP049	
HBS051  (22-17001B) M10x1.25x98mm (x5) M10x1.25x84mm (x5)	JD146 (31-027221-10)	JM654 JN805 [156] (31-026819-00) JP049 (31-026820-00)	JJ453	HR596 	NA5187  30x52x7mm, ACM (50-319492-00) NB818  40x56x7mm, ACM NA5049  64x80x8mm, ACM	KA293 [13] KT465 [54] KD717 [91]	JN283 JN417 JN587 JN667 JN669 JN805 JP049	
HBS052  (22-17006B) M9x1.25x95mm (x10)	JD148  (31-025907-10) JD5375  (x2) (31-029968-00)	JN667 (50-026094-00) JN667C1 (Rubber)	HR354 [94]	HR599  (24-31919-10/0)	NA5053  30x42x7mm, FPM (50-319488-00) NB815  23x35x7mm, FPM (50-319523-00) NB814  70x88x8mm, FPM (50-306350-50)	KA5032 [53]	JN283 JN417 JN587 JN667 JN669 JN805 JP049	
HBS051  (22-17001B) M10x1.25x98mm (x5) M10x1.25x84mm (x5)	JD146 (31-027221-10)	JM654 JN805 [156] (31-026819-00) JP049 (31-026820-00)	JJ453	HR596 	NA5187  30x52x7mm, ACM (50-319492-00) NB818  40x56x7mm, ACM NA5049  64x80x8mm, ACM	KA293 [13] KA294 [13] KH029 [53] KT465 [54] KD717 [91]	JN283 JN417 JN587 JN667 JN669 JN805 JP049	
HBS051  (22-17001B) M10x1.25x98mm (x5) M10x1.25x84mm (x5)					NA5053  30x42x7mm, FPM (50-319488-00)		JP049	
HBS051  (22-17001B) M10x1.25x98mm (x5) M10x1.25x84mm (x5)	JD146 (31-027221-10) JE390  (31-021632-10)	JM654 JN805 [156] (31-026819-00) JP049 (31-026820-00)	JJ453	HR596 	NA5187  30x52x7mm, ACM (50-319492-00) NB818  40x56x7mm, ACM NA5049  64x80x8mm, ACM	KA293 [13] KA294 [13] HJ279 [39] [48]  KT465 [54]	JJ078	



KW/PS



Uno 1.3L D R/89 Diesel		01/81 → 12/83		374		BJ860 (Fibre), 1.65mm (30-026451-10)	DJ872▲ (21-25319-21/0)	GJ872▲
Uno 1.3L Super D Diesel		06/83 → 03/92				BJ870 (Fibre), 1.80mm, 1 Notch (30-026452-10)		
127 A5.000/ 146 B1.000/146 B1.000	1301	4	76.00		33/44	BJ880 (Fibre), 1.95mm, 2 Notches (30-026453-10)		
Uno 1.3L i.e. Turbo		01/87 → 03/91		375		BP300 (Fibre) (30-025351-10)	DP301	GP301 [12]
146 A2.146/146 A2.246	1301	4	80.50	Injection, SOHC	77/105			
Uno 1.3L i.e. Turbo		04/85 → 08/89		376		BP300 (Fibre) (30-025351-10)	DP301	GP301 [12]
146 A2.000	1301	4	80.50	Injection, SOHC	77/105			
Uno 1.4L 70 Sxi		01/90 →		377		AY450 (Fibre) [249] BR620 (Fibre) [249] (30-027865-00)	DR620 (21-26295-21/0)	GR620
146 C1.000/146 D5.000	1372	4	80.50	SOHC	51-53/ 69-72			
Uno 1.4L i.e. 70		09/89 → 12/93		378		AY450 (Fibre) [249] BR620 (Fibre) [249] (30-027865-00)	DR620 (21-26295-21/0)	GR620
160 A1.046	1372	4	80.50	SOHC	51/69			
Uno 1.4L i.e. Turbo		12/89 → 12/96		379		BP300 (Fibre) (30-025351-10) BT400 (Fibre) (30-026693-10) 146A8.000	DP301 DT400■ (21-26693-20/0) 146A8.000	GP301 [12] GT400■ 146A8.000
146 A8.000	1372	4	80.50	SOHC	82-87/ 112- 118			
Uno 1.4L i.e. Turbo		09/89 → 09/93		380		BT400 (Fibre) (30-026693-10)	DT400■ (21-26693-20/0)	GT400■
146 A8.046	1372	4	80.50	Injection, SOHC	82/111			
Uno 1.4L S 70		09/89 → 10/92		381		AY450 (Fibre) [249] 160A1.048 BP300 (Fibre) (30-025351-10) BR620 (Fibre) [249] (30-027865-00) 160A1.048	DP301 DR620 (21-26295-21/0) 160A1.048	GP301 [12] GR620 160A1.048
160 A1.048	1372	4	80.50		52/71			
Uno 1.4L TD 70 Diesel		10/86 → 10/90		382		BR110 (Fibre), 1.92mm, 1 Notch (30-025682-10) BR120 (Fibre), 2.09mm, 2 Notches (30-025683-10)	DR100▲ (21-25142-23/0)	GR100▲ (20-25142-05/0)
146 B.000/146 B3.000	1367	4	78.00	SOHC	51/53/ 69/70			
Uno 1.5L i.e. 75		10/85 → 12/93		383		BP860 (Fibre) (30-025893-10) 01/86 → Eng.5771240 →	DP860 (21-25893-23/0) 01/86 → Eng.5771240 →	GP861 (20-25893-02/0)
138 C2.048 149 C1.000	1498 1498	4 4	86.40 86.40	i.e., SOHC SOHC	55/75 55/75			

								
		JD5155 (31-029308-00)	JN417 JN669 (31-025319-00) (Cork)	JJ078 JJ440 (31-027495-00)	HR596 	 NA5187 30x52x7mm, ACM (50-319492-00)  NA5051  40x56x7mm, FPM  NA5052  70x85x8mm, FPM	KA294 [13] KH029 [53] LA163 [53] LS488 [53] HJ274 [39]  KD717 [91] JR556 [11] KV365 [155]	AY450, BR620 BJ860, BJ870, BJ880 BP860 BR110, BR120 BT400 JJ298 JJ398 JJ440 JJ453
HBS051  (22-17001B) M10x1.25x98mm (x5) M10x1.25x84mm (x5)		JM663 (31-024732-00) JN805 [156] (31-026819-00)	JH494 (31-022554-00) JJ453					KA294 [13] KA294 [13]
HBS051  (22-17001B) M10x1.25x98mm (x5) M10x1.25x84mm (x5)	LT439  (31-025935-10) JD021 (x2) (31-026455-10)	JM654 JM663 (31-024732-00) JN805 [156] (31-026819-00)	JH494 (31-022554-00) JJ453	HR363 	 NA5187 (x2) 30x52x7mm, ACM (50-319492-00)  NB818  40x56x7mm, ACM	KA293 [13] KA294 [13]	JC694 JD021 JD022 JD146 JD5155 JF150	
HBS051  (22-17001B) M10x1.25x98mm (x5) M10x1.25x84mm (x5)	JD146 (31-027221-10)  JF150 (31-027151-00)	JM654 JN805 [156] (31-026819-00) JP049 (31-026820-00)	JJ453	HR363 	 NA5187 (x2) 30x52x7mm, ACM (50-319492-00)  NB818  40x56x7mm, ACM	KA293 [13] KA294 [13] KA354 [13] LA378 [53] KT465 [54]	JD146 JD5155 JF150	
HBS051  (22-17001B) M10x1.25x98mm (x5) M10x1.25x84mm (x5)	JD146 (31-027221-10)	JP049 (31-026820-00)	JJ453	HR363 	 NA5187 (x2) 30x52x7mm, ACM (50-319492-00)  NB818  40x56x7mm, ACM  NB808  64x80x8mm, FPM  NA5051  40x56x7mm, FPM	KT754 [11] KV122 [56]	JD146 JD5155 JF150	
HBS051  (22-17001B) M10x1.25x98mm (x5) M10x1.25x84mm (x5) 146A8.000	LT439  (31-025935-10) 146A8.000 JD022 146A8.000	JM663 (31-024732-00) JN805 [156] (31-026819-00) JP049 (31-026820-00) 146A8.000	JH494 (31-022554-00) JJ453 146A8.000	HR363 	 NA5187 30x52x7mm, ACM (50-319492-00)  NB818  40x56x7mm, ACM  NA5051  40x56x7mm, FPM	KA294 [13] 146A8.000 KT465 [54] 146A8.000 KT754 [11] 146A8.000 KV122 [56] 146A8.000	JM663 JN417	
HBS051  (22-17001B) M10x1.25x98mm (x5) M10x1.25x84mm (x5)	LT439  (31-025935-10) JD022	JP049 (31-026820-00)	JJ453	HR363 	 NA5187 30x52x7mm, ACM (50-319492-00)  NB818  40x56x7mm, ACM	KA294 [13] KT465 [54] KT754 [11] KV122 [56]	JN417 JN459	
HBS051  (22-17001B) M10x1.25x98mm (x5) M10x1.25x84mm (x5) 160A1.048	JD146 (31-027221-10) 160A1.048	JM663 (31-024732-00) JN805 [156] (31-026819-00) JP049 (31-026820-00) 160A1.048	JH494 (31-022554-00) JJ453 160A1.048	HR363  160A1.048	 NA5187 (x2) 30x52x7mm, ACM (50-319492-00)  NB818  40x56x7mm, ACM  NB808  64x80x8mm, FPM	KT754 [11] 160A1.048 KV122 [56] 160A1.048	JN669 JN805	
HBS095  (22-17007B) M12x1.25x133mm (x10)	JC694 (31-025774-10)	JN459 (31-025142-10)	JJ298 (Cork) JJ398 (31-027379-00)	HR596 	 NA5187 30x52x7mm, ACM (50-319492-00)  NB742  30x43x8mm, ACM (50-319408-00)  NA5050  70x90x10mm, ACM	LT021 [13] [164] LT023 [13] LV583 [53] HJ274 [39]  KT465 [54] LT019 [86] LV589 [11] LV582 [45]	JH494	
HBS051  (22-17001B) M10x1.25x98mm (x5) M10x1.25x84mm (x5)	JD146 (31-027221-10)	JM663 (31-024732-00)	JH494 (31-022554-00)	HR596 	 NA5187 30x52x7mm, ACM (50-319492-00)  NB818  40x56x7mm, ACM  NA5049  64x80x8mm, ACM	KA294 [13] HJ279 [39] [48]  KT465 [54] KV122 [56]	JJ078	

FIAT





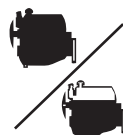













KW/PS



















Uno 1.6L					12/89 → 12/93	384	BP300 (Fibre) (30-025351-10)	DP301	ET400 GP301 [12]
159 A3.046	1585	4	86.40	SOHC		57-62/ 78-84			
Uno 1.7LD 60 Diesel					07/86 → 12/93	385	BT220 (Fibre), 1.65mm (30-025166-10) BT230 (Fibre), 1.80mm, 1 Notch BT240 (Fibre), 1.95mm, 2 Notches (30-025168-10)	DV680▲ (21-25142-26/0)	EV684 (22-25142-00/0) GV680▲ [100]
149 B3.000	1697	4	82.60	SOHC		42/57			
146 B2.000	1697	4	82.60			46/63			
Uno 1.9L D Diesel					09/89 → 03/94	386	BT220 (Fibre), 1.65mm (30-025166-10) BT230 (Fibre), 1.80mm, 1 Notch BT240 (Fibre), 1.95mm, 2 Notches (30-025168-10)	DT290▲ (21-25950-21/0)	
149 B5.046	1929	4	82.60	Indirect Injection, SOHC		44/60			

HBS051 (22-17001B) M10x1.25x98mm (x5) M10x1.25x84mm (x5)		JM663 (31-024732-00) JN805 [156] (31-026819-00)	JH494 (31-022554-00) JJ453				BT220, BT230, BT240 	JJ398
HBS095 (22-17007B) M12x1.25x133mm (x10)	JC738 (31-026290-10)	JN459 (31-025142-10)	JJ298 (Cork) (Rubber) JJ398 (31-027379-00)	HR596	NA5187 30x52x7mm, ACM (50-319492-00) NB742 30x43x8mm, ACM (50-319408-00) NB732 74x90x10mm, FPM NA5062 74x90x10mm, ACM	KA556 [13] LT021 [13] [164] LT023 [13] LV583 [53] KT465 [54] LT019 [86] KT639 [11] LV589 [11] LT498 [45] LV582 [45] LV585 [45]	JC738 JM663 JN459 JN805 JH494 	JJ453
HBS095 (22-17007B) M12x1.25x133mm (x10)				HR596	NA5187 30x52x7mm, ACM (50-319492-00) NB742 30x43x8mm, ACM (50-319408-00) NB732 74x90x10mm, FPM		 JJ298	

		CC			9			CC			9
125E, 3020E	Petrol	1558	4	82.55	36	BRD	Petrol	2935	6	93.00	182
125E, 3020E	Petrol	1558	4	82.55	6	BRE	Petrol	2935	6	93.00	182
1Z	Diesel	1896	4	79.50	105	BRF	Petrol	2935	6	93.00	182
4AA	Diesel	2358	4	93.67	217	BRG	Petrol	2935	6	93.00	182
4AB	Diesel	2496	4	93.67	220	BRT	Petrol	2935	6	93.00	227
4AB	Diesel	2496	4	93.67	221	BTB	Diesel	1896	4	79.50	104
4AB	Diesel	2496	4	93.67	222	C9DA	Diesel	1753	4	82.50	92
4AB	Diesel	2496	4	93.67	223	C9DB	Diesel	1753	4	82.50	92
4BA	Diesel	2496	4	93.67	222	C9DC	Diesel	1753	4	82.50	92
4BC	Diesel	2496	4	93.67	224	CDB, CDC	Petrol	1599	4	82.00	119
4CA	Diesel	2496	4	93.67	222	CFBA	Petrol	1798	4	83.00	130
4CC	Diesel	2496	4	93.67	224	CGBA	Petrol	1796	4	83.00	127
4DA	Diesel	2496	4	93.67	225	CGBB	Petrol	1796	4	83.00	127
4EA	Diesel	2496	4	93.67	226	CJBA	Petrol	1999	4	87.50	132
4EB	Diesel	2496	4	93.67	226	CJBB	Petrol	1999	4	87.50	132
4EC	Diesel	2496	4	93.67	226	D18T	Diesel	1753	4	82.50	81
4ED	Diesel	2496	4	93.67	226	D2FA	Diesel	2402	4	89.90	218
4FA	Diesel	2496	4	93.67	224	D2FB	Diesel	2402	4	89.90	218
4FB	Diesel	2496	4	93.67	224	D3FA	Diesel	1998	4	86.00	213
4FC	Diesel	2496	4	93.67	224	D4FA	Diesel	2402	4	89.90	218
4FD	Diesel	2496	4	93.67	224	D5BA	Diesel	1998	4	86.00	133
4GA	Diesel	2496	4	93.67	226	D6BA	Diesel	1998	4	86.00	133
4GB	Diesel	2496	4	93.67	226	DHA	Petrol	1242	4	71.90	56
4GC	Diesel	2496	4	93.67	226	DHB	Petrol	1242	4	71.90	56
4GD	Diesel	2496	4	93.67	226	DHC	Petrol	1242	4	71.90	56
4GE	Diesel	2496	4	93.67	226	DHD	Petrol	1242	4	71.90	56
4GF	Diesel	2496	4	93.67	226	DHE	Petrol	1242	4	71.90	56
4HA	Diesel	2496	4	93.67	226	DHF	Petrol	1242	4	71.90	56
4HB	Diesel	2496	4	93.67	225	DHG	Petrol	1242	4	71.90	56
4HC	Diesel	2496	4	93.67	225	DOFA	Diesel	2402	4	89.90	219
4HD	Diesel	2496	4	93.67	226	E5FA	Petrol	2295	4	89.60	216
4RB	Petrol	1593	4	87.65	205	E5FC	Petrol	2295	4	89.60	216
4RC	Petrol	1993	4	90.80	207	E5SA	Petrol	2295	4	89.60	109
A9A, A9B	Petrol	1299	4	74.00	118	E5SB	Petrol	2295	4	89.60	109
A9JA	Petrol	1299	4	74.00	59	EDBA	Petrol	1988	4	84.80	7
A9JB	Petrol	1299	4	74.00	59	EDBB	Petrol	1988	4	84.80	7
AAA	Petrol	2792	6	81.00	110	EDBC	Petrol	1988	4	84.80	7
ABFA	Diesel	1998	4	86.00	213	EDBD	Petrol	1988	4	84.80	7
AFN	Diesel	1896	4	79.50	106	EDDB	Petrol	1988	4	84.80	96
AHU	Diesel	1896	4	79.50	105	EDDC	Petrol	1988	4	84.80	96
AJ	Petrol	2967	6	89.00	124	EDDD	Petrol	1988	4	84.80	96
AJ	Petrol	2967	6	89.00	125	EDDF	Petrol	1988	4	84.80	96
ALDA	Petrol	1988	4	84.80	98	EYDB	Petrol	1796	4	80.60	90
AMY	Petrol	2792	6	81.00	110	EYDC	Petrol	1796	4	80.60	90
ANU	Diesel	1896	4	79.50	105	EYDD	Petrol	1796	4	80.60	90
AODA	Petrol	1999	4	87.50	95	EYDE	Petrol	1796	4	80.60	90
AODB	Petrol	1999	4	87.50	95	EYDF	Petrol	1796	4	80.60	90
ARC	Petrol	2394	6	84.00	176	EYDG	Petrol	1796	4	80.60	90
ARD	Petrol	2394	6	84.00	176	EYDI	Petrol	1796	4	80.60	90
ASDA	Petrol	1388	4	76.00	84	EYDJ	Petrol	1796	4	80.60	90
ASDB	Petrol	1388	4	76.00	84	EYDL	Petrol	1796	4	80.60	90
ASZ	Diesel	1896	4	79.50	104	EYPA	Petrol	1796	4	80.60	203
AUY	Diesel	1896	4	79.50	104	EYPA	Petrol	1796	4	80.60	228
AVG	Diesel	1896	4	79.50	106	EYPC	Petrol	1796	4	80.60	203
AYL	Petrol	2792	6	81.00	111	F3FA	Diesel	1998	4	86.00	213
AZWA	Diesel	1997	4	85.00	107	F4A	Petrol	1392	4	77.24	63
AZWA	Diesel	1997	4	85.00	201	F4B	Petrol	1392	4	77.24	21
B4A	Petrol	2935	6	93.00	200	F4FA	Diesel	2402	4	89.90	218
B4B	Petrol	2935	6	93.00	200	F6A	Petrol	1393	4	77.25	61
B4C	Petrol	2935	6	93.00	200	F6B	Petrol	1392	4	77.24	145
BAA	Petrol	1299	4	74.00	117	F6B	Petrol	1392	4	77.24	20
BAJA	Petrol	1299	4	74.00	59	F6C	Petrol	1392	4	77.25	61
BHDA	Diesel	1753	4	82.50	92	F6D	Petrol	1392	4	77.24	145
BHDB	Diesel	1753	4	82.50	92	F6D	Petrol	1392	4	77.24	20
BHPA	Diesel	1753	4	82.50	204	F6E	Petrol	1392	4	77.24	61
BHPA	Diesel	1753	4	82.50	229	F6F	Petrol	1392	4	77.24	145
BOA	Petrol	2935	6	93.00	182	F6F	Petrol	1392	4	77.24	19
BOB	Petrol	2935	6	93.00	182	F6G	Petrol	1392	4	77.24	145
BRC	Petrol	2935	6	93.00	182	F6G	Petrol	1392	4	77.24	19

		CC			9			CC			9
F6JA / DV4TD	Diesel	1398	4	73.70	101	HCPB	Diesel	1753	4	82.50	204
F6JA / DV4TD	Diesel	1398	4	73.70	66	HHDA	Diesel	1560	4	75.00	88
F6JB	Diesel	1398	4	73.70	101	HHDB	Diesel	1560	4	75.00	88
F6JB	Diesel	1398	4	73.70	66	HHJA	Diesel	1560	4	75.00	103
F9DA	Diesel	1753	4	82.50	92	HHJA	Diesel	1560	4	75.00	76
F9DB	Diesel	1753	4	82.50	92	HHJA, HHJB	Diesel	1560	4	75.00	88
FFDA	Diesel	1753	4	82.50	92	HHJB	Diesel	1560	4	75.00	103
FHA	Petrol	1388	4	76.00	65	HHJB	Diesel	1560	4	75.00	76
FHD	Petrol	1388	4	76.00	163	HJBA	Diesel	1998	4	86.00	133
FHE	Petrol	1388	4	76.00	65	HJBB	Diesel	1998	4	86.00	133
FHF	Petrol	1388	4	76.00	163	HJBC	Diesel	1998	4	86.00	133
FIFA	Diesel	1998	4	86.00	214	HL14G	Petrol	1392	4	77.25	145
FMBA, N7BA	Diesel	1998	4	86.00	133	HL16i	Petrol	1597	4	79.96	35
FUA	Petrol	1392	4	77.24	145	HMDA	Petrol	1988	4	84.80	97
FUA	Petrol	1392	4	77.24	20	HUWA	Petrol	2521	5	83.00	202
FUAA	Petrol	1392	4	77.24	20	HWDA	Petrol	1596	4	79.00	86
FUAA	Petrol	1392	4	77.25	20	HWDB	Petrol	1596	4	79.00	86
FUB	Petrol	1392	4	77.25	62	HXDA	Petrol	1596	4	79.00	89
FUC	Petrol	1392	4	77.24	145	HYDA	Petrol	2522	5	83.00	99
FUC	Petrol	1392	4	77.24	20	J1E	Petrol	1298	4	80.98	1
FUD	Petrol	1392	4	77.25	62	J4B / BL13	Petrol	1297	4	73.96	13
FUG	Petrol	1392	4	77.24	62	J4B / BL13	Petrol	1297	4	73.96	142
FUH	Petrol	1392	4	77.24	146	J4B / BL13	Petrol	1297	4	73.96	15
FUH	Petrol	1392	4	77.24	21	J4C/Endura E	Petrol	1297	4	73.96	60
FUJ	Petrol	1392	4	77.24	62	J4D/Endura E	Petrol	1299	4	74.00	117
FUJA	Petrol	1242	4	71.90	55	J4J	Petrol	1299	4	74.00	60
FUJA	Petrol	1242	4	71.90	83	J4K	Petrol	1299	4	74.00	117
FUJB	Petrol	1242	4	71.90	55	J4L	Petrol	1299	4	74.00	60
FUJB	Petrol	1242	4	71.90	83	J4M	Petrol	1299	4	74.00	117
FXDA	Petrol	1388	4	76.00	85	J4N	Petrol	1299	4	74.00	117
FXDB	Petrol	1388	4	76.00	85	J4P	Petrol	1299	4	74.00	117
FXDC	Petrol	1388	4	76.00	85	J4Q	Petrol	1299	4	74.00	60
FXDD	Petrol	1388	4	76.00	85	J4R	Petrol	1299	4	74.00	60
FXFA	Diesel	2402	4	89.90	219	J4S	Petrol	1299	4	74.00	117
FXJA	Petrol	1388	4	76.00	100	J4T	Petrol	1299	4	74.00	60
FXJA	Petrol	1388	4	76.00	64	J6A	Petrol	1297	4	73.96	13
FXJB	Petrol	1388	4	76.00	100	J6A	Petrol	1297	4	73.96	142
FXJB	Petrol	1388	4	76.00	64	J6A	Petrol	1297	4	73.96	15
FYDA	Petrol	1596	4	79.00	87	J6B	Petrol	1297	4	73.96	58
FYDB	Petrol	1596	4	79.00	87	JBA	Petrol	1297	4	73.96	18
FYDC	Petrol	1596	4	79.00	87	JBB	Petrol	1297	4	73.94	14
FYDD	Petrol	1596	4	79.00	87	JBB	Petrol	1297	4	73.94	144
FYDH	Petrol	1596	4	79.00	87	JBC	Petrol	1297	4	73.96	58
FYJA	Petrol	1596	4	79.00	102	JBD	Petrol	1297	4	73.96	13
FYJA	Petrol	1596	4	79.00	74	JCT	Petrol	1294	4	79.00	183
FYJB	Petrol	1597	4	76.00	102	JJA	Petrol	1297	4	73.96	60
FYJB	Petrol	1597	4	76.00	74	JJB/Endura E	Petrol	1299	4	74.00	117
G6A	Petrol	1118	4	68.70	53	JJC	Petrol	1299	4	74.00	60
G6DA	Diesel	1997	4	85.00	94	JJD	Petrol	1297	4	73.96	117
G6DB	Diesel	1997	4	85.00	94	JJE/Endura E	Petrol	1299	4	74.00	60
G6DD	Diesel	1997	4	85.00	94	JJF	Petrol	1299	4	74.00	117
G8DA	Diesel	1560	4	75.00	88	JJG	Petrol	1299	4	74.00	117
G8DA, G8DB	Diesel	1560	4	75.00	88	JJH	Petrol	1299	4	74.00	117
G8DB	Diesel	1560	4	75.00	88	JJJ	Petrol	1299	4	74.00	60
GLB	Petrol	1118	4	73.94	11	JJK	Petrol	1299	4	74.00	60
GLC	Petrol	1118	4	73.94	52	JJL	Petrol	1299	4	74.00	117
GLW	Petrol	1118	4	73.94	52	JJM	Petrol	1299	4	74.00	60
GPA	Petrol	1118	4	73.94	11	JLA	Petrol	1297	4	73.94	14
GSE	Petrol	1118	4	73.94	11	JLA	Petrol	1297	4	73.94	144
GSF	Petrol	1118	4	73.94	52	JLA	Petrol	1297	4	73.94	17
GSG	Petrol	1117	4	73.94	12	JLB	Petrol	1297	4	73.94	14
GSH	Petrol	1118	4	73.94	52	JLB	Petrol	1297	4	73.94	144
GUD	Petrol	1118	4	68.70	53	JPA	Petrol	1296	4	79.96	143
GUE	Petrol	1118	4	68.70	53	JPA	Petrol	1296	4	79.96	16
GZ	Petrol	2261	4	87.50	121	JPC	Petrol	1296	4	79.96	57
GZFA	Petrol	2295	4		215	KA-24	Petrol	2389	4	89.00	122
H9FA	Diesel	2402	4	89.90	219	KA24-E	Petrol	2389	4	89.00	122
HCPA	Diesel	1753	4	82.50	204	KKDA	Diesel	1753	4	82.50	93
HCPA, HCPB	Diesel	1753	4	82.50	229	KL16H (711M)	Petrol	1599	4	80.98	33

			CC			9				CC			9
L1E	Petrol	1597	4	76.00	155		LUK	Petrol	1597	4	79.96	153	
L1E	Petrol	1597	4	76.00	25		LUK	Petrol	1597	4	79.96	24	
L1E	Petrol	1597	4	76.00	29		M7JA	Petrol	1242	4	71.90	54	
L1F	Petrol	1597	4	76.00	126		M7JB	Petrol	1242	4	71.90	54	
L1G	Petrol	1597	4	76.00	72		MEBA	Petrol	2967	6	89.00	141	
L1H	Petrol	1597	4	76.00	25		MHA	Petrol	1679	4	80.00	165	
L1H	Petrol	1597	4	76.00	29		MHB	Petrol	1679	4	80.00	165	
L1J	Petrol	1597	4	76.00	126		N3A	Petrol	1998	4	86.00	173	
L1K	Petrol	1597	4	76.00	155		N4A	Petrol	1993	4	90.80	191	
L1K	Petrol	1597	4	76.00	25		N4B	Petrol	1993	4	90.80	191	
L1K	Petrol	1597	4	76.00	29		N4I	Petrol	1993	4	90.80	191	
L1L	Petrol	1597	4	76.00	126		N4JB	Petrol	1999	4	87.50	82	
L1N	Petrol	1597	4	76.00	126		N5B	Petrol	1993	4	90.83	195	
L1Q	Petrol	1597	4	76.00	126		N5F	Petrol	1994	4	90.83	48	
L1T	Petrol	1596	4	79.00	73		N6T	Petrol	1993	4	90.80	209	
L1V	Petrol	1596	4	79.00	73		N7A	Petrol	1998	4	86.00	47	
L1W	Petrol	1596	4	79.00	164		N8A	Petrol	1998	4	86.00	168	
L4B	Petrol	1598	4	79.96	151		N8A	Petrol	1998	4	86.00	189	
L4B	Petrol	1598	4	79.96	27		N8A	Petrol	1998	4	86.00	194	
L6B	Petrol	1597	4	79.96	185		N8B	Petrol	1984	4	86.00	174	
LAT	Petrol	1594	4	87.65	206		N8C	Petrol	1998	4	86.00	193	
LAT	Petrol	1594	4	87.65	34		N8D	Petrol	1993	4	90.80	169	
LCBA	Petrol	2544	6	82.40	9		N9B	Petrol	1998	4	86.00	170	
LCBB	Petrol	2495	6	81.60	8		N9B	Petrol	1998	4	86.00	194	
LCBC	Petrol	2495	6	81.60	8		N9C	Petrol	1998	4	86.00	194	
LCBD	Petrol	2495	6	81.60	140		N9D	Petrol	1998	4	86.00	170	
LCBE	Petrol	2495	6	81.60	8		N9E	Petrol	1998	4	86.00	189	
LCK	Petrol	1593	4	87.65	112		N9E	Petrol	1998	4	86.00	190	
LCN	Petrol	1593	4	87.65	2		N9F	Petrol	1998	4	86.00	170	
LCR	Petrol	1594	4	87.65	34		NAE	Petrol	1993	4	90.80	162	
LCS	Petrol	1593	4	87.65	184		NAT	Petrol	1993	4	90.80	208	
LCT	Petrol	1593	4	87.65	184		NAV	Petrol	1993	4	90.80	208	
LHA	Petrol	1597	4	79.96	71		NBA	Petrol	1993	4	90.80	211	
LJB	Petrol	1597	4	79.96	152		NCA	Petrol	1994	4	90.80	211	
LJB	Petrol	1597	4	79.96	28		NE	Petrol	1993	4	90.80	46	
LJC	Petrol	1597	4	80.00	69		NES	Petrol	1993	4	90.80	191	
LJD	Petrol	1597	4	79.96	68		NEJ	Petrol	1993	4	90.80	191	
LJF	Petrol	1597	4	79.96	154		NEK	Petrol	1993	4	90.80	113	
LJF	Petrol	1597	4	79.96	22		NEL	Petrol	1993	4	90.80	169	
LNA	Petrol	1597	4	79.96	30		NEN	Petrol	1993	4	90.80	3	
LNB	Petrol	1597	4	79.96	31		NEN	Petrol	1993	4	90.80	46	
LP1	Petrol	1597	4	79.96	147		NEP	Petrol	1993	4	90.80	113	
LP1	Petrol	1597	4	79.96	23		NES	Petrol	1993	4	90.80	193	
LP2	Petrol	1597	4	79.96	24		NET	Petrol	1993	4	90.80	192	
LPA	Petrol	1597	4	79.96	147		NGA	Petrol	1988	4	84.80	134	
LPA	Petrol	1597	4	79.96	23		NGA	Petrol	1988	4	84.80	135	
LR1	Petrol	1597	4	79.96	148		NGB	Petrol	1988	4	84.80	134	
LR1	Petrol	1597	4	79.96	32		NGC	Petrol	1988	4	84.80	134	
LR2	Petrol	1597	4	79.96	27		NGD	Petrol	1988	4	84.80	134	
LRA	Petrol	1597	4	79.96	148		NR2	Petrol	1993	4	90.80	191	
LRA	Petrol	1597	4	79.96	32		NRA	Petrol	1993	4	90.80	172	
LRB	Petrol	1597	4	79.96	150		NRB	Petrol	1993	4	90.80	191	
LRB	Petrol	1597	4	79.96	27		NRC	Petrol	1995	4	90.83	172	
LRB	Petrol	1597	4	79.96	28		NRD	Petrol	1993	4	90.80	191	
LSD	Petrol	1593	4	81.30	184		NRI	Petrol	1993	4	90.80	172	
LSE	Petrol	1593	4	81.30	184		NSD	Petrol	1998	4	86.00	171	
LSF	Petrol	1597	4	81.30	184		NSE	Petrol	1998	4	86.00	108	
LTA	Diesel	1608	4	80.00	156		NSF	Petrol	1998	4	86.00	210	
LTA	Diesel	1608	4	80.00	26		NSG	Petrol	1998	4	86.00	210	
LTB	Diesel	1608	4	80.00	75		NSH	Bi-Fuel	1998	4	86.00	212	
LTC	Diesel	1608	4	80.00	156		NYP	Petrol	1996	6	93.64	114	
LTC	Diesel	1608	4	80.00	26		PR5	Petrol	2792	6	93.00	199	
LUB	Petrol	1597	4	79.96	67		PR6	Petrol	2792	6	93.00	199	
LUC	Petrol	1597	4	79.96	149		PR7	Petrol	2792	6	93.00	198	
LUD	Petrol	1597	4	79.96	67		PR8	Petrol	2792	6	93.00	198	
LUG	Petrol	1597	4	79.96	24		PRE	Petrol	2792	6	93.00	181	
LUH	Petrol	1597	4	76.00	70		PRG	Petrol	2792	6	93.00	198	
LUJ	Petrol	1597	4	79.96	153		PRN	Petrol	2792	6	93.00	5	
LUJ	Petrol	1597	4	79.96	24		PRT	Petrol	2792	6	93.00	199	

			CC			9			CC			9
PYN	Petrol		2792	6	93.00	4	RTJ	Diesel	1753	4	82.50	79
Q7DA	Petrol		1798	4	83.00	91	RTK	Diesel	1753	4	82.50	79
Q7DA	Flexfuel		1798	4	83.00	91	RTN	Diesel	1753	4	82.50	80
QJBA	Diesel		2198	4	86.00	136	RTP	Diesel	1753	4	82.50	80
QJBB	Diesel		2198	4	86.00	136	RTQ	Diesel	1753	4	82.50	80
QQDA	Petrol		1798	4	83.00	91	RVA	Diesel	1753	4	82.50	45
QQDB	Petrol		1798	4	83.00	91	SCB	Diesel	2500	4	92.00	180
QXWA	Diesel		1997	4	85.00	107	SCC	Diesel	2500	4	92.00	180
QXWA	Diesel		1997	4	85.00	201	SDBA	Diesel	1998	4	86.00	133
QXWB	Diesel		1997	4	85.00	107	SEA	Petrol	2544	6	81.60	139
QXWB	Diesel		1997	4	85.00	201	SEB	Petrol	2495	6	81.60	138
R2A	Petrol		1796	4	86.20	186	SEC	Petrol	2495	6	81.60	138
R2C	Petrol		1769	4	79.94	187	SFA (XD3T)	Diesel	2498	4	94.00	179
R6A	Petrol		1769	4	79.94	187	SFB (XD3T)	Diesel	2498	4	94.00	179
RDA	Petrol		1796	4	80.60	157	SGA	Petrol	2495	6	81.60	138
RDA	Petrol		1796	4	80.60	37	SGA	Petrol	2495	6	81.60	8
RDA	Petrol		1796	4	80.60	38	SHDA	Petrol	1596	4		86
RDB	Petrol		1796	4	80.60	77	STP (XD3/XD3P)	Diesel	2498	4	94.00	115
REB	Petrol		1796	4	86.20	186	STR (XD3/XD3P)	Diesel	2498	4	94.00	177
REBA	Petrol		2967	6	89.00	141	STR (XD3/XD3P)	Diesel	2498	4	94.00	178
REC	Petrol		1796	4	86.20	167	TD27	Diesel	2664	4	96.00	123
RED	Petrol		1796	4	86.20	186	TD27E	Diesel	2664	4	96.00	123
REF	Petrol		1796	4	86.20	186	TKB	Petrol	957	4	73.94	49
RFA	Diesel		1753	4	82.50	161	TL 20 H	Petrol	1993	4	90.80	3
RFA	Diesel		1753	4	82.50	188	TLB	Petrol	999	4	68.70	50
RFB	Diesel		1753	4	82.50	188	UC	Petrol	1416	4	77.00	10
RFD	Diesel		1753	4	82.50	160	VM	Diesel	2500	4	92.00	180
RFD	Diesel		1753	4	82.50	43	WL	Diesel	2500	4	93.00	166
RFD	Diesel		1753	4	82.50	45	WL-T	Diesel	2500	4	93.00	166
RFK	Diesel		1753	4	82.50	160	Y5A	Petrol	2295	4	89.60	175
RFK	Diesel		1753	4	82.50	43	Y5B	Petrol	2295	4	89.60	109
RFK	Diesel		1753	4	82.50	45	YF	Petrol	1988	4	84.80	120
RFL	Diesel		1753	4	82.50	188	YTR (XD2/XD2P/XD94)	Diesel	2304	4	94.00	197
RFM	Diesel		1753	4	82.50	131	YTT (XD2/XD2P/XD94)	Diesel	2304	4	94.00	197
RFN	Diesel		1753	4	82.50	131	YYT	Petrol	2293	6	90.00	196
RFS	Diesel		1753	4	82.50	43	ZVSA	Petrol	1998	4	86.00	108
RKA	Petrol		1796	4	80.60	129						
RKB	Petrol		1796	4	80.60	128						
RKB	Petrol		1796	4	80.60	129						
RKC	Petrol		1796	4	80.60	38						
RKF	Petrol		1796	4	80.60	128						
RKH	Petrol		1796	4	80.60	128						
RKJ	Petrol		1796	4	80.60	128						
RKK	Petrol		1796	4	80.60	128						
RQB	Petrol		1796	4	80.60	157						
RQB	Petrol		1796	4	80.60	37						
RQB	Petrol		1796	4	80.60	38						
RQC	Petrol		1796	4	80.60	77						
RTA	Diesel		1753	4	82.50	158						
RTA	Diesel		1753	4	82.50	39						
RTB	Diesel		1753	4	82.50	158						
RTB	Diesel		1753	4	82.50	39						
RTC	Diesel		1753	4	82.50	78						
RTD	Diesel		1753	4	82.50	78						
RTE	Diesel		1753	4	82.50	159						
RTE	Diesel		1753	4	82.50	40						
RTE	Diesel		1753	4	82.50	42						
RTE	Diesel		1753	4	82.50	44						
RTE, RTE, RTH	Diesel		1753	4	82.50	44						
RTF	Diesel		1753	4	82.50	159						
RTF	Diesel		1753	4	82.50	40						
RTF	Diesel		1753	4	82.50	42						
RTF	Diesel		1753	4	82.50	44						
RTG	Diesel		1753	4	82.50	78						
RTH	Diesel		1753	4	82.50	159						
RTH	Diesel		1753	4	82.50	40						
RTH	Diesel		1753	4	82.50	41						
RTH	Diesel		1753	4	82.50	42						
RTH	Diesel		1753	4	82.50	44						







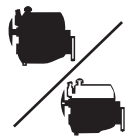



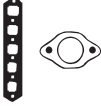

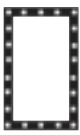

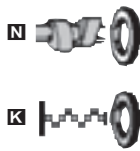





































FORD



KW/PS



Capri 1.3L						01/78 → 06/85	1	BJ200 (Fibre)	DJ202	EH750
JTE	1298	4	80.98	OHV		40/54				
Capri 1.6L						01/78 → 04/87	2	AH850 (Fibre) (30-022666-20)	CH851 (21-22641-20/0) → 08/83 CH854 09/83 →	EH850 (22-22677-00/0)
LCN	1593	4	87.65	SOHC		54/73				
Capri 2.0L						01/78 → 12/85	3	AH860 (Fibre) (30-025148-10)	CH861 → 08/83 CH864 (21-25148-40/0) 09/83 →	EH850 (22-22677-00/0)
TL 20 H	1993	4	90.80	Carburettor, SOHC		72-74/ 98-101				
NEN	1993	4	90.80	Carburettor, SOHC		73/100				
Capri 2.8L i Turbo						01/82 → 04/87	4	BL400 (Fibre)	DL401	
PYN	2792	6	93.00	V6		138/188		BL410 (Fibre)		
Capri 2.8L Super Injection						01/81 → 04/87	5	BL400 (Fibre)	DL401	
PRN	2792	6	93.00	Injection, OHV, V6		118/160		BL410 (Fibre)		
Cortina Coupe Lotus						10/62 → 09/70	6	AF880 (Fibre)	CF880	EH761
125E, 3020E	1558	4	82.55			78/106				
Cougar 2.0L 16V						08/98 → 12/01	7	BZ490 (MLS) (30-027876-10) → 01/99 AE5320 (MLS) (30-029870-00) 02/99 →		EW630 (22-28450-00/0) → 12/98 EC5800 (22-29400-00/0) 12/98 →
EDBA/EDBB/EDBC/EDBD	1988	4	84.80	DOHC		96/100/ 131/ 136				
Cougar 2.5L V6 24V						06/00 → 12/01	8	AC5790 (MLS)		
LCBB/LCBC/LCBE	2495	6	81.60	Injection, DOHC, V6		107/148		AC5780 (MLS)		
SGA	2495	6	81.60	Injection, DOHC, V6		151/205		(30-029588-00)		
Cougar 2.5L V6 24V						08/98 → 12/01	9	AC5880 (MLS)		
LCBA	2544	6	82.40	V6		125/170		AC5870 (MLS)		
								AC5790 (MLS)		
								AC5780 (MLS)		
								(30-029588-00)		
								10/00 →		
Econovan 1.4L						03/86 → 03/92	10	BE540 (Graphite)	DE545	GE541
UC	1416	4	77.00	Carburettor		48/65				







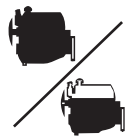



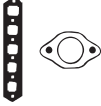

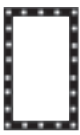

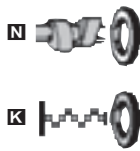

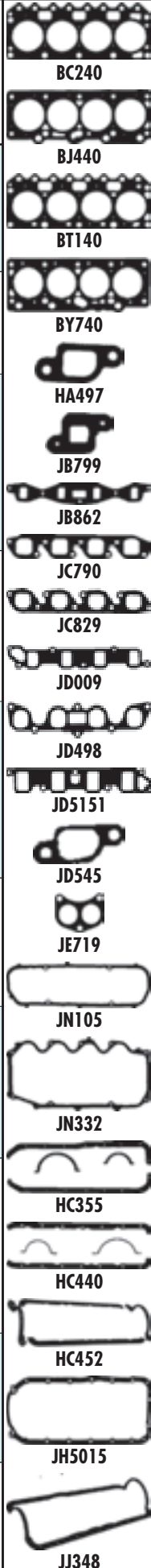





































































































								
		JA613 ■ (31-022298-10) JB811 ■ (31-022293-10) JB812 ■ (x2)	JM478 (31-022174-00)	HC070 ■	HR632 ■ (50-022354-10)	NA576 ■ 36.5x52.3x8mm, MVQ (50-306573-00) NA793 ■ 79x95.3x11.1mm, MVQ	NA579 [2] ■ NA580 [2] ■ JR265 [11]	 AC5780  AC5790  AC5870  AC5880  AE5320  AF880  AH850, AH860  BE540  BJ200  BL400  BL410  BZ490  JA086  JA475  JA613  JA768  JA769  JA770  JB811  JB812 JC364
HBS056 ⊕ (22-18002B) M12x1.75x92.5mm (x10)	JA769 ■ (31-022642-10) JA768 ■ (31-022672-10) JA770 ■ (x3) (31-022671-10)	JM510 (31-022641-20) →08/83 JN620 (31-024963-40) 09/83 →	HC285 ■ (23-22677-00/0)	HR631 ■ (24-30612-25/0) HR661 ■ [1] (50-306802-50)	NA5190 ■ (x2) 42x56x7mm, FPM (50-307352-70) NA5190 ■ 42x56x7mm, FPM (50-307352-70) NA793 ■ 79x95.3x11.1mm, MVQ NB788 ■ 79.4x95.3x11.1mm, PTFE (50-306413-50)	NA580 [2] ■ NA585 [2] ■ KA289 [13]	 AC5870  AC5880  JM460  JM478  JM510  JM5154	
HBS056 ⊕ (22-18002B) M12x1.75x92.5mm (x10)	JA769 ■ (31-022642-10) JA768 ■ (31-022672-10) JA770 ■ (x3) (31-022671-10) ⊕ JE719	JM510 (31-022641-20) →08/83 JN620 (31-024963-40) 08/83 →	HC285 ■ (23-22677-00/0)		NA5190 ■ (x2) 42x56x7mm, FPM (50-307352-70) NA5190 ■ 42x56x7mm, FPM (50-307352-70) NA793 ■ 79x95.3x11.1mm, MVQ NB788 ■ 79.4x95.3x11.1mm, PTFE (50-306413-50)		 JM460  JM478  JM510  JM5154	
	JC364 ■ (31-024452-10) JC365 ■ (x4) (32-206600-10)	JM875 (x2) (31-021055-10)	HC418 ■ (23-21053-01/0)	HR633 ■ ■ (50-022425-10) HR630 ■ ■	NA5190 ■ 42x56x7mm, FPM (50-307352-70) NB564 ■ 60.5x76.2x10mm, FPM (50-307219-70)	NA580 [2] ■ NA585 [2] ■	 JM5154  JM875	
	JC364 ■ (31-024452-10) JC365 ■ (x6) (32-206600-10)	JM875 (x2) (31-021055-10)	HC418 ■ (23-21053-01/0) →08/85 JJ458 (50-025667-00) 09/85 →	HR633 ■ ■ (50-022425-10) HR630 ■ ■	NA5190 ■ 42x56x7mm, FPM (50-307352-70) NB564 ■ 60.5x76.2x10mm, FPM (50-307219-70)	NA580 [2] ■ NA585 [2] ■	 JM875  JM620	
	JA475 ■ (x4)	JM460	HC060 ■		NA576 ■ 36.5x52.3x8mm, MVQ (50-306573-00) NA793 ■ 79x95.3x11.1mm, MVQ	NA580 [2] ■	 JM620  HC070	
HBS031 ⊕ (22-18008B) M10x1.50x102mm (x10)	JD5311 ■ (x4) (50-029872-00) →08/99 JD5312 ■ (x4) (50-029873-00) 09/98 → JE5021 ■ (31-028435-00)	JM5154 (50-029581-00) →04/99 JM5184 (50-029871-00) Light Blue 05/99 →	JH5061 (50-029586-00)	HR5033 ■ (24-30715-70/0)	NB958 ■ (x2) 42x53x7mm, FPM (50-319323-00) NB959 ■ 35x50x7mm, FPM (50-306644-50) NB847 ■ 88x108x11mm, FPM (50-307171-70)		 JM5154  JM5184  JM5061	
HBS392 ⊕ [251] (22-18096B)					NA5175 ■ 91x108x9.5mm, NBR (50-319459-00)		 JM5061  JM5065	
			JH5065 (31-029698-00)		NA5175 ■ 91x108x9.5mm, NBR (50-319459-00)		 JM5065  JJ458	
HBS056 ⊕ (22-18002B) M12x1.75x92.5mm (x10)	JA086 ■	JM053	JH040	KJ710 (x8)	NB384 ■ 40x55x8mm, NBR		 JM053  JM053  JM053	



KW/PS



Escort 1.1L					09/80 → 02/86	11			EA440 (22-24480-00/0)
GLB	1118	4	73.94	CVH	37/50				
GSE	1118	4	73.94	Carburettor, CVH	37/50				
GPA	1118	4	73.94	CVH	43/58				
Escort 1.1L					10/85 → 09/90	12	BC240 (Fibre) (30-023756-20)	DC240 ■ (21-23756-21/0)	EG340 (22-23830-00/0)
GSG	1117	4	73.94	Carburettor, OHV	37/50				
GSG	1117	4	73.94	Carburettor, OHV	37/50				
Escort 1.3L					07/90 → 01/95	13	BT140 (Fibre) (30-026496-00)	DT140 (21-26496-20/0)	EH752
J4B / BL13/J6A	1297	4	73.96	CFi, HCS	44/60				
JBD	1297	4	73.96	CFi, HCS	46/63				
Escort 1.3L					01/86 → 07/90	14	BC240 (Fibre) (30-023756-20)	DC240 ■ (21-23756-21/0)	EH752 EY671 [5] (22-29632-00/0)
JBB	1297	4	73.94	Carburettor, HCS	44/60				
JLA/JLB	1297	4	73.94	Carburettor, OHV	44/60				
Escort 1.3L					01/95 → 02/99	15	BT140 (Fibre) (30-026496-00)	DY671 ■ (21-26496-21/0)	EY671 (22-29632-00/0)
J4B / BL13/J6A	1297	4	73.96	CFi, HCS	44/60				
Escort 1.3L					09/80 → 02/86	16	BJ440 (Fibre) (30-025123-20)	DJ440	EA440 (22-24480-00/0) →12/85
Escort Convertible 1.3L					09/83 → 12/85				
JPA	1296	4	79.96	Carburettor, CVH	51/69				
Escort 1.3L					11/86 → 07/88	17	BC240 (Fibre) (30-023756-20)	DC240 ■ (21-23756-21/0)	EH752
JLA	1297	4	73.94		44/60				
Escort 1.3L					07/88 → 10/90	18	BT140 (Fibre) (30-026496-00)	DT140 (21-26496-20/0)	EH752
JBA	1297	4	73.96	Carburettor, HCS	44/63				
Escort 1.4L					07/90 → 01/95	19	BY740 (Fibre) (30-025122-20)	DY740 (21-24964-20/0)	EA441 (22-25409-00/0)
Escort Convertible 1.4L					07/90 → 04/94				
F6F/F6G	1392	4	77.24	Injection, CVH	52/71				
Escort 1.4L					10/85 → 10/90	20	BY740 (Fibre) (30-025122-20)	DP790 (21-25122-21/0)	EA441 (22-25409-00/0)
Escort 1.4L i					02/86 → 07/90				
Escort Convertible 1.4L					01/86 → 07/90				
FUAA	1392	4	77.24	Injection, CVH	51/69				
F6B/F6D/FUA/FUC	1392	4	77.24	Injection, CVH	55/75				
FUAA	1392	4	77.25		51/69				











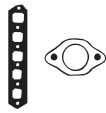

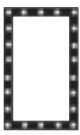

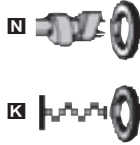









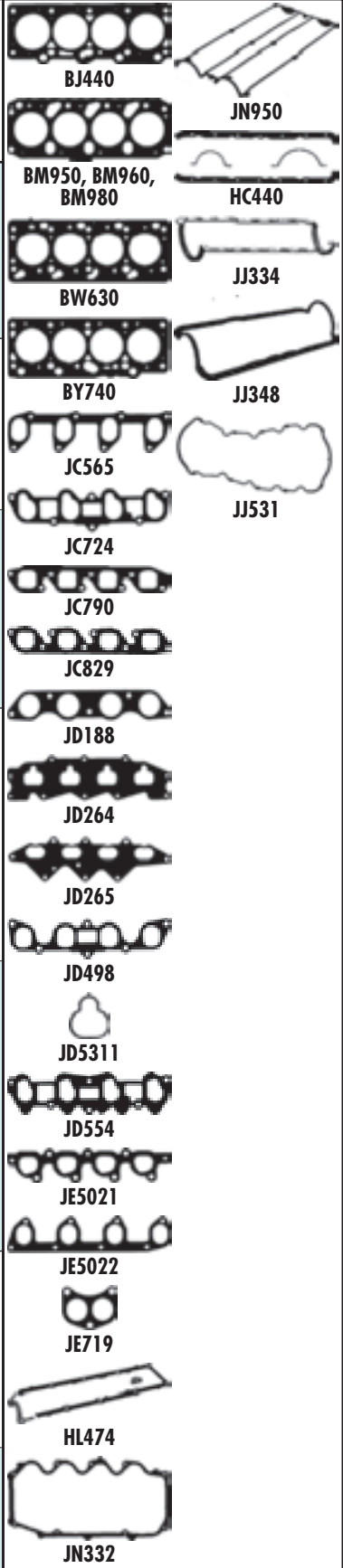







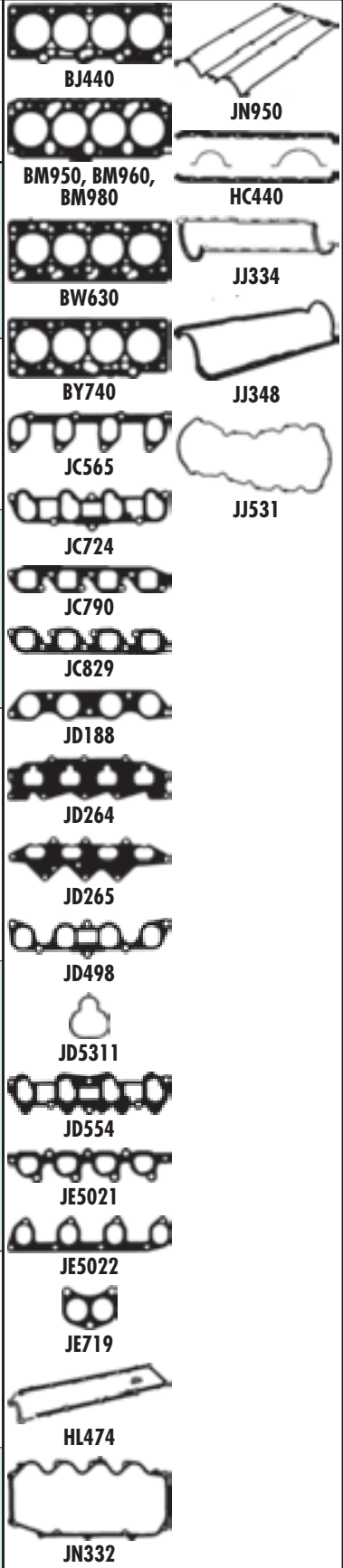













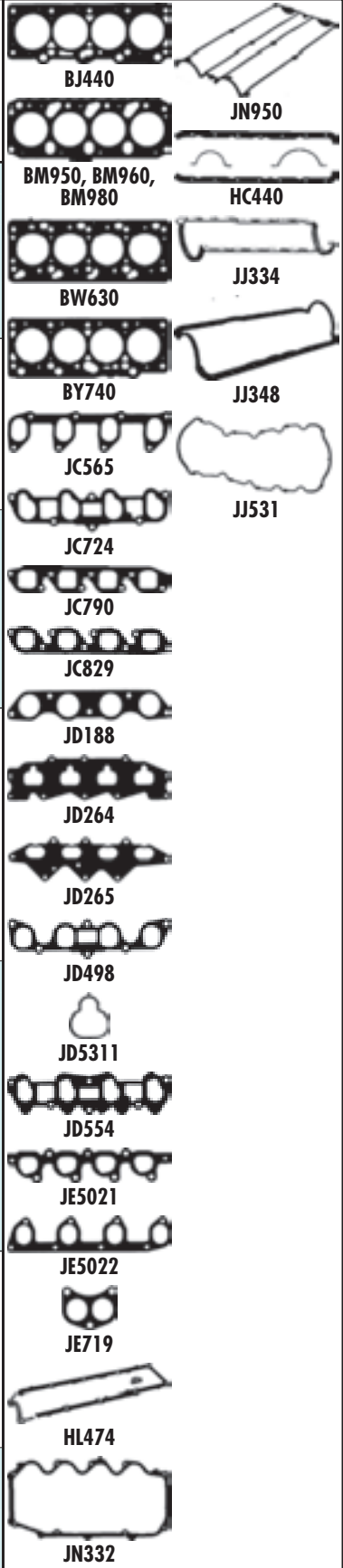











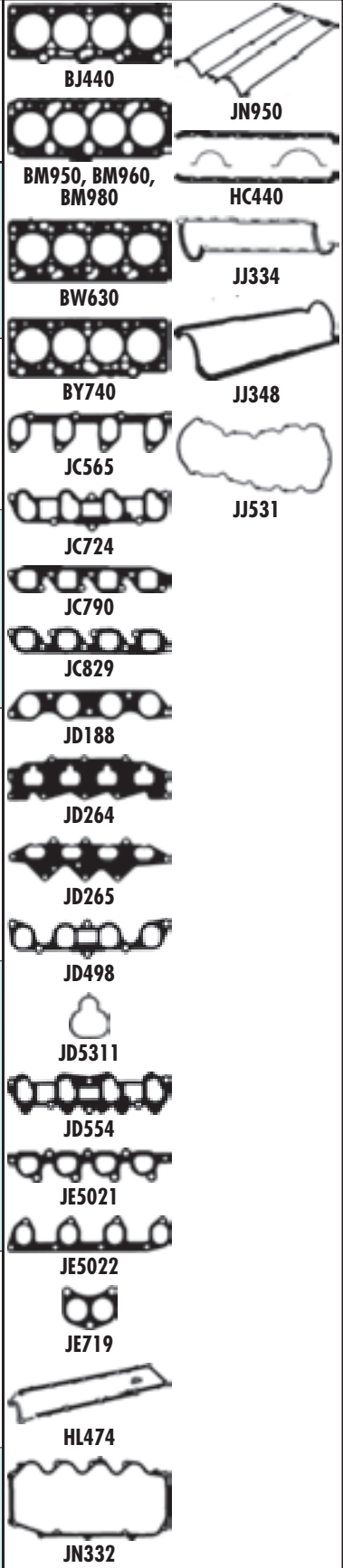









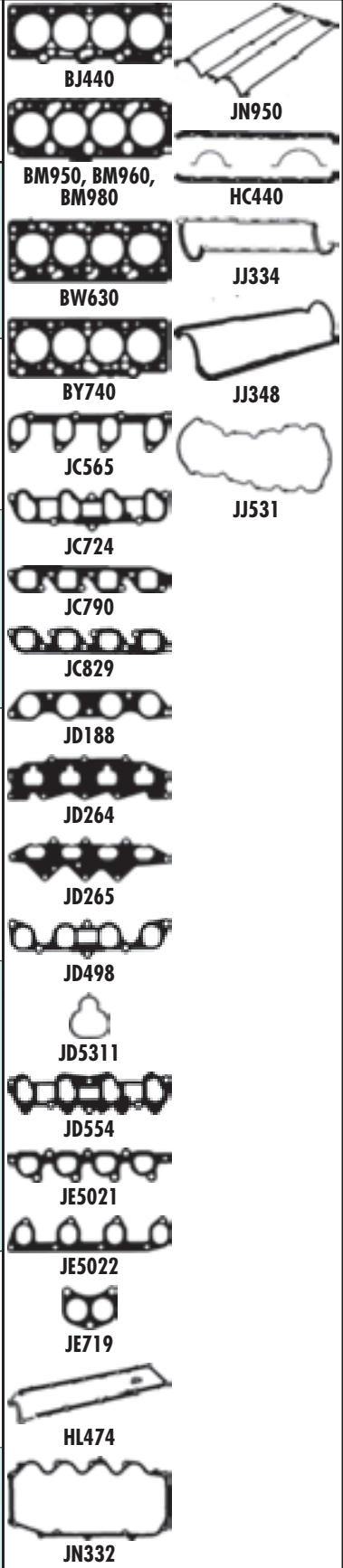











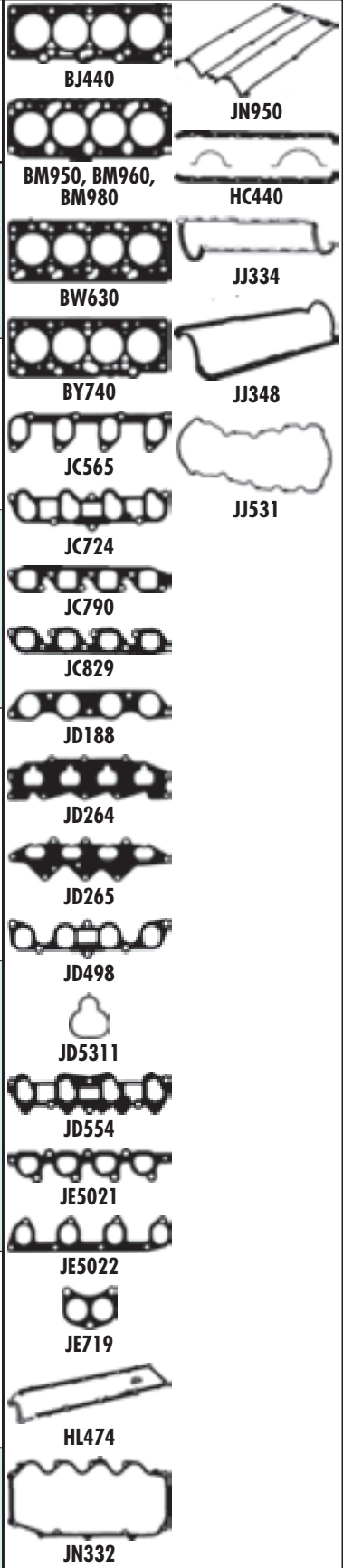



								
HBS001  (22-18083B) M10x1.50x135mm (x10)	JD498  (31-024472-10)	JN332 (31-024964-10)	HC440  (23-24480-00/0)	HR631  (24-30612-25/0) HR661  [1] (50-306802-50)	NA5190  42x56x7mm, FPM (50-307352-70) NB645  35x50x7mm, MVQ NB847  88x108x11mm, FPM (50-307171-70)	NA585 [2] 	BC240 BJ440 BT140	
HBS050  (22-18001B) M11x1.50x120mm (x10)	JB862  (31-023758-10) JB799  (x4) (31-023762-20)	JN105 (31-027902-00)	HC355  (23-23528-00/0)	HR631  (24-30612-25/0) HR661  [1] (50-306802-50)	NA576  36.5x52.3x8mm, MVQ (50-306573-00) NB564  60.5x76.2x10mm, FPM (50-307219-70)	NA585 [2] 	BY740	
HBS050  (22-18001B) M11x1.50x120mm (x10)	JD009  (31-026514-00) JD545  (x4) (31-029228-00) HA497 	JN105 (31-027902-00)	HC452  (23-23528-02/0)	HR655  24-30691-15/0	NB572  50x70x6mm, NBR NA576  36.5x52.3x8mm, MVQ (50-306573-00) NA793  79x95.3x11.1mm, MVQ NB788  79.4x95.3x11.1mm, PTFE (50-306413-50)	NB655 [2]  NA585 [2] 	HA497 JB799 JB862	
HBS050  (22-18001B) M11x1.50x120mm (x10)	JB862  (31-023758-10) JB799  (x4) (31-023762-20) 	JN105 (31-027902-00)	HC452  (23-23528-02/0)	HR631  (24-30612-25/0) HR661  [1] (50-306802-50)	NA576  36.5x52.3x8mm, MVQ (50-306573-00) NA793  79x95.3x11.1mm, MVQ NB788  79.4x95.3x11.1mm, PTFE (50-306413-50)	NB596 [2]  NB655 [2]  NA585 [2] 	JC790 JC829	
HBS050  (22-18001B) M11x1.50x120mm (x10)	JD5151  (31-029227-00) JD545  (x4) (31-029228-00) HA497 	JN105 (31-027902-00)	JH5015 (50-029632-00)	HR655  24-30691-15/0	NB572  50x70x6mm, NBR NA576  36.5x52.3x8mm, MVQ (50-306573-00) NA793  79x95.3x11.1mm, MVQ NB788  79.4x95.3x11.1mm, PTFE (50-306413-50)	NB655 [2]  NA585 [2] 	JD498 JD5151	
HBS001  (22-18083B) M10x1.50x135mm (x10)	JD498  (31-024472-10) JC829  (31-025656-10) 	JN332 (31-024964-10)	HC440  (23-24480-00/0)	HR631  (24-30612-25/0) HR661  [1] (50-306802-50)	NA5190  42x56x7mm, FPM (50-307352-70) NB645  35x50x7mm, MVQ NB847  88x108x11mm, FPM (50-307171-70)	NB596 [2]  NA585 [2] 	JD545 JE719	
HBS050  (22-18001B) M11x1.50x120mm (x10)	JB862  (31-023758-10) JB799  (x4) (31-023762-20) 	JN105 (31-027902-00)	HC452  (23-23528-02/0)	HR631  (24-30612-25/0) HR661  [1] (50-306802-50)	NA576  36.5x52.3x8mm, MVQ (50-306573-00) NA793  79x95.3x11.1mm, MVQ NB788  79.4x95.3x11.1mm, PTFE (50-306413-50)	NB596 [2]  NB655 [2]  NA585 [2] 	JN105	
HBS050  (22-18001B) M11x1.50x120mm (x10)	JD009  (31-026514-00) HA497 	JN105 (31-027902-00)	HC452  (23-23528-02/0)	HR655  24-30691-15/0	NB572  50x70x6mm, NBR NA576  36.5x52.3x8mm, MVQ (50-306573-00) NA793  79x95.3x11.1mm, MVQ NB788  79.4x95.3x11.1mm, PTFE (50-306413-50)	NB655 [2]  NA585 [2] 	HC355	
HBS001  (22-18083B) M10x1.50x135mm (x10)	JD498  (31-024472-10) JC790  (31-024473-20)	JN332 (31-024964-10)	JJ348 (50-025409-10)	HR631  (24-30612-25/0) HR661  [1] (50-306802-50)	NA5190  42x56x7mm, FPM (50-307352-70) NB645  35x50x7mm, MVQ NB847  88x108x11mm, FPM (50-307171-70)		HC452	
HBS001  (22-18083B) M10x1.50x135mm (x10)	JD498  (31-024472-10) JC790  (31-024473-20) 	JN332 (31-024964-10)	JJ348 (50-025409-10)	HR631  (24-30612-25/0) HR661  [1] (50-306802-50)	NA5190  42x56x7mm, FPM (50-307352-70) NB645  35x50x7mm, MVQ NB847  88x108x11mm, FPM (50-307171-70)	NB596 [2]  NB655 [2]  NA579 [2]  NA585 [2] 	JH5015 JJ348	



KW/PS



Escort 1.4L 01/94 → 02/99 21						BY740 (Fibre) (30-025122-20)	DY741	EA441 (22-25409-00/0)		
Escort 1.4L i 08/93 → 01/95										
Escort Convertible 1.4L i 07/93 → 01/95										
F4B/FUH	1392	4	77.24	Injection, PTE	55/75					
Escort 1.6L 07/90 → 12/92 22						BJ440 (Fibre) (30-025123-20)	DJ444 (21-24964-22/0)	EA441 (22-25409-00/0)		
Escort Convertible 1.6L 07/90 → 12/92										
LJF	1597	4	79.96	EFi, CVH	75-81/ 102- 110					
Escort 1.6L 09/80 → 12/85 23						BJ440 (Fibre) (30-025123-20)	DJ440	EA440 (22-24480-00/0)		
Escort Convertible 1.6L 09/80 → 12/85										
LP1/LPA	1597	4	79.96	Carburettor, CVH	58/79					
Escort 1.6L 01/86 → 08/92 24						BJ440 (Fibre) (30-025123-20)	DJ442	EA441 (22-25409-00/0)		
Escort Convertible 1.6L 01/86 → 12/87										
LP2	1597	4	79.96	Carburettor, CVH	58/79					
LP2	1597	4	79.96		60/81					
LUI/LUK	1597	4	79.96	Carburettor, CVH	65/66/ 71/88/ 90/96					
LUG	1597	4	79.96	Carburettor, CVH	65-66/ 88-90					
Escort 1.6L 16V 01/95 → 07/00 25						BW630 (Fibre) (30-028039-00)	DW630 (21-28423-20/0)	EW630 (22-28450-00/0)		
Escort 1.6L 16V 4x4 01/95 → 10/98										
Escort 1.6L i 16V 01/95 → 02/99										
Escort Convertible 1.6L 16V XR3i 02/95 → 09/99										
L1H	1597	4	76.00	DOHC	65/88					
L1E	1597	4	76.00	DOHC	66/90					
L1K	1597	4	76.00	Injection, DOHC	66/90					
Escort 1.6L D Diesel 02/84 → 07/90 26						BM950 (Fibre), 1.36mm, 2 Holes (30-024950-10) BM960 (Fibre), 1.42mm, 3 Holes (30-024951-10) BM980 (Fibre), 1.52mm, 4 Holes (30-026287-10)	DM940▲ (21-24949-21/0)	EM940		
Escort 1.6L i 07/85 → 07/90 27										
Escort 1.6L XR3i 01/86 → 08/89										
Escort Convertible 1.6L i 01/86 → 07/90						BJ440 (Fibre) (30-025123-20)	DJ441 (21-24964-21/0)	EA441 (22-25409-00/0)		
Escort Convertible 1.6L XR3i 01/86 → 07/90										
LR2/LRB	1597	4	79.96	Injection, CVH	66/77/ 90/105					
L4B	1598	4	79.96	Injection, CVH	66/77/ 90/105					

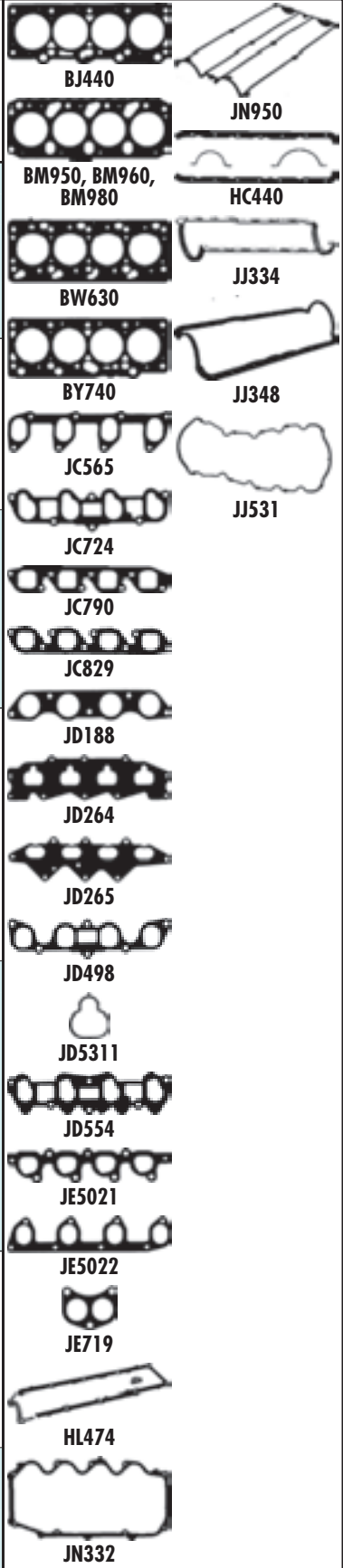









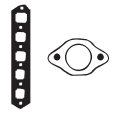

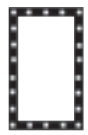

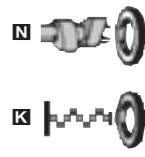















































































								
HBS001  (22-18083B) M10x1.50x135mm (x10)	JD188  (31-027056-00) JD554  (31-029517-00) JC829  (31-025656-10)	JN332 (31-024964-10)	JJ348 (50-025409-10)	HR631  (24-30612-25/0) HR661  [1] (50-306802-50)	NA5190 42x56x7mm, FPM (50-307352-70) NB645  35x50x7mm, MVQ NB847  88x108x11mm, FPM (50-307171-70)			
HBS001  (22-18083B) M10x1.50x135mm (x10)	JD188  (31-027056-00) JC724  (31-027055-00) JC829  (31-025656-10)	JN332 (31-024964-10)	JJ348 (50-025409-10)	HR661  [1] (50-306802-50)	NA5190  42x56x7mm, FPM (50-307352-70) NB645  35x50x7mm, MVQ NB847  88x108x11mm, FPM (50-307171-70)			
HBS001  (22-18083B) M10x1.50x135mm (x10)	JD498  (31-024472-10) JD5746  (31-025159-10) JC829  (31-025656-10)  JE719	JN332 (31-024964-10)	HC440  (23-24480-00/0)	HR631  (24-30612-25/0) HR661  [1] (50-306802-50)	NA5190 42x56x7mm, FPM (50-307352-70) NB645  35x50x7mm, MVQ NB847  88x108x11mm, FPM (50-307171-70)	NB596 [2]  NB655 [2]  NA585 [2] 		
HBS001  (22-18083B) M10x1.50x135mm (x10)	JD498  (31-024472-10) JC790  (31-024473-20)  JE719	JN332 (31-024964-10)	JJ348 (50-025409-10)	HR631  (24-30612-25/0) HR661  [1] (50-306802-50)	NA5190  42x56x7mm, FPM (50-307352-70) NB645  35x50x7mm, MVQ NB847  88x108x11mm, FPM (50-307171-70)	NB596 [2]  NB655 [2]  NA579 [2] 		
HBS031  (22-18008B) M10x1.50x102mm (x10)	JD265  (31-028392-00) →07/95 JD264  (31-028430-00) JD5311  (x4) (50-029872-00) 08/95 → JE5021  (31-028435-00)	JN950 (50-028423-00)	JJ531 (50-028450-00)	HR5033  (24-30715-70/0)	NB958  (x2) 42x53x7mm, FPM (50-319323-00) NB959  35x50x7mm, FPM (50-306644-50) NB847  88x108x11mm, FPM (50-307171-70)			
HBS007  (22-18085B)	JC565  (31-025104-10) JE5022  (31-025105-10)	HL474  (24-24961-00/0)	JJ334 (50-024962-00)	HR659  (24-30591-25/0)	NB785  28x38x7mm, FPM (50-305940-50) NB786  42x58x11mm, FPM (50-305941-50) NB788  79.4x95.3x11.1mm, PTFE (50-306413-50)	NB596 [2]  NB655 [2]  NA585 [2] 		
HBS001  (22-18083B) M10x1.50x135mm (x10)	JD498  (31-024472-10) JD5746  (31-025159-10) JC829  (31-025656-10)  JE719	JN332 (31-024964-10)	JJ348 (50-025409-10)	HR631  (24-30612-25/0) HR661  [1] (50-306802-50)	NA5190  42x56x7mm, FPM (50-307352-70) NB645  35x50x7mm, MVQ NB847  88x108x11mm, FPM (50-307171-70)	NB596 [2]  NB655 [2]  NA585 [2] 		



KW/PS



Escort 1.6L i 08/89 → 07/90 28						BJ440 (Fibre) (30-025123-20)	DJ444 (21-24964-22/0)	EA441 (22-25409-00/0)
Escort 1.6L Mk IV 04/87 → 08/89								
Escort Convertible 1.6L i 08/89 → 07/90								
LJB/LRB	1597	4	79.96	Injection, CVH	66/77/ 90/105			
Escort 1.6L i 16V 09/92 → 08/95 29						BW630 (Fibre) (30-028039-00)	DW630 (21-28423-20/0)	EW630 (22-28450-00/0)
Escort Convertible 1.6L 16V XR3i 12/92 → 01/95								
Escort Convertible 1.6L i 16V 02/94 → 01/95								
L1H	1597	4	76.00	DOHC	65/88			
L1E	1597	4	76.00	DOHC	66/90			
L1K	1597	4	76.00	Injection, DOHC	66/90			
Escort 1.6L RS Turbo 11/84 → 12/85 30						BN470 (Fibre)	DN470	
LNA	1597	4	79.96	Injection, CVH	97/132			
Escort 1.6L Turbo RS 01/86 → 07/90 31						BN470 (Fibre)	DN471	EA441 (22-25409-00/0)
LNB	1597	4	79.96	Injection, CVH	97/132			
Escort 1.6L XR3i 10/82 → 12/85 32						BJ440 (Fibre) (30-025123-20)	DJ441 (21-24964-21/0)	EA440 (22-24480-00/0)
Escort Convertible 1.6L i 09/83 → 12/85								
LR1/LRA	1597	4	79.96	Injection, CVH	66/77/ 90/105			
Escort Mexico 01/70 → 10/75 33						BJ200 (Fibre)	DJ202	EH750
KL16H (711M)	1599	4	80.98		63/86			
Escort Mexico 1600RS 01/75 → 12/79 34						AH850 (Fibre) (30-022666-20)	CH851 (21-22641-20/0)	EH850 (22-22677-00/0)
LAT/LCR	1594	4	87.65	SOHC	46-48/ 63-65			
Escort RS 1600i 05/82 → 12/85 35						BJ440 (Fibre) (30-025123-20)	DJ441 (21-24964-21/0)	EA440 (22-24480-00/0)
HL16i	1597	4	79.96		85/115			
Escort Twin Cam 03/68 → 08/71 36						AF880 (Fibre)	CF880	EH761
125E, 3020E	1558	4	82.55		80/109			

									
HBS001  (22-18083B) M10x1.50x135mm (x10)	JD498  (31-024472-10) JD188  (31-027056-00) JC724  (31-027055-00) JC829  (31-025656-10)	JN332 (31-024964-10)	JJ348 (50-025409-10)	HR631  (24-30612-25/0) HR661  [1] (50-306802-50)	NA5190  42x56x7mm, FPM (50-307352-70) NB645  35x50x7mm, MVQ NB847  88x108x11mm, FPM (50-307171-70)			AF880 AH850 BJ200 BJ440 BN470 BW630 JA475 JA613 JA768 JA769 JA770 JB811 JB812 JC724 JC829 JD188 JD264 JD265 JD498 JE5021	JE719 JM460 JM478 JM510 JN332 JN950 HC070 HC285 HC440 JJ348 JJ531
HBS031  (22-18008B) M10x1.50x102mm (x10)	JD265  (31-028392-00) JD264  (31-028430-00) JE5021  (31-028435-00)	JN950 (50-028423-00)	JJ531 (50-028450-00)	HR5033  (24-30715-70/0)	NB958  (x2) 42x53x7mm, FPM (50-319323-00) NB959  35x50x7mm, FPM (50-306644-50) NB847  88x108x11mm, FPM (50-307171-70)			JA475 JA613 JA768 JA769 JA770 JB811 JB812 JC724 JC829 JD188 JD264 JD265 JD498 JE5021	JM510 JN332 JN950 HC070 HC285 HC440 JJ348 JJ531
HBS001  (22-18083B) M10x1.50x135mm (x10)	JD5746  (31-025159-10)	JN332 (31-024964-10)		HR661  [1] (50-306802-50)	NA5190  42x56x7mm, FPM (50-307352-70) NB959  35x50x7mm, FPM (50-306644-50) NB847  88x108x11mm, FPM (50-307171-70)			JA475 JA613 JA768 JA769 JA770 JB811 JB812 JC724 JC829 JD188 JD264 JD265 JD498 JE5021	JN950 HC070 HC285 HC440 JJ348 JJ531
HBS001  (22-18083B) M10x1.50x135mm (x10)	JD498  (31-024472-10) JD5746  (31-025159-10)	JN332 (31-024964-10)	JJ348 (50-025409-10)	HR631  (24-30612-25/0) HR661  [1] (50-306802-50)	NA5190  42x56x7mm, FPM (50-307352-70) NB645  35x50x7mm, MVQ NB847  88x108x11mm, FPM (50-307171-70)	NB596 [2]  NB655 [2]  NA585 [2] 		JA768 JA769 JA770 JB811 JB812 JC724 JC829 JD188 JD264 JD265 JD498 JE5021	HC070 HC285 HC440 JJ348 JJ531
HBS001  (22-18083B) M10x1.50x135mm (x10)	JD498  (31-024472-10) JD5746  (31-025159-10) JC829  (31-025656-10)  JE719	JN332 (31-024964-10)	HC440  (23-24480-00/0)	HR631  (24-30612-25/0) HR661  [1] (50-306802-50)	NA5190  42x56x7mm, FPM (50-307352-70) NB645  35x50x7mm, MVQ NB847  88x108x11mm, FPM (50-307171-70)	NB596 [2]  NB655 [2]  NA585 [2] 		JA770 JB811 JB812 JC724 JC829 JD188 JD264 JD265 JD498 JE5021	HC440 JJ348 JJ531
	JA613  (31-022298-10) JB811  (31-022293-10) JB812  (x2)	JM478 (31-022174-00)	HC070  (50-022354-10)	HR632  (50-022354-10)	NA576 36.5x52.3x8mm, MVQ (50-306573-00) NA576  36.5x52.3x8mm, MVQ (50-306573-00) NA793  79x95.3x11.1mm, MVQ	NA580 [2]  JR265 [1] [1]		JA613 JB811 JB812 JC724 JC829 JD188 JD264 JD265 JD498 JE5021	JM478 JN332 JN950 HC070 HC285 HC440 JJ348 JJ531
	JA769  (31-022642-10) JA768  (31-022672-10) JA770  (x3) (31-022671-10)	JM510 (31-022641-20)	HC285  (23-22677-00/0)	HR631  (24-30612-25/0) HR661  [1] (50-306802-50)	NA5190 (x2) 42x56x7mm, FPM (50-307352-70) NA5190  42x56x7mm, FPM (50-307352-70) NA793  79x95.3x11.1mm, MVQ	NA580 [2]  NA585 [2]  NA583 [2]  KA289 [1] [3] KT738 [1] [4]		JA769 JA768 JA770 JB811 JB812 JC724 JC829 JD188 JD264 JD265 JD498 JE5021	JM510 JN332 JN950 HC070 HC285 HC440 JJ348 JJ531
HBS001  (22-18083B) M10x1.50x135mm (x10)	JD498  (31-024472-10) JC829  (31-025656-10)  JE719	JN332 (31-024964-10)	HC440  (23-24480-00/0)	HR631  (24-30612-25/0) HR661  [1] (50-306802-50)	NA5190  42x56x7mm, FPM (50-307352-70) NB645  35x50x7mm, MVQ NB847  88x108x11mm, FPM (50-307171-70)	NB596 [2]  NB655 [2]  NA585 [2] 		JA768 JA769 JA770 JB811 JB812 JC724 JC829 JD188 JD264 JD265 JD498 JE5021	JN332 JN950 HC070 HC285 HC440 JJ348 JJ531
	JA475  (x4)	JM460	HC060 		NA576  36.5x52.3x8mm, MVQ (50-306573-00) NA793  79x95.3x11.1mm, MVQ	NA580 [2] 		JA475 JA613 JA768 JA769 JA770 JB811 JB812 JC724 JC829 JD188 JD264 JD265 JD498 JE5021	JM460 JN332 JN950 HC070 HC285 HC440 JJ348 JJ531











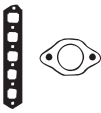

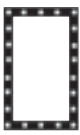

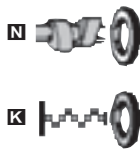











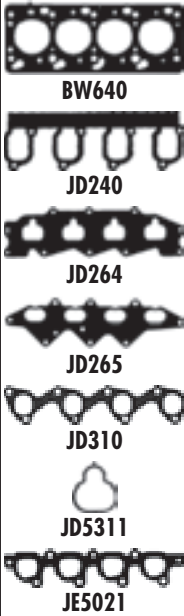









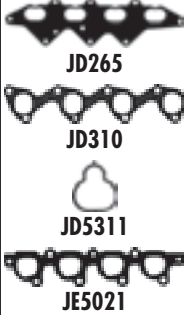











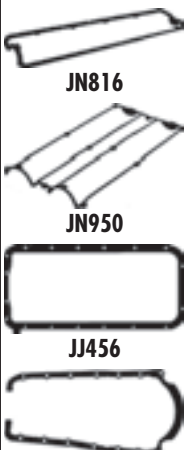

FORD



KW/PS



Escort 1.8L i 16V 09/92 → 01/95 37						BW640 (Fibre) (30-028040-00)	DW640	EW630 (22-28450-00/0)			
Escort 1.8L XR3i 16V 09/92 → 01/95											
Escort 16V XR3i 02/92 → 01/95											
Escort Convertible 1.8L 16V XR3i 12/92 → 01/95											
Escort 1.8L 16V 02/92 → 08/95											
RDA	1796	4	80.60		77/105						
RDA	1796	4	80.60	DOHC	77/105						
RQB	1796	4	80.60	DOHC	96/131						
Escort 1.8L 16V 01/95 → 02/99 38						BW640 (Fibre) (30-028040-00)	DW640	EW630 (22-28450-00/0)			
Escort Convertible 1.8L 16V XR3i 02/95 → 08/00											
RDA	1796	4	80.60		77/105						
RKC	1796	4	80.60	DOHC	85/115						
RQB	1796	4	80.60	DOHC	96/131						
Escort 1.8L D Diesel 07/88 → 07/90 39						BT190 (Fibre), 1.36mm, 2 Teeth [4] (30-026353-10) ☞ 0.43 → 0.68mm BT200 (Fibre), 1.42mm, 3 Teeth [4] (30-026354-10) ☞ 0.681 → 0.74mm BT210 (Fibre), 1.52mm, 4 Teeth [4] (30-026355-10) ☞ 0.741 → 0.86mm	DT193▲ (21-26448-21/0)	ET190 [27] (22-26449-00/0) ET191 [6] (22-28438-00/0)			
RTA/RTB 1753 4 82.50 Indirect Injection 44/60											
Escort 1.8L D Diesel 07/90 → 12/92 40									BT190 (Fibre), 1.36mm, 2 Teeth [4] (30-026353-10) ☞ 0.43 → 0.68mm BT200 (Fibre), 1.42mm, 3 Teeth [4] (30-026354-10) ☞ 0.681 → 0.74mm BT210 (Fibre), 1.52mm, 4 Teeth [4] (30-026355-10) ☞ 0.741 → 0.86mm	DT193▲ (21-26448-21/0)	ET190 [27] (22-26449-00/0) → 11/93 ET191 [6] (22-28438-00/0) → 11/93 ET192
RTE/RTF/RTH 1753 4 82.50 Indirect Injection 44/60											

								 BT190, BT200, BT210	 JJ531
HBS031  (22-18008B) M10x1.50x102mm (x10)	JD265  (31-028392-00) JD264  (31-028430-00) JE5021  (31-028435-00)	JN950 (50-028423-00)	JJ531 (50-028450-00)	HR5033  (24-30715-70/0)	NB958  (x2) 42x53x7mm, FPM (50-319323-00) NB959  35x50x7mm, FPM (50-306644-50) NB847  88x108x11mm, FPM (50-307171-70)				
HBS031  (22-18008B) M10x1.50x102mm (x10)	JD265  (31-028392-00) →07/95 JD264  (31-028430-00) JD5311  (x4) (50-029872-00) 08/95→ JE5021  (31-028435-00)	JN950 (50-028423-00)	JJ531 (50-028450-00)	HR5033  (24-30715-70/0)	NB958  (x2) 42x53x7mm, FPM (50-319323-00) NB959  35x50x7mm, FPM (50-306644-50) NB847  88x108x11mm, FPM (50-307171-70)				
HBS007  (22-18008B) →07/92 HBS033  (22-18007B) M12x1.75x136mm (x10) 07/92→	JD240  (31-026450-00) JD310  (31-026847-00)	JN816 (50-026448-10)	JJ456 [6] (50-026449-00) JJ463 [5] (50-028438-00)	HR659  (24-30591-25/0)	NB785 28x38x7mm, FPM (50-305940-50) NB984  66.67x89.3x10mm, FPM (50-306841-50) NA793  79x95.3x11.1mm, MVQ	HL5018 [245]  NB596 [2]  NA585 [2]  NJ004 [2] 			
HBS007  (22-18008B) →07/92 HBS033  (22-18007B) M12x1.75x136mm (x10) 07/92→	JD240  (31-026450-00) JD310  (31-026847-00)	JN816 (50-026448-10)	JJ456 [6] (50-026449-00) JJ463 [5] (50-028438-00)	HR659  (24-30591-25/0)	NB785 28x38x7mm, FPM (50-305940-50) NB984  66.67x89.3x10mm, FPM (50-306841-50) NA793  79x95.3x11.1mm, MVQ	HL5018 [245]  NB596 [2]  NA585 [2]  NJ004 [2] 			





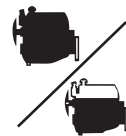

KW/PS

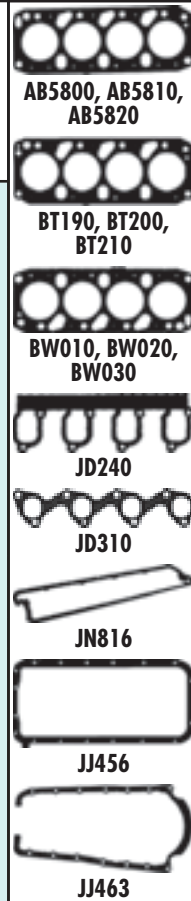
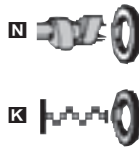
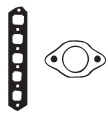

Escort 1.8L D Diesel		07/90 → 12/94		41				
RTH	1753	4	82.50	Indirect Injection	44/60	BT190 (Fibre), 1.36mm, 2 Teeth [4] (30-026353-10) →09/92 ☞0.43 →0.68mm BT200 (Fibre), 1.42mm, 3 Teeth [4] (30-026354-10) →08/92 ☞0.681 →0.74mm BT210 (Fibre), 1.52mm, 4 Teeth [4] (30-026355-10) →08/92 ☞0.741 →0.86mm BW010 (Fibre), 1.36mm, 2 Notches (30-027536-00) 09/92 → ☞0.43 →0.68mm AB5800 (Fibre), 1.36mm, 2 Teeth [4] (30-027530-00) 09/92 → ☞0.43 →0.68mm BW020 (Fibre), 1.42mm, 3 Notches (30-027537-00) 09/92 → ☞0.681 →0.74mm AB5810 (Fibre), 1.42mm, 3 Teeth [4] (30-027531-00) 09/92 → ☞0.681 →0.74mm BW030 (Fibre), 1.52mm, 4 Notches (30-027538-00) 09/92 → ☞0.741 →0.86mm AB5820 (Fibre), 1.52mm, 4 Teeth [4] (30-027532-00) 09/92 → ☞0.741 →0.86mm	DT193▲ (21-26448-21/0)	ET190 [27] (22-26449-00/0) →11/93 ET191 [6] (22-28438-00/0) →11/93 ET192 11/93 →
Escort 1.8L D Diesel		09/92 → 01/95		42				
RTE/RTF/RTH	1753	4	82.50	Indirect Injection	44/60	BW010 (Fibre), 1.36mm, 2 Notches (30-027536-00) ☞0.43 →0.68mm AB5800 (Fibre), 1.36mm, 2 Teeth [4] (30-027530-00) ☞0.43 →0.68mm BW020 (Fibre), 1.42mm, 3 Notches (30-027537-00) ☞0.681 →0.74mm AB5810 (Fibre), 1.42mm, 3 Teeth [4] (30-027531-00) ☞0.681 →0.74mm BW030 (Fibre), 1.52mm, 4 Notches (30-027538-00) ☞0.741 →0.86mm AB5820 (Fibre), 1.52mm, 4 Teeth [4] (30-027532-00) ☞0.741 →0.86mm	DT193▲ (21-26448-21/0)	ET190 [27] (22-26449-00/0) →11/93 ET191 [6] (22-28438-00/0) →11/93 ET192 11/93 →









HBS007 
 (22-18085B)
 →08/92
HBS033 
 (22-18007B)
 M12x1.75x136mm (x10)
 09/92→





JD240 
 (31-026450-00)
JD310 
 (31-026847-00)



JN816
 (50-026448-10)



JJ456 [6]
 (50-026449-00)
JJ463 [5]
 (50-028438-00)

HR659 
 (24-30591-25/0)
 →08/92
HR801 
 09/92→

 **NB785** 28x38x7mm, FPM
 (50-305940-50)
 **NB984** 66.67x89.3x10mm, FPM
 (50-306841-50)
 **NA793** 79x95.3x11.1mm, MVQ
 **NC086** [3] 79.8x184x18.8mm,
 PTFE
 (50-319517-00)

HL5018 [245] 
NB596 [2] 
NA585 [2] 
NJ004 [2] 





HBS007 
 (22-18085B)
 →07/92
HBS033 
 (22-18007B)
 M12x1.75x136mm (x10)
 07/92→





JD240 
 (31-026450-00)
JD310 
 (31-026847-00)

JN816
 (50-026448-10)

JJ456 [6]
 (50-026449-00)
JJ463 [5]
 (50-028438-00)

HR801 

 **NB785** 28x38x7mm, FPM
 (50-305940-50)
 **NB984** 66.67x89.3x10mm, FPM
 (50-306841-50)
 **NA793** 79x95.3x11.1mm, MVQ
 **NC086** [3] 79.8x184x18.8mm,
 PTFE
 (50-319517-00)







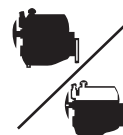



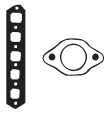

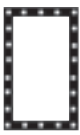

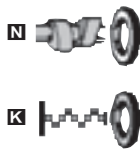

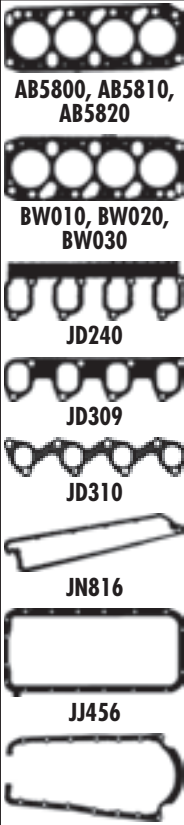

















HL5018 [245] 
NB596 [2] 
NA585 [2] 
NJ004 [2] 
NC044 [15]



KW/PS



Escort 1.8L TD Diesel				02/93 → 07/00		43			
RFD/RFK	1753	4	82.50	Indirect Injection	66/89	BW010 (Fibre), 1.36mm, 2 Notches (30-027536-00) → 0.43 → 0.68mm	DT193▲ (21-26448-21/0)	ET190 [5] (22-26449-00/0) → 11/93 ET191 [6] (22-28438-00/0) → 11/93 ET192 11/93 →	
RFS	1753	4	82.50		66/89	AB5800 (Fibre), 1.36mm, 2 Teeth [4] (30-027530-00) → 0.43 → 0.68mm BW020 (Fibre), 1.42mm, 3 Notches (30-027537-00) → 0.681 → 0.74mm AB5810 (Fibre), 1.42mm, 3 Teeth [4] (30-027531-00) → 0.681 → 0.74mm BW030 (Fibre), 1.52mm, 4 Notches (30-027538-00) → 0.741 → 0.86mm AB5820 (Fibre), 1.52mm, 4 Teeth [4] (30-027532-00) → 0.741 → 0.86mm			
Escort 1.8L D Diesel				01/95 → 02/99		44		DT193▲ (21-26448-21/0)	ET192
Escort Van 1.8L D Diesel				01/95 →					
RTE	1753	4	82.50	Indirect Injection	44/60	BW010 (Fibre), 1.36mm, 2 Notches (30-027536-00) → 0.43 → 0.68mm AB5800 (Fibre), 1.36mm, 2 Teeth [4] (30-027530-00) → 0.43 → 0.68mm BW020 (Fibre), 1.42mm, 3 Notches (30-027537-00) → 0.681 → 0.74mm AB5810 (Fibre), 1.42mm, 3 Teeth [4] (30-027531-00) → 0.681 → 0.74mm BW030 (Fibre), 1.52mm, 4 Notches (30-027538-00) → 0.741 → 0.86mm AB5820 (Fibre), 1.52mm, 4 Teeth [4] (30-027532-00) → 0.741 → 0.86mm			
RTE, RTF, RTH	1753	4	82.50		44/60				
RTE/RTH	1753	4	82.50	Indirect Injection	44/60				
Escort 1.8L TD Diesel				12/95 → 02/99		45		DT193▲ (21-26448-21/0)	ET192
Escort Convertible 1.8L TD Diesel				09/95 → 08/99					
Escort Van 1.8L TD Diesel				12/95 → 06/01					
RVA	1753	4	82.50	Indirect Injection	51/70	BW010 (Fibre), 1.36mm, 2 Notches (30-027536-00) → 0.43 → 0.68mm AB5800 (Fibre), 1.36mm, 2 Teeth [4] (30-027530-00) → 0.43 → 0.68mm BW020 (Fibre), 1.42mm, 3 Notches (30-027537-00) → 0.681 → 0.74mm AB5810 (Fibre), 1.42mm, 3 Teeth [4] (30-027531-00) → 0.681 → 0.74mm BW030 (Fibre), 1.52mm, 4 Notches (30-027538-00) → 0.741 → 0.86mm AB5820 (Fibre), 1.52mm, 4 Teeth [4] (30-027532-00) → 0.741 → 0.86mm			
RFD/RFK	1753	4	82.50	Indirect Injection	66/89				







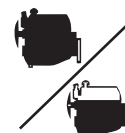



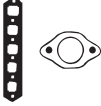

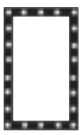

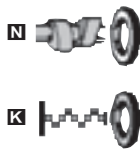

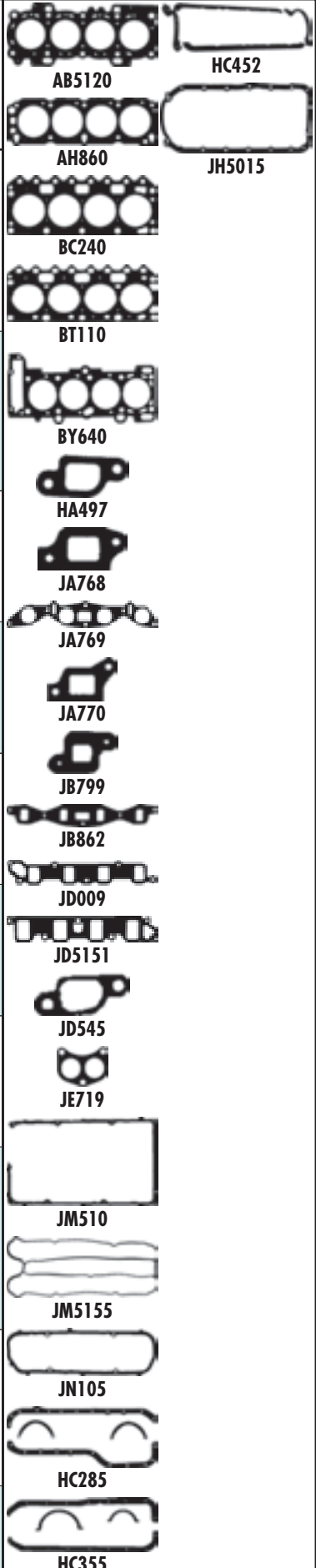















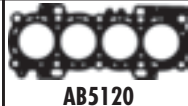

















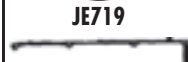







































































































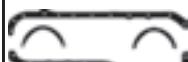

							
HBS033  (22-18007B) M12x1.75x136mm (x10)	JD309  (31-026846-00) JD310  (31-026847-00)	JN816 (50-026448-10)	JJ456 [6] (50-026449-00) JJ463 [5] (50-028438-00)	HR801 	▣ NB785 28x38x7mm, FPM (50-305940-50) ▣ NB984  66.67x89.3x10mm, FPM (50-306841-50) ▣ NA793  79x95.3x11.1mm, MVQ ▣ NC086  [3] 79.8x184x18.8mm, PTFE (50-319517-00)	HL5018 [245]  NC044 [15]	
HBS033  (22-18007B) M12x1.75x136mm (x10)	JD240  (31-026450-00) JD310  (31-026847-00)	JN816 (50-026448-10)	JJ463 (50-028438-00)	HR801 	▣ NB785 28x38x7mm, FPM (50-305940-50) ▣ NB984  66.67x89.3x10mm, FPM (50-306841-50) ▣ NA793  79x95.3x11.1mm, MVQ ▣ NC086  [3] 79.8x184x18.8mm, PTFE (50-319517-00)	HL5018 [245]  NB596 [2]  NA585 [2]  NJ004 [2]  NC044 [15]	
HBS033  (22-18007B) M12x1.75x136mm (x10)	JD309  (31-026846-00) JD310  (31-026847-00)	JN816 (50-026448-10)	JJ463 (50-028438-00)	HR801 	▣ NB785 28x38x7mm, FPM (50-305940-50) ▣ NB984  66.67x89.3x10mm, FPM (50-306841-50) ▣ NA793  79x95.3x11.1mm, MVQ ▣ NC086  [3] 79.8x184x18.8mm, PTFE (50-319517-00)	HL5018 [245]  NC044 [15]	



KW/PS

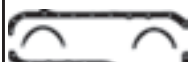

Model						Year Range	Code	Engine Type	Power (KW/PS)	Accessories	
Escort 2.0L RS						03/73 → 08/80	46	AH860 (Fibre)		CH861	EH850 (22-22677-00/0)
NEN	1993	4	90.80	Carburettor, SOHC	73/100						
NE	1993	4	90.80	Injection, DOHC	77/105						
Escort RS 2000						05/91 → 02/98	47	BY640 (MLS)		DY640	
Escort RS 2000 4x4						02/95 → 10/98		(30-028389-10)			
N7A	1998	4	86.00	Injection, DOHC	110/150						
Escort RS Cosworth						09/92 → 10/98	48				
NSF	1994	4	90.83	DOHC	162- 167/ 220- 227						
Fiesta 1.0L						09/83 → 11/89	49	BC240 (Fibre)		DC240■ (21-23756-21/0)	EG340 (22-23830-00/0)
TKB	1987	4	73.94	Carburettor, OHV	33/45		(30-023756-20)				
Fiesta 1.0L						03/89 → 12/95	50	BT110 (Fibre)		DT110 (21-26495-20/0)	EG340 (22-23830-00/0)
TLB	1989	4	68.70	Carburettor, HCS	33/45		(30-026495-00)				
Fiesta 1.0L i						02/97 → 09/99	51	BT110 (Fibre)			
	1997	4	68.70	OHC (HCS)	38/52		(30-026495-00)				
Fiesta 1.1L						02/81 → 02/89	52	BC240 (Fibre)		DC240■ (21-23756-21/0)	EG340 (22-23830-00/0)
GSH	1118	4	73.94	Carburettor, OHV	36/49		(30-023756-20)				
GLC	1118	4	73.94	Carburettor, OHV	37/50						
GSF	1118	4	73.94	Carburettor, CVH	37/50						
GLW	1118	4	73.94	Carburettor, OHV	40/54						
Fiesta 1.1L						03/89 → 12/95	53	BT110 (Fibre)		DT110 (21-26495-20/0)	EG340 (22-23830-00/0) → 03/92 EH752 04/92 →
G6A	1118	4	68.70	CFi, HCS	37/50		(30-026495-00)				
GUD/GUE	1118	4	68.70	Carburettor, HCS	40/55						
Fiesta 1.25 i 16V						03/03 →	54	AG8310 (Steel)		CB5120 (21-29248-00/0)	EB5120
M7JA/M7JB	1242	4	71.90	Injection	51/70		(30-030170-00)				
Fiesta 1.25 i 16V						05/02 →	55	AB5120 (MLS)		CB5120 (21-29248-00/0)	EB5120
FUJA/FUJB	1242	4	71.90	Injection, DOHC	55/75		(30-029248-00) → 12/02 AG8310 (Steel) (30-030170-00) 12/02 →				

								
HBS056  (22-18002B) M12x1.75x92.5mm (x10)	JA769  (31-022642-10) JA768  (31-022672-10) JA770  (x3) (31-022671-10) 	JM510 (31-022641-20)	HC285  (23-22677-00/0)	HR631  (24-30612-25/0) HR661  [1] (50-306802-50)	 NA5190  (x2) 42x56x7mm, FPM (50-307352-70)  NA5190 42x56x7mm, FPM (50-307352-70)  NA793 79x95.3x11.1mm, MVQ	NA580 [2]  NA585 [2]  NB655 [2]  KA289 [13] KT738 [14]	 AB5120  AH860  NA585  NB655  BC240  BT110  BY640  HA497  JA768  JA769  JA770  JB799  JB862  JD009  JD5151  JD545  JE719  JM510  JM5155  JN105  HC285  HC355  HC452  JH5015	
HBS032  (22-18003B) M11x1.50x178mm (x10)				HR655  24-30691-15/0	 NA5190 42x56x7mm, FPM (50-307352-70)  NA5190 42x56x7mm, FPM (50-307352-70)  NB847 88x108x11mm, FPM (50-307171-70)		 BY640  HA497  JA768  JA769  JA770  JB799  JB862  JD009  JD5151  JD545  JE719	
HBS032  (22-18003B) M11x1.50x178mm (x10)							 JA768  JA769  JA770  JB799  JB862  JD009  JD5151  JD545  JE719	
HBS050  (22-18001B) M11x1.50x120mm (x10)	JB862  (31-023758-10) JB799  (x4) (31-023762-20)	JN105 (31-027902-00)	HC355  (23-23528-00/0)	HR631  (24-30612-25/0) HR661  [1] (50-306802-50)	 NB572 50x70x6mm, NBR  NA576 36.5x52.3x8mm, MVQ (50-306573-00)  NB564 60.5x76.2x10mm, FPM (50-307219-70)	NA579 [2]  NB655 [2] 	 JA769  JA770  JB799  JB862  JD009  JD5151  JD545  JE719	
HBS050  (22-18001B) M11x1.50x120mm (x10)	JD009  (31-026514-00) JD545  (x4) (31-029228-00) HA497  	JN105 (31-027902-00)	HC355  (23-23528-00/0)	HR655  24-30691-15/0	 NB572 50x70x6mm, NBR  NA576 36.5x52.3x8mm, MVQ (50-306573-00)  NB564 60.5x76.2x10mm, FPM (50-307219-70)	NA585 [2] 	 JB862  JD009  JD5151  JD545  JE719	
HBS050  (22-18001B) M11x1.50x120mm (x10)	JB862  (31-023758-10) JB799  (x4) (31-023762-20)	JN105 (31-027902-00)	HC355  (23-23528-00/0)	HR631  (24-30612-25/0) HR661  [1] (50-306802-50)	 NA576 36.5x52.3x8mm, MVQ (50-306573-00)  NB564 60.5x76.2x10mm, FPM (50-307219-70)	NA585 [2] 	 JD545  JE719	
HBS050  (22-18001B) M11x1.50x120mm (x10)	JD009  (31-026514-00) JD545  (x4) (31-029228-00) HA497  	JN105 (31-027902-00)	HC355  (23-23528-00/0) →03/92 HC452  (23-23528-02/0) 04/92→	HR655  24-30691-15/0	 NA576 36.5x52.3x8mm, MVQ (50-306573-00)  NB564 60.5x76.2x10mm, FPM (50-307219-70) →03/92  NA793 79x95.3x11.1mm, MVQ 04/92→		 JM510  JM5155  JN105  HC285  HC355	
HBS078  (22-18086B) M10x1.50x143mm (x10)	JD5866  (50-030340-00)	JM5155 [17] (50-029587-00)		HR809   (50-319363-00) HR808   (50-319362-00)	 NC048 (x2) 37.2x52.35x6mm, FPM (50-319368-00)  NA5137 32.9x47.4x5mm, FPM (50-319367-00)  LK5004 [3] 80x182x19.4mm, PTFE (50-307318-70)		 JM5155  JN105  HC285  HC355	
HBS078  (22-18086B) M10x1.50x143mm (x10)	JD5866  (50-030340-00)	JM5155 [17] (50-029587-00)		HR809   (50-319363-00) HR808   (50-319362-00)	 NC048 (x2) 37.2x52.35x6mm, FPM (50-319368-00)  NA5137 32.9x47.4x5mm, FPM (50-319367-00)  LK5004 [3] 80x182x19.4mm, PTFE (50-307318-70)		 HC285  HC355	







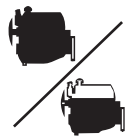



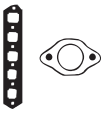

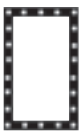

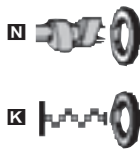





























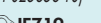

















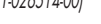
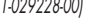













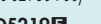

















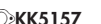







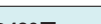
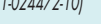









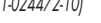













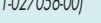
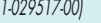













FORD



KW/PS



Fiesta 1.25 i 16V		08/95 → 01/02		56		BY650 (MLS) (30-028754-00) →04/98 AB5120 (MLS) (30-029248-00) 05/98 →		DY650 (21-28754-20/0) →04/98 DY651 (21-28754-21/0) 05/98 →		EY650 (22-28750-00/0)	
DHA/DHB/DHC/DHD/DHE/DHF/DHG	1242	4	71.90	Injection, DOHC	55/75						
Fiesta 1.3L		09/83 → 01/87		57		BJ440 (Fibre) (30-025123-20)		DJ440		EA440 (22-24480-00/0) →12/85 EA441 (22-25409-00/0) 01/86 →	
JPC	1296	4	79.96	Carburettor, CVH	51/69						
Fiesta 1.3L		03/89 → 12/95		58		BT140 (Fibre) (30-026496-00)		DT140 (21-26496-20/0)		EH752	
Fiesta Van 1.3L		09/91 → 02/96									
J6B	1297	4	73.96	CFi, HCS	44/60						
JBC	1297	4	73.96	Carburettor, HCS	44/46/ 60/63						
Fiesta 1.3L		11/01 →		59		AD5020 (MLS) (30-029602-00)		CD5020 (21-26602-20/0)		EC5890 [12] (22-28811-00/0)	
BAJA	1299	4	74.00	Injection, SOHC	44/60						
A9JA/A9JB	1299	4	74.00	Injection, SOHC	51/69						
Fiesta 1.3L i		08/95 → 01/02		60		BT140 (Fibre) (30-026496-00)		DY671 (21-26496-21/0)		EY671 (22-29632-00/0)	
Fiesta Van 1.3L		02/96 →									
J4C/Endura E/JJA	1297	4	73.96	EFI	37/44/ 50/60						
JJC/JJE/Endura E/JJJ/JJK/JJM	1299	4	74.00	Injection	37/50						
J4J/J4L/J4Q/J4R/J4T	1299	4	74.00	Injection	44/60						
Fiesta 1.4L		10/86 → 12/95		61		BY740 (Fibre) (30-025122-20)		DY740 (21-24964-20/0)		EA441 (22-25409-00/0)	
F6E	1392	4	77.24	Injection, CVH	52/71						
F6C	1392	4	77.25	CFi, CVH	52/71						
F6A	1393	4	77.25	CFi, CVH	52-54/ 71-73						
Fiesta 1.4L		10/85 → 12/95		62		BY740 (Fibre) (30-025122-20)		DP790 (21-25122-21/0)		EA441 (22-25409-00/0)	
FUG/FUJ	1392	4	77.24	Injection, CVH	55/75						
FUD	1392	4	77.25	Carburettor, CVH	54/73						
FUB	1392	4	77.25	Carburettor, CVH	55/75						
Fiesta 1.4L		03/89 → 12/95		63		BY740 (Fibre) (30-025122-20)		DY741		EA441 (22-25409-00/0)	
F4A	1392	4	77.24	Injection, PTE	55/75						
Fiesta 1.4L 16V		11/01 →		64		AB5130 (MLS) (30-029249-00)		CB5132 (21-29249-10/0)		EB5120	
FXJA/FXJB	1388	4	76.00	SPi, DOHC	59/80						

								
HBS078  (22-18086B) M10x1.50x143mm (x10)	JD5230  (x2) (50-028751-00) JD5164  (31-029032-00)	JM5155 [17] (50-029587-00)	JE5025 (31-028750-00)	HR809  (50-319363-00) HR808  (50-319362-00)	NA5137  (50-319367-00) LK5004  [3] 80x182x19.4mm, PTFE (50-307318-70)			 AB5120  AB5130  AD5020  BJ440  BT140  BY650  BY740  HA497  JC790  JC829  JD009  JD188  JD498  JD5151  JD5164  JD5230  JD545  JD554  JE719
HBS001  (22-18083B) M10x1.50x135mm (x10)	JD498  (31-024472-10) JC829  (31-025656-10)  JE719	JN332 (31-024964-10)	HC440  (23-24480-00/0) →12/85 JJ348 (50-025409-10) 01/86→	HR631  (24-30612-25/0) HR661  [1] (50-306802-50)	NA5190  42x56x7mm, FPM (50-307352-70) NB645  35x50x7mm, MVQ NB847  88x108x11mm, FPM (50-307171-70)	NB596 [2]  NA585 [2] 		 JM5155  JN105  JN332  HC440  HC452  JE5025  JH5015  JJ348
HBS050  (22-18001B) M11x1.50x120mm (x10)	JD009  (31-026514-00) JD545  (x4) (31-029228-00) HA497 	JN105 (31-027902-00)	HC452  (23-23528-02/0)	HR655  24-30691-15/0	NB572  50x70x6mm, NBR NA576  36.5x52.3x8mm, MVQ (50-306573-00) NA793  79x95.3x11.1mm, MVQ NB788  79.4x95.3x11.1mm, PTFE (50-306413-50)	NB655 [2]  NA585 [2] 		 JM5104  JH5015  KA5021 [13]
HBS358  (22-18093B) M11x1.50x158mm (x10) M8x0.0x45mm (x2)	JD5220  (x2) (50-029604-00) JD5219  (31-029603-00)	JM5104 (50-029605-00)	JH5046 (31-029607-00)	PA5033 (x8) (50-319443-00)	NA5147  40x62x7.4mm, PTFE (50-319446-00) NA5130  [3] 79x196x21.5mm, PTFE (50-319444-00)			 JC790  JC829  JD009  JD188  JD498  JD5151  JD5164  JD5230  JD545  JD554  JE719
HBS050  (22-18001B) M11x1.50x120mm (x10)	JD5151  (31-029227-00) JD545  (x4) (31-029228-00) HA497   KK5157	JN105 (31-027902-00)	JH5015 (50-029632-00)	HR655  24-30691-15/0	NA576  36.5x52.3x8mm, MVQ (50-306573-00) NB788  79.4x95.3x11.1mm, PTFE (50-306413-50)			 JM5104  JH5015  KA5021 [13]
HBS001  (22-18083B) M10x1.50x135mm (x10)	JD498  (31-024472-10) JC790  (31-024473-20)	JN332 (31-024964-10)	JJ348 (50-025409-10)	HR631  (24-30612-25/0) HR661  [1] (50-306802-50)	NA5190  42x56x7mm, FPM (50-307352-70) NB645  35x50x7mm, MVQ NB847  88x108x11mm, FPM (50-307171-70)			 JM5104  JH5015  KA5021 [13]
HBS001  (22-18083B) M10x1.50x135mm (x10)	JD498  (31-024472-10) JC790  (31-024473-20)	JN332 (31-024964-10)	JJ348 (50-025409-10)	HR631  (24-30612-25/0) HR661  [1] (50-306802-50)	NA5190  42x56x7mm, FPM (50-307352-70) NB645  35x50x7mm, MVQ NB847  88x108x11mm, FPM (50-307171-70)	NB596 [2]  NB655 [2]  NA579 [2]  NA585 [2] 		 JM5104  JH5015  KA5021 [13]
HBS001  (22-18083B) M10x1.50x135mm (x10)	JD188  (31-027056-00) JD554  (31-029517-00) JC829  (31-025656-10)	JN332 (31-024964-10)	JJ348 (50-025409-10)	HR631  (24-30612-25/0) HR661  [1] (50-306802-50)	NA5190  42x56x7mm, FPM (50-307352-70) NB645  35x50x7mm, MVQ NB847  88x108x11mm, FPM (50-307171-70)			 JM5104  JH5015  KA5021 [13]
HBS078  (22-18086B) M10x1.50x143mm (x10)	JD5866  (50-030340-00) JD5164  (31-029032-00) →10/03	JM5155 [17] (50-029587-00)		HR809  (50-319363-00) HR808  (50-319362-00)	NA5137  32.9x47.4x5mm, FPM (50-319367-00) LK5004  [3] 80x182x19.4mm, PTFE (50-307318-70)			 JM5155  JN105  JN332  HC440  HC452  JE5025  JH5015  JJ348











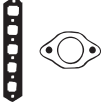

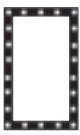

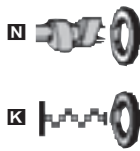













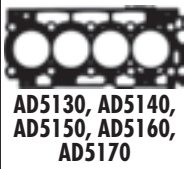





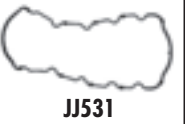













































































FORD



KW/PS



Fiesta 1.4L i		04/96 → 10/99		65		BY660 (MLS)		DY660		EY650	
Fiesta 1.4L i 16V		04/96 → 01/02				(30-028820-00)		(21-28820-20/0)		(22-28750-00/0)	
FHA/FHE	1388	4	76.00	Injection, DOHC	55/90	→05/98		→05/98			
FHA	1388	4	76.00		66/90	AB5130 (MLS)		CB5130 ^[17]			
						(30-029249-00)		(21-28820-30/0)			
						06/98 →		06/98 →			
Fiesta 1.4L TDCi Diesel		11/01 →		66		AD5130 (MLS), 1.25mm, 2 Notches, +3 Notches		CD5130▲		ED5130	
F6JA / DV4TD/F6JB	1398	4	73.70	Common Rail, SOHC	50/68	(30-029277-00)		(21-29277-00/0)			
						AD5140 (MLS), 1.30mm, 3 Notches, +3 Notches					
						(30-029278-00)					
						AD5150 (MLS), 1.35mm, 1 Notch, +3 Notches					
						(30-029279-00)					
						AD5160 (MLS), 1.40mm, +3 Notches, 4 Notches					
						(30-029280-00)					
						AD5170 (MLS), 1.45mm, +3 Notches, 5 Notches					
						(30-029281-00)					
Fiesta 1.6L XR2		03/84 → 02/89		67		BJ440 (Fibre)		DJ440		EA440	
LUB/LUD	1597	4	79.96	Carburettor, CVH	65/66/ 71/88/ 90/96	(30-025123-20)		→01/86		(22-24480-00/0)	
								DJ442		→12/85	
								02/86 →		EA441	
										(22-25409-00/0)	
										01/86 →	
Fiesta 1.6L XR2i		03/89 → 03/93		68		BJ440 (Fibre)		DJ444		EA441	
LJD	1597	4	79.96	EFi, CVH	75-81/ 102- 110	(30-025123-20)		(21-24964-22/0)		(22-25409-00/0)	
Fiesta 1.6L XR2i		03/89 → 01/94		69		BJ440 (Fibre)		DJ444		EA441	
LJC	1597	4	80.00	EFi, CVH	81/110	(30-025123-20)		(21-24964-22/0)		(22-25409-00/0)	
Fiesta 1.6L		01/89 → 01/94		70		BJ440 (Fibre)		DJ442		EA441	
LUH	1597	4	76.00	Carburettor, CVH	65/88	(30-025123-20)				(22-25409-00/0)	
Fiesta 1.6L Turbo		03/90 → 10/92		71		BN470 (Fibre)		DN472		EA441	
LHA	1597	4	79.96	CVH	96/131					(22-25409-00/0)	
Fiesta 1.6L i 16V		01/94 → 12/95		72		BW630 (Fibre)		DW630		EW630	
LIG	1597	4	76.00	Injection, DOHC	65-66/ 88-90	(30-028039-00)		(21-28423-20/0)		(22-28450-00/0)	

								
HBS078  [22-18086B] M10x1.50x143mm (x10)	JD5230  (x2) (50-028751-00) →05/98 JD5290  (x2) (50-029699-00) 06/98 → JD5164  (31-029032-00)	JM5155 [17] (50-029587-00)	JE5025 (31-028750-00)	HR809   (50-319363-00) HR808   (50-319362-00)	NA NC048 (x2) 37.2x52.35x6mm, FPM (50-319368-00) NA NA5137  32.9x47.4x5mm, FPM (50-319367-00) LK LK5004  [3] 80x182x19.4mm, PTFE (50-307318-70)			 AB5130  JN950  AD5130, AD5140, AD5150, AD5160, AD5170  HC440  BJ440  JE5025  BN470  JJ348  BW630  JJ531  BY660  JC724  JC790  JC829  JD188  JD264  JD265  JD498  JD5164  JD5230  JD5290  JE5021  JE719  JM5155  JN332
HBS359  [22-15018B] M11x1.50x150mm (x10)	HA5029   [24-35042-80/0] JD5829  (31-030265-00)	JM5299			NA NA5258 27x47x7mm NA NA5259  40x55x6.4mm		HL5033 [245] 	
HBS001  [22-18083B] M10x1.50x135mm (x10)	JD498  (31-024472-10) JD5746   (31-025159-10) JC829  (31-025656-10) →01/86 JC790  (31-024473-20) 02/86 →  JE719	JN332 (31-024964-10)	HC440  [23-24480-00/0] →12/85 JJ348 (50-025409-10) 01/86 →	HR631  [24-30612-25/0] HR661  [1] (50-306802-50)	NA NA5190 42x56x7mm, FPM (50-307352-70) NB NB645  35x50x7mm, MVQ NB NB847  88x108x11mm, FPM (50-307171-70)	NB596 [2]  NB655 [2]  NA579 [2] 		
HBS001  [22-18083B] M10x1.50x135mm (x10)	JD188   (31-027056-00) JC724   (31-027055-00) JC829  (31-025656-10)	JN332 (31-024964-10)	JJ348 (50-025409-10)	HR661  [1] (50-306802-50)	NA NA5190  42x56x7mm, FPM (50-307352-70) NB NB645  35x50x7mm, MVQ NB NB847  88x108x11mm, FPM (50-307171-70)			
HBS001  [22-18083B] M10x1.50x135mm (x10)	JD188   (31-027056-00) JC724   (31-027055-00) JC829  (31-025656-10)	JN332 (31-024964-10)	JJ348 (50-025409-10)	HR631  [24-30612-25/0] HR661  [1] (50-306802-50)	NA NA5190  42x56x7mm, FPM (50-307352-70) NB NB645  35x50x7mm, MVQ NB NB847  88x108x11mm, FPM (50-307171-70)			
HBS001  [22-18083B] M10x1.50x135mm (x10)	JD498  (31-024472-10) JC790  (31-024473-20)  JE719	JN332 (31-024964-10)	JJ348 (50-025409-10)	HR631  [24-30612-25/0] HR661  [1] (50-306802-50)	NA NA5190  42x56x7mm, FPM (50-307352-70) NB NB645  35x50x7mm, MVQ NB NB847  88x108x11mm, FPM (50-307171-70)	NB596 [2]  NB655 [2] 		
HBS001  [22-18083B] M10x1.50x135mm (x10)	JD188   (31-027056-00) JC724   (31-027055-00) JC829  (31-025656-10)	JN332 (31-024964-10)	JJ348 (50-025409-10)	HR661  [1] (50-306802-50)	NA NA5190  42x56x7mm, FPM (50-307352-70) NB NB645  35x50x7mm, MVQ NB NB847  88x108x11mm, FPM (50-307171-70)			
HBS031  [22-18008B] M10x1.50x102mm (x10)	JD265  (31-028392-00) JD264   (31-028430-00) JE5021  (31-028435-00)	JN950 (50-028423-00)	JJ531 (50-028450-00)	HR5033  [24-30715-70/0]	NB NB958  (x2) 42x53x7mm, FPM (50-319323-00) NB NB959  35x50x7mm, FPM (50-306644-50) NB NB847  88x108x11mm, FPM (50-307171-70)			











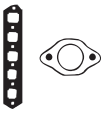

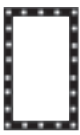

































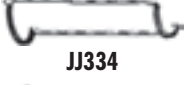













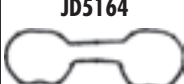



















FORD



KW/PS



Fiesta 1.6L 16V Sport		02/00 → 01/02		73		AC5860 (MLS), 1.25mm (30-029526-00)	CC5860 (21-29526-20/0)	EY650 (22-28750-00/0)
LIT/LIV	1596	4	79.00	Injection	76/103			
Fiesta 1.6L 16V		11/01 →		74		AC5860 (MLS), 1.25mm (30-029526-00) → 11/02 AG9560 (MLS) (30-030341-00) 10/03 →		EB5120
FYJA	1596	4	79.00	Injection, DOHC	74/100			
FYJB	1597	4	76.00	Injection, DOHC	74/100			
Fiesta 1.6L D Diesel		04/84 → 02/89		75		BM950 (Fibre), 1.36mm, 2 Holes (30-024950-10) BM960 (Fibre), 1.42mm, 3 Holes (30-024951-10) BM980 (Fibre), 1.52mm, 4 Holes (30-026287-10)	DM940▲ (21-24949-21/0)	EM940
LTB	1608	4	80.00	SOHC	40/54			
Fiesta 1.6L TDCi Diesel		11/04 →		76		AD5130 (MLS), 1.25mm, 2 Notches, +3 Notches (30-029277-00) AD5140 (MLS), 1.30mm, 3 Notches, +3 Notches (30-029278-00) AD5150 (MLS), 1.35mm, 1 Notch, +3 Notches (30-029279-00) AD5160 (MLS), 1.40mm, +3 Notches, 4 Notches (30-029280-00) AD5170 (MLS), 1.45mm, +3 Notches, 5 Notches (30-029281-00)	CD5140▲ (21-29278-00/0)	
HHJA/HHJB	1560	4	75.00	TDCi, DOHC	66/89			
Fiesta 1.8L 16V		02/92 → 12/95		77		BW640 (Fibre) (30-028040-00)	DW640	EW630 (22-28450-00/0)
Fiesta 1.8L XR2i 16V		02/92 → 12/95						
RDB	1796	4	80.60	Injection, DOHC	77/105			
RQC	1796	4	80.60	Injection, DOHC	96/131			

								
HBS078  (22-18086B) M10x1.50x143mm (x10)	JD5290  (50-029699-00) JD5164  (31-029032-00)	JM5155 [17] (50-029587-00)	JE5025 (31-028750-00)	HR809  (50-319363-00) HR808  (50-319362-00)	NC048 (x2) 37.2x52.35x6mm, FPM (50-319368-00) NA5137  32.9x47.4x5mm, FPM (50-319367-00) LK5004  [3] 80x182x19.4mm, PTFE (50-307318-70)			 AC5860  JM5155  AD5130, AD5140, AD5150, AD5160, AD5170  JN950  BM950, BM960, BM980  JE5025  BW640  JC565  JD264  JD265  JD5164  JD5290  JD5311  JE5021  JE5022  HL474
HBS078  (22-18086B) M10x1.50x143mm (x10)	JD5866  (50-030340-00) (x4) JD5865  (31-030338-00) 11/03 →	JM5155 [17] (50-029587-00)		HR809  (50-319363-00) HR808  (50-319362-00)	NC048 (x2) 37.2x52.35x6mm, FPM (50-319368-00) NA5137  32.9x47.4x5mm, FPM (50-319367-00) LK5004  [3] 80x182x19.4mm, PTFE (50-307318-70)			 BM950, BM960, BM980  JJ334  JJ531
HBS007  (22-18085B)	JC565  (31-025104-10) JE5022  (31-025105-10)	HL474  (24-24961-00/0)	JJ334 (50-024962-00)	HR659  (24-30591-25/0)	NB785 28x38x7mm, FPM (50-305940-50) NB786  42x58x11mm, FPM (50-305941-50) NB788  79.4x95.3x11.1mm, PTFE (50-306413-50)	NB596 [2]  NB655 [2]  NA585 [2] 		 JC565  JD264  JD265  JD5164  JD5290  JD5311  JE5021  JE5022
HBS359  (22-15018B) M11x1.50x150mm (x10)	JD5830  (50-030266-00) HA5031   (24-35043-00/0) HA5030   (24-35042-90/0) JD5829  (31-030265-00)	JM7034 (50-030264-00)			NA5258 27x47x7mm NA5259  40x55x6.4mm	HL5033 [245] 		 JD5164  JD5290  JD5311  JE5021  JE5022
HBS031  (22-18008B) M10x1.50x102mm (x10)	JD265  (31-028392-00) →07/95 JD264  (31-028430-00) JD5311  (50-029872-00) (x4) 08/95 → JE5021  (31-028435-00)	JN950 (50-028423-00)	JJ531 (50-028450-00)	HR5033  (24-30715-70/0)	NB958 (x2) 42x53x7mm, FPM (50-319323-00) NB959  35x50x7mm, FPM (50-306644-50) NB847  88x108x11mm, FPM (50-307171-70)			 JE5021  JE5022  HL474





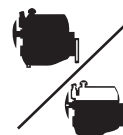

KW/PS

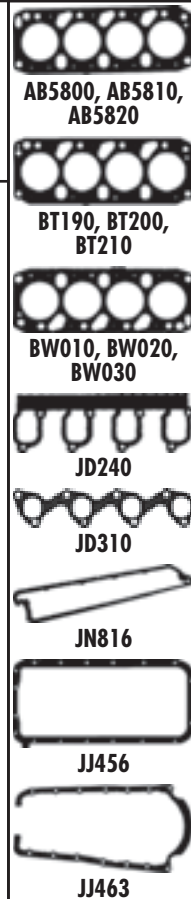
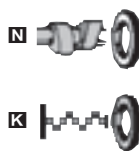
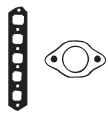

Fiesta 1.8L D Diesel		03/89 → 12/95		78					
Fiesta Van 1.8L D Diesel		03/89 → 02/96							
RTC/RTD/RTG	1753	4	82.50	Indirect Injection	44/60	BT190 (Fibre), 1.36mm, 2 Teeth [4] (30-026353-10) →09/92 ☞0.43→0.68mm BT200 (Fibre), 1.42mm, 3 Teeth [4] (30-026354-10) →08/92 ☞0.681→0.74mm BT210 (Fibre), 1.52mm, 4 Teeth [4] (30-026355-10) →08/92 ☞0.741→0.86mm BW010 (Fibre), 1.36mm, 2 Notches (30-027536-00) 09/92→ ☞0.43→0.68mm AB5800 (Fibre), 1.36mm, 2 Teeth [4] (30-027530-00) 09/92→ ☞0.43→0.68mm BW020 (Fibre), 1.42mm, 3 Notches (30-027537-00) 09/92→ ☞0.681→0.74mm AB5810 (Fibre), 1.42mm, 3 Teeth [4] (30-027531-00) 09/92→ ☞0.681→0.74mm BW030 (Fibre), 1.52mm, 4 Notches (30-027538-00) 09/92→ ☞0.741→0.86mm AB5820 (Fibre), 1.52mm, 4 Teeth [4] (30-027532-00) 09/92→ ☞0.741→0.86mm	DT193▲ (21-26448-21/0)	ET190 [27] (22-26449-00/0) →11/93 ET191 [6] (22-28438-00/0) →11/93 ET192 11/93→	
Fiesta 1.8L D Diesel		08/95 → 04/00		79					
Fiesta Van 1.8L D Diesel		02/96 →							
RTJ/RTK	1753	4	82.50	Indirect Injection	44/60	BW010 (Fibre), 1.36mm, 2 Notches (30-027536-00) ☞0.43→0.68mm AB5800 (Fibre), 1.36mm, 2 Teeth [4] (30-027530-00) ☞0.43→0.68mm BW020 (Fibre), 1.42mm, 3 Notches (30-027537-00) ☞0.681→0.74mm AB5810 (Fibre), 1.42mm, 3 Teeth [4] (30-027531-00) ☞0.681→0.74mm BW030 (Fibre), 1.52mm, 4 Notches (30-027538-00) ☞0.741→0.86mm AB5820 (Fibre), 1.52mm, 4 Teeth [4] (30-027532-00) ☞0.741→0.86mm	DT193▲ (21-26448-21/0)	ET192	









HBS007 
 (22-18085B)
 →08/92
HBS033 
 (22-18007B)
 M12x1.75x136mm (x10)
 09/92→





JD240 
 (31-026450-00)
JD310 
 (31-026847-00)

JN816
 (50-026448-10)



JJ456 [6]
 (50-026449-00)
JJ463 [5]
 (50-028438-00)

HR659 
 (24-30591-25/0)
 →08/92
HR801 
 09/92→

NB785  28x38x7mm, FPM
 (50-305940-50)
NB984  66.67x89.3x10mm, FPM
 (50-306841-50)
NA793  79x95.3x11.1mm, MVQ
NC086  [3] 79.8x184x18.8mm,
 PTFE
 (50-319517-00)

HL5018 [245] 
NB596 [2] 
NA585 [2] 
NJ004 [2] 
NC044 [15]





HBS033 
 (22-18007B)
 M12x1.75x136mm (x10)

JD240 
 (31-026450-00)
JD310 
 (31-026847-00)

JN816
 (50-026448-10)

JJ463
 (50-028438-00)

HR801 

NB785  28x38x7mm, FPM
 (50-305940-50)
NB984  66.67x89.3x10mm, FPM
 (50-306841-50)
NA793  79x95.3x11.1mm, MVQ
NC086  [3] 79.8x184x18.8mm,
 PTFE
 (50-319517-00)

HL5018 [245] 
NC044 [15]











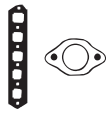

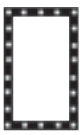

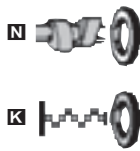



















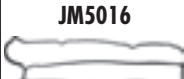



















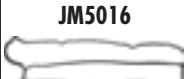



















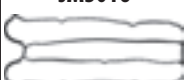
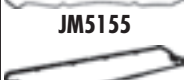







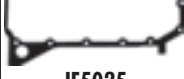







FORD



KW/PS



Fiesta 1.8L DI Diesel		04/00 → 01/02		80		AB5300 (MLS), 1.27mm, 2 Teeth (30-029242-00)		DZ720▲ (21-29180-20/0)		EZ720 (22-29485-00/0)		
Fiesta Van 1.8L DI Diesel		09/00 →				AB5310 (MLS), 1.32mm, 3 Teeth (30-029243-00)						
Fiesta Van 1.8L TD Diesel		03/00 →				AB5320 (MLS), 1.37mm, 4 Teeth (30-029244-00)						
RTN/RTP/RTQ		1753	4	82.50	Direct Injection	55/75	AB5330 (MLS), 1.42mm, 5 Teeth (30-029245-00)					
							AB5340 (MLS), 1.47mm, 6 Teeth (30-029246-00)					
							AB5350 (MLS), 1.52mm, 7 Teeth (30-029247-00)					
Fiesta 1.8L TD Diesel		03/93 → 12/95		81		BW010 (Fibre), 1.36mm, 2 Notches (30-027536-00)		DT193▲ (21-26448-21/0)		ET192		
D18T		1753	4	82.50		57/77	-0.43 → 0.68mm AB5800 (Fibre), 1.36mm, 2 Teeth [4] (30-027530-00)					
							-0.43 → 0.68mm BW020 (Fibre), 1.42mm, 3 Notches (30-027537-00)					
							-0.681 → 0.74mm AB5810 (Fibre), 1.42mm, 3 Teeth [4] (30-027531-00)					
							-0.681 → 0.74mm BW030 (Fibre), 1.52mm, 4 Notches (30-027538-00)					
							-0.741 → 0.86mm AB5820 (Fibre), 1.52mm, 4 Teeth [4] (30-027532-00)					
							-0.741 → 0.86mm					
Fiesta ST150		03/05 →		82		AD5220 (MLS) (30-029824-00)		CD5220 [16] (21-29824-20/0)				
N4JB		1999	4	87.50	Injection, DOHC	110/150			CD5221 [17] (21-29824-21/0)			
Focus 1.25		08/04 →		83		AG8310 (Steel) (30-030170-00)		CB5120 (21-29248-00/0)		EB5120		
FUJA/FUJB		1242	4	71.90	Injection, DOHC	55/75						
Focus 1.4L		11/04 →		84								
ASDA/ASDB		1388	4	76.00	SPi, DOHC	59/80						
Focus 1.4L 16V		10/98 → 11/04		85		AB5130 (MLS) (30-029249-00)		CB5130 [17] (21-28820-30/0)		EY650 (22-28750-00/0)		
FXDA/FXDB/FXDC/FXDD		1388	4	76.00	Injection, DOHC	55/75						
Focus Cabriolet 1.6L Mk II		10/06 →		86		AG9560 (MLS) (30-030341-00)		CG9560 (21-30341-00/0)		EB5120		
Focus 1.6L		11/04 →										
Focus 1.6L C-Max		10/03 → 03/07										
SHDA		1596	4		Injection, DOHC	74/101						
HWDA/HWDB		1596	4	79.00	Injection, DOHC	74/100						

								
HBS243  (22-18089B) M12x1.75x137mm (x2) M12x1.75x177mm (x8)	JD309  (31-026846-00) JD310  (31-026847-00)	JM5016 (50-029180-00)	JH5008 (50-029485-00)	HR801 	NA NB785 28x38x7mm, FPM (50-305940-50) NA NA5013  30x50x7.5mm, PTFE (50-319466-00) NC NC086  [3] 79.8x184x18.8mm, PTFE (50-319517-00)		 AB5130  AB5300, AB5310, AB5320, AB5330, AB5340, AB5350  AB5800, AB5810, AB5820  AD5220  BW010, BW020, BW030  JD309  JD310  JD5164  JD5290  JD5299  JE5037  JM5016  JM5155  JN816  JE5025  JE5025  JJ456	
HBS033  (22-18007B) M12x1.75x136mm (x10)	JD309  (31-026846-00) JD310  (31-026847-00)	JN816 (50-026448-10)	JJ456 (50-026449-00)	HR801 	NA NB785 28x38x7mm, FPM (50-305940-50) NA NB984  66.67x89.3x10mm, FPM (50-306841-50) NA NA793  79x95.3x11.1mm, MVQ NC NC086  [3] 79.8x184x18.8mm, PTFE (50-319517-00)	HL5018 [245]  NC044 [15]	 BW010, BW020, BW030  JD309  JD310  JD5164  JD5290  JD5299  JE5037  JM5016  JM5155  JN816  JE5025  JE5025  JJ456	
HBS369  (22-18095B) M10x1.50x145.5mm (x10)	JD5299  (x4) (50-029584-00) JE5037  [18] (31-029578-10)	JM5153 [17] (50-029582-00) JM5158 [16] (50-029577-00)		HR5063  (24-31945-10/0)	NA NA5157  37x50x8mm, PTFE (50-319442-00) LK LK5005  [3] 88x188x15mm, PTFE (50-319441-00)		 JE5037  JM5016  JM5155  JN816  JE5025  JE5025  JJ456	
HBS078  (22-18086B) M10x1.50x143mm (x10)	JD5866  (50-030340-00)						 JM5155  JN816  JE5025  JE5025  JJ456	
HBS078  (22-18086B) M10x1.50x143mm (x10)	JD5866  (50-030340-00) JD5865  (31-030338-00)	JM5155 [17] (50-029587-00)					 JN816  JE5025  JE5025  JJ456	
HBS078  (22-18086B) M10x1.50x143mm (x10)	JD5290  (x2) (50-029699-00) JD5164  (31-029032-00)	JM5155 [17] (50-029587-00)	JE5025 (31-028750-00)	HR809   (50-319363-00) HR808   (50-319362-00)	NC NC048 (x2) 37.2x52.35x6mm, FPM (50-319368-00) NA NA5137  32.9x47.4x5mm, FPM (50-319367-00) LK LK5004  [3] 80x182x19.4mm, PTFE (50-307318-70)		 JE5025  JE5025  JJ456	
HBS078  (22-18086B) M10x1.50x143mm (x10)	JD5866  (50-030340-00) JD5865  (31-030338-00)	JM5155 [17] (50-029587-00)					 JJ456	







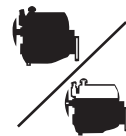



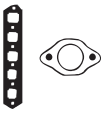

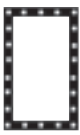

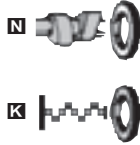

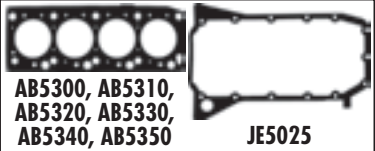







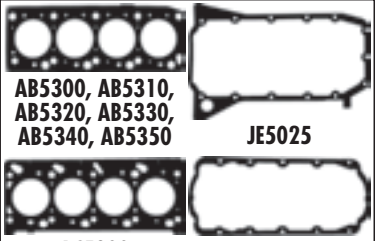









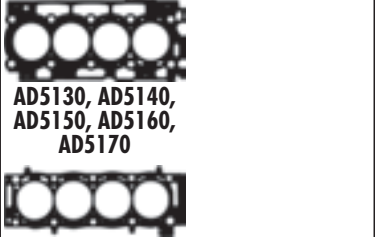

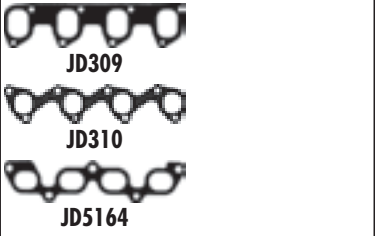







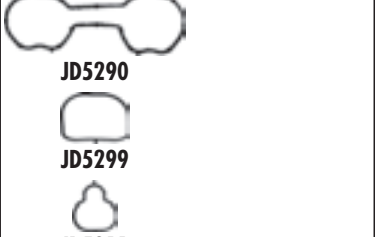





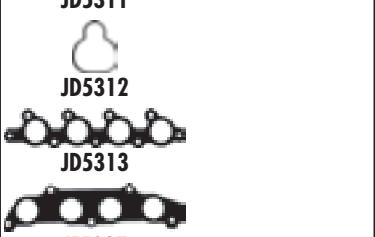

FORD

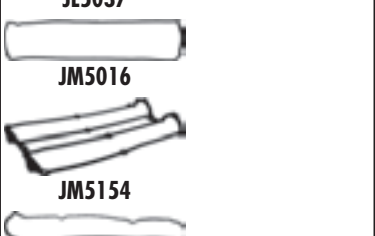

KW/PS

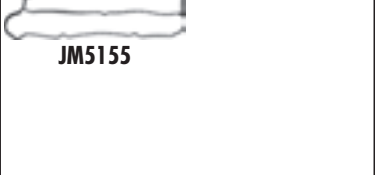

Focus 1.6L 16V					02/99 → 11/04	87	AC5860 (MLS), 1.25mm (30-029526-00)	CC5860 (21-29526-20/0)	EY650 (22-28750-00/0)
FYDA/FYDB/FYDC/ FYDD/FYDH	1596	4	79.00	Injection, DOHC	74/100				
Focus 1.6L TDCi Diesel					11/04 →	88	AD5130 (MLS), 1.25mm, 2 Notches, +3 Notches (30-029277-00)	CD5140▲ (21-29278-00/0)	ED5130
Focus C-MAX 1.6L TDCi Diesel					10/03 → 03/07				
HHDA/HHDB	1560	4	75.00	TDCi, DV6	66/89	AD5140 (MLS), 1.30mm, 3 Notches, +3 Notches (30-029278-00)			
HHJA, HHJB	1560	4	75.00		66/89	AD5150 (MLS), 1.35mm, 1 Notch, +3 Notches (30-029279-00)			
G8DA	1560	4	75.00	TDCi, DOHC	80/109	AD5160 (MLS), 1.40mm, +3 Notches, 4 Notches (30-029280-00)			
G8DA, G8DB	1560	4	75.00		80/109	AD5170 (MLS), 1.45mm, +3 Notches, 5 Notches (30-029281-00)			
G8DB	1560	4	75.00	TDCi, DOHC	80/109				
Focus 1.6L Ti					11/04 →	89			
Focus 1.6L Ti C-Max					08/04 → 03/07				
HXDA	1596	4	79.00	Injection, DOHC	85/115				
Focus 1.8L 16V					02/99 → 11/04	90	AC5800 (MLS) (30-029400-00)	CC5800 (21-29400-20/0) → 04/99	EC5800 (22-29400-00/0)
EYDB/EYDC/EYDD/ EYDE/EYDF	1796	4	80.60	DOHC	85/115				
EYDG/EYDI/EYDJ/EYDL	1796	4	80.60	Injection, DOHC	85/115			CC5801 (21-29400-21/0) 09/99 →	
Focus 1.8L C-Max					04/04 → 03/07	91	AC5940 (MLS) (30-029554-00)	DW643 (21-29554-21/0)	ED5220 (22-29824-00/0)
Focus 1.8L Flexifuel					01/06 →				
Focus 1.8L Flexifuel C-Max					01/06 → 03/07				
Q7DA/QQDA/QQDB	1798	4	83.00	Injection, DOHC	92/125				
Focus 1.8L DI / TDDi Diesel					08/99 → 11/04	92	AB5300 (MLS), 1.27mm, 2 Teeth (30-029242-00)	DZ720▲ (21-29180-20/0)	EZ720 (22-29485-00/0)
Focus 1.8L TD / TDDi Diesel					10/98 → 11/04				
Focus 1.8L TDCi Diesel					03/01 → 11/04				
BHDA/BHDB	1753	4	82.50	Direct injection, SOHC	55/66/ 75	AB5310 (MLS), 1.32mm, 3 Teeth (30-029243-00)			
C9DA/C9DB/C9DC	1753	4	82.50	Direct injection, SOHC	55/66/ 90	AB5320 (MLS), 1.37mm, 4 Teeth (30-029244-00)			
F9DA/F9DB/FFDA	1753	4	82.50	Common Rail	66/74/ 85/90/ 101/ 116	AB5330 (MLS), 1.42mm, 5 Teeth (30-029245-00)			
						AB5340 (MLS), 1.47mm, 6 Teeth (30-029246-00)			
						AB5350 (MLS), 1.52mm, 7 Teeth (30-029247-00)			
Focus 1.8L TDCi Diesel					11/04 → 03/07	93			
KKDA	1753	4	82.50	Direct Injection, DOHC	85/115				
Focus Cabriolet 2.0L TDCi Mk II Diesel					10/06 →	94	AD5490 (MLS), 1.25mm (30-029789-00)	CD5500▲	ED5500
Focus 2.0L TDCi Diesel					10/03 → 03/07				
G6DA/G6DB	1997	4	85.00	Direct Injection, DOHC	100/136	AD5500 (MLS), 1.30mm (30-029790-00)			
G6DD	1997	4	85.00	TDCi, DOHC	100/136	AD5510 (MLS), 1.35mm (30-029791-00)			
						AD5520 (MLS), 1.40mm (30-029792-00)			

								
HBS078  (22-18086B) M10x1.50x143mm (x10)	JD5290  (x2) (50-029899-00) JD5164  (31-029032-00) →11/03 JD5865  (31-030338-00) 11/03→	JM5155 [17] (50-029587-00)	JE5025 (31-028750-00)	HR809  (50-319363-00) HR808  (50-319362-00)	NA NC048 (x2) 37.2x52.35x6mm, FPM (50-319368-00) NA NA5137  32.9x47.4x5mm, FPM (50-319367-00) LK LK5004  [3] 80x182x19.4mm, PTFE (50-307318-70)			 AB5300, AB5310, AB5320, AB5330, AB5340, AB5350 JE5025 AC5800 JH5061 AC5860 AC5940 AD5130, AD5140, AD5150, AD5160, AD5170 AD5490, AD5500, AD5510, AD5520
HBS359  (22-15018B) M11x1.50x150mm (x10)	JD5830   (50-030266-00) HA5031   (24-35043-00/0) HA5030   (24-35042-90/0) JD5829  (31-030265-00)	JM7034 (50-030264-00)			NA NA5258 27x47x7mm NA NA5259  40x55x6.4mm		HL5033 [245]	
HBS078  (22-18086B) M10x1.50x143mm (x10)	JD5865  (31-030338-00)	JM5155 [17] (50-029587-00)						
HBS031  (22-18008B) M10x1.50x102mm (x10)	JD5311  (x4) (50-029872-00) →09/99 JD5312  (x4) (50-029873-00) 09/99→ JD5313  (50-029874-00)	JM5154 (50-029581-00) →04/99 JM5184 (50-029871-00) Light Blue 04/99→	JH5061 (50-029586-00)	HR5033  (24-30715-70/0)	NA NB958  (x2) 42x53x7mm, FPM (50-319323-00) NA NB959  35x50x7mm, FPM (50-306644-50) NA NB847  88x108x11mm, FPM (50-307171-70)			
HBS369  (22-18095B) M10x1.50x145.5mm (x10)	JD5299  (50-029584-00) JE5037  [18] (31-029578-10)	JM5153 (50-029582-00)		HR5063  (24-31945-10/0)	NA NA5157  37x50x8mm, PTFE (50-319442-00) LK LK5005  [3] 88x188x15mm, PTFE (50-319441-00)			
HBS243  (22-18089B) M12x1.75x137mm (x2) M12x1.75x177mm (x8)	JD309  (31-026846-00) JD310  (31-026847-00)	JM5016 (50-029180-00)	JH5008 (50-029485-00)	HR801 	NA NB785 28x38x7mm, FPM (50-305940-50) NA NA5013  30x50x7.5mm, PTFE (50-319466-00) NA NC086  [3] 79.8x184x18.8mm, PTFE (50-319517-00)			
HBS243  (22-18089B) M12x1.75x137mm (x2) M12x1.75x177mm (x8)								
HBS368 (22-18094B)	JD5881 	HM5289 			NA NA5035 27x47x7mm, FPM (50-319474-00) NA NA5191  42x62x7mm, PTFE (50-319500-00) NA NA5192  90x110x7mm, PTFE (50-319501-00)			







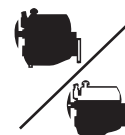



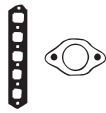

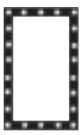

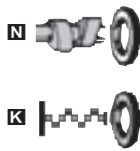





























































FORD



KW/PS



Focus 2.0L						11/04 →	95	AD5220 (MLS)		CD5221	ED5220
Focus 2.0L C-Max						04/04 → 03/07		[30-029824-00]		[21-29824-21/0]	[22-29824-00/0]
AODA/AODB	1999	4	87.50	Injection, DOHC		107/145					
Focus 2.0L 16V						10/98 → 11/04	96	BZ490 (MLS)		DZ490	EC5800
EDDD	1988	4	84.80	Injection, DOHC		96/131	[30-027876-10]		[21-27876-20/0]	[22-29400-00/0]	
EDDB/EDDC/EDDF	1988	4	84.80	DOHC		96/100/ 131/ 136	→01/99 AB5260 (MLS) [30-028827-00] 01/99 → 04/03 AE5320 (MLS) [30-029870-00] 05/03 →		→01/99 CE5320 [21-29870-20/0] 01/99 →		
Focus 2.0L RS						10/02 → 11/04	97				
HMDA	1988	4	84.80	Injection, DOHC		158/215					
Focus ST170						03/02 → 11/04	98	AB5260 (MLS)			
ALDA	1988	4	84.80	Injection, DOHC		127/172	[30-028827-00] →04/03 AE5320 (MLS) [30-029870-00] 05/03 →				
Focus 2.5L ST						10/05 →	99	AG8320 (MLS)			
HYDA	2522	5	83.00	Injection, DOHC			[30-029272-00]				
Fusion 1.4L						08/02 →	100	AB5130 (MLS)		CB5132	EB5120
FXJA/FXJB	1388	4	76.00	SPi, DOHC		59/80	[30-029249-00]		[21-29249-10/0]		
Fusion 1.4L TDCi Diesel						08/02 →	101	AD5130 (MLS), 1.25mm, 2 Notches, +3 Notches		CD5130▲	ED5130
F6JA / DV4TD/F6JB	1398	4	73.70	Common Rail, SOHC		50/68	[30-029277-00] AD5140 (MLS), 1.30mm, 3 Notches, +3 Notches [30-029278-00] AD5150 (MLS), 1.35mm, 1 Notch, +3 Notches [30-029279-00] AD5160 (MLS), 1.40mm, +3 Notches, 4 Notches [30-029280-00] AD5170 (MLS), 1.45mm, +3 Notches, 5 Notches [30-029281-00]		[21-29277-00/0]		
Fusion 1.6L						08/02 →	102	AC5860 (MLS), 1.25mm			EB5120
FYJA	1596	4	79.00	Injection, DOHC		74/100	[30-029526-00]				
FYJB	1597	4	76.00	Injection, DOHC		74/100	→11/02 AG9560 (MLS) [30-030341-00] 10/03 →				
Fusion 1.6L TDCi Diesel						11/04 →	103	AD5130 (MLS), 1.25mm, 2 Notches, +3 Notches		CD5140▲	
HHJA/HHJB	1560	4	75.00	TDCi, DOHC		66/89	[30-029277-00] AD5140 (MLS), 1.30mm, 3 Notches, +3 Notches [30-029278-00] AD5150 (MLS), 1.35mm, 1 Notch, +3 Notches [30-029279-00] AD5160 (MLS), 1.40mm, +3 Notches, 4 Notches [30-029280-00] AD5170 (MLS), 1.45mm, +3 Notches, 5 Notches [30-029281-00]		[21-29278-00/0]		







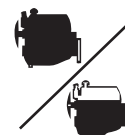



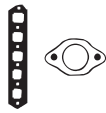

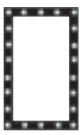

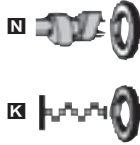







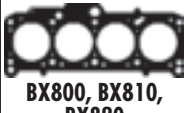

































								
HBS369  (22-18095B) M10x1.50x145.5mm (x10)	JD5299  (x4) (50-029584-00) JE5037  [18] (31-029578-10)	JM5153 (50-029582-00)		HR5063  (24-31945-10/0)	NA5157  37x50x8mm, PTFE (50-319442-00) LK5005  [3] 88x188x15mm, PTFE (50-319441-00)			 AB5130  AB5260  AC5860  AD5130, AD5140, AD5150, AD5160, AD5170  AD5220  AE5320  BZ490  JD5164  JD5299  JD5311  JD5312  JD5313  JE5037  JM5154  JM5155  JH5061
HBS031  (22-18008B) M10x1.50x102mm (x10)	JD5311  (x4) (50-029872-00) →08/99 JD5312  (x4) (50-029873-00) 01/98 → JD5313  (50-029874-00)	JM5154 (50-029581-00) →04/99 JM5184 (50-029871-00) Light Blue 04/99 →	JH5061 (50-029586-00)	HR5033  (24-30715-70/0)	NB958  (x2) 42x53x7mm, FPM (50-319323-00) NB959  35x50x7mm, FPM (50-306644-50) NB847  88x108x11mm, FPM (50-307171-70)			
HBS031  (22-18008B) M10x1.50x102mm (x10)								
HBS031  (22-18008B) M10x1.50x102mm (x10)	JD5311  (x4) (50-029872-00) JD5313  (50-029874-00)		JH5061 (50-029586-00)	HR5063  (24-31945-10/0)	NB958  42x53x7mm, FPM (50-319323-00) NB959  35x50x7mm, FPM (50-306644-50) NB847  88x108x11mm, FPM (50-307171-70)			
HBS185  (22-53012B) M12x1.75x157mm (x12)								
HBS078  (22-18086B) M10x1.50x143mm (x10)	JD5866  (50-030340-00) JD5164  (31-029032-00) →10/03	JM5155 [17] (50-029587-00)		HR809  (50-319363-00) HR808  (50-319362-00)	NC048 (x2) 37.2x52.35x6mm, FPM (50-319368-00) NA5137  32.9x47.4x5mm, FPM (50-319367-00) LK5004  [3] 80x182x19.4mm, PTFE (50-307318-70)			
HBS359  (22-15018B) M11x1.50x150mm (x10)	HA5029   (24-35042-80/0) JD5829  (31-030265-00)	JM5299			NA5258 27x47x7mm NA5259  40x55x6.4mm		HL5033 [245] 	
HBS078  (22-18086B) M10x1.50x143mm (x10)	JD5866  (x4) (50-030340-00) JD5865  (31-030338-00) 11/03 →	JM5155 [17] (50-029587-00)		HR809  (50-319363-00) HR808  (50-319362-00)	NC048 (x2) 37.2x52.35x6mm, FPM (50-319368-00) NA5137  32.9x47.4x5mm, FPM (50-319367-00) LK5004  [3] 80x182x19.4mm, PTFE (50-307318-70)			
HBS359  (22-15018B) M11x1.50x150mm (x10)	JD5830   (50-030266-00) HA5031    (24-35043-00/0) HA5030    (24-35042-90/0) JD5829  (31-030265-00)	JM7034 (50-030264-00)			NA5258 27x47x7mm NA5259  40x55x6.4mm		HL5033 [245] 	



KW/PS



Galaxy 1.9L TDI Diesel				04/00 →		104	AF5381 (MLS), 1,49mm, 1 Hole 30-030098-10	CC5230▲ 21-29463-21/0
AUY	1896	4	79.50	Direct Injection, SOHC	85/116	30-030098-10		
ASZ	1896	4	79.50	Direct Injection, SOHC	96/131	AF5391 (MLS), 1,57mm, 2 Holes 30-030099-10		
BTB	1896	4	79.50	TDi, SOHC	110/150	AF5401 (MLS), 1,65mm, 3 Holes 30-030100-10		
Galaxy 1.9L TDI Diesel				03/95 →		105	BX800 (MLS), 1.45mm, 1 Hole 30-028686-00	DX800▲ 21-27921-20/0
AHU	1896	4	79.50	Direct Injection, SOHC	66/89	30-028686-00	EA801 [8]	
ANU	1896	4	79.50		66/89	BX810 (MLS), 1.53mm, 2 Holes 30-028687-00		
IZ	1896	4	79.50		66/90	BX820 (MLS), 1.61mm, 3 Holes 30-028688-00		
Galaxy 1.9L TDI Diesel				08/97 → 04/00		106	BX800 (MLS), 1.45mm, 1 Hole 30-028686-00	DX800▲ 21-27921-20/0
AFN	1896	4	79.50	SOHC	81/110	30-028686-00	EA801 [8] EC030 [8] 22-26384-04/0 AFN Only	
AVG	1896	4	79.50	Direct Injection, SOHC	81/110	BX810 (MLS), 1.53mm, 2 Holes 30-028687-00 BX820 (MLS), 1.61mm, 3 Holes 30-028688-00		
Galaxy 2.0L TDCi Diesel				05/06 →		107	AD5490 (MLS), 1.25mm (30-029789-00)	CD5500▲
AZWA/QXWA/QXWB	1997	4	85.00	Direct Injection, DOHC		AD5500 (MLS), 1.30mm (30-029790-00)	ED5500	
						AD5510 (MLS), 1.35mm (30-029791-00)		
						AD5520 (MLS), 1.40mm (30-029792-00)		
Galaxy 2.0L i				11/95 →		108	AC5910 (MLS), 1.60mm (30-029401-00)	EX550 (22-26643-00/0)
NSE/ZVSA	1998	4	86.00	EFI, DOHC	85/116			
Galaxy 2.3L 16V				01/97 →		109	AC5680 (MLS) (30-029402-00)	CC5680
E5SB	2295	4	89.60	DOHC	103/140			
E5SA	2295	4	89.60	DOHC	107/146			
Y5B	2295	4	89.60	SPi, DOHC	107/146			
Galaxy 2.8L i V6				11/95 → 04/00		110	AA5430 (Fibre) 30-027920-00	CA5431■
Galaxy 2.8L i V6 4x4				04/96 → 04/00				
AAA/AMY	2792	6	81.00	Injection, DOHC, V6	128/174			

								
HBS300 ⊕ (22-33034B) M12x1.75x166mm (x10)	JD170 ■ 31-026556-10 JD600 ■ 31-028454-00	JM5203 50-029934-00		HR816 ■ 24-30653-85/0	NA5124 32x47x10mm, PTFE (50-319433-00) NA5106 ■ 35x48x10mm, PTFE (50-319430-00) LK5003 ■ [3] 85x131x15.7mm, PTFE (50-319434-00)			 AA5430  JH5013  AC5680  AC5910  JJ140  JJ457
HBS018 ⊕ (22-39024B) M12x1.75x115mm (x10)	JD170 ■ 31-026556-10 JC152 ■ (x4) 31-026555-00	JP003 50-027921-00	JJ140 (31-026554-10)	HR569 ■ 24-30667-00/0 →Eng.1Z 770 000 HR816 ■ 24-30653-85/0 Eng.1Z 770 001→ AHU, ANU	NA5001 32x47x10mm, FPM (50-303185-50) NA5001 ■ 32x47x10mm, FPM (50-303185-50) 1Z, AHU NA5106 ■ 35x48x10mm, PTFE (50-319430-00) ANU NA5133 ■ 85x105x11mm, FPM (24-30727-87/0) →Eng.AHU 390 000 1Z, AHU LK5003 ■ [3] 85x131x15.7mm, PTFE (50-319434-00) ANU LK5006 ■ [3] 85x131x16mm, PTFE (50-319448-00) Eng.AHU 390 001→			 AD5490, AD5500, AD5510, AD5520  BX800, BX810, BX820  JA5068  JA5069  JC152  JD170  JD5109  JD5232  JD542  JD543  JD600  JM5030  JM5099  JP003
HBS018 ⊕ (22-39024B) M12x1.75x115mm (x10)	JD170 ■ 31-026556-10 JC152 ■ (x4) 31-026555-00	JP003 50-027921-00	JJ140 (31-026554-10)	HR569 ■ 24-30667-00/0 →Eng.AFN 002 000 HR816 ■ 24-30653-85/0 Eng.AFN 002 001→ AVG	NA5001 32x47x10mm, FPM (50-303185-50) NA5001 ■ 32x47x10mm, FPM (50-303185-50) NA5133 ■ 85x105x11mm, FPM (24-30727-87/0)			 JA5069  JC152  JD170  JD5109  JD5232  JD542  JD543  JD600  JM5030  JM5099  JP003
HBS261 ⊕ (22-53014B) M12x1.50x131mm (x10)	JD5881 ■	HM5289 ■						 JD5109  JD5232  JD542  JD543  JD600  JM5030  JM5099  JP003
HBS032 ⊕ (22-18003B) M11x1.50x178mm (x10)	JD542 ■ (x2) (31-026711-00) JD543 ■ (x2) (31-026640-00)		JJ457 (50-026643-00)	HR655 ■ 24-30691-15/0	NB645 ■ 35x50x7mm, MVQ NA5190 ■ 42x56x7mm, FPM (50-307352-70) NB847 ■ 88x108x11mm, FPM (50-307171-70)	NB596 [2]■ NB655 [2]■		 JD542  JD543  JD600  JM5030  JM5099  JP003
HBS032 ⊕ (22-18003B) M11x1.50x178mm (x10)		HM5238 ■		HR655 ■ (x2) 24-30691-15/0	NA5177 ■ 42x56x7mm, FPM (50-319189-00)			 JM5030  JM5099  JP003
HBS077 ⊕ (22-39012B) M11x1.50x85mm (x7) M11x1.50x144mm (x3) M11x1.50x119mm (x10)	JD5232 ■ [28] (31-027918-00) JA5068 ■ [28] (31-027917-00) JA5069 ■ [28] (31-027913-00) JD5109 ■ [29] (31-027914-00)	JM5030 50-027915-00 →Eng.AAA146000 JM5099 50-029103-00 Eng.AAA146001→ AMY	JH5013 (31-027911-00)	HR5030 ■ (24-30676-76/0)	NA5038 ■ 85x105x12mm, FPM NB716 ■ 35x48x10mm, FPM (50-306067-50) NA5133 ■ 85x105x11mm, FPM (24-30727-87/0)			 JM5030  JM5099  JP003











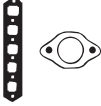

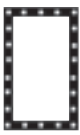



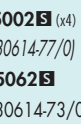
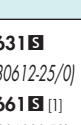
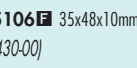

























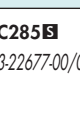
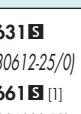
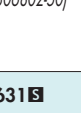
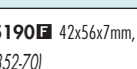
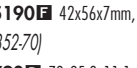
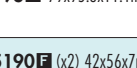















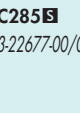
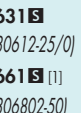

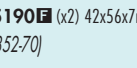
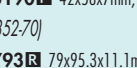
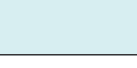















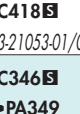
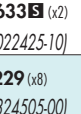
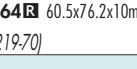





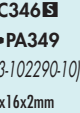
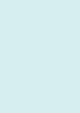
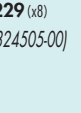
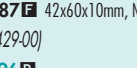
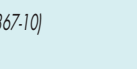





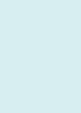
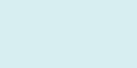
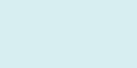















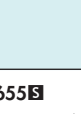
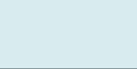
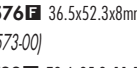









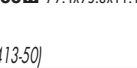
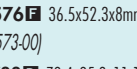

FORD

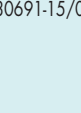
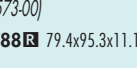

KW/PS

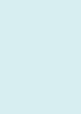
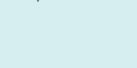
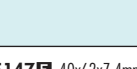

Galaxy 2.8L V6				04/00 →	111	AG5000 (MLS)	CG5030	EG7800
AYL	2792	6	81.00	Injection, DOHC, V6	150/204	(30-030123-00)	21-30123-30/0	
Granada 1.6L				07/81 → 08/85	112	AH850 (Fibre)	CH851	EH850
LCK	1593	4	87.65	SOHC	55/75	(30-022666-20)	(21-22641-20/0) → 08/93 CH854 09/83 →	(22-22677-00/0)
Granada 2.0L				08/79 → 08/85	113	AH860 (Fibre)	CH861	EH850
NEK/NEP	1993	4	90.80	Injection, DOHC	77/105	(30-025148-10)	→ 08/83 CH864 (21-25148-40/0)	(22-22677-00/0)
Granada 2.0L				08/77 → 08/85	114			EL080
NYP	1996	6	93.64	V6	66/89			
Granada 2.5L D Diesel				08/82 → 08/85	115	BP890 (Fibre), 1.53mm, 2 Notches	DH890▲■	GH890▲○
STP (XD3/XD3P)	2498	4	94.00		51/69	(30-026144-10) BP900 (Fibre), 1.63mm, 3 Notches (30-026145-10) BP910 (Fibre), 1.73mm, 4 Notches (30-026146-10)		(20-24586-05/0)
Ka 1.0L i				07/97 → 09/99	116	BT110 (Fibre)		
	999	4	68.70	OHV (HCS)	38/52	(30-026495-00)		
Ka 1.3L i				09/96 →	117	BT140 (Fibre)	DY671■	EY671
JJD	1297	4	73.96	EFI	37/44/ 50/60	(30-026496-00)	(21-26496-21/0)	(22-29632-00/0)
JJF/JJG/JJH/JJL	1299	4	74.00	Injection	36/49			
JJB/Endura E	1299	4	74.00	Injection	37/50			
BAA	1299	4	74.00	Injection, SOHC	44/60			
J4D/Endura	1299	4	74.00	Injection	44/60			
E/J4K/J4M/J4N/J4P/ J4S								
Ka 1.3L i				08/02 →	118	AD5020 (MLS)	CD5020■	EC5890 [12]
A9A, A9B	1299	4	74.00		51/70	(30-029602-00)	(21-26602-20/0)	(22-28811-00/0)
Ka 1.6L i				07/03 →	119	AC5890 (MLS)	CC5890	EC5890 [12]
CDB, CDC	1599	4	82.00		70/95	(30-028811-00)	(21-28811-20/0)	(22-28811-00/0)
Maverick 2.0L 16V				02/01 →	120	AE5320 (MLS)	CE5320	
YF	1988	4	84.80	Injection, DOHC	91/124	(30-029870-00)	(21-29870-20/0)	

								
HBS077  (22-39012B) M11x1.50x85mm (x7) M11x1.50x144mm (x3) M11x1.50x119mm (x10)		JM7045 50-030133-00 (Rubber)		HL5002  (x4) (24-30614-77/0) HR5062  24-30614-73/0	NA5106  35x48x10mm, PTFE (50-319430-00)			 AC5890  AD5020  AE5320  AG5000  AH850, AH860  BP890, BP900, BP910  BT110  BT140  HA497  JA768  JA769  JA770  JC365  JC566  JD5151  JD5312  JD5313  JD545  JE719  JM510
HBS056  (22-18002B) M12x1.75x92.5mm (x10)	JA769  (31-022642-10) JA768  (31-022672-10) JA770  (x3) (31-022671-10)  JE719	JM510 (31-022641-20) →08/83 JN620 (31-024963-40) 09/83→	HC285  (23-22677-00/0)	HR631  (24-30612-25/0) HR661  (11) (50-306802-50)	NA5190  42x56x7mm, FPM (50-307352-70) NA5190  42x56x7mm, FPM (50-307352-70) NA793  79x95.3x11.1mm, MVQ	NA580  [2] NA585  [2] KA289  [13]	 JN105  JN245  JN620  HC285  HC346  JH5015  JH5061	
HBS056  (22-18002B) M12x1.75x92.5mm (x10)	JA769  (31-022642-10) JA768  (31-022672-10) JA770  (x3) (31-022671-10)  JE719	JM510 (31-022641-20) →08/83 JN620 (31-024963-40) 09/83→	HC285  (23-22677-00/0)	HR631  (24-30612-25/0) HR661  (11) (50-306802-50)	NA5190  (x2) 42x56x7mm, FPM (50-307352-70) NA5190  42x56x7mm, FPM (50-307352-70) NA793  79x95.3x11.1mm, MVQ	NA580  [2] NA585  [2] NB655  [2] KA289  [13] KT738  [14]	 JN105  JN245  JN620  HC285  HC346  JH5015  JH5061	
JC365  (x4) (32-206600-10)	JM875  (x2) (31-021055-10)	JM875  (x2) (31-021055-10)	HC418  (23-21053-01/0)	HR633  (x2) (50-022425-10)	NB564  60.5x7.6x10mm, FPM (50-307219-70)	NA580  [2] NA585  [2]		
HBS229  (22-53001B) M11x1.50x97.5mm (x7) M11x1.50x97mm (x1) M11x1.50x120mm (x7) M11x1.50x107.5mm (x7) →09/87 HBS016  (22-53005B) M11x1.50x120mm (x7) M11x1.50x107.5mm (x15) 09/87→	JC566  (x2)	JN245 (50-024586-00)	HC346  PA349  (33-102290-10) 22x16x2mm	PA229  (x8) (50-324505-00)	NF387  42x60x10mm, NBR (50-306429-00) KS696  (31-025367-10)		 JH5015  JH5061	
HBS050  (22-18001B) M11x1.50x120mm (x10)	JD5151  (31-029227-00) JD545  (x4) (31-029228-00)	JN105 (31-027902-00)	JH5015 (50-029632-00)	HR655  24-30691-15/0	NA576  36.5x52.3x8mm, MVQ (50-306573-00) NB788  79.4x95.3x11.1mm, PTFE (50-306413-50)		 JA768  JA769  JA770  JC365  JC566  JD5151  JD5312  JD5313  JD545  JE719	
HBS050  (22-18001B) M11x1.50x120mm (x10)	JD5151  (31-029227-00) JD545  (x4) (31-029228-00) HA497  KK5157 	JN105 (31-027902-00)	JH5015 (50-029632-00)	HR655  24-30691-15/0	NA576  36.5x52.3x8mm, MVQ (50-306573-00) NB788  79.4x95.3x11.1mm, PTFE (50-306413-50)		 JA770  JC365  JC566  JD5151  JD5312  JD5313  JD545  JE719	
HBS358  (22-18093B) M11x1.50x158mm (x10) M8x0.0x45mm (x2)	JD5220  (x2) (50-029604-00) JD5219  (31-029603-00)	JM5104 (50-029605-00)	JH5046 (31-029607-00)	PA5033  (x8) (50-319443-00)	NA5147  40x62x7.4mm, PTFE (50-319446-00) NA5130  [3] 79x196x21.5mm, PTFE (50-319444-00)	KA5021  [13]		
HBS358  (22-18093B) M11x1.50x158mm (x10) M8x0.0x45mm (x2)	JD5227  (31-029609-00) JD5219  (31-029603-00)	JM5104 (50-029605-00)	JH5046 (31-029607-00)	PA5033  (x8) (50-319443-00)	NA5147  40x62x7.4mm, PTFE (50-319446-00) NA5130  [3] 79x196x21.5mm, PTFE (50-319444-00)	KA5021  [13]		
HBS031  (22-18008B) M10x1.50x102mm (x10)	JD5312  (x4) (50-029873-00) JD5313  (50-029874-00)	JM5184 (50-029871-00) Light Blue	JH5061 (50-029586-00)	HR5033  (24-30715-70/0)	NB958  (x2) 42x53x7mm, FPM (50-319323-00) NB959  35x50x7mm, FPM (50-306644-50)			











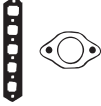

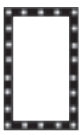

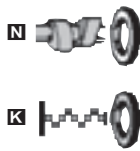







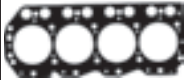





















































FORD



KW/PS



Maverick 2.3L 16V					03/04 →	121	AD5220 (MLS) (30-029824-00)	CD5220 ^[1.6] (21-29824-20/0) CD5221 ^[1.7] (21-29824-21/0)	ED5220 (22-29824-00/0)
GZ	2261	4	87.50	Injection, DOHC					
Maverick 2.4L i					02/93 →04/98	122	BS770 (Graphite) (30-028258-00)	DS771■ (21-28258-21/0)	GS770
KA-24	2389	4	89.00	Injection, SOHC	87/118				
KA24-E	2389	4	89.00	Injection, SOHC	91/124				
Maverick 2.7L TD Diesel					02/93 →04/98	123	AC5750 (MLS), 1.20mm, 1 Notch (30-029544-00) AC5760 (MLS), 1.25mm, 2 Notches (30-029545-00) AC5770 (MLS), 1.30mm, 3 Notches (30-029546-00)	CC5750▲	
TD27/TD27E	2664	4	96.00	SOHC	92/125				
Maverick 3.0L 24V					02/01 →	124	AG7820 (MLS) ☒ AG7810 (MLS) ☒	CG7810	
AJ	2967	6	89.00	Injection, DOHC, V6	149- 145/ 203- 197				
Maverick 3.0L 24V					03/04 →	125	AG7810 (MLS) ☒ AG7820 (MLS) ☒	CG7810	
AJ	2967	6	89.00	Injection, DOHC, V6	149- 145/ 203- 197				
Mondeo 1.6L i					09/96 →11/00	126	BW630 (Fibre) (30-028039-00)	DW631 (21-28423-21/0) →08/98	EW630 (22-28450-00/0)
Mondeo 1.6L i 16V					02/93 →11/00				
L1J	1597	4	76.00	DOHC	65/88				
L1F	1597	4	76.00	DOHC	66/90				
L1L/L1N/L1Q	1597	4	76.00	Injection, DOHC	70/95				
Mondeo 1.8L 16V					11/00 →	127	AC5940 (MLS) (30-029554-00)	DW642 ^[1.6] (21-29554-20/0) DW643 ^[1.7] (21-29554-21/0)	ED5220 (22-29824-00/0)
CGBA/CGBB	1796	4	83.00	SPi, DOHC	81/110				
Mondeo 1.8L i					09/96 →11/00	128	BW640 (Fibre) (30-028040-00) →12/98 AC5800 (MLS) (30-029400-00) 01/99 →	DW641 →08/98	EW630 (22-28450-00/0) →12/98 EC5800 (22-29400-00/0) 12/98 →
RKB	1796	4	80.60	DOHC	82-85/ 113- 128				
RKF/RKH/RKJ/RKK	1796	4	80.60	DOHC	85/115				
Mondeo 1.8L i 16V					02/93 →08/96	129	BW640 (Fibre) (30-028040-00)	DW641	EW630 (22-28450-00/0)
Mondeo 1.8L i 16V 4x4					02/93 →08/96				
RKB	1796	4	80.60	DOHC	82-85/ 113- 128				
RKA	1796	4	80.60	DOHC	85/115				







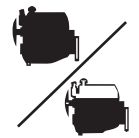



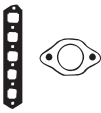

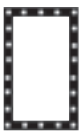

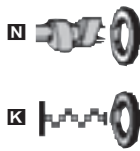













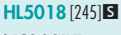
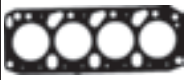















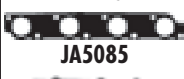















								
HBS369  (22-18095B) M10x1.50x145.5mm (x10)	JD5299  (x4) (50-029584-00) JE5037  [18] (31-029578-10)	JM5153 (50-029582-00)		HR5063  (24-31945-10/0)	NA5157  37x50x8mm, PTFE (50-319442-00) LK5005  [3] 88x188x15mm, PTFE (50-319441-00)			 AC5750, AC5760, AC5770  AC5800  AC5940  AD5220  BS770  BW630, BW640  JC806  JC900  JC901  JD266  JD5299  JD5311  JD5312  JE5021  JE5037  JM5154  JN724  JN743  JN950
HBS432  (22-70015B) M10x1.50x110.0mm (x10)	JC901  JC900  (x2)	JN743 (50-028304-00)		PA933  (x4) PA079  (x8)				
HBS194  (22-70010B) M12x1.50x113mm (x18)	JC805  JC806  (x4)	JN724 (50-028308-00)		PA378 (x8)	NJ831  58x80x10mm, NBR NJ829  86x100x10mm, MVQ			
		JM5294  JM5293 						
		JM5294  JM5293 						
HBS031  (22-18008B) M10x1.50x102mm (x10)	JD266  (31-028378-00) →08/95 JD5311  (x4) (50-029872-00) 08/95→09/99 JD5312  (x4) (50-029873-00) 09/99→ JE5021  (31-028435-00)	JN950 (50-028423-00) →08/98 JM5154 (50-029581-00) 09/98→04/99 JM5184 (50-029871-00) Light Blue 04/99→	JJ531 (50-028450-00)	HR5033  (24-30715-70/0)	NB958  (x2) 42x53x7mm, FPM (50-319323-00) NB959  35x50x7mm, FPM (50-306644-50) NB847  88x108x11mm, FPM (50-307171-70)			
HBS369  (22-18095B) M10x1.50x145.5mm (x10)	JD5299  (50-029584-00) JE5037  [18] (31-029578-10)	JM5153 [17] (50-029582-00) JM5158 [16] (50-029577-00)		HR5063  (24-31945-10/0)	NA5157  37x50x8mm, PTFE (50-319442-00) LK5005  [3] 88x188x15mm, PTFE (50-319441-00)			
HBS031  (22-18008B) M10x1.50x102mm (x10)	JD266  (31-028378-00) →07/95 JD5311  (x4) (50-029872-00) 08/95→08/99 JD5312  (x4) (50-029873-00) 09/99→ JE5021  (31-028435-00)	JN950 (50-028423-00) →07/98 JM5154 (50-029581-00) 08/98→04/99 JM5184 (50-029871-00) Light Blue 04/99→	JJ531 (50-028450-00) →12/98 JH5061 (50-029586-00) 12/98→	HR5033  (24-30715-70/0)	NB958  (x2) 42x53x7mm, FPM (50-319323-00) NB959  35x50x7mm, FPM (50-306644-50) NB847  88x108x11mm, FPM (50-307171-70)			
HBS031  (22-18008B) M10x1.50x102mm (x10)	JD266  (31-028378-00) →07/95 JD5311  (x4) (50-029872-00) 08/95→ JE5021  (31-028435-00)	JN950 (50-028423-00)	JJ531 (50-028450-00)	HR5033  (24-30715-70/0)	NB958  (x2) 42x53x7mm, FPM (50-319323-00) NB959  35x50x7mm, FPM (50-306644-50) NB847  88x108x11mm, FPM (50-307171-70)			



KW/PS



Mondeo 1.8L SCi		06/03 →		130	AC5940 (MLS) (30-029554-00)	DW643 (21-29554-21/0)	
CFBA	1798	4	83.00	Injection, DOHC	96/131		
Mondeo 1.8L TD Diesel		06/93 → 11/00		131	BW010 (Fibre), 1.36mm, 2 Notches (30-027536-00) →0.43 → 0.68mm AB5800 (Fibre), 1.36mm, 2 Teeth [4] (30-027530-00) →0.43 → 0.68mm BW020 (Fibre), 1.42mm, 3 Notches (30-027537-00) →0.681 → 0.74mm AB5810 (Fibre), 1.42mm, 3 Teeth [4] (30-027531-00) →0.681 → 0.74mm BW030 (Fibre), 1.52mm, 4 Notches (30-027538-00) →0.741 → 0.86mm AB5820 (Fibre), 1.52mm, 4 Teeth [4] (30-027532-00) →0.741 → 0.86mm	DT193▲ (21-26448-21/0)	ET192 [6]
RFM/RFN	1753	4	82.50		65/88		
Mondeo 2.0L 16V		11/00 →		132	AD5220 (MLS) (30-029824-00)	CD5220 [16] (21-29824-20/0) CD5221 [17] (21-29824-21/0)	ED5220 (22-29824-00/0)
CJBA/CJBB	1999	4	87.50	Injection, DOHC	107/146		
Mondeo 2.0L 16V DI / TDDi / TDCi Diesel		11/00 →		133	AA5970 (MLS), 1.10mm, 1 Hole (30-029424-00)	CA5970▲ (21-29447-20/0)	EA5970 (22-29508-00/0)
Mondeo 2.0L 16V TDDi / TDCi Diesel		11/00 →					
Mondeo 2.0L TDCi Diesel		10/01 →					
SDBA	1998	4	86.00	TDCi, DOHC	66/89		
D5BA	1998	4	86.00	TDi	66/90		
D6BA/HJBA/HJBB/HJBC	1998	4	86.00	TDi	85/115		
FMBA, N7BA	1998	4	86.00		96/130		
Mondeo 2.0L i		09/96 → 11/00		134	BW650 (Fibre) (30-027479-00) →05/98 BZ490 (MLS) (30-027876-10) 05/98 → 01/99 AE5320 (MLS) (30-029870-00) 01/99 →	DW650 →05/98 DZ491 05/98 → 01/99	EW630 (22-28450-00/0) →12/98 EC5800 (22-29400-00/0) 12/98 →
NGA	1988	4	84.80	DOHC	96/100/ 131/ 136		
NGB/NGC/NGD	1988	4	84.80	DOHC	100/96/ 97/136/ 131/ 132		
Mondeo 2.0L i 16V		01/93 → 08/96		135	BW650 (Fibre) (30-027479-00)	DW650	EW630 (22-28450-00/0)
Mondeo 2.0L i 16V 4x4		04/93 → 08/96					
NGA	1988	4	84.80	DOHC	96/100/ 131/ 136		
NGA	1988	4	84.80		97/132		
Mondeo 2.2L TDCi Diesel		09/04 →		136	AA5970 (MLS), 1.10mm, 1 Hole (30-029424-00) AA5980 (MLS), 1.15mm, 2 Holes (30-029425-00) AA5990 (MLS), 1.20mm, 3 Holes (30-029426-00)		EA5970 (22-29508-00/0)
QJBA/QJBB	2198	4	86.00	TDCi, DOHC	114/155		

								
HBS369  [22-18095B] M10x1.50x145.5mm (x10)	JD5299  (x4) (50-029584-00) JE5037  [18] (31-029578-10)	JM5153 (50-029582-00)		HR5063  (24-31945-10/0)	NA5157  37x50x8mm, PTFE (50-319442-00) LK5005  [3] 88x188x15mm, PTFE (50-319441-00)			 AA5970, AA5980, AA5990  JN816
HBS033  [22-18007B] M12x1.75x136mm (x10)	JD309  (31-026846-00) JD310  (31-026847-00)	JN816 (50-026448-10)	JJ456 [6] (50-026449-00) JJ463 [5] (50-028438-00)	HR801 	NB785 28x38x7mm, FPM (50-305940-50) NB984 66.67x89.3x10mm, FPM (50-306841-50) NA793 79x95.3x11.1mm, MVQ NC086 [3] 79.8x184x18.8mm, PTFE (50-319517-00)		HL5018 [245]  NC044 [15]	 AB5800, AB5810, AB5820  JN950
HBS369  [22-18095B] M10x1.50x145.5mm (x10)	JD5299  (50-029584-00) JE5037  [18] (31-029578-10)	JM5153 [17] (50-029582-00) JM5158 [16] (50-029577-00)		HR5063  (24-31945-10/0)	NA5157  37x50x8mm, PTFE (50-319442-00) LK5005  [3] 88x188x15mm, PTFE (50-319441-00)			 BW650  JJ531
HBS296  [22-18011B] M10x1.50x159mm (x10)	HA5020   (24-29876-00/0) JA5085 →05/02	JM5037 (50-029447-00)	HC5004  (24-29508-00/0)	HR5082  (24-31950-70/0)	NA5028 36x50x7mm, PTFE (50-319486-00) NA5031 50x86.5x13.7mm, PTFE (50-319457-00) NA5030 [3] 106x190x15.2mm, FPM (50-319487-00)			 BZ490  JA5085  JD266
HBS031  [22-18008B] M10x1.50x102mm (x10)	JD5311  (x4) (50-029872-00) →09/99 JD5312  (x4) (50-029873-00) 09/99→ JE5021  (31-028435-00)	JN950 (50-028423-00) →08/98 JM5154 (50-029581-00) 08/98→04/99 JM5184 (50-029871-00) Light Blue 04/99→	JJ531 (50-028450-00) →12/98 JH5061 (50-029586-00) 12/98→	HR5033  (24-30715-70/0)	NB958  (x2) 42x53x7mm, FPM (50-319323-00) NB959 35x50x7mm, FPM (50-306644-50) NB847 88x108x11mm, FPM (50-307171-70)			 JD309  JD310  JD5299  JD5311  JD5312  JE5021  JE5037
HBS031  [22-18008B] M10x1.50x102mm (x10)	JD266  (31-028378-00) →07/95 JD5311  (x4) (50-029872-00) 08/95→ JE5021  (31-028435-00)	JN950 (50-028423-00)	JJ531 (50-028450-00)	HR5033  (24-30715-70/0)	NB958  (x2) 42x53x7mm, FPM (50-319323-00) NB959 35x50x7mm, FPM (50-306644-50) NB847 88x108x11mm, FPM (50-307171-70)			 JE5037  JM5037
HBS296  [22-18011B] M10x1.50x159mm (x10)		JM5037 (50-029447-00)	HC5004  (24-29508-00/0)	HR5082  (24-31950-70/0)	NA5031 50x86.5x13.7mm, PTFE (50-319457-00) NA5030 [3] 106x190x15.2mm, FPM (50-319487-00)			











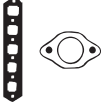

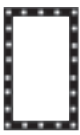

















FORD



KW/PS



Mondeo 2.5L 03/07 → 137					AG8320 (MLS)		
HUBA	2521	5		162/220	(30-029272-00)		
Mondeo 2.5L 24V 06/00 → 11/00 138					AC5880 (MLS)	CC5870	
Mondeo 2.5L ST 200 05/99 → 11/00					(30-029525-00)		
SGA	2495	6	81.60	Injection, DOHC, V6	151/205	AC5870 (MLS)	
SEB/SEC	2495	6	81.60	SPi, DOHC, V6		(30-029524-00)	
Mondeo 2.5L 24V 09/96 → 11/00 139					AC5880 (MLS)	CC5870	
Mondeo 2.5L i 24V 07/94 → 08/96					(30-029525-00)		
SEA	2544	6	81.60	Injection	125/170	AC5870 (MLS)	
						(30-029524-00)	
Mondeo 2.5L V6 24V 11/00 → 140					AC5790 (MLS)		
LCBD	2495	6	81.60	Injection	107/148	(30-029589-00)	
						AC5780 (MLS)	
						(30-029588-00)	
Mondeo 3.0L V6 24V 09/04 → 141					AG7820 (MLS)	CG7810	
Mondeo ST220 04/02 →					AG7810 (MLS)		
REBA	2967	6	89.00	Injection, DOHC, V6	150/204		
MEBA	2967	6	89.00	Injection, DOHC, V6	166/226		
Orion 1.3L 07/90 → 12/93 142					BT140 (Fibre)	DT140	EH752
J4B / BL13/J6A	1297	4	73.96	CFi, HCS	44/60	(30-026496-00)	(21-26496-20/0)
Orion 1.3L 07/83 → 03/86 143					BJ440 (Fibre)	DJ440	EA440
JPA	1296	4	79.96	Carburettor, CVH	51/69	(30-025123-20)	(22-24480-00/0) →12/85
Orion 1.3L 12/85 → 07/90 144					BC240 (Fibre)	DC240	EH752
JBB	1297	4	73.94	Carburettor, HCS	44/60	(30-023756-20)	(21-23756-21/0)
JLA	1297	4	73.94		44/60		
JLA/JLB	1297	4	73.94	Carburettor, OHV	44/60		
Orion 1.4L 12/85 → 12/93 145					BY740 (Fibre)	DY740	EA441
F6F/F6G	1392	4	77.24	Injection, CVH	52/71	(30-025122-20)	(21-24964-20/0)
F6B/F6D/FUA/FUC	1392	4	77.24	Injection, CVH	55/75		(22-25409-00/0)
HL14G	1392	4	77.25		52/72		
Orion 1.4L 07/90 → 12/93 146					BY740 (Fibre)	DY741	EA441
FUH	1392	4	77.24	Injection, PTE	55/75	(30-025122-20)	(22-25409-00/0)
Orion 1.6L 07/83 → 03/86 147					BJ440 (Fibre)	DJ440	EA440
LP1/LPA	1597	4	79.96	Carburettor, CVH	58/79	(30-025123-20)	(22-24480-00/0)
Orion 1.6L i 07/83 → 03/86 148					BJ440 (Fibre)	DJ441	EA440
LR1/LRA	1597	4	79.96	Injection, CVH	66/77/ 90/105	(30-025123-20)	(21-24964-21/0) (22-24480-00/0)

								
						NA5016 35x47x7mm, FPM (50-305690-50) NA5017 98x110x8.5mm, FPM (50-319354-00)		 AC5780  AC5790  AC5870  AC5880  BC240  BJ440  BT140  BY740  HA497  JB799  JB862  JC790  JC829  JD009  JD188  JD498  JD545  JD554  JE719  JN105  JN332  HC440
HBS392 [251] (22-18096B)	JD5747					NA5175 91x108x9.5mm, NBR (50-319459-00)		 HC452  JH5065  JJ348
HBS392 [251] (22-18096B)	JD5747		JH5065 (31-029698-00)			NA5175 91x108x9.5mm, NBR (50-319459-00)		
HBS392 [251] (22-18096B)	JD5747					NA5175 91x108x9.5mm, NBR (50-319459-00)		
HBS392 [251] (22-18096B)		JM5294 JM5293	JH5065 (31-029698-00) →10/03			NA5175 91x108x9.5mm, NBR (50-319459-00)		
HBS050 [22-18001B] M11x1.50x120mm (x10)	JD009 (31-026514-00) JD545 (x4) (31-029228-00) HA497	JN105 (31-027902-00)	HC452 (23-23528-02/0)	HR655 24-30691-15/0		NA576 36.5x52.3x8mm, MVQ (50-306573-00) NB788 79.4x95.3x11.1mm, PTFE (50-306413-50)		
HBS001 [22-18083B] M10x1.50x135mm (x10)	JD498 (31-024472-10) JC829 (31-025656-10) ⊙ JE719	JN332 (31-024964-10)	HC440 (23-24480-00/0)	HR631 (24-30612-25/0) HR661 [1] (50-306802-50)		NA5190 42x56x7mm, FPM (50-307352-70) NB645 35x50x7mm, MVQ NB847 88x108x11mm, FPM (50-307171-70)	NB596 [2] NA585 [2]	
HBS050 [22-18001B] M11x1.50x120mm (x10)	JB862 (31-023758-10) JB799 (x4) (31-023762-20) ⊙ JE719	JN105 (31-027902-00)	HC452 (23-23528-02/0)	HR631 (24-30612-25/0) HR661 [1] (50-306802-50)		NA576 36.5x52.3x8mm, MVQ (50-306573-00) NA793 79x95.3x11.1mm, MVQ NB788 79.4x95.3x11.1mm, PTFE (50-306413-50)	NB596 [2] NB655 [2] NA585 [2]	
HBS001 [22-18083B] M10x1.50x135mm (x10)	JD498 (31-024472-10) JC790 (31-024473-20) ⊙ JE719	JN332 (31-024964-10)	JJ348 (50-025409-10)	HR631 (24-30612-25/0) HR661 [1] (50-306802-50)		NA5190 42x56x7mm, FPM (50-307352-70) NB645 35x50x7mm, MVQ NB847 88x108x11mm, FPM (50-307171-70)	NB596 [2] NB655 [2] NA579 [2] NA585 [2]	
HBS001 [22-18083B] M10x1.50x135mm (x10)	JD188 (31-027056-00) JD554 (31-029517-00) JC829 (31-025656-10)	JN332 (31-024964-10)	JJ348 (50-025409-10)	HR631 (24-30612-25/0) HR661 [1] (50-306802-50)		NA5190 42x56x7mm, FPM (50-307352-70) NB645 35x50x7mm, MVQ NB847 88x108x11mm, FPM (50-307171-70)		
HBS001 [22-18083B] M10x1.50x135mm (x10)	JD498 (31-024472-10) JD5746 (31-025159-10) JC829 (31-025656-10) ⊙ JE719	JN332 (31-024964-10)	HC440 (23-24480-00/0)	HR631 (24-30612-25/0) HR661 [1] (50-306802-50)		NA5190 42x56x7mm, FPM (50-307352-70) NB645 35x50x7mm, MVQ NB847 88x108x11mm, FPM (50-307171-70)	NB596 [2] NB655 [2] NA585 [2]	
HBS001 [22-18083B] M10x1.50x135mm (x10)	JD498 (31-024472-10) JD5746 (31-025159-10) JC829 (31-025656-10) ⊙ JE719	JN332 (31-024964-10)	HC440 (23-24480-00/0)	HR631 (24-30612-25/0) HR661 [1] (50-306802-50)		NA5190 42x56x7mm, FPM (50-307352-70) NB645 35x50x7mm, MVQ NB847 88x108x11mm, FPM (50-307171-70)	NB596 [2] NB655 [2] NA585 [2]	











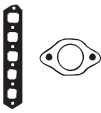

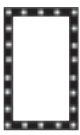

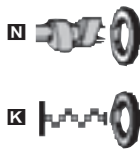

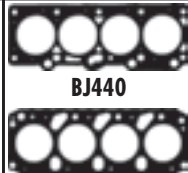

















































































FORD



KW/PS



Model				Year Range	Power (KW/PS)	Configuration	Part Number	Accessories
Orion 1.6L				12/85 → 07/90	149			
LUC	1597	4	79.96	Carburettor, CVH	66/90	BJ440 (Fibre) (30-025123-20)	DJ442	EA441 (22-25409-00/0)
Orion 1.6L i				03/86 → 07/90	150			
LRB	1597	4	79.96	Injection, CVH	66/77/ 90/105	BJ440 (Fibre) (30-025123-20)	DJ441 (21-24964-21/0)	EA441 (22-25409-00/0)
Orion 1.6L i				03/86 → 07/90	151			
L4B	1598	4	79.96	Injection, CVH	66/77/ 90/105	BJ440 (Fibre) (30-025123-20)	DJ441 (21-24964-21/0)	EA441 (22-25409-00/0)
Orion 1.6L i				08/89 → 07/90	152			
LJB	1597	4	79.96	Injection, CVH	66/77/ 90/105	BJ440 (Fibre) (30-025123-20)	DJ441 (21-24964-21/0)	EA441 (22-25409-00/0)
Orion 1.6L				07/90 → 12/92	153			
LUJ/LUK	1597	4	79.96	Carburettor, CVH	65/66/ 71/88/ 90/96	BJ440 (Fibre) (30-025123-20)	DJ442	EA441 (22-25409-00/0)
Orion 1.6L i				07/90 → 09/92	154			
LJF	1597	4	79.96	Efi, CVH	75-81/ 102- 110	BJ440 (Fibre) (30-025123-20)	DJ444 (21-24964-22/0)	EA441 (22-25409-00/0)
Orion 1.6L i 16V				07/92 → 12/93	155			
LIE	1597	4	76.00	DOHC	66/90	BW630 (Fibre) (30-028039-00)	DW630 (21-28423-20/0)	EW630 (22-28450-00/0)
LTK	1597	4	76.00	Injection, DOHC	66/90			
Orion 1.6L D Diesel				02/84 → 01/89	156			
LTA/LTC	1608	4	80.00	SOHC	40/54	BM950 (Fibre), 1.36mm, 2 Holes (30-024950-10) BM960 (Fibre), 1.42mm, 3 Holes (30-024951-10) BM980 (Fibre), 1.52mm, 4 Holes (30-026287-10)	DM940▲ (21-24949-21/0)	
Orion 1.8L i 16V				01/92 → 12/93	157			
RDA	1796	4	80.60	DOHC	77/105	BW640 (Fibre) (30-028040-00)	DW640	EW630 (22-28450-00/0)
RQB	1796	4	80.60	DOHC	96/131			

								 BJ440	 JJ531
HBS001  (22-18083B) M10x1.50x135mm (x10)	JD498  (31-024472-10) JD5746  (31-025159-10) JC790  (31-024473-20)  JE719	JN332 (31-024964-10)	JJ348 (50-025409-10)	HR631  (24-30612-25/0) HR661  [1] (50-306802-50)	NA5190  42x56x7mm, FPM (50-307352-70) NB645  35x50x7mm, MVQ NB847  88x108x11mm, FPM (50-307171-70)	NB596 [2]  NB655 [2]  NA585 [2] 	BM950, BM960, BM980 BW630, BW640 JC565 JC724 JC790 JC829 JD188 JD264 JD265 JD498 JE5021 JE5022 JE719 HL474 JN332 JN950 JJ334 JJ348		
HBS001  (22-18083B) M10x1.50x135mm (x10)	JD498  (31-024472-10) JC829  (31-025656-10)  JE719	JN332 (31-024964-10)	JJ348 (50-025409-10)	HR631  (24-30612-25/0) HR661  [1] (50-306802-50)	NA5190  42x56x7mm, FPM (50-307352-70) NB645  35x50x7mm, MVQ NB847  88x108x11mm, FPM (50-307171-70)	NB596 [2]  NB655 [2]  NA585 [2] 			
HBS001  (22-18083B) M10x1.50x135mm (x10)	JD498  (31-024472-10) JD5746  (31-025159-10) JC829  (31-025656-10)  JE719	JN332 (31-024964-10)	JJ348 (50-025409-10)	HR631  (24-30612-25/0) HR661  [1] (50-306802-50)	NA5190  42x56x7mm, FPM (50-307352-70) NB645  35x50x7mm, MVQ NB847  88x108x11mm, FPM (50-307171-70)				
HBS001  (22-18083B) M10x1.50x135mm (x10)	JD498  (31-024472-10) JC829  (31-025656-10)	JN332 (31-024964-10)	JJ348 (50-025409-10)	HR631  (24-30612-25/0) HR661  [1] (50-306802-50)	NA5190  42x56x7mm, FPM (50-307352-70) NB645  35x50x7mm, MVQ NB847  88x108x11mm, FPM (50-307171-70)				
HBS001  (22-18083B) M10x1.50x135mm (x10)	JD498  (31-024472-10) JD5746  (31-025159-10) JC790  (31-024473-20)  JE719	JN332 (31-024964-10)	JJ348 (50-025409-10)	HR631  (24-30612-25/0) HR661  [1] (50-306802-50)	NA5190  42x56x7mm, FPM (50-307352-70) NB645  35x50x7mm, MVQ NB847  88x108x11mm, FPM (50-307171-70)	NB596 [2]  NB655 [2]  NA579 [2] 			
HBS001  (22-18083B) M10x1.50x135mm (x10)	JD188  (31-027056-00) JC724  (31-027055-00) JC829  (31-025656-10)	JN332 (31-024964-10)	JJ348 (50-025409-10)	HR661  [1] (50-306802-50)	NA5190  42x56x7mm, FPM (50-307352-70) NB645  35x50x7mm, MVQ NB847  88x108x11mm, FPM (50-307171-70)				
HBS031  (22-18008B) M10x1.50x102mm (x10)	JD265  (31-028392-00) JD264  (31-028430-00) JE5021  (31-028435-00)	JN950 (50-028423-00)	JJ531 (50-028450-00)	HR5033  (24-30715-70/0)	NB958  (x2) 42x53x7mm, FPM (50-319323-00) NB959  35x50x7mm, FPM (50-306644-50) NB847  88x108x11mm, FPM (50-307171-70)				
HBS007  (22-18085B)	JC565  (31-025104-10) JE5022  (31-025105-10)	HL474  (24-24961-00/0)	JJ334 (50-024962-00)	HR659  (24-30591-25/0)	NB785  28x38x7mm, FPM (50-305940-50) NB786  42x58x11mm, FPM (50-305941-50) NB788  79.4x95.3x11.1mm, PTFE (50-306413-50)	NB596 [2]  NB655 [2]  NA585 [2] 			
HBS031  (22-18008B) M10x1.50x102mm (x10)	JD265  (31-028392-00) JD264  (31-028430-00) JE5021  (31-028435-00)	JN950 (50-028423-00)	JJ531 (50-028450-00)	HR5033  (24-30715-70/0)	NB958  (x2) 42x53x7mm, FPM (50-319323-00) NB959  35x50x7mm, FPM (50-306644-50) NB847  88x108x11mm, FPM (50-307171-70)				











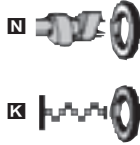

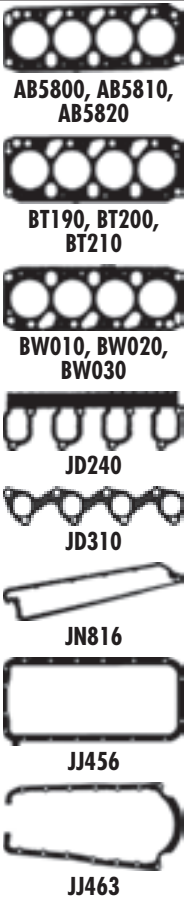















FORD



KW/PS



Orion 1.8L D Diesel					01/89 → 07/90	158			
RTA/RTB	1753	4	82.50	Indirect Injection	44/60	BT190 (Fibre), 1.36mm, 2 Teeth [4] (30-026353-10) → 0.43 → 0.68mm BT200 (Fibre), 1.42mm, 3 Teeth [4] (30-026354-10) → 0.681 → 0.74mm BT210 (Fibre), 1.52mm, 4 Teeth [4] (30-026355-10) → 0.741 → 0.86mm	DT193▲ (21-26448-21/0)	ET190 [27] (22-26449-00/0) ET191 [6] (22-28438-00/0)	
Orion 1.8L D Diesel					11/90 → 12/93	159			
RTE/RTF/RTH	1753	4	82.50	Indirect Injection	44/60	BT190 (Fibre), 1.36mm, 2 Teeth [4] (30-026353-10) → 09/92 → 0.43 → 0.68mm BT200 (Fibre), 1.42mm, 3 Teeth [4] (30-026354-10) → 08/92 → 0.681 → 0.74mm BT210 (Fibre), 1.52mm, 4 Teeth [4] (30-026355-10) → 08/92 → 0.741 → 0.86mm BW010 (Fibre), 1.36mm, 2 Notches (30-027536-00) 09/92 → → 0.43 → 0.68mm AB5800 (Fibre), 1.36mm, 2 Teeth [4] (30-027530-00) 09/92 → → 0.43 → 0.68mm BW020 (Fibre), 1.42mm, 3 Notches (30-027537-00) 09/92 → → 0.681 → 0.74mm AB5810 (Fibre), 1.42mm, 3 Teeth [4] (30-027531-00) 09/92 → → 0.681 → 0.74mm BW030 (Fibre), 1.52mm, 4 Notches (30-027538-00) 09/92 → → 0.741 → 0.86mm AB5820 (Fibre), 1.52mm, 4 Teeth [4] (30-027532-00) 09/92 → → 0.741 → 0.86mm	DT193▲ (21-26448-21/0)	ET190 [27] (22-26449-00/0) → 11/93 ET191 [6] (22-28438-00/0) → 11/93 ET192	







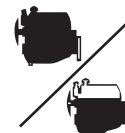



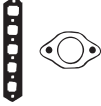

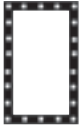

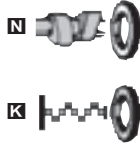













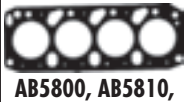













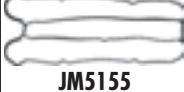

















































							
HBS007  (22-18085B) →07/92 HBS033  (22-18007B) M12x1.75x136mm (x10) 07/92→	JD240  (31-026450-00) JD310  (31-026847-00)	JN816 (50-026448-10)	JJ456 [6] (50-026449-00) JJ463 [5] (50-028438-00)	HR659  (24-30591-25/0)	NB785  28x38x7mm, FPM (50-305940-50) NB984  66.67x89.3x10mm, FPM (50-306841-50) NA793  79x95.3x11.1mm, MVQ	HL5018 [245]  NB596 [2]  NA585 [2]  NJ004 [2]  NC044 [15]	
HBS007  (22-18085B) →08/92 HBS033  (22-18007B) M12x1.75x136mm (x10) 09/92→	JD240  (31-026450-00) JD310  (31-026847-00)	JN816 (50-026448-10)	JJ456 [6] (50-026449-00) JJ463 [5] (50-028438-00)	HR659  (24-30591-25/0) →08/92 HR801  09/92→	NB785  28x38x7mm, FPM (50-305940-50) NB984  66.67x89.3x10mm, FPM (50-306841-50) NA793  79x95.3x11.1mm, MVQ NC086  [3] 79.8x184x18.8mm, PTFE (50-319517-00)	HL5018 [245]  NB596 [2]  NA585 [2]  NJ004 [2]  NC044 [15]	



KW/PS



Orion 1.8L TD Diesel				03/92 → 12/93		160	BW010 (Fibre), 1.36mm, 2 Notches (30-027536-00) → 0.43 → 0.68mm AB5800 (Fibre), 1.36mm, 2 Teeth [4] (30-027530-00) → 0.43 → 0.68mm BW020 (Fibre), 1.42mm, 3 Notches (30-027537-00) → 0.681 → 0.74mm AB5810 (Fibre), 1.42mm, 3 Teeth [4] (30-027531-00) → 0.681 → 0.74mm BW030 (Fibre), 1.52mm, 4 Notches (30-027538-00) → 0.741 → 0.86mm AB5820 (Fibre), 1.52mm, 4 Teeth [4] (30-027532-00) → 0.741 → 0.86mm	DT193▲ (21-26448-21/0)	ET190 [5] (22-26449-00/0) → 11/93 ET191 [6] (22-28438-00/0) → 11/93 ET192 11/93 →
RFD/RFK	1753	4	82.50	Indirect Injection	66/89				
P 100 1.8L TD Diesel				10/87 → 12/92		161	BT190 (Fibre), 1.36mm, 2 Teeth [4] (30-026353-10) → 0.43 → 0.68mm BT200 (Fibre), 1.42mm, 3 Teeth [4] (30-026354-10) → 0.681 → 0.74mm BT210 (Fibre), 1.52mm, 4 Teeth [4] (30-026355-10) → 0.741 → 0.86mm	DT193▲ (21-26448-21/0)	ET190 [5] (22-26449-00/0) ET191 [6] (22-28438-00/0)
RFA	1753	4	82.50	Indirect Injection	54/75				
P 100 2.0L				10/87 →		162	AH860 (Fibre) (30-025148-10)	CH864 (21-25148-40/0)	EH850 (22-22677-00/0)
NAE	1993	4	90.80	Carburettor, SOHC	57/77				
Puma Coupe 1.4L 16V				11/97 → 10/00		163	BY660 (MLS) (30-028820-00) → 05/98 AB5130 (MLS) (30-029249-00) 06/98 →	DY660 (21-28820-20/0) → 05/98 CB5130 [17] (21-28820-30/0) 06/98 →	EY650 (22-28750-00/0)
FHD/FHF	1388	4	76.00	Injection, DOHC	55/90				
Puma Coupe 1.6L 16V				08/00 →		164	AC5860 (MLS), 1.25mm (30-029526-00)		
L1W	1596	4	79.00	Injection, DOHC	76/103				
Puma Coupe 1.7L 16V				03/97 →		165	AC5290 (MLS) (30-029406-00)	CC5290	
MHB	1679	4	80.00	DOHC	65/88				
MHA	1679	4	80.00	DOHC	92/125				
Ranger 2.5L D Diesel				10/99 → 04/02		166	AA5130 (MLS) (30-029438-00)	CA5130 (21-29438-20/0)	
Ranger 2.5L D 4x4 Diesel				10/99 → 04/02					
Ranger 2.5L TD Diesel				04/02 →					
Ranger 2.5L TD 4x4 Diesel				10/99 →					
WL	2500	4	93.00	Indirect Injection	57/77				
WL-T	2500	4	93.00	Indirect Injection	80/109				











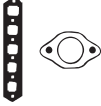

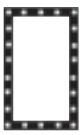

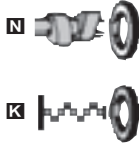

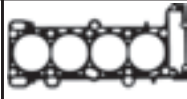









































































								
HBS033  [22-18007B] M12x1.75x136mm (x10)	JD309  (31-026846-00) JD310  (31-026847-00)	JN816 (50-026448-10)	JJ456 [6] (50-026449-00) JJ463 [5] (50-028438-00)	HR801 	 NB785 28x38x7mm, FPM (50-305940-50)  NB984  66.67x89.3x10mm, FPM (50-306841-50)  NA793  79x95.3x11.1mm, MVQ  NC086  [3] 79.8x184x18.8mm, PTFE (50-319517-00)	HL5018 [245]  NC044 [15]	 AB5130  AB5800, AB5810, AB5820  AC5290  AC5860  AH860  BT190, BT200, BT210  BW010, BW020, BW030  BY660  JA768  JA769  JA770  JD240  JD309  JD310  JD5164  JD5230  JD5290  JM5155	 JN620  JN816  HC285  JE5025  JJ456  JJ463
HBS007  [22-18085B]	JD240  (31-026450-00) JD310  (31-026847-00)	JN816 (50-026448-10)	JJ456 [6] (50-026449-00) JJ463 [5] (50-028438-00)	HR659  (24-30591-25/0)	 NB785 28x38x7mm, FPM (50-305940-50)  NB984  66.67x89.3x10mm, FPM (50-306841-50)  NA793  79x95.3x11.1mm, MVQ	HL5018 [245]  NB596 [2]  NA585 [2]  NJ004 [2]  NC044 [15]	 W010, W020, W030  BY660  JA768  JA769  JA770	
HBS056  [22-18002B] M12x1.75x92.5mm (x10)	JA769  (31-022642-10) JA768  (31-022672-10) JA770  (x3) (31-022671-10)	JN620 (31-024963-40)	HC285  (23-22677-00/0)	HR631  (24-30612-25/0) HR661  [1] (50-306802-50)	 NA5190  (x2) 42x56x7mm, FPM (50-307352-70)  NA5190  42x56x7mm, FPM (50-307352-70)  NA793  79x95.3x11.1mm, MVQ		 JA768  JA769  JA770	
HBS078  [22-18086B] M10x1.50x143mm (x10)	JD5230  (x2) (50-028751-00) →05/98 JD5290  (x2) (50-029699-00) 06/98 → JD5164  (31-029032-00)	JM5155 [17] (50-029587-00)	JE5025 (31-028750-00)	HR809  (50-319363-00) HR808  (50-319362-00)	 NC048 (x2) 37.2x52.35x6mm, FPM (50-319368-00)  NA5137  32.9x47.4x5mm, FPM (50-319367-00)  LK5004  [3] 80x182x19.4mm, PTFE (50-307318-70)		 JD240  JD309  JD310  JD5164	
HBS078  [22-18086B] M10x1.50x143mm (x10)								
HBS415 [22-18097B]								
HBS288  [22-75006B] M12x1.50x113mm (x10) M10x1.25x100mm (x8)					 NA5196  53x69.85x11mm, MVQ			



KW/PS



Scorpio 1.8L				04/85 → 02/92		167	BN150 (Fibre) (30-027359-00)		DN150 (21-24963-20/0)	EH850 (22-22677-00/0)
REC	1796	4	86.20	SOHC		66/89				
Scorpio 2.0L				11/88 → 10/92		168	BX550 (MLS) (30-028387-10)		DX550 (21-26709-40/0)	
N8A	1998	4	86.00	Carburettor, DOHC		80/109				
Scorpio 2.0L				04/85 → 08/89		169	AH860 (Fibre) (30-025148-10)		CH864 (21-25148-40/0)	EH850 (22-22677-00/0)
N8D/NEL	1993	4	90.80	Injection, DOHC		77/105				
Scorpio 2.0L i				05/89 → 09/94		170	BT480 (Fibre) (30-025729-00)		DT482[20] (21-25729-40/0)	EX550 (22-26643-00/0)
N9F	1998	4	86.00	EFI, DOHC		85/116				
N9D	1998	4	86.00	DOHC		88/120	BX550 (MLS) (30-028387-10)	DX550[21] (21-26709-40/0)		
N9B	1998	4	86.00			92/125	AC5910 (MLS), 1.60mm (30-029401-00)			
Scorpio 2.0L i				10/94 → 08/98		171	AC5910 (MLS), 1.60mm (30-029401-00)			
NSD	1998	4	86.00	EFI, DOHC		85/116				
Scorpio 2.0L i				04/85 → 09/94		172	AH860 (Fibre) (30-025148-10)		CH865 (21-25148-26/0)	EH850 (22-22677-00/0)
NRA/NRI	1993	4	90.80	EFI, SOHC		85/115				
NRC	1995	4	90.83	EFI, SOHC		74/100				
Scorpio 2.0L i 16V				10/94 → 08/98		173	BY640 (MLS) (30-028389-10)		DY641	
N3A	1998	4	86.00	Injection, DOHC		100/136				
Scorpio 2.0L Mk I				06/89 → 03/93		174				
N8B	1984	4	86.00	DOHC		80-92/ 109- 125				
Scorpio 2.3L i 16V				06/96 → 08/98		175	AC5680 (MLS) (30-029402-00)		CC5680	
Y5A	2295	4	89.60	SPi, DOHC		108/147				
Scorpio 2.4L i				09/86 → 10/94		176			DT500▲■ (21-26027-20/0)	
ARD	2394	6	84.00	EFI, V6		92/125				
ARC	2394	6	84.00	EFI, V6		96/131				
Scorpio 2.5L D Diesel				12/89 → 12/94		177	BP890 (Fibre), 1.53mm, 2 Notches (30-026144-10)		DH890▲■	GH890▲○ (20-24586-05/0)
STR (XD3/XD3P)	2498	4	94.00			51/69	BP900 (Fibre), 1.63mm, 3 Notches (30-026145-10)			
							BP910 (Fibre), 1.73mm, 4 Notches (30-026146-10)			

									
HBS056  (22-18002B) M12x1.75x92.5mm (x10)	JA769  (31-022642-10) JA768  (31-022672-10) JA770  (x3) (31-022671-10) 	JN620 (31-024963-40)	HC285  (23-22677-00/0)	HR631  (24-30612-25/0)	NA5190 42x56x7mm, FPM (50-307352-70) NA5190  42x56x7mm, FPM (50-307352-70) NA793  79x95.3x11.1mm, MVQ	NB655 [2]  KA289 [13] KT738 [14]		AC5680 AC5910 AH860 BN150 BP890, BP900, BP910 BT480 BX550 BY640 JA768 JA769 JA770 JC566 JD5268 JD542 JD543 JE5020 JE719 JN245 JN620 JN662	JN817 HC285 HC346 JJ457
HBS032  (22-18003B) M11x1.50x178mm (x10)	JD542  (31-026711-00) JD543  (x2) (31-026640-00)	JN817 (50-026709-00)	JJ457 (50-026643-00)	HR655  24-30691-15/0	NB645 35x50x7mm, MVQ NA5190  42x56x7mm, FPM (50-307352-70) NB847  88x108x11mm, FPM (50-307171-70)	NB596 [2]  NB655 [2] 			
HBS056  (22-18002B) M12x1.75x92.5mm (x10)	JA769  (31-022642-10) JA768  (31-022672-10) JA770  (x3) (31-022671-10) 	JN620 (31-024963-40)	HC285  (23-22677-00/0)	HR631  (24-30612-25/0) HR661  [1] (50-306802-50)	NA5190  (x2) 42x56x7mm, FPM (50-307352-70) NA5190  42x56x7mm, FPM (50-307352-70) NA793  79x95.3x11.1mm, MVQ	NA580 [2]  NB655 [2]  NA585 [2]  KA289 [13] KT738 [14]			
HBS032  (22-18003B) M11x1.50x178mm (x10)	JD542  (x2) (31-026711-00) JD543  (x2) (31-026640-00)	JN817 (50-026709-00)	JJ457 (50-026643-00)	HR655  24-30691-15/0	NB645 35x50x7mm, MVQ NA5190  42x56x7mm, FPM (50-307352-70) NB847  88x108x11mm, FPM (50-307171-70)	NB596 [2]  NB655 [2] 			
HBS032  (22-18003B) M11x1.50x178mm (x10)	JD542  (x2) (31-026711-00) JD543  (x2) (31-026640-00)	JN817 (50-026709-00)	JJ457 (50-026643-00)	HR655  24-30691-15/0	NB645 35x50x7mm, MVQ NA5190  42x56x7mm, FPM (50-307352-70) NB847  88x108x11mm, FPM (50-307171-70)				
HBS056  (22-18002B) M12x1.75x92.5mm (x10)	JA769  (31-022642-10) JA768  (31-022672-10) JA770  (x3) (31-022671-10) 	JN620 (31-024963-40)	HC285  (23-22677-00/0)	HR631  (24-30612-25/0) HR661  [1] (50-306802-50)	NA5190  (x2) 42x56x7mm, FPM (50-307352-70) NA5190  42x56x7mm, FPM (50-307352-70) NA793  79x95.3x11.1mm, MVQ	NA580 [2]  NB655 [2]  NA585 [2]  KA289 [13] KT738 [14]			
HBS032  (22-18003B) M11x1.50x178mm (x10)				HR655  (x2) 24-30691-15/0	NA5190  42x56x7mm, FPM (50-307352-70) NA5190  42x56x7mm, FPM (50-307352-70) NB847  88x108x11mm, FPM (50-307171-70)				
				HR655  24-30691-15/0	NB645 35x50x7mm, MVQ NA5190  42x56x7mm, FPM (50-307352-70) NB847  88x108x11mm, FPM (50-307171-70)				
HBS032  (22-18003B) M11x1.50x178mm (x10)		HM5238 		HR655  (x2) 24-30691-15/0	NA5177  42x56x7mm, FPM (50-319189-00)				
HBS057  (22-18004B) M12x1.75x87mm (x16)	JD5268  (31-026083-00) JE5020  (x6) (31-026084-00)	JN662 (x2) (31-026027-00)		HR660 	NA5190  42x56x7mm, FPM (50-307352-70) NB564  60.5x76.2x10mm, FPM (50-307219-70)				
HBS016  (22-53005B) M11x1.50x120mm (x7) M11x1.50x107.5mm (x15)	JC566  (x2)	JN245 (50-024586-00)	HC346  PA349 (33-102290-10) 22x16x2mm	PA229 (x8) (50-324505-00)	NF780  45x60x7mm, ACM KS696  (31-025367-10)				











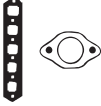

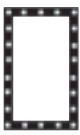

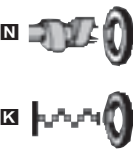

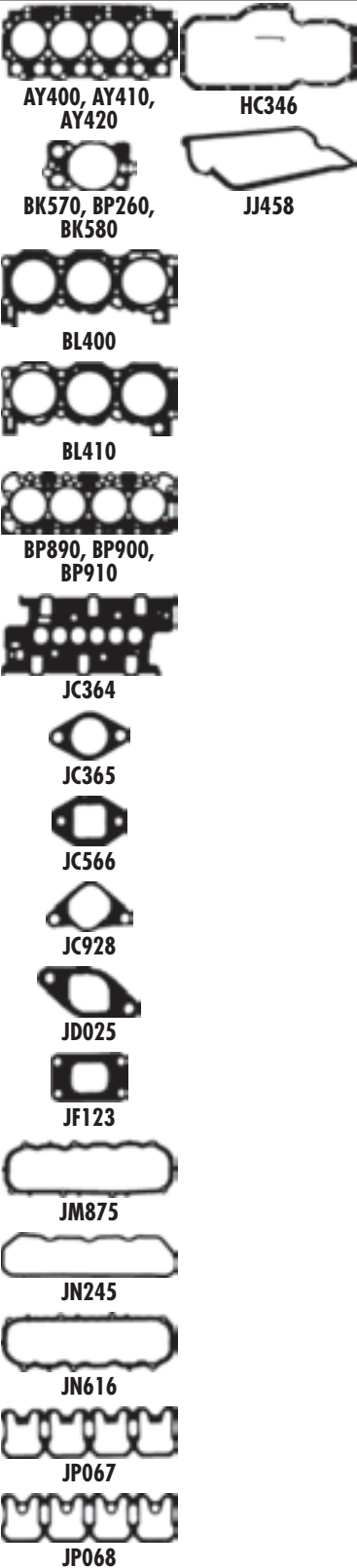















FORD



KW/PS



Scorpio 2.5L D Diesel				12/85 → 02/92	178			
STR (XD3/XD3P)	2498	4	94.00		51/69	BP890 (Fibre), 1.53mm, 2 Notches (30-026144-10) BP900 (Fibre), 1.63mm, 3 Notches (30-026145-10) BP910 (Fibre), 1.73mm, 4 Notches (30-026146-10)	DH890 ▲■	GH890 ▲○ (20-24586-05/0)
Scorpio 2.5L TD Diesel				06/88 → 07/93	179			
SFA (XD3T)/SFB (XD3T)	2498	4	94.00		68/92	BP890 (Fibre), 1.53mm, 2 Notches (30-026144-10) BP900 (Fibre), 1.63mm, 3 Notches (30-026145-10) BP910 (Fibre), 1.73mm, 4 Notches (30-026146-10)	DG052 ▲ (21-24586-25/0)	GM310 ▲
Scorpio 2.5L TD Diesel				08/93 → 08/98	180			
SCB/SCC VM	2500 2500	4 4	92.00 92.00		85/115 92/125	AY400 (MLS), 1.42mm, 0 Notches (30-028472-00) BK570 (Fibre), 1.42mm, 0 Notches (x4) (30-025008-20) AY410 (MLS), 1.52mm, 2 Notches (30-028473-00) BP260 (Fibre), 1.52mm, 2 Notches (x4) (30-025013-20) AY420 (MLS), 1.62mm, 1 Notch (30-028474-00) BK580 (Fibre), 1.62mm, 1 Notch (x4) (30-025007-20)	DK570 ▲ [7] (21-25850-21/0)	GK572 ▲ [8] (20-25850-01/0)
Scorpio 2.8L i				04/85 → 11/86	181			
Scorpio 2.8L i 4x4				10/85 → 11/86				
PRE	2792	6	93.00	EFI, V6	110/150	BL400 (Fibre) ◀ (30-025150-10) BL410 (Fibre) ▶	DL401 [31] DL402 [32]	

								
HBS015  (22-53004B) M11x1.50x97.5mm (x8) M11x1.50x120mm (x7) M11x1.50x107.5mm (x7) →09/87 HBS016  (22-53005B) M11x1.50x120mm (x7) M11x1.50x107.5mm (x15) HBS229  (22-53001B) M11x1.50x97.5mm (x7) M11x1.50x97mm (x1) M11x1.50x120mm (x7) M11x1.50x107.5mm (x7) →09/87	JC566  (x2)	JN245 (50-024586-00)	HC346  PA349 (33-102290-10) 22x16x2mm	PA229 (x8) (50-324505-00)	NF780  45x60x7mm, ACM KS696  (31-025367-10)			AY400, AY410, AY420 HC346 BK570, BP260, BK580 JJ458 BL400 BL410 BP890, BP900, BP910
HBS015  (22-53004B) M11x1.50x97.5mm (x8) M11x1.50x120mm (x7) M11x1.50x107.5mm (x7) →09/87 HBS229  (22-53001B) M11x1.50x97.5mm (x7) M11x1.50x97mm (x1) M11x1.50x120mm (x7) M11x1.50x107.5mm (x7) 09/87→		JN245 (50-024586-00)	HC346  PA349 (33-102290-10) 22x16x2mm	PA229 (x8) (50-324505-00)	NF097 (x2) 45x62x10mm, NBR NF780  45x60x7mm, ACM KS696  (31-025367-10)			JC364 JC365 JC566 JC928 JD025 JF123
HBS108  (22-56003B) M14x2.0x137mm (x10) M12x1.75x115mm (x4) M12x1.75x79.5mm (x4)	JC928  (31-025852-10) JD025  (31-025849-10) JF123  (31-027523-00)	JP067 (31-025850-10) JP068 [9] (31-029626-00)						JM875 JN245 JN616
	JC364  (31-024452-10) JC365  (x6) (32-206600-10)	JM875 (x2) [31] (31-021055-10) JN616 (x2) [32] (31-021055-30)	JJ458 (50-025667-00)	HR633  (50-022425-10) HR630 	NA5190  42x56x7mm, FPM (50-307352-70) NA5190  42x56x7mm, FPM (50-307352-70) NB564  60.5x76.2x10mm, FPM (50-307219-70)	NA580 [2]  NA585 [2] 		JP067 JP068











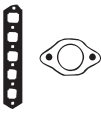

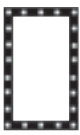

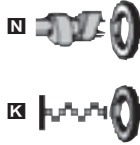

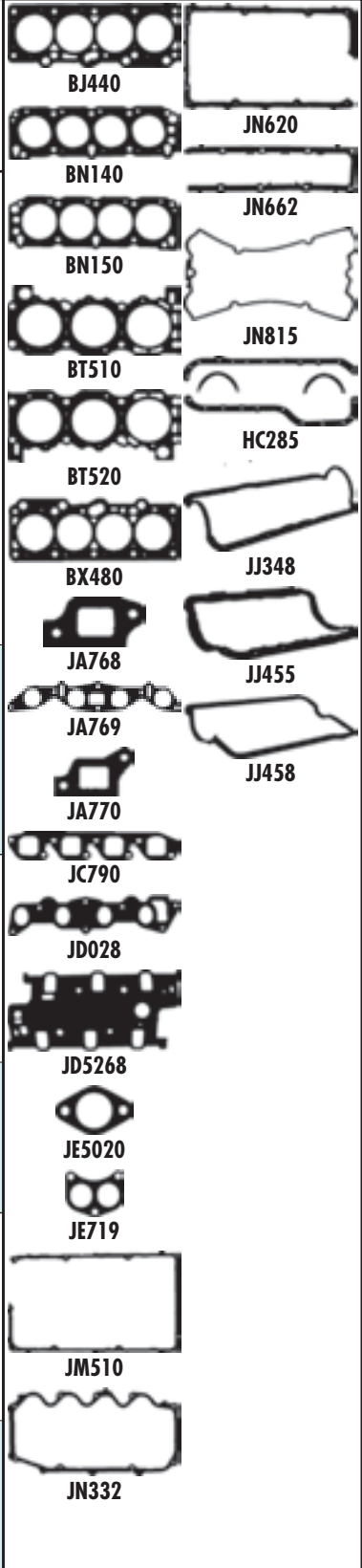















































FORD



KW/PS



Scorpio 2.9L 24V						08/93 → 09/94	182	BT510 (Fibre) (30-026081-00)	DT510 (21-26027-21/0)	ET490 (22-25667-02/0)	GT510		
Scorpio 2.9L i						09/86 → 08/98							
Scorpio 2.9L i 24V						04/91 → 08/98							
Scorpio 2.9L i 4x4						09/86 → 10/94							
BOA/BOB	2935	6	93.00	EFI, V6	143/ 152/ 195/ 207								
BRC	2935	6	93.00	Injection, V6	143/ 152/ 195/ 207								
BRD/BRE/BRF/BRG	2935	6	93.00	EFI, V6	143/ 152/ 195/ 207								
Sierra 1.3L						08/82 → 12/86	183			EH850 (22-22677-00/0)			
JCT	1294	4	79.00	SOHC	44/60								
Sierra 1.6L						08/82 → 02/93	184	BN140 (Fibre) (30-025540-10)	DN140	EH850 (22-22677-00/0)			
LSD/LSE/LCS/LCT	1593	4	81.30	SOHC	55/75								
LSF	1597	4	81.30	SOHC	58/79 53/72								
Sierra 1.6L i						10/89 → 02/93	185	BJ440 (Fibre) (30-025123-20)	DJ445	EA441 (22-25409-00/0)			
L6B	1597	4	79.96	CFI, CVH	59/80								
Sierra 1.8L						10/84 → 09/89	186	BN150 (Fibre) (30-027359-00)	DN150 (21-24963-20/0)	EH850 (22-22677-00/0)			
R2A/REB/RED/REF	1796	4	86.20	SOHC	66/89								
Sierra 1.8L						05/88 → 02/93	187	BX480 (Fibre) (30-026512-00)	DX480 (21-26512-22/0)	EX480			
R2C	1769	4	79.94	Carburettor, SOHC	64/87								
R6A	1769	4	79.94	Carburettor, SOHC	64-66/ 87-90								







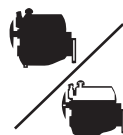



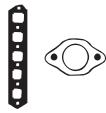

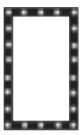

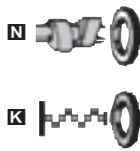















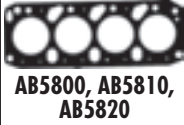









































								
HBS057  [22-18004B] M12x1.75x87mm (x16) HBS140  [22-18088B] M12x1.75x115mm (x16)	JD5268  (31-026083-00) JE5020  (x6) (31-026084-00)	JN662 (x2) (31-026027-00) HM5236 	JJ458 (50-025667-00)	HR660 	NA5190  42x56x7mm, FPM (50-307352-70) NB564  60.5x76.2x10mm, FPM (50-307219-70)	NB596 [2] 	BJ440 JN620 BN140 JN662 BN150 JN815 BT510 HC285 BT520 JJ348 BX480 JJ455 JA768 JA769 JA770 JJ458 JC790 JD028 JD5268 JE5020 JE719 JM510 JN332	
HBS056  [22-18002B] M12x1.75x92.5mm (x10)	JA769  (31-022642-10) JA768  (31-022672-10) JA770  (x3) (31-022671-10) 	JM510 (31-022641-20)	HC285  (23-22677-00/0)	HR631  (24-30612-25/0) HR661  [1] (50-306802-50)	NA5190  42x56x7mm, FPM (50-307352-70) NA793  79x95.3x11.1mm, MVQ (50-306802-50)	NB655 [2]  KA289 [13] KT738 [14]		
HBS056  [22-18002B] M12x1.75x92.5mm (x10)	JA769  (31-022642-10) JA768  (31-022672-10) JA770  (x3) (31-022671-10) 	JN620 (31-024963-40)	HC285  (23-22677-00/0)	HR631  (24-30612-25/0) HR661  [1] (50-306802-50)	NA5190  42x56x7mm, FPM (50-307352-70) NA5190  42x56x7mm, FPM (50-307352-70) NA793  79x95.3x11.1mm, MVQ	NB655 [2]  KA289 [13] KT738 [14]		
HBS001  [22-18083B] M10x1.50x135mm (x10)		JN332 (31-024964-10)	JJ348 (50-025409-10)	HR631  (24-30612-25/0) HR661  [1] (50-306802-50)	NA5190  42x56x7mm, FPM (50-307352-70) NB645  35x50x7mm, MVQ NB847  88x108x11mm, FPM (50-307171-70)	NB655 [2]  KT738 [14]		
HBS056  [22-18002B] M12x1.75x92.5mm (x10)	JA769  (31-022642-10) JA768  (31-022672-10) JA770  (x3) (31-022671-10) 	JN620 (31-024963-40)	HC285  (23-22677-00/0)	HR631  (24-30612-25/0)	NA5190  42x56x7mm, FPM (50-307352-70) NA5190  42x56x7mm, FPM (50-307352-70) NA793  79x95.3x11.1mm, MVQ	NB655 [2]  KA289 [13] KT738 [14]		
HBS006  [22-18084B] M10x1.50x133mm (x10)	JD028  (31-026604-00) JC790 (31-024473-20)	JN815 (50-026603-00)	JJ455 (50-026610-00)	HR661  [1] (50-306802-50)	NA5190  42x56x7mm, FPM (50-307352-70) NB645  35x50x7mm, MVQ NB847  88x108x11mm, FPM (50-307171-70)	NB655 [2] 		



KW/PS



Sierra 1.8L TD Diesel					08/88 → 02/93	188			
RFA/RFB	1753	4	82.50	Indirect Injection		54/75	BT190 (Fibre), 1.36mm, 2 Teeth [4] [30-026353-10] →08/92 -0.43 → 0.68mm	DT193▲ (21-26448-21/0)	ET190 [5] (22-26449-00/0)
RFL	1753	4	82.50	Indirect Injection		55/75	BT200 (Fibre), 1.42mm, 3 Teeth [4] [30-026354-10] →08/92 -0.681 → 0.74mm BT210 (Fibre), 1.52mm, 4 Teeth [4] [30-026355-10] →08/92 -0.741 → 0.86mm BW010 (Fibre), 1.36mm, 2 Notches [30-027536-00] 09/92 → -0.43 → 0.68mm AB5800 (Fibre), 1.36mm, 2 Teeth [4] [30-027530-00] 09/92 → -0.43 → 0.68mm BW020 (Fibre), 1.42mm, 3 Notches [30-027537-00] 09/92 → -0.681 → 0.74mm AB5810 (Fibre), 1.42mm, 3 Teeth [4] [30-027531-00] 09/92 → -0.681 → 0.74mm BW030 (Fibre), 1.52mm, 4 Notches [30-027538-00] 09/92 → -0.741 → 0.86mm AB5820 (Fibre), 1.52mm, 4 Teeth [4] [30-027532-00] 09/92 → -0.741 → 0.86mm		ET191 [6] (22-28438-00/0)
Sierra 2.0L i DOHC					12/91 → 02/93	189			
Sierra 2.0L					07/89 → 12/92				
N8A	1998	4	86.00	Carburettor, DOHC		80/109			
N9E	1998	4	86.00	L-Jetronic, DOHC		85/115			
Sierra 2.0L i DOHC					12/91 → 02/93	190			
N9E	1998	4	86.00	L-Jetronic, DOHC		85/115			
Sierra 2.0L					03/85 → 12/86	191	AH860 (Fibre) [30-025148-10]	CH865 (21-25148-26/0)	EH850 (22-22677-00/0)
Sierra 2.0L i					03/85 → 02/93				
N4B	1993	4	90.80	Efi, SOHC		74/100			
NE5/NEJ/NRD	1993	4	90.80	SOHC		74/100			
N4A/N4I	1993	4	90.80	Efi, SOHC		85/115			
NR2/NRB	1993	4	90.80	Injection		85/115			
Sierra 2.0L					08/82 → 12/86	192	AH860 (Fibre) [30-025148-10]	CH861 →08/83 CH864 (21-25148-40/0)	EH850 (22-22677-00/0)
NET	1993	4	90.80	Injection, DOHC		77/105			

								
HBS007  [22-18085B] →08/92 HBS033  [22-18007B] M12x1.75x136mm (x10) 09/92→	JD240  [31-026450-00] JD310  [31-026847-00]	JN816 [50-026448-10]	JJ456 [6] [50-026449-00] JJ463 [5] [50-028438-00]	HR659  [24-30591-25/0] →08/92 HR801  09/92→	NB785  28x38x7mm, FPM [50-305940-50] NB984  66.67x89.3x10mm, FPM [50-306841-50] NA793  79x95.3x11.1mm, MVQ NC086  [3] 79.8x184x18.8mm, PTFE [50-319517-00]	HL5018 [245]  NB596 [2]  NA585 [2]  NJ004 [2]  NC044 [15]	 AB580, AB5810, AB5820  AH860  BT190, BT200, BT210  BW010, BW020, BW030  JA768  JA769  JA770  JD240  JD310  JE719  JM510  JN620  JN816  HC285  JJ456  JJ463	
				HR655  24-30691-15/0	NB645  35x50x7mm, MVQ NA5190  42x56x7mm, FPM [50-307352-70] NB847  88x108x11mm, FPM [50-307171-70]			
HBS032  [22-18003B] M11x1.50x178mm (x10)				HR655  24-30691-15/0	NB645  35x50x7mm, MVQ NA5190  42x56x7mm, FPM [50-307352-70] NB847  88x108x11mm, FPM [50-307171-70]			
HBS056  [22-18002B] M12x1.75x92.5mm (x10)	JA769  [31-022642-10] JA768  [31-022672-10] JA770  (x3) [31-022671-10]  JE719	JN620 [31-024963-40]	HC285  [23-22677-00/0]	HR631  [24-30612-25/0] HR661  [1] [50-306802-50]	NA5190  (x2) 42x56x7mm, FPM [50-307352-70] NA5190  42x56x7mm, FPM [50-307352-70] NA793  79x95.3x11.1mm, MVQ	NA580 [2]  NB655 [2]  NA585 [2]  KA289 [13] KT738 [14]		
HBS056  [22-18002B] M12x1.75x92.5mm (x10)	JA769  [31-022642-10] JA768  [31-022672-10] JA770  (x3) [31-022671-10]  JE719	JM510 [31-022641-20] →08/83 JN620 [31-024963-40] 09/83→	HC285  [23-22677-00/0]	HR631  [24-30612-25/0] HR661  [1] [50-306802-50]	NA5190  (x2) 42x56x7mm, FPM [50-307352-70] NA5190  42x56x7mm, FPM [50-307352-70] NA793  79x95.3x11.1mm, MVQ	NA580 [2]  NB655 [2]  NA585 [2]  KA289 [13] KT738 [14]		







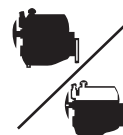



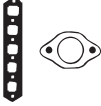

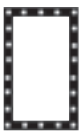

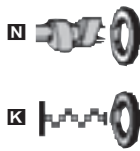







































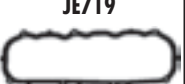

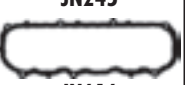





























































FORD



KW/PS



Sierra 2.0L				01/87 → 02/93	193	AH860 (Fibre) (30-025148-10)	CH864 (21-25148-40/0)	EH850 (22-22677-00/0)
NES	1993	4	90.80	Injection, DOHC	77/105			
N8C	1998	4	86.00	DOHC	77/105			
Sierra 2.0L 4x4				05/89 → 02/93	194	BT480 (Fibre) (30-025729-00)	DT482 [20] (21-25729-40/0)	EX550 (22-26643-00/0)
Sierra 2.0L i				05/89 → 02/93		BX550 (MLS) (30-028387-10)	DX550 [21] (21-26709-40/0)	
N8A	1998	4	86.00	Carburettor, DOHC	80/109			
N9C	1998	4	86.00	EFi, DOHC	88-92/ 120- 125			
N9B	1998	4	86.00	Injection, DOHC	92/125			
Sierra RS Cosworth				11/87 → 01/90	195			
N5B	1993	4	90.83	Injection, DOHC	150/204			
Sierra 2.3L				08/82 → 12/86	196	BL080 (Fibre)	DL081	EL080
YYT	2293	6	90.00	Carburettor, V6	84/114	(30-024410-10) BL090 (Fibre) (30-024411-10)		
Sierra 2.3L D Diesel				08/82 → 02/93	197	BP890 (Fibre), 1.53mm, 2 Notches (30-026144-10)	DG050 (21-24586-24/0)	GG050
YTR (XD2/ XD2P/XD94)/YTT (XD2/XD2P/XD94)	2304	4	94.00		49/67	BP900 (Fibre), 1.63mm, 3 Notches (30-026145-10) BP910 (Fibre), 1.73mm, 4 Notches (30-026146-10)		
Sierra 2.8L i				01/87 → 02/93	198	BL400 (Fibre)	DL401 [31]	
Sierra 2.8L i 4x4				01/87 → 02/93		(30-025150-10)	DL402 [32]	
Sierra 2.8L i XR 4x4				01/87 → 02/93		BL410 (Fibre)		
PR8	2792	6	93.00	EFi, V6	105- 107/ 143- 145			
PR7	2792	6	93.00	EFi, V6	107/146			
PRG	2792	6	93.00	Injection, V6	110/150			
Sierra 2.8L i				08/82 → 12/86	199	BL400 (Fibre)	DL401 [31]	
Sierra 2.8L i XR				09/83 → 12/86		(30-025150-10)	DL402 [32]	
Sierra 2.8L XR				02/85 → 12/86		BL410 (Fibre)		
Sierra 2.8L XR4i				08/82 → 12/86				
PR6	2792	6	93.00		105/143			
PR6	2792	6	93.00	EFi, V6	105/143			
PR5	2792	6	93.00		107/146			
PR5	2792	6	93.00	EFi, V6	107/146			
PRT	2792	6	93.00	Injection, V6	110/150			
Sierra 2.9L				08/88 → 02/93	200	BT510 (Fibre)	DT510 (21-26027-21/0)	ET490 (22-25667-02/0)
Sierra 2.9L 4x4				08/88 → 02/93		(30-026081-00)		GT510
Sierra 2.9L i				08/88 → 02/93		BT520 (Fibre)		
Sierra 2.9L i XR 4x4				08/88 → 02/93		(30-026080-00)		
B4A/B4B/B4C	2935	6	93.00	EFi, V6	143/ 152/ 195/ 207			

									
HBS056  (22-18002B) M12x1.75x92.5mm (x10)	JA769  (31-022642-10) JA768  (31-022672-10) JA770  (x3) (31-022671-10)  JE719	JN620 (31-024963-40)	HC285  (23-22677-00/0)	HR631  (24-30612-25/0) HR661  [1] (50-306802-50)	 NA5190  (x2) 42x56x7mm, FPM (50-307352-70)  NA5190  42x56x7mm, FPM (50-307352-70)  NA793  79x95.3x11.1mm, MVQ	NA580 [2]  NB655 [2]  NA585 [2]  KA289 [13] KI738 [14]		 AH860  BL080  BL090  BL400  BL410  BP890, BP900, BP910  BT480  BT510  BT520  BX550  JA768  JA769  JA770  JB842  JC363  JC364  JC365	 JD5268  JD542  JD543  JE5020  JE719  JM875  JN245  JN616  JN620  JN662  JN817  HC285  JJ457  JJ458
HBS032  (22-18003B) M11x1.50x178mm (x10)	JD542  (x2) (31-026711-00) JD543  (x2) (31-026640-00)	JN817 (50-026709-00)	JJ457 (50-026643-00)	HR655  24-30691-15/0	 NB645  35x50x7mm, MVQ  NA5190  42x56x7mm, FPM (50-307352-70)  NB847  88x108x11mm, FPM (50-307171-70)	NB596 [2]  NB655 [2] 			
HBS056  (22-18002B) M12x1.75x92.5mm (x10)									
	JC363  (31-024454-10) JC365  (x6) (32-206600-10)	JM875 (x2) (31-021055-10)	HC418  (23-21053-01/0)	HR633  (x2) (50-022425-10)	 NA5190  42x56x7mm, FPM (50-307352-70)  NB564  60.5x76.2x10mm, FPM (50-307219-70)	NA580 [2]  NA585 [2] 			
HBS015  (22-53004B) M11x1.50x97.5mm (x8) M11x1.50x120mm (x7) M11x1.50x107.5mm (x7)	JB842  (x2)	JN245 (50-024586-00)	PA349 (33-102290-10) 22x16x2mm		 NF387  42x60x10mm, NBR (50-306429-00)  KS696 (x2) (31-025367-10)				
	JC364  (31-024452-10) JC365  (x6) (32-206600-10)	JM875 (x2) [31] (31-021055-10) JN616 (x2) [32] (31-021055-30)	JJ458 (50-025667-00)	HR633   (50-022425-10) HR630  	 NA5190  42x56x7mm, FPM (50-307352-70)  NB564  60.5x76.2x10mm, FPM (50-307219-70)	NA580 [2]  NA585 [2] 			
	JC364  (31-024452-10) JC365  (x6) (32-206600-10)	JM875 (x2) [31] (31-021055-10) JN616 (x2) [32] (31-021055-30)	HC418  (23-21053-01/0) →08/85 JJ458 (50-025667-00) 09/85 →	HR633   (50-022425-10) HR630  	 NA5190  42x56x7mm, FPM (50-307352-70)  NB564  60.5x76.2x10mm, FPM (50-307219-70)	NA580 [2]  NA585 [2] 			
HBS057  (22-18004B) M12x1.75x87mm (x16) HBS140  (22-18088B) M12x1.75x115mm (x16)	JD5268  (31-026083-00) JE5020  (x6) (31-026084-00)	JN662 (x2) (31-026027-00)	JJ458 (50-025667-00)	HR660 	 NA5190  42x56x7mm, FPM (50-307352-70)  NA5190  42x56x7mm, FPM (50-307352-70)  NB564  60.5x76.2x10mm, FPM (50-307219-70)	NB596 [2] 			

FORD



KW/PS

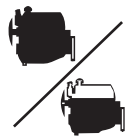

S-Max 2.0L TDCi Diesel				05/06 →	201	AD5490 (MLS), 1.25mm (30-029789-00) AD5500 (MLS), 1.30mm (30-029790-00) AD5510 (MLS), 1.35mm (30-029791-00) AD5520 (MLS), 1.40mm (30-029792-00)	CD5500▲	ED5500
AZWA/QXWA/QXWB	1997	4	85.00	Direct Injection, DOHC				
S-Max 2.5L ST				05/06 →	202	AG8320 (MLS) (30-029272-00)		
HUWA	2521	5	83.00	Injection, DOHC				
Tourneo Connect 1.8L 16V				06/02 →	203	AC5800 (MLS) (30-029400-00)	CC5801 (21-29400-21/0) 09/02 →	EC5800 (22-29400-00/0)
EYPA/EYPC	1796	4	80.60	Injection, DOHC	85/116			
Tourneo Connect 1.8L Di Diesel				06/02 →	204	AB5300 (MLS), 1.27mm, 2 Teeth (30-029242-00) AB5310 (MLS), 1.32mm, 3 Teeth (30-029243-00) AB5320 (MLS), 1.37mm, 4 Teeth (30-029244-00) AB5330 (MLS), 1.42mm, 5 Teeth (30-029245-00) AB5340 (MLS), 1.47mm, 6 Teeth (30-029246-00) AB5350 (MLS), 1.52mm, 7 Teeth (30-029247-00)	DZ720▲ (21-29180-20/0)	EZ720 (22-29485-00/0)
Tourneo Connect 1.8L Turbo Di Diesel				06/02 →				
HCPA/HCPB	1753	4	82.50	TDCi, SOHC	66/89			
BHPA	1753	4	82.50	Direct Injection, SOHC				
Transit 1.6L				12/77 →10/86	205	AH850 (Fibre) (30-022666-20)	CH851 (21-22641-20/0) →08/83 CH854 09/83 →	EH850 (22-22677-00/0)
4RB	1593	4	87.65	SOHC	46/63			
Transit 1.6L				09/85 →09/92	206	AH850 (Fibre) (30-022666-20)	CH854	EH850 (22-22677-00/0)
LAT	1594	4	87.65	SOHC	46-48/ 63-65			
Transit 2.0L				11/77 →10/86	207	AH860 (Fibre) (30-025148-10)	CH864 (21-25148-40/0) CH861 01/78 →08/83	EH850 (22-22677-00/0)
4RC	1993	4	90.80	Carburettor, SOHC	43-57/ 59-78			
Transit 2.0L				09/85 →09/92	208	AH860 (Fibre) (30-025148-10)	CH861 →08/83 CH864 (21-25148-40/0)	EH850 (22-22677-00/0)
NAV	1993	4	90.80	Carburettor, SOHC	55-57/ 75-78			
NAT	1993	4	90.80	Carburettor, SOHC	57/77			
Transit 2.0L				11/85 →09/92	209	AH860 (Fibre) (30-025148-10)	CH864 (21-25148-40/0)	EH850 (22-22677-00/0)
N6T	1993	4	90.80		57/77			

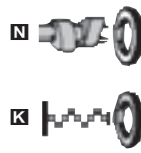
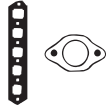

AB5300, AB5310,
AB5320, AB5330,
AB5340, AB5350



AC5800



AD5490, AD5500,
AD5510, AD5520



AH850, AH860



JA768



JA769



JA770



JD309



JD310



JD5312



JD5313



JM5016



JM510

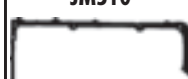

JN620



HC285



JH5061



JH5061



KWPS

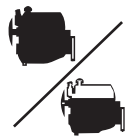

Transit 2.0L		06/94 → 03/00		210		AC5910 (MLS), 1.60mm (30-029401-00)	
NSF/NSG	1998	4	86.00	DOHC	84/114		
Transit 2.0L		09/91 → 09/94		211		AH860 (Fibre) (30-025148-10)	
Transit 2.0L i		09/91 → 07/94				CH865 (21-25148-26/0)	
NBA	1993	4	90.80	Carburettor, SOHC	66/89		EH850 (22-22677-00/0)
NCA	1994	4	90.80	Injection, SOHC	72/98		
Transit 2.0L CNG		06/94 → 03/00		212		BX550 (MLS) (30-028387-10)	
NSH	1998	4	86.00	SPi, DOHC	74-84/ 101- 114		
Transit 2.0L DI Diesel		08/00 →		213		AA5970 (MLS), 1.10mm, 1 Hole (30-029424-00)	
ABFA/D3FA	1998	4	86.00	Direct Injection	55/75		CA5970▲ (21-29447-20/0)
F3FA	1998	4	86.00		63/86		→ 05/02 EA5970 (22-29508-00/0)
Transit 2.0L TDCi Diesel		08/02 →		214		AA5970 (MLS), 1.10mm, 1 Hole (30-029424-00)	
FIFA	1998	4	86.00		92/125		EA5970 (22-29508-00/0)
Transit 2.3L 16V		07/06 →		215		AD5220 (MLS) (30-029824-00)	
GZFA	2295	4		Injection, DOHC	107- 100/ 145- 136		
Transit 2.3L 16V		04/01 →		216		CC5680	
E5FA	2295	4	89.60	SPi	107/146		
E5FC	2295	4	89.60	SPi, DOHC			
Transit 2.4L D Diesel		11/77 → 10/86		217		AX270 (Fibre)	
4AA	2358	4	93.67		46/62		CX270■ EX270 FX270○
Transit 2.4L DI Diesel		01/00 →		218		AA5940 (MLS), 1.10mm, 1 Hole (30-029421-00)	
F4FA	2402	4	89.90	Direct Injection, DOHC	55/75		CA5940▲ (21-29490-20/0)
D2FA/D2FB	2402	4	89.90	Direct Injection	66/89		EA5940 (22-29508-01/0)
D4FA	2402	4	89.90	Direct Injection, DOHC	88/120		
D2FB	2402	4	89.90	Direct Injection, DOHC			
Transit 2.4L TDCi Diesel		03/04 →		219		AA5940 (MLS), 1.10mm, 1 Hole (30-029421-00)	
Transit 2.4L TDE Diesel		07/01 →					
FXFA	2402	4	89.90		85/115		EA5940 (22-29508-01/0)
DOFA	2402	4	89.90		92/125		
H9FA	2402	4	89.90		101/137		
Transit 2.5L D Diesel		10/83 → 10/86		220		BT800 (Fibre)	
4AB	2496	4	93.67	Direct Injection	50-52/ 68-71		DT800▲ (21-28952-20/0)











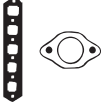

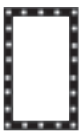

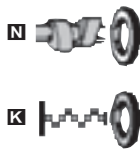



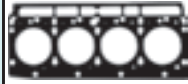

HBS032 [22-18003B] M11x1.50x178mm (x10)	JD542 (x2) (31-026711-00) JD543 (x2) (31-026640-00)		JJ457 (50-026643-00)	HR655 24-30691-15/0	NB645 35x50x7mm, MVQ NA5190 42x56x7mm, FPM (50-307352-70) NB847 88x108x11mm, FPM (50-307171-70)		 AA5940, AA5950, AA5960 JM5037 JN106 JN460
HBS056 [22-18002B] M12x1.75x92.5mm (x10)	JA769 (x2) (31-022642-10) JA768 (31-022672-10) JA770 (x3) (31-022671-10) 	JN620 (31-024963-40)	HC285 (23-22677-00/0)	HR631 (24-30612-25/0) HR661 [1] (50-306802-50)	NA5190 42x56x7mm, FPM (50-307352-70) NA5190 42x56x7mm, FPM (50-307352-70) NA793 79x95.3x11.1mm, MVQ		 AA5970, AA5980, AA5990 JN620 AC5910 HC285
HBS032 [22-18003B] M11x1.50x178mm (x10)				HR655 24-30691-15/0	NB645 35x50x7mm, MVQ NA5190 42x56x7mm, FPM (50-307352-70) NB847 88x108x11mm, FPM (50-307171-70)		 AD5220 HC326
HBS296 [22-18011B] M10x1.50x159mm (x10)	HA5020 [1] [2] (24-29876-00/0) JA5085 →05/02	JM5037 (50-029447-00)	HC5004 (24-29508-00/0)	HR5082 (24-31950-70/0)	NA5028 36x50x7mm, PTFE (50-319486-00) NA5031 50x86.5x13.7mm, PTFE (50-319457-00) NA5030 [3] 106x190x15.2mm, FPM (50-319487-00)		 AH860 HC451 AX270
HBS296 [22-18011B] M10x1.50x159mm (x10)	HA5020 [1] [2] (24-29876-00/0)	JM5037 (50-029447-00)	HC5004 (24-29508-00/0)	HR5082 (24-31950-70/0)	NA5028 36x50x7mm, PTFE (50-319486-00) NA5031 50x86.5x13.7mm, PTFE (50-319457-00) NA5030 [3] 106x190x15.2mm, FPM (50-319487-00)		 BT800 HC5004 JJ457
HBS369 [22-18095B] M10x1.50x145.5mm (x10)							 BX550 JA5085 JA768 JA769 JA770
HBS032 [22-18003B] M11x1.50x178mm (x10)		HM5238		HR655 (x2) 24-30691-15/0	NA5177 42x56x7mm, FPM (50-319189-00)		 JA768 JA769 JA770
HBS008 [22-18005B] M12x1.75x92mm (x18)		JN106	HC326		NB453 47.6x67x11.1mm, MVQ NB452 66.7x85.7x9.52mm, MVQ NA793 79x95.3x11.1mm, MVQ		 JA770 JD064 JD542
HBS296 [22-18011B] M10x1.50x159mm (x10)	HA5020 [1] [2] (24-29876-00/0) JA5085	JM5037 (50-029447-00)	HC5004 (24-29508-00/0)	HR5082 (24-31950-70/0)	NA5031 50x86.5x13.7mm, PTFE (50-319457-00) NA5030 [3] 106x190x15.2mm, FPM (50-319487-00)		 JD542 JD543 JE719
HBS008 [22-18005B] M12x1.75x92mm (x18)	JD064	JN460 (31-028954-00)	HC451	HR5064 (24-31935-10/0)	NB788 79.4x95.3x11.1mm, PTFE (50-306413-50)		



KW/PS



Transit 2.5L D Diesel					12/85 → 09/91	221	BT800 (Fibre)	DT800▲ (21-28952-20/0) → 08/89 DT803■ (21-28952-22/0) → 08/89 DT802 [24] 08/89 → DT806 [25] (21-28952-21/0) 08/89 →	EN260 → 09/88 ET800 (22-28953-00/0) 10/88 →
4AB	2496	4	93.67	Direct Injection	50-52/ 68-71				
Transit 2.5L D Diesel					09/88 → 09/92	222	BT800 (Fibre)	DT802 [24] DT806 [25] (21-28952-21/0)	ET800 (22-28953-00/0)
Transit 2.5L DI Diesel					09/88 → 09/92				
4AB	2496	4	93.67	Direct Injection	50-52/ 68-71				
4BA/4CA	2496	4	93.67	Direct Injection	52/71				
Transit 2.5L D Diesel					10/83 → 10/86	223	BT800 (Fibre)	DT800▲ (21-28952-20/0) DT803■ (21-28952-22/0)	EN260 → 09/88 ET800 [27] (22-28953-00/0) 10/88 →
4AB	2496	4	93.67	Direct Injection	50-52/ 68-71				
Transit 2.5L DI Diesel					05/91 → 03/00	224	BT800 (Fibre)	DT802 DT806 [25] (21-28952-21/0)	ET800 (22-28953-00/0)
4FD	2496	4	93.67	Direct Injection	51/69				
4FB/4FC	2496	4	93.67	Direct Injection	51/70				
4FA	2496	4	93.67	Direct Injection	51-52/ 69-70				
4BC/4CC	2496	4	93.67	Direct Injection	52/71				
Transit 2.5L DI Diesel					05/91 → 03/00	225	BT800 (Fibre)	DT806 [25] (21-28952-21/0)	ET800 (22-28953-00/0)
4HB/4HC	2496	4	93.67	Direct Injection	56/76				
4DA	2496	4	93.67	Direct Injection	59/80				
Transit 2.5L DI Diesel					10/92 → 03/00	226	BT800 (Fibre)	DT801 [24] DT805 [25] (21-28952-23/0)	ET800 [6] (22-28953-00/0)
Transit 2.5L TD Diesel					05/91 → 06/00				
Transit 2.5L TDI Diesel					06/94 → 03/00				
4HA/4HD	2496	4	93.67	Direct Injection	55/75				
4GA/4GB/4GC/4GF	2496	4	93.67	Direct Injection	63/85				
4GD/4GE	2496	4	93.67	Direct Injection	63/86				
4EA/4EB/4EC	2496	4	93.67	Direct Injection	74/100				
4ED	2496	4	93.67	Direct Injection	85/116				
Transit 2.9L i					01/91 →	227	BT510 (Fibre) ◀ (30-026081-00) BT520 (Fibre) ▶ (30-026080-00)	DT510 (21-26027-21/0)	ET490 (22-25667-02/0) GT510
BRT	2935	6	93.00	Injection	104- 107/ 141- 145				

								
HBS008 (22-18005B) M12x1.75x92mm (x18)	JD064	JN460 (31-028954-00) →07/89 JM5027 (31-029026-00) (Rubber/Metal) 08/89→ JN821 [26] (Cork) 08/89→	HC451 →09/88 JJ484 (50-028953-00) 10/88→	HR5064 (24-31935-10/0)	<input checked="" type="checkbox"/> NB856 47.62x66.5x11mm, PTFE (50-319371-00) 10/88→ <input checked="" type="checkbox"/> NB788 79.4x95.3x11.1mm, PTFE (50-306413-50) →09/88 <input checked="" type="checkbox"/> NB855 67x86x9.5mm, PTFE (50-319375-00) 10/88→ <input checked="" type="checkbox"/> NB854 79x99x10mm, PTFE (50-319376-00) 10/88→			 BT510  BT520  BT800  JD064  JD065  JD066  JD5268  JE5020  JM5027  JN460  JN662  JN821  HC451  JJ458  JJ484
HBS008 (22-18005B) M12x1.75x92mm (x18)	JD064	JN460 (31-028954-00) →07/89 JM5027 (31-029026-00) (Rubber/Metal) 08/89→ JN821 [26] (Cork) 08/89→	JJ484 (50-028953-00)	HR5064 (24-31935-10/0)	<input checked="" type="checkbox"/> NB856 47.62x66.5x11mm, PTFE (50-319371-00) <input checked="" type="checkbox"/> NB855 67x86x9.5mm, PTFE (50-319375-00) <input checked="" type="checkbox"/> NB854 79x99x10mm, PTFE (50-319376-00)			
HBS008 (22-18005B) M12x1.75x92mm (x18)	JD064	JN460 (31-028954-00)	HC451	HR5064 (24-31935-10/0)	<input checked="" type="checkbox"/> NB788 79.4x95.3x11.1mm, PTFE (50-306413-50)			
HBS008 (22-18005B) M12x1.75x92mm (x18)	JD064 JD066 (31-029616-00)	JM5027 (31-029026-00) (Rubber/Metal) JN821 [26] (Cork)	JJ484 (50-028953-00)	HR5064 (24-31935-10/0)	<input checked="" type="checkbox"/> NB856 47.62x66.5x11mm, PTFE (50-319371-00) <input checked="" type="checkbox"/> NB855 67x86x9.5mm, PTFE (50-319375-00) <input checked="" type="checkbox"/> NB854 79x99x10mm, PTFE (50-319376-00)			
HBS008 (22-18005B) M12x1.75x92mm (x18)	JD064 JD066 (31-029616-00)	JM5027 (31-029026-00) (Rubber/Metal)	JJ484 (50-028953-00)	HR5064 (24-31935-10/0)	<input checked="" type="checkbox"/> NB856 47.62x66.5x11mm, PTFE (50-319371-00) <input checked="" type="checkbox"/> NB855 67x86x9.5mm, PTFE (50-319375-00) <input checked="" type="checkbox"/> NB854 79x99x10mm, PTFE (50-319376-00)			
HBS008 (22-18005B) M12x1.75x92mm (x18)	JD065 JD066 (31-029616-00)	JM5027 (31-029026-00) (Rubber/Metal) JN821 [26] (Cork)	JJ484 (50-028953-00)	HR5064 (24-31935-10/0)	<input checked="" type="checkbox"/> NB856 47.62x66.5x11mm, PTFE (50-319371-00) <input checked="" type="checkbox"/> NB855 67x86x9.5mm, PTFE (50-319375-00) <input checked="" type="checkbox"/> NB854 79x99x10mm, PTFE (50-319376-00)			
HBS057 (22-18004B) M12x1.75x87mm (x16) HBS140 (22-18088B) M12x1.75x115mm (x16)	JD5268 (31-026083-00) JE5020 (x6) (31-026084-00)	JN662 (x2) (31-026027-00)	JJ458 (50-025667-00)	HR660	<input checked="" type="checkbox"/> NA5190 42x56x7mm, FPM (50-307352-70) <input checked="" type="checkbox"/> NB564 60.5x76.2x10mm, FPM (50-307219-70)	NB596 [2]		

FORD











KW/PS



Transit Connect 1.8L 16V				06/02 →	228	AC5800 (MLS) (30-029400-00)	CC5801 (21-29400-21/0) 09/02 →	EC5800 (22-29400-00/0)
EYPA	1796	4	80.60		85/116			
Transit Connect 1.8L Di Diesel				06/02 →	229	AB5300 (MLS), 1.27mm, 2 Teeth (30-029242-00)	DZ720▲ (21-29180-20/0)	EZ720 (22-29485-00/0)
Transit Connect 1.8L TDCi Diesel				06/02 →				
BHPA	1753	4	82.50		55/75	AB5310 (MLS), 1.32mm, 3 Teeth (30-029243-00)		
HCPA, HCPB	1753	4	82.50		66/90	AB5320 (MLS), 1.37mm, 4 Teeth (30-029244-00)		
						AB5330 (MLS), 1.42mm, 5 Teeth (30-029245-00)		
						AB5340 (MLS), 1.47mm, 6 Teeth (30-029246-00)		
						AB5350 (MLS), 1.52mm, 7 Teeth (30-029247-00)		

HBS031 [22-18008B] M10x1.50x102mm (x10)	JD5312 (x4) (50-029873-00) 09/02→ JD5313 (50-029874-00)	JM5184 (50-029871-00) Light Blue	JH5061 (50-029586-00)	HR5033 (24-30715-70/0)	NB958 (x2) 42x53x7mm, FPM (50-319323-00) NB959 35x50x7mm, FPM (50-306644-50) NB847 88x108x11mm, FPM (50-307171-70)	 AC5800 JD309 JD310 JD5312 JD5313 JM5016	AB5300, AB5310, AB5320, AB5330, AB5340, AB5350 JH5061
HBS243 [22-18089B] M12x1.75x137mm (x2) M12x1.75x177mm (x8)	JD309 (31-026846-00) JD310 (31-026847-00)	JM5016 (50-029180-00)	JH5008 (50-029485-00)	HR801	NB785 28x38x7mm, FPM (50-305940-50) NA5013 30x50x7.5mm, PTFE (50-319466-00) NC086 [3] 79.8x184x18.8mm, PTFE (50-319517-00)	 JM5016	

		CC			9			CC			9
20T2N	Diesel	1994	4	84.45	5	D15Z1	Petrol	1493	4	75.00	48
20T2N	Diesel	1994	4	84.45	85	D15Z1	Petrol	1493	4	75.00	56
20T2R	Diesel	1994	4	84.50	85	D15Z1	Petrol	1493	4	75.00	59
4EE-2	Diesel	1686	4	79.00	82	D15Z1	Petrol	1493	4	75.00	99
A20A1	Petrol	1955	4	82.70	156	D15Z3	Petrol	1493	4	75.00	48
A20A1	Petrol	1955	4	82.70	9	D15Z3	Petrol	1493	4	75.00	57
A20A2	Petrol	1955	4	82.70	9	D15Z6	Petrol	1493	4	75.00	53
A20A3	Petrol	1955	4	82.70	10	D15Z8	Petrol	1493	4	75.00	50
A20A4	Petrol	1955	4	82.70	10	D16A	Petrol	1590	4	75.00	105
A20A4	Petrol	1955	4	82.70	136	D16A6	Petrol	1590	4	75.00	105
B16A1	Petrol	1595	4	81.00	108	D16A6	Petrol	1590	4	75.00	69
B16A1	Petrol	1595	4	81.00	73	D16A7	Petrol	1590	4	75.00	31
B16A2	Petrol	1595	4	81.00	104	D16A7	Petrol	1590	4	75.00	65
B16A2	Petrol	1595	4	81.00	61	D16A7	Petrol	1590	4	75.00	72
B16A2	Petrol	1595	4	81.00	76	D16A7	Petrol	1590	4	75.00	89
B18	Petrol	1834	4	81.00	132	D16A8	Petrol	1590	4	75.00	90
B18A	Petrol	1834	4	81.00	119	D16A9	Petrol	1590	4	75.00	107
B18A	Petrol	1834	4	81.00	134	D16A9	Petrol	1590	4	75.00	71
B18C4	Petrol	1797	4	81.00	83	D16A9	Petrol	1590	4	75.00	72
B18C6	Petrol	1797	4	81.00	120	D16A9	Petrol	1590	4	75.00	91
B20A2	Petrol	1958	4	81.00	12	D16B2	Petrol	1590	4	75.00	64
B20A3	Petrol	1958	4	81.00	137	D16B6	Petrol	1590	4	75.00	2
B20A4	Petrol	1958	4	81.00	137	D16V1	Petrol	1590	4	75.00	62
B20A5	Petrol	1958	4	81.00	140	D16V1	Petrol	1590	4	75.00	88
B20A7	Petrol	1958	4	81.00	139	D16W1	Petrol	1590	4	75.00	114
B20A8	Petrol	1958	4	81.00	12	D16Y2	Petrol	1590	4	75.00	60
B20A9	Petrol	1958	4	81.00	139	D16Y2	Petrol	1590	4	75.00	75
B20B	Petrol	1973	4	84.00	95	D16Y3	Petrol	1590	4	75.00	67
B20Z1	Petrol	1973	4	84.00	94	D16Y5	Petrol	1590	4	75.00	68
C25A1	Petrol	2494	6	84.00	124	D16Y6	Petrol	1590	4	75.00	74
C25A2	Petrol	2494	6	84.00	124	D16Y6	Petrol	1590	4	75.00	79
C27A1	Petrol	2675	6	87.00	125	D16Y7	Petrol	1590	4	75.00	77
C30A3	Petrol	2977	6	90.00	128	D16Y7	Petrol	1590	4	75.00	78
C30A4	Petrol	2977	6	90.00	129	D16Y8	Petrol	1590	4	75.00	102
C32A2	Petrol	3206	6	90.00	126	D16Y8	Petrol	1590	4	75.00	74
C32B2	Petrol	3179	6	93.00	130	D16Y8	Petrol	1590	4	75.00	78
D12B1	Petrol	1187	4	74.00	35	D16Z2	Petrol	1590	4	75.00	109
D13B1	Petrol	1343	4	75.00	38	D16Z2	Petrol	1590	4	75.00	70
D13B2	Petrol	1343	4	75.00	39	D16Z2	Petrol	1590	4	75.00	88
D13B2	Petrol	1343	4	75.00	40	D16Z5	Petrol	1590	4	75.00	103
D13B2	Petrol	1343	4	75.00	41	D16Z6	Petrol	1590	4	75.00	102
D13B7	Petrol	1343	4	75.00	127	D16Z6	Petrol	1590	4	75.00	60
D14A1	Petrol	1396	4	75.00	45	D16Z6	Petrol	1590	4	75.00	66
D14A1	Petrol	1396	4	75.00	86	D16Z7	Petrol	1590	4	75.00	60
D14A1	Petrol	1396	4	75.00	97	D16Z7	Petrol	1590	4	75.00	66
D14A2	Petrol	1396	4	75.00	44	D16Z9	Petrol	1590	4	75.00	79
D14A3	Petrol	1396	4	75.00	43	D17A2	Petrol	1668	4	75.00	153
D14A4	Petrol	1396	4	75.00	43	D17A5	Petrol	1668	4	75.00	81
D14A4	Petrol	1396	4	75.00	45	D17A6	Petrol	1668	4	75.00	80
D14A5	Petrol	1396	4	75.00	44	D17A8	Petrol	1668	4	75.00	80
D14A7	Petrol	1396	4	75.00	43	D17A9	Petrol	1668	4	75.00	81
D14A7	Petrol	1396	4	75.00	47	ECA1	Petrol	995	3	72.00	115
D14A8	Petrol	1396	4	75.00	43	ECA1	Petrol	995	3	72.00	116
D14A8	Petrol	1396	4	75.00	86	EH	Petrol	545	2	72.00	28
D14Z1	Petrol	1396	4	75.00	43	EL	Petrol	1602	4	77.00	146
D14Z2	Petrol	1396	4	75.00	43	EP	Petrol	1602	4	77.00	131
D14Z5	Petrol	1396	4	75.00	42	EP	Petrol	1602	4	77.00	145
D14Z6	Petrol	1396	4	75.00	42	ER	Petrol	1231	4	66.00	32
D15B2	Petrol	1493	4	75.00	48	ES	Petrol	1829	4	80.00	133
D15B2	Petrol	1493	4	75.00	54	ET	Petrol	1829	4	80.00	135
D15B2	Petrol	1493	4	75.00	55	EV2	Petrol	1342	4	74.00	148
D15B2	Petrol	1493	4	75.00	56	EV2	Petrol	1342	4	74.00	37
D15B2	Petrol	1493	4	75.00	59	EV2	Petrol	1342	4	74.00	96
D15B2	Petrol	1493	4	75.00	87	EW1	Petrol	1488	4	74.00	117
D15B2	Petrol	1493	4	75.00	98	EW1	Petrol	1488	4	74.00	29
D15B7	Petrol	1493	4	75.00	100	EW1	Petrol	1488	4	74.00	51
D15B7	Petrol	1493	4	75.00	34	EW2	Petrol	1488	4	74.00	49
D15B7	Petrol	1493	4	75.00	48	EW3	Petrol	1488	4	74.00	101
D15B7	Petrol	1493	4	75.00	58	EW3	Petrol	1488	4	74.00	30



CC



9



CC



9







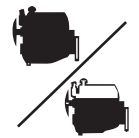



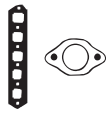

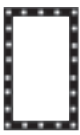

































































































EW3	Petrol	1488	4	74.00	52
EW4	Petrol	1488	4	74.00	30
EW4	Petrol	1488	4	74.00	52
EY	Petrol	1598	4	80.00	1
F18A3	Petrol	1850	4	85.00	4
F18B2	Petrol	1850	4	85.00	3
F20A2	Petrol	1997	4	85.00	8
F20A3	Petrol	1997	4	85.00	8
F20A4	Petrol	1997	4	85.00	138
F20A4	Petrol	1997	4	85.00	8
F20A6	Petrol	1997	4	85.00	8
F20A7	Petrol	1997	4	85.00	17
F20A8	Petrol	1997	4	85.00	8
F20B3	Petrol	1997	4	85.00	15
F20B5	Petrol	1997	4	85.00	16
F20B6	Petrol	1997	4	85.00	7
F20B7	Petrol	1997	4	85.00	16
F20C VTEC	Petrol	1997	4	87.00	147
F20Z1	Petrol	1997	4	85.00	13
F20Z1	Petrol	1997	4	85.00	14
F20Z2	Petrol	1997	4	85.00	11
F20Z2	Petrol	1997	4	85.00	155
F20Z3	Petrol	1997	4	85.00	13
F22A	Petrol	2156	4	85.00	18
F22A3	Petrol	2156	4	85.00	18
F22A7	Petrol	2156	4	85.00	21
F22A8	Petrol	2156	4	85.00	18
F22B5	Petrol	2156	4	85.00	22
F22B8	Petrol	2156	4	85.00	149
F22Z2	Petrol	2156	4	85.00	19
F23A7	Petrol	2254	4	86.00	150
F23A7	Petrol	2254	4	86.00	23
F23Z5	Petrol	2254	4	86.00	24
H22A2	Petrol	2157	4	87.00	142
H22A5	Petrol	2157	4	87.00	141
H22A7	Petrol	2157	4	87.00	20
H23A2	Petrol	2259	4	87.00	143
H23A3	Petrol	2259	4	87.00	25
J30A1	Petrol	2997	6	86.00	27
K20A	Petrol	1998	4	86.00	154
K20A	Petrol	1998	4	86.00	6
K20A2	Petrol	1998	4	86.00	121
K20A2	Petrol	1998	4	86.00	84
K20A3	Petrol	1998	4	86.00	121
K20A3	Petrol	1998	4	86.00	84
K20A4	Petrol	1998	4	86.00	93
K20A6	Petrol	1998	4	86.00	152
K20A9	Petrol	1998	4	86.00	110
K20A9	Petrol	1998	4	86.00	113
K20A9	Petrol	1998	4	86.00	151
K24A	Petrol	2354	4	87.00	26
L12A	Petrol	1243	4	73.00	36
L12A1	Petrol	1243	4	73.00	122
L12A1	Petrol	1243	4	73.00	36
L13A1	Petrol	1339	4	73.00	111
L13A1	Petrol	1339	4	73.00	112
L13A1	Petrol	1339	4	73.00	123
L13A1	Petrol	1339	4	73.00	33
XUD7T	Diesel	1769	4	80.00	92
ZA2	Petrol	1187	4	74.00	35
ZC	Petrol	1590	4	75.00	118
ZC	Petrol	1590	4	75.00	144
ZC	Petrol	1590	4	75.00	63
ZC1	Petrol	1590	4	75.00	106



KW/PS



Accord 1.6L 12v 06/83 → 10/86 1						BL360 (Graphite) BM920 (Graphite) (30-026713-10) 01/84 →	DL361 → 01/84 DM921 02/84 →	
EY	1598	4	80.00	SOHC	69/93			
Accord 1.6L i 10/98 → 12/02 2								
D16B6	1590	4	75.00	Injection, SOHC	85/116			
Accord 1.8L i 10/98 → 12/02 3						BV830 (MLS)		
F18B2	1850	4	85.00	Injection, SOHC	100/136			
Accord 1.9L 16V 01/93 → 12/94 4						BS700 (MLS) (30-028118-00)	DS700 (21-28118-20/0)	
Accord 1.9L i 02/96 → 10/98								
F18A3	1850	4	85.00		100/136			
Accord 2.0L Tdi Diesel 04/96 → 10/00 5						BZ440 (MLS), 1.05mm, 1 Hole (30-029569-00) BZ450 (MLS), 1.20mm, 2 Holes (30-029570-00) BZ460 (MLS), 1.35mm, 3 Holes (30-029571-00)	DZ440 ▲ (21-29569-20/0)	EZ440 [12] (22-29569-00/0)
Accord 2.0L Turbo DI Diesel 02/99 → 12/02								
20T2N	1994	4	84.45	Direct Injection, SOHC	77/105			
Accord 2.0L 02/03 → 6							CG5811	EG5810
Accord 2.0L All-wheel Drive 02/03 →								
K20A	1998	4	86.00	DOHC	114- 115/ 155- 156			
Accord 2.0L 12/99 → 12/02 7						BV830 (MLS)		
Accord 2.0L i 10/98 → 01/01								
F20B6	1997	4	85.00	Injection, SOHC	108/147			
Accord 2.0L 16V 01/90 → 03/93 8						BS700 (MLS) (30-028118-00)	DS700 (21-28118-20/0)	
Accord 2.0L i 16V 01/90 → 03/93								
F20A6	1997	4	85.00		66/89			
F20A2	1997	4	85.00	SOHC	81/110			
F20A3	1997	4	85.00		81/110			
F20A4	1997	4	85.00	Injection, SOHC	98/133			
F20A8	1997	4	85.00	Injection	98/133			
Accord 2.0L EX 11/85 → 12/89 9						BN450 (Graphite) (30-028115-00)	DN450	GN450
Accord Aerodeck 2.0L EX 11/85 → 12/89								
A20A1	1955	4	82.70	SOHC	75/102			
A20A2	1955	4	82.70	SOHC	78/106			
Accord 2.0L EXi 11/85 → 12/89 10						BN450 (Graphite) (30-028115-00)	DN451 01/88 →	GN451 01/88 →
Accord Aerodeck 2.0L EXi 11/85 → 12/89								
A20A3	1955	4	82.70	Injection, SOHC	85/116			
A20A4	1955	4	82.70	Injection, SOHC	90/122			
Accord 2.0L i 03/93 → 01/96 11						BS700 (MLS) (30-028118-00)	DS705	
F20Z2	1997	4	85.00	Injection, SOHC	85/116			
Accord 2.0L i 16V 01/87 → 12/89 12						BS110 (Graphite)	DS111	
B20A8	1958	4	81.00	Injection, DOHC	98/133			
B20A2	1958	4	81.00	Injection, DOHC	101/137			
Accord 2.0L i 16V 03/93 → 12/93 13						BS700 (MLS) (30-028118-00)	DS705	
Accord 2.0L i S 03/93 → 01/96								
F20Z1	1997	4	85.00	Injection, SOHC	96/131			
F20Z3	1997	4	85.00	Injection	98/133			

								
		JC404  JC405  (x2)	JN605 (50-028111-00)	JJ271	PA286 (x4) PA531  (x8) PA288  (x4)	 NJ313 29x45x8mm, ACM  NJ311  35x54x8mm, NBR  NJ312  80x100x10mm, MVQ		 BL360  BM920  BN450  BS110  BS700  BZ440, BZ450, BZ460  JC404  JC405  JC652  JM5046  JJ271
		JD5748 						
HBS281  (22-72001B) M12x1.50x198mm (x1) M12x1.50x162mm (x9)			JN918			 NJ134   NJ312  80x100x10mm, MVQ		
HBS284  (22-72003B) M12x1.50x198mm (x1) M12x1.50x163mm (x9)			JM5046			 NJ134   NA5242  40x52x7mm  NJ312  80x100x10mm, MVQ		
HBS282  (22-72002B) M11x1.50x230mm (x10)					HR5051 	 NB775  (x2) 40x52x7mm, FPM  NB774  35x45x7mm, FPM (50-319419-00)  NB843  [3] 128x145x28mm, FPM (50-319420-00)  LK5002  [3] 136x153x21mm, PTFE (50-319427-00)		
			HM5267  K20A6					
HBS281  (22-72001B) M12x1.50x198mm (x1) M12x1.50x162mm (x9)			JN918		PB355  (x8) PB356  (x8)	 NJ134   NA5242  40x52x7mm  NJ312  80x100x10mm, MVQ		
HBS284  (22-72003B) M12x1.50x198mm (x1) M12x1.50x163mm (x9)					PB355  (x8) PB356  (x8)	 NJ134   NA5242  40x52x7mm  NJ312  80x100x10mm, MVQ		
		JC652  JC404  JC405  (x2)  JE625	JN605 (50-028111-00)	JJ271	PA529  (x4) PA528  (x8)	 NJ313 29x45x8mm, ACM  NJ311  35x54x8mm, NBR  NJ312  80x100x10mm, MVQ		
		JC652  01/88 → JC404  JC405  (x2)  JF021 01/88 →	JN605 (50-028111-00) 01/88 →	JJ271 01/88 →	PA313  (x4) PA528  (x8)	 NJ313 29x45x8mm, ACM  NJ311  35x54x8mm, NBR  NJ312  80x100x10mm, MVQ		
HBS284  (22-72003B) M12x1.50x198mm (x1) M12x1.50x163mm (x9)		JD5750 			PB355  (x8) PB356  (x8)	 NJ134   NA5242  40x52x7mm  NJ312  80x100x10mm, MVQ		
HBS284  (22-72003B) M12x1.50x198mm (x1) M12x1.50x163mm (x9)		JD5750 	JM5046		PB355  (x8) PB356  (x8)	 NJ134   NA5242  40x52x7mm  NJ312  80x100x10mm, MVQ		



KW/PS

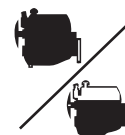

Model						Year Range	Power (KW/PS)	Engine Code	Notes
Accord 2.0L i LS						02/96 → 10/98	14	BZ700 (MLS), 1.55mm, 2 Holes (30-028565-00)	DS705
F20Z1	1997	4	85.00	Injection, SOHC	96/131				
Accord Aerodeck 2.0L i LS 16V						09/93 → 02/98	15	BV830 (MLS)	CG5350
Accord Coupe 2.0L						09/93 → 12/97			GV830
F20B3	1997	4	85.00		108/147				
Accord Coupe 2.0L i 16V						02/98 → 06/03	16	BV360 (MLS)	
F20B5/F20B7	1997	4	85.00	Injection, SOHC	108/147				
Accord Coupe 2.0L i 16V						01/92 → 09/93	17	BS700 (MLS) (30-028118-00)	CG5350
F20A7	1997	4	85.00	Injection	98/133				
Accord 2.2L i 16V						01/90 → 03/93	18	BS700 (MLS) (30-028118-00)	DS700 (21-28118-20/0)
Accord 2.2L i 16V Automatik						01/90 → 03/93			GS700
Accord Aerodeck 2.2L i 16V						01/91 → 12/93			
Accord Coupe 2.2L 16V Coupe						01/90 → 12/93			
F22A8	2156	4	85.00	Injection, SOHC	108/147				
F22A3	2156	4	85.00	Injection, SOHC	108-110/147-150				
F22A	2156	4	85.00	SOHC					
Accord 2.2L i VTEC						02/96 → 10/98	19	BV360 (MLS)	DV360 (21-28106-20/0)
F22Z2	2156	4	85.00	Injection, SOHC	110/150				
Accord 2.2L Type-R						02/99 → 12/02	20	AG5760 (MLS) H22A7	CG5761
H22A7	2157	4	87.00	Injection, DOHC	156/212			FG5761	
Accord Aerodeck 2.2L i 16V						01/91 → 12/93	21	BS700 (MLS) (30-028118-00)	DS700 (21-28118-20/0)
F22A7	2156	4	85.00	Injection, SOHC	110/150			GS700	
Accord Aerodeck 2.2L i ES						09/93 → 02/98	22	BV830 (MLS)	CG5350
Accord Coupe 2.2L i ES						09/93 → 02/98			GV830
F22B5	2156	4	85.00	Injection, SOHC	110/150				
Accord 1.6 V						02/98 →	23	AG5780 (MLS)	CG5780
F23A7	2254	4	86.00	SOHC	110/150			EG6210 (Rubber)	
Accord 2.3L						11/00 → 12/02	24	AG5780 (MLS)	CG5780
F23Z5	2254	4	86.00	Injection, DOHC	113/154			EG6210 (Rubber)	
Accord 2.3L i SR						03/93 → 01/96	25	BV030 (MLS) (30-028168-00)	DV030
H23A3	2259	4	87.00	Injection, DOHC	116/158			GV030	
Accord 2.4L						02/03 →	26		
K24A	2354	4	87.00	DOHC	140-147/190-200				

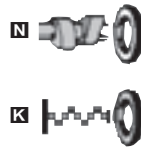
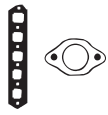

BS700



BV030



BV360

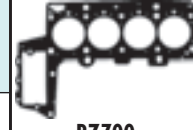

BZ700



JC883



JC884



JC885



JM5046

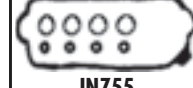

JN755



JJ417

HBS284 Ⓢ (22-72003B) M12x1.50x198mm (x1) M12x1.50x163mm (x9)	JD5750 Ⓢ	JM5046		PB355 Ⓢ PB356 Ⓢ	NJ134 Ⓢ NA5242 Ⓢ 40x52x7mm NJ312 Ⓢ 80x100x10mm, MVQ	
HBS284 Ⓢ (22-72003B) M12x1.50x198mm (x1) M12x1.50x163mm (x9)	JD5749 Ⓢ			PB355 Ⓢ (x8) PB356 Ⓢ (x8)	NJ134 Ⓢ NA5242 Ⓢ 40x52x7mm NJ312 Ⓢ 80x100x10mm, MVQ	
HBS281 Ⓢ (22-72001B) M12x1.50x198mm (x1) M12x1.50x162mm (x9)	JD5749 Ⓢ			PB355 Ⓢ (x8) PB356 Ⓢ (x8)	NJ134 Ⓢ NA5242 Ⓢ 40x52x7mm NJ312 Ⓢ 80x100x10mm, MVQ	
	JD5749 Ⓢ			PB355 Ⓢ (x8) PB356 Ⓢ (x8)	NJ134 Ⓢ NA5242 Ⓢ 40x52x7mm NJ312 Ⓢ 80x100x10mm, MVQ	
HBS284 Ⓢ (22-72003B) M12x1.50x198mm (x1) M12x1.50x163mm (x9)	JC883 Ⓢ JC885 Ⓢ	JN755 (50-028119-00)	JJ417	PA970 Ⓢ (x8) PA969 Ⓢ (x8)	NJ134 Ⓢ NA5242 Ⓢ 40x52x7mm NJ312 Ⓢ 80x100x10mm, MVQ	
HBS284 Ⓢ (22-72003B) M12x1.50x198mm (x1) M12x1.50x163mm (x9)	JD5749 Ⓢ Ⓢ KK5154			PB355 Ⓢ (x8) PB356 Ⓢ (x8)	NJ134 Ⓢ NA5242 Ⓢ 40x52x7mm NJ312 Ⓢ 80x100x10mm, MVQ	
HBS284 Ⓢ (22-72003B) M12x1.50x198mm (x1) M12x1.50x163mm (x9)		HM5266 Ⓢ H22A7		PB355 Ⓢ (x8) PB356 Ⓢ (x8)	NA5245 (x2) 29x43x8mm NA5242 Ⓢ 40x52x7mm NJ312 Ⓢ 80x100x10mm, MVQ	
HBS284 Ⓢ (22-72003B) M12x1.50x198mm (x1) M12x1.50x163mm (x9)	JC883 Ⓢ JC885 Ⓢ Ⓢ KK5154	JN755 (50-028119-00)	JJ417	PA970 Ⓢ (x8) PA969 Ⓢ (x8)	NJ134 Ⓢ NA5242 Ⓢ 40x52x7mm NJ312 Ⓢ 80x100x10mm, MVQ	
HBS284 Ⓢ (22-72003B) M12x1.50x198mm (x1) M12x1.50x163mm (x9)	JD5749 Ⓢ			PB355 Ⓢ (x8) PB356 Ⓢ (x8)	NJ134 Ⓢ NA5242 Ⓢ 40x52x7mm NJ312 Ⓢ 80x100x10mm, MVQ	
HBS281 Ⓢ (22-72001B) M12x1.50x198mm (x1) M12x1.50x162mm (x9)	JD5749 Ⓢ	JN918		PB355 Ⓢ PB356 Ⓢ	NJ134 Ⓢ NA5242 Ⓢ 40x52x7mm NJ312 Ⓢ 80x100x10mm, MVQ	
HBS281 Ⓢ (22-72001B) M12x1.50x198mm (x1) M12x1.50x162mm (x9)	JD5749 Ⓢ	JN918		PB355 Ⓢ (x8) PB356 Ⓢ (x8)	NJ134 Ⓢ NA5242 Ⓢ 40x52x7mm NJ312 Ⓢ 80x100x10mm, MVQ	
HBS284 Ⓢ (22-72003B) M12x1.50x198mm (x1) M12x1.50x163mm (x9)	JC883 Ⓢ JC884 Ⓢ Ⓢ JF024 Ⓢ (x2)			PA096 (x16) [117] PB354 Ⓢ (x8) PB353 Ⓢ (x8)	NJ134 Ⓢ NA5242 Ⓢ 40x52x7mm NJ312 Ⓢ 80x100x10mm, MVQ	
		HM5267 Ⓢ K24A3				



KW/PS

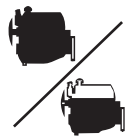

Model		Year Range		Displacement (cc)	Cylinders	Configuration	Power (kW/PS)	Code	Notes
Accord 3.0L Vtec Mk VII		10/98 → 12/02				27	AG9170 (MLS) (x2)	CG9170	EG5770
Accord Coupe 3.0L V6 24V		02/98 → 06/03							
J30A1	2997	6	86.00	Injection, SOHC, V6		147-149/ 200-203			
Acty TN Van 0.6L		08/79 → 06/86				28	BJ610 (Graphite)	DJ610 → Eng.2000000	GJ610 [12] → Eng.2000000 GJ611
EH	545	2	72.00	SOHC		23/31			
Ballade 1.5L CVCC		01/84 → 12/86				29	BM990 (Graphite) (30-026714-10)	DM993 01/85 → CRX AF DM995 (21-26714-22/0) 01/85 → AH / AN	EM992 AH / AK / AN GM991 AK / AH GM993 CRX AF GM992 01/84 →
EW1	1488	4	74.00	SOHC		63/74/ 86/101			
Ballade 1.5L CVCC 12V		01/84 →				30	BM990 (Graphite) (30-026714-10)	DM992	GM992
EW3/EW4	1488	4	74.00	SOHC		74/100			
Ballade 1.6L		01/92 →				31	BV350 (Graphite) (30-028143-00)	DV351 (21-28143-21/0)	
D16A7	1590	4	75.00	Injection, SOHC		96/131			
City 1.2L		10/81 → 12/86				32	BN240 (Graphite)	DN240	
City Convertible 1.2L		10/81 → 12/86							
City Van 1.2L		10/81 → 12/86							
ER	1231	4	66.00						
City 1.3L SES		05/03 → 09/05				33	AG9180 (MLS)	CG9180	
L13A1	1339	4	73.00			61/82			
City 1.5L		02/97 → 09/03				34			EV020
D15B7	1493	4	75.00	SOHC		74/100			
Civic 1.2L (AL)		01/84 → 10/87				35	BM990 (Graphite) (30-026714-10)		
ZA2	1187	4	74.00			40/54			
D12B1	1187	4	74.00	SOHC		40-41/ 54-56			
Civic 1.2L Mk IV		04/01 → 10/04				36	AG9180 (MLS)	CG9180	
Civic 1.2L Mk V		11/97 → 03/01							
L12A	1243	4	73.00			55/75			
L12A1	1243	4	73.00			57/77			
Civic 1.3L		10/83 → 10/87				37	BM990 (Graphite) (30-026714-10)	DM995 (21-26714-22/0)	EM992 GM990
EV2	1342	4	74.00	SOHC		59/80			
Civic 1.3L		10/87 → 12/89				38	BR540 (Graphite) (30-028137-00)	DR540 (21-28137-20/0)	GR540
D13B1	1343	4	75.00	SOHC		55/75			
Civic 1.3L 16 V		09/89 → 09/91				39	BV350 (Graphite) (30-028143-00)	DV351 (21-28143-21/0)	EV020
D13B2	1343	4	75.00	SOHC		55/75			
Civic 1.3L 16V		10/91 → 11/95				40	AG7890 (MLS)	CG7890	EV020
D13B2	1343	4	75.00	SOHC		55/75	01/92 →	01/92 →	
Civic 1.3L Mk IV		01/92 → 12/92				41	AG7890 (MLS)	CG7890	EV020
D13B2	1343	4	75.00	SOHC		55/75			
Civic 1.4L		02/01 → 09/05				42	AD5230 (MLS), 0.7mm	CD5230	
Civic 1.4L iS		02/01 → 09/05							
Civic 1.6V		01/01 →							
D14Z5	1396	4	75.00			66/89			
D14Z6	1396	4	75.00	SOHC		66/89			

							BJ610 BM990 BN240 BR540 BV350 JC521 JC532 JC534 JC674 JC863 JD052 JD075 JN404 JN434 JN562 JN574 JN580 JN744
		JN404			<input checked="" type="checkbox"/> NJ254 27x43x9mm, NBR <input checked="" type="checkbox"/> NK125E 30x42x8mm, NBR <input checked="" type="checkbox"/> NK102E 65x88x12mm, MVQ		
	JC521E JC534E	JN562 <i>(50-026763-00)</i> AK / AH JN580 CRX AF	JJ309	PA531E (x4) PA630 (x4) PA528E (x8)	<input checked="" type="checkbox"/> NJ313 29x45x8mm, ACM <input checked="" type="checkbox"/> NJ381E 31x46x8mm, NBR <input checked="" type="checkbox"/> NJ312E 80x100x10mm, MVQ		
	JC532E JF021 JF024	JN580	JJ309	PA531E (x4) PA630 (x4) PA528E (x8)	<input checked="" type="checkbox"/> NJ313 29x45x8mm, ACM <input checked="" type="checkbox"/> NJ381E 31x46x8mm, NBR <input checked="" type="checkbox"/> NJ312E 80x100x10mm, MVQ		
	JD075E JD052E JE625 JF024	JN744		PB355E (x8) PB356E (x8)	<input checked="" type="checkbox"/> NJ254 27x43x9mm, NBR <input checked="" type="checkbox"/> NJ381E 31x46x8mm, NBR <input checked="" type="checkbox"/> NJ312E 80x100x10mm, MVQ		
		JN434		PA288E (x4) PA373 (x4) [252] PA286E (x4)	<input checked="" type="checkbox"/> NJ254 27x43x9mm, NBR <input checked="" type="checkbox"/> NJ072E 35x50x8mm, NBR <input checked="" type="checkbox"/> NJ703E		
	JC521E JC534E (x2) JE625	JN574 01/84 → JN562 <i>(50-026763-00)</i> 01/85 →	JJ309	PA531E (x4) PA630 (x4) PA528E (x8)	<input checked="" type="checkbox"/> NJ313 29x45x8mm, ACM <input checked="" type="checkbox"/> NJ381E 31x46x8mm, NBR <input checked="" type="checkbox"/> NJ312E 80x100x10mm, MVQ		
	JC863E JC674E JF119	JN679 <i>(50-028138-00)</i>	JJ309	PA970E (x8) PA969E (x8)	<input checked="" type="checkbox"/> NJ313 29x45x8mm, ACM <input checked="" type="checkbox"/> NJ381E 31x46x8mm, NBR <input checked="" type="checkbox"/> NJ312E 80x100x10mm, MVQ		
		JM5134					



KW/PS

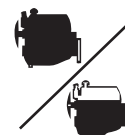

Civic 1.4L 16V						01/97 → 02/01	43					
Civic 1.4L i						11/95 → 02/01						
Civic 1.4L i S						11/95 → 02/01						
Civic Aerodeck 1.4L 16V						04/98 → 02/01						
D14A3	1396	4	75.00	Injection, SOHC		55/75						
D14A7	1396	4	75.00	SOHC		55/75						
D14A4	1396	4	75.00	Injection, SOHC		66/89						
D14A8	1396	4	75.00	SOHC		66/89						
D14Z2	1396	4	75.00	Injection, SOHC		66/90						
D14Z1	1396	4	75.00	Injection, SOHC		66/90						
Civic 1.4L i						09/94 → 01/97	44			EV020		
D14A5	1396	4	75.00	Injection		55/75						
D14A2	1396	4	75.00	Injection, SOHC		66/89						
Civic 1.4L i 16V Mk II Shuttle						01/88 → 12/92	45	BR540 (Graphite) (30-028137-00)	DR540 (21-28137-20/0)			
Civic 1.4L L						10/87 → 12/89						
Civic 1.4L Mk V						11/95 → 10/98						
D14A1	1396	4	75.00	SOHC		61-66/ 83-90						
D14A4	1396	4	75.00	Injection, SOHC		66/89						
Civic 1.4L I Mk VI						02/01 → 09/05	46					
	1396	4				55/75						
Civic Aerodeck 1.4L 16V						04/98 → 02/01	47					
D14A7	1396	4	75.00	SOHC		55/75						
Civic 1.5L Mk V						11/95 → 12/96	48			EV020		
Civic Coupe 1.5L Mk IV						08/93 → 12/95						
Civic 1.5L Mk IV						01/92 → 09/95						
D15Z3	1493	4	75.00	Injection, DOHC		66/89						
D15B2	1493	4	75.00			66/69/ 90/94						
D15Z1	1493	4	75.00	Injection, SOHC		69/93						
D15B7	1493	4	75.00	SOHC		74/100						
Civic 1.5L						10/83 → 10/87	49	BM990 (Graphite) (30-026714-10)	DM995 (21-26714-22/0)			
Civic 1.5L 4WD						01/85 → 10/87						
Civic 1.5L GL						10/83 → 10/87						
EW2	1488	4	74.00	SOHC		74/100						
Civic 1.5L 16V						01/97 → 02/01	50					
Civic Aerodeck 1.5L 16V						04/98 → 02/01						
D15Z8	1493	4	75.00	SOHC		84/114						
Civic 1.5L CRX						01/84 → 12/86	51	BM990 (Graphite) (30-026714-10) 01/84 →	DM993 ■ 01/85 → CRX AF DM995 (21-26714-22/0) 01/85 → AH / AN	EM992 AH / AK / AN GM991 AK / AH GM993 CRX AF GM992 01/84 →		
Civic 1.5L i Shuttle						01/83 → 12/87						
Civic 1.5L II						10/83 → 10/87						
EW1	1488	4	74.00	SOHC		63/74/ 86/101						
Civic 1.5L GT						01/85 → 10/87	52	BM990 (Graphite) (30-026714-10)	DM992			
Civic 1.5L GTI						03/86 → 10/87						
EW3/EW4	1488	4	74.00	SOHC		74/100						

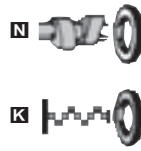
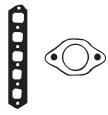

BM990



BR540



JC521



JC534



JD170



JD600



JN562



JN580



JJ309







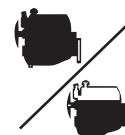



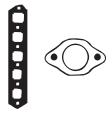

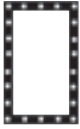

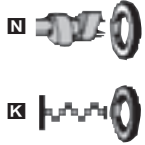





	JD5748E	JM5135		PA970E (x8) PA969E (x8)	NJ313 29x45x8mm, ACM NJ381E 31x46x8mm, NBR NJ312R 80x100x10mm, MVQ	
	JD5748E					
		JM5135				
HBS300® (22-33034B) M12x1.75x166mm (x10)	JD170E 31-026556-10 JD600E 31-028454-00	JM5120 50-029555-00	HR397 [57] 34-000410-00	HR816E 24-30653-85/0	NA5124 32x47x10mm, PTFE (50-319433-00) NA5106E 35x48x10mm, PTFE (50-319430-00) LK5003E [3] 85x131x15.7mm, PTFE (50-319434-00)	HL5034 [245]E
	JD5748E	JM5135				
	JD5748E					
	JC521E 01/84→ JC534E 01/84→	JN562 (50-026763-00) AK / AH JN580 CRX AF	JJ309	PA531E (x4) PA630 (x4) PA528E (x8)	NJ313 29x45x8mm, ACM NJ381E 31x46x8mm, NBR NJ312R 80x100x10mm, MVQ	



KW/PS

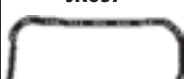

Civic 1.5L i						11/95 → 02/01	53		DY863	
D15Z6	1493	4	75.00	Injection, SOHC		84/114		01/96 → 12/00		
Civic 1.5L i 16V						10/87 → 11/95	54	BR540 (Graphite)	DR541	EV020
D15B2	1493	4	75.00			66/69/ 90/94	(30-028137-00)			
Civic 1.5L i 16V						10/87 → 11/91	55	BR540 (Graphite)	DR541	EV020 GR540
D15B2	1493	4	75.00			66/69/ 90/94	(30-028137-00)			
Civic 1.5L i 16V						10/91 → 11/95	56	BV020 (MLS)	DV020	EV020 GV020
D15B2	1493	4	75.00			66/69/ 90/94	(30-028146-00)		(21-28146-20/0)	
D15Z1	1493	4	75.00	Injection, SOHC		69/93				
Civic 1.5L i Vtec-E						09/94 → 01/97	57	BV020 (MLS)	DY863	EV020
D15Z3	1493	4	75.00	Injection, DOHC		66/89	(30-028146-00)	01/95 → 12/96	D15Z3	
Civic Coupe 1.5L i LSi						01/94 → 11/95	58	BV350 (Graphite)	DV350	EV020
D15B7	1493	4	75.00	SOHC		74/100	(30-028143-00)			
Civic i 16V						10/91 → 11/95	59	BV020 (MLS)	DV020	EV020 GR540 GV020
D15B2	1493	4	75.00			66/69/ 90/94	(30-028146-00)		(21-28146-20/0)	
D15Z1	1493	4	75.00	Injection, SOHC		69/93				
Civic 1.6L Mk V						10/95 → 09/00	60	BV020 (MLS)	DV020	EV020
Civic 1.6L 4x4 Mk IV						01/92 → 10/95		(30-028146-00)	(21-28146-20/0)	
Civic 1.6L Mk IV						10/91 → 10/93				
D16Z7	1590	4	75.00	SOHC		88-92/ 120- 125				
D16Z6	1590	4	75.00	Injection, DOHC		92/125				
D16Y2	1590	4	75.00	MPI, DOHC		93/126				
Civic 1.6L VTi						10/91 → 11/95	61	BV040 (MLS)	DV041	EV050
Civic 1.6L VTi 16V						10/91 → 11/95				
Civic Coupe 1.6L i Vtec						01/94 → 12/00				
B16A2	1595	4	81.00	Injection, SOHC		118/160				
Civic 1.6L						02/01 → 09/05	62	AD5230 (MLS, 0.7mm)	CD5230	FD5230
Civic 1.6L i						02/01 → 09/05			CD5231	
Civic Coupe 1.6L i						02/01 → 12/05				
D16V1	1590	4	75.00			81/110				
Civic 1.6L 16V						10/84 → 12/87	63	BR540 (Graphite)	DP630	ES880
Civic 1.6L 16V 3.6i						10/84 → 12/87		(30-028137-00)	01/86 → 12/87	01/86 →
Civic 1.6L 16V 5.6i						10/84 → 12/87		BP630 (Graphite)		
Civic 1.6L 16V RTi 4WD						10/84 → 12/87		01/86 → 12/87		
Civic 1.6L 16V Shuttle						10/84 → 12/87		BS880 (Graphite)		
Civic 1.6L 16V Shuttle 4WD						10/84 → 12/87		(30-028150-00)		
ZC	1590	4	75.00	SOHC		77/105		01/88 →		
Civic 1.6L 16V						01/97 → 02/01	64			
Civic Aerodeck 1.6L 16V						04/98 → 02/01				
D16B2	1590	4	75.00	SOHC		85/116				
Civic 1.6L 16V CRX						01/92 →	65	BV350 (Graphite)	DV351	(21-28143-21/0)
D16A7	1590	4	75.00	Injection, SOHC		96/131	(30-028143-00)			

								
		JD5748E						 BP630
								 BR540
								 BS880
		JC863E JC674E ☉JF119	JN679 (50-028138-00)	JJ309	PA970E (x8) PA969E (x8)	NJ313 29x45x8mm, ACM NJ381E 31x46x8mm, NBR NJ312E 80x100x10mm, MVQ		 BV020
		JD074E JD075E JC674E JD052E ☉JF024 (x2)	JN857 (50-028147-00)		PB355E (x8) PB356E (x8)	NJ312E 80x100x10mm, MVQ NJ313E 29x45x8mm, ACM		 BV350
		JD5748E						 JC674
		JD051E JD052E ☉JE625	JN744		PB355E (x8) PB356E (x8)	NJ312E 80x100x10mm, MVQ NJ313E 29x45x8mm, ACM		 JC863
		JD074E JD075E JC674E JD052E ☉JF024 (x2)	JN679 (50-028138-00) JN857 (50-028147-00)		PB355E (x8) PB356E (x8)	NJ312E 80x100x10mm, MVQ NJ313E 29x45x8mm, ACM		 JD051
		JD074E JD075E JD052E ☉JF024	JN857 (50-028147-00)		PA969 PA970	NJ313 29x45x8mm, ACM NJ313E 29x45x8mm, ACM NJ312E 80x100x10mm, MVQ		 JD052
			HM5228E					 JD074
								 JD075
								 JN632
								 JN744
								 JN857
		JC674E 01/86→ ☉JE625 01/86→	JN632 01/86→12/87	JJ309 01/86→12/89	PA531E (x4) PA528E (x8)	NJ254 27x43x9mm, NBR NJ381E 31x46x8mm, NBR NK005E 31x46x8mm, NBR NJ312E 80x100x10mm, MVQ		 JJ309
		JD5748E						
		JD075E JD052E ☉JE625 ☉JF024 (x2)	JN744		PB355E (x8) PB356E (x8)	NJ254 27x43x9mm, NBR NJ313E 29x45x8mm, ACM NJ312E 80x100x10mm, MVQ		



KW/PS

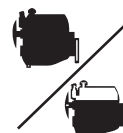

Civic 1.6L 16V Vtec						10/91→11/95	66	BV020 (MLS)	DV020	EV020
D16Z7	1590	4	75.00	SOHC	88-92/ 120- 125	(30-028146-00)		(21-28146-20/0)	GV020	
D16Z6	1590	4	75.00	Injection, DOHC	92/125					
Civic 1.6L i						09/94→01/97	67	AG7900 (MLS)	CG7900	EV020
D16Y3	1590	4	75.00	Injection, DOHC	83/113			01/95→		
Civic 1.6L i						11/95→02/01	68		DY863	
D16Y5	1590	4	75.00	Injection, SOHC	84/114			01/96→12/98		
Civic 1.6L i 16V						10/87→09/91	69	BV350 (Graphite)	DV351	
Civic 1.6L i 16V 4WD						01/88→02/95		(30-028143-00)	(21-28143-21/0)	
Civic 1.6L i 16V 4x4						10/89→09/91				
D16A6	1590	4	75.00	Injection, SOHC	79-81/ 107- 110					
Civic 1.6L i 16V						10/87→09/91	70	BV350 (Graphite)	DV351	FD5230
D16Z2	1590	4	75.00	Injection, SOHC	81-82/ 110- 112	(30-028143-00)		(21-28143-21/0)		
Civic 1.6L i 16V						01/89→12/91	71	BS880 (Graphite)	DS881	GS881
D16A9	1590	4	75.00	Injection, DOHC	96/131	(30-028150-00)		(21-28150-20/0)		
Civic 1.6L i 16V						09/87→09/91	72	BV350 (Graphite)	DV351	
D16A7	1590	4	75.00	Injection, SOHC	96/131	(30-028143-00)		(21-28143-21/0)		
D16A9	1590	4	75.00	Injection, DOHC	96/131					
Civic 1.6L i 16V Vtec						10/89→09/91	73	BV040 (MLS)	DV041	EV050
B16A1	1595	4	81.00	Injection, DOHC	110/150		01/91→	01/91→	01/91→	
Civic 1.6L i Vtec						11/95→02/01	74		DV022	
D16Y8	1590	4	75.00	Injection, SOHC	84-92/ 114- 125			01/96→12/98		
D16Y6	1590	4	75.00	Injection, SOHC	92/125			D16Y6		
Civic 1.6L i Vtec						09/94→01/97	75	BV020 (MLS)	DV020	EV020
D16Y2	1590	4	75.00	MPi, DOHC	93/126	(30-028146-00)		(21-28146-20/0)	DY863	
								01/96→		
								D16Y2		
Civic 1.6L VTi						11/95→02/01	76	BV040 (MLS)	DV041	EV050
B16A2	1595	4	81.00	Injection, SOHC	118/160		→12/00	→12/00	→12/00	
Civic Coupe 1.6L i						01/94→11/95	77		DV022	
D16Y7	1590	4	75.00	Injection, SOHC	77/105					
Civic Coupe 1.6L i						03/96→03/00	78		DV022	
Civic Coupe 1.6L i Vtec						03/96→03/00			DY863	
D16Y7	1590	4	75.00	Injection, SOHC	77/105			→12/98		
D16Y8	1590	4	75.00	Injection, SOHC	84-92/ 114- 125			D16Y2/6/8		
Civic Coupe 1.6L i Vtec						01/94→03/96	79	BV020 (MLS)	DV022	EV020
D16Y6/D16Z9	1590	4	75.00	Injection, SOHC	92/125	(30-028146-00)				
Civic 1.7L						02/01→09/05	80		CG5790	
Civic Coupe 1.7L i						05/01→12/05				
D17A6	1668	4	75.00	Injection, SOHC	87/118					
D17A8	1668	4	75.00		88/120					
Civic Coupe 1.7L i VTEC						05/01→12/05	81	AD5230 (MLS), 0.7mm	CG5792	
D17A5/D17A9	1668	4	75.00		92/125		06/01→	06/01→	D17A9	

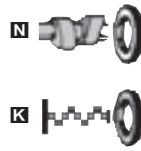
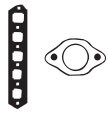

BS880



BV020



BV350



JC674



JD052



JD074



JD075



JN744

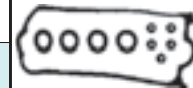

JN857



JN925



JJ309



KW/PS



Civic CTDi Diesel		01/02 → 09/05		82	AG9840 (MLS), 1,45mm AG9850 (MLS), 1,50mm AG9860 (MLS), 1,55mm		
4EE-2	1686	4	79.00	Direct Injection, SOHC	74/100		
Civic 1.8L 16V		01/97 → 02/01		83	BV040 (MLS) →12/00	DV041 →12/00	EV050 →12/00
Civic Aerodeck 1.8L 16V		04/98 → 02/01					
B18C4	1797	4	81.00	Injection, DOHC	124/168	B18C1	B18C1
Civic 2.0L i Sport		01/04 → 09/05		84	AG8130 (MLS)	CG8130	FG8130
Civic 2.0L Mk IV		10/03 → 09/05					
Civic 2.0L Mk VII		02/06 →					
Civic 2.0L Type-R		09/01 → 09/05					
K20A3	1998	4	86.00		118/160		
K20A2	1998	4	86.00	Injection, DOHC	147/200		
Civic 2.0L i TD Diesel		01/97 → 02/01		85	BZ440 (MLS), 1.05mm, 1 Hole (30-029569-00)	DZ440▲ (21-29569-20/0)	EZ440 [12] (22-29569-00/0)
Civic Aerodeck 2.0L i D Diesel		04/98 → 02/01					
20T2N	1994	4	84.45	Direct Injection, SOHC	77/105	BZ450 (MLS), 1.20mm, 2 Holes (30-029570-00)	
20T2R	1994	4	84.50		63/86	BZ460 (MLS), 1.35mm, 3 Holes (30-029571-00)	
Concerto 1.4L		08/89 → 10/92		86			
D14A1	1396	4	75.00	SOHC	61-66/ 83-90		
D14A8	1396	4	75.00	SOHC	66/89		
Concerto 1.5L i 16V		08/89 → 03/95		87	BR540 (Graphite) (30-028137-00)	DR541	EV020 GR540
D15B2	1493	4	75.00		66/69/ 90/94		
Concerto 1.6L 16V		08/89 → 03/95		88	BV350 (Graphite) (30-028143-00)	DV351 (21-28143-21/0)	FD5230
Concerto 1.6L i 16V		08/89 → 03/95					
D16V1	1590	4	75.00		81/110		
D16Z2	1590	4	75.00	Injection, SOHC	81-82/ 110- 112		
Concerto 1.6L EXi		01/92 →		89	BV350 (Graphite) (30-028143-00)	DV351 (21-28143-21/0)	
Concerto 1.6L i 16V		01/92 →					
D16A7	1590	4	75.00	Injection, SOHC	96/131		
Concerto 1.6L i 16V		08/89 → 03/95		90	BS880 (Graphite) (30-028150-00)	DS881 (21-28150-20/0)	
D16A8	1590	4	75.00	Injection, DOHC	90/122		
Concerto 1.6L i 16V		01/89 → 12/94		91	BS880 (Graphite) (30-028150-00)	DS881 (21-28150-20/0)	GS881
D16A9	1590	4	75.00	Injection, DOHC	96/131		
Concerto 1.8L TD Diesel		08/94 → 10/96		92	BX830 (Fibre), 1.36mm, 1 Notch (30-028484-00) ⊖0.56 → 0.67mm BX840 (Fibre), 1.40mm, 2 Notches (30-028485-00) ⊖0.68 → 0.71mm BX850 (Fibre), 1.44mm, 3 Notches (30-028486-00) ⊖0.72 → 0.75mm BX860 (Fibre), 1.48mm, 4 Notches (30-028487-00) ⊖0.76 → 0.79mm BX870 (Fibre), 1.52mm, 5 Notches (30-028488-00) ⊖0.80 → 0.83mm	DJ720▲ (21-25202-22/0)	EL890 (22-25198-01/0) GJ720▲ (20-25202-02/0)
XUD7T	1769	4	80.00	Indirect Injection, SOHC	58-65/ 79-88		
CR-V 2.0L		07/02 → 09/06		93	AG5810 (MLS) K20A(I-VTEC)	CG5811	FG8131
K20A4	1998	4	86.00	Injection, DOHC	110/150		

HBS036 ® (22-29001B) M12x1.5x102mm (x10)							BR540 BS880 BV350 BX830, BX840, BX850, BX860, BX870 BZ440, BZ450, BZ460 JC674 JC863 JD052 JD075 JN544 JN744 JN925 JJ283 JJ309
HBS282 ® (22-72002B) M11x1.50x230mm (x10)		HM5228			HR5051	NB775 (x2) 40x52x7mm, FPM NB774 35x45x7mm, FPM (50-319419-00) NB843 [3] 128x145x28mm, FPM (50-319420-00) LK5002 [3] 136x153x21mm, PTFE (50-319427-00)	BX830, BX840, BX850, BX860, BX870 BZ440, BZ450, BZ460 JC674 JC863 JD052 JD075 JN544 JN744 JN925 JJ283 JJ309
		JM5135					JC674 JC674
	JC863 JC674 	JN679 (50-028138-00)	JJ309	PA970 (x8) PA969 (x8)	NJ313 29x45x8mm, ACM NJ381 31x46x8mm, NBR NJ312 80x100x10mm, MVQ		JN544 JN744 JN925 JJ283 JJ309
	JD075 JD052 	JN744		PB355 (x8) PB356 (x8)	NJ254 27x43x9mm, NBR NJ381 31x46x8mm, NBR NJ312 80x100x10mm, MVQ		JN544 JN744 JN925 JJ283 JJ309
	JC674	JN925	JJ309	PB156 (x16)	NJ313 29x45x8mm, ACM NJ381 31x46x8mm, NBR NJ312 80x100x10mm, MVQ		JN544 JN744 JN925 JJ283 JJ309
HBS084 ® (22-15005B) M12x1.50x123mm (x10)		JN544 (50-025202-00)	JJ283 [6] (31-025198-10)	HR569 24-30667-00/0	NF841 35x50x8mm, FPM (50-319310-00) NA5191 42x62x7mm, PTFE (50-319500-00) NA5192 90x110x7mm, PTFE (50-319501-00)	HL5010 [245]	JN544 JN744 JN925 JJ283 JJ309
		HM5267 K20A(I-VTEC)					JN544 JN744 JN925 JJ283 JJ309



KW/PS



CR-V 2.0L 16V 01/99 → 02/02 94						BV050 (MLS)	DV050	EV050			
CR-V 2.0L Mk I 04/99 → 02/02											
B20Z1	1973	4	84.00		108/147						
CR-V 2.0L 16V 10/95 → 01/99 95						BV050 (MLS) 01/97 →	DV050 01/97 →	EV050 01/97 →			
B20B	1973	4	84.00		94/128						
CRX Coupe 1.3L 10/83 → 10/87 96						BM990 (Graphite) (30-026714-10)					
EV2	1342	4	74.00	SOHC	59/80						
CRX 1.4L GL Mk II 01/90 → 12/91 97											
D14A1	1396	4	75.00	SOHC	61-66/ 83-90						
CRX 1.5L i 16V 01/88 → 11/91 98						BR540 (Graphite) (30-028137-00)	DR540 (21-28137-20/0) EF DR541 CRX / EF	GR540 EF GR541 CRX EF			
D15B2	1493	4	75.00		66/69/ 90/94						
CRX 1.5L i 16V 10/91 → 11/95 99						BV020 (MLS) (30-028146-00)	DV020 (21-28146-20/0)	GV020			
D15Z1	1493	4	75.00	VTEC, Injection, SOHC	69/93						
CRX 1.5L Mk III 01/94 → 04/98 100								EV020			
D15B7	1493	4	75.00	SOHC	74/100						
CRX Coupe 1.5L i 10/83 → 11/86 101						BM990 (Graphite) (30-026714-10)	DM992	GM992			
EW3	1488	4	74.00	SOHC	74/100						
CRX 1.6L ESi 03/92 → 12/98 102						BV020 (MLS) (30-028146-00)	DV020 (21-28146-20/0)	EV020 GV020			
D16Y8	1590	4	75.00	Injection, SOHC	84-92/ 114- 125						
D16Z6	1590	4	75.00	Injection, DOHC	92/125						
CRX 1.6L i 16V 10/87 → 02/92 103						BS880 (Graphite) (30-028150-00)	DS881 (21-28150-20/0)				
D16Z5	1590	4	75.00	Injection, DOHC	91/124						
CRX 1.6L i VTi 03/92 → 12/98 104						BV040 (MLS) B16A2	DV041 B16A2	EV050 B16A2			
B16A2	1595	4	81.00	Injection, SOHC	118/160						
CRX Coupe 1.6L i 16V 10/87 → 05/88 105						BV350 (Graphite) (30-028143-00)	DV351 (21-28143-21/0)				
D16A6	1590	4	75.00	Injection, SOHC	79-81/ 107- 110						
D16A	1590	4	75.00	SOHC	79-91/ 107- 124						
CRX Coupe 1.6L i 16V 03/86 → 10/87 106						BR540 (Graphite) (30-028137-00) BP630 (Graphite) 01/86 → 12/87 BS880 (Graphite) (30-028150-00) 1988 →	DP630	ES880			
ZC1	1590	4	75.00	Injection, DOHC	92/125						
CRX Coupe 1.6L i 16V 10/87 → 12/89 107									BS880 (Graphite) (30-028150-00)	DS881 (21-28150-20/0)	GS881
D16A9	1590	4	75.00	Injection, DOHC	96/131						
CRX Coupe 1.6L i 16V Vtec 10/89 → 02/92 108						BV040 (MLS) 01/92 →		EV050			
B16A1	1595	4	81.00	Injection, DOHC	110/150						
DOMANI 1.6L 11/88 → 12/97 109								FD5230			
D16Z2	1590	4	75.00	Injection, SOHC	81-82/ 110- 112						
Edix 2.0L 08/04 → 09/06 110								FG8131			
Edix 2.0L 4x4 08/04 → 09/06											
K20A9	1998	4	86.00		110/150						

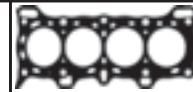
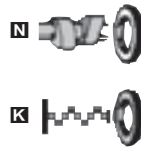
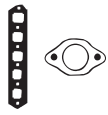

BM990



BP630



BR540



BS880



BV020



BV350



JC532



JC674



JC863



JD074



JD075



JN580



JN632

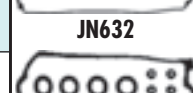

JN857

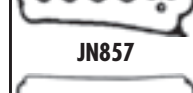

JN925



JJ309



HM5246

HM5246

JM5135

JC863
EF
JC674
JF119

JN679
(50-028138-00)

JJ309

PA970 (x8)
PA969 (x8)

NJ313 29x45x8mm, ACM
NJ381 31x46x8mm, NBR
NJ312 80x100x10mm, MVQ

JD074
JD075
JD052
JF024

JN857
(50-028147-00)

PB355 (x8)
PB356 (x8)

NJ312 80x100x10mm, MVQ
NJ313 29x45x8mm, ACM

JC532
JF021
JF024

JN580

JJ309

PA531 (x4)
PA630 (x4)
PA528 (x8)

NJ313 29x45x8mm, ACM
NJ381 31x46x8mm, NBR
NJ312 80x100x10mm, MVQ

JD074
JD075
JD052
JF024 (x2)

JN857
(50-028147-00)

PA970 (x8)
PA969 (x8)

NJ313 29x45x8mm, ACM
NJ313 29x45x8mm, ACM
NJ312 80x100x10mm, MVQ

HM5228

JC674
JE625
KK5154

JN632

JJ309

PA531 (x8)
PA528 (x8)

NJ254 27x43x9mm, NBR
NJ381 31x46x8mm, NBR
NJ312 80x100x10mm, MVQ

JC674

JN925

JJ309

PB156 (x8)

NJ254 27x43x9mm, NBR
NJ381 31x46x8mm, NBR
NJ312 80x100x10mm, MVQ







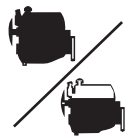



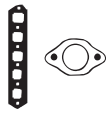

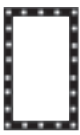

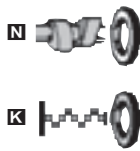

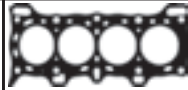









HM5228



KW/PS



Fit 1.3L 05/03 → 111					AG9180 (MLS)	CG9180	
L13A1	1339	4	73.00	61/82			
Fit Aria 1.3L 09/01 → 10/04 112					AG9180 (MLS)	CG9180	
Fit Aria 1.3L 4WD 09/01 → 10/04							
L13A1	1339	4	73.00	61/82			
FR-V 2.0L 02/05 → 113							FG8131
K20A9	1998	4	86.00	110/150			
HR-V 1.6L 16V 03/99 → 114							GY861
HR-V 1.6L 16V 4WD 03/99 →							
D16W1	1590	4	75.00	Injection, SOHC 77/105			
Insight 1.0L Vtec 04/00 → 10/04 115							FG7960
ECA1	995	3	72.00	56/76			
Insight Coupe 1.0L 08/00 → 116					AG7960 (MLS)	CG7960	FG7960
ECA1	995	3	72.00	56/76	ECA1	ECA1	
Integra 1.5L 01/83 → 12/87 117					BM990 (Graphite) (30-026714-10) 01/84 →	DM993 ■ 01/85 → CRX AF DM995 (21-26714-22/0) 01/85 → AH / AN	EM992 AH / AK / AN GM991 AK / AH GM993 CRX AF GM992 01/84 →
EW1	1488	4	74.00	SOHC 63/74/ 86/101			
Integra 1.6L 16V 10/84 → 12/87 118					BR540 (Graphite) (30-028137-00)	DP630 01/86 → 12/87	ES880 01/86 →
Integra 1.6L 16V SOHC 10/84 → 12/87					BP630 (Graphite) 01/86 → 12/87		
ZC	1590	4	75.00	SOHC 77/105			
Integra 1.8L 16V 01/90 → 12/90 119					BS890 (MLS)		ES890
B18A	1834	4	81.00	DOHC			
Integra Coupe 1.8L Type-R 11/97 → 10/01 120					BV040 (MLS)		
B18C6	1797	4	81.00	Injection, DOHC 140/190			
Integra 2.0L 02/02 → 121					AG8130 (MLS)		FG8130
K20A3	1998	4	86.00	118/160			
K20A2	1998	4	86.00	Injection, DOHC 147/200			
Jazz 1.2L 03/02 → 122					AG9180 (MLS)	CG9180	
L12A1	1243	4	73.00	57/77			
Jazz 1.4L 03/02 → 123					AG9180 (MLS)	CG9180	
L13A1	1339	4	73.00	61/82			
Legend 2.5L i 01/86 → 06/88 124					BP640 (Graphite) (x2)		
C25A1	2494	6	84.00	Injection, SOHC, V6 110/150			
C25A2	2494	6	84.00	Injection, SOHC, V6 124- 127/ 169- 173			
Legend 2.7L i 24V 01/88 → 12/90 125					BR650 (Graphite) (x2)	DR650 (21-28158-20/0)	
Legend Coupe 2.7L i 24V 10/87 → 12/90							
C27A1	2675	6	87.00	Injection, SOHC, V6 124/168			
Legend 3.2L i 24V 01/91 → 02/96 126					BV090 (Graphite) ■	DV090	
Legend Coupe 3.2L i 24V 01/91 → 02/96					BV100 (Graphite) ■		
C32A2	3206	6	90.00	SOHC 151/205			

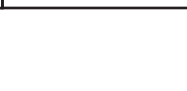





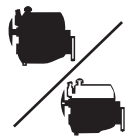



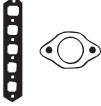

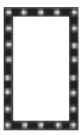

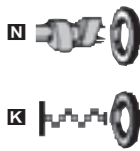



























































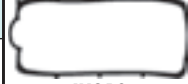







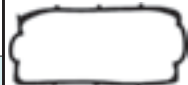







									
								 BM990	 JN633
								 BP630	 JN757
								 BP640	 JJ309
								 BR540	 JJ364
			JM5300					 BR650	
			JM5300					 BS890	
	JC521 ■ 01/84 → JC534 ■ 01/84 →	JN562 (50-026763-00) AK / AH JN580 CRX AF	JJ309	PA531 ■ (x4) PA630 (x4) PA528 ■ (x8)	NJ313 29x45x8mm, ACM NJ381 ■ 31x46x8mm, NBR NJ312 ■ 80x100x10mm, MVQ			 BV090	
	JD052 ■ JC674 ■ 01/86 → JE625 01/86 →	JN632 01/86 →	JJ309 01/86 →	PA531 ■ (x4) PA528 ■ (x8)	NJ254 27x43x9mm, NBR NJ381 ■ 31x46x8mm, NBR NK005 ■ 31x46x8mm, NBR NJ312 ■ 80x100x10mm, MVQ			 BV100	
	JE625	JN757		PB156 (x16)	NJ254 27x43x9mm, NBR NJ311 ■ 35x54x8mm, NBR NJ312 ■ 80x100x10mm, MVQ			 JC521	
		HM5228 ■						 JC534	
								 JC674	
	JD5838 ■ JD5839 ■ JD5840 ■	HM5275 ■						 JC687	
HBS281 ⊙ (22-72001B) M12x1.50x198mm (x1) M12x1.50x162mm (x9)	JD5838 ■ JD5839 ■ JD5840 ■	HM5275 ■						 JC791	
	JC687 ■ (x2) JE625	JN633 (x2)	JJ364	PA528 ■ (x12)	NJ933 (x2) 35x50x8mm, FPM NK023 ■ 41x56x8mm, ACM NJ675 ■ 80x98x10mm, NBR			 JD052	
	JC791 ■ (x2) JC687 ■ (x2) JE625 JF021	JN633 (x2)	JJ364	PA528 ■ (x12)	NJ933 (x2) 35x50x8mm, FPM NK023 ■ 41x56x8mm, ACM NJ675 ■ 80x98x10mm, NBR			 JN562	
		HM5248 ■ (x2)		PB355 ■ (x12) PB356 ■ (x12)	NJ933 (x2) 35x50x8mm, FPM NK023 ■ 41x56x8mm, ACM NJ675 ■ 80x98x10mm, NBR			 JN580	
								 JN632	



KW/PS



Logo 1.3L					03/99 → 03/02	127		DV021	GV021
D13B7	1343	4	75.00	Injection, SOHC		48/65			
NSX Convertible 3.0L 24V Vtec					03/95 → 09/05	128	AG7860 Soft Material Gasket	CG7860	FG7860
NSX Coupe 3.0L 24V Vtec					06/90 → 09/05			→12/97	
C30A3	2977	6	90.00	Injection, DOHC, V6		201/273			
NSX Convertible 3.0L 24V Vtec					03/95 → 09/05	129	AG7860 Soft Material Gasket	CG7860	
Automatic								→12/97	
NSX Coupe 3.0L 24V Vtec Automatic					06/90 → 09/05				
C30A4	2977	6	90.00	MPi, DOHC, V6		201/273			
NSX Convertible 3.2L 24V Vtec					01/97 → 09/05	130	AG7870 (MLS)	CG7870	
NSX Coupe 3.2L 24V Vtec					01/97 → 09/05				
C32B2	3179	6	93.00	V6		206/280			
Prelude 1.6L					01/80 → 12/85	131	BE120 (Graphite) 01/80 → 09/81 BK100 (Fibre) 10/81 →	DK100 (21-26212-22/0) 10/81 →	
EP	1602	4	77.00			66/89			
Prelude 1.8L 12v					01/88 → 12/89	132	BS110 (Graphite)		
B18	1834	4	81.00	DOHC					
Prelude 1.8L 12v CVCC					→12/86	133	BL360 (Graphite) 11/82 → 12/84 BM920 (Graphite) (30-026713-10) 01/84 → 12/86	DL361 10/83 → 12/89 DM920 01/84 → 12/86	GM920 01/84 → 12/86
ES	1829	4	80.00	SOHC		81/110			
Prelude 1.8L 16V					01/90 → 12/90	134	BS890 (MLS)		ES890
B18A	1834	4	81.00	DOHC					
Prelude Coupe 1.8L 12v					01/84 → 12/85	135	BM920 (Graphite) (30-026713-10)	DM921	
ET	1829	4	80.00			95/130			
Prelude 2.0L 12V					01/87 → 12/89	136	BN450 (Graphite) (30-028115-00)	DN451	GN451
A20A4	1955	4	82.70	Injection, SOHC		90/122			
Prelude Coupe 2.0L					08/87 → 01/92	137	BS110 (Graphite)	DS111	
Prelude Coupe 2.0L EX					04/87 → 01/92				
B20A3	1958	4	81.00	Carburettor, SOHC		80/109			
B20A4	1958	4	81.00	Carburettor		84/114			
Prelude Coupe 2.0L 16V					10/96 → 10/00	138	BS700 (MLS) (30-028118-00)	DS700 (21-28118-20/0)	
Prelude Coupe 2.0L i 16V					02/92 → 09/96				
F20A4	1997	4	85.00	Injection, SOHC		98/133			
Prelude Coupe 2.0L i EX 16V					10/87 → 01/92	139	BS110 (Graphite)	DS111	GS111
B20A9	1958	4	81.00	Injection, DOHC		103/140			
B20A7	1958	4	81.00	Injection, DOHC		110/150			
Prelude Coupe 2.0L i EX 16V					04/87 → 01/92	140	BP740 (Graphite) →12/87 BS110 (Graphite) 01/88 →	DP740 →12/87 DS111 01/88 →	GS111 01/88 → 12/92
B20A5	1958	4	81.00	Injection, DOHC		101/137			
Prelude Coupe 2.2L 16V					10/96 → 10/00	141	AG5760 (MLS) 01/97 →	CG5760 01/97 →	FG5760
H22A5	2157	4	87.00	Injection, DOHC		136/185			

									
			HM5249 						
			HM5247 						
			HM5247 						
									
	 JE625 10/81 →	JN318 01/80 → 10/81 JN434 10/81 →	JH171	PA313  (x4) PA373 (x4) [252] PA424  (x4)	NJ254 27x43x9mm, NBR NJ072  35x50x8mm, NBR NJ073  74x98x12mm, MVQ → 09/81 NJ309  76x98x12mm, NBR 10/81 →				
	 JF024	JN769	JJ390	PA529  (x4) PA528  (x8)	NJ313 29x45x8mm, ACM NJ311  35x54x8mm, NBR NJ312  80x100x10mm, MVQ				
	 JC404  JC405   JF021 10/83 → 12/86	JN605 (50-028111-00) 01/84 → 12/86	JJ271	PA529  (x4) PA630 (x4) PA528  (x4)	NJ311  35x54x8mm, NBR NJ312  80x100x10mm, MVQ				
	 JE625	JN757		PB156 (x16)	NJ254 27x43x9mm, NBR NJ311  35x54x8mm, NBR NJ312  80x100x10mm, MVQ				
	 JC404  JC405 	JN605 (50-028111-00)	JJ271	PA529  (x4) PA630 (x4) PA528  (x8)	NJ313 29x45x8mm, ACM NJ311  35x54x8mm, NBR NJ312  80x100x10mm, MVQ				
	 JC652  JC404  JC405   JF021	JN605 (50-028111-00)	JJ271	PA313 PA528 (x8)	NJ313 29x45x8mm, ACM NJ312  80x100x10mm, MVQ				
									
HBS284  (22-72003B) M12x1.50x198mm (x1) M12x1.50x163mm (x9)				PB355  (x8) PB356  (x8)	NJ134  NA5242  40x52x7mm NJ312  80x100x10mm, MVQ				
	 JC688   JF024 (x2)	JN649 (50-028117-00)	JJ390	PA531  (x8) PA528  (x8)	NJ254  (x2) 27x43x9mm, NBR NJ982  38x53x7mm, FPM NJ312  80x100x10mm, MVQ				
	 JC652  01/85 → 12/87 JC688   JF024 (x2) 01/88 →	JN649 (50-028117-00)	JJ365 → 12/87 JJ390 01/88 →	PA531  (x8) PA528  (x8)	NJ254  (x2) 27x43x9mm, NBR NJ982  38x53x7mm, FPM NJ312  80x100x10mm, MVQ				
HBS284  (22-72003B) M12x1.50x198mm (x1) M12x1.50x163mm (x9)		HM5266 		PB355  (x8) PB356  (x8)	NA5245 (x2) 29x43x8mm NA5242  40x52x7mm NJ312  80x100x10mm, MVQ				
									





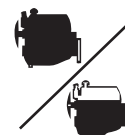



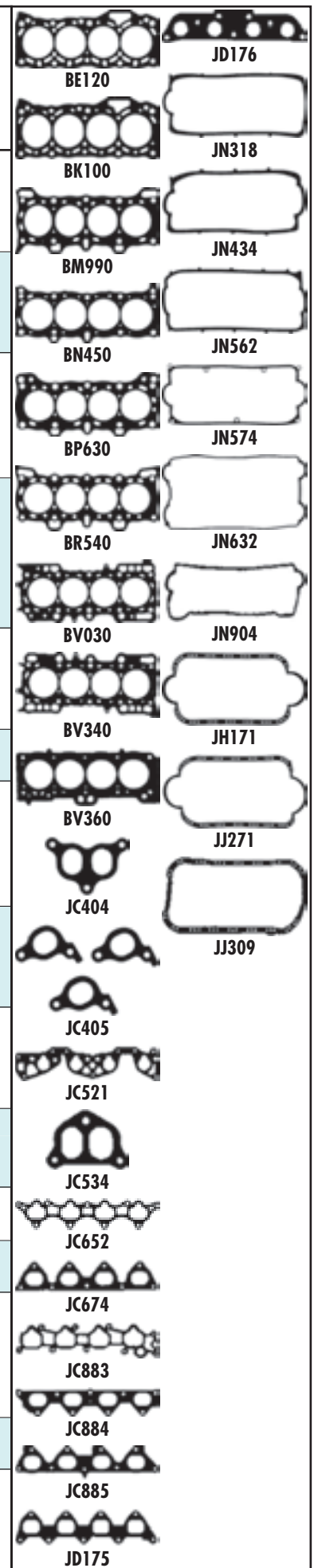

KW/PS



Model					Year Range	Power (KW/PS)	Engine Type	Accessories
Prelude Coupe 2.2L i 16V Vtec					02/93 → 09/96	142		
H22A2	2157	4	87.00	Injection, DOHC	136/185	BV340 (MLS)	DV340	
Prelude Coupe 2.3L i 16V					02/92 → 09/96	143		
H23A2	2259	4	87.00	Injection, DOHC	118/160	BV030 (MLS) (30-028168-00)	DV030	GV030
Quint 1.6L Integra					10/84 → 12/87	144		
ZC	1590	4	75.00	SOHC	77/105	BR540 (Graphite) (30-028137-00) 12/85 → BP630 (Graphite) 01/86 → 12/87	DP630 01/86 → 12/87	ES880 01/86 →
Quintet 1.6L CVCC					01/80 → 12/85	145		
EP	1602	4	77.00		66/89	BE120 (Graphite) 01/80 → 09/81 BK100 (Fibre) 10/81 →	DK100 (21-26212-22/0) 10/81 →	
Quintet 1.6L EX					02/80 → 12/84	146		
EL	1602	4	77.00	SOHC	60/81	BE120 (Graphite) → 12/81 BK100 (Fibre) 01/82 →	DK103 01/82 →	
S2000 Convertible 2.0L					06/99 →	147		
F20C VTEC	1997	4	87.00	Injection, DOHC	177/240	AG8010 (MLS)	CG8010	FG8010
Shuttle 1.3L 12V					01/84 → 10/87	148		
EV2	1342	4	74.00	SOHC	59/80	BM990 (Graphite) (30-026714-10)	DM995 (21-26714-22/0)	EM992 01/84 → 12/87 GM990 01/84 → 12/87
Shuttle 2.2L 16V					10/94 → 02/98	149		
F22B8	2156	4	85.00	Injection, SOHC	110/150	BV360 (MLS)	DV360 (21-28106-20/0)	
Shuttle 2.3L 16V					01/98 → 05/01	150		
F23A7	2254	4	86.00	SOHC	110/150	AG5780 (MLS)	CG5780	EG6210 (Rubber)
Stepwagon 2.0L					10/00 → 09/05	151		
Stepwagon 2.0L 4WD					10/00 → 09/05			
K20A9	1998	4	86.00		110/150			FG8131
Stepwagon 2.0L					10/05 →	152		
K20A6	1998	4	86.00	DOHC	114/155			EG5810
Stream 1.7L 16V					05/01 →	153		
D17A2	1668	4	75.00		92/125	AD5230 (MLS), 0.7mm	CG5792	
Stream 2.0L 16V					05/01 →	154		
K20A	1998	4	86.00	DOHC	114- 115/ 155- 156	AG5810 (MLS) K20A1	CG5810 K20A1 CG5811	EG5810
Torneo 2.0L					04/94 → 12/97	155		
F20Z2	1997	4	85.00	Injection, SOHC	85/116		DS705	
Vigor 2.0L 12v					01/85 → 12/89	156		
A20A1	1955	4	82.70	SOHC	75/102	BN450 (Graphite) (30-028115-00)	DN450	GN450

HBS284 ⊙ <i>[22-72003B]</i> M12x1.50x198mm (x1) M12x1.50x163mm (x9)	JC885 ■ ⊙ JF024 ■ (x2)	HM5266 ■ 01/97→		PB355 ■ (x8) PB356 ■ (x8)	NA5245 (x2) 29x43x8mm NA5242 ■ 40x52x7mm NJ312 ■ 80x100x10mm, MVQ		
HBS284 ⊙ <i>[22-72003B]</i> M12x1.50x198mm (x1) M12x1.50x163mm (x9)	JC883 ■ JC884 ■ ⊙ JF024 ■ (x2)			PA096 (x16) [117]	NJ134 ■ NA5242 ■ 40x52x7mm NJ312 ■ 80x100x10mm, MVQ		
	JC674 ■ ⊙ JE625	JN632 01/86→12/87	JJ309 01/86→	PA528 ■ (x8)	NJ254 27x43x9mm, NBR NJ381 ■ 31x46x8mm, NBR NJ312 ■ 80x100x10mm, MVQ		
	⊙ JE625 10/81→	JN318 01/80→10/81 JN434 10/81→	JH171	PA313 ■ (x4) PA373 (x4) [252] PA424 ■ (x4)	NJ254 27x43x9mm, NBR NJ072 ■ 35x50x8mm, NBR NJ073 ■ 74x98x12mm, MVQ →09/81 NJ309 ■ 76x98x12mm, NBR 10/81→		
		JN318 01/78→12/81 JN434 01/82→	JH171	PA424 ■ (x4) PA313 ■ (x4)	NJ254 27x43x9mm, NBR NJ072 ■ 35x50x8mm, NBR NJ073 ■ 74x98x12mm, MVQ		
		HM5258 ■					
	JC521 ■ 01/84→12/87 JC534 ■ ⊙ JE625	JN574 01/84→ JN562 <i>(50-026763-00)</i> 01/85→	JJ309	PA531 ■ (x4) PA630 (x4) PA528 ■ (x8)	NJ313 29x45x8mm, ACM NJ381 ■ 31x46x8mm, NBR NJ312 ■ 80x100x10mm, MVQ		
HBS284 ⊙ <i>[22-72003B]</i> M12x1.50x198mm (x1) M12x1.50x163mm (x9)	JD175 ■ JD176 ■	JN904		PB355 ■ (x8) PB356 ■ (x8)	NJ134 ■ NA5242 ■ 40x52x7mm NJ312 ■ 80x100x10mm, MVQ		
HBS281 ⊙ <i>[22-72001B]</i> M12x1.50x198mm (x1) M12x1.50x162mm (x9)	JD5749 ■			PB355 ■ (x8) PB356 ■ (x8)	NJ134 ■ NA5242 ■ 40x52x7mm NJ312 ■ 80x100x10mm, MVQ		
		HM5267 ■ K20A1					
	JC652 ■ JC404 ■ JC405 ■ ⊙ JE625	JN605 <i>(50-028111-00)</i>	JJ271	PA529 ■ (x4) PA528 ■ (x8)	NJ313 29x45x8mm, ACM NJ311 ■ 35x54x8mm, NBR NJ312 ■ 80x100x10mm, MVQ		



		CC			9			CC			9
4D56T	Diesel	2477	4	91.10	34	G4GC-G	Petrol	1975	4	82.00	19
4G61	Petrol	1596	4	82.30	18	G4GC-G	Petrol	1975	4	82.00	28
4G61	Petrol	1596	4	82.30	55	G4GC-G	Petrol	1975	4	82.00	29
6G72	Petrol	2972	6	91.10	38	G4GC-G	Petrol	1975	4	82.00	94
D3-EA	Diesel	1493	3	83.00	4	G4GF	Petrol	1975	4	82.00	21
D3-EA	Diesel	1493	3	83.00	41	G4GF	Petrol	1975	4	82.00	61
D3-EA	Diesel	1493	3	83.00	62	G4GM	Petrol	1795	4	82.00	58
D3-EA	Diesel	1493	3	83.00	7	G4GR	Petrol	1599	4	82.00	16
D4BA	Diesel	2477	4	91.10	35	G4GR	Petrol	1599	4	82.00	56
D4BA	Diesel	2477	4	91.10	49	G4HC	Petrol	999	4	66.00	11
D4BB	Diesel	2477	4	91.10	45	G4HC-E	Petrol	999	4	66.00	12
D4BB	Diesel	2477	4	91.10	50	G4HC-E	Petrol	999	4	66.00	13
D4BF	Diesel	2476	4	91.10	45	G4HD	Petrol	1086	4	67.00	14
D4BF	Diesel	2476	4	91.10	51	G4HD	Petrol	1086	4	67.00	39
D4BF	Diesel	2476	4	91.10	88	G4HG	Petrol	1086	4	67.00	15
D4BH	Diesel	2476	4	91.10	34	G4HG	Petrol	1086	4	67.00	52
D4BH	Diesel	2476	4	91.10	36	G4HG	Petrol	1086	4	67.00	74
D4BH	Diesel	2476	4	91.10	45	G4JP-EG	Petrol	1997	4	85.00	78
D4BH	Diesel	2476	4	91.10	46	G4JP-G	Petrol	1997	4	85.00	76
D4BH	Diesel	2476	4	91.10	47	G4JP-G	Petrol	1997	4	85.00	93
D4BH	Diesel	2476	4	91.10	89	G4JS-G	Petrol	2351	4	86.50	72
D4BX	Diesel	2477	4	91.10	49	G6AT	Petrol	2972	6	91.10	37
D4CB	Diesel	2497	4	91.00	48	G6AT	Petrol	2972	6	91.10	87
D4EA	Diesel	1991	4	83.00	30	G6BA-G	Petrol	2656	6	86.70	22
D4EA	Diesel	1991	4	83.00	31	G6BA-G	Petrol	2656	6	86.70	73
D4EA	Diesel	1991	4	83.00	71	G6BA-G	Petrol	2656	6	86.70	86
D4EA	Diesel	1991	4	83.00	95	G6BA-G	Petrol	2656	6	86.70	96
D4EA	Diesel	1991	4	83.00	97	G6BA-G	Petrol	2656	6	86.70	98
DJY	Diesel	1905	4	83.00	60	G6BV-G	Petrol	2493	6	84.00	85
G15B	Petrol	1468	4	75.50	33	G6CT-G	Petrol	2972	6	91.10	99
G15B	Petrol	1468	4	75.50	54	G6CU	Petrol	3497	6	93.00	100
G15B	Petrol	1468	4	75.50	66	G6CU	Petrol	3497	6	93.00	91
G15B	Petrol	1468	4	75.50	67	J3	Diesel	2902	4	97.10	90
G4BB	Petrol	1795	4	82.00	25						
G4BP	Petrol	1997	4	85.00	70						
G4CN	Petrol	1836	4	81.50	59						
G4CP	Petrol	1997	4	85.00	79						
G4CP	Petrol	1997	4	85.00	80						
G4CP-D	Petrol	1997	4	85.00	77						
G4CP-D	Petrol	1997	4	85.00	81						
G4CP-U	Petrol	1997	4	85.00	79						
G4CR	Petrol	1596	4	82.30	57						
G4DG	Petrol	1299	4	71.00	65						
G4DJ	Petrol	1468	4	75.50	33						
G4DJ	Petrol	1468	4	75.50	54						
G4DJ	Petrol	1468	4	75.50	66						
G4DJ	Petrol	1468	4	75.50	67						
G4E-A	Petrol	1341	4	71.50	1						
G4E-A	Petrol	1341	4	71.50	40						
G4EB	Petrol	1495	4	75.50	6						
G4EC-G	Petrol	1495	4	75.50	5						
G4ED-G	Petrol	1599	4	76.50	10						
G4ED-G	Petrol	1599	4	76.50	17						
G4ED-G	Petrol	1599	4	76.50	23						
G4ED-G	Petrol	1599	4	76.50	24						
G4ED-G	Petrol	1599	4	76.50	43						
G4ED-G	Petrol	1599	4	76.50	44						
G4ED-G	Petrol	1599	4	76.50	63						
G4ED-G	Petrol	1599	4	76.50	92						
G4EH	Petrol	1341	4	71.50	2						
G4EK	Petrol	1495	4	75.50	53						
G4EK	Petrol	1495	4	75.50	68						
G4EK	Petrol	1495	4	75.50	8						
G4EK-TC	Petrol	1495	4	75.50	68						
G4ER	Petrol	1495	4	75.50	42						
G4ER	Petrol	1495	4	75.50	9						
G4GB-G	Petrol	1795	4	82.00	64						
G4GC	Petrol	1975	4	82.00	26						
G4GC	Petrol	1975	4	82.00	27						

HYUNDAI



KW/PS

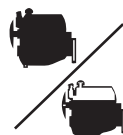

Model						Year Range	Engine Code	Displacement (L)	Cylinders	Power (kW/PS)	Configuration	Transmission	Accessories		
Accent 1.3L						01/00 →	1								
G4EA	1341	4	71.50	SOHC	55-63/ 75-86								BY730 (MLS), 0.85mm	DY735	GY735
Accent 1.3L						10/94 → 01/00	2								
Accent 1.3L i 12V						10/94 → 01/00									
G4EH	1341	4	71.50	MPI, SOHC	61/83 62/84								BY730 (MLS), 0.85mm	DY730	GY735
Accent 1.3L						08/02 →	3								
	1341	4			62/84								BY730 (MLS), 0.85mm		
Accent 1.5L CRDi Diesel						04/02 →	4								
D3-EA	1493	3	83.00	Direct Injection, SOHC	60/81									CG7910	FG7910
Accent 1.5L						09/00 →	5								
G4EC-G	1495	4	75.50	DOHC	75/102								AG6040 (MLS) G4K	CG6040 G4K	FG6040 G4K
Accent 1.5L						01/00 →	6								
G4EB	1495	4	75.50	SOHC	66/89								BY730 (MLS), 0.85mm	DY730	
Accent 1.5L CRDi Diesel						01/02 →	7								
D3-EA	1493	3	83.00	Direct Injection, SOHC	60/81								AG7910 (MLS)	CG7910	FG7910
Accent 1.5L i 12V						10/94 → 01/00	8								
G4EK	1495	4	75.50	MPI, SOHC	66/89								BY730 (MLS), 0.85mm	DY730	
Accent 1.5L i 16V						10/95 → 01/00	9								
G4ER	1495	4	75.50	MPI, DOHC	73/99								AG6040 (MLS) 01/96 → G4K	CG6040 01/96 → G4K	FG6040 01/96 → G4K
Accent 1.6L						12/02 →	10								
G4ED-G	1599	4	76.50	DOHC	76-79/ 103- 107								AG8290 (Fibre), 1.4mm	CG8291	FG8291
Atos 1.0L i						02/98 → 03/02	11								
G4HC	999	4	66.00	SOHC	40/54								AG8050 (Fibre) G4HC	CG5360	FG8050 G4HC
Atos 1.0L i						03/01 →	12								
G4HC-E	999	4	66.00	Injection, SOHC	43/58								AG8050 (Fibre) G4HC	CG5360	FG8050 G4HC
Atos 1.0L i						03/01 →	13								
G4HC-E	999	4	66.00	Injection, SOHC	43/58								AG8050 (Fibre) G4HC	CG5360	FG8050 G4HC
Atos 1.1L						06/03 → 05/05	14								
G4HD	1086	4	67.00		43-46/ 59-63								AG8060 (MLS)	CG8060	FG8060
Atos 1.1L						03/04 →	15								
G4HG	1086	4	67.00	Injection, SOHC	46-48/ 63-65										
Coupe 1.6L 16V						03/98 → 04/02	16								
G4GR	1599	4	82.00	Injection, DOHC	66-85/ 90-116									DY710	FG8040
Coupe 1.6L 16V						03/02 →	17								
G4ED-G	1599	4	76.50	DOHC	76-79/ 103- 107								AG8290 (Fibre), 1.4mm	CG8291	FG8291
Coupe 1.6L i 16V						12/96 → 04/02	18								
4G61	1596	4	82.30	DOHC	84/114									DY710	
Coupe 2.0L						03/02 →	19								
Coupe 2.0L GLS						02/03 →									
G4GC-G	1975	4	82.00	DOHC	100- 102/ 136- 139										

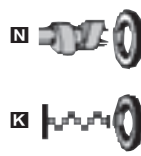
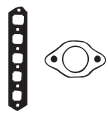

BY730

HBS387 Ⓢ (22-76020B)	JD5751 Ⓢ	JM5277				
HBS387 Ⓢ (22-76020B)	JD5751 Ⓢ	JM5277				
HBS435 Ⓢ (22-76012B)	JD5751 Ⓢ	JM5277				
HBS483 (22-76026B)		HM5250 Ⓢ				
HBS454 Ⓢ (22-76015B) M10x1,25x95,0mm (x10)	JD5776 Ⓢ	HM5259 Ⓢ G4K				
	JD5751 Ⓢ	JM5277 HM5261 Ⓢ				
HBS483 (22-76026B)		HM5250 Ⓢ				
HBS387 Ⓢ (22-76020B)	JD5751 Ⓢ	JM5277				
HBS454 Ⓢ (22-76015B) M10x1,25x95,0mm (x10)	JD5776 Ⓢ	HM5259 Ⓢ 01/96→ G4K				
HBS454 Ⓢ (22-76015B) M10x1,25x95,0mm (x10)	JD5776 Ⓢ	HM5261 Ⓢ HM5262 Ⓢ				
HBS378 Ⓢ (22-76007B) M10x1,25x106,5mm (x10)	JD5900 Ⓢ JD5899 Ⓢ (MLS)	JM5305 G4HC JM5306				
HBS378 Ⓢ (22-76007B) M10x1,25x106,5mm (x10)	JD5899 Ⓢ (MLS)	JM5305 G4HC JM5306				
HBS378 Ⓢ (22-76007B) M10x1,25x106,5mm (x10)	JD5899 Ⓢ (MLS)	JM5305 G4HC JM5306 (x2)				
HBS378 Ⓢ (22-76007B) M10x1,25x106,5mm (x10)	JD5900 Ⓢ	JM5306				
		JM5306				
HBS308 Ⓢ (22-76005B) M10x1,25x99mm (x8) M12x1,25x151mm (x2)	JD5777 Ⓢ JD5778 Ⓢ					
HBS454 Ⓢ (22-76015B) M10x1,25x95,0mm (x10)		HM5261 Ⓢ				
HBS308 Ⓢ (22-76005B) M10x1,25x99mm (x8) M12x1,25x151mm (x2)	JD5777 Ⓢ JD5778 Ⓢ					
HBS308 Ⓢ (22-76005B) M10x1,25x99mm (x8) M12x1,25x151mm (x2)	JD5778 Ⓢ	HM5272 Ⓢ				



KW/PS

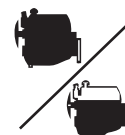

Coupe 2.0L 16V		03/01 → 04/02		20		AG8030 (MLS)	
	1975	4			99/135		09/01 →
Coupe 2.0L 16V		08/96 → 04/02		21		AG5070 (MLS), 0.8mm	
G4GF	1975	4	82.00	Injection, DOHC	102/139		CG5950 G4GF
Coupe 2.7L V6		03/02 →		22			
G6BA-G	2656	6	86.70	DOHC, V6	123- 127/ 167- 173		FG5690
Elantra 1.6L		06/00 →		23		AG8290 (Fibre), 1.4mm	
G4ED-G	1599	4	76.50	DOHC	76-79/ 103- 107		CG8290 FG8290
Elantra 1.6L		05/03 →		24		AG8290 (Fibre), 1.4mm	
G4ED-G	1599	4	76.50	DOHC	76-79/ 103- 107		CG8290 FG8290
Elantra 1.8L		06/00 →		25		AG8030 (MLS)	
G4BB	1795	4	82.00		97/132	G4GB	CG8030 G4GB
Elantra 2.0L		06/00 →		26		AG5070 (MLS), 0.8mm	
G4GC	1975	4	82.00	Injection, DOHC	104- 105/ 141- 143		CG5950 G4GF
Elantra 2.0L		06/00 →		27		AG8030 (MLS)	
G4GC	1975	4	82.00	Injection, DOHC	104- 105/ 141- 143	G4GC	CG8030 G4GC
Elantra 2.0L		06/00 →		28		AG8030 (MLS)	
G4GC-G	1975	4	82.00	DOHC	100- 102/ 136- 139	G4GC	CG8030 G4GC
Elantra 2.0L		06/00 →		29		AG5070 (MLS), 0.8mm	
G4GC-G	1975	4	82.00	DOHC	100- 102/ 136- 139		CG5950 G4GF
Elantra 2.0L CRDi Diesel		04/01 →		30			
D4EA	1991	4	83.00	Direct Injection, SOHC	83/113		
Elantra 2.0L CRDi Diesel		04/01 →		31		AG7920 (MLS), 1.10mm AG7930 (MLS), 1.20mm AG7940 (MLS), 1.30mm	
D4EA	1991	4	83.00	Direct Injection, SOHC	83/113		CG7920▲
Excel 1.3L		01/90 → 01/95		32		BN330 (Graphite)	
	1299	4			49/67	(30-028175-00)	DN332
Excel 1.5L		01/90 → 01/95		33		BT430 (Graphite)	
G15B	1468	4	75.50	SOHC	53/72		DT430
G4DJ	1468	4	75.50	SOHC	53-63/ 72-86	(30-028224-00)	(21-28224-20/0)

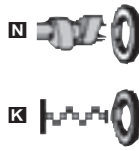
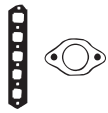

BN330



BT430

HBS308 ® (22-76005B) M10x1.25x99mm (x8) M12x1.25x151mm (x2)	JD5778 ■					
HBS308 ® (22-76005B) M10x1.25x99mm (x8) M12x1.25x151mm (x2)	JD5777 ■ JD5778 ■					
HBS446 01/99 →		HM5265 ■ (x2)				
HBS454 ® (22-76015B) M10x1,25x95.0mm (x10)	JD5777 ■ JD5778 ■	HM5260 ■				
HBS454 ® (22-76015B) M10x1,25x95.0mm (x10)		HM5260 ■				
HBS308 ® (22-76005B) M10x1.25x99mm (x8) M12x1.25x151mm (x2)	JD5778 ■					
HBS308 ® (22-76005B) M10x1.25x99mm (x8) M12x1.25x151mm (x2)	JD5777 ■ JD5778 ■					
HBS308 ® (22-76005B) M10x1.25x99mm (x8) M12x1.25x151mm (x2)	JD5778 ■					
HBS308 ® (22-76005B) M10x1.25x99mm (x8) M12x1.25x151mm (x2)	JD5778 ■	HM5272 ■				
HBS308 ® (22-76005B) M10x1.25x99mm (x8) M12x1.25x151mm (x2)	JD5777 ■ JD5778 ■	HM5272 ■				
HBS382 ® (22-76010B) M12x1.50x183mm (x10)						
HBS382 ® (22-76010B) M12x1.50x183mm (x10)		HM5251 ■				
HBS440 (22-76022B) M10x1.25x100.0mm (x10)						



KW/PS



Galloper 2.5L TCi D Diesel						08/98 →	34	BS130 (Graphite), 1,50mm (30-028225-00)	DS130 (21-28225-20/0)	
Galloper 2.5L TD Diesel						08/91 → 07/98				
Galloper 2.5L TD intercooler Diesel						08/91 → 07/98				
D4BH	2476	4	91.10	Indirect Injection	73/99					
4D56T	2477	4	91.10	SOHC	62-70/ 84-95					
Galloper 2.5L TD Diesel						08/98 →	35	BS130 (Graphite), 1,50mm (30-028225-00)	DS130 (21-28225-20/0)	EJ603
D4BA	2477	4	91.10	Indirect Injection, SOHC	55-57/ 75-78					
Galloper 2.5L TD intercooler Diesel						08/98 →	36	BS130 (Graphite), 1,50mm (30-028225-00)	DS130 (21-28225-20/0)	GS130 (20-28225-00/0)
D4BH	2476	4	91.10	Indirect Injection	73/99					
Galloper 3.0L V6						08/98 →	37	BR600 (Graphite) (x2) (30-028200-00)		
G6AT	2972	6	91.10	Injection, SOHC, V6	104- 107/ 140- 146					
Galloper 3.0L V6						08/91 → 07/98	38	BR600 (Graphite) (30-028200-00)		
6672	2972	6	91.10	SOHC, V6	104/141					
Getz 1.1L						09/02 →	39	AG8060 (MLS)	CG8060	FG8060
G4HD	1086	4	67.00		43-46/ 59-63					
Getz 1.3L						09/02 →	40	BY730 (MLS), 0.85mm	DY735	GY735
G4EA	1341	4	71.50	SOHC	55-63/ 75-86					
Getz 1.5L CRDi Diesel						01/03 →	41		CG7910	FG7910
D3-EA	1493	3	83.00	Direct Injection, SOHC	60/81					
Getz 1.5L GL						08/02 → 07/05	42			FG6040
G4ER	1495	4	75.50	MPi, DOHC	73/99					
Getz 1.6L						08/05 →	43			
G4ED-G	1599	4	76.50	DOHC	76-79/ 103- 107					
Getz 1.6L						09/02 →	44	AG8290 (Fibre), 1.4mm		
G4ED-G	1599	4	76.50	DOHC	76-79/ 103- 107					
H-1 2.5L D Diesel						10/97 →	45	BS130 (Graphite), 1,50mm (30-028225-00)	DS130 (21-28225-20/0)	EJ603
H-1 2.5L TD Diesel						10/97 →				
H-1 Van 2.5L TD Diesel						03/00 → 09/00				
D4BF	2476	4	91.10	Indirect Injection, SOHC	59/80					
D4BH	2476	4	91.10	Indirect Injection	73/99					
D4BB	2477	4	91.10	Indirect Injection, SOHC	57/77					
H-1 2.5L TD Diesel						10/99 → 11/01	46	BS130 (Graphite), 1,50mm (30-028225-00)	DS130 (21-28225-20/0)	EJ603 GS130 (20-28225-00/0)
H-1 Van 2.5L TD Diesel						03/00 →				
D4BH	2476	4	91.10	Indirect Injection	73/99					
H-1 2.5L TD Diesel						11/01 →	47	BS130 (Graphite), 1,50mm (30-028225-00)	DS130 (21-28225-20/0)	
D4BH	2476	4	91.10	Indirect Injection	73/99					
H-1 Van 2.5L CRDi Diesel						08/03 →	48			
D4CB	2497	4	91.00	Direct Injection	103- 125/ 140- 170					

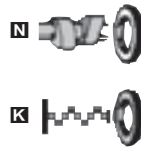
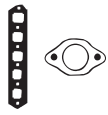

BR600



BS130



BY730



JC224



JN403



JJ072

HBS295 ® (22-70013B) M12x1.25x104mm (x18)		JN403 (50-026769-00)			
HBS295 ® (22-70013B) M12x1.25x104mm (x18)		JN403 (50-026769-00)			
HBS295 ® (22-70013B) M12x1.25x104mm (x18)	JC224	JN403 (50-026769-00)	JJ072		
HBS402 (22-76018B) 01/90 →					
HBS402 (22-76018B)					
HBS378 ® (22-76007B) M10x1.25x106.5mm (x10)	JD5900 ■	JM5306			
HBS387 ◎ (22-76020B)	JD5751 ■	JM5277			
HBS483 (22-76026B)		HM5250 ■			
HBS454 ® (22-76015B) M10x1.25x95.0mm (x10)					
HBS454 ® (22-76015B) M10x1.25x95.0mm (x10)		HM5261 ■			
HBS295 ® (22-70013B) M12x1.25x104mm (x18)		JN403 (50-026769-00)			
HBS295 ® (22-70013B) M12x1.25x104mm (x18)	JC224	JN403 (50-026769-00)	JJ072		
HBS295 ® (22-70013B) M12x1.25x104mm (x18)					
HBS434 (22-76011B) M12x1.25x152.0mm (x18)					



KW/PS

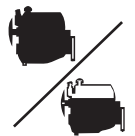

H100 2.5L D Diesel 07/93 → 12/94 49						BS130 (Graphite), 1,50mm (30-028225-00)	DS130 (21-28225-20/0)	EJ603 GS130 (20-28225-00/0)		
H100 Van 2.5L D Diesel 07/93 → 12/94										
D4BX	2477	4	91.10	Indirect Injection	54-55/ 73-75					
D4BA	2477	4	91.10	Indirect Injection, SOHC	55-57/ 75-78					
H100 2.5L D Diesel 12/94 → 03/00 50						BS130 (Graphite), 1,50mm (30-028225-00)	DS130 (21-28225-20/0)	EJ603		
H100 Van 2.5L D Diesel 12/94 → 03/00										
D4BB	2477	4	91.10	Indirect Injection, SOHC	57/77					
H100 2.5L TD Diesel 07/93 → 03/00 51						BS130 (Graphite), 1,50mm (30-028225-00)	DS130 (21-28225-20/0)			
D4BF	2476	4	91.10	Indirect Injection, SOHC	59/80					
i10 1.1L 01/08 → 52										
G4HG	1086	4	67.00	Injection, SOHC	46-48/ 63-65					
Lantra 1.5L 12V 12/96 → 09/00 53						BY730 (MLS), 0.85mm				
G4EK	1495	4	75.50	MPi, SOHC	66/89					
Lantra 1.5L i.e. 10/90 → 11/95 54						BT430 (Graphite) (30-028224-00)	DT430 (21-28224-20/0)			
G15B	1468	4	75.50	SOHC	53/72					
G4DJ	1468	4	75.50	SOHC	53-63/ 72-86					
Lantra 1.6L 16V 11/95 → 09/00 55							DY710			
4G61	1596	4	82.30	DOHC	84/114					
Lantra 1.6L i 11/95 → 09/00 56							DY710	FG8040		
G4GR	1599	4	82.00	Injection, DOHC	66-85/ 90-116					
Lantra 1.6L i.e. 16V 10/90 → 11/95 57						BS240 (Graphite) (30-028197-00)	DS240 01/90 → 12/92 DS241 (21-28197-21/0) 01/93 → 12/95	GS240 01/90 → 12/92 GS241 (20-28197-01/0) 01/93 → 12/95		
G4CR	1596	4	82.30	Injection, DOHC	78-84/ 106- 114					
Lantra 1.8L 16V 11/95 → 09/00 58						AG5070 (MLS), 0.8mm			CG5950 → 12/97 G4DM	
G4GM	1795	4	82.00	DOHC	94/128					
Lantra 1.8L i.e. 16V 10/90 → 11/95 59						BS240 (Graphite) (30-028197-00)	DS240			
G4CN	1836	4	81.50	Injection, DOHC	93/126					
Lantra 1.9L D Diesel 03/98 → 09/00 60						BX880 (Fibre), 1.36mm, 1 Notch (30-028475-00) ⊖0.56 → 0.67mm	DJ720▲ (21-25202-22/0)			
DJY	1905	4	83.00		50-52/ 68-71					
Lantra 2.0L 16V 08/96 → 09/00 61						AG5070 (MLS), 0.8mm	CG5950 01/97 → G4GF			
G4GF	1975	4	82.00	Injection, DOHC	102/139					
Matrix 1.5L CRDi Diesel 10/01 → 62							CG7910	FG7910		
D3-EA	1493	3	83.00	Direct Injection, SOHC	60/81					
Matrix 1.6L 06/01 → 63						AG8290 (Fibre), 1.4mm	CG8290	FG8290		
G4ED-G	1599	4	76.50	DOHC	76-79/ 103- 107					
Matrix 1.8L 06/01 → 64						AG8030 (MLS) 09/01 →				
G4GB-G	1795	4	82.00		90/122					
Pony 1.3L 10/89 → 01/95 65						BN330 (Graphite) (30-028175-00)	DN332			
G4DG	1299	4	71.00		49/67 43/58					

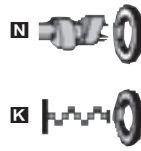
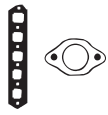

BN330



BS130



BS240



BT430



BX880



BY730



JC224



JC794



JC795

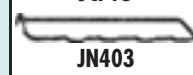

JN403



JN715



JJ072

HBS295®
(22-70013B)
M12x1.25x104mm (x18)

JC224

JN403
(50-026769-00)

JJ072

HBS295®
(22-70013B)
M12x1.25x104mm (x18)

HBS295®
(22-70013B)
M12x1.25x104mm (x18)

JN403
(50-026769-00)

JM5306

HBS387®
(22-76020B)

JD5751

JM5277

HBS440
(22-76022B)
M10x1.25x100.0mm (x10)

HBS308®
(22-76005B)
M10x1.25x99mm (x8)
M12x1.25x151mm (x2)

JD5777
JD5778

HBS308®
(22-76005B)
M10x1.25x99mm (x8)
M12x1.25x151mm (x2)

JD5777
JD5778

HBS308®
(22-76005B)
M10x1.25x99mm (x8)
M12x1.25x151mm (x2)

JC795
JC794

JN715
(50-028198-00)

PA968 (x16)

☑ NJ242 35x50x8mm, NBR
☑ NJ005 44x60x7mm, NBR
☑ NJ251 80x96x9mm, MVQ

HBS308®
(22-76005B)
M10x1.25x99mm (x8)
M12x1.25x151mm (x2)

JD5777
JD5778

HBS084®
(22-15005B)
M12x1.50x123mm (x10)

HBS308®
(22-76005B)
M10x1.25x99mm (x8)
M12x1.25x151mm (x2)

JD5777
JD5778

HBS483
(22-76026B)

HM5250

HBS454®
(22-76015B)
M10x1,25x95.0mm (x10)

HM5260
09/01 →
G4ED

HBS308®
(22-76005B)
M10x1.25x99mm (x8)
M12x1.25x151mm (x2)



KW/PS

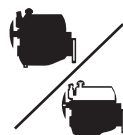

Pony 1.5L 10/85 → 01/95 66						BT430 (Graphite) (30-028224-00)	DT430 (21-28224-20/0)	
Pony 1.5L i 10/89 → 01/95								
G15B	1468	4	75.50	SOHC	53/72			
G4DJ	1468	4	75.50	SOHC	53-63/ 72-86			
S Coupe Coupe 1.5L i 02/90 → 05/96 67						BT430 (Graphite) (30-028224-00)	DT430 (21-28224-20/0)	
S Coupe Coupe 1.5L i 04/92 → 05/96 68								
G15B	1468	4	75.50	SOHC	53/72			
G4DJ	1468	4	75.50	SOHC	53-63/ 72-86			
S Coupe Coupe 1.5L i Turbo 04/91 → 05/96 68						BY730 (MLS), 0.85mm	DY730	
S Coupe Coupe 1.5L i Turbo 04/91 → 05/96								
G4EK	1495	4	75.50	MPI, SOHC	66/89			
G4EK-TC	1495	4	75.50	Injection	85/116			
Santa Fé 2.0L CRDi 4x4 Diesel 08/03 → 69								
Santa Fé 2.0L 08/01 → 70								
	1991	4			92/125			
Santa Fé 2.0L 08/01 → 70								
G4BP	1997	4	85.00		99/135	AF5430 (MLS) G4JPI	CF5430 G4JPI	
Santa Fé 2.0L CRDi Diesel 08/01 → 71								
Santa Fé 2.0L CRDi 4x4 Diesel 04/01 →						AG7930 (MLS), 1.20mm AG7940 (MLS), 1.30mm	CG7920▲	
Santa Fé 2.0L CRDi 4x4 Diesel 04/01 →								
D4EA	1991	4	83.00	Direct Injection, SOHC	83/113	AF5070 (MLS) SIRIUSII	CF5070▲	FF5070
Santa Fé 2.4L 16V 02/01 → 72								
Santa Fé 2.4L 16V 4x4 02/01 →								
G4JS-G	2351	4	86.50	DOHC	100- 107/ 136- 146			
Santa Fé 2.7L V6 4x4 02/01 → 73						AG5690 (MLS) G6BA AF5060 (MLS) G6BA	CG5690 G6BA	FG5690 G6BA
Santa Fé 2.7L V6 4x4 02/01 →								
G6BA-G	2656	6	86.70	DOHC, V6	123- 127/ 167- 173			
Santro 1.1L 06/05 → 74								
G4HG	1086	4	67.00	Injection, SOHC	46-48/ 63-65	BL450 (Graphite)	DL450	
Sonata 1.8L i 09/88 → 06/98 75								
	1796	4			70/95			
	1796	4			72/98			
Sonata 2.0L 16V Mk III 06/98 → 10/01 76								
Sonata 2.0L i 16V Mk II 05/93 → 06/98 77								
G4JP-G	1997	4	85.00	DOHC	100/136			
Sonata 2.0L 10/01 → 11/04 78								
G4JP-D	1997	4	85.00	Injection, DOHC	96-102/ 131- 139	AF5430 (MLS) G43P	CF5430 G43P	
Sonata 2.0L i 09/88 → 06/98 79								
G4CP	1997	4	85.00	Injection, OHV	77/105	BS120 (Graphite) (30-028203-00)	DS120 (21-28203-20/0)	
G4CP-U	1997	4	85.00	Injection	80/109			
Sonata 2.0L i 06/94 → 08/96 80						BS120 (Graphite) (30-028203-00)		
Sonata 2.0L i 16V 01/91 → 10/93 81								
G4CP	1997	4	85.00	Injection, OHV	77/105	BS120 (Graphite) (30-028203-00)		
Sonata 2.4L 01/05 → 82								
G4CP-D	1997	4	85.00	Injection, DOHC	96-102/ 131- 139	AF5070 (MLS) SIRIUSII	CF5070▲	FF5070
	2359	4			119/162			

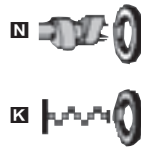
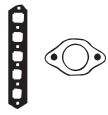

BL450



BS120



BT430



BY730

HBS440
(22-76022B)
M10x1.25x100.0mm (x10)

HBS440
(22-76022B)
M10x1.25x100.0mm (x10)

HBS387⊙
(22-76020B)

JD5751

JM5277

HBS382⊙
(22-76010B)
M12x1.50x183mm (x10)

HBS418
M11x1.25x97mm (x10)

HM5272

NK143 85x103x8mm, FPM

HBS382⊙
(22-76010B)
M12x1.50x183mm (x10)

HBS418
M11x1.25x97mm (x10)

HM5272

NK143 85x103x8mm, FPM

HBS446
01/99 →

HM5265 (x2)
G6BA

JM5306

HBS354⊙
(22-76006B)
M11x1.25x97mm (x10)

HM5272

HBS307⊙
(22-76004B)
M12x1.25x104mm (x10)

HBS418
M11x1.25x97mm (x10)

HM5272

NK143 85x103x8mm, FPM

HBS307⊙
(22-76004B)
M12x1.25x104mm (x10)

HBS418
M11x1.25x97mm (x10)

HM5272

NK143 85x103x8mm, FPM

HYUNDAI



KW/PS

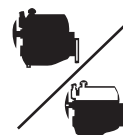

Sonata 2.4L 16V					03/98 → 10/01	83	AF5070 (MLS)	CF5070▲	FF5070
	2351	4				105/143	01/01 → SIRIUS II		
Sonata 2.4L i					09/88 → 08/91	84			
	2351	4				83/113			
Sonata 2.5L V6 24V					06/98 → 10/01	85	BZ280 (MLS) ☒	DZ280	
G6BV-G	2493	6	84.00	DOHC, V6		118/160	BZ290 (MLS) ☒		
Sonata 2.7L V6					10/01 → 11/04	86	AG5690 (MLS) ☒	CG5690	FG5690
G6BA-G	2656	6	86.70	DOHC, V6		123- 127/ 167- 173	AF5060 (MLS) ☒		
Sonata 3.0L i V6					01/91 → 06/98	87	BR600 (Graphite) (x2)		GR600
G6AT	2972	6	91.10	Injection, SOHC, V6		104- 107/ 140- 146	(30-028200-00)		
Starex 2.5L TD Diesel					06/97 →	88	BS130 (Graphite), 1,50mm	DS130	EJ603
Starex 2.5L TD 4WD Diesel					02/98 →		(30-028225-00)	(21-28225-20/0)	
D4BF	2476	4	91.10	Indirect Injection, SOHC		59/80			
Terracan 2.5L TD Diesel					12/01 →	89	BS130 (Graphite), 1,50mm		
D4BH	2476	4	91.10	Indirect Injection		73/99	(30-028225-00)		
Terracan 2.9L CRDi Diesel					12/01 →	90	BS130 (Graphite), 1,50mm		
J3	2902	4	97.10	Direct Injection		120/163	(30-028225-00)		
Terracan 3.5L i V6 4WD					12/01 →	91			
G6CU	3497	6	93.00	V6		143- 145/ 194- 197			
Tiburon Coupe 1.6L CVT					10/06 →	92	AG8290 (Fibre), 1.4mm	CG8290	FG8291
G4ED-G	1599	4	76.50	DOHC		76-79/ 103- 107			
Trajjet 2.0L					03/00 →	93	AF5430 (MLS)	CF5430	
G4JP-G	1997	4	85.00	DOHC		100/136	G4JP	G4JP	
Trajjet 2.0L					01/04 →	94	AF5430 (MLS)	CF5430	
G4GC-G	1975	4	82.00	DOHC		100- 102/ 136- 139	G4JP	G4JP	
Trajjet 2.0L CRDi Diesel					04/01 →	95	AG7930 (MLS), 1.20mm	CG7920▲	
D4EA	1991	4	83.00	Direct Injection, SOHC		83/113	AG7940 (MLS), 1.30mm		
Trajjet 2.7L V6					09/00 →	96	AG5690 (MLS) ☒	CG5690	FG5690
G6BA-G	2656	6	86.70	DOHC, V6		123- 127/ 167- 173	G6BA AF5060 (MLS) ☒ G6BA	G6BA G6BA	
Tucson 2.0L CRDi Diesel					08/04 →	97	AG7930 (MLS), 1.20mm	CG7920▲	
Tucson 2.0L CRDi All-wheel Drive Diesel					08/04 →		AG7940 (MLS), 1.30mm		
4WD									
D4EA	1991	4	83.00	Direct Injection, SOHC		83/113			

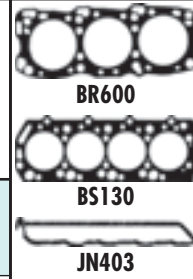
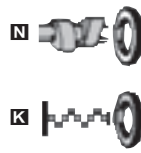
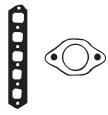

HBS418 M11x1.25x97mm (x10)		HM5272			<input checked="" type="checkbox"/> NK143 85x103x8mm, FPM	
HBS307 ® (22-76004B) M12x1.25x104mm (x10)						
HBS446 01/99→						
HBS446 01/99→		HM5265 (x2)				
HBS402 (22-76018B) 01/90→						
HBS295 ® (22-70013B) M12x1.25x104mm (x18)		JN403 (50-026769-00)				
HBS295 ® (22-70013B) M12x1.25x104mm (x18)						
HBS379 ® (22-76008B) M12x1.25x131mm (x10) M12x1.25x92mm (x8)						
		HM5264 (x2)				
HBS454 ® (22-76015B) M10x1.25x95.0mm (x10)						
HBS354 ® (22-76006B) M11x1.25x97mm (x10)		HM5272			<input checked="" type="checkbox"/> NK143 85x103x8mm, FPM	
HBS418 M11x1.25x97mm (x10)		HM5272			<input checked="" type="checkbox"/> NK143 85x103x8mm, FPM	
HBS382 ® (22-76010B) M12x1.50x183mm (x10)						
HBS446		HM5265 (x2) G6BA				
HBS381 ® (22-76009B) M12x1.50x183mm (x10)						







HYUNDAI

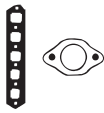

KW/PS

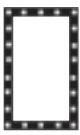

Tucson 2.7L Allrad					08/04 →	98			FG5690
G6BA-G	2656	6	86.70	DOHC, V6		123- 127/ 167- 173			
XG 300					12/98 →	99	AG8090 (Graphite) (x2)	CG8090	FG8090
G6CT-G	2972	6	91.10	V6		138/188	04/99 → G6CT	04/99 → G6CT	04/99 → G6CT
XG 350					04/03 →	100			
G6CU	3497	6	93.00	V6		143- 145/ 194- 197			

							 		
HBS446									
			HM5264 (x2) 04/99 → G6CT						
			HM5264 (x2)						



KW/PS



Model		Year	Cyl	Vol (L)	Power (kW/PS)	Code	Notes	Part	Part
FX 3.5L		01/03 →				1			
VQ35DE	3498	6	95.50	DOHC, V6	206/280		AE5910 (MLS) AG6130 (MLS)	CG5882	EG8230
G20 2.0L		01/90 → 12/97				2			
SR20DE	1998	4	86.00	DOHC	85/115		BV540 (Fibre)	DV541	EV540
I30 3.0L		01/97 →				3			
VQ30DE	2988	6	93.00	Injection, DOHC, V6	142/193		AF5710 (MLS), 0.70mm AF5700 (MLS), 0.70mm AF5730 (MLS) 01/00 → AF5720 (MLS) 01/00 →	CF5700 CF5720 01/00 →	
M35 3.5L Luxury		01/05 →				4			
VQ35DE	3498	6	95.50	DOHC, V6	206/280		AE5910 (MLS) AG6130 (MLS)	CG5882	EG8230
M35 3.5L Luxury Allrad		01/05 →				5			
VQ35DE	3498	6	95.50	DOHC, V6	206/280		AF5730 (MLS) VQ30DE AF5710 (MLS), 0.70mm AF5720 (MLS) VQ30DE AF5700 (MLS), 0.70mm	CG5882	
Q45 4.1L		01/93 →				6			
VH41DE	4130	8	93.00	DOHC, V8	205/278		BS830 (Graphite) BS840 (Graphite)		
Q45 4.5L		01/89 → 12/93				7			
VH45DE	4494	8	93.00	DOHC, V8	205/278		BS830 (Graphite) BS840 (Graphite)		
QX4 3.3L		01/97 →				8			
VG33E	3275	6	91.50	Injection, SOHC, V6	125/170		AF5690 (Graphite) (x2) VG33E	CF5690	FF5690

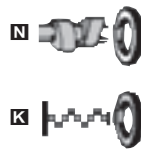
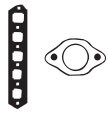

BS830



BS840



BV540

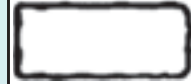

JN798

		JM5316				
		JM5317				
HBS188® (22-70002B) M11x1.50x157mm (x10)		JN798		HR767	<input checked="" type="checkbox"/> NJ106 40x62x10mm, NBR <input checked="" type="checkbox"/> NJ284 84x104x11mm, FPM	
		JM7037				
		JM5317				
		JM5316				
		JM7037				



CC



9



CC



9

4 JG2 T	Diesel	3059	4	95.40	50
4 JX1	Diesel	2999	4	95.40	49
4BC2	Diesel	3268	4	102.00	17
4BC2	Diesel	3268	4	102.00	19
4BC2	Diesel	3268	4	102.00	21
4EC1	Diesel	1488	4	76.00	27
4EC1T	Diesel	1488	4	76.00	27
4EC1T	Diesel	1488	4	76.00	33
4EC1T	Diesel	1488	4	76.00	40
4FB1T	Diesel	1817	4	84.00	31
4FC1	Diesel	1995	4	84.00	24
4FC1	Diesel	1995	4	84.00	9
4FC1T	Diesel	1995	4	84.00	23
4FC1T	Diesel	1995	4	84.00	37
4FC1T	Diesel	1995	4	84.00	8
4FD1	Diesel	2189	4	88.00	22
4FD1	Diesel	2189	4	88.00	38
4FG1T	Diesel	2380	4	89.30	39
4JA1	Diesel	2499	4	93.00	14
4JA1	Diesel	2499	4	93.00	18
4JB1	Diesel	2771	4	93.00	20
4JB1	Diesel	2771	4	93.00	7
4JB1T	Diesel	2772	4	93.00	47
4JB1TC	Diesel	2752	4	93.00	48
4JX1T	Diesel	2999	4	95.40	49
4XC1	Petrol	1471	4	77.00	26
4XC1	Petrol	1471	4	77.00	32
4XE1	Petrol	1588	4	80.00	28
4ZB1	Petrol	1818	4	84.00	53
4ZC1	Petrol	1995	4	88.00	3
4ZD1	Petrol	2254	4	89.30	12
4ZD1	Petrol	2254	4	89.30	45
4ZD1	Petrol	2254	4	89.30	5
4ZE1	Petrol	2559	4	92.60	46
4ZE1	Petrol	2559	4	92.60	6
6 VE1	Petrol	3494	6	93.40	52
6VD1	Petrol	3165	6	93.40	51
C190	Diesel	1951	4	86.00	15
C190	Diesel	1951	4	86.00	2
C190	Diesel	1951	4	86.00	25
C190	Diesel	1951	4	86.00	35
C223	Diesel	2238	4	88.00	13
C223	Diesel	2238	4	88.00	43
C223T	Diesel	2238	4	88.00	10
C223T	Diesel	2238	4	88.00	36
C223T	Diesel	2238	4	88.00	41
C223T	Diesel	2238	4	88.00	43
C223T	Diesel	2238	4	88.00	44
C240	Diesel	2369	4	86.00	16
G180Z	Petrol	1817	4	84.00	30
G200	Petrol	1949	4	87.00	1
G200	Petrol	1949	4	87.00	34
G200	Petrol	1949	4	87.00	4
G200Z	Petrol	1949	4	87.00	11
G200Z	Petrol	1949	4	87.00	42



KW/PS

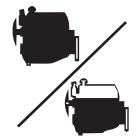

2000 2.0L Piazza					01/84 →	1	BM490 (Graphite)	DM491 ■	GM491 →04/84
G200	1949	4	87.00	SOHC					
2000 2.0L Pick Up Diesel					01/71 →05/98	2	AX180 (Fibre) 01/79 →12/80 BJ650 (Fibre) 01/81 →	CX182 ■ ○ 01/79 →12/80 DJ650 ○ 01/81 →12/82 DJ654 01/82 →12/83 DJ652 01/83 →	FX182 01/79 →12/80 GJ650 ○ 01/81 →12/82 GJ653 01/83 →12/87
C190	1951	4	86.00	SOHC	40/54				
2000 2.0L Van					01/86 →	3	BP980 (Graphite)	DP980	GP980
2000 2.0L Wagon					01/86 →				
4ZC1	1995	4	88.00	SOHC	61-81/ 83-110				
2000 2.0L Wagon Trooper					01/84 →	4	BM490 (Graphite)	DM491 ■	GM491
G200	1949	4	87.00	SOHC					
2300 2.3L Pick Up					11/85 →	5	BP920 (Graphite) (30-028321-00) 01/87 → BR920 (Graphite) 01/88 →	DP920 (21-28321-20/0) 01/87 →	GP921 [130] GP920 [131] 01/87 → GR920 01/88 →
4ZD1	2254	4	89.30	SOHC	66-75/ 90-102				
2600 2.6L Pick Up					01/88 →	6	BR940 (Graphite) (30-028350-00)	DR940	GR940
4ZE1	2559	4	92.60	Injection, SOHC	85/115				
2800 2.8L Van Diesel					01/84 →	7	BR990 (MLS)	DR991 (21-28351-21/0)	GR991
4JB1	2771	4	93.00		50-74/ 68-101				
Aska 2.0L Diesel					01/83 →12/91	8	BK501 (Steel Elastomer), 1.25mm →0.51 →0.61mm BK502 (Steel Elastomer), 1.35mm →0.62 →0.71mm BK503 (Steel Elastomer), 1.45mm →0.72 →0.81mm	DK502 ▲	
4FC1T	1995	4	84.00	Indirect Injection, SOHC, Turbo	51-62/ 69-84				
Aska 2.0L D Diesel					04/83 →06/89	9	BK500 (Steel Elastomer) BN190 (Graphite)		
4FC1	1995	4	84.00	SOHC	49-54/ 66-73				
Bighorn 2.2L Turbo Diesel					→12/88	10	BR200 (Steel)	DR200	
C223T	2238	4	88.00	Indirect Injection, SOHC, Turbo	53/72				
Campo 2.0L					06/85 →12/88	11	BM490 (Graphite)	DM491 ■	GM491
Campo 2.0L 4WD					06/85 →12/88				
G200Z	1949	4	87.00	SOHC	58/79				
Campo 2.2L					01/89 →12/90	12	BP920 (Graphite) (30-028321-00)	DP920 (21-28321-20/0)	GP920
4ZD1	2254	4	89.30	SOHC	66-75/ 90-102				
Campo 2.2L D Diesel					01/83 →12/91	13	BM370 (Fibre) (30-028348-00) BR200 (Steel)	DM370 ○ (21-28348-21/0)	GM370 ○ [131] GM372 ■ [130]
Campo 2.2L D 4WD Diesel					01/83 →12/90				
C223	2238	4	88.00		45/61				
Campo 2.5L D Diesel					01/83 →12/90	14	BR990 (MLS)	DR990	GR990
Campo 2.5L D 4WD Diesel					01/83 →12/90				
4JA1	2499 2499	4 4	93.00		55/75 50-56/ 68-76				

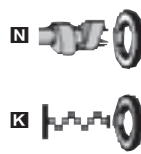
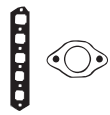

AX180



JN634



BJ650



JN707



BK500



JJ192



BM370



JJ204



BM490



JJ358



BN190



JJ454



BP920

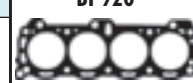

BP980



BR200



BR920



BR940



BR990



HA313



JC060



JC643

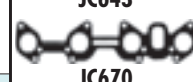

JC670



JC683



JC684



JN191



JN408



JN456



JN456







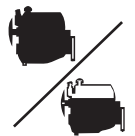



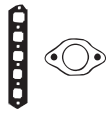

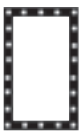

















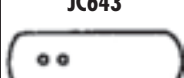



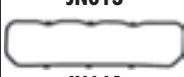



































	JC060 →04/84 HA313 ⊙JE751 →04/84	JN191		PA933 (x8)	NJ014 50x68x9mm, NBR NJ943 82x105x10mm, MVQ				
	JC643 01/79→	JN408 01/82→	JH016 [131] 01/79→12/82 JJ192 [131] 01/84→		NJ060 82x105x13mm, MVQ 01/75→12/79 NJ014 50x68x9mm, NBR 01/82→ NJ265 82x105x13mm, MVQ 01/82→ NJ266 65x84x9mm, NBR 01/83→				
	JC670 JC683	JN634 (50-028320-00) HL532	JJ358	PA933 (x8)	NJ454 30x45x8mm, NBR NJ323 40x56x7mm, NBR NJ322 95x118x10mm, NBR				
	JC060 HA313 ⊙JE751	JN191		PA933 (x8)	NJ014 50x68x9mm, NBR NJ943 82x105x10mm, MVQ				
	JC684 JC683	JN634 (50-028320-00) HL532	JJ358 [130]	PA933 (x8)	NJ454 30x45x8mm, NBR NJ323 40x56x7mm, NBR NJ322 95x118x10mm, NBR				
	JC683	JN634 (50-028320-00) HL532		PA933 (x8)	NJ454 30x45x8mm, NBR NJ323 40x56x7mm, NBR NJ322 95x118x10mm, NBR				
HBS287 (22-20005B) M11x1.50x121mm (x18)	JD470 (31-029753-00)	JN707	JJ454	PA418 (x8)	NJ267 42x55x9mm, NBR NJ014 50x68x9mm, NBR NJ322 95x118x10mm, NBR				
		JN456	JJ204						
HBS286 (22-20006B) M11x1.50x117mm (x3) M11x1.50x116mm (x16)	JC643 ⊙JE751	JN408	JH016	PA418 (x8)	NJ267 42x55x9mm, NBR NJ266 65x84x9mm, NBR NJ265 82x105x13mm, MVQ				
	JC060 (x2) HA313 ⊙JE751	JN191		PA933 (x8)	NJ014 50x68x9mm, NBR NJ943 82x105x10mm, MVQ				
	JC684 JC683	JN634 (50-028320-00) HL532	JJ358	PA933 (x8)	NJ454 30x45x8mm, NBR NJ323 40x56x7mm, NBR NJ322 95x118x10mm, NBR				
HBS286 (22-20006B) M11x1.50x117mm (x3) M11x1.50x116mm (x16)	JC643 ⊙JE019	JN408	JJ192 [130]		NJ267 42x55x9mm, NBR NJ014 50x68x9mm, NBR NJ265 82x105x13mm, MVQ				
		JN707	HC5008	PA418 (x8) 01/88→	NJ267 42x55x9mm, NBR NJ014 50x68x9mm, NBR NJ322 95x118x10mm, NBR				



KWPS



Elf 2.0L Route van Diesel				01/71 → 05/98		15		AX180 (Fibre)		CX182		FX182	
C190	1951	4	86.00	SOHC		40/54		01/79 → 12/80		01/79 → 12/80		01/79 → 12/80	
								BJ650 (Fibre)		DJ650		GJ650	
								01/81 →		01/81 → 12/82		01/81 → 12/82	
										DJ654		GJ653	
										01/82 → 12/83		01/83 → 12/87	
										DJ652			
										01/83 →			
Elf 2.4L (KA42) Diesel				01/82 →		16		BJ650 (Fibre)		DJ654		GJ655	
Elf 2.4L (KA52) Diesel				01/82 →									
C240	2369	4	86.00										
Elf 2.5L (KT26/36TLD26/56/66) Diesel				11/85 →		17		BK040 (Fibre)		DK047		GK044	
Elf 2.5L (TLD46WF) Diesel				11/85 →						11/85 →		GK047	
Elf 2.5L (TLD66QRM) Diesel				11/85 →									
4BC2	3268	4	102.00			65/88							
Elf 2.5L (NHR54/55) Diesel				01/84 →		18		BR990 (MLS)		DR990		GR990	
4JA1	2499	4	93.00			50-56/ 68-76							
Elf 2.5L (NKR) Diesel				11/85 →		19		BK040 (Fibre)		DK047		GK044	
4BC2	3268	4	102.00			65/88						GK047	
Elf 2.8L (WFR55) Diesel				01/84 →		20		BR990 (MLS)		DR991		GR991	
4JB1	2771	4	93.00			50-74/ 68-101				(21-28351-21/0)			
Elf 3.5L (TLD26/56/66/KT26) Diesel				11/85 →		21		BK040 (Fibre)		DK047		GK044	
4BC2	3268	4	102.00			65/88						GK047	
Fargo 2.0L (WF531/53D/53F/532/553) Diesel				01/83 → 12/88		22		BR190 (Graphite)		DR190		GR190	
4FD1	2189	4	88.00			45-54/ 61-73		(30-028342-00)		(21-28342-20/0)		12/86 →	
								12/86 →		12/86 →			
Fargo 2.0L (WFR51) Diesel				01/83 → 12/91		23		BK501 (Steel Elastomer), 1.25mm		DK502▲			
Fargo 2.0L (WFR51DW) Diesel				01/83 → 12/91				☞0.51 → 0.61mm					
Fargo 2.0L (WFS51) Diesel				01/83 → 12/91				BK502 (Steel Elastomer), 1.35mm					
Fargo 2.0L (WFS51DW) Diesel				01/83 → 12/91				☞0.62 → 0.71mm					
4FC1T	1995	4	84.00	Indirect Injection, SOHC, Turbo		51-62/ 69-84		BK503 (Steel Elastomer), 1.45mm					
								☞0.72 → 0.81mm					
Fargo 2.0L Van Diesel				01/85 → 12/88		24		BN190 (Graphite)		DN190		GN190	
4FC1	1995	4	84.00	SOHC		49-54/ 66-73							
Florian 2.0L (PAD30) Diesel				01/71 → 05/98		25		AX180 (Fibre)		CX182		FX182	
Florian 2.0L Van Diesel				01/71 → 05/98				01/79 → 12/80		01/79 → 12/80		01/79 → 12/80	
C190	1951	4	86.00	SOHC		40/54		BJ650 (Fibre)		01/81 → 12/82		01/81 → 12/82	
								01/81 →		01/82 → 12/83		01/83 → 12/87	
										DJ654		GJ653	
										01/83 →			
										DJ652			
Gemini 1.5L (JT150)				03/85 →		26		BN610 (Graphite)		DN610			
4XC1	1471	4	77.00	SOHC		52-56/ 71-76							











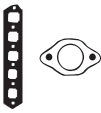

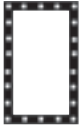

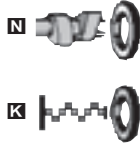







								
	JC643  01/79→	JN408 01/82→	JH016 [131] 01/79→12/82 JJ192 [131] 01/84→			<input checked="" type="checkbox"/> NJ060  82x105x13mm, MVQ 01/75→12/79 <input checked="" type="checkbox"/> NJ014  50x68x9mm, NBR 01/82→ <input checked="" type="checkbox"/> NJ265  82x105x13mm, MVQ 01/82→ <input checked="" type="checkbox"/> NJ266  65x84x9mm, NBR 01/83→		 AX180  BJ650  BK040  BN190  BN610  BR190  BR990  JC284  JC336  JC429  JC643  JN408  JN456  JN504  JN613  JN661  JN707  JJ177
	JC643   JE019	JN408	JH016	PA418 (x8)		<input checked="" type="checkbox"/> NJ014  50x68x9mm, NBR <input checked="" type="checkbox"/> NJ265  82x105x13mm, MVQ		
	JC336 	JN504 JN661	JJ177 JJ376			<input checked="" type="checkbox"/> NJ231  60x82x12mm, MVQ <input checked="" type="checkbox"/> NJ646  100x135x10mm, MVQ		
		JN707	JJ470 01/88→	PA418 (x8) 01/88→		<input checked="" type="checkbox"/> NJ267  42x55x9mm, NBR <input checked="" type="checkbox"/> NJ014  50x68x9mm, NBR <input checked="" type="checkbox"/> NJ322  95x118x10mm, NBR		
	JC336 	JN504 JN661				<input checked="" type="checkbox"/> NJ231  60x82x12mm, MVQ <input checked="" type="checkbox"/> NJ646  100x135x10mm, MVQ		
HBS287  (22-20005B) M11x1.50x121mm (x18)	JD470  (31-029753-00)	JN707	JJ454	PA418 (x8)		<input checked="" type="checkbox"/> NJ267  42x55x9mm, NBR <input checked="" type="checkbox"/> NJ014  50x68x9mm, NBR <input checked="" type="checkbox"/> NJ322  95x118x10mm, NBR		
	JC336 	JN504 JN661				<input checked="" type="checkbox"/> NJ231  60x82x12mm, MVQ <input checked="" type="checkbox"/> NJ646  100x135x10mm, MVQ		
	JC429  12/86→ JC284 	JN456	JJ204	PA933  (x8)		<input checked="" type="checkbox"/> NJ321  28x47x8mm, NBR <input checked="" type="checkbox"/> NJ323  40x56x7mm, NBR <input checked="" type="checkbox"/> NJ322  95x118x10mm, NBR		
		JN456	JJ204					
	JC429  JC284 		JJ204			<input checked="" type="checkbox"/> NJ321  28x47x8mm, NBR <input checked="" type="checkbox"/> NJ323  40x56x7mm, NBR <input checked="" type="checkbox"/> NJ322  95x118x10mm, NBR		
	JC643  01/79→	JN408 01/82→	JH016 [131] 01/79→12/82 JJ192 [131] 01/84→			<input checked="" type="checkbox"/> NJ060  82x105x13mm, MVQ 01/75→12/79 <input checked="" type="checkbox"/> NJ014  50x68x9mm, NBR 01/82→ <input checked="" type="checkbox"/> NJ265  82x105x13mm, MVQ 01/82→ <input checked="" type="checkbox"/> NJ266  65x84x9mm, NBR 01/83→		
	 JE751 01/87→	JN613	JJ345	PA658 (x8) (50-319265-00)		<input checked="" type="checkbox"/> NJ449  40x52x6mm, NBR (50-319266-00) <input checked="" type="checkbox"/> NJ875  32x44x6mm, ACM <input checked="" type="checkbox"/> NJ450  45x68x12mm, NBR <input checked="" type="checkbox"/> NJ449  40x52x6mm, NBR (50-319266-00) <input checked="" type="checkbox"/> NJ446  87x100x8mm, MVQ		



KW/PS



Gemini 1.5L D Diesel					02/88 → 12/90	27	AY840 (MLS), 1.40mm (30-028998-00) →Eng.975024/975025-178581		CY811▲■ (21-27776-22/0)	FY811▲ (20-27776-02/0)
Gemini 1.5L TD Diesel					02/88 → 12/90		AY850 (MLS), 1.45mm, 1 Hole (30-028999-00) →Eng.975024/975025-178581			
4EC1	1488	4	76.00	Indirect Injection		37/50	AY860 (MLS), 1.50mm, 2 Holes (30-029000-00) →Eng.975024/975025-178581			
4EC1T	1488	4	76.00	Indirect Injection		49-54/ 67-73	AY900 (MLS), 1.40mm (30-029007-00) Eng.975024/975025-178582→			
							AY910 (MLS), 1.45mm, 1 Hole (30-029006-00) Eng.975024/975025-178582→			
							AY920 (MLS), 1.50mm, 2 Holes (30-029008-00) Eng.975024/975025-178582→			
Gemini 1.6L GTI 16V					08/88 → 12/90	28				EG6260
4XE1	1588	4	80.00	SOHC		84-99/ 114- 135				
Gemini 1.7L TD Diesel					01/90 → 12/93	29	AB5010 (MLS), 1.40mm (30-029163-00) →Eng.975024/975025-178581		CY811▲■ (21-27776-22/0)	FY811▲ (20-27776-02/0)
	1686	4				65/88	AB5020 (MLS), 1.45mm, 1 Hole (30-029164-00) →Eng.975024/975025-178581			
							AB5030 (MLS), 1.50mm, 2 Holes (30-029165-00) →Eng.975024/975025-178581			
Gemini 1.8L (PF60)					01/81 → 12/82	30	BD360 (Graphite) →09/82		DD363 →09/82	GD363 →09/82
G180Z	1817	4	84.00	SOHC		81/110	BM490 (Graphite) 10/82→		DM491■ 10/82→	GM491 10/82→
Gemini 1.8L (PFD60) Diesel					01/83 → 12/86	31	BK500 (Steel Elastomer)			
4FB1T	1817	4	84.00	Turbo						
I-Mark 1.5L (JTU69M79/RMC)					03/85 →	32	BN610 (Graphite)		DN610	
4XC1	1471	4	77.00	SOHC		52-56/ 71-76				

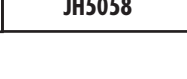









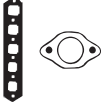

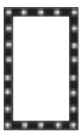

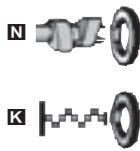











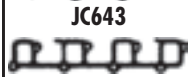

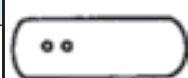





								 AB5010, AB5020, AB5030	 JJ204
HBS036 ® (22-29001B) M12x1.5x102mm (x10)	JD303 ■ JD304 ■	JN776 →12/88 →Eng.00804794 JN777 (50-027776-00) 01/89→ Eng.00804795→	JH5058 (31-027781-00)	PA658 (x8) (50-319265-00)	NJ449 40x52x6mm, NBR (50-319266-00) NJ449 ■ 40x52x6mm, NBR (50-319266-00) NK103 ■ 87x100x8.5mm, FPM			 AY840, AY850, AY860	 JJ345
HBS036 ® (22-29001B) M12x1.5x102mm (x10)	JD303 ■ JD304 ■	JN776 →12/88 →Eng.00804794 JN777 (50-027776-00) 01/89→ Eng.00804795→	JH5058 (31-027781-00)	PA658 (x8) (50-319265-00)	NJ449 40x52x6mm, NBR (50-319266-00) NJ449 ■ 40x52x6mm, NBR (50-319266-00) NK103 ■ 87x100x8.5mm, FPM			 AY900, AY910, AY920	
								 BD360, BM490	
								 BK500	
								 BN610	
								 HA313	
								 JC060	
								 JC284	
								 JC429	
								 JD303	
								 JD304	
	JC060 ■ (x2) 10/82→ HA313 ■ JE751 10/82→			PA933 (x8)	NJ014 ■ 50x68x9mm, NBR NJ060 ■ 82x105x13mm, MVQ →09/82 NJ943 ■ 82x105x10mm, MVQ 10/82→			 JN456	
	JC429 ■ JC284 ■	JN456	JJ204	PA933 (x8)	NJ321 28x47x8mm, NBR NJ323 ■ 40x56x7mm, NBR NJ322 ■ 95x118x10mm, NBR			 JN613	
	JE751 01/87→	JN613	JJ345	PA658 (x8) (50-319265-00)	NJ449 40x52x6mm, NBR (50-319266-00) NJ875 32x44x6mm, ACM NJ450 ■ 45x68x12mm, NBR NJ449 ■ 40x52x6mm, NBR (50-319266-00) NJ446 ■ 87x100x8mm, MVQ			 JN777	
								 JH5058	



KW/PS



I-Mark 1.5L Turbo Diesel				01/85 → 12/90		33	AY840 (MLS), 1.40mm (30-028998-00) →Eng.975024/975025-178581 AY850 (MLS), 1.45mm, 1 Hole (30-028999-00) →Eng.975024/975025-178581 AY860 (MLS), 1.50mm, 2 Holes (30-029000-00) →Eng.975024/975025-178581 AY900 (MLS), 1.40mm (30-029007-00) Eng.975024/975025-178582→ AY910 (MLS), 1.45mm, 1 Hole (30-029006-00) Eng.975024/975025-178582→ AY920 (MLS), 1.50mm, 2 Holes (30-029008-00) Eng.975024/975025-178582→	CY811▲■ (21-27776-22/0)	FY811▲ (20-27776-02/0)
4EC1T	1488	4	76.00	Indirect Injection, Turbo	49-54/ 67-73				
Impulse 2.0L (JR130)				01/84 →		34	BM490 (Graphite)	DM491■ →04/84	GM491 →04/84
G200	1949	4	87.00	SOHC					
KAD51/41 2.0L Pick Up Diesel				01/71 → 05/98		35	AX180 (Fibre) 01/79 → 12/80 BJ650 (Fibre) 01/81 →	CX182■○ 01/79 → 12/80 DJ650○ 01/81 → 12/82 DJ654 01/82 → 12/83 DJ652 01/83 →	FX182 01/79 → 12/80 GJ650○ 01/81 → 12/82 GJ653 01/83 → 12/87
C190	1951	4	86.00	SOHC	40/54				
KDB36 2.2L Turbo Diesel				→ 12/88		36	BR200 (Steel)	DR200	
C223T	2238	4	88.00	Indirect Injection, SOHC, Turbo	53/72				
Midi 2.0L TD Diesel				01/89 →		37	BK501 (Steel Elastomer), 1.25mm ☞0.51 → 0.61mm BK502 (Steel Elastomer), 1.35mm ☞0.62 → 0.71mm BK503 (Steel Elastomer), 1.45mm ☞0.72 → 0.81mm	DK502▲	
4FC1T	1995	4	84.00	Indirect Injection, SOHC	51-62/ 69-84				
Midi 2.2L D Diesel				01/89 →		38	BR190 (Graphite) (30-028342-00)	DR190 (21-28342-20/0)	GR190
Midi 2.2L D 4WD Diesel				01/89 →					
Midi Van 2.2L D 4WD Diesel				09/88 →					
4FD1	2189	4	88.00		45-54/ 61-73				
Midi 2.4L D Diesel				01/94 →		39	BR190 (Graphite) (30-028342-00)	DR190 (21-28342-20/0)	
Midi 2.4L TD Diesel				01/94 →					
Midi Van 2.4L TD Diesel				02/94 →					
4FG1T	2380	4	89.30	Indirect Injection	56/76				

								
HBS036 ® [22-29001B] M12x1.5x102mm (x10)	JD303 ■ JD304 ■	JN776 →12/88 →Eng.00804794 JN777 [50-027776-00] 01/89→ Eng.00804795→	JH5058 [31-027781-00]	PA658 (x8) [50-319265-00]	NJ449 40x52x6mm, NBR [50-319266-00] NJ450 45x68x12mm, NBR NJ449 40x52x6mm, NBR [50-319266-00]			 AX180  AY840, AY850, AY860  AY900, AY910, AY920  BJ650  BM490  BR190  BR200  HA313  JC060  JC284  JC429  JC643  JD303  JD304  JN191  JN408  JN456
	JC060 ■ →04/84 HA313 ■  JE751 →04/84	JN191		PA933 (x8)	 NJ014 50x68x9mm, NBR  NJ943 82x105x10mm, MVQ			
	JC643 ■ 01/79→	JN408 01/82→	JH016 [131] 01/79→12/82 JJ192 [131] 01/84→		 NJ060 82x105x13mm, MVQ 01/75→12/79  NJ014 50x68x9mm, NBR 01/82→  NJ265 82x105x13mm, MVQ 01/82→  NJ266 65x84x9mm, NBR 01/83→			
HBS286 ® [22-20006B] M11x1.50x117mm (x3) M11x1.50x116mm (x16)	JC643 ■  JE751	JN408	JH016	PA418 (x8)	 NJ267 42x55x9mm, NBR  NJ266 65x84x9mm, NBR  NJ265 82x105x13mm, MVQ			
		JN456	JJ204					
HBS265 ® [22-33027B] M12x1.50x155mm (x16)	JC429 ■ JC284 ■	JN456	JJ204	PA933 (x8)	 NJ321 28x47x8mm, NBR  NJ323 40x56x7mm, NBR  NJ322 95x118x10mm, NBR			



KW/PS



N 1.5L Turbo Diesel		01/85 → 12/90		40		AY840 (MLS), 1.40mm (30-028998-00) → Eng. 975024/975025-178581 AY850 (MLS), 1.45mm, 1 Hole (30-028999-00) → Eng. 975024/975025-178581 AY860 (MLS), 1.50mm, 2 Holes (30-029000-00) → Eng. 975024/975025-178581 AY900 (MLS), 1.40mm (30-029007-00) Eng. 975024/975025-178582 → AY910 (MLS), 1.45mm, 1 Hole (30-029006-00) Eng. 975024/975025-178582 → AY920 (MLS), 1.50mm, 2 Holes (30-029008-00) Eng. 975024/975025-178582 →		CY811 ▲ ■ (21-27776-22/0)		FY811 ▲ (20-27776-02/0)	
4EC1T	1488	4	76.00	Indirect Injection, Turbo	49-54/ 67-73						
Trooper 2.0L Diesel		→ 12/88		41		BR200 (Steel)		DR200			
C223T	2238	4	88.00	Indirect Injection, SOHC, Turbo	53/72						
Trooper 2.2L		01/83 → 12/85		42		BM490 (Graphite)		DM491 ■			
G200Z	1949	4	87.00	SOHC	58/79						
Trooper 2.2L D Diesel		01/83 → 12/89		43		BM370 (Fibre) (30-028348-00)		DM370 ○ (21-28348-21/0)		GM370 ○ [131] GM372 ■ [130]	
C223	2238	4	88.00	Indirect Injection, SOHC	45/61						
C223T	2238	4	88.00		53/72						
Trooper 2.2L TD Diesel		03/84 → 12/91		44		BR200 (Steel)		DR200			
C223T	2238	4	88.00	Indirect Injection, SOHC	53/72						
Trooper 2.3L		11/85 → 12/91		45		BP920 (Graphite) (30-028321-00)		DP920 (21-28321-20/0)		GP920	
4ZD1	2254	4	89.30	SOHC	66-75/ 90-102						
Trooper 2.6L		01/88 →		46		BR940 (Graphite) (30-028350-00)		DR940		GR940	
4ZE1	2559	4	92.60	Injection, SOHC	85/115						
Trooper 2.8L TD Diesel		10/87 → 12/91		47		BR990 (MLS)		CD5400 ▲		ER993 GR991	
4JB1T	2772	4	93.00		64-74/ 87-101						
Trooper 2.8L TD Diesel		10/88 → 12/91		48							
4JB1TC	2752	4	93.00	Indirect Injection	78/106						
Trooper 3.0L DTI Diesel		04/00 →		49				CG5090 ▲			
4 JX1	2999	4	95.40	DOHC, V4	117- 118/ 159- 160						
4JX1T	2999	4	95.40		118/160						
Trooper 3.1L Diesel		08/91 → 07/98		50		AG7720 (Steel), 1.6mm, 1 Notch 4JG2TC AG7730 (Steel), 1.65mm, 2 Notches 4JG2TC AD5400 (Fibre), 1.7mm, 3 Holes		CD5400 ▲		ER993	
4 JG2 T	3059	4	95.40		80-85/ 109- 116						
Trooper 3.2L		08/91 → 07/98		51		AG5080 (Fibre), 1.2mm		CG5500		EG6240	
6VD1	3165	6	93.40	DOHC, V6	130/177						
Trooper 3.5L V6 24V		04/00 →		52		AB5780 (MLS) ■ (x2) 6VE1 AB5781 (MLS) ■		CG5781		EG6240	
6 VE1	3494	6	93.40	CIH	158/215						

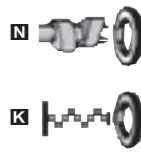
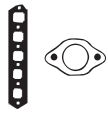

HBS036⊗
(22-29001B)
M12x1.5x102mm (x10)

JD303■
JD304■

JN776
→12/88
→Eng.00804794
JN777
(50-027776-00)
01/89→
Eng.00804795→

JH5058
(31-027781-00)

PA658 (x8)
(50-319265-00)

■ **NJ449** 40x52x6mm, NBR
(50-319266-00)
■ **NJ450** 45x68x12mm, NBR
■ **NJ449** 40x52x6mm, NBR
(50-319266-00)



**AY840, AY850,
AY860**



**AY900, AY910,
AY920**



BM370



BM490



BP920



BR200



BR490



BR940



BR990



JC643



JC683



JC684



JD303



JD304



JN408



JN634



JN707



JN777

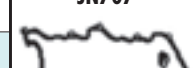

JH5058



JJ192



JJ454

HBS286⊗
(22-20006B)
M11x1.50x117mm (x3)
M11x1.50x116mm (x16)

JC643■
⊗**JE751**

JN408

JH016

PA418 (x8)

■ **NJ267** 42x55x9mm, NBR
■ **NJ266** 65x84x9mm, NBR
■ **NJ265** 82x105x13mm, MVQ

HBS286⊗
(22-20006B)
M11x1.50x117mm (x3)
M11x1.50x116mm (x16)

JC643■
⊗**JE019**

JN408

JJ192 (x2) [130]

■ **NJ267** 42x55x9mm, NBR
■ **NJ014** 50x68x9mm, NBR
■ **NJ265** 82x105x13mm, MVQ

HBS286⊗
(22-20006B)
M11x1.50x117mm (x3)
M11x1.50x116mm (x16)

JC643■
⊗**JE751**

JN408

JH016

PA418 (x8)

■ **NJ267** 42x55x9mm, NBR
■ **NJ266** 65x84x9mm, NBR
■ **NJ265** 82x105x13mm, MVQ

JC684■
JC683■

JN634
(50-028320-00)
HL532■

PA933 (x8)

■ **NJ454** 30x45x8mm, NBR
■ **NJ323** 40x56x7mm, NBR
■ **NJ322** 95x118x10mm, NBR

JC683■

JN634
(50-028320-00)
HL532■

PA933 (x8)

■ **NJ454** 30x45x8mm, NBR
■ **NJ323** 40x56x7mm, NBR
■ **NJ322** 95x118x10mm, NBR

HBS287⊗
(22-20005B)
M11x1.50x121mm (x18)

JD470■
(31-029753-00)

JN707

HC5008■
JJ454

PA418 (x8)

■ **NJ267** 42x55x9mm, NBR
■ **NJ014** 50x68x9mm, NBR
■ **NJ322** 95x118x10mm, NBR

HBS287⊗
(22-20005B)
M11x1.50x121mm (x18)

JN408

JN634

JN707

JN777

JH5058

JJ192

JJ454

JM5078 (x2)

ISUZU



KW/PS

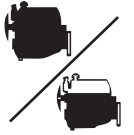

Wfr 1.8L Van

01/83 → 12/90

53

BM330 (Graphite)

DM330 ■

4ZB1

1818











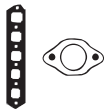

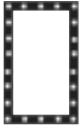

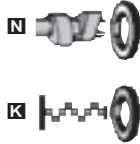
4

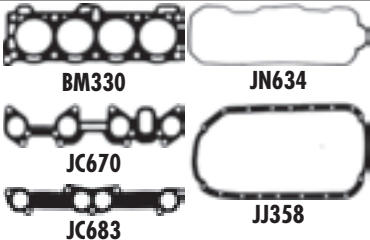







84.00

SOHC

56-77/
76-105

(30-028358-00)

							
	JC670  JC683 	JN634 <i>(50-028320-00)</i> HL532 	JJ358	PA933  (x8)	NJ454 30x45x8mm, NBR  NJ323 40x56x7mm, NBR  NJ322 95x118x10mm, NBR 		







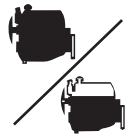



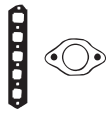

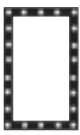

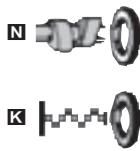

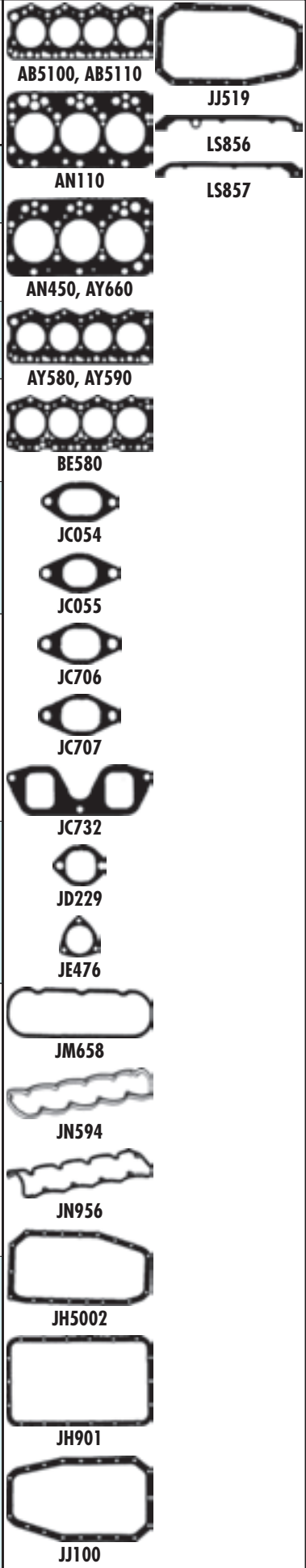





































































		CC			9			CC			9
803 A.062 (8030.01)	Diesel	2339	3	95.00	1	8140.61.200	Diesel	2445	4	93.00	23
803 A.062 (8030.01)	Diesel	2339	3	95.00	2	8140.61.300	Diesel	2445	4	93.00	37
803 A.062 (8030.01)	Diesel	2339	3	95.00	3	8140.61.300	Diesel	2445	4	93.00	39
8030.02	Diesel	2592	3	100.00	4	8140.61.300	Diesel	2445	4	93.00	5
8140.07.2585	Diesel	2499	4	93.00	9	8140.61.300	Diesel	2445	4	93.00	7
8140.07.2700	Diesel	2499	4	93.00	24	8140.63.3700	Diesel	2798	4	94.40	16
8140.07.2710	Diesel	2499	4	93.00	8	8140.63.4000	Diesel	2798	4	94.40	13
8140.07.3710	Diesel	2499	4	93.00	9	8140.63.4000	Diesel	2798	4	94.40	18
8140.07.3711	Diesel	2499	4	93.00	9	8140.67 (290B7W)	Diesel	2500	4	93.00	10
8140.07.3712	Diesel	2499	4	93.00	9	8140.67 (290B7W)	Diesel	2500	4	93.00	40
8140.07.3713	Diesel	2499	4	93.00	9	8140.67.2585	Diesel	2500	4	93.00	11
8140.21	Diesel	2445	4	93.00	38	8140.67F.	Diesel	2449	4	93.00	20
8140.21	Diesel	2445	4	93.00	44	8140.67F.	Diesel	2449	4	93.00	24
8140.21	Diesel	2445	4	93.00	6	8140.67F.3700	Diesel	2500	4	93.00	11
8140.21.200	Diesel	2499	4	93.00	25	8140.67F.3710	Diesel	2500	4	93.00	11
8140.21.200	Diesel	2499	4	93.00	27	8140.67F.3711	Diesel	2500	4	93.00	11
8140.21.212	Diesel	2445	4	93.00	45	8144.67	Diesel	2500	4	93.00	10
8140.21.290	Diesel	2445	4	93.00	45	8144.67	Diesel	2500	4	93.00	40
8140.23.	Diesel	2798	4	94.40	29	8144.67F	Diesel	2500	4	93.00	11
8140.23.	Diesel	2798	4	94.40	30	8149.03.3971	Diesel	2798	4	94.40	41
8140.23.2585	Diesel	2799	4	94.40	14	F1AE 0481 A	Diesel	2287	4	88.00	32
8140.23.2585	Diesel	2799	4	94.40	48	F1CE 0481 FA	Diesel	2998	4	95.80	36
8140.23.3700	Diesel	2799	4	94.40	14	F1CE 0481 HA	Diesel	2998	4	95.80	36
8140.23.3700	Diesel	2799	4	94.40	48	F1CE 0481 HC	Diesel	2998	4	95.80	36
8140.23.3800	Diesel	2798	4	94.40	15						
8140.27 S	Diesel	2445	4	93.00	21						
8140.27 S	Diesel	2445	4	93.00	25						
8140.27.210	Diesel	2445	4	93.00	43						
8140.27.213	Diesel	2445	4	93.00	43						
8140.27.218	Diesel	2445	4	93.00	43						
8140.27.2700	Diesel	2499	4	93.00	26						
8140.27.2700	Diesel	2499	4	93.00	28						
8140.27.2720	Diesel	2499	4	93.00	26						
8140.27R.2700	Diesel	2499	4	93.00	12						
8140.27R.2700	Diesel	2499	4	93.00	46						
8140.27S.2700	Diesel	2499	4	93.00	12						
8140.27S.2700	Diesel	2499	4	93.00	46						
8140.27S.2801	Diesel	2499	4	93.00	47						
8140.27S.2811	Diesel	2499	4	93.00	47						
8140.27S.2885	Diesel	2499	4	93.00	47						
8140.27S.3811	Diesel	2499	4	93.00	47						
8140.43.	Diesel	2798	4	94.40	31						
8140.43.2585	Diesel	2799	4	94.40	14						
8140.43.2585	Diesel	2799	4	94.40	48						
8140.43.3700	Diesel	2799	4	94.40	14						
8140.43.3700	Diesel	2799	4	94.40	48						
8140.43.3900 (S9WA7)	Diesel	2799	4	94.40	14						
8140.43.3900 (S9WA7)	Diesel	2799	4	94.40	48						
8140.43B	Diesel	2798	4	94.40	33						
8140.43C	Diesel	2798	4	94.40	33						
8140.43C.4000	Diesel	2800	4	94.40	17						
8140.43M.4300	Diesel	2800	4	94.40	19						
8140.43M.4300	Diesel	2800	4	94.40	42						
8140.43M.4320	Diesel	2800	4	94.40	19						
8140.43M.4320	Diesel	2800	4	94.40	42						
8140.43M.4330	Diesel	2800	4	94.40	19						
8140.43M.4330	Diesel	2800	4	94.40	42						
8140.43S	Diesel	2798	4	94.40	34						
8140.43S	Diesel	2798	4	94.40	35						
8140.43S	Diesel	2800	4	94.40	19						
8140.43S	Diesel	2800	4	94.40	42						
8140.47 R	Diesel	2499	4	93.00	25						
8140.47 R	Diesel	2499	4	93.00	26						
8140.47.2700	Diesel	2499	4	93.00	26						
8140.47.2711	Diesel	2499	4	93.00	26						
8140.47.2721	Diesel	2499	4	93.00	26						
8140.47R.2790	Diesel	2499	4	93.00	26						
8140.47R.2790	Diesel	2499	4	93.00	28						
8140.61.200	Diesel	2445	4	93.00	22						



KW/PS



570 2.3L Turbo D Diesel						1	AN110 (Fibre) (30-029262-00)	CN458○	
803 A.062 (8030.01)	2339	3	95.00						
612 NE 2.3L D Diesel						2	AN110 (Fibre) (30-029262-00)	CN458○	
803 A.062 (8030.01)	2339	3	95.00		01/66 → 12/71				
616 N2 2.3L D Diesel						3	AN110 (Fibre) (30-029262-00)	CN458○	
803 A.062 (8030.01)	2339	3	95.00		01/68 → 12/71				
616 N3 2.6L D Diesel						4	AN450 (Fibre), 1.35mm (30-027706-00) AY660 (Fibre), 1.58mm (30-028340-00)	CN458○	
8030.02	2592	3	100.00		01/70 →				
Combi 32.8 Diesel						5	BE580 (Fibre), 1.35mm (30-024116-10)	DE588▲ [109] (21-26037-23/0)	FY291 ▲ [12] (20-27426-00/0)
Combi 35.8 Diesel									
Combi 40.8 Diesel									
8140.61.300	2445	4	93.00		01/79 → 12/89				
Daily 2.4L TD Diesel						6	AB5100 (Fibre), 1.20mm [112] (30-027140-10) AY580 (Fibre), 1.30mm [112] (30-027141-10) AY590 (Fibre), 1.40mm [112] (30-027892-10) AB5110 (Fibre), 1.50mm (30-027147-10)	DS381▲ [111] (21-27141-20/0)	FB5100 ▲ [12] (20-27140-00/0)
Daily 35.10 Diesel									
Daily 40.10 Diesel									
Daily 45.10 Diesel									
Daily 49.10 Diesel									
8140.21	2445	4	93.00	Turbo	01/85 → 12/89				
Daily 28.8 Diesel						7	BE580 (Fibre), 1.35mm (30-024116-10)	DE588▲ [109] (21-26037-23/0)	FY291 ▲ [12] (20-27426-00/0)
Daily 30.8 Diesel									
Daily 32.8 Diesel									
Daily 35.8 Diesel									
Daily 40.8 Diesel									
8140.61.300	2445	4	93.00		01/79 → 12/89				
Daily 2.5L D Diesel						8	AB5100 (Fibre), 1.20mm [112] (30-027140-10) AY580 (Fibre), 1.30mm [112] (30-027141-10) AY590 (Fibre), 1.40mm [112] (30-027892-10) AB5110 (Fibre), 1.50mm (30-027147-10)	DE588▲ [109] (21-26037-23/0) → 12/94	FB5101 ▲ [167] (20-27140-01/0)
8140.07.2710	2499	4	93.00	Direct injection, Turbo	01/89 →	55/75			
Daily 2.5L TD Diesel						9	AB5100 (Fibre), 1.20mm [112] (30-027140-10) AY580 (Fibre), 1.30mm [112] (30-027141-10) AY590 (Fibre), 1.40mm [112] (30-027892-10) AB5110 (Fibre), 1.50mm (30-027147-10)	DE588▲ [109] (21-26037-23/0)	FB5100 ▲ [12] (20-27140-00/0)
Daily 30.8 Diesel									
Daily 35.8 Diesel									
Daily 35.8H Diesel									
Daily 40.8 Diesel									
Daily 40.8H Diesel									
8140.07.2585	2499	4	93.00	Sofim, Euro 1	01/85 → 12/89				
8140.07.3710	2499	4	93.00	Direct Injection, Turbo Intercooled	01/89 →				
8140.07.3711/ 8140.07.3712/ 8140.07.3713	2499	4	93.00	Sofim	01/89 →				











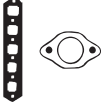

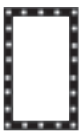

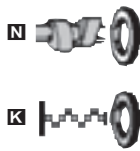

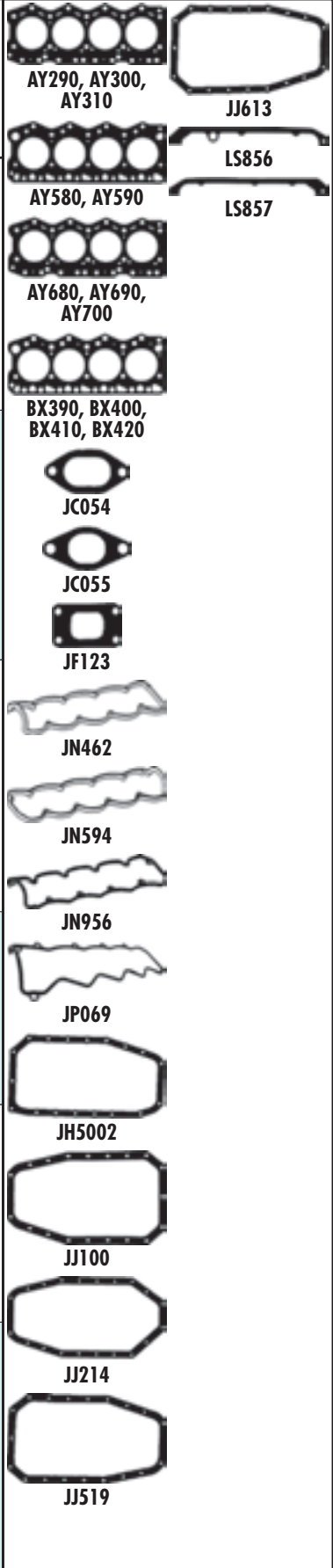















































								
	JC732  JD229   JE476	JM658				KA499 [13] LR948 [13] KT465 [54]	AB5100, AB5110 AN110 AN450, AY660 AY580, AY590 BE580 JC054 JC055 JC706 JC707 JC732 JD229 JE476 JM658 JN594 JN956 JH5002 JH901 JJ100 JR580 [11] LC281 [11] LC282 [11] LS858 [11] LS859 [11] KV927 [46]	
	JC732  JD229   JE476	JM658				KA499 [13] LR948 [13] KT465 [54]	JJ519 LS856 LS857	
	JC732  JD229   JE476	JM658				KA499 [13] LR948 [13] KT465 [54]		
	JC732  JD229   JE476	JM658	JH901			KD929 [72][73]		
HBS011  [22-51004B] M12x1.25x160mm (x10) M12x1.25x119mm (x12)	JC054  (31-024274-10) JC055  (31-025031-10)	JN594 [71] (50-026037-00)	JJ100 LS856 (50-025627-00) LS857 (50-025628-00)	HR602  24-30670-61/0 HR782 	 NP067 50x70x10mm, FPM (50-307111-70)  NP068 55x70x8mm, FPM (50-303186-00)	KA292 [13] KA546 [13] KA547 [13] HJ271 [39]  JR580 [11]		
HBS011  [22-51004B] M12x1.25x160mm (x10) M12x1.25x119mm (x12)	JC054  (31-024274-10) JC706  JC707  (31-026039-00)	JN594 [71] (50-026037-00)	JJ100 LS856 (50-025627-00) LS857 (50-025628-00)	HR602  24-30670-61/0	 NP067  50x70x10mm, FPM (50-307111-70)  NP068  55x70x8mm, FPM (50-303186-00)  NA5055  70x90x10mm, FPM  NF853  100x118x10mm, FPM (50-307096-70)	HJ271 [39]  JR580 [11] LS858 [11] LS859 [11]		
HBS011  [22-51004B] M12x1.25x160mm (x10) M12x1.25x119mm (x12)	JC054  (31-024274-10) JC055  (31-025031-10)	JN594 [71] (50-026037-00)	JJ100 LS856 (50-025627-00) LS857 (50-025628-00)	HR602  24-30670-61/0 HR782 	 NP067  50x70x10mm, FPM (50-307111-70)  NP068  55x70x8mm, FPM (50-303186-00)  NA5055  70x90x10mm, FPM	KA292 [13] KA546 [13] KA547 [13] HJ271 [39]  JR580 [11]		
HBS011  [22-51004B] M12x1.25x160mm (x10) M12x1.25x119mm (x12)	JC054  (31-024274-10) JC055  (31-025031-10)	JN594 [71] (50-026037-00) JN956	JH5002 JJ519 (31-025623-00) LS856 (50-025627-00) LS857 (50-025628-00)	HR602  24-30670-61/0	 NP067  50x70x10mm, FPM (50-307111-70)  NP068  55x70x8mm, FPM (50-303186-00)  NF885  [3] 70x159x16mm, FPM (50-307266-70)  NA5055  70x90x10mm, FPM  NF883  [3] 114x171x13mm, FPM (50-307265-70)  NF886  [3] 100x120x16mm, FPM (50-307086-70)	JR580 [11] LC281 [11] LC282 [11] LS858 [11] LS859 [11] KV927 [46]		
HBS011  [22-51004B] M12x1.25x160mm (x10) M12x1.25x119mm (x12)	JC054  (31-024274-10) JC055  (31-025031-10)	JN594 [71] (50-026037-00) JN956	JH5002 JJ519 (31-025623-00) LS856 (50-025627-00) LS857 (50-025628-00)	HR602  24-30670-61/0 HR781 	 NP067  50x70x10mm, FPM (50-307111-70)  NP068  55x70x8mm, FPM (50-303186-00)  NF885  [3] 70x159x16mm, FPM (50-307266-70)  NA5055  70x90x10mm, FPM  NF883  [3] 114x171x13mm, FPM (50-307265-70)  NF886  [3] 100x120x16mm, FPM (50-307086-70)	JR580 [11] LC281 [11] LC282 [11] LS858 [11] LS859 [11] KV927 [46]		



KW/PS



Daily 28.8 Diesel		01/89 → 12/94		10		AY290 (Fibre), 1.60mm [112] (30-027426-00)	DE588▲ [109] (21-26037-23/0)	FY291▲ [12] (20-27426-00/0)
Daily 30.8 Diesel		01/89 → 12/94						
Daily 32.8 Diesel		01/89 → 12/94				AY300 (Fibre), 1.70mm [112] (30-026654-20)		
Daily 35.8 Diesel		01/89 → 12/94						
Daily 40.8 Diesel		01/89 → 12/94				AY310 (Fibre), 1.80mm [112] (30-026655-20)		
8140.67 (290B7W)/8144.67	2500	4	93.00	Indirect Injection, Turbo				
Daily 30.8 Diesel		06/96 →		11		AY290 (Fibre), 1.60mm [112] (30-027426-00)	DE588▲ [109] (21-26037-23/0)	FY291▲ [12] (20-27426-00/0)
Daily 35.8 Diesel		06/96 →						
8140.67.2585	2500	4	93.00	SOHC, Euro 2	63/85	AY300 (Fibre), 1.70mm [112] (30-026654-20)		
8140.67F.3700	2500	4	93.00	Indirect Injection, SOHC, Euro 2	63/85	AY310 (Fibre), 1.80mm [112] (30-026655-20)		
8140.67F.3710/ 8140.67F.3711/ 8144.67F	2500	4	93.00	Sofim, SOHC	63/85			
Daily 35.10 Diesel		01/91 →		12		AY580 (Fibre), 1.30mm [112] (30-027141-10)	DS381▲ [111] (21-27141-20/0)	FB5100▲ [12] (20-27140-00/0)
Daily 40.10 Diesel		01/91 →						
Daily 40.10 4x4 Diesel		01/91 →				AY590 (Fibre), 1.40mm [112] (30-027892-10)		
Daily 45.10 Diesel		01/91 →						
Daily 49.10 Diesel		01/91 →						
8140.27R.2700	2499	4	93.00	Turbo	70-67/ 95-92			
8140.27S.2700	2499	4	93.00	Sofim, Turbo	70-67/ 95-92			
Daily 2.8L D Diesel		07/99 →		13		AY680 (Fibre), 1.60mm (30-028607-00)	CY680▲ (21-28607-20/0)	FY690▲ (20-28607-00/0)
8140.63.4000	2798	4	94.40	Sofim, Turbo Intercooled	63/85	AY690 (Fibre), 1.70mm (30-028608-00)		
						AY700 (Fibre), 1.80mm (30-028609-00)		
Daily 2.8L TD Diesel		05/96 →		14		BX390 (Fibre), 1.20mm [71] (30-027867-00)	DX391▲ (21-27867-21/0)	GX410▲ (20-27867-03/0)
8140.23.2585/ 8140.23.3700	2799	4	94.40	Sofim, Direct Injection, Turbo Intercooled	84/114	BX400 (Fibre), 1.30mm [71] (30-027868-00)		
8140.43.2585	2799	4	94.40	Sofim, Direct Injection, Turbo Intercooled, Euro 2	84/114	BX410 (Fibre), 1.40mm [71] (30-027883-00)		
8140.43.3700/ 8140.43.3900 (S9WA7)	2799	4	94.40	Sofim, Direct Injection, Turbo Intercooled	84/114	BX420 (Fibre), 1.50mm [71] (30-027884-00)		
Daily 30.10 Diesel		05/96 →		15		BX390 (Fibre), 1.20mm [71] (30-027867-00)	DX390▲■ (21-27867-20/0)	GX391▲ (20-27867-01/0)
Daily 40.10 4x4 Diesel		05/96 →						
8140.23.3800	2798	4	94.40	Turbo		BX400 (Fibre), 1.30mm [71] (30-027868-00)		
						BX410 (Fibre), 1.40mm [71] (30-027883-00)		
						BX420 (Fibre), 1.50mm [71] (30-027884-00)		











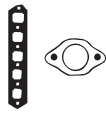

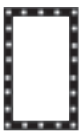

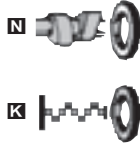

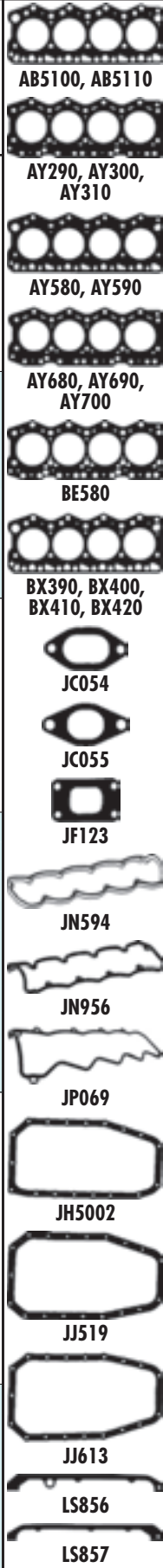











































								
HBS011  (22-51004B) M12x1.25x160mm (x10) M12x1.25x119mm (x12)	JC054  (31-024274-10) JC055  (31-025031-10)	JN462 (50-024272-00) JN594 [71] (50-026037-00) JN956	JJ100 JJ519 (31-025623-00)	HR602  24-30670-61/0	NP067  50x70x10mm, FPM (50-307111-70) NP068  55x70x8mm, FPM (50-303186-00) NF885  [3] 70x159x16mm, FPM (50-307266-70) NA5055  70x90x10mm, FPM NF883  [3] 114x171x13mm, FPM (50-307265-70)	HJ271 [39]  JR580 [11] LC280 [11] LC281 [11] LC282 [11] KV927 [46]	AY290, AY300, AY310 JJ613 AY580, AY590 LS856 AY680, AY690, AY700 LS857	
HBS011  (22-51004B) M12x1.25x160mm (x10) M12x1.25x119mm (x12)	JC054  (31-024274-10) JC055  (31-025031-10)	JN462 (50-024272-00) JN594 [71] (50-026037-00)	JJ100 JJ519 (31-025623-00) LS856 (50-025627-00) LS857 (50-025628-00)	HR602  24-30670-61/0	NP067  50x70x10mm, FPM (50-307111-70) NP068  55x70x8mm, FPM (50-303186-00) NF885  [3] 70x159x16mm, FPM (50-307266-70) NA5055  70x90x10mm, FPM NF883  [3] 114x171x13mm, FPM (50-307265-70)	HJ271 [39]  JR580 [11]	BX390, BX400, BX410, BX420 JC054 JC055 JF123	
HBS011  (22-51004B) M12x1.25x160mm (x10) M12x1.25x119mm (x12)	JC054  (31-024274-10) JC055  (31-025031-10) JF123  (31-027523-00)	JN594 [71] (50-026037-00) JN956	JJ519 (31-025623-00) LS856 (50-025627-00) LS857 (50-025628-00)	HR602  24-30670-61/0 HR781 	NP067  50x70x10mm, FPM (50-307111-70) NP068  55x70x8mm, FPM (50-303186-00) NA5055  70x90x10mm, FPM NF883  [3] 114x171x13mm, FPM (50-307265-70) NF886  [3] 100x120x16mm, FPM (50-307086-70)	KD929 [72][73] JR580 [11]	JN462 JN594 JN956	
HBS255  (22-17021B) M12x1.25x90mm (x8) M12x1.25x160mm (x14)	JC054  (31-024274-10) JC055  (31-025031-10)	JP069	JJ613	HR602  24-30670-61/0	NP067  50x70x10mm, FPM (50-307111-70) NP068  55x70x8mm, FPM (50-303186-00) NA5055  70x90x10mm, FPM NF883  [3] 114x171x13mm, FPM (50-307265-70)	JR580 [11] LC280 [11] LC281 [11] LC282 [11] LS858 [11] LS859 [11] KV927 [46]	JP069	
HBS255  (22-17021B) M12x1.25x90mm (x8) M12x1.25x160mm (x14)	JC054  (31-024274-10) JC055  (31-025031-10)	JN956	JH5002 JJ519 (31-025623-00)	HR602  24-30670-61/0	NP067  50x70x10mm, FPM (50-307111-70) NP068  55x70x8mm, FPM (50-303186-00) NF883  [3] 114x171x13mm, FPM (50-307265-70) NF886  [3] 100x120x16mm, FPM (50-307086-70)	HJ271 [39]  JR580 [11]	JH5002	
HBS255  (22-17021B) M12x1.25x90mm (x8) M12x1.25x160mm (x14)	JC054  (31-024274-10) JC055  (31-025031-10)	JN594 [71] (50-026037-00)	JJ214	HR602  24-30670-61/0	NP067  50x70x10mm, FPM (50-307111-70) NP068  55x70x8mm, FPM (50-303186-00) NF885  [3] 70x159x16mm, FPM (50-307266-70) NA5055  70x90x10mm, FPM NF883  [3] 114x171x13mm, FPM (50-307265-70)	KH007 [70] KD929 [72][73] KD931 [72][73] KD932 [72][73] JR580 [11] LC280 [11] LC281 [11] LC282 [11] KV927 [46]	JJ100 JJ214 JJ519	



KW/PS



Daily 35.8 Diesel		01/98 →		16		AY680 (Fibre), 1.60mm (30-028607-00)	CY680▲ (21-28607-20/0)	FY691▲ [147] (20-28607-01/0)
Daily EuroCargo Diesel		01/98 →				AY690 (Fibre), 1.70mm (30-028608-00)		
8140.63.3700	2798	4	94.40	Sofim, Direct Injection	64/87	AY700 (Fibre), 1.80mm (30-028609-00)		
Daily 35C11 Unijet Diesel		07/99 →		17		BX390 (Fibre), 1.20mm [71] (30-027867-00)	DX391▲ (21-27867-21/0)	GX390▲ (20-27867-00/0)
Daily 35S11 Unijet Diesel		07/99 →				BX400 (Fibre), 1.30mm [71] (30-027868-00)		
Daily 49.12 Diesel		09/90 →12/95				BX410 (Fibre), 1.40mm [71] (30-027883-00)		
Daily 50C11 Unijet Diesel		07/99 →				BX420 (Fibre), 1.50mm [71] (30-027884-00)		
Daily 59.12 Turbo Diesel		04/91 →12/95						
8140.43C.4000	2800	4	94.40	Sofim, Direct injection, Turbo	78/106			
Daily 35C9 Diesel		07/99 →		18		AY680 (Fibre), 1.60mm (30-028607-00)	CY680▲ (21-28607-20/0)	FY690▲ (20-28607-00/0)
8140.63.4000	2798	4	94.40	Sofim, Turbo Intercooled	63/85	AY690 (Fibre), 1.70mm (30-028608-00)		
						AY700 (Fibre), 1.80mm (30-028609-00)		
Daily 35S15 Unijet Diesel		11/01 →		19		BX390 (Fibre), 1.20mm [71] (30-027867-00)	DX400▲ (21-27867-23/0)	GX390▲ (20-27867-00/0)
Daily 50C15 Unijet Diesel		11/01 →				BX400 (Fibre), 1.30mm [71] (30-027868-00)		
Daily 60C15 Unijet Diesel		11/01 →				BX410 (Fibre), 1.40mm [71] (30-027883-00)		
Daily 65C13 Unijet Diesel		11/01 →				BX420 (Fibre), 1.50mm [71] (30-027884-00)		
Daily 65C15 Unijet Diesel		11/01 →						
8140.43M.4300/ 8140.43M.4320/ 8140.43M.4330	2800	4	94.40	Common Rail, Turbo Intercooled	107/146			
8140.43S	2800	4	94.40	Direct Injection, SOHC, Turbo Intercooled, Euro 3 (D3)	107/146			
Daily I 30.8 Diesel		01/96 →08/98		20		BE580 (Fibre), 1.35mm (30-024116-10)	DE588▲ [109] (21-26037-23/0)	FY291▲ [12] (20-27426-00/0) 8140.67F
8140.67F.	2449	4	93.00		60/81	AY290 (Fibre), 1.60mm [112] (30-027426-00)		
						8140.67F		
						AY300 (Fibre), 1.70mm [112] (30-026654-20)		
						8140.67F		
						AY310 (Fibre), 1.80mm [112] (30-026655-20)		
						8140.67F		
Daily I 40.10 V Diesel		01/85 →12/89		21		AB5100 (Fibre), 1.20mm [112] (30-027140-10)	DS381▲ [111] (21-27141-20/0)	FB5100▲ [12] (20-27140-00/0)
8140.27 S	2445	4	93.00		68/92	AY580 (Fibre), 1.30mm [112] (30-027141-10)		
						AY590 (Fibre), 1.40mm [112] (30-027892-10)		
						AB5110 (Fibre), 1.50mm (30-027147-10)		











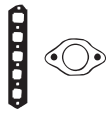

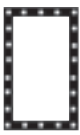

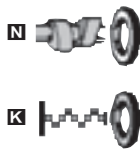

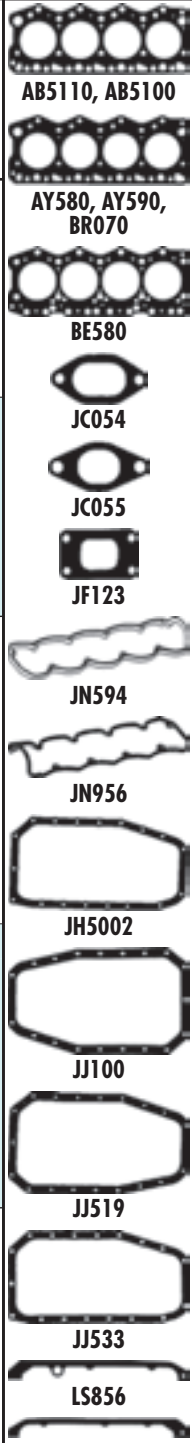







































								
HBS255  [22-17021B] M12x1.25x90mm (x8) M12x1.25x160mm (x14)	JC054  (31-024274-10) JC055  (31-025031-10)	JP069	JH5002 JJ519 (31-025623-00)	HR602  24-30670-61/0	NP067  50x70x10mm, FPM (50-307111-70) NP068  55x70x8mm, FPM (50-303186-00) NF885  [3] 70x159x16mm, FPM (50-307266-70) NF883  [3] 114x171x13mm, FPM (50-307265-70)	JR580 [11] LC281 [11] LC282 [11] LS858 [11] LS859 [11] KV927 [46]	AB5100, AB5110 AY290, AY300, AY310 AY580, AY590 AY680, AY690, AY700	
HBS255  [22-17021B] M12x1.25x90mm (x8) M12x1.25x160mm (x14)	JC054  (31-024274-10) JC055  (31-025031-10)	JN956	JH5002 JJ519 (31-025623-00)	HR602  24-30670-61/0	NP067  50x70x10mm, FPM (50-307111-70) NP068  55x70x8mm, FPM (50-303186-00) NF883  [3] 114x171x13mm, FPM (50-307265-70) NF886  [3] 100x120x16mm, FPM (50-307086-70)	HJ271 [39]  JR580 [11]	BE580 BX390, BX400, BX410, BX420	
HBS255  [22-17021B] M12x1.25x90mm (x8) M12x1.25x160mm (x14)	JC054  (31-024274-10) JC055  (31-025031-10)	JP069	JJ613	HR602  24-30670-61/0	NP067  50x70x10mm, FPM (50-307111-70) NP068  55x70x8mm, FPM (50-303186-00) NF885  [3] 70x159x16mm, FPM (50-307266-70) NF883  [3] 114x171x13mm, FPM (50-307265-70)	JR580 [11] LC280 [11] LC281 [11] LC282 [11] LS858 [11] LS859 [11] KV927 [46]	JC054 JC055 JF123	
HBS255  [22-17021B] M12x1.25x90mm (x8) M12x1.25x160mm (x14)	JC054  (31-024274-10) JC055  (31-025031-10)  JF123 (31-027523-00)	JP069	JH5002	HR602  24-30670-61/0	NP067  50x70x10mm, FPM (50-307111-70) NP068  55x70x8mm, FPM (50-303186-00) NF885  [3] 70x159x16mm, FPM (50-307266-70) NF883  [3] 114x171x13mm, FPM (50-307265-70) NF886  [3] 100x120x16mm, FPM (50-307086-70)	KD929 [72] [73] KD931 [72] [73] KD932 [72] [73] JR580 [11] LC280 [11] LC281 [11] LC282 [11] KV927 [46]	JN594 JN956 JP069	
HBS011  [22-51004B] M12x1.25x160mm (x10) M12x1.25x119mm (x12)	JC054  (31-024274-10) JC055  (31-025031-10)	JN956	JJ519 (31-025623-00) LS856 (50-025627-00)	HR602  24-30670-61/0	NP067  50x70x10mm, FPM (50-307111-70) NP068  55x70x8mm, FPM (50-303186-00) NF885  [3] 70x159x16mm, FPM (50-307266-70) NF883  [3] 114x171x13mm, FPM (50-307265-70)	JR580 [11] LC281 [11] LC282 [11] LS858 [11] LS859 [11] KK5599 [45] KV927 [46]	JH5002 JJ519	
HBS011  [22-51004B] M12x1.25x160mm (x10) M12x1.25x119mm (x12)	JC054  (31-024274-10) JC055  (31-025031-10)  JF123 (31-027523-00)	JN594 [71] (50-026037-00) JN956	JJ519 (31-025623-00) LS856 (50-025627-00) LS857 (50-025628-00)	HR602  24-30670-61/0	NP067  50x70x10mm, FPM (50-307111-70) NP068  55x70x8mm, FPM (50-303186-00) NA5055  70x90x10mm, FPM NF883  [3] 114x171x13mm, FPM (50-307265-70) NF886  [3] 100x120x16mm, FPM (50-307086-70)	HJ271 [39]  KD929 [72] [73] JR580 [11] LC281 [11] LC282 [11] LS858 [11] LS859 [11] KK5599 [45] KV927 [46]	JJ613 LS856 LS857	



KW/PS



Daily I 40.8 Diesel				01/83 → 06/89	22	BE580 (Fibre), 1.35mm (30-024116-10)	DE588▲ [109] (21-26037-23/0)	FY291 ▲ [12] (20-27426-00/0)
8140.61.200	2445	4	93.00		53/72			
Daily I 30.8 Diesel				01/78 → 12/89	23	BE580 (Fibre), 1.35mm (30-024116-10)	DE588▲ [109] (21-26037-23/0)	FY291 ▲ [12] (20-27426-00/0)
8140.61.200	2445	4	93.00		53/72			
Daily I 30.8 Diesel				01/92 → 08/98	24	BE580 (Fibre), 1.35mm (30-024116-10) AB5110 (Fibre), 1.50mm (30-027147-10)	DE588▲ [109] (21-26037-23/0)	
8140.67F	2449	4	93.00		60/81			
8140.07.2700	2499	4	93.00	Direct injection	55/75			
Daily I 35.1 Diesel				01/89 → 12/96	25	AB5100 (Fibre), 1.20mm [112] (30-027140-10) AY580 (Fibre), 1.30mm [112] (30-027141-10) AY590 (Fibre), 1.40mm [112] (30-027892-10) AB5110 (Fibre), 1.50mm (30-027147-10)	DS381▲ [111] (21-27141-20/0)	FB5100▲ [12] (20-27140-00/0)
Daily I 35.10 V, 35.10 C Diesel				01/85 → 12/89				
8140.27 S	2445	4	93.00		68/92			
8140.21.200	2499	4	93.00		68/92			
8140.47 R	2499	4	93.00		80/109			
Daily I 35.10 V, 35.10 C Diesel				01/89 → 08/98	26	AB5100 (Fibre), 1.20mm [112] (30-027140-10) BR070 (Fibre), 1.20mm (30-025645-10) AY580 (Fibre), 1.30mm [112] (30-027141-10) AY590 (Fibre), 1.40mm [112] (30-027892-10) AB5110 (Fibre), 1.50mm (30-027147-10)	DS381▲ [111] (21-27141-20/0)	FB5100▲ [12] (20-27140-00/0) FB5101▲ [167] (20-27140-01/0)
Daily I 40.12 Diesel				10/90 → 04/96				
Daily I 40.12 V Diesel				10/90 → 04/96				
Daily I 49.10 Diesel				01/89 → 04/96				
Daily I 49.10 K Diesel				01/89 → 04/96				
Daily I 49.12 Diesel				06/90 → 04/96				
Daily I 49.12 K Diesel				06/90 → 04/96				
Daily I 49.12 V Diesel				06/90 → 04/96				
Daily I 59.12 Diesel				05/91 → 04/96				
Daily I 59.12 K Diesel				05/91 → 04/96				
Daily I 59.12 V Diesel				05/91 → 04/96				
Daily I A 40.10 Diesel				01/91 → 12/96				
Daily I A 45.10 Diesel				01/91 → 04/96				
8140.27.2700/ 8140.27.2720	2499	4	93.00		76/103			
8140.47R.2790	2499	4	93.00	Direct Injection	76/103			
8140.47 R	2499	4	93.00		80/109			
8140.47.2700/ 8140.47.2711/ 8140.47.2721	2499	4	93.00	Direct Injection	85/116			











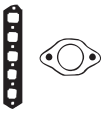

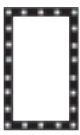

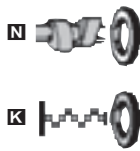

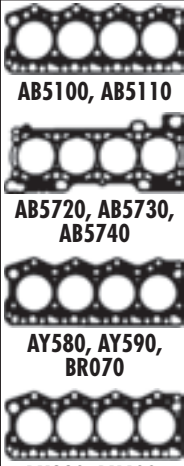

























































								
HBS011  (22-51004B) M12x1.25x160mm (x10) M12x1.25x119mm (x12)	JC054  (31-024274-10) JC055  (31-025031-10)	JN594 [71] (50-026037-00)	JJ100 LS856 (50-025627-00) LS857 (50-025628-00)	HR602  24-30670-61/0 HR782 	NP067  50x70x10mm, FPM (50-307111-70) NP068  55x70x8mm, FPM (50-303186-00) NF833  (50-305860-50) NA5055  70x90x10mm, FPM	KA292 [13] KA546 [13] KA547 [13] HJ271 [39]  JR580 [11]	AB5110, AB5100 AY580, AY590, BR070 BE580 JC054 JC055 JF123	
HBS011  (22-51004B) M12x1.25x160mm (x10) M12x1.25x119mm (x12)	JC054  (31-024274-10) JC055  (31-025031-10)	JN594 [71] (50-026037-00)	JJ100 LS856 (50-025627-00) LS857 (50-025628-00)	HR602  24-30670-61/0 HR782 	NP067  50x70x10mm, FPM (50-307111-70) NP068  55x70x8mm, FPM (50-303186-00) NF833  (50-305860-50) NA5055  70x90x10mm, FPM	KA292 [13] KA546 [13] KA547 [13] HJ271 [39]  JR580 [11]	JN594 JN956 JH5002 JJ100 JS519 LS856 LS857	
HBS011  (22-51004B) M12x1.25x160mm (x10) M12x1.25x119mm (x12)	JC054  (31-024274-10) JC055  (31-025031-10)	JN956	JJ519 (31-025623-00)	HR602  24-30670-61/0	NP067  50x70x10mm, FPM (50-307111-70) NP068  55x70x8mm, FPM (50-303186-00) NF885  [3] 70x159x16mm, FPM (50-307266-70) NF883  [3] 114x171x13mm, FPM (50-307265-70) NF886  [3] 100x120x16mm, FPM (50-307086-70)	JR580 [11] LC281 [11] LC282 [11] LS858 [11] LS859 [11] KK5599 [45] KV927 [46]	JN594 JN956 JH5002 JJ100 JS519 LS856 LS857	
HBS011  (22-51004B) M12x1.25x160mm (x10) M12x1.25x119mm (x12)	JC054  (31-024274-10) JC055  (31-025031-10) JF123  (31-027523-00)	JN594 [71] (50-026037-00) JN956	JJ519 (31-025623-00) LS856 (50-025627-00) LS857 (50-025628-00)	HR602  24-30670-61/0	NP067  50x70x10mm, FPM (50-307111-70) NP068  55x70x8mm, FPM (50-303186-00) NA5055  70x90x10mm, FPM NF883  [3] 114x171x13mm, FPM (50-307265-70) NF886  [3] 100x120x16mm, FPM (50-307086-70)	HJ271 [39]  KD929 [72][73] JR580 [11] LC281 [11] LC282 [11] LS858 [11] LS859 [11] KK5599 [45] KV927 [46]	JN594 JN956 JH5002 JJ100 JS519 LS856 LS857	
HBS011  (22-51004B) M12x1.25x160mm (x10) M12x1.25x119mm (x12)	JC054  (31-024274-10) JC055  (31-025031-10)	JN956	JH5002 JJ519 (31-025623-00) JJ533 LS856 (50-025627-00) LS857 (50-025628-00)	HR602  24-30670-61/0 HR781 	NP067  50x70x10mm, FPM (50-307111-70) NP068  55x70x8mm, FPM (50-303186-00) NA5055  70x90x10mm, FPM NF883  [3] 114x171x13mm, FPM (50-307265-70) NF886  [3] 100x120x16mm, FPM (50-307086-70)	KD929 [72][73] KD931 [72][73] JR580 [11] LC280 [11] LC281 [11] LC282 [11] LS858 [11] LS859 [11] KK5599 [45] KV927 [46]	JN594 JN956 JH5002 JJ100 JS519 LS856 LS857	



KW/PS



Daily I 45.10 Diesel		01/85 → 12/89		27		AB5100 (Fibre), 1.20mm [112] (30-027140-10) AY580 (Fibre), 1.30mm [112] (30-027141-10) AY590 (Fibre), 1.40mm [112] (30-027892-10) AB5110 (Fibre), 1.50mm (30-027147-10)	DS381▲ [111] (21-27141-20/0)	FB5100▲ [12] (20-27140-00/0)
Daily I 45.10 V Diesel		01/85 → 12/89						
Daily I 49.10 V Diesel		01/85 → 12/89						
8140.21.200	2499	4	93.00		68/92			
Daily I 49.10 V Diesel		01/89 → 04/96		28		AB5100 (Fibre), 1.20mm [112] (30-027140-10) BR070 (Fibre), 1.20mm (30-025645-10) AY580 (Fibre), 1.30mm [112] (30-027141-10) AY590 (Fibre), 1.40mm [112] (30-027892-10) AB5110 (Fibre), 1.50mm (30-027147-10)	DS381▲ [111] (21-27141-20/0)	FB5100▲ [12] (20-27140-00/0) FB5101▲ [167] (20-27140-01/0)
Daily I 49.10 V Diesel		01/89 → 04/96						
Daily I 49.10 V Diesel		01/89 → 04/96		Direct Injection				
8140.27.2700	2499	4	93.00		76/103			
8140.47R.2790	2499	4	93.00		76/103			
Daily I 30.10 Diesel		01/98 →		29		BX390 (Fibre), 1.20mm [71] (30-027867-00) BX400 (Fibre), 1.30mm [71] (30-027868-00) BX410 (Fibre), 1.40mm [71] (30-027883-00) BX420 (Fibre), 1.50mm [71] (30-027884-00)	DX391▲ (21-27867-21/0)	GX410▲ (20-27867-03/0)
Daily I 30.10 C Diesel		01/97 →						
Daily I 35.10 Diesel		01/96 →						
Daily I 40.10 WV, 40.10 WC Diesel		01/97 →						
Daily I 49.10 Diesel		05/96 →						
Daily I 49.10 K Diesel		05/96 →						
Daily I A 45.10 Diesel		05/96 →						
8140.23.	2798	4	94.40	Direct Injection	76/103			
Daily I 30.10 V, 30.10 C Diesel		01/97 →		30		BX390 (Fibre), 1.20mm [71] (30-027867-00) BX400 (Fibre), 1.30mm [71] (30-027868-00) BX410 (Fibre), 1.40mm [71] (30-027883-00) BX420 (Fibre), 1.50mm [71] (30-027884-00)	DX390▲■ (21-27867-20/0)	GX391▲ (20-27867-01/0)
Daily I 30.10 V, 30.10 C Diesel		01/97 →						
Daily I 30.10 V, 30.10 C Diesel		01/97 →		Direct Injection				
8140.23.	2798	4	94.40	Direct Injection	76/103			
Daily I 49.12 Diesel		05/96 →		31		BX390 (Fibre), 1.20mm [71] (30-027867-00) BX400 (Fibre), 1.30mm [71] (30-027868-00) BX410 (Fibre), 1.40mm [71] (30-027883-00) BX420 (Fibre), 1.50mm [71] (30-027884-00)	DX390▲■ (21-27867-20/0) DX400▲ (21-27867-23/0)	GX390▲ (20-27867-00/0)
Daily I 49.12 K Diesel		05/96 →						
Daily I 49.12 V Diesel		05/96 →						
Daily I 59.12 Diesel		05/96 →						
Daily I 59.12 K Diesel		05/96 →						
Daily I 59.12 V Diesel		05/96 →						
Daily I A 45.12 Diesel		05/96 →						
8140.43.	2798	4	94.40	Direct Injection	90/122			
Daily II 29L10 Diesel		09/02 →		32		AB5720 (MLS), 1.10mm (30-029317-00) AB5730 (MLS), 1.20mm (30-029318-00) AB5740 (MLS), 1.30mm (30-029319-00)	CB5720▲■ (21-29319-20/0)	FB5721▲■ (20-29319-01/0)
Daily II 29L10 Diesel		09/02 →						
Daily II 29L10 Diesel		09/02 →		Direct Injection				
F1AE 0481 A	2287	4	88.00	Direct Injection	70/95			











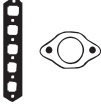

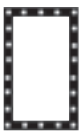

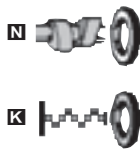

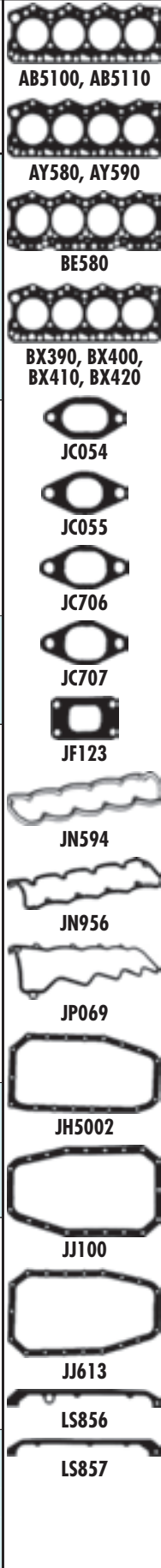





































								
HBS011  (22-51004B) M12x1.25x160mm (x10) M12x1.25x119mm (x12)	JC054  (31-024274-10) JC055  (31-025031-10)  JF123 (31-027523-00)	JN594 [71] (50-026037-00) JN956	JJ519 (31-025623-00) LS856 (50-025627-00) LS857 (50-025628-00)	HR602  24-30670-61/0	 NP067  50x70x10mm, FPM (50-307111-70)  NP068  55x70x8mm, FPM (50-303186-00)  NF883  [3] 114x171x13mm, FPM (50-307265-70)  NF886  [3] 100x120x16mm, FPM (50-307086-70)	HJ271 [39]  KD929 [72] [73] JR580 [11] LC281 [11] LC282 [11] LS858 [11] LS859 [11] KK5599 [45] KV927 [46]	AB5100, AB5110 AB5720, AB5730, AB5740 AY580, AY590, BR070 BX390, BX400, BX410, BX420 JC054 JC055 JF123 JM5201 JN594 JN956 JP069 JH5002 JJ519 JJ613 LS856 LS857	
HBS011  (22-51004B) M12x1.25x160mm (x10) M12x1.25x119mm (x12)	JC054  (31-024274-10) JC055  (31-025031-10)	JN956	JH5002 JJ519 (31-025623-00)	HR602  24-30670-61/0 HR781 	 NP067  50x70x10mm, FPM (50-307111-70)  NP068  55x70x8mm, FPM (50-303186-00)  NA5055  70x90x10mm, FPM  NF883  [3] 114x171x13mm, FPM (50-307265-70)  NF886  [3] 100x120x16mm, FPM (50-307086-70)	KD929 [72] [73] KD931 [72] [73] JR580 [11] LC280 [11] LC281 [11] LC282 [11] LS859 [11] KK5599 [45] KV927 [46]	JM5201 JN594 JN956 JP069 JH5002 JJ519 JJ613 LS856 LS857	
HBS255  (22-17021B) M12x1.25x90mm (x8) M12x1.25x160mm (x14)	JC054  (31-024274-10) JC055  (31-025031-10)	JN956	JH5002 JJ519 (31-025623-00)	HR602  24-30670-61/0	 NP067  50x70x10mm, FPM (50-307111-70)  NP068  55x70x8mm, FPM (50-303186-00)  NF885  [3] 70x159x16mm, FPM (50-307266-70)  NF883  [3] 114x171x13mm, FPM (50-307265-70)	JM5201 JN594 JN956 JP069 JH5002 JJ519 JJ613 LS856 LS857		
HBS255  (22-17021B) M12x1.25x90mm (x8) M12x1.25x160mm (x14)	JC054  (31-024274-10) JC055  (31-025031-10)	JN594 [71] (50-026037-00)		HR602  24-30670-61/0	 NP067  50x70x10mm, FPM (50-307111-70)  NP068  55x70x8mm, FPM (50-303186-00)  NF885  [3] 70x159x16mm, FPM (50-307266-70)  NF883  [3] 114x171x13mm, FPM (50-307265-70)	JM5201 JN594 JN956 JP069 JH5002 JJ519 JJ613 LS856 LS857		
HBS255  (22-17021B) M12x1.25x90mm (x8) M12x1.25x160mm (x14)	JC054  (31-024274-10) JC055  (31-025031-10)	JP069	JJ613	HR602  24-30670-61/0	 NP067  50x70x10mm, FPM (50-307111-70)  NP068  55x70x8mm, FPM (50-303186-00)  NF885  [3] 70x159x16mm, FPM (50-307266-70)  NF883  [3] 114x171x13mm, FPM (50-307265-70)	JM5201 JN594 JN956 JP069 JH5002 JJ519 JJ613 LS856 LS857		
HBS251  (22-17020B) M14x1.50x193mm (x6) M11x1.50x133mm (x4)	JD5337  (31-029921-00)	JM5201 [165] (50-029918-00) (Rubber/Metal) →08/04 JM5205 50-029938-00 (Rubber) 08/04→	JH5081 (31-029964-00)					JM5201 JN594 JN956 JP069 JH5002 JJ519 JJ613 LS856 LS857



KW/PS



Daily II 29L11 Diesel 05/99 → 33						BX390 (Fibre), 1.20mm [71] (30-027867-00) BX400 (Fibre), 1.30mm [71] (30-027868-00) BX410 (Fibre), 1.40mm [71] (30-027883-00) BX420 (Fibre), 1.50mm [71] (30-027884-00)	DX391▲ (21-27867-21/0)	GX390▲ (20-27867-00/0)
Daily II 35S11, 35C11 Diesel 05/99 →								
Daily II 50C11 Diesel 05/99 →								
8140.43B/8140.43C	2798	4	94.40	Direct Injection	78/106			
Daily II 29L13 Diesel 11/01 → 34						BX390 (Fibre), 1.20mm [71] (30-027867-00) BX400 (Fibre), 1.30mm [71] (30-027868-00) BX410 (Fibre), 1.40mm [71] (30-027883-00) BX420 (Fibre), 1.50mm [71] (30-027884-00)	DX392▲ (21-27867-22/0)	GX392▲ (20-27867-02/0)
Daily II 35S13, 35C13 Diesel 05/99 →								
Daily II 50C13 Diesel 05/99 →								
8140.43S	2798	4	94.40	Direct Injection, SOHC	92/125			
Daily II 29L13 Diesel 05/01 → 35						BX420 (Fibre), 1.50mm [71] (30-027884-00)	DX391▲ (21-27867-21/0)	GX392▲ (20-27867-02/0)
8140.43S	2798	4	94.40	Direct Injection, SOHC	92/125			
Daily III 35C15 Diesel 01/94 → 36						AG6050 (MLS), 1.10mm (30-029971-00) AG7300 (MLS), 1.30mm (30-029973-00) AG6060 (MLS), 1.20mm (30-029972-00)		
Daily III 35C18 Diesel 05/06 →								
Daily III 40C15 Diesel 05/06 →								
Daily III 40C18 Diesel 05/06 →								
Daily III 45C15 Diesel 05/06 →								
Daily III 45C18 Diesel 05/06 →								
Daily III 50C15 Diesel 05/06 →								
Daily III 50C18 Diesel 05/06 →								
Daily III 60C18 Diesel 05/06 →								
Daily III 65C18 Diesel 05/06 →								
F1CE 0481 FA/ F1CE 0481 HC	2998	4	95.80	Direct Injection, DOHC	107/146			
F1CE 0481 HA	2998	4	95.80	Direct Injection, DOHC	130/176			
DI 50 35.8 Diesel 37						BE580 (Fibre), 1.35mm (30-024116-10)	DE588▲ [109] (21-26037-23/0)	FY291▲ [12] (20-27426-00/0)
8140.61.300	2445	4	93.00					
Grinta Daily 2.5 TD Diesel 01/85 → 12/89 38						AB5100 (Fibre), 1.20mm [112] (30-027140-10) AY580 (Fibre), 1.30mm [112] (30-027141-10) AY590 (Fibre), 1.40mm [112] (30-027892-10) AB5110 (Fibre), 1.50mm (30-027147-10)	DS381▲ [111] (21-27141-20/0)	FB5100▲ [12] (20-27140-00/0)
8140.21	2445	4	93.00	Turbo				
Grinta Daily 28.8 Diesel 01/79 → 12/89 39						BE580 (Fibre), 1.35mm (30-024116-10)	DE588▲ [109] (21-26037-23/0)	FY291▲ [12] (20-27426-00/0)
Grinta Daily 32.8 Diesel 01/79 → 12/89								
Grinta Daily 35.8 Diesel 01/79 → 12/89								
Grinta Daily 40.8 Diesel 01/79 → 12/89								
8140.61.300	2445	4	93.00					











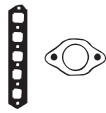

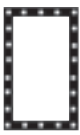

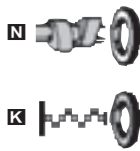

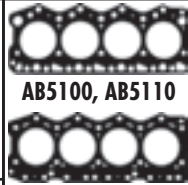



































































								
HBS011  (22-51004B) M12x1.25x160mm (x10) M12x1.25x119mm (x12)	JC054  (31-024274-10) JC055  (31-025031-10) JF123  (31-027523-00)	JN956	JJ613	HR602  24-30670-61/0	NP067  50x70x10mm, FPM (50-307111-70) NP068  55x70x8mm, FPM (50-303186-00) NF885  [3] 70x159x16mm, FPM (50-307266-70) NF883  [3] 114x171x13mm, FPM (50-307265-70)	KD929 [72][73] KD931 [72][73] KD932 [72][73] JR580 [11] LC280 [11] LC281 [11] LC282 [11] KK5599 [45] KV927 [46]	AB5100, AB5110 AY580, AY590 BE580 BX390, BX400, BX410, BX420 KV927 [46]	
HBS011  (22-51004B) M12x1.25x160mm (x10) M12x1.25x119mm (x12)	JC054  (31-024274-10) JC055  (31-025031-10)	JP069	JH5002	HR602  24-30670-61/0	NP067  50x70x10mm, FPM (50-307111-70) NP068  55x70x8mm, FPM (50-303186-00) NF885  [3] 70x159x16mm, FPM (50-307266-70) NF883  [3] 114x171x13mm, FPM (50-307265-70)		JC054 JC055 JC706 JC707 JF123	
HBS011  (22-51004B) M12x1.25x160mm (x10) M12x1.25x119mm (x12)	JC054  (31-024274-10) JC055  (31-025031-10)	JP069	JH5002				JF123	
HBS464 (22-17028B)							JN594 JN956 JP069	
HBS011  (22-51004B) M12x1.25x160mm (x10) M12x1.25x119mm (x12)	JC054  (31-024274-10) JC055  (31-025031-10)	JN594 [71] (50-026037-00)	JJ100 LS856 (50-025627-00) LS857 (50-025628-00)	HR602  24-30670-61/0 HR782 	NP067  50x70x10mm, FPM (50-307111-70) NP068  55x70x8mm, FPM (50-303186-00) NA5055  70x90x10mm, FPM	HJ271 [39]  JR580 [11]	JH5002 JJ100	
HBS011  (22-51004B) M12x1.25x160mm (x10) M12x1.25x119mm (x12)	JC054  (31-024274-10) JC706  JC707  (31-026039-00)	JN594 [71] (50-026037-00)	JJ100 LS856 (50-025627-00) LS857 (50-025628-00)	HR602  24-30670-61/0	NP067  50x70x10mm, FPM (50-307111-70) NP068  55x70x8mm, FPM (50-303186-00) NA5055  70x90x10mm, FPM	HJ271 [39]  JR580 [11] LS858 [11] LS859 [11]	JJ100 JJ613 LS856	
HBS011  (22-51004B) M12x1.25x160mm (x10) M12x1.25x119mm (x12)	JC054  (31-024274-10) JC055  (31-025031-10)	JN594 [71] (50-026037-00)	JJ100 LS856 (50-025627-00) LS857 (50-025628-00)	HR602  24-30670-61/0 HR782 	NP067  50x70x10mm, FPM (50-307111-70) NP068  55x70x8mm, FPM (50-303186-00) NA5055  70x90x10mm, FPM	HJ271 [39]  JR580 [11]	LS857	



KW/PS



Grinta Daily 2.5L D Diesel		01/89 → 12/94		40		AY290 (Fibre), 1.60mm [112] (30-027426-00) AY300 (Fibre), 1.70mm [112] (30-026654-20) AY310 (Fibre), 1.80mm [112] (30-026655-20)		DE588▲ [109] (21-26037-23/0)		FY291▲ [12] (20-27426-00/0)	
8140.67 (290B7W)/8144.67	2500	4	93.00	Indirect Injection, Turbo							
Metano 35.11 Diesel		07/99 →		41		BX390 (Fibre), 1.20mm [71] (30-027867-00) BX400 (Fibre), 1.30mm [71] (30-027868-00) BX410 (Fibre), 1.40mm [71] (30-027883-00) BX420 (Fibre), 1.50mm [71] (30-027884-00)		CY680▲ (21-28607-20/0)		FY691▲ [147] (20-28607-01/0)	
8149.03.3971	2798	4	94.40	Sofim, Direct Injection							
Metano 49.11 Diesel		07/99 →		42		BX390 (Fibre), 1.20mm [71] (30-027867-00) BX400 (Fibre), 1.30mm [71] (30-027868-00) BX410 (Fibre), 1.40mm [71] (30-027883-00) BX420 (Fibre), 1.50mm [71] (30-027884-00)		DX392▲ (21-27867-22/0)		GX392▲ (20-27867-02/0)	
8140.43M.4300/ 8140.43M.4320/ 8140.43M.4330 8140.43S	2800	4	94.40	Common Rail, Turbo Intercooled		107/146					
	2800	4	94.40	Direct Injection, SOHC, Turbo Intercooled, Euro 3 (D3)		107/146					
Turbo Daily 40.10 4x4 Diesel		12/81 →		43		BR070 (Fibre), 1.20mm (30-025645-10)		DR073▲		FB5102▲ [12] (20-27140-02/0)	
8140.27.210/ 8140.27.213 8140.27.218	2445	4	93.00	Sofim, Direct injection, Turbo							
	2445	4	93.00								
Turbo Daily 49.10 S Diesel		01/89 →		44		AB5100 (Fibre), 1.20mm [112] (30-027140-10) AY580 (Fibre), 1.30mm [112] (30-027141-10) AY590 (Fibre), 1.40mm [112] (30-027892-10) AB5110 (Fibre), 1.50mm (30-027147-10)		DS381▲ [111] (21-27141-20/0)		FB5100▲ [12] (20-27140-00/0)	
8140.21	2445	4	93.00	Turbo							
Turbo Daily A 40.10 Diesel		01/89 →		45		BR070 (Fibre), 1.20mm (30-025645-10)		DR073▲		FB5102▲ [12] (20-27140-02/0)	
8140.21.212/ 8140.21.290	2445	4	93.00	Sofim, Direct injection, Turbo							
Turbo Daily A 45.10 Diesel		01/91 →		46		AY580 (Fibre), 1.30mm [112] (30-027141-10) AY590 (Fibre), 1.40mm [112] (30-027892-10)		DS381▲ [111] (21-27141-20/0)		FB5100▲ [12] (20-27140-00/0)	
8140.27R.2700	2499	4	93.00	Turbo		70-67/ 95-92					
8140.27S.2700	2499	4	93.00	Sofim, Turbo		70-67/ 95-92					











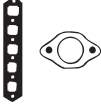

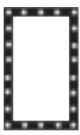

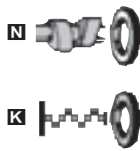





























								 AB5100, AB5110	 LS856	 LS857
HBS011  (22-51004B) M12x1.25x160mm (x10) M12x1.25x119mm (x12)	JC054  (31-024274-10) JC055  (31-025031-10)	JN462 (50-024272-00) JN594 [71] (50-026037-00)	JJ100 LS856 (50-025627-00) LS857 (50-025628-00)	HR602  24-30670-61/0	NP067  50x70x10mm, FPM (50-307111-70) NP068  55x70x8mm, FPM (50-303186-00) NA5055  70x90x10mm, FPM NF883  [3] 114x171x13mm, FPM (50-307265-70)	KA546 [13] KA547 [13] HJ271 [39]  JR580 [11] KL221 [11] LS858 [11] LS859 [11] KV927 [46]	 AY290, AY300, AY310  BR070, AY580, AY590  BX390, BX400, BX410, BX420			
HBS255  (22-17021B) M12x1.25x90mm (x8) M12x1.25x160mm (x14)	JC054  (31-024274-10) JC055  (31-025031-10)	JP069	JH5002 JJ519 (31-025623-00)	HR602  24-30670-61/0	NP067  50x70x10mm, FPM (50-307111-70) NP068  55x70x8mm, FPM (50-303186-00) NF885  [3] 70x159x16mm, FPM (50-307266-70) NF883  [3] 114x171x13mm, FPM (50-307265-70)	JR580 [11] LC281 [11] LC282 [11] LS858 [11] LS859 [11]	 JC054  JC055  JC706  JC707  JF123			
HBS255  (22-17021B) M12x1.25x90mm (x8) M12x1.25x160mm (x14)	JC054  (31-024274-10) JC055  (31-025031-10)  JF123 (31-027523-00)	JP069	JH5002	HR602  24-30670-61/0	NP067  50x70x10mm, FPM (50-307111-70) NP068  55x70x8mm, FPM (50-303186-00) NF885  [3] 70x159x16mm, FPM (50-307266-70) NF886  [3] 100x120x16mm, FPM (50-307086-70) NF883  [3] 114x171x13mm, FPM (50-307265-70)	KD929 [72][73] KD931 [72][73] KD932 [72][73] JR580 [11] LC280 [11] LC281 [11] LC282 [11] KV927 [46]	 JN462  JN594  JN956			
HBS011  (22-51004B) M12x1.25x160mm (x10) M12x1.25x119mm (x12)	JC054  (31-024274-10) JC706  JC707  (31-026039-00)	JN594 [71] (50-026037-00)	JJ214 LS856 (50-025627-00) LS857 (50-025628-00)	HR602  24-30670-61/0 HR782 	NP067  50x70x10mm, FPM (50-307111-70) NP068  55x70x8mm, FPM (50-303186-00) NF885  [3] 70x159x16mm, FPM (50-307266-70) NF853  100x118x10mm, FPM (50-307096-70)	HJ271 [39]  KD929 [72][73] JR580 [11] LS858 [11] KV927 [46]	 JP069  JH5002			
HBS011  (22-51004B) M12x1.25x160mm (x10) M12x1.25x119mm (x12)	JC054  (31-024274-10) JC706  JC707  (31-026039-00)	JN594 [71] (50-026037-00)	JJ100 LS856 (50-025627-00) LS857 (50-025628-00)	HR602  24-30670-61/0 HR782 	NP067  50x70x10mm, FPM (50-307111-70) NP068  55x70x8mm, FPM (50-303186-00) NA5055  70x90x10mm, FPM NF853  100x118x10mm, FPM (50-307096-70)	HJ271 [39]  JR580 [11] LS858 [11] LS859 [11]	 JJ100			
HBS011  (22-51004B) M12x1.25x160mm (x10) M12x1.25x119mm (x12)	JC054  (31-024274-10) JC706  JC707  (31-026039-00)	JN594 [71] (50-026037-00)	JJ214 LS856 (50-025627-00) LS857 (50-025628-00)	HR602  24-30670-61/0	NP067  50x70x10mm, FPM (50-307111-70) NP068  55x70x8mm, FPM (50-303186-00) NA5055  70x90x10mm, FPM NF883  [3] 114x171x13mm, FPM (50-307265-70) NF886  [3] 100x120x16mm, FPM (50-307086-70)	KD929 [72][73] JR580 [11]	 JJ214  JJ519			



KW/PS



Turbo Daily A 40.10 4x4 Diesel				01/89 →		47		
8140.27S.2801/ 8140.27S.2811/ 8140.27S.2885 8140.27S.3811	2499	4	93.00	Sofim, Direct injection, Turbo		AB5100 (Fibre), 1.20mm [112] (30-027140-10) AY580 (Fibre), 1.30mm [112] (30-027141-10) AY590 (Fibre), 1.40mm [112] (30-027892-10) AB5110 (Fibre), 1.50mm (30-027147-10)	DR073 ▲	FB5102 ▲ [12] (20-27140-02/0)
Turbo Daily 2.8L TD Diesel				01/96 →		48		
8140.23.2585/ 8140.23.3700 8140.43.2585	2799	4	94.40	Sofim, Direct Injection, Turbo Intercooled	84/114	BX390 (Fibre), 1.20mm [71] (30-027867-00) BX400 (Fibre), 1.30mm [71] (30-027868-00) BX410 (Fibre), 1.40mm [71] (30-027883-00) BX420 (Fibre), 1.50mm [71] (30-027884-00)	DX391 ▲ (21-27867-21/0)	GX410 ▲ (20-27867-03/0)
8140.43.3700/ 8140.43.3900 (S9WA7)	2799	4	94.40	Sofim, Direct Injection, Turbo Intercooled	84/114			

								 AB5100, AB5110	 JN594
HBS011  (22-51004B) M12x1.25x160mm (x10) M12x1.25x119mm (x12)	JC054  (31-024274-10) JC055  (31-025031-10)  JF123 (31-027523-00)	JN594 [71] (50-026037-00)	JJ214	HR602  24-30670-61/0 HR781 	 NP067  50x70x10mm, FPM (50-307111-70)  NP068  55x70x8mm, FPM (50-303186-00)  NA5055  70x90x10mm, FPM  NF853  100x118x10mm, FPM (50-307096-70)	KD929 [72] [73] JR580 [11] LC281 [11] LC282 [11] LS858 [11] LS859 [11] KV927 [46]	 AY580, AY590	 JN956	
HBS255  (22-17021B) M12x1.25x90mm (x8) M12x1.25x160mm (x14)	JC054  (31-024274-10) JC055  (31-025031-10)	JN956	JH5002 JJ519 (31-025623-00)	HR602  24-30670-61/0	 NP067  50x70x10mm, FPM (50-307111-70)  NP068  55x70x8mm, FPM (50-303186-00)  NF886 [3] 100x120x16mm, FPM (50-307086-70)  NF883 [3] 114x171x13mm, FPM (50-307265-70)	HJ271 [39]  JR580 [11]	 BX390, BX400, BX410, BX420	 JH5002	
	JC054 						 JC054	 JJ214	
	JC055 						 JC055	 JJ519	
	JF123 						 JF123		



CC



9



CC



9











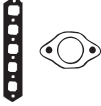

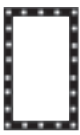























































































9BPMNA	Petrol	3239	6	91.00	13
9DPANA	Petrol	3590	6	91.00	14
9EPCNA	Petrol	3980	6	91.00	15
9EPCNA	Petrol	3980	6	91.00	30
9KPDRB	Petrol	3980	6	86.00	25
AJ 16 (4.0)	Petrol	3980	6	91.00	29
AJ 16 (9JPGRB)	Petrol	3239	6	91.00	12
AJ 6	Petrol	3980	6	91.00	23
AJ 6	Petrol	3980	6	91.00	30
AJ 6 (3.6, 156KW)	Petrol	3590	6		14
AJ 6 (3.6, 156KW)	Petrol	3590	6		28
AJ27 (3.2)	Petrol	3252	8	86.00	17
AJ34 (4.2)	Petrol	4196	8	86.00	10
AJ34 (4.2)	Petrol	4196	8	86.00	19
AJ34 (4.2)	Petrol	4196	8	86.00	35
AJ34 (4.2)	Petrol	4196	8	86.00	36
AJ34 (4.2SC)	Petrol	4196	8	86.00	10
AJ34 (4.2SC)	Petrol	4196	8	86.00	26
AJ34 (4.2SC)	Petrol	4196	8	86.00	35
AJ34 (4.2SC)	Petrol	4196	8	86.00	36
AJ67 (3.0)	Petrol	2967	6	89.00	37
AJ-V6	Petrol	2967	6	89.00	11
AJ-V6	Petrol	2967	6	89.00	8
AJ-V8	Petrol	3996	8	86.00	9
BC	Petrol	3996	8	86.00	18
CC	Petrol	3996	8	86.00	33
CE	Petrol	3996	8	86.00	33
DC	Petrol	3996	8	86.00	24
EC	Petrol	3996	8	86.00	34
V 12 (75-79)	Petrol	5343	12	90.00	1
V 12 (75-79)	Petrol	5343	12	90.00	20
V 12 (75-79)	Petrol	5343	12	90.00	31
V 12 (75-79)	Petrol	5343	12	90.00	7
V12HE	Petrol	5343	12	90.00	2
V12HE	Petrol	5343	12	90.00	21
V12HE	Petrol	5343	12	90.00	27
V12HE	Petrol	5343	12	90.00	32
XK (3.8)	Petrol	3781	6	86.99	5
XK (4.2)	Petrol	4235	6	92.07	16
XK (4.2)	Petrol	4235	6	92.07	3
XK (4.2)	Petrol	4235	6	92.07	4
XK (4.2)	Petrol	4235	6	92.07	6



KW/PS



Daimler Double Six Series I/II/III						07/72 → 12/81	1		CH831 ■ →05/75 CH832 ■ →06/75	EH831
V 12	5343	12	90.00	SOHC, V12	211/287					
Daimler Double Six Series III						01/81 → 11/92	2	BE890 (Fibre) ■ BE880 (Fibre) ■	DE880 ■ EH831	
V12HE	5343	12	90.00	SOHC, V12	197/268					
Daimler Sovereign 4.2L Series II						09/73 → 02/79	3	BJ020 (Fibre)	DJ022 ■ →08/74 DJ023 ■ 09/74 → EH690	
XK (4.2)	4235	6	92.07		124/168					
Daimler Sovereign 4.2L Series III						09/79 → 07/86	4	BJ020 (Fibre)	DJ024 ■ EH690	
XK (4.2)	4235	6	92.07		124/168					
E-Type Convertible 3.8L Series I						04/61 → 07/64	5	AE540 (Steel)	CE542 ■ ○ EE532	
XK (3.8)	3781	6	86.99		195/265					
E-Type 4.2L Series I/II						01/65 → 12/71	6	BJ020 (Fibre) 1968 →	CG571 ■ ○ →1968 DJ021 ■ 1968 → EG571 →1968 EH690 1968 →	
XK (4.2)	4235	6	92.07		124/168					
E-Type Series III						01/71 → 12/75	7		CH831 ■ →05/75 CH832 ■ 06/75 → EH831	
V 12	5343	12	90.00	SOHC, V12	211/287					
S-Type 3.0L V6						01/99 →	8	AC5400 (MLS) ■ (30-029499-00) AC5390 (MLS) ■ (30-029498-00)		
AJ-V6	2967	6	89.00	Injection, DOHC, V6	175/238					
S-Type 4.0L V8						01/99 → 04/02	9	AC5270 (Fibre) ■ (30-029470-00) →03/00 AC5260 (Fibre) ■ (30-029469-00) →03/00 AC5500 (MLS) ■ (30-029611-00) 04/00 → AC5510 (MLS) ■ (30-029610-00) 04/00 →	CC5260 (21-29470-20/0) →03/00	
AJ-V8	3996	8	86.00	Injection, DOHC, V8	203/276					
S-Type 4.2L V8						04/02 →	10	AC5500 (MLS) ■ (30-029611-00) AC5510 (MLS) ■ (30-029610-00)		
AJ34 (4.2) AJ34 (4.2SC)	4196 4196	8 8	86.00 86.00		219/298 291/396					
XJ 6 3.0L						05/03 →	11	AC5400 (MLS) ■ (30-029499-00) AC5390 (MLS) ■ (30-029498-00)		
AJ-V6	2967	6	89.00	Injection, DOHC, V6	175/238					
XJ 6 3.2L						11/94 → 07/97	12	BT070 (Fibre) (30-029543-00)	DT072 ■ (21-29543-21/0)	
AJ 16 (9JPGRB)	3239	6	91.00	DOHC	155/211					
XJ 6 3.2L 24V						09/90 → 11/94	13	BT070 (Fibre) (30-029543-00)	DT070 ■ → Eng.116000 DT071 ■ (21-29543-20/0) Eng.116001 →	
9BPMNA	3239	6	91.00	DOHC	146/199					

						 		
		JA689  (x12) ⊙ JE231 (x4)	JM537  JM536 	JH485  JH501 	HR299  (x2)	 NB584  54x73x12.4mm, NBR (50-319429-00)		 AC5260  AC5270  AC5390  AC5400  AC5500  AC5510
		JD144  (x12) JA689  (x12) ⊙ JE231 (x4)	JM537  JM536 	JH485  JH501 	HR299  (x2)	 NB584  54x73x12.4mm, NBR (50-319429-00)		 JM537  JN180  JN927  JH485
		JA793  JA272  (x2) ⊙ JE231 (x2)	JM448  →08/74 JM447  →08/74 JN180 (x2) 09/74→	HC425 	HR299 	 NA422  50.8x69.9x12.7mm, NBR		 JH485  JH501
		JA793  JA272  (x2) ⊙ JE231 (x2)	JN180 (x2)	HC425 	HR299 	 NA422  50.8x69.9x12.7mm, NBR		
		JA272  (x2) ⊙ JE231 (x2) Eng.NC7001→	JM448  JM447 			 NA422  50.8x69.9x12.7mm, NBR		 AE540  BE880  BE890
		JA793  JA272  (x2) ⊙ JE231 (x2)	JM448  JM447 	HC425 	HR299 	 NA422  50.8x69.9x12.7mm, NBR		 BJ020  BT070
		JA689  (x12) ⊙ JE231 (x4)	JM537  JM536 	JH485  JH501 	HR299  (x2)	 NB584  54x73x12.4mm, NBR (50-319429-00)		 JA272  JA689  JA793  JC241  JD144  JE231
								 JM447
		JC241  (31-029706-00) HA5011   ⊙ JE231 (x2)	JN927 HM5061 		HR5050 	 NB720  99.3x120x12mm, PTFE (50-319464-00)		 JM448
		JC241  (31-029706-00) HA5010   [173] (24-29707-00/0) HA5011  	JN539 HL702 		HR299  (x2)	 NB720  99.3x120x12mm, PTFE (50-319464-00)		 JM536



KW/PS



XJ 6 3.6L				10/86 → 08/89	14	BT070 (Fibre) (30-029543-00)	DT070 ■	
AJ 6 (3.6, 156KW)	3590	6		Injection	156/212			
9DPANA	3590	6	91.00		145- 156/ 197- 212			
XJ 6 4.0L				09/89 → 11/94	15	BT070 (Fibre) (30-029543-00)	DT070 ■ → Eng.179540 DT071 ■ (21-29543-20/0) Eng.179541 →	
9EPCNA	3980	6	91.00	DOHC	163/222			
XJ 6 4.2L				01/71 → 12/78	16	BJ020 (Fibre)	DJ022 ■ → 1974 DJ023 ■ 1974 →	EH690
XK (4.2)	4235	6	92.07		124/168			
XJ 8 3.2L				07/97 → 05/03	17	AC5270 (Fibre) ☒ (30-029470-00) → 03/00 AC5260 (Fibre) ☒ (30-029469-00) → 03/00 AC5500 (MLS) ☒ (30-029611-00) 04/00 → AC5510 (MLS) ☒ (30-029610-00) 04/00 →	CC5261 (21-29470-21/0) → 03/00	
AJ27 (3.2)	3252	8	86.00		174/237			
XJ 8 4.0L				07/97 → 05/03	18	AC5270 (Fibre) ☒ (30-029470-00) → 03/00 AC5260 (Fibre) ☒ (30-029469-00) → 03/00 AC5500 (MLS) ☒ (30-029611-00) 04/00 → AC5510 (MLS) ☒ (30-029610-00) 04/00 →	CC5261 (21-29470-21/0) → 03/00	
BC	3996	8	86.00	DOHC, V8	209/284			
XJ 8 4.2L				05/03 →	19	AC5500 (MLS) ☒ (30-029611-00) AC5510 (MLS) ☒ (30-029610-00)		
AJ34 (4.2)	4196	8	86.00		219/298			
XJ 12 5.3L				01/71 → 12/81	20		CH831 ■ → 05/75 CH832 ■ 06/75 →	EH831
V 12	5343	12	90.00	SOHC, V12	211/287			
XJ 12 5.3L				01/81 → 12/92	21	BE890 (Fibre) ☒ BE880 (Fibre) ☒	DE880 ■	EH831
V12HE	5343	12	90.00	SOHC, V12	197/268			
XJ R 3.6L				01/88 → 12/89	22	BT070 (Fibre) (30-029543-00)	DT070 ■ → Eng.116000 DT071 ■ (21-29543-20/0) Eng.116001 →	

		JC241 (31-029706-00) HA5010 (24-29707-00/0) JE231 (x2)	JN539 HL702		HR299 (x2)	NB720 99.3x120x12mm, PTFE (50-319464-00)	
		JC241 (x2) (31-029706-00) HA5010 ^[173] (24-29707-00/0) HA5011 Germany JE231 (x2)	JN539 HL702		HR299 (x2)	NB720 99.3x120x12mm, PTFE (50-319464-00)	
		JA793 JA272 (x2) JE231 (x2)	JN180 (x2) 1974→ JM448 →1974 JM447 →1974	HC425	HR299	NA422 50.8x69.9x12.7mm, NBR	
		JA689 (x12) JE231 (x4)	JM537 JM536	JH485 JH501	HR299 (x2)	NB584 54x73x12.4mm, NBR (50-319429-00)	
		JD144 (x12) JA689 (x12) JE231 (x4)	JM537 JM536	JH485 JH501	HR299 (x2)	NB584 54x73x12.4mm, NBR (50-319429-00)	
		JC241 (31-029706-00) HA5010 ^[173] (24-29707-00/0) HA5011 Germany	JN539 HL702		HR299 (x2)	NB720 99.3x120x12mm, PTFE (50-319464-00)	

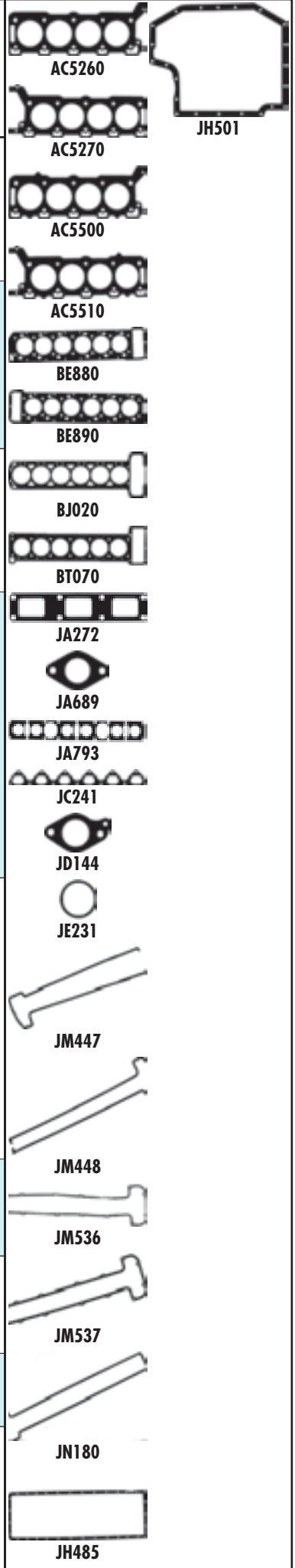









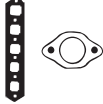

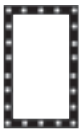

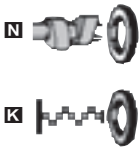























































































KW/PS



XJ R 4.0L		09/89 → 09/94			23	BT070 (Fibre) (30-029543-00)	DT070 ■ → Eng.179540 DT071 ■ (21-29543-20/0) Eng.179541 →
AJ 6	3980	6	91.00	DOHC			
XJ R 4.0L		07/97 → 05/03			24	AC5270 (Fibre) ☒ (30-029470-00) → 03/00 AC5260 (Fibre) ☒ (30-029469-00) → 03/00 AC5500 (MLS) ☒ (30-029611-00) 04/00 → AC5510 (MLS) ☒ (30-029610-00) 04/00 →	CC5262 (21-29470-22/0) → 03/00 CC5502 (21-29611-22/0) 04/00 →
DC	3996	8	86.00	DOHC, V8	267/363		
XJ R 4.0L Super Charged		11/94 → 07/97			25	BT070 (Fibre) (30-029543-00)	DT072 ■ (21-29543-21/0)
9KPDRB	3980	6	86.00		235/320		
XJ R 4.2L		05/03 →			26	AC5500 (MLS) ☒ (30-029611-00) AC5510 (MLS) ☒ (30-029610-00)	
AJ34 (4.2SC)	4196	8	86.00		291/396		
XJ R S 5.3L		01/88 → 09/89			27	BE890 (Fibre) ☒ BE880 (Fibre) ☒	DE880 ■ EH831
V12HE	5343	12	90.00	SOHC, V12	197/268		
XJ S Convertible 3.6L		08/87 → 05/91			28	BT070 (Fibre) (30-029543-00)	DT070 ■
XJ S Coupe 3.6L		08/87 → 12/89					
AJ 6 (3.6, 156KW)	3590	6		Injection	156/212		
XJ S 4.0L		05/95 →			29	BT070 (Fibre) (30-029543-00)	DT072 ■ (21-29543-21/0)
AJ 16 (4.0)	3980	6	91.00	DOHC	177/240		
XJ S 4.0L		05/91 → 09/94			30	BT070 (Fibre) (30-029543-00)	DT070 ■ → Eng.179540 DT071 ■ (21-29543-20/0) Eng.179541 →
XJ S Convertible 4.0L		05/91 → 09/94					
XJ S Coupe 4.0L		05/91 → 09/94					
9EPCNA	3980	6	91.00	DOHC	163/222		
AJ 6	3980	6	91.00	DOHC			
XJ S 5.3L		01/71 → 12/81			31		CH831 ■ → 05/75 CH832 ■ 06/75 → EH831
V 12	5343	12	90.00	SOHC, V12	211/287		
XJ S 5.3L		01/81 → 12/92			32	BE890 (Fibre) ☒ BE880 (Fibre) ☒	DE880 ■ EH831
V12HE	5343	12	90.00	SOHC, V12	197/268		











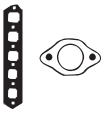

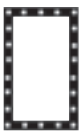
	 						 AC5260  AC5270  AC5500  AC5510  BE880  BE890  BT070  JA689  JC241  JD144  JE231  JM536  JM537  JN927  JH485  JH501
	JC241  (x2) (31-029706-00) HA5010   [173] (24-29707-00/0) HA5011    Germany  JE231 (x2)	JN539 HL702 		HR299  (x2)	 NB720  99.3x120x12mm, PTFE (50-319464-00)		
	JC241  (x2) (31-029706-00) HA5011    JE231 (x2)	JN927 HM5061 		HR5050 	 NB720  99.3x120x12mm, PTFE (50-319464-00)		
	JD144  (x12) JA689  (x12)  JE231 (x4)	JM537  JM536 	JH485  JH501 	HR299  (x2)	 NB584  54x73x12.4mm, NBR (50-319429-00)		
	JC241  (x2) (31-029706-00) HA5010    [173] (24-29707-00/0)  JE231 (x2)	JN539 HL702 		HR299  (x2)	 NB720  99.3x120x12mm, PTFE (50-319464-00)		
	JC241  (x2) (31-029706-00) HA5011    JE231 (x2)	JN927 HM5061 		HR5050 	 NB720  99.3x120x12mm, PTFE (50-319464-00)		
	JC241  (x2) (31-029706-00) HA5010    [173] (24-29707-00/0) HA5011   Germany  JE231 (x2)	JN539 HL702 		HR299  (x2)	 NB720  99.3x120x12mm, PTFE (50-319464-00)		
	JA689  (x12)  JE231 (x4)	JM537  JM536 	JH485  JH501 	HR299  (x2)	 NB584  54x73x12.4mm, NBR (50-319429-00)		
	JD144  (x12) JA689  (x12)  JE231 (x4)	JM537  JM536 	JH485  JH501 	HR299  (x2)	 NB584  54x73x12.4mm, NBR (50-319429-00)		



KW/PS



XK 8 Convertible 4.0L		03/96 →		33		AC5270 (Fibre)		CC5261	
XK 8 Coupe 4.0L		03/96 →				[30-029470-00]		[21-29470-21/0]	
CC/CE	3996	8	86.00	V8	209/284	→03/00		07/97 →03/00	
						AC5260 (Fibre)			
						[30-029469-00]			
						→03/00			
						AC5500 (MLS)			
						[30-029611-00]			
						04/00 →			
						AC5510 (MLS)			
						[30-029610-00]			
						04/00 →			
XK 8 Convertible 4.0L		02/98 →		34		AC5270 (Fibre)		CC5262	
XK 8 Coupe 4.0L		02/98 →				[30-029470-00]		[21-29470-22/0]	
EC	3996	8	86.00	V8	267/363	→03/00		→03/00	
						AC5260 (Fibre)		CC5502	
						[30-029469-00]		[21-29611-22/0]	
						→03/00		04/00 →	
						AC5500 (MLS)			
						[30-029611-00]			
						04/00 →			
						AC5510 (MLS)			
						[30-029610-00]			
						04/00 →			
XK 8 Convertible 4.2L		08/02 →		35		AC5500 (MLS)			
XK 8 Coupe 4.2L		08/02 →				[30-029611-00]			
AJ34 (4.2)	4196	8	86.00		219/298	AC5510 (MLS)			
AJ34 (4.2SC)	4196	8	86.00		291/396	[30-029610-00]			
XK R Convertible 4.2L		08/02 →		36		AC5500 (MLS)			
XK R Coupe 4.2L		08/02 →				[30-029611-00]			
AJ34 (4.2)	4196	8	86.00		219/298	AC5510 (MLS)			
AJ34 (4.2SC)	4196	8	86.00		291/396	[30-029610-00]			
X-Type 3.0L V6		06/01 →		37		AC5400 (MLS)			
AJ67 (3.0)	2967	6	89.00		169/230	[30-029499-00]			
						AC5390 (MLS)			
						[30-029498-00]			

					 		 AC5260  AC5270  AC5390  AC5400  AC5500  AC5510



CC



9



CC



9

242	Diesel	3960	6	98.40	21
242	Diesel	3960	6	98.40	34
242	Diesel	3960	6	98.40	8
425 CLIRS/X	Diesel	2499	4	92.00	15
425 CLIRS/X	Diesel	2499	4	92.00	6
829	Petrol	1995	4	88.00	13
EPE	Petrol	2464	4	98.40	3
EPE	Petrol	2464	4	98.40	30
EPE	Petrol	2464	4	98.40	4
ERH	Petrol	3964	6	98.50	10
ERH	Petrol	3964	6	98.50	22
ERH	Petrol	3964	6	98.50	33
EVA	Petrol	4701	8	93.00	25
EVA	Petrol	4701	8	93.00	26
EVC	Petrol	4701	8	93.00	25
HR 924	Diesel	2500	4	92.00	16
HR 924	Diesel	2500	4	92.00	7
HR 924 HS	Diesel	2500	4	92.00	16
HR 924 HS	Diesel	2500	4	92.00	7
HX	Petrol	2469	4		3
J5R	Petrol	1995	4	88.00	28
J5R-800	Petrol	1995	4	88.00	11
J6R	Petrol	1995	4	88.00	13
J8S	Diesel	2068	4	86.00	1
J8S-800	Diesel	2068	4	86.00	12
M51	Diesel	2499	4		14
M51	Diesel	2499	4		5
M52	Diesel	2499	4		14
M52	Diesel	2499	4		5
MX	Petrol	3964	6		10
MX	Petrol	3964	6		23
P00	Petrol	2464	4		31
P00 (150)	Petrol	2464	4	98.40	2
S01	Petrol	3960	6	98.45	24
S01	Petrol	3960	6	98.45	32
Y01	Petrol	5216	8		27
ZEJ	Petrol	1995	4	88.00	13



KWPS

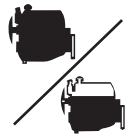

Cherokee 2.1L TD Diesel				10/84 → 03/92		1	BH080 (Fibre), 1.60mm, 1 Hole (30-024772-10) → 0.96mm BG900 (Fibre), 1.70mm (30-024773-10) → 0.96 → 1.04mm BH090 (Fibre), 1.80mm, 2 Holes (30-024774-10) → 1.04mm →	DH080▲ (21-24775-21/0)	EG176 [36] (22-24777-01/0) GH080▲ [36]
J8S	2068	4	86.00	Injection		59-64/ 80-87			
Cherokee 2.5L				01/83 →		2	AC5600 (Fibre) (30-029615-00)	CC5600■ (21-29615-20/0) → 12/91 CC5601■ (21-29615-21/0) 01/92 → 12/93 CC5602■ (21-29615-22/0) 01/94 → 12/96 CC5603■ (21-29615-23/0) 01/97 →	
P00 (150)	2464	4	98.40			87/118			
Cherokee 2.5L i				12/91 →		3	AC5600 (Fibre) (30-029615-00)	CC5601■ (21-29615-21/0) → 12/93 CC5602■ (21-29615-22/0) 01/94 → 12/96 CC5603■ (21-29615-23/0) 01/97 →	
EPE	2464	4	98.40	OHV		87-90/ 118- 122			
HX	2469	4		Injection		90/122			
Cherokee 2.5L i				11/96 →		4	AC5600 (Fibre) (30-029615-00)	CC5603■ (21-29615-23/0)	
EPE	2464	4	98.40	OHV		87-90/ 118- 122			
Cherokee 2.5L TD Diesel				01/88 →		5	AY400 (MLS), 1.42mm, 0 Notches (30-028472-00) AY410 (MLS), 1.52mm, 2 Notches (30-028473-00) AY420 (MLS), 1.62mm, 1 Notch (30-028474-00)	DK570▲ [7] (21-25850-21/0)	GK572▲ [8] (20-25850-01/0)
M52	2499	4				85/115			
M51	2499	4				85-89/ 115- 121			
Cherokee 2.5L TD Diesel				01/95 → 12/96		6	AY400 (MLS), 1.42mm, 0 Notches (30-028472-00) AY410 (MLS), 1.52mm, 2 Notches (30-028473-00) AY420 (MLS), 1.62mm, 1 Notch (30-028474-00)	DK573▲ [105] (21-28472-20/0)	GK573▲ [8] (20-28472-00/0)
425 CLIRS/X	2499	4	92.00	Turbo		85/116			
Cherokee 2.5L TD Limited Diesel				01/95 →		7	AY400 (MLS), 1.42mm, 0 Notches (30-028472-00) BK570 (Fibre), 1.42mm, 0 Notches (x4) (30-025008-20) AY410 (MLS), 1.52mm, 2 Notches (30-028473-00) BP260 (Fibre), 1.52mm, 2 Notches (x4) (30-025013-20) AY420 (MLS), 1.62mm, 1 Notch (30-028474-00) BK580 (Fibre), 1.62mm, 1 Notch (x4) (30-025007-20)	DK573▲ [105] (21-28472-20/0)	GK573▲ [8] (20-28472-00/0)
HR 924/HR 924 HS	2500	4	92.00	Turbo		85/115			

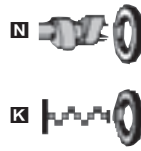
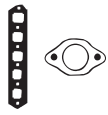

AC5600



AY400, AY410,
AY420



BG900



BH080, BH090



BK570, BP260,
BK580



JC928



JD025



JD245



JD5144

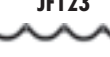

JF123



JN697



JP067



JP068



JJ558

HBS010
(22-51104B)
M12x1.50x247mm (x2)
M12x1.50x148mm (x4)
M12x1.50x134mm (x8)

JD245

JN697

(31-024775-10)

JJ558

(Felt)

● **PB852**

16x24x1.5mm

● **PA349**

(33-102290-10)

22x16x2mm

HR569

24-30667-00/0

NF843 50x68x10mm, FPM/ACM
(50-305667-70)

NF844 90x110x11mm, FPM/ACM

HR351 [37]

NF781 [2]

JD5779

JD5779

NA5133 85x105x11mm, FPM
(24-30727-87/0)

JD5779

HBS108
(22-56003B)
M14x2.0x137mm (x10)
M12x1.75x115mm (x4)
M12x1.75x79.5mm (x4)

JD5144

(31-028425-00)

HBS108
(22-56003B)
M14x2.0x137mm (x10)
M12x1.75x115mm (x4)
M12x1.75x79.5mm (x4)

JD5144

(31-028425-00)

HBS108
(22-56003B)
M14x2.0x137mm (x10)
M12x1.75x115mm (x4)
M12x1.75x79.5mm (x4)

JC928

(31-025852-10)

JD025

(31-025849-10)

JF123

(31-027523-00)

JP067

(31-025850-10)

JP068 [9]

(31-029626-00)



KW/PS



Cherokee 4.0L Diesel				01/87 →	8	AC5610 (Fibre) (30-029593-00) →2004	CC5610■ →1990 CC5611■ 1991→1993 CC5612■ 1994→1995 CC5613■ 1996→	
242	3960	6	98.40					
Cherokee 4.0L i				07/98 →	9	AC5610 (Fibre) (30-029593-00) →2004	CC5612■	
	3960	6			127/173 135/184			
	3960	6						
Cherokee 4.0L i				01/88 →	10	AC5610 (Fibre) (30-029593-00) →2004	CC5612■ →1995 CC5613■ 1996→	
MX	3964	6		Injection	135- 136/ 184 185			
ERH	3964	6	98.50	OHV	131/178			
CJ5 - CJ8 2.0L				01/83 →12/87	11	BG170 (Fibre), 1.20mm (30-027064-10)	DG170 →12/86 DG173 (21-27064-20/0)	EG176 [36] (22-24777-01/0)
J5R-800	1995	4	88.00	SOHC	61-63/ 85-86			
CJ5 - CJ8 2.1L D Diesel				01/83 →12/87	12	BH080 (Fibre), 1.60mm, 1 Hole (30-024772-10) →0.96mm BG900 (Fibre), 1.70mm (30-024773-10) →0.96 →1.04mm BH090 (Fibre), 1.80mm, 2 Holes (30-024774-10) →1.04mm →	DH080▲ (21-24775-21/0)	EG176 [36] (22-24777-01/0) GH080▲ [36]
J8S-800	2068	4	86.00	Direct Injection, SOHC	44/60			
CJ7 2.0L				01/85 →	13	BG170 (Fibre), 1.20mm (30-027064-10)	DG173 (21-27064-20/0)	EG176 [36] (22-24777-01/0)
CJ7 2.0L Laredo				01/85 →				
829/J6R/ZEJ	1995	4	88.00	Injection				
Grand Cherokee 2.5L TD Diesel				10/95 →04/99	14	BZ110 (Fibre), 1.68mm, 2 Holes 30-027395-20 BZ120 (Fibre), 1.87mm, 3 Holes 30-027396-20		EY280 22-27096-02/0
M52	2499	4			85/115			
M51	2499	4			85-89/ 115- 121			
Grand Cherokee 2.5L TD Diesel				01/97 →12/01	15	AY400 (MLS), 1.42mm, 0 Notches (30-028472-00) AY410 (MLS), 1.52mm, 2 Notches (30-028473-00) AY420 (MLS), 1.62mm, 1 Notch (30-028474-00)	DK573▲ [105] (21-28472-20/0)	GK573▲ [8] (20-28472-00/0)
425 CLIRS/X	2499	4	92.00	Turbo	85/116			

							AC5610 AY400, AY410, AY420 BG170 BG900 BH080, BH090 BZ110, BZ120 JB954 JD245 JD274 JD275 JD276 JD5144 JN292 JN697 JN955 JJ536 JJ558 KK5484 [14] JR5044 [11]
		JM5286					
HBS438 (22-29023B)	JD5780 →1998	JM5286					
HBS116⊗ (22-51006B) M12x1.50x243mm (x10)	JB954⊗	JN292 (50-024771-00)	JJ558 (Felt) ●PB852 16x24x1.5mm ●PA349 (33-102290-10) 22x16x2mm	HR569⊗ 24-30667-00/0	NF687⊗ 35x47x7mm, ACM NF843⊗ 50x68x10mm, FPM/ACM (50-305667-70) NF844⊗ 90x110x11mm, FPM/ACM	HL5014 [245]⊗ NF849 [15]	
HBS010⊗ ⊗ (22-51104B) M12x1.50x247mm (x2) M12x1.50x148mm (x4) M12x1.50x134mm (x8)	JD245	JN697 (31-024775-10)	JJ558 (Felt) ●PB852 16x24x1.5mm ●PA349 (33-102290-10) 22x16x2mm	HR569⊗ 24-30667-00/0	NF843⊗ 50x68x10mm, FPM/ACM (50-305667-70) NF844⊗ 90x110x11mm, FPM/ACM	HR351 [37]⊗ NF781 [2]⊗	
HBS116⊗ (22-51006B) M12x1.50x243mm (x10)	JB954⊗	JN292 (50-024771-00)	JJ558 (Felt) ●PB852 16x24x1.5mm ●PA349 (33-102290-10) 22x16x2mm	HR569⊗ 24-30667-00/0	NF687⊗ 35x47x7mm, ACM NF843⊗ 50x68x10mm, FPM/ACM (50-305667-70) NF844⊗ 90x110x11mm, FPM/ACM	HL5014 [245]⊗ NF849 [15]	
HBS280⊗ (22-29017B) M11x1.50x145mm (x10)	JD274⊗ (x6) 31-027183-00 JD275⊗ (x4) 31-027180-00 JD276⊗ [274] 31-027181-00	JN955 50-027179-00	JJ536 (31-027096-20)		NF637⊗ 48x65x10mm, FPM (50-306222-50) NB431⊗ 90x110x12mm, FPM (50-306091-50)	KK5484 [14] JR5044 [11]	
HBS108⊗ (22-56003B) M14x2.0x137mm (x10) M12x1.75x115mm (x4) M12x1.75x79.5mm (x4)	JD5144 (31-028425-00)						



KW/PS



Model	CC	Cyl	Power (kW/PS)	Year Range	Code	Notes	Accessories
Grand Cherokee 2.5L TD Limited Diesel HR 924/HR 924 HS	2500	4	92.00	01/95 →	16 85/115	AY400 (MLS), 1.42mm, 0 Notches (30-028472-00) BK570 (Fibre), 1.42mm, 0 Notches (x4) (30-025008-20) AY410 (MLS), 1.52mm, 2 Notches (30-028473-00) BP260 (Fibre), 1.52mm, 2 Notches (x4) (30-025013-20) AY420 (MLS), 1.62mm, 1 Notch (30-028474-00) BK580 (Fibre), 1.62mm, 1 Notch (x4) (30-025007-20)	DK573▲ [105] (21-28472-20/0) GK573▲ [8] (20-28472-00/0)
Grand Cherokee 2.7L CRD Diesel	2685	5		10/01 →	17 120/163	AD5720 (MLS), 1.20mm 30-029696-00	CD5720 ☒ 21-29696-00/0
Grand Cherokee 3.0L CRD Mk III Diesel	2987	6		06/05 →	18 160/218		
Grand Cherokee 3.1L TD Diesel	3125	5		04/99 →	19 103/140	BZ780 (30-028661-00) BZ630 (MLS), 1.33mm (30-028536-00) BZ640 (MLS), 1.43mm, 2 Notches (30-028537-00) BZ650 (MLS), 1.53mm, 1 Notch (30-028538-00)	DZ630▲ EZ630
Grand Cherokee 4.0L	3960	6		04/99 →	20 140/190	AC5610 (Fibre) (30-029593-00) →2004	
Grand Cherokee 4.0L Diesel 242	3960	6	98.40	01/87 →	21	AC5610 (Fibre) (30-029593-00) →2004	CC5610 ■ →1990 CC5611 ■ 1991→1993 CC5612 ■ 1994→1995 CC5613 ■ 1996→1998
Grand Cherokee 4.0L i ERH	3964	6	98.50	09/91 →04/99	22 131/178	AC5610 (Fibre) (30-029593-00) →2004	CC5611 ■ →1993 CC5612 ■ 1994→1995 CC5613 ■ 1996→
Grand Cherokee 4.0L i MX	3964	6		09/91 →04/99	23 135-136/184-185	AC5610 (Fibre) (30-029593-00) →2004	CC5611 ■ →1993 CC5612 ■ 1994→1995 CC5613 ■ 1996→1998
Grand Cherokee 4.0L i S01	3960	6	98.45	10/95 →04/99	24 130/177	AC5610 (Fibre) (30-029593-00) →2004	CC5613 ■ →1998

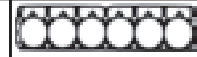
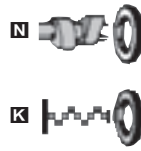
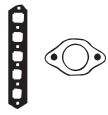

AC5610



AD5720



AY400, AY410,
AY420



BK570, BP260,
BK580



BZ630, BZ640,
BZ650



JC928



JD025



JD5378



JF123



JP067



JP068

HBS108Ⓢ
(22-56003B)
M14x2.0x137mm (x10)
M12x1.75x115mm (x4)
M12x1.75x79.5mm (x4)

JC928■
(31-025852-10)
JD025■
(31-025849-10)
Ⓢ**JF123**
(31-027523-00)

JP067
(31-025850-10)
JP068 [9]
(31-029626-00)

HBS293Ⓢ
(22-26010B)
M12x1.75x102mm (x12)

JD5378■ (x5)
(50-029975-00)
JD5797■
(31-030176-00)
JD5798■
31-030177-00

JM7028
(50-030203-00)
HM5274■
24-30181-00/0

■ **NA5131**■ 45x67x8mm, PTFE
(50-319436-00)
■ **NA5074**■ [3] 93x133.5x15.5mm,
PTFE
(50-319396-00)

HBS474Ⓢ
(22-26025B)
M12x1.75x205mm (x16)

HBS438
(22-29023B)

JM5286

HBS438
(22-29023B)

JD5780
→1998

JM5286

HBS438
(22-29023B)

JD5780
→1998

JM5286

JD5780
→1998

JM5286



KWPS



Grand Cherokee 4. 7V8						04/99 → 08/00	25	AD5760 (MLS)	CD5760■ (21-29740-20/0)	
Grand Cherokee 4.7L V8						08/00 →				
EVA	4701	8				162/220				
	4701	8	93.00	V8		167- 175/ 227- 238				
EVC	4701	8	93.00	DOHC, V8		190/258				
Grand Cherokee 4.7L V8 Mk III						06/05 →	26			
EVA	4701	8	93.00	V8		167- 175/ 227- 238				
Grand Cherokee 5.2L (Z) Mk I						10/95 → 04/99	27	AG9690 Soft Material Gasket	CG9690	EG9690
Y01	5216	8				156/212				
Renegade 2.0L						05/83 → 12/86	28	BG170 (Fibre), 1.20mm (30-027064-10)	DG173 (21-27064-20/0)	EG176 [36] (22-24777-01/0)
J5R	1995	4	88.00							
Wrangler 2.5L						01/88 → 12/91	29	AC5600 (Fibre) (30-029615-00)	CC5600■ (21-29615-20/0)	
	2464	4				76/103				
Wrangler 2.5L						12/91 → 08/96	30	AC5600 (Fibre) (30-029615-00)	CC5601■ (21-29615-21/0) → 12/93	
EPE	2464	4	98.40	OHV		87-90/ 118- 122			CC5602■ (21-29615-22/0) 01/94 →	
Wrangler 2.5L						08/96 →	31	AC5600 (Fibre) (30-029615-00)	CC5603■ (21-29615-23/0)	
PO0	2464	4				87/118				
Wrangler 4.0L						08/96 →	32	AC5610 (Fibre) (30-029593-00) → 2004	CC5613■ → 1998	
S01	3960	6				124/169 130/177				
	3960	6	98.45							
Wrangler 4.0L						12/91 → 08/96	33	AC5610 (Fibre) (30-029593-00) → 2004	CC5611■ → 1993	
ERH	3964	6	98.50	OHV		131/178			CC5612■ 1994 →	
									CC5613■ 1996 →	
Wrangler 4.0L Diesel						01/87 →	34	AC5610 (Fibre) (30-029593-00) → 2004	CC5610■ → 1990	
242	3960	6	98.40						CC5611■ 1991 → 1993	
									CC5612■ 1994 → 1995	
									CC5613■ 1996 →	

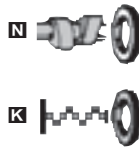
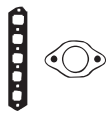

AC5600

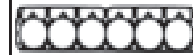

AC5610



BG170



HA5016



JB954



JN292



JJ558

HBS439 (22-29024B)	HA5015 (24-29740-01/0) HA5016 (24-29740-02/0)	HM5064 (24-29740-00/0)		HR5077	NA5173 (50-319471-00)	
HBS439 (22-29024B)						
	JD5876 (Fibre) JD5877 (Fibre)	JM7050 (Steel Elastomer)	JH5106 (Rubber/Metal)			
HBS116 (22-51006B) M12x1.50x243mm (x10)	JB954	JN292 (50-024771-00)	JJ558 (Felt) - PB852 16x24x1.5mm - PA349 (33-102290-10) 22x16x2mm	HR569 24-30667-00/0	NF843 50x68x10mm, FPM/ACM (50-305667-70) NF844 90x110x11mm, FPM/ACM	
	JD5779					
	JD5779					
	JD5779					
HBS438 (22-29023B)						
HBS438 (22-29023B)	JD5780 →1998	JM5286				



CC



9



CC



9

B1	Petrol	1324	4	68.00	27
B3	Petrol	1324	4	71.00	29
B3	Petrol	1324	4	71.00	30
B5	Petrol	1498	4	78.00	20
B5	Petrol	1498	4	78.00	39
B6	Petrol	1597	4	78.00	40
D4BH	Diesel	2476	4	91.10	25
D4CB	Diesel	2497	4	91.00	47
D4EA	Diesel	1991	4	83.00	16
D4EA	Diesel	1991	4	83.00	5
D4EA	Diesel	1991	4	83.00	52
D4EA	Diesel	1991	4	83.00	6
D4EA-F	Diesel	1991	4	83.00	49
D4EA-V	Diesel	1991	4	83.00	49
D4FA	Diesel	1493	4	75.00	14
D4FA	Diesel	1493	4	75.00	37
FE	Petrol	1998	4	86.00	54
FE (16 V)	Petrol	1998	4	86.00	18
FE (16 V)	Petrol	1998	4	86.00	33
FE (16 V)	Petrol	1998	4	86.00	53
G4GC	Petrol	1975	4	82.00	13
G4GC	Petrol	1975	4	82.00	15
G4GC	Petrol	1975	4	82.00	32
G4GC	Petrol	1975	4	82.00	4
G4GC	Petrol	1975	4	82.00	51
G4HE	Petrol	999	4	66.00	23
G4HG	Petrol	1086	4	67.00	24
J3	Diesel	2902	4	97.10	11
OK24N	Petrol	1793	4	81.00	3
OK24N	Petrol	1793	4	81.00	41
OK24N	Petrol	1793	4	81.00	46
OK26Y	Petrol	1793	4	81.00	3
OK26Y	Petrol	1793	4	81.00	41
OK26Y	Petrol	1793	4	81.00	46
OK280	Petrol	1498	4	78.00	42
R2	Diesel	2184	4	86.00	1
RF	Diesel	1998	4	86.00	34
RF	Diesel	1998	4	86.00	55
T8	Petrol	1793	4	81.00	17

KIA



KWPS



Besta Van 2.2L D Diesel						02/96 →	1	BN620 (Fibre)	DN621	GN621
R2	2184	4	86.00	Indirect Injection, SOHC	48/65		BS460 (Graphite) (30-025236-20)	(21-25236-21/0)	(20-25236-01/0)	
Carens 1.6L						07/02 →	2	AG8260 (MLS)	CG8260	FG8260
	1594	4			77/105					
Carens 1.8L						11/00 → 07/02	3	AG9190 (MLS)	CG9190	EG9190
OK24N	1793	4		DOHC	93/126					
OK26Y	1793	4	81.00	Injection, DOHC	81/110					
	1793	4	81.00		81/110					
Carens 2.0L CVVT Mk II						08/04 →	4			
G4GC	1975	4	82.00	DOHC	104/141					
Carens 2.0L CRDi Mk II Diesel						11/05 →	5	AG7920 (MLS), 1.10mm	CG7920▲	
Carens 2.0L CRDi Mk III Diesel						09/06 →		AG7930 (MLS), 1.20mm		
D4EA	1991	4	83.00	Direct Injection, SOHC	83/113		AG7940 (MLS), 1.30mm			
Carens 2.0L CRDi Diesel						07/02 →	6	AG7920 (MLS), 1.10mm	CG7920▲	
D4EA	1991	4	83.00	Direct Injection, SOHC	83/113		AG7930 (MLS), 1.20mm			
							AG7940 (MLS), 1.30mm			
Carnival 2.5L V6						08/99 → 10/01	7	AB5080 (Steel Elastomer) (30-029276-00)	CB5080 (21-29276-20/0)	
	2497	6			121/165					
Carnival 2.5L V6						10/01 →	8	AB5080 (Steel Elastomer) (30-029276-00) →03/02	CB5080 (21-29276-20/0) →03/02	
	2497	6			110/150					
Carnival 2.9L CRDi Diesel						10/01 →	9			
	2902	4			106/144					
Carnival 2.9L TD Diesel						08/99 → 10/01	10	AG8140 (MLS) →02/00	CG8140 →02/00	FG8140 →02/00
	2903	4			93/126					
Carnival 2.9L CRDi Mk III Diesel						06/06 →	11	AG9910 (MLS)	CG9910	
J3	2902	4	97.10	Direct Injection, DOHC						
Carnival 2.9L TD Mk II Diesel						10/01 →	12			
	2903	4			93/126					
CEE'D 2.0L						12/06 →	13			
G4GC	1975	4	82.00	DOHC	104/141					
Cerato 1.5L CRDi Diesel						07/05 →	14			
D4FA	1493	4	75.00	Direct Injection, DOHC	75/102					
Cerato 2.0L						04/04 →	15			
G4GC	1975	4	82.00	DOHC	104/141					
Cerato 2.0L CRDi Diesel						04/04 →	16	AG7920 (MLS), 1.10mm	CG7920▲	
D4EA	1991	4	83.00	Direct Injection, SOHC	83/113		AG7930 (MLS), 1.20mm			
							AG7940 (MLS), 1.30mm			
Clarus 1.8Li 16V						07/96 →	17	AG8200 (MLS) TED	CG8200 TED	FG8200 TED
T8	1793	4	81.00	Injection, DOHC	85/116					

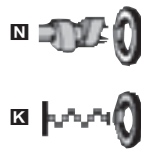
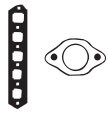

AB5080



BN620



BS460



JC477



JC598

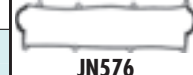

JN576



JJ268

HBS211 ☉ (22-75001B) M12x1.50x113mm (x10)	JC598 ■ JC477 ■ ☉JE102	JN576 (50-026765-00)	JJ268	PA659 (x8)	☒ NJ324 ■ 34x48x7mm, ACM ☒ NJ325 ■ 90x110x9mm, MVQ	
		JM5320	HC5009 ■		☒ NK158 ■ 37x50.5x7mm, ACM	
		JM7038 (Rubber)				
HBS478 (22-76025B)						
HBS381 ☉ (22-76009B) M12x1.50x183mm (x10)		HM5251 ■				
HBS382 ☉ (22-76010B) M12x1.50x183mm (x10)		HM5251 ■				
HBS423 (22-89009B) M9x1.25x200mm (x16)					☒ NC065 ■ (x2) 30x40x7mm, FPM (50-306142-00) ☒ NB998 ■ (x4) 30x40x7mm, FPM (50-319402-00) ☒ NA5083 ■ 32.5x45x7.7mm, FPM (50-319423-00) ☒ LK5000 ■ [3] 89x116x10.2mm, FPM (50-319424-00)	
HBS423 (22-89009B) M9x1.25x200mm (x16)					☒ NC065 ■ (x2) 30x40x7mm, FPM (50-306142-00) ☒ NB998 ■ (x4) 30x40x7mm, FPM (50-319402-00) ☒ NA5083 ■ 32.5x45x7.7mm, FPM (50-319423-00) ☒ LK5000 ■ [3] 89x116x10.2mm, FPM (50-319424-00)	
HBS379 ☉ (22-76008B) M12x1.25x131mm (x10) M12x1.25x92mm (x8)		JM5310				
HBS379 ☉ (22-76008B) M12x1.25x131mm (x10) M12x1.25x92mm (x8)		JM5310				
HBS379 ☉ (22-76008B) M12x1.25x131mm (x10) M12x1.25x92mm (x8)						
HBS478 (22-76025B)						
HBS483 (22-76026B)						
HBS478 (22-76025B)						
HBS382 ☉ (22-76010B) M12x1.50x183mm (x10)		HM5251 ■				
		JM7038 (Rubber)				

KIA



KW/PS



Clarus 2.0Li 16V	07/96 →				18	BR850 (Graphite) (30-028000-00)	DR850 (21-28000-20/0)	GR850 (20-28000-00/0)
FE (16 V)	1998	4	86.00	DOHC	94/98/ 128-133			
K2700 2.7L D Diesel	10/99 →				19	AE5470 (MLS)	CE5470 ■	FE5470
	2665	4			59/80			
Leo 1.5L 8V	01/96 →				20	BP600 (Graphite) (30-027997-00)	DP602 (21-27997-22/0)	GP602 (20-27997-02/0)
B5	1498	4	78.00	Injection	59/80			
Magentis 2.0L	05/01 →				21	AF5430 (MLS) G4JP	CF5430 G4JP	
	1997	4			100/136			
Magentis 2.5L V6	05/01 →				22			
	2493	6			124/169			
Picanto 1.0L	09/05 →				23	AG9900 (MLS)	CG9900	
G4HE	999	4	66.00	Injection	45/61			
Picanto 1.1L	04/04 →				24	AG9900 (MLS)	CG9900	FG8060
G4HG	1086	4	67.00	SOHC	48/65			
Pregio Van 2.5L TCi D Diesel	09/02 →				25	BS130 (Graphite), 1,50mm (30-028225-00)	DS130 (21-28225-20/0)	
D4BH	2476	4	91.10	Indirect Injection, SOHC	69/93			
Pregio Van 2.7L D Diesel	10/97 →				26	AE5470 (MLS)	CE5470 ■	FE5470
	2665	4			60/82			
Pride 1.1L i	01/91 →				27	BR960 (Graphite) (30-028001-00)		
B1	1324	4	68.00	Injection	38/52			
Pride 1.3L	08/99 →				28	BV430 (Graphite)	DV431	
	1324	4			47/64			
Pride 1.3L 16V	01/90 →				29	BR960 (Graphite) (30-028001-00)	DV431	GR963
B3	1324	4	71.00	Injection, SOHC	44-53/ 60-73			
Pride 1.3L 16V	10/96 →				30	BV430 (Graphite)	DV431	GV431
B3	1324	4	71.00	Injection, SOHC	44-53/ 60-73			
Pride 1.3L i	01/90 →				31	BR960 (Graphite) (30-028001-00)		
	1324	4			51/69			
PRO CEE'D 2.0L	02/08 →				32			
G4GC	1975	4	82.00	DOHC	104/141			
Retona 2.0L 16V	05/00 →				33	BR850 (Graphite) (30-028000-00)	DR850 (21-28000-20/0)	GR850 (20-28000-00/0)
FE (16 V)	1998	4	86.00	DOHC	94-98/ 128-133			
Retona 2.0L TD Diesel	06/99 →				34	AG5130 (MLS), 1.5mm	CG5460	
RF	1998	4	86.00	Indirect Injection, SOHC	61/83			
Rio 1.3L	08/00 → 02/05				35	AG7830 (MLS) 09/00 →	CG7830 09/00 →	FG7830 09/00 →
	1343	4			55/75			
	1343	4			60/82			
Rio 1.3L	09/00 → 02/05				36	AG7830 (MLS) B3	CG7830 B3	FG7830 B3
	1343	4			55/75			
Rio 1.5L CRDi Mk II Diesel	03/05 →				37			
D4FA	1493	4	75.00	Direct Injection, DOHC	75/102			
Rio 1.5L	08/00 → 02/05				38	AG8250 (MLS) 09/00 →	CG8250 09/00 →	FG8250 09/00 →
	1493	4			71/97			
	1493	4			72/98			
Sephia 1.5L i 16V	02/96 → 10/97				39	AG7840 (Fibre)	CG7840	FG7840
B5	1498	4	78.00	Injection	59/80			
Sephia 1.6L i	09/93 →				40	BV110 (Fibre)	DV110 (21-28009-20/0)	GV110
B6	1597	4	78.00	SOHC	59/80			

HBS455 <i>(22-76016B)</i> M12x1.25x95.0mm (x10)		JN717 <i>(50-028065-00)</i>	JJ268	PA956 (x16)	<input checked="" type="checkbox"/> NJ324 34x48x7mm, ACM <input checked="" type="checkbox"/> NJ325 90x110x9mm, MVQ			AE5470
	JD5328 ■ JD5327 ■	JM5196 (Rubber)						BP600
	JC974 ■	JN628 <i>(50-028048-00)</i>	JJ354	PA883 (x8)	<input checked="" type="checkbox"/> NJ448 30x44x7mm, NBR <input checked="" type="checkbox"/> NJ448 30x44x7mm, NBR <input checked="" type="checkbox"/> NJ650 83x100x9mm, ACM			BR850
HBS354 ⊕ <i>(22-76006B)</i> M11x1.25x97mm (x10)					<input checked="" type="checkbox"/> NK143 85x103x8mm, FPM			BR960
HBS446								BS130
HBS378 ⊕ <i>(22-76007B)</i> M10x1.25x106.5mm (x10)		JM5306						BV110
HBS378 ⊕ <i>(22-76007B)</i> M10x1.25x106.5mm (x10)		JM5306						BV430
	JD5328 ■ JD5327 ■	JM5196 (Rubber)			<input checked="" type="checkbox"/> NA5197 90x110x9mm, ACM <input checked="" type="checkbox"/> NA5196 53x69.85x11mm, MVQ			JC665
HBS406 <i>(22-75007B)</i>								JC974
HBS406 <i>(22-75007B)</i>			HC5009 ■		<input checked="" type="checkbox"/> NK158 37x50.5x7mm, ACM			JN628
HBS406 <i>(22-75007B)</i>	JD5753 ■ ⊕JE101	JN774		PA956 (x16)	<input checked="" type="checkbox"/> NJ448 30x44x7mm, NBR <input checked="" type="checkbox"/> NK158 37x50.5x7mm, ACM <input checked="" type="checkbox"/> NJ650 83x100x9mm, ACM			JN717
HBS406 <i>(22-75007B)</i>	JD5753 ■ ⊕JE101	JN774		PA956 (x16)	<input checked="" type="checkbox"/> NJ448 30x44x7mm, NBR <input checked="" type="checkbox"/> NK158 37x50.5x7mm, ACM <input checked="" type="checkbox"/> NJ650 83x100x9mm, ACM			JN774
HBS406 <i>(22-75007B)</i>			HC5009 ■		<input checked="" type="checkbox"/> NK158 37x50.5x7mm, ACM			JJ268
HBS478 <i>(22-76025B)</i>								JJ354
HBS455 <i>(22-76016B)</i> M12x1.25x95.0mm (x10)		JN717 <i>(50-028065-00)</i>	JJ268	PA956 (x16)	<input checked="" type="checkbox"/> NJ324 34x48x7mm, ACM <input checked="" type="checkbox"/> NJ325 90x110x9mm, MVQ			
HBS211 ⊕ <i>(22-75001B)</i> M12x1.50x113mm (x10)								
HBS435 ⊕ <i>(22-76012B)</i>		JM5295 09/00 → B3			<input checked="" type="checkbox"/> NK158 37x50.5x7mm, ACM			
HBS435 ⊕ <i>(22-76012B)</i>		JM5295 B3			<input checked="" type="checkbox"/> NK158 37x50.5x7mm, ACM			
HBS483 <i>(22-76026B)</i>								
HBS436 <i>(22-76013B)</i>		JM5320 09/00 →						
	JC974 ■	JM5296 B5	HC5009 ■ JJ354	PA883 (x16)	<input checked="" type="checkbox"/> NJ448 30x44x7mm, NBR <input checked="" type="checkbox"/> NJ448 30x44x7mm, NBR <input checked="" type="checkbox"/> NK158 37x50.5x7mm, ACM <input checked="" type="checkbox"/> NJ650 83x100x9mm, ACM			
HBS406 <i>(22-75007B)</i>	JC665 ■ ⊕JE102	JN774		PA883 (x8)	<input checked="" type="checkbox"/> NJ650 83x100x9mm, ACM			

KIA



KWPS



Sephia 1.8L i 16V						01/95 →	41	AG8200 (MLS)	CG8200	FG8200
OK24N	1793	4	81.00	DOHC	81/110	01/96 →	AG8200 (MLS)	CG8200	FG8200	
OK26Y	1793	4	81.00	Injection, DOHC	81/110	TED	TED	TED	TED	
Shuma 1.5L						03/96 → 12/98	42	AG7840 (Fibre)	CG7840	FG7840
OK280	1498	4	78.00	Injection, SOHC	59/80	09/97 →	AG7840 (Fibre)	CG7840	FG7840	
							→02/01	→02/01	→02/01	
Shuma 1.5L i 16V						10/97 → 10/01	43	AG7840 (Fibre)	CG7840	FG7840
	1498	4			65/88		BP600 (Graphite)	DP602		
							(30-027997-00)	(21-27997-22/0)		
Shuma 1.6L						05/01 → 08/04	44	AG8260 (MLS)	CG8261	
	1594	4			75/101					
Shuma 1.8L						04/03 → 08/04	45	AG8200 (MLS)	CG8200	FG8200
	1793	4			84/114		TED	TED	TED	
Shuma 1.8L i 16V						10/97 → 03/01	46	AG8200 (MLS)	CG8200	FG8200
OK24N	1793	4	81.00	DOHC	81/110		TED	TED	TED	
OK26Y	1793	4	81.00	Injection, DOHC	81/110					
Sorento 2.5L CRDi Diesel						08/02 →	47	AG9870 (MLS), 0,80mm, 0 Notches	CG9870▲	
D4CB	2497	4	91.00	Direct Injection			AG9880 (MLS), 0,85mm, 1 Notch			
							AG9890 (MLS), 0,90mm, 2 Notches			
Sorento 3.5L V6						08/02 →	48	AG7790 (MLS) ☒	CG7780	
	3497	6			143/194	11/02 →	6674	6674	6674	
							AG7780 (MLS) ☒			
							11/02 →			
							6674			
Sportage 2.0L CRDi Diesel						01/06 →	49			
Sportage 2.0L CRDi 4WD Diesel						01/06 →				
D4EA-F	1991	4	83.00	Direct Injection						
D4EA-V	1991	4	83.00	Direct Injection, SOHC						
Sportage 2.0L						10/00 → 08/03	50	BR850 (Graphite)	DR850	
Sportage 2.0L 4WD						10/00 → 08/03		(30-028000-00)	(21-28000-20/0)	
	1998	4			87/118					
Sportage 2.0L 16V						09/04 →	51			
Sportage 2.0L 16V 4WD						09/04 →				
G4GC	1975	4	82.00	DOHC	104/141					
Sportage 2.0L CRDi 4WD Diesel						09/04 →	52	AG7920 (MLS), 1.10mm	CG7920▲	
D4EA	1991	4	83.00	Direct Injection, SOHC	83/113		AG7930 (MLS), 1.20mm			
							AG7940 (MLS), 1.30mm			
Sportage 2.0L i 16V						10/00 → 08/03	53	BR850 (Graphite)	DR850	GR850
Sportage 2.0L i 16V 4WD						04/94 → 08/03		(30-028000-00)	(21-28000-20/0)	(20-28000-00/0)
FE (16 V)	1998	4	86.00	DOHC	94-98/ 128- 133					
Sportage 2.0L i 4WD						04/94 → 08/99	54	BL320 (Fibre)	DL321	GL321
FE	1998	4	86.00	SOHC	70/95		(30-026717-10)			
Sportage 2.0L TD 4WD Diesel						10/97 → 08/03	55	AG5130 (MLS), 1.5mm	CG5460	
RF	1998	4	86.00	Indirect Injection, SOHC	61/83					
Sportage 2.2L D Diesel						01/94 →	56	BN620 (Fibre)	DN621	GN621
							BS460 (Graphite)	(21-25236-21/0)	(20-25236-01/0)	
							(30-025236-20)			

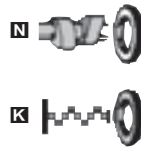
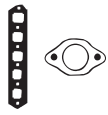

BL320



BN620



BP600



BR850



BS460



JC400



JC401



JC477



JC598



JN533

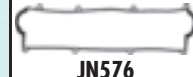

JN576



JN717



JJ268











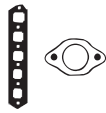

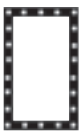

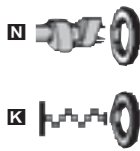









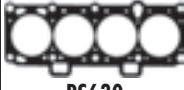
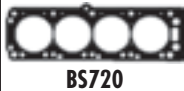





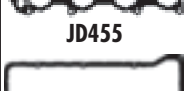



















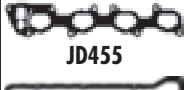



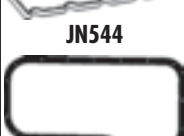

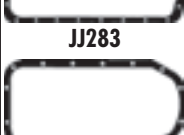

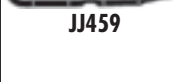



		JM7038 (Rubber)					
HBS406 (22-75007B)		JM5296 09/97→	HC5009E		☒ NK158E 37x50.5x7mm, ACM		
		JM5296 →02/01	HC5009E		☒ NK158E 37x50.5x7mm, ACM		
		JM5320			☒ NK158E 37x50.5x7mm, ACM		
		JM7038 (Rubber)			☒ NK158E 37x50.5x7mm, ACM		
		JM7038 (Rubber)					
HBS434 (22-76011B) M12x1.25x152.0mm (x18)							
		HM5264E (x2) 11/02→ 6674					
HBS381⊙ (22-76009B) M12x1.50x183mm (x10)							
HBS478 (22-76025B)							
HBS382⊙ (22-76010B) M12x1.50x183mm (x10)		HM5251E					
HBS455 (22-76016B) M12x1.25x95.0mm (x10)		JN717 (50-028065-00)	JJ268	PA956 (x16)	☒ NJ324E 34x48x7mm, ACM ☒ NJ325E 90x110x9mm, MVQ		
	JC401E HA399E JC400E	JN533 (50-026764-00)	JJ268		☒ NJ324E 34x48x7mm, ACM ☒ NJ325E 90x110x9mm, MVQ		
HBS211⊙ (22-75001B) M12x1.50x113mm (x10)							
	JC598E JC477E ⊙JE102	JN576 (50-026765-00)	JJ268	PA659 (x8)	☒ NJ324E 34x48x7mm, ACM ☒ NJ325E 90x110x9mm, MVQ		



KWPS

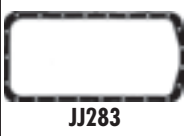

110 2000 i					08/96 →	1	BS720 (Fibre)	DS720	ES720
C 20 XE	1998	4	86.00			110/150	(30-026310-10)	(21-26310-22/0)	(22-27206-00/0)
111 1500					01/96 →	2	BS630 (Fibre)		
VAZ-2111	1499	4	82.00			56-57/ 76-78			
1200 1200					09/73 → 08/84	3		CX660	FX660
1200 1200 L/S					01/70 → 06/86				
BA3 2101	1198	4	76.00	SOHC		44/60			
1300 1300					01/81 → 12/82	4	BH700 (Fibre)	DH700	GH700
BA3 2106	1294	4				49/67			
1300 1300					05/78 → 01/87	5	BS620 (Fibre)	DS620	GS620 [12]
BA3 21011	1285	4	76.00			48/65			
1500 1500					09/73 → 06/85	6		CX660	FX660
1500 1500 N/S					11/75 → 10/86				
BA3 2103	1452	4	76.00	SOHC		54-55/ 73-75			
1600 1600					09/72 → 08/84	7	BH700 (Fibre)	DH700	GH700
1600 1600 N/L					03/79 → 10/86				
BA3 2106	1570	4	79.00	SOHC		56-57/ 76-77			
Aleko 1.9L D Diesel					01/90 →	8	BX880 (Fibre), 1.36mm, 1 Notch [174]	DJ720▲	EL890
XUD9A	1905	4	83.00			47-52/ 64-71	(30-028475-00) ⊖0.56 → 0.67mm	(21-25202-22/0)	(22-25198-01/0)
							BX890 (Fibre), 1.40mm, 2 Notches [175] (30-028476-00) ⊖0.68 → 0.71mm		GJ720▲ (20-25202-02/0)
							BX900 (Fibre), 1.44mm, 3 Notches [176] (30-028477-00) ⊖0.72 → 0.75mm		
							BX910 (Fibre), 1.48mm, 4 Notches [177] (30-028478-00) ⊖0.76 → 0.79mm		
							BX920 (Fibre), 1.52mm, 5 Notches [178] (30-028479-00) ⊖0.80 → 0.83mm		
Niva 1600					12/76 → 03/95	9	BH700 (Fibre)	DH700	GH700
BA3 2121	1569	4	79.00	SOHC		54-56/ 73-76			
Niva 1900 D Diesel					01/93 →	10	BX880 (Fibre), 1.36mm, 1 Notch	DJ720▲	EL890
XUD9A	1905	4	83.00			47-52/ 64-71	(30-028475-00) ⊖0.56 → 0.67mm	(21-25202-22/0)	(22-25198-01/0)
XUD9SD	1905	4	83.00	Indirect Injection, SOHC		55/75	BX890 (Fibre), 1.40mm, 2 Notches (30-028476-00) ⊖0.68 → 0.71mm		GJ720▲ (20-25202-02/0)
							BX900 (Fibre), 1.44mm, 3 Notches (30-028477-00) ⊖0.72 → 0.75mm		
							BX910 (Fibre), 1.48mm, 4 Notches (30-028478-00) ⊖0.76 → 0.79mm		
							BX920 (Fibre), 1.52mm, 5 Notches (30-028479-00) ⊖0.80 → 0.83mm		

								
HBS035  [22-29005B] M11x1.25x110mm (x10) HBS054  [22-29013B] M11x1.25x105mm (x10)	JD455  [31-026335-10] JD430  [31-025888-00]	JM950 [50-026336-10]	JJ459 (x2) [148] [31-027206-00]	PA565 [50-305900-50] HR342  (x2) [24-30590-05/0]	NC006 35x48x7mm, MVQ [50-319161-00] NB884  38x50x5.5mm, FPM [50-319010-00] NB806  90x104x11mm, FPM [50-306552-00]	NB575 [2] [159]	 BH700  BS620  BS630  BS720  BX880, BX890, BX900, BX910, BX920  JC423  JC759  JC872  JD430  JD455  JM077  JM950  JN544  JH881  JJ283  JJ412  JJ459	
	JC872	JM077	JH881	HR569  24-30667-00/0				
		JM077	JH881					
			JJ412					
	JC872	JM077	JH881	HR569  24-30667-00/0				
		JM077	JH881					
HBS084  [22-15005B] M12x1.50x123mm (x10)	JC759 [60] [31-028417-00] (Steel) JC423  (x2) [31-025199-10]	JN544 [50-025202-00]	JJ283 [6] [31-025198-10] PA349 [33-102290-10] 22x16x2mm	HR569  24-30667-00/0	NF841 35x50x8mm, FPM [50-319310-00] NA5191  42x62x7mm, PTFE [50-319500-00] NA5192  90x110x7mm, PTFE [50-319501-00]	HL5010 [245]  NF539 [2]  NF528 [2]  NA5205 [38]  NA5204 [38]  KA611 [13]	 JD430  JD455  JM077  JM950  JN544  JH881  JJ283  JJ412  JJ459	
		JM077	JH881					
HBS084  [22-15005B] M12x1.50x123mm (x10)	JC759 [60] [31-028417-00] (Steel) JC423  (x2) [31-025199-10]	JN544 [50-025202-00]	JJ283 [6] [31-025198-10] PA349 [33-102290-10] 22x16x2mm	HR569  24-30667-00/0	NF841 35x50x8mm, FPM [50-319310-00] NA5191  42x62x7mm, PTFE [50-319500-00] NA5192  90x110x7mm, PTFE [50-319501-00]	HL5010 [245]  NF539 [2]  NF528 [2]  NA5205 [38]  NA5204 [38]  KA611 [13]	 JH881  JJ283  JJ412  JJ459	











KW/PS



Model Name						Year Range	Power (KW/PS)	Configuration	Engine Type	Accessories
Nova 1300 L Spezial						05/81 →	11		BH700 (Fibre)	DH700 ■ GH700
BA3 2105	1294	4	79.00	SOHC		48-51/ 65-70				
Nova 1500						09/85 → 02/93	12			CX660 ■ FX660
Nova 1500 Special						03/85 →				
BA3 2103	1452	4	76.00	SOHC		54-55/ 73-75				
Nova 1500						08/94 →	13			CX660 ■ FX660
BA3 2103 (KAT)	1451	4	76.00	SOHC		49-55/ 67-75				
Nova 1600						01/88 →	14		BH700 (Fibre)	DH700 ■ GH700
BA3 2106	1570	4	79.00	SOHC		56-57/ 76-77				
Samara 1100						02/88 → 12/94	15		BS620 (Fibre)	DS620 GS620 [12]
BA3 21081 (KAT)	1099	4	76.00	SOHC		39-43/ 53-58				
BA3 21081	1100	4	76.00	SOHC		39/53				
Samara 1300						01/86 → 07/97	16		BS620 (Fibre)	DS620 GS620 [12]
BA3 2108 (KAT)	1288	4	76.00	SOHC		44-45/ 60-62				
BA3 2108	1288	4	76.00	SOHC		45-48/ 61-65				
BA3 21115	1288	4	82.00			50/68				
Samara 1500						01/88 →	17		BS630 (Fibre)	GS630
BA3 21083	1499	4	82.00	SOHC		53/72				
BA3 21083 (KAT)	1500	4	82.00	SOHC		50/68				
Toscana 1500						09/83 → 02/93	18			CX660 ■ FX660
BA3 2103	1452	4	76.00	SOHC		54-55/ 73-75				

		JM077					
	JC872	JM077	JH881	HR569 24-30667-00/0			
	JC872	JM077	JH881	HR569 24-30667-00/0			
		JM077	JH881				
			JJ412				
			JJ412				
	JC872		JJ412				
	JC872	JM077	JH881	HR569 24-30667-00/0			







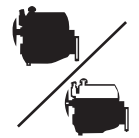



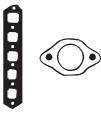

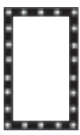

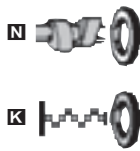























































		CC			9			CC			9
138 C2.048	Petrol	1498	4	86.40	64	834 F2.000	Petrol	1995	4	84.00	69
156 A 1.000	Petrol	1049	4	76.00	100	835 A1.000	Petrol	1581	4	86.40	3
156 A 2.000	Petrol	999	4	70.00	96	835 A1.046	Petrol	1581	4	86.40	5
156 A 2.000	Petrol	999	4	70.00	97	835 A2.000	Petrol	1756	4	84.00	8
156 A 2.100	Petrol	999	4	70.00	98	835 A2.046	Petrol	1756	4	84.00	9
156 A2.246	Petrol	999	4	70.00	99	835 A4.000	Diesel	1929	4	82.60	11
156 B.000	Petrol	1301	4	76.10	103	835 A4.000	Diesel	1929	4	82.60	30
156 C.000	Petrol	1108	4	70.00	102	835 A4.046	Diesel	1929	4	82.60	11
159 B9.000	Petrol	1581	4	86.40	1	835 A5.000	Petrol	1995	4	84.00	14
160 A1.046	Petrol	1372	4	80.50	20	835 A5.046	Petrol	1995	4	84.00	15
160 D1.000	Diesel	1929	4	82.60	11	835 A7.000	Petrol	1995	4	84.00	17
160 D1.000	Diesel	1929	4	82.60	30	835 A7.046	Petrol	1995	4	84.00	13
175 A3.000	Petrol	1998	5	82.00	38	835 A8.000	Petrol	1995	4	84.00	17
176 B2.000	Petrol	1108	4	70.00	101	835 A8.046	Petrol	1995	4	84.00	16
176 B2.000	Petrol	1108	4	70.00	91	835 C1.000	Petrol	1581	4	86.40	25
176 B9.000	Petrol	1242	4	70.80	94	835 C1.000	Petrol	1581	4	86.40	4
182 A2.000	Petrol	1747	4	82.00	28	835 C2.000	Petrol	1756	4	84.00	27
182 A2.000	Petrol	1747	4	82.00	6	835 C4.000	Petrol	1756	4	84.00	27
182 A4.000	Petrol	1581	4	86.40	2	836 A3.000	Petrol	1995	4	84.00	12
182 A4.000	Petrol	1581	4	86.40	26	836 A3.000	Petrol	1995	4	84.00	32
182 A4.000	Petrol	1581	4	86.40	43	836 A4.000	Petrol	1372	4	80.50	20
182 A6.000	Petrol	1581	4	86.40	26	836 A5.000	Petrol	1756	4	84.00	10
182 B7.000	Petrol	1998	5	82.00	48	836 A6.000	Petrol	1756	4	84.00	27
183 A1.000	Petrol	1747	4	82.00	29	836 C4.000	Petrol	1756	4	84.00	27
183 A1.000	Petrol	1747	4	82.00	7	838 A1.000	Petrol	1998	5	82.00	36
185 A8.000	Petrol	1998	5	82.00	49	838 A2.000	Petrol	2446	5	83.00	39
188 A4.000	Petrol	1242	4	70.80	104	838 A2.027	Petrol	2446	5	83.00	39
188 A4.000	Petrol	1242	4	70.80	92	838 A3.000	Diesel	2387	5	82.00	41
188 A5.000	Petrol	1242	4	70.80	105	838 A4.000	Petrol	1995	4	84.00	35
188 A5.000	Petrol	1242	4	70.80	93	838 A6.000	Petrol	1998	5	82.00	37
188 A9.000	Diesel	1248	4	69.60	108	838 A7.000	Diesel	2387	5	82.00	41
188 A9.000	Diesel	1248	4	69.60	53	838 A8.000	Diesel	2387	5	82.00	40
188 B2.000	Diesel	1910	4	82.00	56	838 B.000	Petrol	2959	6	93.00	42
199 A2.000	Diesel	1248	4	69.60	106	839 A4.000	Petrol	1747	4	82.00	44
199 A3.000	Diesel	1248	4	69.60	107	839 A4.000	Petrol	1747	4	82.00	45
199 A3.000	Diesel	1248	4	69.60	52	839 A5.000	Diesel	2387	5	82.00	50
350 A1.000	Petrol	1368	4	72.00	110	839 A6.000	Diesel	2387	5	82.00	51
350 A1.000	Petrol	1368	4	72.00	55	839 A7.000	Petrol	1747	4	82.00	44
4HW(DW12ATED4)	Diesel	2179	4	85.00	61	839 A7.000	Petrol	1747	4	82.00	45
8140.97.2200	Diesel	2499	4	93.00	78	839 A9.000	Petrol	1747	4	82.00	44
8140.97.2500	Diesel	2499	4	93.00	78	840 A2.000	Petrol	1370	4	82.00	95
8144. 97S	Diesel	2500	4	93.00	80	840 A3.000	Petrol	1242	4	70.80	92
8144.91	Diesel	2445	4	93.00	77	840 A4.000	Petrol	1370	4	82.00	95
8144.97	Diesel	2499	4	93.00	79	841 G.000	Diesel	2387	5	82.00	88
8144.97	Diesel	2499	4	93.00	80	841 P.000	Diesel	2387	5	82.00	85
8144.97 Y	Diesel	2499	4	93.00	81	841A.000	Petrol	2959	6	93.00	89
8144.97 Y	Diesel	2499	4	93.00	82	841C.000	Diesel	2387	5	82.00	51
828 B7.000	Petrol	1995	4	84.00	90	841C.000	Diesel	2387	5	82.00	87
831 A7.000	Petrol	1585	4	84.00	22	841D.000	Petrol	2446	5	83.00	86
831 B1.000	Petrol	1498	4	86.40	65	841E.000	Petrol	1998	5	82.00	84
831 B1.048	Petrol	1498	4	86.40	64	843 A 1.000	Petrol	1368	4	72.00	109
831 B3.000	Petrol	1585	4	84.00	23	843 A 1.000	Petrol	1368	4	72.00	54
831 B7.000	Petrol	1585	4	84.00	21	937 A2.000	Diesel	1910	4	82.00	47
831 B7.000	Petrol	1585	4	84.00	66	AR 32302	Diesel	1910	4	82.00	46
831 B8.000	Petrol	1116	4	80.00	18	AR 32501	Diesel	2387	5	82.00	50
831 C5.046	Petrol	1995	4	84.00	34	AR 37101	Diesel	1910	4	82.00	47
831 D.000	Diesel	1929	4	82.60	67	DW10ATED4 (RHM)	Diesel	1997	4	85.00	60
831 D1.000	Diesel	1929	4	82.60	31	DW10ATED4 (RHW)	Diesel	1998	4	85.00	113
834 B.048	Petrol	1995	4	84.00	71	DW10ATED4 (RHW)	Diesel	1998	4	85.00	59
834 B.146	Petrol	1995	4	84.00	72	ES9 J4S	Petrol	2946	6	87.00	62
834 B1.000	Petrol	1995	4	84.00	71	P 8 C	Diesel	2088	4	85.00	115
834 B2.000	Petrol	1995	4	84.00	73	RFN	Petrol	1997	4	85.00	112
834 B2.246	Petrol	1995	4	84.00	73	RFN(EW10J4)	Petrol	1997	4	85.00	58
834 C.000	Petrol	1995	4	84.00	75	RGX (XU 10)	Petrol	1998	4	86.00	114
834 C.146	Petrol	1995	4	84.00	76	RHK	Diesel	1997	4	85.00	57
834 C1.000	Petrol	1995	4	84.00	70	RHR	Diesel	1997	4	85.00	57
834 C1.000	Petrol	1995	4	84.00	74	XU10 (RFV)	Petrol	1998	4	86.00	111
834 F.000	Petrol	2959	6	93.00	83						
834 F1.000	Petrol	1995	4	84.00	68						



KW/PS



Dedra 1.6L LE		07/94 → 07/99		1				
Dedra 1.6L SW		10/94 → 07/99						
159 B9.000	1581	4	86.40		66/89			
Dedra 1.6L 16V		01/96 → 07/99		2		BX030 (Fibre), 1.65mm (30-028381-00) AY470 (Fibre), 1.85mm [249] (30-029903-00)	CY470 [157] (21-29903-20/0) DX030 (21-28381-20/0)	EB5150 (22-29342-00/0) GX030 (20-28381-00/0)
182 A4.000	1581	4	86.40	Injection, DOHC				
Dedra 1.6L i.e.		08/89 → 06/94		3		AY460 (Fibre) [249] BR630 (Fibre) (30-027866-00)	DR630 (21-26294-21/0) 01/89 → 01/93 DR632 (21-27866-21/0) 01/93 →	GR632 (20-27866-01/0)
835 A1.000	1581	4	86.40	SPi	55/75			
Dedra 1.6L i.e.		04/93 → 07/99		4		AY460 (Fibre) [249] BR630 (Fibre) (30-027866-00)	DR632 (21-27866-21/0)	GR632 (20-27866-01/0)
835 C1.000	1581	4	86.40	SPi	55/75			
Dedra 1.6L i.e.		08/89 → 03/93		5		AY500 (Fibre) [249] BT440 (Fibre) (30-026647-30)	DT449 (21-26647-30/0)	GT449 (20-26647-11/0)
835 A1.046	1581	4	86.40	SPi	55/75			
Dedra 1.8L 16V LE		03/96 → 07/99		6		AY500 (Fibre) [249] BW720 (Fibre), 1.65mm (30-028382-00)	DW720 (21-28382-20/0)	GW724
182 A2.000	1747	4	82.00	Injection, DOHC				
Dedra 1.8L GT 16V		03/96 → 07/99		7		AY500 (Fibre) [249] BW720 (Fibre), 1.65mm [168] (30-028382-00)	DW723 ■ (21-28382-23/0)	EA5420 (22-29064-00/0) GW723
183 A1.000	1747	4	82.00	Injection, DOHC				
Dedra 1.8L i.e.		09/89 → 06/94		8		BT410 (Fibre) BT420 (Fibre) (30-025413-10)	DT410 (21-26479-26/0)	GT410
835 A2.000	1756	4	84.00		79/107			
Dedra 1.8L i.e.		09/89 → 07/99		9		BT410 (Fibre) BT420 (Fibre) (30-025413-10)	DT410 (21-26479-26/0)	GT410
835 A2.046	1756	4	84.00		79/107			
Dedra 1.8L i.e.		07/94 → 07/99		10		AY500 (Fibre) [249] BT440 (Fibre) (30-026647-30)	DT449 (21-26647-30/0)	GT449 (20-26647-11/0)
836 A5.000	1756	4	84.00	i.e.	76/103			

								
HBS051  (22-17001B) M10x1.25x98mm (x5) M10x1.25x84mm (x5)								 AY460, BR630
HBS131  (22-17014B) M10x1.25x100mm (x10)	JD340  (31-028789-00) JD566  HA5005  (24-29252-00/0) JD5143  (31-028790-10)	JN973 (31-028483-00)	HR354 [94] JJ453	HR800 	 NA5187 (x2) 30x52x7mm, ACM (50-319492-00)  NB818 40x56x7mm, ACM  NF887 [3] 64x112.5x20mm, FPM (50-319393-00)			 AY500
HBS092  (22-17003B) M10x1.25x115mm (x10) →12/93 HBS051  (22-17001B) M10x1.25x98mm (x5) M10x1.25x84mm (x5) 01/94→	JD146 (31-027221-10)	JN805 [156] (31-026819-00) JP049 (31-026820-00)	JJ453	HR363 	 NA5187 (x2) 30x52x7mm, ACM (50-319492-00)  NA5051 40x56x7mm, FPM  NB818 40x56x7mm, ACM	KA294 [13]		 BT410
HBS092  (22-17003B) M10x1.25x115mm (x10) HBS051  (22-17001B) M10x1.25x98mm (x5) M10x1.25x84mm (x5) 01/93→	JD146 (31-027221-10)	JP049 (31-026820-00) JN805 [156] (31-026819-00) 01/89→12/92	JJ453	HR363 	 NA5187 (x2) 30x52x7mm, ACM (50-319492-00)  NB818 40x56x7mm, ACM	KA294 [13]		 BT440, BT420
HBS092  (22-17003B) M10x1.25x115mm (x10)				HR363 	 NA5187 (x2) 30x52x7mm, ACM (50-319492-00)  NB742 30x43x8mm, ACM (50-319408-00)  NB732 74x90x10mm, FPM  NA5062 74x90x10mm, ACM			 BW720
HBS132  (22-17015B) M10x1.25x254mm (x10)	JD271  (31-027450-10) (Metal) JD273  (31-027729-00) (MLS)	HL701  (24-28782-00/0)	JJ535 (31-028781-00)		 NA5053 30x42x7mm, FPM (50-319488-00)  NA5070 31x41x7mm, FPM (50-319524-00)  NF888 [3] 93x139.7x12mm, FPM (50-319526-00)	HL5031 [245] 		 BX030, AY470
HBS132  (22-17015B) M10x1.25x254mm (x10)	JA5007  JD273  (31-027729-00) (MLS)	HL701  (24-28782-00/0)	JJ535 (31-028781-00)					 HA5005
HBS092  (22-17003B) M10x1.25x115mm (x10)	JC662  (31-026050-10) JA757  (31-022346-10)	JN643 (x2) (31-027225-00) JN948 (x2) (31-027428-00)	JJ298 JJ413 (31-027315-00)	HR363 				 JA5007
HBS092  (22-17003B) M10x1.25x115mm (x10)	JC662  (31-026050-10) JA757  (31-022346-10)	JN643 (x2) (31-027225-00) JN948 (x2) (31-027428-00)	JJ298 JJ413 (31-027315-00)	HR363 	 NB742 30x43x8mm, ACM (50-319408-00)  NB732 74x90x10mm, FPM			 JA757
HBS092  (22-17003B) M10x1.25x115mm (x10)				HR363 	 NA5187 (x2) 30x52x7mm, ACM (50-319492-00)  NB742 30x43x8mm, ACM (50-319408-00)  NB732 74x90x10mm, FPM  NA5062 74x90x10mm, ACM			 JC662

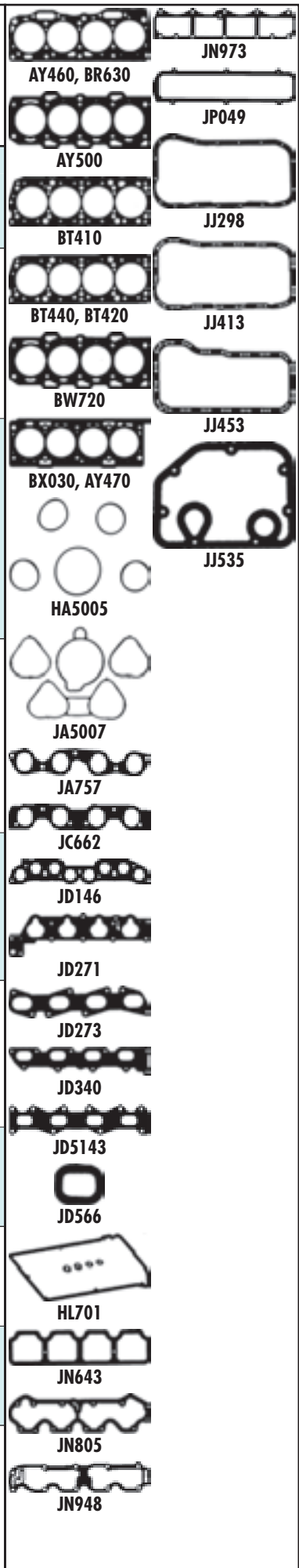





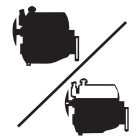



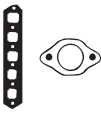

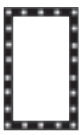

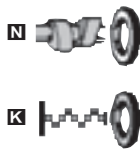













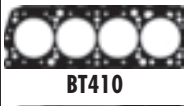



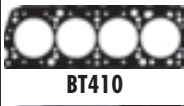

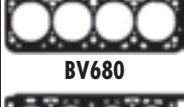

















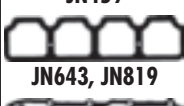











KW/PS

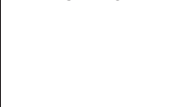

Dedra 1.9L TDS Diesel		04/89 → 07/99		11		BR680 (Graphite), 1.65mm BV680 (Fibre), 1.67mm, 0 Notches (30-026296-10) BR690 (Graphite), 1.80mm, 1 Notch (30-025167-10) BR700 (Graphite), 1.95mm, 2 Notches (30-026298-10)		DV680▲ (21-25142-26/0)		GV680▲ [100]	
160 D1.000	1929	4	82.60	SOHC	66/90						
835 A4.000/835 A4.046	1929	4	82.60		68/92						
Dedra 2.0L 16V		07/94 → 07/99		12		BT440 (Fibre) (30-026647-30)		DT448		GT448	
Dedra 2.0L Integrale		07/94 → 07/99									
836 A3.000	1995	4	84.00		102/139						
Dedra 2.0L HF		11/90 → 07/94		13							
835 A7.046	1995	4	84.00		130/177						
Dedra 2.0L i.e.		09/89 → 07/92		14		BT440 (Fibre) (30-026647-30)		DT440		GT440 (20-26647-02/0)	
835 A5.000	1995	4	84.00	i.e.	88/120						
Dedra 2.0L i.e.		09/89 → 07/99		15		BT440 (Fibre) (30-026647-30)		DT446 (21-26647-23/0)		GT446 [12] (20-26647-03/0)	
835 A5.046	1995	4	84.00		83/113						
Dedra 2.0L i.e. Turbo		04/91 → 07/99		16		AY500 (Fibre) [249] BT440 (Fibre) (30-026647-30)		DT449 (21-26647-30/0)		GT449 (20-26647-11/0)	
835 A8.046	1995	4	84.00	Injection	119/162						
Dedra 2.0L i.e. Turbo Integrale		05/90 → 07/94		17		BT420 (Fibre) (30-025413-10)		DT423■		GT423 [12]	
Dedra 2.0L Turbo		11/90 → 06/94									
835 A7.000	1995	4	84.00		130/177						
835 A8.000	1995	4	84.00	Injection, DOHC	132- 130/ 180- 177						
Delta 1.1L		01/86 → 12/90		18		AY450 (Fibre) [168] [249] BR620 (Fibre) [249] (30-027865-00)					
831 B8.000	1116	4	80.00		47/64						
Delta 1.3L		09/83 → 08/92		19		BP110 (Fibre) (30-024119-10)					
	1301	4			58/79						
Delta 1.4L i.e.		10/94 → 08/99		20		AY450 (Fibre) [168] [249] BR620 (Fibre) [249] (30-027865-00)					
160 A1.046/836 A4.000	1372	4	80.50		51/69						
Delta 1.6L GT i.e.		08/86 → 08/88		21		BT410 (Fibre) BT440 (Fibre) (30-026647-30) BX030 (Fibre), 1.65mm (30-028381-00)		DT411 [12] (21-25413-23/0)		GT411 [12]	
831 B7.000	1585	4	84.00		80/109						
Delta 1.6L HF Turbo		10/83 → 12/86		22				DR130		GR130	
831 A7.000	1585	4	84.00		96/131						











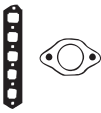

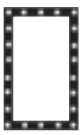

















































								
HBS095  (22-17007B) M12x1.25x133mm (x10)	JC738 (31-026290-10)	JN459 (31-025142-10)	JJ298 JJ398 (31-027379-00)	HR363  HR596 	NA5187 30x52x7mm, ACM (50-319492-00) NB742 30x43x8mm, ACM (50-319408-00) NB732 74x90x10mm, FPM NA5062 74x90x10mm, ACM	LB175 [70] LV586 [70] LV583 [53] HJ283 [39]  JR749 [11] JS081 [11]		AY450, BR620  JJ298  AY500  JJ366  BP110  JJ398  BR680, BR690, BR700  JJ413  BT410  BT440, BT420 
HBS093  (22-17005B) M10x1.25x172mm (x10)	JD153  (31-027321-00) JD151 (31-027331-00)	JN928 [102] (50-027319-00)	JJ413 (31-027315-00)	HR800 	NA5053 30x42x7mm, FPM (50-319488-00) NB742 30x43x8mm, ACM (50-319408-00) NB732 74x90x10mm, FPM	LB175 [70] JR749 [11] JS081 [11] KT639 [11] OK473 [160]		BR680, BR690, BR700  BT410 
HBS092  (22-17003B) M10x1.25x115mm (x10)								BT440, BT420 
HBS092  (22-17003B) M10x1.25x115mm (x10)	JC662  (31-026050-10) JA757  (31-022346-10)	JN643 (31-027225-00) JN819 JN928 [102] (50-027319-00) JN948 (31-027428-00)	JJ298 JJ366 (31-027488-00) JJ413 (31-027315-00)	HR363 	NA5187 (x2) 30x52x7mm, ACM (50-319492-00) NB742 30x43x8mm, ACM (50-319408-00) NB732 74x90x10mm, FPM NA5062 74x90x10mm, ACM	LB175 [70] OK627 [14] KT465 [54] JR749 [11] JS081 [11] KT639 [11] LV585 [45] OK473 [160]		BV680  BX030 
HBS092  (22-17003B) M10x1.25x115mm (x10)								JA757 
HBS092  (22-17003B) M10x1.25x115mm (x10)				HR363 	NA5187 (x2) 30x52x7mm, ACM (50-319492-00) NB742 30x43x8mm, ACM (50-319408-00) NB732 74x90x10mm, FPM NA5062 74x90x10mm, ACM			JC662 
HBS092  (22-17003B) M10x1.25x115mm (x10)	JC662  (31-026050-10) JD019  (31-027032-10)	JN693 [128] (31-026198-10)	JJ366 (31-027488-00) JJ413 (31-027315-00)					JC693 
HBS051  (22-17001B) M10x1.25x98mm (x5) M10x1.25x84mm (x5)								JC738 
HBS051  (22-17001B) M10x1.25x98mm (x5) M10x1.25x84mm (x5)								JD019 
HBS051  (22-17001B) M10x1.25x98mm (x5) M10x1.25x84mm (x5)								JD151 
HBS051  (22-17001B) M10x1.25x98mm (x5) M10x1.25x84mm (x5)	JC662  (31-026050-10) JA757  (31-022346-10)	JN643 (31-027225-00) JN645 [156] (31-027441-00)	JJ298 JJ413 (31-027315-00)	HR363 				JD153 
HBS051  (22-17001B) M10x1.25x98mm (x5) M10x1.25x84mm (x5)							KA294 [13]	JN459 
HBS051  (22-17001B) M10x1.25x98mm (x5) M10x1.25x84mm (x5)	JC662  (31-026050-10) JA757  (31-022346-10)	JN643 (31-027225-00) JN645 [156] (31-027441-00)	JJ298 JJ413 (31-027315-00)	HR363 				JN643, JN819 
HBS092  (22-17003B) M10x1.25x115mm (x10)	JC693 							JN645 
								JN693 
								JN928
								JN948



KW/PS



Delta 1.6L HF Turbo		08/86 → 08/88		23		BT420 (Fibre) (30-025413-10)			
831 B3.000	1585	4	84.00	Injection, DOHC					
Delta 1.6L HF Turbo		08/86 → 05/93		24					
	1585	4			122/166				
Delta 1.6L i.e.		06/93 → 08/99		25		AY460 (Fibre) [249] BR630 (Fibre) (30-027866-00)		DR632 (21-27866-21/0)	GR632 (20-27866-01/0)
835 C1.000	1581	4	86.40	SPi	55/75				
Delta 1.6L i.e.		03/96 → 08/99		26		BT440 (Fibre) (30-026647-30)		CY470 [157] (21-29903-20/0)	EB5150 (22-29342-00/0)
Delta 1.6L i.e. 16V		01/96 → 08/99				BX030 (Fibre), 1.65mm (30-028381-00) AY470 (Fibre), 1.85mm [249] (30-029903-00)		DX030 (21-28381-20/0)	
182 A4.000/182 A6.000	1581	4	86.40	Injection, DOHC					
Delta 1.8L i.e.		06/93 → 08/99		27		BT440 (Fibre) (30-026647-30)		DT449 (21-26647-30/0)	GT449 (20-26647-11/0)
835 C2.000	1756	4	84.00	Injection	76/103				
835 C4.000/ 836 A6.000/836 C4.000	1756	4	84.00	i.e.	76/103				
Delta 1.8L i.e. 16V		03/96 → 08/99		28		AY500 (Fibre) [249] BW720 (Fibre), 1.65mm (30-028382-00)		DW720 (21-28382-20/0)	GW724
182 A2.000	1747	4	82.00	Injection, DOHC					
Delta 1.8L i.e. 16V GT		03/96 → 08/99		29		AY500 (Fibre) [249] BW720 (Fibre), 1.65mm (30-028382-00)		DW723 ■ (21-28382-23/0)	EA5420 (22-29064-00/0) GW723
183 A1.000	1747	4	82.00	Injection, DOHC					
Delta 1.9L TD Diesel		10/94 → 08/99		30		BR680 (Graphite), 1.65mm BV680 (Fibre), 1.67mm, 0 Notches (30-026296-10) BR690 (Graphite), 1.80mm, 1 Notch (30-025167-10) BR700 (Graphite), 1.95mm, 2 Notches (30-026298-10)		DV680 ▲ (21-25142-26/0)	GV680 ▲ [100]
160 D1.000	1929	4	82.60	SOHC	66/90				
835 A4.000	1929	4	82.60		68/92				
Delta 1.9L Turbo DS Diesel		10/86 → 12/89		31		BR680 (Graphite), 1.65mm BV680 (Fibre), 1.67mm, 0 Notches (30-026296-10) BR690 (Graphite), 1.80mm, 1 Notch (30-025167-10) BR700 (Graphite), 1.95mm, 2 Notches (30-026298-10)		DT290 ▲ (21-25950-21/0)	GV680 ▲ [100]
831 D1.000	1929	4	82.60		62/84				
Delta 2.0L 16V		06/93 → 08/99		32		BT440 (Fibre) (30-026647-30)		DT448	GT448
836 A3.000	1995	4	84.00		102/139				











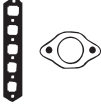

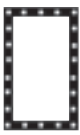



























































								
HBS092  (22-17003B) M10x1.25x115mm (x10)								 AY460, BR630
HBS092  (22-17003B) M10x1.25x115mm (x10)								 AY500
HBS092  (22-17003B) M10x1.25x115mm (x10) HBS051  (22-17001B) M10x1.25x98mm (x5) M10x1.25x84mm (x5) 01/93→	JD146 (31-027221-10) JN805 [156] (31-026819-00) 01/89→12/92	JP049 (31-026820-00) JN805 [156] (31-026819-00) 01/89→12/92	JJ453	HR363 	 NA5187 (x2) 30x52x7mm, ACM (50-319492-00)  NB818E 40x56x7mm, ACM	KA294 [13] KA354 [13]		 JE187
HBS131  (22-17014B) M10x1.25x100mm (x10)	JD340  (31-028789-00) JD566  HA5005  (24-29252-00/0) JD5143  (31-028790-10)	JN973 (31-028483-00)	HR354 [94] JJ453	HR800 	 NA5187 (x2) 30x52x7mm, ACM (50-319492-00)  NB818E 40x56x7mm, ACM  NF887E [3] 64x112.5x20mm, FPM (50-319393-00)			 BR680, BR690, BR700
HBS092  (22-17003B) M10x1.25x115mm (x10)	JC662  (31-026050-10) JD019  (31-027032-10)							 BT420, BT440
HBS132  (22-17015B) M10x1.25x254mm (x10)	JD271  (31-027450-10) (Metal) JD273  (31-027729-00) (MLS)							 BV680
HBS132  (22-17015B) M10x1.25x254mm (x10)	JA5007  JD273  (31-027729-00) (MLS)							 BW720
HBS095  (22-17007B) M12x1.25x133mm (x10)	JC738 (31-026290-10)  JE187	JN459 (31-025142-10)	JJ298 JJ398 (31-027379-00)	HR596 	 NA5187 30x52x7mm, ACM (50-319492-00)  NB742E 30x43x8mm, ACM (50-319408-00)  NB732E 74x90x10mm, FPM  NA5062E 74x90x10mm, ACM	LB175 [70] LV586 [70] LV583 [53] HJ283 [39]  JR749 [11] JS081 [11]		 JN928
HBS095  (22-17007B) M12x1.25x133mm (x10)	JC738 (31-026290-10)  JE187	JN568 (31-025950-10)	JJ298 JJ398 (31-027379-00)	HR596 	 NA5187 30x52x7mm, ACM (50-319492-00)  NB742E 30x43x8mm, ACM (50-319408-00)  NB732E 74x90x10mm, FPM	LV583 [53] HJ277 [39]  LT019 [86] JR749 [11] KT639 [11]		 JN459
HBS093  (22-17005B) M10x1.25x172mm (x10)	JD153  (31-027321-00) JD151 (31-027331-00)	JN928 [102] (50-027319-00)	JJ413 (31-027315-00)		 NA5053 30x42x7mm, FPM (50-319488-00)  NB742E 30x43x8mm, ACM (50-319408-00)  NB732E 74x90x10mm, FPM  NA5062E 74x90x10mm, ACM	LB175 [70] JR749 [11] JS081 [11] KT639 [11] OK473 [160]		 JN568



KW/PS

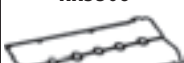

Delta 2.0L 16V HF Evo Integrale		06/93 → 01/94		33		BT440 (Fibre) (30-026647-30)	DT447 (21-26647-27/0)	GT447
Delta 2.0L 16V Turbo		06/93 → 08/99						
175 A4.000/831 E5.000/ 831 E5.046/836 A2.000	1995	4	84.00	Injection	137/186			
Delta 2.0L HF Integrale		12/86 → 12/92		34		BT420 (Fibre) (30-025413-10)	DT423 ■	GT423 [12]
Delta 2.0L HF Integrale		12/86 → 12/92						
831 C5.046	1995	4	84.00		130/177			
Kappa 2.0L 16V Turbo		02/95 → 10/01		35		BT440 (Fibre) (30-026647-30)	DT448	GT448
Kappa Coupe 2.0L 16V Turbo		11/96 → 03/01						
838 A4.000	1995	4	84.00		150/204			
Kappa 2.0L 20V		10/94 → 10/01		36		BW320 (Fibre) (30-027452-00)	DW320 (21-27452-20/0)	
Kappa 2.0L 20V		10/94 → 10/01						
838 A1.000	1998	5	82.00		108/147			
Kappa 2.0L 20V		07/96 → 10/01		37		BW320 (Fibre) (30-027452-00)	DW322 (21-27452-21/0)	EW320 (22-27452-00/0)
Kappa Coupe 2.0L 20V		07/96 → 03/01						
838 A6.000	1998	5	82.00		113/154			
Kappa 2.0L 20V Turbo		06/98 → 10/01		38		AY320 (MLS), 1.80mm (30-029072-00)	CY320 (21-29813-20/0)	FY320 (20-29813-00/0)
Kappa Coupe 2.0L 20V Turbo		06/98 → 03/01						
175 A3.000	1998	5	82.00		162/220			
Kappa 2.4L 20V		08/94 → 10/01		39		BW330 (Fibre) (30-027445-00)	DW330 (21-27445-20/0)	ED5960 (22-29778-00/0)
Kappa Coupe 2.4L 20V		11/96 → 03/01						
838 A2.000/838 A2.027	2446	5	83.00	i.e.	129/175			
Kappa 2.4L JTD Diesel		06/98 → 10/01		40		AY550 (MLS), 1.60mm (30-029020-00) AY560 (MLS), 1.70mm, 1 Hole (30-029021-00) AY570 (MLS), 1.80mm, 2 Holes (30-029022-00)	CY520 ▲ [106] (21-29020-20/0)	FY520 ▲ [106] (20-29020-00/0)
Kappa 2.4L JTD Diesel		06/98 → 10/01						
838 A8.000	2387	5	82.00	Direct Injection, SOHC	100/136			







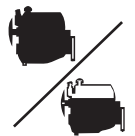



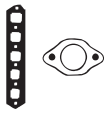

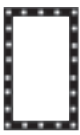



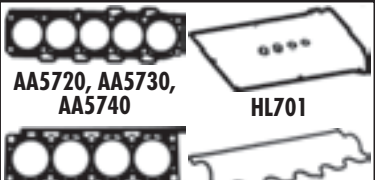





























								 AY320
HBS093  (22-17005B) M10x1.25x172mm (x10)	JD151 (31-027331-00) JD152  (31-027272-00)	JN928 [102] (50-027319-00)	JJ413 (31-027315-00)				LB175 [70] JR749 [11] JS081 [11] KT639 [11] OK473 [160]	 AY550, AY560, AY570
HBS092  (22-17003B) M10x1.25x115mm (x10)								 BT440, BT420
HBS093  (22-17005B) M10x1.25x172mm (x10)	JD153  (31-027321-00) JD151 (31-027331-00)	JN928 [102] (50-027319-00)	JJ413 (31-027315-00)			NA5053 30x42x7mm, FPM (50-319488-00) NB742  30x43x8mm, ACM (50-319408-00) NB732  74x90x10mm, FPM NA5062  74x90x10mm, ACM	LB175 [70] HJ283 [39]  JR749 [11] JS081 [11] KT639 [11] OK473 [160]	 BW320, BW330
HBS132  (22-17015B) M10x1.25x254mm (x10)	JD225  (31-027448-00) JD226  (31-028581-00)					NA5053 30x42x7mm, FPM (50-319488-00) NA5070  31x41x7mm, FPM (50-319524-00) NF888  [3] 93x139.7x12mm, FPM (50-319526-00)	HL5031 [245] 	 JA5036
HBS133  (22-17016B) M10x1.25x254mm (x12)	JD225  (31-027448-00) KK5506  (31-029694-00) KK5507  (31-029695-00) JD226  (31-028581-00)	JM5018 (Rubber)		HR800 		NA5053 30x42x7mm, FPM (50-319488-00) NA5069 55x68x8mm, FPM (50-319515-00) NA5070  31x41x7mm, FPM (50-319524-00) NF888  [3] 93x139.7x12mm, FPM (50-319526-00)	HL5030 [245]  HJ283 [39] 	 JD151
HBS133  (22-17016B) M10x1.25x254mm (x12)	JD225  (31-027448-00) JD226  (31-028581-00)	JN933 (50-028787-00)		HR800 		NA5053 30x42x7mm, FPM (50-319488-00) NA5069 55x68x8mm, FPM (50-319515-00) NA5070  31x41x7mm, FPM (50-319524-00) NF888  [3] 93x139.7x12mm, FPM (50-319526-00)	HL5030 [245]  KL477 [70]	 JD152
HBS133  (22-17016B) M10x1.25x254mm (x12)	JD225  (31-027448-00) KK5506  (31-029694-00) KK5507  (31-029695-00) JD226  (31-028581-00)	JN933 (50-028787-00)		HR800 		NA5053 30x42x7mm, FPM (50-319488-00) NA5069 55x68x8mm, FPM (50-319515-00) NA5070  31x41x7mm, FPM (50-319524-00) NF888  [3] 93x139.7x12mm, FPM (50-319526-00)	HL5030 [245]  KL477 [70] KA845 [13]	 JD153
HBS257  (22-56010B) M12x1.25x218mm (x12)	JD581  →02/00 JA5036  (31-029408-00) 02/00 → JD228  (31-027837-10)	JP064		HR363 		NA5053 30x42x7mm, FPM (50-319488-00) NA5070  31x41x7mm, FPM (50-319524-00) NF888  [3] 93x139.7x12mm, FPM (50-319526-00)	HL5031 [245]  KL477 [70] KA845 [13] JR5001 [11]	 JD225
								 JD226
								 JD228
								 JD581
								 KK5506
								 JM5018
								 JN928
								 JN933
								 JP064
								 JJ413



KW/PS



Kappa 2.4L T.DS Diesel		08/94 → 10/01		41		BW340 (Fibre), 1.60mm (30-027442-20) →Eng.0345336 BW350 (Fibre), 1.70mm, 1 Notch (30-027443-20) →Eng.0345336 BW360 (Fibre), 1.80mm, 2 Notches (30-027444-20) →Eng.0345336 AA5720 (MLS), 1.60mm (30-029066-00) Eng.0345337 → AA5730 (MLS), 1.70mm, 1 Notch (30-029067-00) Eng.0345337 → AA5740 (MLS), 1.80mm, 2 Notches (30-029068-00) Eng.0345337 →	DW340▲ (21-28780-20/0)	GW341▲
838 A3.000/838 A7.000	2387	5	82.00		91/124			
Kappa 3.0L 24V		08/94 → 10/01		42				
Kappa 3.0L 24V SW		07/96 → 10/01						
Kappa Coupe 3.0L 24V		11/96 → 03/01						
838 B.000	2959	6	93.00	Motronic, DOHC, V6				
Lybra 1.6L 16V		07/99 →		43		AB5150 (Fibre) (30-029342-00) →Eng.505168 182 B6.000 BX030 (Fibre), 1.65mm (30-028381-00) AY470 (Fibre), 1.85mm [249] (30-029903-00) 182 A4.000 AD5970 (MLS) (30-029779-00) Eng.505169 → 182 B6.000	CB5150 →Eng.505168 182 B6.000 CD5970 (21-29779-20/0) CY470 [157] (21-29903-20/0) 182 A4.000 DX030 (21-28381-20/0) 182 A4.000	EB5150 (22-29342-00/0) GX030 (20-28381-00/0) →Eng.9508753 182 A4.000
182 A4.000	1581	4	86.40	Injection, DOHC				
Lybra 1.8L 16V		07/99 →		44		AY500 (Fibre) [249] BW720 (Fibre), 1.65mm (30-028382-00)	DW723■ (21-28382-23/0)	GW723
839 A4.000/ 839 A7.000/839 A9.000	1747	4	82.00	Injection, DOHC				
Lybra 1.8L 16V		07/99 →		45		AA5420 (MLS), 0.38mm (30-029064-00)	CA5421 (21-29064-21/0) DW723■ (21-28382-23/0)	EA5420 (22-29064-00/0)
839 A4.000/839 A7.000	1747	4	82.00	Injection, DOHC				
Lybra 1.9L JTD Diesel		07/99 → 09/00		46		AY520 (MLS), 1.60mm, 0 Holes (30-029023-10) AY530 (MLS), 1.70mm, 1 Hole (30-029024-10) AY540 (MLS), 1.80mm, 2 Holes (30-029025-10)	CY550▲ (21-29023-20/0)	FY550▲ (20-29023-00/0)
AR 32302	1910	4	82.00	Direct Injection, SOHC				

							
HBS257  (22-56010B) M12x1.25x218mm (x12)	JD227  (31-027451-00) JD228  (31-027837-10)	JN934 (50-028780-00)		HR363 	NA5053 30x42x7mm, FPM (50-319488-00) NA5070  31x41x7mm, FPM (50-319524-00) NF888  [3] 93x139.7x12mm, FPM (50-319526-00)	HL5031 [245] 	
HBS272  (22-53016B) M10x1.50x147mm (x16)							
HBS131  (22-17014B) M10x1.25x100mm (x10)	JD340  (31-028789-00) JD566  HA5005  [0] (24-29252-00/0) JD5143  (31-028790-10)	JN973 (31-028483-00)	JJ453	HR800 	NA5187 (x2) 30x52x7mm, ACM (50-319492-00) NB818  40x56x7mm, ACM NF887  [3] 64x112.5x20mm, FPM (50-319393-00)		
HBS132  (22-17015B) M10x1.25x254mm (x10)	JA5007  JD273  (31-027729-00) (MLS)	HL701  (24-28782-00/0)	JJ535 (31-028781-00)	HR800 	NA5053 30x42x7mm, FPM (50-319488-00) NA5069 55x68x8mm, FPM (50-319515-00) NA5070  31x41x7mm, FPM (50-319524-00) NF888  [3] 93x139.7x12mm, FPM (50-319526-00)	HL5030 [245] 	
HBS132  (22-17015B) M10x1.25x254mm (x10)	JD271  (31-027450-10) (Metal) JD273  (31-027729-00) (MLS)	HL701  (24-28782-00/0)		HR800 	NA5053 30x42x7mm, FPM (50-319488-00) NA5069 55x68x8mm, FPM (50-319515-00) NA5070  31x41x7mm, FPM (50-319524-00) NF888  [3] 93x139.7x12mm, FPM (50-319526-00)	HL5030 [245]  KK5158 [45]	
HBS227  (22-17018B) M12x1.25x218mm (x10)	JD580  →02/00 JA5035  (31-029407-00) 02/00 → JD468  (31-028377-00) (MLS)	JP063		HR363 	NA5053 30x42x7mm, FPM (50-319488-00) NA5070  31x41x7mm, FPM (50-319524-00) NF888  [3] 93x139.7x12mm, FPM (50-319526-00)	HL5031 [245]  KL476 [70] KA845 [13] JR5001 [11]	



KW/PS

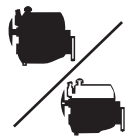

Model				Year Range	Cylinders	Power (KW/PS)	Injection System	Part Numbers	Accessories	
Lybra 1.9L JTD Diesel				09/00 → 05/01	4	82.00		47		
937 A2.000	1910	4	82.00	Direct Injection, SOHC	85/116 85-80/ 116- 109	AG7390 (MLS), 0.82mm (30-030144-00) AA5570 (MLS), 0.92mm, 1 Hole (30-029094-10) AA5580 (MLS), 1.02mm, 2 Holes (30-029095-10)			CA5560▲ (21-29093-21/0) → Eng.4081111 CC5561 Eng.4081111→	EE5181 (22-29832-01/0) FA5560▲ (20-29095-00/0)
AR 37101	1910	4	82.00							
Lybra 2.0L 20V				07/99 → 09/00	5	82.00		48		
182 B7.000	1998	5	82.00		113/154	BW320 (Fibre) (30-027452-00)			DW322 (21-27452-21/0)	
Lybra 2.0L 20V				09/00 →	5	82.00		49		
185 A8.000	1998	5	82.00		113/154	AA5590 (MLS), 0.49mm (30-029275-00)			CA5590 [169]	ED5960 (22-29778-00/0)
Lybra 2.4L JTD Diesel				07/99 → 09/00	5	82.00		50		
839 A5.000	2387	5	82.00	Direct Injection	99-96/ 135- 131	AY550 (MLS), 1.60mm (30-029020-00) AY560 (MLS), 1.70mm, 1 Hole (30-029021-00) AY570 (MLS), 1.80mm, 2 Holes (30-029022-00)			CY520▲ [106] (21-29020-20/0)	FY520▲ [106] (20-29020-00/0)
AR 32501	2387	5	82.00	Direct Injection, SOHC	100-99/ 136- 135					
Lybra 2.4L JTD Diesel				09/00 → 05/02	5	82.00		51		
839 A6.000	2387	5	82.00	Direct Injection, SOHC	103/140	AA5780 (MLS), 0.82mm (30-029266-00) AA5790 (MLS), 0.92mm (30-029282-00) AA5800 (MLS), 1.02mm (30-029283-00)			CA5780▲ (21-29266-20/0)	EA5780 (22-29266-00/0)
841C.000	2387	5	82.00	Direct Injection	110/150					
Musa 1.3L D Multijet Diesel				09/06 →	4	69.60		52		
199 A3.000	1248	4	69.60	Direct Injection, DOHC	66/90				CD5820▲	ED5820 FD5820▲
Musa 1.3L Multijet Diesel				10/04 →	4	69.60		53		
188 A9.000	1248	4	69.60	Direct Injection, DOHC	51/70	AD5800 (MLS), 0.72mm (30-029762-00) AD5810 (MLS), 0.82mm, 1 Hole (30-029763-00) AD5820 (MLS), 0.92mm, 2 Holes (30-029764-00)			CD5800▲ (21-29762-20/0) CD5810▲	ED5810 FD5810
Musa 1.4L				10/04 →	4	72.00		54		
843 A 1.000	1368	4	72.00		70/95	AG6220 (MLS) (30-030139-00) →04/06 AG7310 (MLS) (30-030140-00) 04/06 →			CG6220 (21-30139-00/0) →04/06 CG7310 (21-30140-00/0) 04/06 →	
Musa 1.4L				09/05 →	4	72.00		55		
350 A1.000	1368	4	72.00	Injection, SOHC	57-55/ 78-75	AG7380 (MLS) (30-030143-00)			CG7380 (21-30143-00/0)	
Musa 1.9L Multijet Diesel				10/04 →	4	82.00		56		
188 B2.000	1910	4	82.00	Direct Injection, SOHC		AG7390 (MLS), 0.82mm (30-030144-00) AA5570 (MLS), 0.92mm, 1 Hole (30-029094-10) AA5580 (MLS), 1.02mm, 2 Holes (30-029095-10)			CA5560▲ (21-29093-21/0) → Eng.4081111 CA5561▲ (21-29093-20/0) Eng.4081111→	EE5181 (22-29832-01/0)

HBS227 [22-17018B] M12x1.25x218mm (x10)	JA5035 (31-029407-00) JD580 JD468 (31-028377-00) (MLS)	JM5028 (31-029635-00) →Eng.4081110 JM5204 (50-029935-00) Eng.4081111 →		HR363	NA5053 30x42x7mm, FPM (50-319488-00) NA5070 31x41x7mm, FPM (50-319524-00) NF888 [3] 93x139.7x12mm, FPM (50-319526-00)	HL5031 [245] KL476 [70] JR5001 [11]	 AA5570, AA5580 AA5590 AA5780 AA5790 AA5800 AD5800 AD5810 AD5820 AY550, AY560, AY570 BW320 JA5035 JA5036 JD225 JD226 JD228 JD468 JD5412 JD580 JD581 JM5018 JM5028	JM5029 (31-029408-00) JD581 JD228 (31-027837-10)	HR363	NA5053 30x42x7mm, FPM (50-319488-00) NA5070 31x41x7mm, FPM (50-319524-00) NF888 [3] 93x139.7x12mm, FPM (50-319526-00)	HL5031 [245] KL477 [70] KA845 [13] JR5001 [11]	 JM5029 JP064	HBS257 [22-56010B] M12x1.25x218mm (x12)	JA5036 (31-029408-00) JD581 JD228 (31-027837-10)	JP064	HR354 [94]	HR800	NA5053 30x42x7mm, FPM (50-319488-00) NA5069 55x68x8mm, FPM (50-319515-00) NA5070 31x41x7mm, FPM (50-319524-00) NF888 [3] 93x139.7x12mm, FPM (50-319526-00)	HL5030 [245] KL477 [70] KA845 [13] HJ283 [39] KK5156 [45]	 HBS257 JA5036 JD228 JM5018	HBS257 [22-56010B] M12x1.25x218mm (x12)	JA5036 (31-029408-00) JD228 (31-027837-10)	JM5029 (31-030023-00)	HR363	NA5053 30x42x7mm, FPM (50-319488-00) NA5070 31x41x7mm, FPM (50-319524-00) NF888 [3] 93x139.7x12mm, FPM (50-319526-00)	HL5031 [245] KL477 [70] KA845 [13] JR5001 [11]	 HBS353 JD5411 JD5412 JD5413 (31-030027-00) (MLS)	JD5411 (50-030025-00) JD5412 JD5413 (31-030027-00) (MLS)	JM5259 (31-030023-00)	HR5088 (24-31952-10/0)	NA5223 40x52x7mm, FPM (50-319520-00) NA5230 78x100x9mm, PTFE (50-319522-00)	KK5646 [45]	 HBS353 JD5411 JD5412 JD5413 JD225 JD226 JD228 JD468 JD5412 JD580 JD581	HBS247 [22-17019B] M9x1.25x87mm (x10)						 HBS247	HBS052 [22-17006B] M9x1.25x95mm (x10)					 HBS052	HBS227 [22-17018B] M12x1.25x218mm (x10)	JA5035 (31-029407-00) JD468 (31-028377-00) (MLS)					 HBS227	JM5018 JM5028



KW/PS

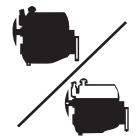

Phedra 2.0L D Multijet Diesel					07/06 →	57		CD5500▲	ED5500
Phedra 2.0L JTD Diesel					06/06 →				
RHK/RHR	1997	4	85.00	Direct Injection, DOHC					
Phedra 2.0L					09/02 →	58	AD5300 (MLS)	CD5300	
RFN(EW10J4)	1997	4	85.00	Injection, DOHC			RFN(EW10J4)		
Phedra 2.0L JTD Diesel					09/02 →	59	AD5490 (MLS), 1.25mm (30-029789-00) AD5500 (MLS), 1.30mm (30-029790-00) AD5510 (MLS), 1.35mm (30-029791-00) AD5520 (MLS), 1.40mm (30-029792-00)		
DW10ATED4 (RHW)	1998	4	85.00	Common Rail, SOHC	80/109				
Phedra 2.0L JTD Diesel					07/03 →	60			
DW10ATED4 (RHM)	1997	4	85.00	Direct Injection, DOHC	79/107				
Phedra 2.2L JTD Diesel					09/02 →	61	AD5490 (MLS), 1.25mm (30-029789-00) AD5500 (MLS), 1.30mm (30-029790-00) AD5510 (MLS), 1.35mm (30-029791-00) AD5520 (MLS), 1.40mm (30-029792-00)	CD5490▲ (21-29789-20/0)	ED5490 (22-29789-00/0)
4HW(DW12ATED4)	2179	4	85.00	Direct Injection, DOHC					
Phedra 3.0L V6					09/02 →	62			
ES9 J4S	2946	6	87.00	Injection, V6					
Prisma 1.3L					01/83 →02/92	63			
	1301	4			58/79				
Prisma 1.5L					09/85 →02/92	64			
831 B1.048	1498	4	86.40		55/75				
138 C2.048	1498	4	86.40	Injection, SOHC					
Prisma 1.5L					08/86 →02/92	65	BP860 (Fibre) (30-025893-10)	DP871 (21-25894-22/0) →Eng.5750056 DJ851▲ Eng.5750056→ DP861 (21-25893-22/0) Eng.5750056→	GP861 (20-25893-02/0)
831 B1.000	1498	4	86.40		59-63/ 80-86				
Prisma 1.6L i.e.					05/86 →12/89	66	BT410 (Fibre) BT440 (Fibre) (30-026647-30)	DT411 [12] (21-25413-23/0)	GT411 [12]
831 B7.000	1585	4	84.00		80/109				
Prisma 1.9L D Diesel					01/83 →02/92	67	BR690 (Graphite), 1.80mm, 1 Notch (30-025167-10) BR700 (Graphite), 1.95mm, 2 Notches (30-026298-10)	DT290▲ (21-25950-21/0)	
831 D.000	1929	4	82.60		62/84				
Thema 2000 16V					08/92 →12/93	68	BT440 (Fibre) (30-026647-30)	DT448	GT448
834 F1.000	1995	4	84.00		102/139				

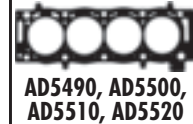
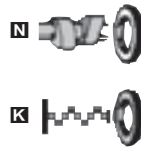
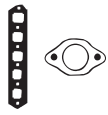

BP860



BR690, BR700



BT410



BT440



JA757



JC662



JD151



JD153



JN643



JN645



JN928



JJ298



JJ413



KW/PS



Thema 2000 16V Turbo				10/92 → 07/94	69	BT440 (Fibre) (30-026647-30)	DT442 [12] (21-26647-26/0)	FB5720 ▲■ (20-29319-00/0)
834 F2.000	1995	4	84.00		136/185			
Thema 2000 16V Turbo				12/88 → 06/90	70	BT440 (Fibre) (30-026647-30)	DT442 [12] (21-26647-26/0)	
834 C1.000	1995	4	84.00		136/185			
Thema 2000 i.e.				09/88 → 05/92	71	BT410 (Fibre)	DT420 (21-25413-21/0)	
Thema 2000 i.e.				03/86 → 09/88		BT420 (Fibre) (30-025413-10)	→ Eng.1033482 DT413 Eng.1033482 →	
834 B.048/834 B1.000	1995	4	84.00	Injection	88/120			
Thema 2000 i.e.				09/87 → 05/92	72	BT420 (Fibre) (30-025413-10)	DT413	
834 B.146	1995	4	84.00	Injection	88/120	BT440 (Fibre) (30-026647-30)		
Thema 2000 i.e. 16V				05/88 → 08/92	73	BT440 (Fibre) (30-026647-30)	DT441 (21-26647-21/0)	GT441 (20-26647-00/0)
834 B2.000/834 B2.246	1995	4	84.00	i.e.	110/150			
Thema 2000 i.e. 16V Turbo				12/88 → 06/90	74	BT440 (Fibre) (30-026647-30)	DT442 [12] (21-26647-26/0)	GT442 [12]
834 C1.000	1995	4	84.00		136/185			
Thema 2000 i.e. Turbo				11/84 → 12/87	75	BT420 (Fibre) (30-025413-10)	DT412 [12] DT420 (21-25413-21/0)	GP688
834 C.000	1995	4	84.00		121/165	BT440 (Fibre) (30-026647-30)	→ Eng.1033481	
Thema 2000 i.e. Turbo				07/86 → 05/90	76	BT410 (Fibre) Eng.1033482 →	DT413 Eng.1033482 →	GP688
834 C.146	1995	4	84.00		121/165			
Thema 2500 Turbo D Diesel				11/84 → 09/88	77	BP270 (Fibre), 1.65mm (30-026650-20)	DP273 ▲ (21-26100-21/0)	FB5720 ▲■ (20-29319-00/0)
8144.91	2445	4	93.00		76/103	BR090 (Fibre), 1.80mm [161] (30-026651-20)		
Thema 2.5L TD Diesel				01/92 →	78	AY290 (Fibre), 1.60mm [112] (30-027426-00)	DT752 ▲ (21-28648-20/0)	GT751 ▲
8140.97.2200/ 8140.97.2500	2499	4	93.00	Sofim, Turbo Intercooled	85/116	AY300 (Fibre), 1.70mm [112] (30-026654-20)		
Thema 2500 Turbo DS Diesel				06/88 → 05/92	79	AY310 (Fibre), 1.80mm [112] (30-026655-20)	DT752 ▲ (21-28648-20/0)	GT751 ▲
8144.97	2499	4	93.00		85/115	AY290 (Fibre), 1.60mm [112] (30-027426-00)		
Thema 2500 Turbo DS Diesel				05/88 → 07/92	80	AY300 (Fibre), 1.70mm [112] (30-026654-20)	DP273 ▲ (21-26100-21/0)	GT750 ▲ (20-26100-00/0)
8144.97 8144.97S	2499 2500	4 4	93.00 93.00	Indirect Injection	85/115 77/105	AY310 (Fibre), 1.80mm [112] (30-026655-20)		

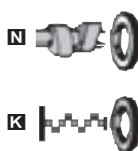
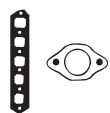

AY290, AY300,
AY310



BP270, BR090



BT410



BT440, BT420



JC054



JC055



JD151



JD153



JN928



JN969



JJ298



JJ413



JJ549



HBS093 (22-17005B) M10x1.25x172mm (x10)							
HBS093 (22-17005B) M10x1.25x172mm (x10)							
HBS092 (22-17003B) M10x1.25x115mm (x10)				HR363	NB742 30x43x8mm, ACM (50-319408-00) NB732 74x90x10mm, FPM NA5062 74x90x10mm, ACM		
HBS092 (22-17003B) M10x1.25x115mm (x10)							
HBS093 (22-17005B) M10x1.25x172mm (x10)	JD153 (31-027321-00) JD151 (31-027331-00)	JN928 [102] (50-027319-00)	JJ298 JJ413 (31-027315-00)	HR800	NA5053 30x42x7mm, FPM (50-319488-00) NB742 30x43x8mm, ACM (50-319408-00) NB732 74x90x10mm, FPM	LB175 [70] KT465 [54] JR749 [11] JS081 [11] KT639 [11] LV585 [45] OK473 [160]	
HBS093 (22-17005B) M10x1.25x172mm (x10)	JD153 (31-027321-00) JD151 (31-027331-00)	JN928 [102] (50-027319-00)	JJ298 JJ413 (31-027315-00)	HR800	NA5053 30x42x7mm, FPM (50-319488-00) NB742 30x43x8mm, ACM (50-319408-00) NB732 74x90x10mm, FPM	LB175 [70] KT465 [54] JR749 [11] JS081 [11] KT639 [11] LV585 [45] OK473 [160]	
HBS092 (22-17003B) M10x1.25x115mm (x10)							
HBS011 (22-51004B) M12x1.25x160mm (x10) M12x1.25x119mm (x12)				HR602 24-30670-61/0			
HBS011 (22-51004B) M12x1.25x160mm (x10) M12x1.25x119mm (x12)	JC054 (31-024274-10) JC055 (31-025031-10)	JN969 (50-027678-00)	JJ549 (31-028788-00)				
HBS011 (22-51004B) M12x1.25x160mm (x10) M12x1.25x119mm (x12)				HR602 24-30670-61/0 HR781	NF853 100x118x10mm, FPM (50-307096-70)		
HBS011 (22-51004B) M12x1.25x160mm (x10) M12x1.25x119mm (x12)				HR602 24-30670-61/0	NP068 55x70x8mm, FPM (50-303186-00) NP068 55x70x8mm, FPM (50-303186-00)		



KW/PS



Model		Fuel		Period		Power	Code	Notes	Accessories
Thema 2500 Turbo DS		Diesel		05/92 → 07/94		81	AY290 (Fibre), 1.60mm [112] (30-027426-00) AY300 (Fibre), 1.70mm [112] (30-026654-20) AY310 (Fibre), 1.80mm [112] (30-026655-20)		
8144.97 Y	2499	4	93.00			85/115			
Thema 2500 Turbo DS		Diesel		09/92 → 04/97		82	AY290 (Fibre), 1.60mm [112] (30-027426-00) AY300 (Fibre), 1.70mm [112] (30-026654-20) AY310 (Fibre), 1.80mm [112] (30-026655-20)	DT752▲ (21-28648-20/0)	GT751▲
8144.97 Y	2499	4	93.00			85/115			
Thema 3000 V6				08/92 → 07/94		83	BW260 (Fibre) ■ (30-025873-20)		
834 F.000	2959	6	93.00			126/171			
Thesis 2.0L Turbo				07/02 →		84	AD5960 (MLS) (30-029778-00)	CD5960 (21-29778-20/0)	ED5960 (22-29778-00/0)
841E.000	1998	5	82.00	Injection, DOHC					
Thesis 2.4L D Multijet		Diesel		04/06 →		85			
841 P.000	2387	5	82.00	Direct Injection, DOHC		136/185			
Thesis 2.4L				07/02 →		86			
841D.000	2446	5	83.00			125/170			
Thesis 2.4L JTD		Diesel		07/02 →		87	AA5780 (MLS), 0.82mm (30-029266-00) AA5790 (MLS), 0.92mm (30-029282-00) AA5800 (MLS), 1.02mm (30-029283-00)	CA5780▲ (21-29266-20/0)	EA5780 (22-29266-00/0)
841C.000	2387	5	82.00	Direct Injection		110/150			
Thesis 2.4L JTD		Diesel		05/03 →		88	AD5910 (MLS), 0.82mm (30-029773-00) AD5920 (MLS), 0.92mm (30-029774-00) AD5930 (MLS), 1.02mm (30-029775-00)	CD5910 (21-29773-20/0)	ED5910 (22-29773-00/0)
841 G.000	2387	5	82.00	Direct Injection, DOHC		129/175			
Thesis 3.0L V6				07/02 →		89	BT380 (Fibre), 1.65mm ■ (30-027519-00) → Eng. 60548751 AY640 (Fibre), 1.65mm ■ (30-027518-10)	CY640 (21-27518-20/0)	FY640
841A.000	2959	6	93.00	Injection, DOHC, V6					
Trevi 2000 Volumex				08/83 → 05/85		90	BK540 (Fibre)		
828 B7.000	1995	4	84.00			99/135			
Y 1.1L				11/95 → 09/03		91	BP280 (Fibre), 1.65mm (30-026046-30) BV940 (Fibre), 2.00mm (30-028799-00)	CV940 [170] (21-28799-21/0) DV675 (21-27185-00/0)	GP285
176 B2.000	1108	4	70.00	SPI		40/55/ 54/75			
Y 1.2L				03/96 → 09/03		92	AE5240 (MLS) (30-029844-00) AE5550 (Fibre) [249] (30-029928-00) BV670 (Fibre) (30-027185-00)	DV672 [163] (21-27185-22/0)	EV670 (22-27185-00/0)
188 A4.000/840 A3.000	1242	4	70.80	SPI		44/60			











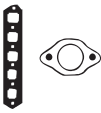

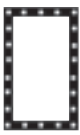

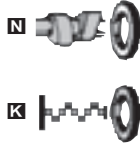

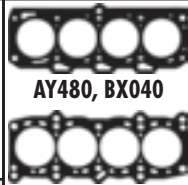



































HBS011 (22-51004B) M12x1.25x160mm (x10) M12x1.25x119mm (x12)			JJ549 (31-028788-00)				 AA5780	 JD5386
HBS011 (22-51004B) M12x1.25x160mm (x10) M12x1.25x119mm (x12)			JJ549 (31-028788-00)	HR602 24-30670-61/0	 NP068 55x70x8mm, FPM (50-303186-00) NP068 55x70x8mm, FPM (50-303186-00)		 AA5790	 JF145
HBS272 (22-53016B) M10x1.50x147mm (x16)	JD222 (31-027279-00) JD223 (31-027287-00)	JN808 (31-027281-00) JN807 (31-027280-00)		HR815	 NA5068		 AD5960	 JM5019
HBS133 (22-17016B) M10x1.25x254mm (x12)							 AY290, AY300, AY310	 JN807
HBS257 (22-56010B) M12x1.25x218mm (x12)							 AY640	 JN808
HBS463 (22-26020B) M11x1.5x141mm (x8)	JD5386 (x8) (31-029993-00)			HR5055 24-30704-45/0	 NA5131 45x67x8mm, PTFE (50-319436-00) NA5168 93x114x11.5mm, PTFE (50-319437-00)		 BK540	 JP070
HBS257 (22-56010B) M12x1.25x218mm (x12)	JA5036 (31-029408-00) JD228 (31-027837-10)	JM5029		HR363	 NA5053 30x42x7mm, FPM (50-319488-00) NA5070 31x41x7mm, FPM (50-319524-00) NF888 [3] 93x139.7x12mm, FPM (50-319526-00)	HL5031 [245] KL477 [70] KA845 [13] JR5001 [11]	 BP280, BV940	 JP071
HBS371 (22-17027B) M12x1.25x255mm (x12)							 BT380	 JJ549
HBS272 (22-53016B) M10x1.50x147mm (x16)		JP071 JP070		HR800	 NA5163 (x4) 32x47x10mm, FPM NA5068		 BV670	
				HR596		KV122 [56]	 BW260	
HBS052 (22-17006B) M9x1.25x95mm (x10)	JD148 (31-025907-10) JD5375 (31-029968-00) JF145 (MLS)	JN667 (50-026094-00)		HR599 (24-31919-10/0)	 NA5053 30x42x7mm, FPM (50-319488-00) NB815 23x35x7mm, FPM (50-319523-00) NA5061 74x88x8mm, FPM	HL5024 [245] JR673 [11]	 JA5010	
HBS052 (22-17006B) M9x1.25x95mm (x10)	JA5010 JD5375 (x2) (31-029968-00)	JM5019	HR354 [94]	HR599 (24-31919-10/0)	 NA5053 30x42x7mm, FPM (50-319488-00) NB815 23x35x7mm, FPM (50-319523-00) NA5061 74x88x8mm, FPM	HL5024 [245] KA5032 [53]	 JA5036	
							 JD148	
							 JD222	
							 JD223	
							 JD228	
							 JD5375	



KW/PS



Y 1.2L 16V 10/00 → 09/03 93					AD5830 (MLS) (30-029765-00) BY380 (Fibre), 1.65mm (30-028024-30)	DY383 (21-28024-23/0) → Eng.0616936 CE5181 (21-29832-21/0) Eng.0616937 →	EE5180 (22-29832-00/0) GY383 (20-28024-03/0)
188 A5.000	1242	4	70.80	Injection	59/80		
Y 1.2L 16V 04/97 → 09/03 94					AD5830 (MLS) (30-029765-00) BY380 (Fibre), 1.65mm (30-028024-30)	DY382 (21-28024-22/0) → Eng.0616936 CE5180 (21-29832-20/0) Eng.0616937 →	GY383 (20-28024-03/0)
176 B9.000	1242	4	70.80	Injection	63/86		
Y 1.4L 12V 03/96 → 09/03 95					AY480 (Fibre) [249] BX040 (Fibre), 1.20mm (30-028380-00)	DX040 (21-28380-20/0)	GX041
840 A2.000/840 A4.000	1370	4	82.00	i.e.	58/79		
Y10 1.0L Fire 03/85 → 06/89 96					BP280 (Fibre), 1.65mm (30-026046-30) BV940 (Fibre), 2.00mm (30-028799-00)	DV675 (21-27185-00/0)	GP282 [171] (20-26046-00/0)
156 A 2.000	999	4	70.00	Injection, SOHC			
Y10 1.0L Fire 03/85 → 02/90 97					BP280 (Fibre), 1.65mm (30-026046-30) BV940 (Fibre), 2.00mm (30-028799-00)	DV675 (21-27185-00/0)	GP282 [171] (20-26046-00/0)
Y10 1.0L Fire 4WD 12/87 → 02/90							
156 A 2.000	999	4	70.00	Injection, SOHC			
Y10 1.0L Fire 4WD 12/86 → 02/89 98					BP280 (Fibre), 1.65mm (30-026046-30) BV940 (Fibre), 2.00mm (30-028799-00)	CV940 [170] (21-28799-21/0) DV675 (21-27185-00/0)	GP282 [171] (20-26046-00/0)
156 A 2.100	999	4	70.00	Injection, SOHC	32/44		
Y10 1.0L Fire 4WD 12/87 → 02/92 99					BP280 (Fibre), 1.65mm (30-026046-30) BV940 (Fibre), 2.00mm (30-028799-00)	DV675 (21-27185-00/0)	GP282 [171] (20-26046-00/0)
156 A2.246	999	4	70.00	Injection, SOHC	32/45		
Y10 1.0L Turbo 03/85 → 02/89 100					BP290 (Fibre) (30-025345-10)	DP294	
156 A 1.000	1049	4	76.00	Carburettor			
Y10 1.1L Avenue 01/95 → 12/95 101					BP280 (Fibre), 1.65mm (30-026046-30) BV940 (Fibre), 2.00mm (30-028799-00)	CV940 [170] (21-28799-21/0) DV675 (21-27185-00/0)	GP285
Y10 1.1L Avenue 4WD 01/95 → 12/95							
176 B2.000	1108	4	70.00	SPI	40/55/ 54/75		
Y10 1.1L i.e 08/89 → 06/92 102					BP280 (Fibre), 1.65mm (30-026046-30) BV940 (Fibre), 2.00mm (30-028799-00)	DV675 (21-27185-00/0)	GP282 [171] (20-26046-00/0)
Y10 1.1L i.e 4WD 08/89 → 06/92							
156 C.000	1108	4	70.00	Injection, SOHC	42/57		
Y10 1.3L i.e. Fire 11/87 → 05/93 103					BP290 (Fibre) (30-025345-10)	DP292 [12] (21-25345-23/0)	
156 B.000	1301	4	76.10	Injection, SOHC	56-53/ 76-72		







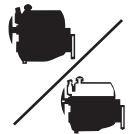



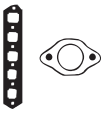

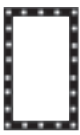

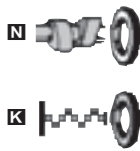





















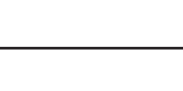















									
HBS247  (22-17019B) M9x1.25x87mm (x10)	JA5005  (50-029899-00) (Rubber) JA5006  (31-029900-00)	JM5176 (50-029831-00)		HR814  (50-319374-00)	NA5058 40x55x7mm, FPM NA5057 27x37x7mm, FPM LK5001  [3] 74x187.5x17mm, FPM (50-319456-00)	KA5032 [53]		AY480, BX040 BP280, BV940 BP290 BY380	JJ078
HBS247  (22-17019B) M9x1.25x87mm (x10)	JD464  JD465 	JM5176 (50-029831-00)		HR814  (50-319374-00)	NA5058 40x55x7mm, FPM NA5057 27x37x7mm, FPM NA5061 74x88x8mm, FPM	JR673 [11]		JA5005 JA5006 JD148 JD342 JD343	
HBS130  (22-17013B) M10x1.25x163mm (x10)	JD342  (31-028783-00) JD343  (31-027836-20)	JN972 (50-028784-00)	HR354 [94]	HR800 	NA5053 30x42x7mm, FPM (50-319488-00) NA5070 31x41x7mm, FPM (50-319524-00) NF888  [3] 93x139.7x12mm, FPM (50-319526-00)	HL5031 [245] 		JA5005 JA5006 JD148 JD342 JD343	
HBS052  (22-17006B) M9x1.25x95mm (x10)	JD148  (31-025907-10) JD5375  (x2) (31-029968-00) JF145  (MLS)	JN667 (50-026094-00)	HR354 [94]	HR599  (24-31919-10/0)	NA5053 30x42x7mm, FPM (50-319488-00) NB815 23x35x7mm, FPM (50-319523-00) NB814 70x88x8mm, FPM (50-306350-50)	HL5024 [245]  LV695 [53] JR673 [11] LB177 [46]		JD148 JD342 JD343	
HBS052  (22-17006B) M9x1.25x95mm (x10)	JD5375  (31-029968-00)							JD464 JD465 JD5155 JD5375	
HBS052  (22-17006B) M9x1.25x95mm (x10)	JD148  (31-025907-10) JD5375  (x2) (31-029968-00) JF145  (MLS)	JN667 (50-026094-00)	HR354 [94]	HR599  (24-31919-10/0)	NA5053 30x42x7mm, FPM (50-319488-00) NB815 23x35x7mm, FPM (50-319523-00) NB814 70x88x8mm, FPM (50-306350-50)	HL5024 [245]  KA5032 [53] JR673 [11]		JD464 JD465 JD5155 JD5375 JF145	
HBS052  (22-17006B) M9x1.25x95mm (x10)	JD148  (31-025907-10) JD5375  (x2) (31-029968-00) JF145  (MLS)	JN667 (50-026094-00)		HR599  (24-31919-10/0)	NA5053 30x42x7mm, FPM (50-319488-00) NB815 23x35x7mm, FPM (50-319523-00) NB814 70x88x8mm, FPM (50-306350-50)	HL5024 [245]  KA5032 [53] LV695 [53] HJ274 [39]  HJ280 [39]  JR673 [11] LB177 [46]		JF145 JM5176	
	JD5155 (31-029308-00)	JN587	JJ078			JR556 [11]		JM5176	
HBS052  (22-17006B) M9x1.25x95mm (x10)	JD148  (31-025907-10) JD5375  (x2) (31-029968-00) JF145  (MLS)	JN667 (50-026094-00)	HR354 [94]	HR599  (24-31919-10/0)	NA5053 30x42x7mm, FPM (50-319488-00) NB815 23x35x7mm, FPM (50-319523-00) NA5061 74x88x8mm, FPM	HL5024 [245]  JR673 [11]		JN587 JN667	
HBS052  (22-17006B) M9x1.25x95mm (x10)	JD5375  (31-029968-00)							JN667 JN972	



KW/PS



Ypsilon 1.2L					10/03 →	104	AE5240 (MLS) (30-029844-00) AE5550 (Fibre) [249] (30-029928-00) BV670 (Fibre) (30-027185-00)	DV672 [163] (21-27185-22/0)	EE5242
188 A4.000	1242	4	70.80	SPI		44/60			
Ypsilon 1.2L					10/03 →	105	AD5830 (MLS) (30-029765-00) BY380 (Fibre), 1.65mm (30-028024-30)	DY383 (21-28024-23/0) →Eng.0616936 CE5181 (21-29832-21/0) Eng.0616937 →	GY383 (20-28024-03/0)
188 A5.000	1242	4	70.80	Injection		59/80			
Ypsilon 1.3L D Multijet Diesel					09/06 →	106	AD5800 (MLS), 0.72mm (30-029762-00) AD5810 (MLS), 0.82mm, 1 Hole (30-029763-00) AD5820 (MLS), 0.92mm, 2 Holes (30-029764-00)	CD5810▲	ED5810 FD5810
199 A2.000	1248	4	69.60	Direct Injection, DOHC					
Ypsilon 1.3L D Multijet Diesel					09/06 →	107	AD5800 (MLS), 0.72mm (30-029762-00) AD5810 (MLS), 0.82mm, 1 Hole (30-029763-00) AD5820 (MLS), 0.92mm, 2 Holes (30-029764-00)	CD5810▲	FD5820▲
199 A3.000	1248	4	69.60	Direct Injection, DOHC		66/90			
Ypsilon 1.3L JTD Diesel					10/03 →	108	AD5800 (MLS), 0.72mm (30-029762-00) AD5810 (MLS), 0.82mm, 1 Hole (30-029763-00) AD5820 (MLS), 0.92mm, 2 Holes (30-029764-00)	CD5800▲ (21-29762-20/0) CD5810▲	ED5810 FD5810
188 A9.000	1248	4	69.60	Direct Injection, DOHC		51/70			
Ypsilon 1.4L					10/03 →	109	AG6220 (MLS) (30-030139-00) →04/06 AG7310 (MLS) (30-030140-00) 04/06 →	CG6220 (21-30139-00/0) →04/06 CG7310 (21-30140-00/0) 04/06 →	
843 A 1.000	1368	4	72.00			70/95			
Ypsilon 1.4L					02/06 →	110	AG7380 (MLS) (30-030143-00)	CG7380 (21-30143-00/0)	
350 A1.000	1368	4	72.00	Injection, SOHC		57-55/ 78-75			
Zeta 2.0L 16V					05/98 →07/00	111	AY070 (Fibre) (30-029744-00)		
XU10 (RFV)	1998	4	86.00	Injection, DOHC		99/135			
Zeta 2.0L 16V					07/00 →09/02	112	AD5300 (MLS) RFN(EW10J4)		
RFN	1997	4	85.00	Injection, DOHC					

								
HBS052  (22-17006B) M9x1.25x95mm (x10)	JA5010  JD5375  (x2) (31-029968-00)	JM5019	HR354 [94]		NA5053 30x42x7mm, FPM (50-319488-00) NB815  23x35x7mm, FPM (50-319523-00) NA5061  74x88x8mm, FPM	HL5024 [245]  KA5032 [53]		 AD5800  AD5810  AD5820  AE5240  AY070  BV670  BY380  JA5005  JA5006  JA5010  JD536  JD5375  JD5412  JM5019  JM5176
HBS247  (22-17019B) M9x1.25x87mm (x10)	JA5005  (50-029899-00) (Rubber) JA5006  (31-029900-00)	JM5176 (50-029831-00)		HR814  (50-319374-00)	NA5058 40x55x7mm, FPM NA5057  27x37x7mm, FPM LK5001  [3] 74x187.5x17mm, FPM (50-319456-00)	KA5032 [53]		
HBS353  (22-17025B) M10x1.25x119mm (x10)								
HBS353  (22-17025B) M10x1.25x119mm (x10)								
HBS353  (22-17025B) M10x1.25x119mm (x10)	JD5411  (50-030025-00) JD5412   (50-030026-00) JD5413  (31-030027-00) (MLS)	JM5259 (31-030023-00)		HR5088  (24-31952-10/0)	NA5223  40x52x7mm, FPM (50-319520-00) NA5230  78x100x9mm, PTFE (50-319522-00)	KK5646 [45]		
HBS247  (22-17019B) M9x1.25x87mm (x10)								
HBS247  (22-17019B) M9x1.25x87mm (x10)								
HBS087  (22-15013B) M12x1.50x110mm (x10) →Eng.08581 HBS278  (22-53019B) M12x1.50x110mm (x10) Eng.08582 →	JD536 							
HBS259  (22-53010B) M11x1.50x144.5mm (x10)	JD5833 	JM5283  JM5139 			NA5256  40x55x6.5mm			



KW/PS



Zeta 2.0L JTD Diesel				09/99 → 09/02	113			
DW10ATED4 (RHW)	1998	4	85.00	Common Rail, DOHC	80/109	AC5020 (MLS), 1.35mm, 2 Holes (30-029478-00) ☞ 0.605 → 0.655mm AC5031 (MLS), 1.40mm, 3 Holes (30-029479-10) ☞ 0.655 → 0.705mm AC5040 (MLS), 1.45mm, 4 Holes (30-029480-00) ☞ 0.705 → 0.755mm AC5051 (MLS), 1.50mm, 5 Holes (30-029481-10) ☞ 0.755 → 0.83mm	CC5010▲ (21-29484-20/0)	
Zeta 2.0L Turbo				05/95 → 09/02	114			
RGX (XU 10)	1998	4	86.00		108/147	BY310 (Fibre), 1.25mm (30-028761-00) BY320 (Fibre), 1.45mm [34]	DY310▲ (21-25204-25/0)	ES820 (22-25198-03/0)
Zeta 2.1L TD Diesel				05/96 → 09/99	115			
P 8 C	2088	4	85.00	SOHC	80/109	BY941 (MLS), 1.52mm (30-027543-20) ☞ 0.65 → 0.76mm BY950 (MLS), 1.57mm (30-027544-10) ☞ 0.77 → 0.81mm BY961 (MLS), 1.62mm (30-028712-10) ☞ 0.82 → 0.86mm BY970 (MLS), 1.67mm [68] (30-028713-00) BY981 (MLS), 1.72mm (30-028714-10) ☞ 0.92 → 0.96mm	DV150▲ (21-27540-20/0)	EV150 (22-25198-02/0)

HBS261 (22-53014B) M12x1.50x131mm (x10)	JD5191 JD5190	JM5087 JM5141 (50-030271-00)		HR5046 (x2)	NA5035 27x47x7mm, FPM (50-319474-00) NA5191 42x62x7mm, PTFE (50-319500-00) NA5192 90x110x7mm, PTFE (50-319501-00)	HL5016 [245]	 AC5020, AC5040 BY310, BY320 BY950, BY970 HA512 JD230 JD529 JN547 JJ283
HBS084 (22-15005B) M12x1.50x123mm (x10)	HA512	JN547 (50-025204-10)	JJ283 [6] (31-025198-10)	HR569 24-30667-00/0	NF817 36x50x7mm, FPM (50-319112-00) NA5191 42x62x7mm, PTFE (50-319500-00) NA5192 90x110x7mm, PTFE (50-319501-00)	NF825 [38] NF824 [38] KA611 [13]	
HBS125 (22-15007B) M12x1.50x150.5mm (x10)	JD529 (31-027540-00) JD230						



CC



9



CC



9

10J	Diesel	2286	4	90.47	5
11 A	Diesel	2376	4		25
11 D	Petrol	3528	8		32
11 L (200Tdi)	Diesel	2495	4	90.50	13
12 L (200Tdi)	Diesel	2496	4	90.50	28
12J	Diesel	2494	4	90.47	11
12J	Diesel	2494	4	90.47	7
16 L (300Tdi)	Diesel	2495	4	90.50	13
17H	Petrol	2494	4	90.47	6
17H	Petrol	2495	4	90.50	10
17L (300Tdi)	Diesel	2496	4	90.47	26
18K4F	Petrol	1796	4	80.00	21
19J	Diesel	2494	4	90.47	8
2.25	Petrol	2286	4	90.47	1
2.25D	Diesel	2286	4	90.47	2
20 T2N (L Series)	Diesel	1994	4	84.45	22
20T4H (T Series)	Petrol	1994	4	84.45	14
20T4H (T Series)	Petrol	1994	4	84.45	15
22 D	Petrol	3531	8	88.90	17
23 L (300Tdi)	Diesel	2495	4	90.50	13
24 D	Petrol	3528	8		31
25 6T (BMW)	Diesel	2497	6		27
25 D	Petrol	3528	8		31
25 K4F	Petrol	2497	6	80.00	24
2L	Petrol	2286	4	90.47	4
3.5V8	Petrol	3528	8	88.86	3
3.5V8	Petrol	3528	8	88.86	9
31 D	Petrol	3528	8		31
35 D	Petrol	3950	8	94.00	18
35 D	Petrol	3950	8	94.00	33
36 D	Petrol	3950	8	94.00	18
36 D	Petrol	3950	8	94.00	33
37 D	Petrol	3950	8	94.00	33
38 D	Petrol	3950	8	94.00	33
389F	Petrol	3532	8	88.86	30
40 D	Petrol	4275	8		36
42 D	Petrol	3947	8		34
44D	Petrol	3950	8	94.00	35
46 D	Petrol	4553	8		38
48D	Petrol	4554	8	94.00	38
4L	Petrol	2286	4	90.47	4
AJ41	Petrol	4394	8	88.00	20
AJ41	Petrol	4394	8	88.00	37
M47D20R	Diesel	1951	4	84.00	23
TD5	Diesel	2495	5	84.45	12
TD5	Diesel	2495	5	84.45	16











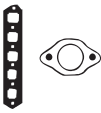

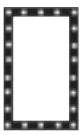

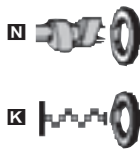

























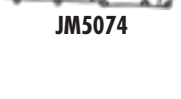







































































































































































































LAND ROVER



KW/PS



88/109 2.3L		09/63 → 12/86			1	BN600 (Fibre)	CD770 [121] DN600	ED770 [12] →1980 ED771 [12] 1980 → FD770 [12] →1980
2.25	2286	4	90.47		51/69			
88/109 2.3L D Diesel		09/63 → 12/86			2	AG210 (Fibre) [121] BM850 (Fibre) (30-027588-00)	CG210 [121]	EG210 [12][183] EG212 [12][185] FG210 [12][183]
2.25D	2286	4	90.47		46/63			
88/109 3.5L		01/80 → 12/83			3	AB5480 (Fibre) (x2) [188] AG910 (Steel) (x2)	CG913	EG914
3.5V8	3528	8	88.86	Carburettor	68/92			
90/110 2.3L		01/83 → 08/86			4	BN600 (Fibre)	CD770 [121] DN600	ED771 [12]
2L/4L	2286	4	90.47					
90/110 2.3L D Diesel		01/79 → 12/84			5	AG210 (Fibre) [121] BM850 (Fibre) (30-027588-00)	CG210 [121]	EG212 [12][185]
10J	2286	4	90.47	5 Main Bearing Crankshaft				
90/110 2.5L		09/85 → 07/90			6	BN600 (Fibre)	DN600	ED771 [12]
17H	2494	4	90.47		62/84			
90/110 2.5L D Diesel		01/84 → 12/90			7	BM850 (Fibre) (30-027588-00)	DM850 (21-27588-20/0)	EM850 (22-27589-00/0)
12J	2494	4	90.47	Indirect Injection				
90/110 2.5L TD Diesel		09/86 → 07/90			8	BM850 (Fibre) (30-027588-00)	DM852	EM852
19J	2494	4	90.47		63/86			
90/110 3.5L V8		09/83 → 07/90			9	AB5480 (Fibre) (x2) [188] AG910 (Steel) (x2)	CG913	EG914
3.5V8	3528	8	88.86	Carburettor	100/136			
Defender 2.5L		01/90 →			10	BN600 (Fibre)	DN600	ED771 [12]
17H	2495	4	90.50	OHV				
Defender 2.5L D Diesel		01/90 →			11	BM850 (Fibre) (30-027588-00)	DM850 (21-27588-20/0)	EM850 (22-27589-00/0)
12J	2494	4	90.47	Indirect Injection				
Defender 2.5L Td5 4WD Diesel		06/98 →			12	AB5900 (MLS), 1.20mm, 2 Holes (30-029439-00) AB5910 (MLS), 1.27mm, 1 Hole (30-029440-00) AB5920 (MLS), 1.35mm, 3 Holes (30-029441-00)	CB5900 [238] (21-29442-20/0) → Ch.1A736339 CB5901 [239] (21-29443-20/0) Ch.2A736340 →	EB5900 [12] (22-29444-00/0)
TD5	2495	5	84.45		90/122			

									
		JA323 →1980	JM356	JH409 (31-027589-00)	HR635  1968 →	 NB849  48.7x63.5x8mm, FPM (50-319467-00)  NA987  [183] 63.5x83.4x7.92mm, NBR  NZ997  [184][185]  NB848  [185] 100x120x11mm, PTFE		 AB5480  AB5900, AB5910, AB5920  AG210  AG910  BM850  BN600  JA323  JA5075  JA5076  JB792  JB894  JC882  JM350  JM356  JM483  JM5034  JM5074	 JH409  JH434  JH5014
		JC882	JM350	JH409 (31-027589-00)	HR635  1968 →	 NB849  48.7x63.5x8mm, FPM (50-319467-00)  NA987  [183] 63.5x83.4x7.92mm, NBR  NZ997  [183][184]  NB848  [185] 100x120x11mm, PTFE		 AB5900, AB5910, AB5920  AG210  AG910  BM850  BN600  JA323  JA5075  JA5076  JB792  JB894  JC882  JM350  JM356  JM483  JM5034  JM5074	 JH409  JH434  JH5014
		JB894  JB792  (x8)	JM483 (x2) (31-029717-00)	JH434	HR5052 	 NB849  48.7x63.5x8mm, FPM (50-319467-00)  NB291  82.6x98.7x12.7mm, MVQ	NA448 [2] 	 AB5900, AB5910, AB5920  AG210  AG910  BM850  BN600  JA323  JA5075  JA5076  JB792  JB894  JC882  JM350  JM356  JM483  JM5034  JM5074	 JH409  JH434  JH5014
		JC882	JM350	JH409 (31-027589-00)	HR635 	 NB849  48.7x63.5x8mm, FPM (50-319467-00)  NB848  100x120x11mm, PTFE		 AB5900, AB5910, AB5920  AG210  AG910  BM850  BN600  JA323  JA5075  JA5076  JB792  JB894  JC882  JM350  JM356  JM483  JM5034  JM5074	 JH409  JH434  JH5014
		JC882	JM356	JH409 (31-027589-00)	HR635 	 NB849  48.7x63.5x8mm, FPM (50-319467-00)  NB848  100x120x11mm, PTFE		 AB5900, AB5910, AB5920  AG210  AG910  BM850  BN600  JA323  JA5075  JA5076  JB792  JB894  JC882  JM350  JM356  JM483  JM5034  JM5074	 JH409  JH434  JH5014
		JC882	JM350	JH409 (31-027589-00)	HR635 	 NB775 40x52x7mm, FPM  NB849  48.7x63.5x8mm, FPM (50-319467-00)  NB848  100x120x11mm, PTFE		 AB5900, AB5910, AB5920  AG210  AG910  BM850  BN600  JA323  JA5075  JA5076  JB792  JB894  JC882  JM350  JM356  JM483  JM5034  JM5074	 JH409  JH434  JH5014
		JB894  JB792  (x8)	JM483 (x2) (31-029717-00)	JH434	HR5052 	 NB849  48.7x63.5x8mm, FPM (50-319467-00)  NB291  82.6x98.7x12.7mm, MVQ	NA448 [2] 	 AB5900, AB5910, AB5920  AG210  AG910  BM850  BN600  JA323  JA5075  JA5076  JB792  JB894  JC882  JM350  JM356  JM483  JM5034  JM5074	 JH409  JH434  JH5014
		JC882	JM350	JH409 (31-027589-00)	HR635 	 NB775 40x52x7mm, FPM  NB849  48.7x63.5x8mm, FPM (50-319467-00)  NB848  100x120x11mm, PTFE		 AB5900, AB5910, AB5920  AG210  AG910  BM850  BN600  JA323  JA5075  JA5076  JB792  JB894  JC882  JM350  JM356  JM483  JM5034  JM5074	 JH409  JH434  JH5014
		JA5075  (31-029445-00) JA5076  (31-029446-00)	JM5034 (50-029442-00) →Ch.1A736339 JM5074 (50-029443-00) Ch.2A736339 →	JH5014 (50-029444-00)	HR5044  (24-31942-80/0)	 NA5023  50x65x8mm, FPM (50-319426-00)  LK5002  [3] 136x153x21mm, PTFE (50-319427-00)		 AB5900, AB5910, AB5920  AG210  AG910  BM850  BN600  JA323  JA5075  JA5076  JB792  JB894  JC882  JM350  JM356  JM483  JM5034  JM5074	 JH409  JH434  JH5014

LAND ROVER



KW/PS



Defender 2.5L TDI Diesel				09/90 → 12/98		13				
11 L (200Tdi)	2495	4	90.50	Direct Injection	83-79/ 113- 107	BY470 (Fibre), 1.30mm, 1 Hole (30-029688-00) BY480 (Fibre), 1.40mm, 2 Holes (30-029689-00) BY490 (Fibre), 1.50mm, 3 Holes (30-029690-00) BY500 (Fibre), 1.60mm (30-029691-00)	DV720 ▲■ (21-29688-21/0) →02/94 200Tdi DY470 ▲■ (21-29688-20/0) 03/94 → 300Tdi	EV720 (22-29688-01/0) →02/94 200Tdi EY470 [12] (22-29688-00/0) 03/94 → 300Tdi		
16 L (300Tdi)	2495	4	90.50	Direct Injection	83/113					
18 L (300Tdi)	2495	4	90.50	Direct Injection	86-83/ 117- 113					
23 L (300Tdi)	2495	4	90.50	Direct Injection						
Discovery 2.0L 16V				09/93 → 06/94		14				
20T4H (T Series)	1994	4	84.45		99/135	BS790 (Fibre)	DS792 [221] [222]	ES790		
Discovery 2.0L 16V Mk II				06/94 →		15				
20T4H (T Series)	1994	4	84.45		99/135	BS790 (Fibre) →12/95 AB5400 (MLS) (30-029270-00) 01/96 →	DS792 [221] [222] →12/95 CB5400 (21-29270-20/0) 01/96 →	ES790 →12/95 EB5400 [12] (22-29271-00/0) 01/96 →		
Discovery 2.5L Td5 Mk II Diesel				01/99 →		16				
TD5	2495	5	84.45		102/139	AB5900 (MLS), 1.20mm, 2 Holes (30-029439-00) AB5910 (MLS), 1.27mm, 1 Hole (30-029440-00) AB5920 (MLS), 1.35mm, 3 Holes (30-029441-00)	CB5900 ▲■ [238] (21-29442-20/0) →Ch.1A736339 CB5901 ▲■ [239] (21-29443-20/0) Ch.2A736340 →	EB5900 [12] (22-29444-00/0)		
Discovery 3.5L				09/89 → 06/94		17				
22 D	3531	8	88.90	V8 Injection	113/154	AB5480 (Fibre) (x2) [188] AG910 (Steel) (x8)	CG915 ■	EG914		
Discovery 3.9L V8				09/93 → 06/94		18				
Discovery 3.9L V8 Mk II				06/94 → 11/98						
35 D/36 D	3950	8	94.00	V8 Injection	134/182	AB5490 (Fibre) (x2) BR290 (Steel) (x2)	DR290 ■ (21-29715-20/0)	EG914		
Discovery 4.0L V8				11/98 →		19				
	3950	8			136/185	AY200 (Fibre) (x2) (30-029712-00)	CY200 ■ (21-29712-20/0)	EY200 (22-29712-00/0)		
Discovery 4.4L Mk II				10/04 →		20				
AJ41	4394	8	88.00		220/299	AD5610 (MLS), 2 Notches ■ (30-029255-00) 05/05 → AD5600 (MLS), 2 Notches ■ (30-029254-00) 05/05 →				

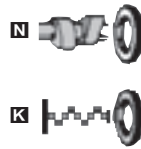
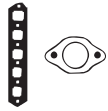

HBS224 (22-89008B)
M10x1.50x117mm (x4)
M12x1.50x100mm (x4)
M12x1.50x125mm (x10)
→02/94
200Tdi

HBS223 (22-89004B)
M10x1.50x117mm (x4)
M12x1.50x100mm (x4)
M12x1.50x140mm (x10)
03/94→
300Tdi

JC886
→02/94
200Tdi

JD471
(31-029693-00)
03/94→
300Tdi

JN872
→02/94
200Tdi

JPO20
(50-029692-00)
03/94→
300Tdi

HR801

NB775 40x52x7mm, FPM
→02/94
200Tdi

NC008 47x62x10mm, ACM
03/94→
300Tdi

NB849 48.7x63.5x8mm, FPM
(50-319467-00)
→02/94
200Tdi

NB848 100x120x11mm, PTFE
→02/94
200Tdi

NC007 [186] 56x71x9.5mm, FPM
03/94→
300Tdi

NC009 [187] 57x74x8.5mm, NBR
03/94→
300Tdi

LK5009 [3] 99x118x16.5mm, PTFE
(50-319482-00)
03/94→
300Tdi

HBS305 (22-89007B)
M11x1.50x162mm (x10)

JC950 (31-029333-00)
JC949
JC909
(31-029335-00)

LB162
(Rubber/Metal)

LB536
(Rubber)

JJ446

HR802

NB775 (x4) 40x52x7mm, FPM

NB774 35x45x7mm, FPM
(50-319419-00)

NB843 [3] 128x145x28mm, FPM
(50-319420-00)

HBS305 (22-89007B)
M11x1.50x162mm (x10)

JC950 (31-029333-00)
JC949
JC909
(31-029335-00)

LB162
(Rubber/Metal)
→12/95

LB536
(Rubber)

JM5045
(50-029331-00)
(Rubber)
01/96→

JJ446
→12/95

JH5022
(50-029271-00)
01/96→

HR802
→12/95

HR656 (x2)
(24-31939-70/0)
01/96→

NB775 (x2) 40x52x7mm, FPM
01/96→

NB774 35x45x7mm, FPM
(50-319419-00)

NB843 [3] 128x145x28mm, FPM
(50-319420-00)

JA5075 (31-029445-00)
JA5076
(31-029446-00)

JM5034
(50-029442-00)
→Ch.1A736339

JM5074
(50-029443-00)
Ch.2A736339→

JH5014
(50-029444-00)

HR5044
(24-31942-80/0)

NA5023 50x65x8mm, FPM
(50-319426-00)

LK5002 [3] 136x153x21mm, PTFE
(50-319427-00)

HBS222 (22-89003B)

JB894
JB792 (x8)

JM483 (x2)
(31-029717-00)

JH434

HR5052

NB849 48.7x63.5x8mm, FPM
(50-319467-00)

NB291 82.6x98.7x12.7mm, MVQ

JB894
JB792 (x8)

JM483 (x2)
(31-029717-00)

JH434

HR5054

NB849 48.7x63.5x8mm, FPM
(50-319467-00)

NB291 82.6x98.7x12.7mm, MVQ

JA5000
JA5001 (x4)
(31-029704-00)

JM483 (x2)
(31-029717-00)

JM5000 (x2)
(50-029714-00)
(Rubber)

JH434

HR5053

NB849 48.7x63.5x8mm, FPM
(50-319467-00)

NB291 82.6x98.7x12.7mm, MVQ

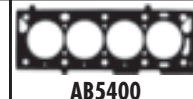

AB5400



JM483



AB5480



JM5000



AB5490

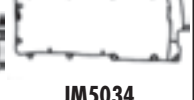

JM5034

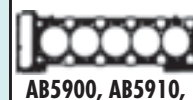

AB5900, AB5910, AB5920



JM5045



AG910



JM5074



AY200



JN872

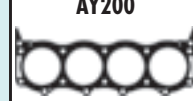

BR290



JP020

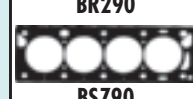

BS790



LB162



BY470, BY480, BY490, BY500



LB536



JA5000



JH434



JA5001



JH5014



JA5075



JH5022

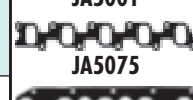

JA5076



JB792



JJ446



JB894



JC886



JC909



JC949



JC950



JD471











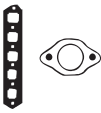

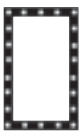

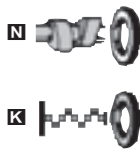





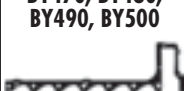













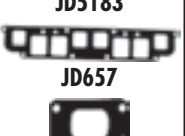

































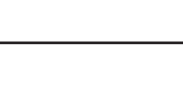













LAND ROVER

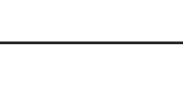

KWPS

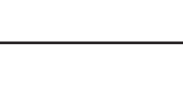

Freelander 1.8L i 16V				02/98 → 11/00		21	BW5750 (MLS) [246] (30-030305-00)		DW5757 [247] (21-30305-00/0)	ER322 (22-29294-01/0)
18K4F	1796	4	80.00		86/117		BW750 (Steel Elastomer) (30-029292-00)	DW5759 [246] [247]		
18K4F	1796	4	80.00		88/120		KM5001 [190] (40-029292-00)	DW757 (21-29292-24/0)		
								DW759 [246] [247]		
Freelander 2.0L DI Diesel				02/98 → 11/00		22	BZ440 (MLS), 1.05mm, 1 Hole (30-029569-00)		DZ440▲ (21-29569-20/0)	EZ441 [12] (22-29569-01/0)
20 T2N (L Series)	1994	4	84.45		72/98		BZ450 (MLS), 1.20mm, 2 Holes (30-029570-00)			
							BZ460 (MLS), 1.35mm, 3 Holes (30-029571-00)			
Freelander 2.0L Td4 Diesel				11/00 →		23	BZ690 (MLS), 1.45mm, 1 Hole (30-028564-00)		DZ690▲■ (21-29456-20/0)	EZ690 (22-29457-00/0)
M47D20R	1951	4	84.00		80/109		BZ700 (MLS), 1.55mm, 2 Holes (30-028565-00)			
M47D20R	1951	4	84.00		82/112		BZ710 (MLS), 1.65mm, 3 Holes (30-028566-00)			
Freelander 2.5L V6				11/00 →		24	AA5920 (MLS) (x2) (30-028596-20)		CA5920 (21-28596-20/0)	EA5920 [12] (22-28596-00/0)
25 K4F	2497	6	80.00		130/177					
Range Rover 2.4L D Diesel				04/86 → 12/90		25	BK570 (Fibre), 1.42mm, 0 Notches (x4) (30-025008-20)		DK570▲ [7] (21-25850-21/0)	GK570▲ [36] (20-25850-02/0)
11 A	2376	4			78/106		BP260 (Fibre), 1.52mm, 2 Notches (x4) (30-025013-20)			
							BK580 (Fibre), 1.62mm, 1 Notch (x4) (30-025007-20)			
Range Rover 2.5L D Diesel				04/94 → 03/02		26	BY470 (Fibre), 1.30mm, 1 Hole (30-029688-00)		DY470▲■ (21-29688-20/0)	EY470 [12] (22-29688-00/0)
17L (300Tdi)	2496	4	90.47	OHV	83/113		BY480 (Fibre), 1.40mm, 2 Holes (30-029689-00)			
19L (300Tdi)	2496	4	90.47	OHV			BY490 (Fibre), 1.50mm, 3 Holes (30-029690-00)			
20L (300Tdi)	2496	4	90.47	OHV			BY500 (Fibre), 1.60mm (30-029691-00)			
21L (300Tdi)	2496	4	90.47	OHV						
22L (300Tdi)	2496	4	90.47	OHV						
Range Rover 2.5L D Diesel				07/94 → 03/02		27	BZ110 (Fibre), 1.68mm, 2 Holes 30-027395-20		DW731▲■ 21-27179-22/0	EY280 22-27096-02/0
M51D25 (BMW)	2497	6		Indirect Injection, SOHC	100/136		BZ120 (Fibre), 1.87mm, 3 Holes 30-027396-20			
Range Rover 2.5LTDI Diesel				01/90 → 03/94		28	BY470 (Fibre), 1.30mm, 1 Hole (30-029688-00)		DV720▲■ (21-29688-21/0)	EV720 (22-29688-01/0)
11 L (200Tdi)	2496	4	90.50	Direct Injection, Turbo Intercooled			BY480 (Fibre), 1.40mm, 2 Holes (30-029689-00)			
12 L (200Tdi)	2496	4	90.50	Direct Injection, Turbo Intercooled			BY490 (Fibre), 1.50mm, 3 Holes (30-029690-00)			
14 L (200Tdi)	2496	4	90.50	Direct Injection, Turbo Intercooled			BY500 (Fibre), 1.60mm (30-029691-00)			

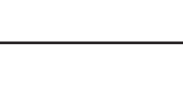
								
HBS005 Ⓢ (22-89005B) M9x1.25x412mm (x10)	JD311 ■ [192] (50-029305-00) (FPM) JC852 ■ (31-029304-00)	JN963 (31-029297-00)		HR752 ■ (24-31939-80/0)	■ NC065 ■ (x2) 30x40x7mm, FPM (50-306142-00) Black ■ NB998 ■ (x2) 30x40x7mm, FPM (50-319402-00) Brown ■ NB828 ■ 27.5x39.5x7mm, FPM (50-319399-00) ■ NB829 ■ 79.95x116x11.5mm, FPM (50-319400-00)			 AA5920  BK570, BP260, BK580  BW5750  BW750  BY470, BY480, BY490, BY500  BZ110, BZ120  BZ440, BZ450, BZ460  JA5078  JA5079  JC852  JC886  JC928  JD025  JD274  JD275  JD276  JD311  JD471
HBS282 Ⓢ (22-72002B) M11x1.50x230mm (x10)	JD657	JP097	JH5012	HR5051 ■	■ NB775 (x2) 40x52x7mm, FPM ■ NB774 ■ 35x45x7mm, FPM (50-319419-00) ■ LK5002 ■ [3] 136x153x21mm, PTFE (50-319427-00)			 JM5035  JM5076  JN581  JN872  JN955  JN963  JP020  JP067  JP097  JH5012  JH5032  JH5033  JJ536
HBS121 Ⓢ (22-11006B) M12x1.50x146.5mm (x10)	HA5006 ■ ■ (24-29152-00/0) JD5183 ■ (x2) (31-029124-00)	JM5076 (50-029456-00)	JH5032 ■ (31-029457-00) JH5033 ■ (31-029458-00)	HR5045 ■ 24-30724-07/0	■ NA5103 ■ 55x68x8mm, PTFE (50-319391-00) ■ NA5104 ■ 90x110x12mm, PTFE (50-319389-00)			 JM5076  JN581  JN872  JN955  JN963  JP020  JP067  JP097  JH5012  JH5032  JH5033  JJ536
HBS423 (22-89009B) M9x1.25x200mm (x16)	JA5079 ■ (x2) (31-029413-00) JA5078 ■ (x2) (31-029412-00)	JM5035 (x2) (31-029414-00)		HR5031 ■ (x2) (24-31939-81/0)	■ NC065 ■ (x2) 30x40x7mm, FPM (50-306142-00) Black ■ NB998 ■ (x4) 30x40x7mm, FPM (50-319402-00) Brown ■ NA5083 ■ 32.5x45x7.7mm, FPM (50-319423-00) ■ LK5000 ■ [3] 89x116x10.2mm, FPM (50-319424-00)			 JA5078  JA5079  JC852  JC886  JC928  JD025  JD274  JD275  JD276  JD311  JD471
	JC928 ■ (x4) (31-025852-10) JD025 ■ (x4) (31-025849-10) Ⓢ JF123 (31-027523-00)	JN581 (x4) JP067 (31-025850-10)						 JN581  JN872  JN955  JN963  JP020  JP067  JP097  JH5012  JH5032  JH5033  JJ536
HBS223 Ⓢ (22-89004B) M10x1.50x117mm (x4) M12x1.50x100mm (x4) M12x1.50x140mm (x10)	JD471 (31-029693-00)	JP020 (50-029692-00)		HR801 ■	■ NC008 47x62x10mm, ACM ■ NC007 ■ [186] 56x71x9.5mm, FPM ■ NC009 ■ [187] 57x74x8.5mm, NBR ■ LK5009 ■ [3] 99x118x16.5mm, PTFE (50-319482-00)			 JC928  JD025  JD274  JD275  JD276  JD311  JD471
HBS066 Ⓢ (22-11005B) M12x1.50x146.5mm (x14)	JD274 ■ (x6) 31-027183-00 JD275 ■ (x4) 31-027180-00 JD276 ■ [274] 31-027181-00	JN955 50-027179-00	JJ536 (31-027096-20)	HR280 ■ 24-30614-75/0	■ NF637 ■ 48x65x10mm, FPM (50-306222-50) ■ NB431 ■ 90x110x12mm, FPM (50-306091-50)			 JD274  JD275  JD276  JD311  JD471
HBS224 Ⓢ (22-89008B) M10x1.50x117mm (x4) M12x1.50x100mm (x4) M12x1.50x125mm (x10)	JC886	JN872		HR801 ■	■ NB775 40x52x7mm, FPM ■ NB849 ■ 48.7x63.5x8mm, FPM (50-319467-00) ■ NB848 ■ 100x120x11mm, PTFE			 JD276  JD311  JD471











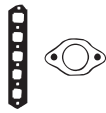

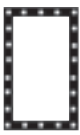



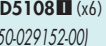
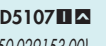
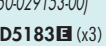
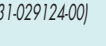
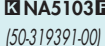
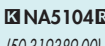

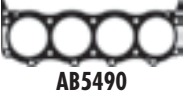

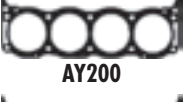







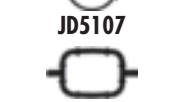



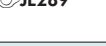
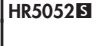
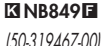
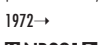





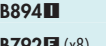
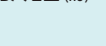
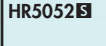
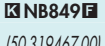
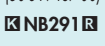
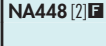



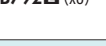
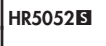
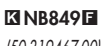
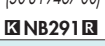

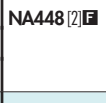
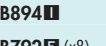
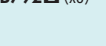
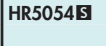
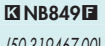
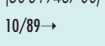



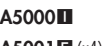
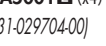
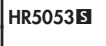
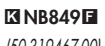
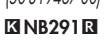



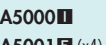
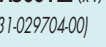
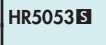
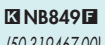
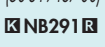

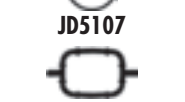
LAND ROVER

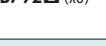

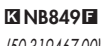
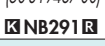
KW/PS

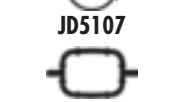

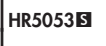
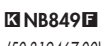
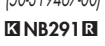
Range Rover 3.0L TD Diesel		03/02 →		29	BZ660 (MLS), 1.45mm, 1 Hole 30-028559-00 BZ670 (MLS), 1.55mm, 2 Holes 30-028560-00 BZ680 (MLS), 1.65mm, 3 Holes 30-028561-00 AB5980 (MLS), 1.80mm 30-029183-00		DZ660▲■ 21-29149-20/0	EZ660 22-29108-00/0
2926	6			130/177				
Range Rover 3.5L		07/70 →08/81		30	AB5480 (Fibre) (x2) [188] AG910 (Steel) (x2)		CG914■ →09/77 CG913■ 10/77→	EG914 1972→
389F	3532	8	88.86	97/132				
Range Rover 3.5L		01/87 →09/90		31	AB5480 (Fibre) (x2) [188] AG910 (Steel) (x2)		CG915■	EG914
Range Rover 3.5L Vogue		10/85 →09/90						
31 D	3528	8		107/146				
24 D/25 D	3528	8		120/163				
Range Rover 3.5L Vogue		08/81 →09/90		32	AB5480 (Fibre) (x2) [188] AG910 (Steel) (x2)		CG913■	EG914
11 D	3528	8		93/126				
Range Rover 3.9L		11/88 →07/94		33	AB5490 (Fibre) (x2) BR290 (Steel) (x2)		DR290■ (21-29715-20/0)	EG914 10/89→
Range Rover 3.9L Vogue SEI		11/88 →07/94						
37 D/38 D	3950	8	94.00	127/173	Direct Injection, DOHC			
35 D/36 D	3950	8	94.00	134/182	DOHC			
Range Rover 3.9L		07/94 →03/02		34	AY200 (Fibre) (x2) (30-029712-00)		CY200■ (21-29712-20/0)	EY200 (22-29712-00/0)
42 D	3947	8	V8	140/190				
Range Rover 4.0L		06/98 →03/02		35	AY200 (Fibre) (x2) (30-029712-00)		CY200■ (21-29712-20/0)	EY200 (22-29712-00/0)
44D	3950	8	94.00	136/185				
Range Rover 4.3L Vogue LSE		09/92 →07/94		36	AB5490 (Fibre) (x2) BR290 (Steel) (x2)		DR290■ (21-29715-20/0)	EG914
40 D	4275	8		149/203				
Range Rover 4.4L		05/05 →		37	AD5610 (MLS), 2 Notches ■ (30-029255-00)			
Range Rover 4.4L Sport		02/05 →						
AJ41	4394	8	88.00	220/299				
AJ41	4394	8	88.00	225/306				
Range Rover 4.6L		07/94 →03/02		38	AY200 (Fibre) (x2) (30-029712-00)		CY200■ (21-29712-20/0)	
46 D	4553	8	V8	165/224				
48D	4554	8	94.00	160/218				

								
HBS066  (22-11005B) M12x1.50x146.5mm (x14)	JD5108  (x6) (50-029152-00) JD5107   (50-029153-00) JD5183  (x3) (31-029124-00)	JM5106 50-029149-00	JH5049 (31-029108-00)	PA5016 (x24) 50-307240-70	NA5103  55x68x8mm, PTFE (50-319391-00) NA5104  90x110x12mm, PTFE (50-319389-00)			 AB5480  AB5490  AB5980  AG910  AY200  BR290  BZ660, BZ670, BZ680  JA5000  JA5001  JB792  JB894  JD5107  JD5108  JD5183
	JB894  JB792  (x8) 10/77 →  JE289	JM483 (x2) (31-029717-00)	JH434	HR5052 	NB849  48.7x63.5x8mm, FPM (50-319467-00) 1972 → NB291  82.6x98.7x12.7mm, MVQ 1972 →			 JM483  JM5000  JM5106  JH434  JH5049
HBS222  (22-89003B)	JB894  JB792  (x8)	JM483 (x2) (31-029717-00)	JH434	HR5052 	NB849  48.7x63.5x8mm, FPM (50-319467-00) NB291  82.6x98.7x12.7mm, MVQ	NA448 (2) 		 NA448 (2) 
	JB894  JB792  (x8)	JM483 (x2) (31-029717-00)	JH434	HR5052 	NB849  48.7x63.5x8mm, FPM (50-319467-00) NB291  82.6x98.7x12.7mm, MVQ	NA448 (2) 		 NA448 (2) 
	JB894  JB792  (x8)	JM483 (x2) (31-029717-00)	JH434 10/89 →	HR5054 	NB849  48.7x63.5x8mm, FPM (50-319467-00) 10/89 → NB291  82.6x98.7x12.7mm, MVQ 10/89 →			 JA5000  JA5001  JB792  JB894
	JA5000  JA5001  (x4) (31-029704-00)	JM483 (x2) (31-029717-00) JM5000 (x2) (50-029714-00) (Rubber)	JH434	HR5053 	NB849  48.7x63.5x8mm, FPM (50-319467-00) NB291  82.6x98.7x12.7mm, MVQ			 JA5001  JB792  JB894
	JA5000  JA5001  (x4) (31-029704-00)	JM483 (x2) (31-029717-00) JM5000 (x2) (50-029714-00) (Rubber)	JH434	HR5053 	NB849  48.7x63.5x8mm, FPM (50-319467-00) NB291  82.6x98.7x12.7mm, MVQ			 JB894  JD5107  JD5108
	JB894  JB792  (x8)	JM483 (x2) (31-029717-00)	JH434	HR5054 	NB849  48.7x63.5x8mm, FPM (50-319467-00) NB291  82.6x98.7x12.7mm, MVQ			 JD5107  JD5108
	JA5000  JA5001  (x4) (31-029704-00)	JM483 (x2) (31-029717-00) JM5000 (x2) (50-029714-00) (Rubber)		HR5053 	NB849  48.7x63.5x8mm, FPM (50-319467-00) NB291  82.6x98.7x12.7mm, MVQ			 JD5183



KW/PS



Model		Year Range		Cylinders		Power (KW/PS)		Engine Code	Accessories
ES 250		12/89 → 09/91		1					
		2507	6			118/160			
ES 3.0L		10/96 → 07/01		2				AG9280 (MLS)	CD9270
1MZ-FE		2995	6	87.50	Injection, DOHC, V6	135- 150/ 184- 204		AG9270 (MLS)	EG9270
ES 300		09/91 → 12/97		3				BS300 (Graphite)	DS292
3VZ-FE		2959	6	87.50	Injection, DOHC, V6	138/188		BS290 (Graphite) <i>(30-028098-00)</i>	
GS 300		03/93 → 03/05		4				AG5100 (MLS) , 0.3mm	CF5850
GS 300 T3		08/97 → 10/00							FG5100
2JZ-GE		2997	6	86.00	DOHC	156- 163/ 212- 222			
GS 400		12/97 → 11/00		5				AF5031 (MLS)	CF5030
1UZ-FE		3969	8	87.50	Injection, DOHC, V8	180- 209/ 245- 284		AF5030 (MLS)	FF5030
IS 200		04/99 →		6				AG9990 (MLS)	
IS 200 SportCross		10/02 →							
1G-FE		1988	6	75.00	Injection, DOHC	114/155			
IS 300		09/01 →		7				AG5100 (MLS) , 0.3mm	CF5850
2JZ-GE		2997	6	86.00	DOHC	156- 163/ 212- 222			FG5100
LS 400		09/97 →		8				AF5031 (MLS)	CF5030
1UZ-FE		3969	8	87.50	Injection, DOHC, V8	180- 209/ 245- 284		AF5030 (MLS)	FF5030
								→12/00	
								→12/00	
LS 400		12/89 → 08/97		9				AG7640 (Graphite)	CG7630
1UZ-FE		3969	8	87.50	Injection, DOHC, V8	180- 209/ 245- 284		AG7630 (Graphite)	FG7630
RX 3.0L 2WD		07/00 → 03/03		10				AG9280 (MLS)	CD9270
1MZ-FE		2995	6	87.50	Injection, DOHC, V6	135- 150/ 184- 204		AG9270 (MLS)	EG9270
RX 300		05/03 →		11				AG9280 (MLS)	CD9270
RX 300 V6		10/00 → 05/03						AG9270 (MLS)	EG9270
1MZ-FE		2995	6	87.50	Injection, DOHC, V6	135- 150/ 184- 204			

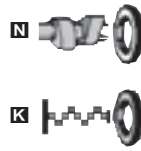
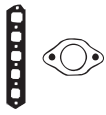



BS290

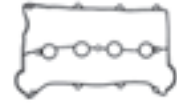

BS300



JN752

HBS394 (x16) (22-71028B)						
HBS394 (x16) (22-71028B)		JN752 (x2) (50-028055-00)		PB281 (x12)		
HBS450 (22-71026B) M11x1.25x91mm (x14)		JN831				
HBS445 (22-71025B) 01/98 →		HM5243 				
HBS450 (22-71026B) M11x1.25x91mm (x14)		JN831				
HBS445 (22-71025B) 01/98 →		HM5243 				
		HM5243 				
		HM5242   (NBR)				



CC



9



CC



9

12J	Diesel	2494	4	90.47	21
3.5V8	Petrol	3528	8	88.86	22
B Series	Petrol	1622	4	76.18	19
B Series	Petrol	1798	4	80.25	20
B Series	Diesel	1798	4	80.25	20
EN 55	Diesel	2498	4	94.00	11
EN 55	Diesel	2498	4	94.00	4
ET 70	Diesel	2496	4	94.00	12
ET 70	Diesel	2498	4	94.00	5
G16A	Petrol	1598	4	75.00	17
O Series	Petrol	1695	4	84.44	18
O Series	Petrol	1993	4	84.44	1
O Series	Petrol	1993	4	84.44	16
O Series	Petrol	1993	4	84.44	3
Prima 65	Diesel	1993	4	84.45	15
XD3	Diesel	2498	4	94.00	6
XD3	Diesel	2498	4	94.00	9
XD3P	Diesel	2498	4	94.00	6
XD3P	Diesel	2498	4	94.00	9
XD3T	Diesel	2498	4	94.00	10
XD3T	Diesel	2498	4	94.00	13
XD3T	Diesel	2498	4	94.00	5
XD3T	Diesel	2498	4	94.00	8
XD3TE	Diesel	2498	4	94.00	10
XD3TE	Diesel	2498	4	94.00	13
XD3TE	Diesel	2498	4	94.00	5
XD3TE	Diesel	2498	4	94.00	8
XUD9	Diesel	1905	4	83.00	14
XUD9	Diesel	1905	4	83.00	2
XUD9A	Diesel	1905	4	83.00	14
XUD9A	Diesel	1905	4	83.00	2
XUD9B 162	Diesel	1905	4	83.00	14
XUD9B 162	Diesel	1905	4	83.00	2

LEYLAND / LDV



KW/PS



200 2.0L L					01/89 →	1	BN670 (Fibre)		DN672	EM684
O Series	1993	4	84.44	SOHC						
200 1.9L D Diesel					01/94 →12/96	2	BX880 (Fibre), 1.36mm, 1 Notch (30-028475-00) ☞0.56 →0.67mm BX890 (Fibre), 1.40mm, 2 Notches (30-028476-00) ☞0.68 →0.71mm BX900 (Fibre), 1.44mm, 3 Notches (30-028477-00) ☞0.72 →0.75mm BX910 (Fibre), 1.48mm, 4 Notches (30-028478-00) ☞0.76 →0.79mm BX920 (Fibre), 1.52mm, 5 Notches (30-028479-00) ☞0.80 →0.83mm		DJ720▲ (21-25202-22/0)	EL890 (22-25198-01/0) GJ720▲ (20-25202-02/0)
XUD9/XUD9A/XUD9B 162	1905	4	83.00							
400 2.0L L					01/89 →	3	BN670 (Fibre)		DN672	EM684
O Series	1993	4	84.44	SOHC						
400 2.5L D Diesel					04/89 →08/93	4	BP890 (Fibre), 1.53mm, 2 Notches (30-026144-10) BP900 (Fibre), 1.63mm, 3 Notches (30-026145-10) BP910 (Fibre), 1.73mm, 4 Notches (30-026146-10)		DH890▲■	EH890 GH890▲○ (20-24586-05/0)
EN 55	2498	4	94.00		53/72					
400 2.5L TD Diesel					04/89 →08/93	5	BP890 (Fibre), 1.53mm, 2 Notches (30-026144-10)		DG052▲ (21-24586-25/0)	GM310▲
400 2.5L D Diesel					01/89 →04/96		BP900 (Fibre), 1.63mm, 3 Notches (30-026145-10) BP910 (Fibre), 1.73mm, 4 Notches (30-026146-10)			
ET 70 XD3T/XD3TE	2498 2498	4 4	94.00 94.00	Turbo	71/96					
400 2.5L D Diesel					04/89 →04/96	6	BP890 (Fibre), 1.53mm, 2 Notches (30-026144-10) BP900 (Fibre), 1.63mm, 3 Notches (30-026145-10) BP910 (Fibre), 1.73mm, 4 Notches (30-026146-10)		DH890▲■	GH890▲○ (20-24586-05/0)
XD3/XD3P	2498	4	94.00							
400 2.5L TD Diesel					11/95 →	7	BP890 (Fibre), 1.53mm, 2 Notches (30-026144-10) BP900 (Fibre), 1.63mm, 3 Notches (30-026145-10) BP910 (Fibre), 1.73mm, 4 Notches (30-026146-10)		DG052▲ (21-24586-25/0)	GM310▲
	2498	4			71/96					
400 Van Diesel					01/89 →04/96	8	BP890 (Fibre), 1.53mm, 2 Notches (30-026144-10) BP900 (Fibre), 1.63mm, 3 Notches (30-026145-10) BP910 (Fibre), 1.73mm, 4 Notches (30-026146-10)		DG052▲ (21-24586-25/0)	GM310▲
XD3T/XD3TE	2498	4	94.00	Turbo						

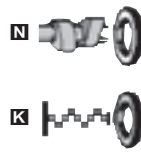
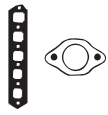

BN670



BP890, BP900,
BP910



BX880, BX890,
BX900, BX910,
BX920



JC435



JC566



JN245



JN544



HC346



JJ283



JJ315

	JC435		JJ315		NB773 46x60x7mm, FPM NB775 40x52x7mm, FPM NB774 35x45x7mm, FPM (50-319419-00) NB772 88.9x104.8x9.52mm, MVQ	
HBS084 (22-15005B) M12x1.50x123mm (x10)		JN544 (50-025202-00)	JJ283 [6] (31-025198-10) PA349 (33-102290-10) 22x16x2mm	HR569 24-30667-00/0	NF841 (x2) 35x50x8mm, FPM (50-319310-00) NA5191 42x62x7mm, PTFE (50-319500-00) NA5192 90x110x7mm, PTFE (50-319501-00)	
	JC435		JJ315		NB773 46x60x7mm, FPM NB775 40x52x7mm, FPM NB774 35x45x7mm, FPM (50-319419-00) NB772 88.9x104.8x9.52mm, MVQ	
HBS016 (22-53005B) M11x1.50x120mm (x7) M11x1.50x107.5mm (x15)	JC566 (x2)	JN245 (50-024586-00)	HC346 PA349 (33-102290-10) 22x16x2mm		NF387 42x60x10mm, NBR (50-306429-00) NF780 45x60x7mm, ACM	
HBS016 (22-53005B) M11x1.50x120mm (x7) M11x1.50x107.5mm (x15)		JN245 (50-024586-00)	HC346 PA349 (33-102290-10) 22x16x2mm	PA229 (x8) (50-324505-00) HR340	NF097 (x2) 45x62x10mm, NBR (50-306429-00) NF387 42x60x10mm, NBR (50-306429-00) NF780 45x60x7mm, ACM	
HBS016 (22-53005B) M11x1.50x120mm (x7) M11x1.50x107.5mm (x15)	JC566 (x2)	JN245 (50-024586-00)	HC346 PA349 (33-102290-10) 22x16x2mm		NF387 42x60x10mm, NBR (50-306429-00) NF780 45x60x7mm, ACM	NA195 [42]
HBS016 (22-53005B) M11x1.50x120mm (x7) M11x1.50x107.5mm (x15)		JN245 (50-024586-00)	HC346 PA349 (33-102290-10) 22x16x2mm	PA229 (x8) (50-324505-00) HR340	NF097 (x2) 45x62x10mm, NBR (50-306429-00) NF780 45x60x7mm, ACM NF387 42x60x10mm, NBR (50-306429-00)	
HBS016 (22-53005B) M11x1.50x120mm (x7) M11x1.50x107.5mm (x15)		JN245 (50-024586-00)	HC346 PA349 (33-102290-10) 22x16x2mm		NF780 45x60x7mm, ACM	NF097 (x2) [38]











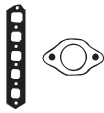

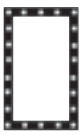























































LEYLAND / LDV



KW/PS



Convoy 2.5L D Diesel				04/96 →	9	BP890 (Fibre), 1.53mm, 2 Notches (30-026144-10) BP900 (Fibre), 1.63mm, 3 Notches (30-026145-10) BP910 (Fibre), 1.73mm, 4 Notches (30-026146-10)		DH890▲■	GH890▲○ (20-24586-05/0)
XD3/XD3P	2498	4	94.00						
Convoy 2.5L D Diesel				04/96 →	10	BP890 (Fibre), 1.53mm, 2 Notches (30-026144-10) BP900 (Fibre), 1.63mm, 3 Notches (30-026145-10) BP910 (Fibre), 1.73mm, 4 Notches (30-026146-10)		DG052▲ (21-24586-25/0)	GM310▲
XD3T/XD3TE	2498	4	94.00	Turbo					
Convoy 2.5L DI Diesel				10/98 →	11	BT800 (Fibre)		DT802 DT806[25] (21-28952-21/0)	ET800 (22-28953-00/0)
EN 55	2498	4	94.00	Injection, OHV, V4	56/76				
Convoy 2.5L TDI Diesel				10/98 →	12	BT800 (Fibre)		DT801 [24] DT805 [25] (21-28952-23/0)	ET800 [6] (22-28953-00/0)
ET 70	2496	4	94.00		74/101				
Convoy Van Diesel				04/96 →	13	BP890 (Fibre), 1.53mm, 2 Notches (30-026144-10) BP900 (Fibre), 1.63mm, 3 Notches (30-026145-10) BP910 (Fibre), 1.73mm, 4 Notches (30-026146-10)		DG052▲ (21-24586-25/0)	GM310▲
XD3T/XD3TE	2498	4	94.00	Turbo					
Pilot 1.9L D Diesel				01/96 →	14	BX880 (Fibre), 1.36mm, 1 Notch (30-028475-00) ☞0.56 →0.67mm BX890 (Fibre), 1.40mm, 2 Notches (30-028476-00) ☞0.68 →0.71mm BX900 (Fibre), 1.44mm, 3 Notches (30-028477-00) ☞0.72 →0.75mm BX910 (Fibre), 1.48mm, 4 Notches (30-028478-00) ☞0.76 →0.79mm BX920 (Fibre), 1.52mm, 5 Notches (30-028479-00) ☞0.80 →0.83mm		DJ720▲ (21-25202-22/0)	EL890 (22-25198-01/0) GJ720▲ (20-25202-02/0)
XUD9/XUD9A/XUD9B 162	1905	4	83.00						
Sherpa 100/200 Diesel				11/86 →09/94	15	BP880 (Fibre)		DP880 →09/92	EM685
Sherpa 185 Diesel									
Sherpa 200 Diesel									
Sherpa 215 Diesel									
Sherpa 220 Diesel									
Sherpa 230 Diesel									
Sherpa 240 Diesel									
Sherpa 250 Diesel									
Sherpa 255 Diesel									
Prima 65	1993	4	84.45		46/62				

						 		
HBS016  [22-53005B] M11x1.50x120mm (x7) M11x1.50x107.5mm (x15)	JC566  (x2)	JN245 (50-024586-00)	HC346  PA349 (33-102290-10) 22x16x2mm			NF387  42x60x10mm, NBR (50-306429-00) NF780  45x60x7mm, ACM	NA195 [42]	 BP880  BP890, BP900, BP910  BT800  BX880, BX890, BX900, BX910
HBS016  [22-53005B] M11x1.50x120mm (x7) M11x1.50x107.5mm (x15)		JN245 (50-024586-00)	HC346  PA349 (33-102290-10) 22x16x2mm	PA229 (x8) (50-324505-00) HR340 		NF097  (x2) 45x62x10mm, NBR NF837  NF780  45x60x7mm, ACM	NF097 (x2) [38] 	 JC566  JD064  JD065  JD066
HBS008  [22-18005B] M12x1.75x92mm (x18)	JD064  JD066  (31-029616-00)	JM5027 (31-029026-00) (Rubber/Metal) JN821 [26] (Cork)	JJ484 (50-028953-00)	HR5064  (24-31935-10/0)		NB856  47.62x66.5x11mm, PTFE (50-319371-00) NB855  67x86x9.5mm, PTFE (50-319375-00) NB854  79x99x10mm, PTFE (50-319376-00)		 JM5027  JN245  JN544  JN821
HBS008  [22-18005B] M12x1.75x92mm (x18)	JD065  (31-029617-00) JD066  (31-029616-00)	JM5027 (31-029026-00) (Rubber/Metal) JN821 [26] (Cork)	JJ484 (50-028953-00)	HR5064  (24-31935-10/0)		NB856  47.62x66.5x11mm, PTFE (50-319371-00) NB855  67x86x9.5mm, PTFE (50-319375-00) NB854  79x99x10mm, PTFE (50-319376-00)		 JM5027  JN245  JN544  JN821
HBS016  [22-53005B] M11x1.50x120mm (x7) M11x1.50x107.5mm (x15)		JN245 (50-024586-00)	HC346  PA349 (33-102290-10) 22x16x2mm			NF780  45x60x7mm, ACM	NF097 (x2) [38] 	 JN245  JN544  JN821
HBS084  [22-15005B] M12x1.50x123mm (x10)		JN544 (50-025202-00)	JJ283 [6] (31-025198-10) PA349 (33-102290-10) 22x16x2mm	HR569  24-30667-00/0		NF841 (x2) 35x50x8mm, FPM (50-319310-00) NA5191  42x62x7mm, PTFE (50-319500-00) NA5192  90x110x7mm, PTFE (50-319501-00)		 HC346  JJ283  JJ315  JJ484
			JJ315	HR625  →09/92		NB775  40x52x7mm, FPM NB773  46x60x7mm, FPM NB774  35x45x7mm, FPM (50-319419-00) NB772  88.9x104.8x9.52mm, MVQ		

LEYLAND / LDV



KW/PS



Sherpa 200/300 09/80 → 12/89 16					BD970 (Fibre) →12/86 →Eng.ch800000 BN670 (Fibre) 01/87→ Eng.CH800001→	DN672 01/87→ Eng.CH800000→	EM684 12/86→ Eng.CH800001→		
Sherpa 230 09/80 → 12/89									
Sherpa 250 09/80 → 12/89									
Sherpa 255 09/80 → 12/89									
Sherpa 280 06/82 → 12/89									
Sherpa 285 09/83 → 12/89									
Sherpa 310 09/83 → 12/89									
Sherpa 350 09/83 → 12/89									
Sherpa City 06/81 → 12/89									
O Series	1993	4	84.44	SOHC					
Sherpa 1.6L 01/83 → 09/88 17					EG5260				
G16A	1598	4	75.00	48/65					
Sherpa 100/200 09/78 → 12/88 18					BD970 (Fibre) →12/86 →Eng.ch800000 BN670 (Fibre) 01/87→ Eng.CH800001→	DN672 01/87→ Eng.CH800000→	EM684 12/86→ Eng.CH800001→		
Sherpa 230 09/78 → 12/88									
Sherpa 250 09/78 → 12/87									
Sherpa 255 09/78 → 12/87									
Sherpa City 06/81 → 12/89									
O Series	1695	4	84.44						
Sherpa 185 09/74 → 09/78 19								AK660 (Fibre) (30-027581-00)	
Sherpa 215 09/74 → 09/78									
Sherpa 220 01/75 → 09/78									
B Series	1622	4	76.18	Vertical Engine					
Sherpa 100/200 09/74 → 09/78 20					AK660 (Fibre) (30-027581-00)	CK663	EG411		
Sherpa 100/200 Diesel 09/74 → 03/88									
Sherpa 215 09/74 → 09/78									
Sherpa 215 Diesel 09/74 → 03/88									
Sherpa 220 09/74 → 09/78									
Sherpa 220 Diesel 09/74 → 03/88									
Sherpa 230 Diesel 09/78 → 03/88									
Sherpa 240 09/74 → 09/78									
Sherpa 240 Diesel 09/74 → 03/88									
Sherpa 250 02/75 → 09/78									
Sherpa 250 Diesel 09/74 → 03/88									
Sherpa 255 Diesel 09/78 → 03/88									
Sherpa 280 Diesel 09/78 → 03/88									
Sherpa City Diesel 06/82 → 03/88									
B Series	1798	4	80.25						
B Series	1798	4	80.25	OHV, Horizontal					

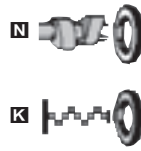
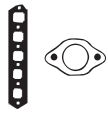

AK660



BD970



BN670



JA282



JC435



JE241



JM315



KT005



JH396



JJ315

LEYLAND / LDV



KW/PS



Sherpa 200/300 Diesel				01/84 → 12/89	21	BM850 (Fibre) (30-027588-00)	DM850 ■ (21-27588-20/0)	EM850 (22-27589-00/0)
Sherpa 310 Diesel				01/84 → 12/89				
Sherpa 3500EA Diesel				01/84 → 12/89				
Sherpa City Diesel				01/85 → 12/89				
12J	2494	4	90.47	Indirect Injection				
Sherpa 3.5L L				01/72 → 08/90	22	AB5480 (Fibre) (x2) [188]	CG914 ■	EG914
3.5V8	3528	8	88.86	Carburettor, V8				

	JC882	JM315	JH409 <i>(31-027589-00)</i>	HR635 (x2)	NB775 40x52x7mm, FPM NB849 48.7x63.5x8mm, FPM <i>(50-319467-00)</i> NB848 100x120x11mm, PTFE	
	JB894 JE289	JM483 (x2) <i>(31-029717-00)</i>	JH434	HR5052	NB849 48.7x63.5x8mm, FPM <i>(50-319467-00)</i> NB291 82.6x98.7x12.7mm, MVQ	

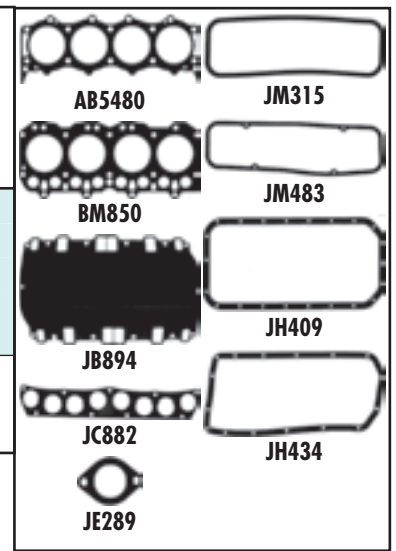



KW/PS



Cortina 1.6L					01/63 → 12/69	1	AF880 (Fibre)	CF880 ■ ○	EH761
Twin Cam	1558	4	82.55	DOHC					
Elan 1.6L					01/68 → 12/71	2	AF880 (Fibre)	CF880 ■ ○	EH761
Elan 1.6L 130									
Elan 1.6L 54									
Elan 1.6L Series I									
Elan 1.6L Series II									
Twin Cam	1558	4	82.55	DOHC					
Elan 1.6L 130/5					01/73 → 12/74	3	AF880 (Fibre)	CF880 ■ ○	EH761
Elan 1.6L Sprint									
Elan 1.6L Sprint 5									
Twin Cam	1558	4	82.55	DOHC					
Elise Convertible 1.8L 111 S					03/99 → 11/00	4	BW5750 (MLS) [246] (30-030305-00) BW750 (Steel Elastomer) (30-029292-00) KM5001 [190] (40-029292-00)	DW754 (21-29292-21/0)	ER322 (22-29294-01/0)
18 K4K (VVC)	1796	4	80.00	Injection, DOHC	107- 110/ 146- 150				
Elise Convertible 1.8L 16V					08/95 → 11/00	5	BW5750 (MLS) [246] (30-030305-00) BW750 (Steel Elastomer) (30-029292-00) KM5001 [190] (40-029292-00)	DW5757 [247] (21-30305-00/0) DW757 (21-29292-24/0)	ER322 (22-29294-01/0)
18 K4F	1796	4	80.00	MPi, DOHC	85-88/ 116- 120 90/122				
18 K4F	1796	4	80.00						
Europa Coupe 1.6L					05/70 → 04/76	6	AF880 (Fibre)	CF880 ■ ○	EH761
Twin Cam	1558	4	82.55		78/106				

						 AF880	
	JA475 (x4)	JM460	HC060		NA576 36.5x52.3x8mm, MVQ (50-306573-00) NA793 79x95.3x11.1mm, MVQ	NA580 (2) NA583 (2)	 BW750
	JA475 (x4)	JM460	HC060		NA576 36.5x52.3x8mm, MVQ (50-306573-00) NA793 79x95.3x11.1mm, MVQ	NA580 (2) NA583 (2)	 BW750 JA475 JC852
	JA475 (x4)	JM460	HC060		NA576 36.5x52.3x8mm, MVQ (50-306573-00) NA793 79x95.3x11.1mm, MVQ		 JD311 JD563
HBS005 (22-89005B) M9x1.25x412mm (x10)	JD564 (31-029307-00) JD563 (31-029306-00) JC852 (31-029304-00)	JN963 (31-029297-00)		HR752 (24-31939-80/0)	NC065 (x2) 30x40x7mm, FPM (50-306142-00) Black NB998 (x2) 30x40x7mm, FPM (50-319402-00) Brown NB828 27.5x39.5x7mm, FPM (50-319399-00) NB829 79.95x116x11.5mm, FPM (50-319400-00)		 JD564 JM460
HBS005 (22-89005B) M9x1.25x412mm (x10)	JD311 [192] (50-029305-00) (FPM) JC852 (31-029304-00)	JN963 (31-029297-00)		HR752 (24-31939-80/0)	NC065 (x2) 30x40x7mm, FPM (50-306142-00) Black NB998 (x2) 30x40x7mm, FPM (50-319402-00) Brown NB828 27.5x39.5x7mm, FPM (50-319399-00) NB829 79.95x116x11.5mm, FPM (50-319400-00)		 JN963
	JA475 (x4)	JM460	HC060		NA576 36.5x52.3x8mm, MVQ (50-306573-00) NA793 79x95.3x11.1mm, MVQ		



CC



9



CC



9

M	Petrol	1970	4	80.00	91
MA	Petrol	1970	4	80.00	91
MA (California)	Petrol	1970	4	80.00	100
MD25NA	Diesel	2500	4	94.00	105
MD25TI	Diesel	2500	4	94.00	105
PN	Diesel	1720	4	78.00	124
PN	Diesel	1720	4	78.00	55
PN26	Diesel	1720	4	78.00	55
PN27	Diesel	1720	4	78.00	55
PN46	Diesel	1720	4	78.00	55
PN54	Diesel	1720	4	78.00	55
PN62	Diesel	1720	4	78.00	55
R2	Diesel	2184	4	86.00	119
R2	Diesel	2184	4	86.00	120
R203	Diesel	2169	4	86.00	117
R207	Diesel	2169	4	86.00	117
R290	Diesel	2184	4	86.00	102
R5A2	Petrol	2184	4	86.00	101
RF OHC	Diesel	1998	4	86.00	107
RF OHC	Diesel	1998	4	86.00	108
RF OHC	Diesel	1998	4	86.00	115
RF OHC	Diesel	1998	4	86.00	150
RF OHC	Diesel	1998	4	86.00	76
RF OHC	Diesel	1998	4	86.00	82
RF1G	Diesel	1998	4	86.00	64
RF3F	Diesel	1998	4	86.00	149
RF3F	Diesel	1998	4	86.00	84
RF4F	Diesel	1998	4	86.00	149
RF4F	Diesel	1998	4	86.00	65
RF4F	Diesel	1998	4	86.00	66
RF4F	Diesel	1998	4	86.00	84
RF5C	Diesel	1998	4	86.00	127
RF5C	Diesel	1998	4	86.00	13
RF-CX	Diesel	1998	4	86.00	83
RF65	Diesel	1998	4	86.00	82
RF-N	Diesel	1998	4	86.00	81
RTJ	Diesel	1753	4	82.50	22
RTK	Diesel	1753	4	82.50	22
S2	Diesel	2209	4	88.90	104
S2	Diesel	2209	4	88.90	118
S2	Diesel	2209	4	88.90	145
S2	Diesel	2209	4	88.90	23
S2	Diesel	2209	4	88.90	99
SL	Diesel	3455	4	100.00	151
T	Petrol	1272	4	73.00	25
TC	Petrol	1272	4	73.00	25
VB	Petrol	1796	4	78.00	125
WLE7	Diesel	2500	4	93.00	105
WL-T	Diesel	2499	4	93.00	130
Y601	Diesel	1560	4	75.00	8
Z5-DE	Petrol	1489	4	75.30	41
Z6	Petrol	1598	4	78.00	7
ZM	Petrol	1598	4	78.00	45
ZM	Petrol	1598	4	78.00	47

MAZDA



KW/PS

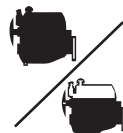

2 1.25						04/03 →	1	AG8310 (Steel) (30-030170-00)	CB5120 (21-29248-00/0)	EB5120
FUJA	1242	4	71.90	DOHC	55/75					
2 1.4L						04/03 →	2	AB5130 (MLS) (30-029249-00)	CB5132 (21-29249-10/0)	EB5120
FXJA	1388	4	76.00	DOHC	59/80					
2 1.4L CD Diesel						04/03 →	3	AD5130 (MLS), 1.25mm, 2 Notches, +3 Notches (30-029277-00) AD5140 (MLS), 1.30mm, 3 Notches, +3 Notches (30-029278-00) AD5150 (MLS), 1.35mm, 1 Notch, +3 Notches (30-029279-00) AD5160 (MLS), 1.40mm, +3 Notches, 4 Notches (30-029280-00) AD5170 (MLS), 1.45mm, +3 Notches, 5 Notches (30-029281-00)	CD5130▲ (21-29277-00/0)	
F6JA/F6JB	1399	4	73.70	Direct Injection, SOHC	50/68					
2 1.6L						04/03 →	4	AC5860 (MLS), 1.25mm (30-029526-00) →09/02 AG9560 (MLS) (30-030341-00) 10/03 →	CC5860 (21-29526-20/0) →09/02	EB5120 EY650 (22-28750-00/0)
FYJA	1596	4	79.00	DOHC	74/100					
3 1.4L						02/04 →	5	AB5130 (MLS) (30-029249-00)		EB5120
	1388	4			59/80					
3 1.6L						10/03 →	6	AG8170 (MLS) LF	CG8170	FG8170
B6ZE	1598	4	78.00		87/118					
3 1.6L						02/04 →	7	AG8170 (MLS) LF	CG8170	
Z6	1598	4	78.00		77/105					
3 1.6L DI Turbo Diesel						06/04 →	8	AD5130 (MLS), 1.25mm, 2 Notches, +3 Notches (30-029277-00) AD5140 (MLS), 1.30mm, 3 Notches, +3 Notches (30-029278-00) AD5150 (MLS), 1.35mm, 1 Notch, +3 Notches (30-029279-00) AD5160 (MLS), 1.40mm, +3 Notches, 4 Notches (30-029280-00) AD5170 (MLS), 1.45mm, +3 Notches, 5 Notches (30-029281-00)	CD5140▲ (21-29278-00/0)	
Y601	1560	4	75.00	Direct Injection, DOHC	80-81/ 109- 110					
3 2.0L						10/03 →	9	AG8170 (MLS)		
LF17	1999	4	87.50		104/141					
5 1.8L						03/05 →	10	AC5940 (MLS) (30-029554-00)		
L823	1798	4	83.00	Injection, DOHC	85/116					
5 2.0L						03/05 →	11	AG8170 (MLS)		
LFF7	1999	4	87.50	Injection, DOHC	107/146					

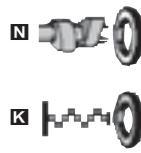
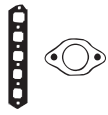

AB5130



AC5860



AC5940



AD5130, AD5140,
AD5150, AD5160,
AD5170



JD5164

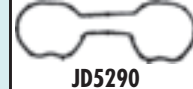























JD5290



JM5155



JE5025

HBS078  (22-18086B) M10x1.50x143mm (x10)	JD5866  (50-030340-00)					
HBS078  (22-18086B) M10x1.50x143mm (x10)	JD5866  (50-030340-00)	JM5155 [17] (50-029587-00)		HR809  (50-319363-00) HR808  (50-319362-00)	NC048 (x2) 37.2x52.35x6mm, FPM (50-319368-00) NA5137  32.9x47.4x5mm, FPM (50-319367-00) LK5004  [3] 80x182x19.4mm, PTFE (50-307318-70)	
HBS359  (22-15018B) M11x1.50x150mm (x10)	HA5029  (24-35042-80/0) JD5829  (31-030265-00)	JM5299 12/01 → F6JA/F6JB			NA5258 27x47x7mm NA5259  40x55x6.4mm	HL5033 [245] 
HBS078  (22-18086B) M10x1.50x143mm (x10)	JD5290  (50-029499-00) JD5866  (50-030340-00) JD5164  (31-029032-00) JD5865  (31-030338-00)	JM5155 [17] (50-029587-00)	JE5025 (31-028750-00)	HR809  (50-319363-00) HR808  (50-319362-00)	NC048 (x2) 37.2x52.35x6mm, FPM (50-319368-00) NA5137  32.9x47.4x5mm, FPM (50-319367-00) LK5004  [3] 80x182x19.4mm, PTFE (50-307318-70)	
HBS078  (22-18086B) M10x1.50x143mm (x10)		JM5155 [17] (50-029587-00)		HR809  (50-319363-00) HR808  (50-319362-00)	NC048 (x2) 37.2x52.35x6mm, FPM (50-319368-00) NA5137  32.9x47.4x5mm, FPM (50-319367-00) LK5004  [3] 80x182x19.4mm, PTFE (50-307318-70)	
HBS369  (22-18095B) M10x1.50x145.5mm (x10)		JM5311				
HBS369  (22-18095B) M10x1.50x145.5mm (x10)		JM5311				
HBS359  (22-15018B) M11x1.50x150mm (x10)	JD5830  (50-030266-00) HA5031   (24-35043-00/0) HA5030   (24-35042-90/0) JD5829  (31-030265-00)	JM7034 (50-030264-00)			NA5258 27x47x7mm NA5259  40x55x6.4mm	
HBS369  (22-18095B) M10x1.50x145.5mm (x10)						
HBS369  (22-18095B) M10x1.50x145.5mm (x10)						
HBS369  (22-18095B) M10x1.50x145.5mm (x10)						

MAZDA



KW/PS



6 1.8L		08/02 →		12		AC5940 (MLS)			
L813	1798	4	83.00		88/120		(30-029554-00)		
6 2.0L CITD 4x4 Station Wagon Diesel		10/02 → 02/05		13		AG8190 (MLS)		CG8190	FG8190
6 2.0L DI Diesel		06/02 →							
RF5C	1998	4	86.00	Direct Injection	89/121				
6 2.0L		06/02 →		14		AD5220 (MLS)			
LF17/LF18	1999	4	87.50		104/141		(30-029824-00)		
LFF7	1999	4	87.50	Injection, DOHC	107/146				
6 2.3L		06/02 →		15		AD5220 (MLS)		CD5220	
6 2.3L AWD		11/02 →						(21-29824-20/0)	
L3C1	2261	4			119/162				
L3C1	2261	4	87.50		122/166				
121 1.1L		10/87 → 10/90		16		BR960 (Graphite)			
B1	1138	4	68.00	SOHC	38-42/ 52-57		(30-028001-00)		
B116	1139	4	68.00	SOHC	38-42/ 52-57				
121 1.25		03/96 →		17		BY650 (MLS)		DY650	EY650
DHF/DHG	1242	4	72.00	Injection	55/75		(30-028754-00) →05/98	(21-28754-20/0) →05/98	(22-28750-00/0)
							AB5120 (MLS) (30-029248-00) 05/98 →	DY651 (21-28754-21/0) 05/98 →	
121 1.3L		10/87 → 10/90		18		BR960 (Graphite)		DR961	GR961
B3	1324	4	71.00	DOHC	40/54		(30-028001-00)		
121 1.3L		03/96 →		19		BT140 (Fibre)		DY671	EY671
	1299	4			37/50		(30-026496-00)	(21-26496-21/0)	(22-29632-00/0)
121 1.3L		03/96 →		20		BT140 (Fibre)		DY671	EY671
	1299	4			44/60		(30-026496-00)	(21-26496-21/0)	(22-29632-00/0)
121 1.3L 16V		11/90 → 03/96		21		BV430 (Graphite)		DV431	GV431
B3 (16V)	1324	4	71.00	Injection	39-40/ 53-54		AG9080 (MLS), 1.20mm		
B3 (16V)	1324	4	71.00	Injection	53-54/ 72-73				

HBS369 (22-18095B) M10x1.50x145.5mm (x10)				HR5063 (24-31945-10/0)	NA5157 37x50x8mm, PTFE (50-319442-00) LK5005 [3] 88x188x15mm, PTFE (50-319441-00)		
		JM5314					
HBS369 (22-18095B) M10x1.50x145.5mm (x10)							
HBS369 (22-18095B) M10x1.50x145.5mm (x10)							
HBS406 (22-75007B)							
HBS078 (22-18086B) M10x1.50x143mm (x10)	JD5230 (x2) (50-028751-00) JD5164 (31-029032-00)	JM5155 [17] (50-029587-00)	JE5025 (31-028750-00)	HR809 (50-319363-00) HR808 (50-319362-00)	NA5137 32.9x47.4x5mm, FPM (50-319367-00) LK5004 [3] 80x182x19.4mm, PTFE (50-307318-70)		
HBS406 (22-75007B)	JD109	JN628 (50-028048-00)	JJ354	PA883 (x8)	NJ448 30x44x7mm, NBR NJ650 83x100x9mm, ACM		
HBS050 (22-18001B) M11x1.50x120mm (x10)	JD5151 (31-029227-00) JD545 (x4) (31-029228-00) HA497	JN105 (31-027902-00)	JH5015 (50-029632-00)	HR655 24-30691-15/0	NA576 36.5x52.3x8mm, MVQ (50-306573-00) NB788 79.4x95.3x11.1mm, PTFE (50-306413-50)		
HBS050 (22-18001B) M11x1.50x120mm (x10) HBS078 (22-18086B) M10x1.50x143mm (x10)	JD5151 (31-029227-00) JD545 (x4) (31-029228-00) HA497	JN105 (31-027902-00)	JH5015 (50-029632-00)	HR655 24-30691-15/0	NA576 36.5x52.3x8mm, MVQ (50-306573-00) NB788 79.4x95.3x11.1mm, PTFE (50-306413-50)		
HBS406 (22-75007B)	JD5753 JE101	JN774		PA956 (x16)	NJ448 30x44x7mm, NBR NK157 84x100x10mm, FPM		

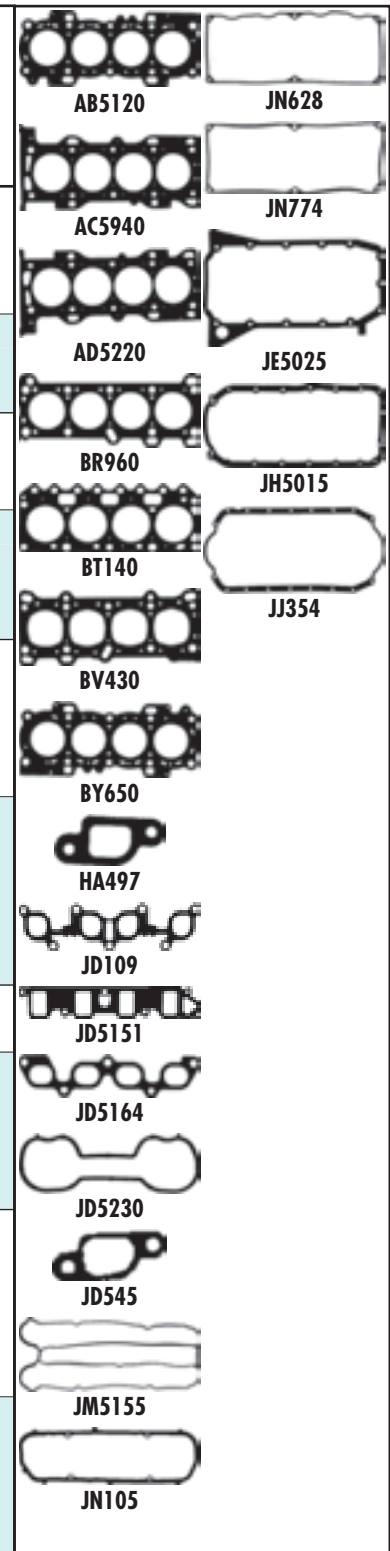





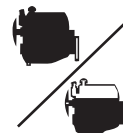



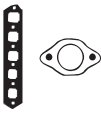

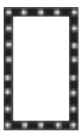

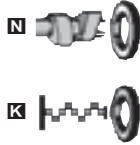

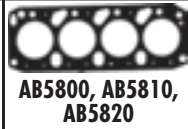











































KW/PS



121 1.8L D Diesel				03/96 →		22	BW010 (Fibre), 1.36mm, 2 Notches (30-027536-00) 0.43 → 0.68mm AB5800 (Fibre), 1.36mm, 2 Teeth [4] (30-027530-00) 0.43 → 0.68mm BW020 (Fibre), 1.42mm, 3 Notches (30-027537-00) 0.681 → 0.74mm AB5810 (Fibre), 1.42mm, 3 Teeth [4] (30-027531-00) 0.681 → 0.74mm BW030 (Fibre), 1.52mm, 4 Notches (30-027538-00) 0.741 → 0.86mm AB5820 (Fibre), 1.52mm, 4 Teeth [4] (30-027532-00) 0.741 → 0.86mm	DT193▲ (21-26448-21/0)	ET192
RTJ/RTK	1753	4	82.50	Indirect Injection	44/60				
220 2.2L D Diesel				09/79 → 12/90		23	AJ630 (Graphite)	CJ631 ◻ ○ (21-27991-20/0) → 07/82 CJ633 08/82 →	FJ631 → 07/82 FJ632 08/82 →
S2	2209	4	88.90	Indirect Injection	51-52/ 70-71				
323 1.1L				11/80 → 04/90		24	BJ420 (Fibre)	DJ420	
E1	1071	4	70.00	SOHC	40/54				
323 1.3L				01/77 → 05/86		25	AJ650 (Graphite)	CJ652 ◻ → 02/78	FJ651 FJ652 → 02/78 FJ653 03/78 →
T	1272	4	73.00	SOHC	44/60				
TC	1272	4	73.00			44-49/ 60-67			
323 1.3L				11/80 → 04/90		26	BJ430 (Graphite) (30-026179-10)	DJ430 → 11/82 DJ431 ◻ 12/82 → 12/84 DJ432 ◻ 01/85 →	GJ430 → 11/82 GJ431 12/82 → 12/84 GJ432 01/85 →
E3	1296	4	77.00	SOHC	44-55/ 60-75				
323 1.3L				11/80 → 10/85		27	BJ430 (Graphite) (30-026179-10)	DJ430 → 11/82 DJ431 ◻ 12/82 → 12/84 DJ432 ◻ 01/85 →	GJ430 → 11/82 GJ431 12/82 → GJ432 01/85 →
E3	1296	4	77.00	SOHC	44-55/ 60-75				
323 1.3L				09/89 → 06/91		28	BR960 (Graphite) (30-028001-00)	DR961	
B383/B3E	1324	4	71.00		49/67				
323 1.3L				09/89 → 07/94		29	BR960 (Graphite) (30-028001-00)	DR961	
B3E	1324	4	71.00		49/67				
323 1.3L 16V				09/89 → 07/94		30	BV430 (Graphite)	DV431	GV431
B3 (16V)	1324	4	71.00	Injection	39-40/ 53-54				
B3 (16V)	1324	4	71.00	Injection	53-54/ 72-73				

								 AB5800, AB5810, AB5820	 JN816
HBS033  (22-18007B) M12x1.75x136mm (x10)	JD240  (31-026450-00) JD310  (31-026847-00)	JN816 (50-026448-10)	JJ463 (50-028438-00)	HR801 	NB785 28x38x7mm, FPM (50-305940-50) NB984 66.67x89.3x10mm, FPM (50-306841-50) NA793 79x95.3x11.1mm, MVQ NC086 [3] 79.8x184x18.8mm, PTFE (50-319517-00)	HL5018 [245]  NC044 [15]	 AJ630	 JH040	
	JC775  (x4) →07/82 JA052  (x4)	JN595		PA426 (x8)	NJ367 51x70x11mm, NBR NJ330 101.6x125x13mm, MVQ		 AJ650	 JJ149	
	JC183  JC163  (x2)  JE102 (x2)	JN396 (50-026180-00) HL508 	JJ149	KJ710 (x8)	NB384 40x55x8mm, NBR NJ099 70x88x12mm, MVQ		 BJ420, BJ430	 JJ463	
	JA086 	JM053	JH040	KJ710 (x8)	NJ384 NB384 40x55x8mm, NBR NJ099 70x88x12mm, MVQ		 BR960		
	JC183  →11/82 JC551  12/82→12/84 JC642  01/85→ JC163  (x2) →11/82 JC250  12/82→	JN396 (50-026180-00) HL508 	JJ149		NB384 40x55x8mm, NBR NJ099 70x88x12mm, MVQ		 BV430		
	JC183  →11/82 JC551  12/82→ JC163  (x2) →11/82 JC250  12/82→	JN396 (50-026180-00) HL508 	JJ149		NB384 40x55x8mm, NBR NJ099 70x88x12mm, MVQ		 BW010, BW020, BW030		
HBS406 (22-75007B)		JN628 (50-028048-00)					 JA086		
HBS406 (22-75007B)		JN628 (50-028048-00)	HC5009 				 JC163		
HBS406 (22-75007B)	JD5753   JE101	JN774		PA956 (x16)	NJ448 30x44x7mm, NBR NK157 84x100x10mm, FPM		 JC183		
							 JC250		
							 JC551		
							 JC642		
							 JC775		
							 JD240		
							 JD310		
							 JN396		
							 JN595		
							 JN628		
							 JN774		

MAZDA



KW/PS



323 1.3L 16V					08/94 → 09/98	31	BV430 (Graphite) AG9080 (MLS), 1.20mm	DV431	GV431
B3 (16V)	1324	4	71.00	Injection		53-54/ 72-73			
323 1.3L 16V					08/94 → 09/98	32	BV430 (Graphite) AG9080 (MLS), 1.20mm	DV431	GV431
B3 (16V)	1324	4	71.00	Injection		53-54/ 72-73			
323 1.3L i					09/85 → 08/89	33	BR960 (Graphite) (30-028001-00)	DR961	
B383/B3E	1324	4	71.00			49/67			
323 1.4L					09/87 → 10/89	34	BR960 (Graphite) (30-028001-00)	DR961	
B3	1324	4	71.00	DOHC		40/54			
323 1.4L					01/01 → 05/04	35	AG9080 (MLS), 1.20mm		
323 1.4L 16V					09/98 → 01/01				
B3 (16V)	1324	4	71.00	Injection		53-54/ 72-73			
B3 ME	1324	4	71.00	Injection, SOHC		54/73			
323 1.4L					04/87 → 07/89	36	BR960 (Graphite) (30-028001-00)	DR960 DR961	
B3	1324	4	71.00	DOHC		40/54			
323 1.5L					05/81 → 12/85	37	BJ430 (Graphite) (30-026179-10) 06/80 → 12/84 BP540 (Graphite) 01/85 →	DJ430 → 11/82 DJ431 ■ 12/82 → 12/84 DP540 01/85 →	GJ430 → 11/82 GJ431 12/82 → 12/84 GP540 01/85 →
E5	1490	4	77.00	SOHC		54-65/ 73-88			
323 1.5L					03/82 → 09/86	38	BJ430 (Graphite) (30-026179-10) → 12/84 BP540 (Graphite) 01/85 →	DJ431 ■ 12/82 → 12/84 DP540 01/85 →	GJ431 12/82 → 12/84 GP540 01/85 →
E5	1490	4	77.00	SOHC		54-65/ 73-88			
323 1.5L					08/85 → 05/89	39	BJ430 (Graphite) (30-026179-10) BP540 (Graphite) BP600 (Graphite) (30-027997-00)	DP602 (21-27997-22/0)	FG7850 GP602 (20-27997-02/0)
E5	1490	4	77.00	SOHC		54-65/ 73-88			
B50/B53	1490	4	78.00			54-55/ 73-75			
323 1.5L					01/87 → 10/89	40	BP600 (Graphite) (30-027997-00)	DP602 (21-27997-22/0)	GP602 (20-27997-02/0)
B50/B53	1490	4	78.00			54-55/ 73-75			
B5	1498	4	78.00	SOHC		54-55/ 73-75			
323 1.5L 16V					07/94 → 09/98	41	AG5120 (MLS), 0.45mm	CG5380	
Z5-DE	1489	4	75.30	Injection, DOHC		65/88			
323 1.5L 16V					09/98 → 01/01	42	AA5030 (MLS) → 09/00	CA5030 → 09/00	
ZL	1498	4				65/88			
323 1.5L 16V					09/98 → 01/01	43	AA5030 (MLS) → 09/00	CA5030 → 09/00	
	1498	4				65/88			
323 1.5L i					08/85 → 05/89	44	BP540 (Graphite)	DP540	
323 1.5L i Turbo					08/85 → 05/89				
E5E3	1490	4	77.00			70/95			
E5E2	1490	4	77.00			85/115			
323 1.6L Mk VI					01/01 → 05/04	45			
ZM	1598	4	78.00			70-72/ 95-98			

							 BJ430 BP540 BP600 BR960 BV430 JC163 JC183 JC250 JC551 JC630 JC974 JN396 JN628 JN774 JJ149 JJ354
HBS406 (22-75007B)	JD5753 JE101	JN774		PA956 (x16)	NJ448 30x44x7mm, NBR NK157 84x100x10mm, FPM		
HBS406 (22-75007B)	JD5753 JE101	JN774		PA956 (x16)	NJ448 30x44x7mm, NBR NK158 37x50.5x7mm, ACM NK157 84x100x10mm, FPM		
		JN628 (50-028048-00)					
HBS406 (22-75007B)		JN628 (50-028048-00)					
HBS406 (22-75007B)							
		JN628 (50-028048-00)					
	JC183 →11/82 JC551 12/82→ JC163 (x2) 06/80→11/82 JC250 12/82→12/84 JC630 01/85→	JN396 (50-026180-00) HL508	JJ149	KJ710 (x8)	NB384 40x55x8mm, NBR NJ099 70x88x12mm, MVQ		
	JC551 JC250 12/82→12/84 JC630 01/85→	JN396 (50-026180-00) HL508	JJ149	KJ710 (x8)	NB384 40x55x8mm, NBR NJ099 70x88x12mm, MVQ		
HBS406 (22-75007B)	JC974	JN628 (50-028048-00)	JJ354	PA883 (x8)	NJ448 30x44x7mm, NBR NJ448 30x44x7mm, NBR NJ650 83x100x9mm, ACM		
HBS406 (22-75007B)	JC974	JN628 (50-028048-00)	JJ354	PA883 (x8)	NJ448 30x44x7mm, NBR NJ448 30x44x7mm, NBR NJ650 83x100x9mm, ACM		
HBS420 (22-75008B) M11x1.50x100mm (x10)		JM5287	HC5009	PB354 (x8) PB353 (x8)	NK158 37x50.5x7mm, ACM		
HBS420 (22-75008B) M11x1.50x100mm (x10)		JM5319 →09/00 ZL			NK158 37x50.5x7mm, ACM		
HBS420 (22-75008B) M11x1.50x100mm (x10)		JM5319 →09/00			NK158 37x50.5x7mm, ACM		
HBS420 (22-75008B) M11x1.50x100mm (x10)							







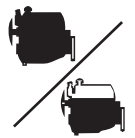



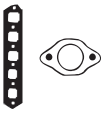

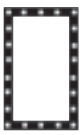

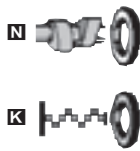













































































MAZDA



KW/PS



323 1.6L						09/87 → 10/89	46	BP600 (Graphite) (30-027997-00)	DP601	GP601 (20-27997-01/0)
323 1.6L GT Turbo 4WD						08/87 → 10/89				
B68	1597	4			110/150					
	1597	4	78.00		54/73					
323 1.6L						01/01 → 05/04	47	BV380 (MLS) (30-028871-00)	DV380	
ZM	1598	4	78.00		70-72/ 95-98					
323 1.6L						09/86 → 10/95	48	BV110 (Fibre)	DV110 (21-28009-20/0)	
B6E	1598	4	78.00	Carburettor, SOHC	62-63/ 84-86					
B65M	1598	4	78.00	SOHC	63-66/ 86-90					
323 1.6L 16V						08/89 → 10/94	49	BP570 (Graphite) (30-027996-00)	DP571 (21-27996-21/0)	GP571 (20-27996-01/0)
B6	1598	4	78.00	Injection, DOHC	64-65/ 87-88					
323 1.6L 16V						03/91 → 10/94	50	BV110 (Fibre)	DV110 (21-28009-20/0)	GV110
B6	1598	4	78.00	Injection, DOHC	64-65/ 87-88					
323 1.6L GT						11/86 → 10/89	51	BP600 (Graphite) (30-027997-00)	DP601	GP601 (20-27997-01/0)
B6	1597	4	78.00	SOHC	63/86					
323 1.6L GT						08/85 → 12/88	52	BP600 (Graphite) (30-027997-00)	DP600	GP600
B6	1598	4	78.00	Injection, SOHC	77/105					
323 1.6L GT Turbo						10/85 → 11/91	53	BP570 (Graphite) (30-027996-00)	DP570 (21-27996-20/0) → 12/87 DP571 (21-27996-21/0) 01/88 →	GP570 → 12/87 GP571 (20-27996-01/0) 01/88 →
B6	1598	4	78.00	DOHC	103/140					
323 1.6L TD Diesel						02/95 → 09/98	54	AB5010 (MLS), 1.40mm (30-029163-00) AB5020 (MLS), 1.45mm, 1 Hole (30-029164-00) AB5030 (MLS), 1.50mm, 2 Holes (30-029165-00)	CY811▲■ (21-27776-22/0)	FY811▲ (20-27776-02/0) GS435
4EE1-T	1686	4	79.00	SOHC	60-65/ 82-88					
323 1.7L D Diesel						04/86 → 07/94	55	BS070 (Graphite) (30-028004-00)	DS070	GS070
PN26/PN27	1720	4	78.00	Indirect Injection, SOHC	40-44/ 54-60					
PN54	1720	4	78.00	SOHC	40-44/ 54-60					
PN46	1720	4	78.00	Indirect Injection, SOHC	41-42/ 56-57					
PN62	1720	4	78.00	Indirect Injection, SOHC	41-43/ 56-58					
PN	1720	4	78.00							
323 1.8L 16V						08/89 → 07/94	56	BS950 (MLS) (30-028007-00)	DS950 (21-28007-20/0)	GS950 (20-28007-00/0)
323 1.8L 16V 4WD						09/91 → 07/94				
BP52	1840	4	83.00	DOHC	76/103					
BP	1840	4	83.00	DOHC	76-78/ 103- 106					

								 AB5010, AB5020, AB5030
		JC666  JC784 	JN628 (50-028048-00)	JJ354	PA883 (x8)	 NJ324 (x2) 34x48x7mm, ACM  NJ448  30x44x7mm, NBR  NJ650  83x100x9mm, ACM		 BP570
HBS136  (22-18009B) M11x1.50x104.5mm (x10)	JD5754  JD331 					 NA5246  42.5x54.5x6mm		 BP600
HBS406 (22-75007B)								 BS070
HBS406 (22-75007B)	JD5753  JC781  1988 →		JJ354	PA956 (x16)	 NJ324 (x2) 34x48x7mm, ACM  NJ448  30x44x7mm, NBR  NK158  37x50.5x7mm, ACM  NJ650  83x100x9mm, ACM			 BS950
HBS406 (22-75007B)	JD5753 	JN774		PA956 (x16)	 NJ324 (x2) 34x48x7mm, ACM  NJ448  30x44x7mm, NBR  NK158  37x50.5x7mm, ACM  NJ650  83x100x9mm, ACM			 BV110
HBS406 (22-75007B)	JC666  JC784 	JN628 (50-028048-00)	JJ354	PA883 (x8)	 NJ324 (x2) 34x48x7mm, ACM  NJ448  30x44x7mm, NBR  NJ650  83x100x9mm, ACM			 JC664
HBS406 (22-75007B)	JC666  JC664  →12/87 JC784  01/88 →  JE102	JN628 (50-028048-00)	JJ354	PA956 (x8) →12/86 PA883 (x8) 01/87 →	 NJ448 30x44x7mm, NBR  NJ448  30x44x7mm, NBR  NJ650  83x100x9mm, ACM			 JC666
HBS406 (22-75007B)	JC781 		JJ354	PA956 (x16)	 NJ324 (x2) 34x48x7mm, ACM  NJ448  30x44x7mm, NBR  NJ650  83x100x9mm, ACM			 JC781
HBS036  (22-29001B) M12x1.5x102mm (x10)	JD303  JD5914  JD304 	JN777 (50-027776-00)		PA658 (x8) (50-319265-00)	 NJ449 40x52x6mm, NBR (50-319266-00)  NJ450  45x68x12mm, NBR  NJ449  40x52x6mm, NBR (50-319266-00)  NK092  87x100x7mm, FPM			 JN628
HBS211  (22-75001B) M12x1.50x113mm (x10)		JN710		PA883 (x8)	 NJ448  30x44x7mm, NBR  NJ650  83x100x9mm, ACM			 JN710
HBS136  (22-18009B) M11x1.50x104.5mm (x10)		JN775 (50-028056-00)		PA956 (x16)	 NJ324 (x2) 34x48x7mm, ACM  NJ448  30x44x7mm, NBR  NJ650  83x100x9mm, ACM			 JN774
								 JN777
								 JJ354

MAZDA



KW/PS

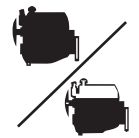

323 1.8L 16V					08/94 → 09/98	57	BS950 (MLS) (30-028007-00)	CG5370	
BP-ZE	1840	4	83.00	Injection, DOHC	84-103/ 114- 140				
323 1.8L 16V GT					06/89 → 07/94	58	BS950 (MLS) (30-028007-00)	DS950 (21-28007-20/0)	
323 1.8L 16V Turbo 4WD					09/90 → 07/94				
BP (DOHC)	1840	4	83.00	L-Jetronic, DOHC	94/128				
323 1.8L 16V GT					08/89 → 07/94	59	BS950 (MLS) (30-028007-00)	DS950 (21-28007-20/0)	GS950 (20-28007-00/0)
323 1.8L 4WD					01/91 → 04/94				
BP52	1840	4	83.00	DOHC	76/103				
BP	1840	4	83.00	DOHC	76-78/ 103- 106				
BP (DOHC)	1840	4	83.00	L-Jetronic, DOHC	94/128				
323 1.8L 16V Mk IV					09/89 → 03/93	60			GS953
BP22/BP31	1840	4	83.00	DOHC	103/140				
323 1.9L 16V					09/98 → 05/04	61	BS950 (MLS) (30-028007-00)	CG5370	
BP-ZE	1840	4	83.00	Injection, DOHC	84-103/ 114- 140				
323 2.0L					01/01 → 05/04	62	BV380 (MLS) (30-028871-00)	DV380	
FS7E/FS7G	1991	4	83.00		96/131				
323 2.0L 24V					08/94 → 09/98	63	BX790 (MLS) BX780 (MLS)		
KF	1995	6	78.00	Injection, DOHC	105- 106/ 143- 144				
323 2.0L D Diesel					10/96 → 05/04	64	AG5130 (MLS), 1.5mm		
RF1G	1998	4			52/71				
	1998	4	86.00	SOHC	52/71				
323 2.0L DiTD Mk VI Diesel					10/00 → 10/02	65		CG8191	
RF4F	1998	4	86.00	Direct Injection	74/100				
323 2.0L TD Diesel					09/98 → 05/04	66	AG8190 (MLS) RF	CG8191	
RF4F	1998	4			66/90				
	1998	4	86.00	Direct Injection	74/100				
323 2.0L TD Diesel					09/98 → 05/04	67	AG8190 (MLS) → 01/01 RF	CG8191	
	1998	4			66/90				
626 1.6L					11/82 → 09/87	68	BM300 (Fibre) (30-026716-10)	DM300	GM300
F6	1587	4	81.00	Injection, SOHC	59-66/ 80-90				
626 1.8L					05/97 → 10/02	69	BV380 (MLS) (30-028871-00)	CG5390	GV380
FP9A	1840	4	83.00		74/100				
FP	1840	4	83.00	Injection, DOHC	74-84/ 100- 114				
626 1.8L					08/91 → 04/97	70	BV380 (MLS) (30-028871-00)		GV380
626 1.8L i					01/92 → 04/97				
FP	1840	4	83.00	Injection, DOHC	74-84/ 100- 114				
626 1.8L					11/87 → 05/92	71	BR730 (Graphite) (30-027999-00)	DR736	GR736
626 Coupe 1.8L					09/87 → 08/91				
F8	1789	4	86.00		65/88				

						NK158 37x50.5x7mm, ACM			BM300 BR730 BS950 BV380 BX780 BX790 JC400 JC401 JC777 JN533 JN692 JN813 JN814 JJ268	
HBS136 ® [22-18009B] M11x1.50x104.5mm (x10)										
HBS136 ® [22-18009B] M11x1.50x104.5mm (x10)										
HBS136 ® [22-18009B] M11x1.50x104.5mm (x10) HBS406 [22-75007B]		JN775 (50-028056-00)		PA956 (x16)	NJ324 (x2) 34x48x7mm, ACM NJ448 30x44x7mm, NBR NJ650 83x100x9mm, ACM					
HBS136 ® [22-18009B] M11x1.50x104.5mm (x10)						NK158 37x50.5x7mm, ACM				
HBS136 ® [22-18009B] M11x1.50x104.5mm (x10)	JD5754 ■ JD331 ■					NA5246 42.5x54.5x6mm				
	JD5756 ■ JD5755 ■	JN832 JN833		PB313 (x12) PB314 (x12)	NA5246 42.5x54.5x6mm					
HBS211 © [22-75001B] M12x1.50x113mm (x10)										
HBS289 © [22-75005B] M12x1.50x113mm (x10)		JM5315 RF								
HBS289 © [22-75005B] M12x1.50x113mm (x10)		JM5315 →01/01 RF								
	JC401 ■ JC400 ■ JF017	JN533 (50-026764-00)	JJ268	KJ710 (x8)	NJ324 34x48x7mm, ACM NJ325 90x110x9mm, MVQ					
HBS136 ® [22-18009B] M11x1.50x104.5mm (x10)	JD5754 ■ JD331 ■				NA5246 42.5x54.5x6mm					
HBS136 ® [22-18009B] M11x1.50x104.5mm (x10)	JD5754 ■ JD331 ■	JN813 ■ (31-028588-00) JN814 ■ (31-028589-00)			NA5246 42.5x54.5x6mm NK205 89x109x10.3mm, MVQ					
	JC777 ■	JN692 (50-028050-00)	JJ268	PA883 (x12)	NJ324 34x48x7mm, ACM NJ325 90x110x9mm, MVQ					

MAZDA



KW/PS



626 2.0L					04/98 → 10/02	72	BV380 (MLS)	DV380	
626 2.0L H.P.					02/98 → 10/02		(30-028871-00)		
FS2C	1991	4	83.00			100/136			
626 2.0L					03/83 → 09/87	73	BL320 (Fibre)	DL321	GL321
FE	1998	4	86.00	SOHC		66-88/ 90-120	(30-026717-10)		
626 2.0L					09/87 → 10/90	74	BL320 (Fibre)		
FE	1998	4	86.00	SOHC		66-88/ 90-120	(30-026717-10) BR730 (Graphite) (30-027999-00)		
626 2.0L					10/88 → 09/97	75	BL320 (Fibre)	DR850	GR850
FE	1998	4	86.00	SOHC		66-88/ 90-120	(30-026717-10) BR850 (Graphite) (30-028000-00)	(21-28000-20/0)	(20-28000-00/0)
626 2.0L Diesel					01/82 →	76	BN620 (Fibre)	DN622	GM730
RF OHC	1998	4	86.00	Indirect Injection, SOHC		55/75		01/86 →	→ 12/85 GN622 01/86 →
626 2.0L					05/97 → 10/02	77	BV380 (MLS)	DV380	
626 2.0L i					08/91 → 04/97		(30-028871-00)		
626 2.0L i 4WD					04/92 → 04/97				
FS	1991	4	83.00	DOHC		85/116			
626 2.0L					02/98 → 10/02	78	BV380 (MLS)	DV380	
FS	1991	4	83.00	DOHC		85/116	(30-028871-00)		
626 2.0L 12V					09/87 → 05/92	79	BR730 (Graphite)	DR730	GR730
626 Coupe 2.0L 12V					09/87 → 12/88		(30-027999-00)		
FE (12V)	1984	4	86.00			79-81/ 107- 110			
626 2.0L 16V					06/87 → 05/92	80	BR850 (Graphite)	DR850	GR850
626 Coupe 2.0L 16V					06/87 → 10/90		(30-028000-00)	(21-28000-20/0)	(20-28000-00/0)
FE Kat. (16V)	1998	4	86.00			103- 109/ 140- 148			
626 2.0L D Diesel					07/87 → 07/91	81	AG5130 (MLS), 1.5mm		
RF-N	1998	4	86.00	Indirect Injection		44/60			
626 2.0L D Diesel					11/94 → 09/97	82	AG5130 (MLS), 1.5mm	CG5460	
626 2.0L D GLX Comprex Diesel					10/92 → 04/97				
RF OHC	1998	4	86.00	Indirect Injection, SOHC		55/75			
RF G5	1998	4	86.00	SOHC		55/75			
626 2.0L D Comprex Diesel					05/93 → 11/96	83	AG5130 (MLS), 1.5mm	CG5460	EG5130 FG5130
RF-CX	1998	4	86.00	Indirect Injection		55/75			
626 2.0L DITD Diesel					04/98 → 10/02	84	AG8190 (MLS)	CG8191	
626 2.0L Turbo DI Diesel					04/98 → 10/02				
RF3F	1998	4	86.00	Direct Injection		66/89			
RF4F	1998	4	86.00	Direct Injection		74/100			
626 2.0L TD Diesel					10/00 → 10/02	85	AG8190 (MLS)	CG8191	
626 2.0L Turbo DI Diesel					04/98 → 10/02				
	1998	4				74/101			
	1998	4				81/110			

HBS136 ® (22-18009B) M11x1.50x104.5mm (x10)	JD5754 ■ JD331 ■				<input checked="" type="checkbox"/> NA5246 ■ 42.5x54.5x6mm		 BL320
	JC401 ■ 09/82→ HA399 ■ JC400 ■	JN533 (50-026764-00)	JJ268	KJ710 (x8)	<input checked="" type="checkbox"/> NJ324 34x48x7mm, ACM <input checked="" type="checkbox"/> NJ324 ■ 34x48x7mm, ACM <input checked="" type="checkbox"/> NJ325 ■ 90x110x9mm, MVQ		 BN620
			JJ268		<input checked="" type="checkbox"/> NJ324 34x48x7mm, ACM <input checked="" type="checkbox"/> NJ324 ■ 34x48x7mm, ACM <input checked="" type="checkbox"/> NJ325 ■ 90x110x9mm, MVQ		 BR730
		JN717 (50-028065-00)	JJ268		<input checked="" type="checkbox"/> NJ324 34x48x7mm, ACM <input checked="" type="checkbox"/> NJ324 ■ 34x48x7mm, ACM <input checked="" type="checkbox"/> NJ325 ■ 90x110x9mm, MVQ		 BR850
HBS211 ⊙ (22-75001B) M12x1.50x113mm (x10)	JC598 ■ JC477 ■	JN576 (50-026765-00)	JJ268	PA659 (x8)	<input checked="" type="checkbox"/> NJ448 30x44x7mm, NBR <input checked="" type="checkbox"/> NJ324 ■ 34x48x7mm, ACM <input checked="" type="checkbox"/> NJ325 ■ 90x110x9mm, MVQ		 BV380
HBS136 ® (22-18009B) M11x1.50x104.5mm (x10)	JD5754 ■ JD331 ■	JN877		PB313 (x8) PB314 (x8)	<input checked="" type="checkbox"/> NA5246 ■ 42.5x54.5x6mm <input checked="" type="checkbox"/> NK205 ■ 89x109x10.3mm, MVQ		 JC400
HBS136 ® (22-18009B) M11x1.50x104.5mm (x10)	JD5754 ■ JD331 ■				<input checked="" type="checkbox"/> NA5246 ■ 42.5x54.5x6mm <input checked="" type="checkbox"/> NK205 ■ 89x109x10.3mm, MVQ		 JC401
		JN692 (50-028050-00)	JJ268		<input checked="" type="checkbox"/> NJ324 34x48x7mm, ACM <input checked="" type="checkbox"/> NJ324 ■ 34x48x7mm, ACM <input checked="" type="checkbox"/> NJ325 ■ 90x110x9mm, MVQ		 JC477
		JN717 (50-028065-00)	JJ268	PA956 (x16)	<input checked="" type="checkbox"/> NJ324 (x2) 34x48x7mm, ACM <input checked="" type="checkbox"/> NJ324 ■ 34x48x7mm, ACM <input checked="" type="checkbox"/> NJ325 ■ 90x110x9mm, MVQ		 JC598
HBS211 ⊙ (22-75001B) M12x1.50x113mm (x10)							 JN533
HBS211 ⊙ (22-75001B) M12x1.50x113mm (x10)							 JN576
HBS211 ⊙ (22-75001B) M12x1.50x113mm (x10)							 JN692
HBS289 ⊙ (22-75005B) M12x1.50x113mm (x10)							 JN717
HBS289 ⊙ (22-75005B) M12x1.50x113mm (x10)		JM5315					 JJ268

MAZDA



KW/PS

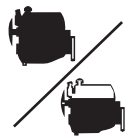

626 Coupe 2.0L				09/87 → 10/90		86	BL320 (Fibre) (30-026717-10)	DR732 (21-27999-22/0)	
FE	1998	4	86.00	SOHC		66-88/ 90-120	BR730 (Graphite) (30-027999-00)		
626 2.2L 12V				11/87 → 04/92		87	BR730 (Graphite) (30-027999-00)	DR732 (21-27999-22/0) → 12/90	GR732 → 12/90
626 2.2L 12V 4WD				05/91 → 11/92				DR734 01/91 →	GR734 01/91 →
F2	2184	4	86.00	injection, SOHC		85/115			
F2L1	2184	4	86.00	SOHC		85/115			
626 2.2L 12V				03/89 → 11/96		88	BR730 (Graphite) (30-027999-00)	DR730 DR732 (21-27999-22/0) → 12/90	GR730 GR732 → 12/90
626 Coupe 2.2L 12V				04/88 → 12/91				DR734 01/91 →	GR734 01/91 →
F2	2184	4	86.00	injection, SOHC		85/115			
626 2.2L 12V 4WD				11/87 → 07/90		89	BR730 (Graphite) (30-027999-00)	DR732 (21-27999-22/0)	GR732
F2	2184	4	86.00	injection, SOHC		85/115			
626 2.5L 24V				01/92 → 04/97		90	BV410 (MLS)	DV410	
KL	2497	6	84.50	L-Jetronic, DOHC, V6		120- 123/ 163- 167	BV420 (MLS)		
929 2.0L				05/79 → 12/87		91	AJ120 (Graphite) (30-026177-10)	CJ127	FJ127
929 Coupe 2.0L				05/82 → 03/84				1982 →	1982 →
HEE	1970	4	80.00	SOHC		66/89			
M	1970	4	80.00			66/89			
MA	1970	4	80.00	SOHC		66/89			
929 2.0L				03/84 → 07/87		92	BL320 (Fibre) (30-026717-10)	DL321	GL321
929 2.0L i GLX				10/84 → 07/87					
929 Coupe 2.0L				03/84 → 07/87					
929 Coupe 2.0L i				10/84 → 07/87					
FE	1998	4	86.00	SOHC		66-88/ 90-120			
929 2.0L				06/87 → 12/88		93	BL320 (Fibre) (30-026717-10)	DR850 (21-28000-20/0)	GR850 (20-28000-00/0)
FE	1998	4	86.00	SOHC		66-88/ 90-120	BR850 (Graphite) (30-028000-00)		
FEFA	1998	4	86.00	SOHC		85/116			
929 2.2L 12V				04/89 → 06/91		94	BR730 (Graphite) (30-027999-00)	DR730	GR730
F2-C	2184	4	86.00			94/128			
929 2.2L 12V				01/88 → 04/89		95	BR730 (Graphite) (30-027999-00)	DR732 (21-27999-22/0)	GR732
F2	2184	4	86.00	injection, SOHC		85/115			
F21	2184	4	86.00	SOHC		85/115			
F2E	2184	4	86.00	SOHC		85/116			
929 2.2L i				05/87 → 12/88		96	BR730 (Graphite) (30-027999-00)	DR732 (21-27999-22/0)	
F2-EGI	2184	4	86.00	Injection, SOHC		100/136			

				JJ268		<input checked="" type="checkbox"/> NJ324 34x48x7mm, ACM <input checked="" type="checkbox"/> NJ324F 34x48x7mm, ACM <input checked="" type="checkbox"/> NJ325R 90x110x9mm, MVQ							
	JC779I JC777E →12/90 JC778E (x2) →12/90 JC400E 01/91→ ⊙JE102 ⊙JE185 ⊙JF017	JN692 (50-028050-00)	JJ268	PA883 (x12)	<input checked="" type="checkbox"/> NJ324 34x48x7mm, ACM <input checked="" type="checkbox"/> NJ324F 34x48x7mm, ACM <input checked="" type="checkbox"/> NJ325R 90x110x9mm, MVQ								
	JC779I JC777E →12/90 JC778E (x2) →12/90 JC400E 01/91→ ⊙JE102 ⊙JE185 ⊙JF017	JN692 (50-028050-00)	JJ268	PA883 (x12)	<input checked="" type="checkbox"/> NJ324 34x48x7mm, ACM <input checked="" type="checkbox"/> NJ324F 34x48x7mm, ACM <input checked="" type="checkbox"/> NJ325R 90x110x9mm, MVQ								
	JC779I JC777E JC778E (x2) ⊙JE102 ⊙JE185 ⊙JF017	JN692 (50-028050-00)	JJ268	PA883 (x12)	<input checked="" type="checkbox"/> NJ324 34x48x7mm, ACM <input checked="" type="checkbox"/> NJ324F 34x48x7mm, ACM <input checked="" type="checkbox"/> NJ325R 90x110x9mm, MVQ								
HBS288⊙ (22-75006B) M12x1.50x113mm (x10) M10x1.25x100mm (x8) C	JD5756I JD5755E	JN832 JN833		PB313 (x12) PB314 (x12)	<input checked="" type="checkbox"/> NA5246E 42.5x54.5x6mm								
	JA021I JC251E (x2) 10/80→12/81 ⊙JE674 10/80→12/81	JM019 HL509E (24-28044-00/0)	JH015	KJ710 (x8)	<input checked="" type="checkbox"/> NJ042E 48x70x12mm, NBR <input checked="" type="checkbox"/> NJ040R 80x105x13mm, MVQ								
	JC401I 09/82→ HA399E JC400E	JN533 (50-026764-00)	JJ268	KJ710 (x8)	<input checked="" type="checkbox"/> NJ324 34x48x7mm, ACM <input checked="" type="checkbox"/> NJ324F 34x48x7mm, ACM <input checked="" type="checkbox"/> NJ325R 90x110x9mm, MVQ								
		JN717 (50-028065-00)	JJ268	PA956 (x16)	<input checked="" type="checkbox"/> NJ324 (x2) 34x48x7mm, ACM <input checked="" type="checkbox"/> NJ324F 34x48x7mm, ACM <input checked="" type="checkbox"/> NJ325R 90x110x9mm, MVQ								
	JC779I JC777E JC778E (x2) ⊙JE102 ⊙JE185 ⊙JF017	JN692 (50-028050-00)	JJ268	PA883 (x12)	<input checked="" type="checkbox"/> NJ324 34x48x7mm, ACM <input checked="" type="checkbox"/> NJ324F 34x48x7mm, ACM <input checked="" type="checkbox"/> NJ325R 90x110x9mm, MVQ								

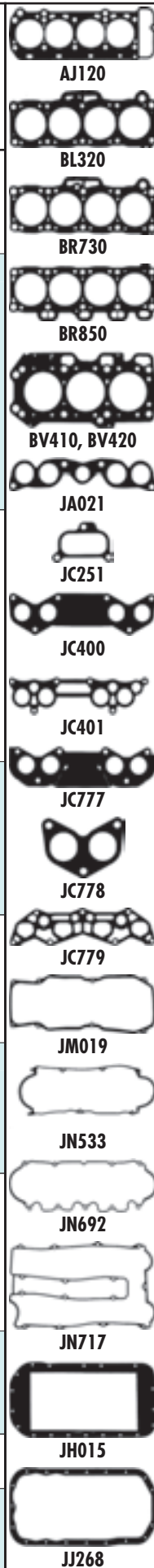







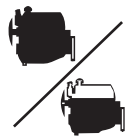



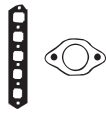

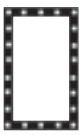



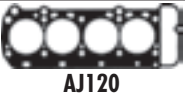

















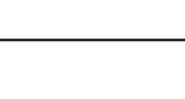

























































MAZDA



KW/PS



929 3.0L 01/88 → 06/91 97					BR970 (MLS)		
JE3	2954	6	90.00	SOHC, V6	123-125/ 167-170		
929 3.0L 06/87 → 06/91 98					BR970 (MLS)		
JE	2954	6	90.00	DOHC, V6	140/190		
Bongo 2200 Diesel 09/79 → 12/90 99					AJ630 (Graphite)	CJ631 (21-27991-20/0) → 07/82	FJ631 → 07/82
S2	2209	4	88.90	Indirect Injection	51-52/ 70-71	CJ633 08/82 →	FJ632 08/82 →
B-Serie 2000 01/81 → 100					AJ120 (Graphite) (30-026177-10)		
MA (California)	1970	4	80.00	SOHC	66/89		
B-Serie 2.2L 08/91 → 12/96 101					BR730 (Graphite) (30-027999-00)		
B-Serie 2.2L 4WD 02/99 →							
B-Serie 2.2L 8V 4WD 06/99 →							
JL22	2148	4	86.00		68/92		
R5A2	2184	4	86.00		60/81		
F2L8	2184	4	86.00	SOHC	68/92		
B-Serie 2.2L D Diesel 01/85 → 03/96 102					BN620 (Fibre)	DN621 (21-25236-21/0)	
R290	2184	4	86.00	Indirect Injection, SOHC	44-47/ 60-64		
B-Serie 2200 01/86 → 103					BR730 (Graphite) (30-027999-00)	DR731	GR731
F2-L	2184	4	86.00	SOHC			
B-Serie 2200 Diesel 09/79 → 12/90 104					AJ630 (Graphite)	CJ631 (21-27991-20/0) → 07/82	FJ631 → 07/82
S2	2209	4	88.90	Indirect Injection	51-52/ 70-71	CJ633 08/82 →	FJ632 08/82 →
B-Serie 2.5L D Diesel 06/99 → 105					AA5130 (MLS) (30-029438-00)	CA5130 (21-29438-20/0)	FA5130 (20-29438-00/0)
B-Serie 2.5L D 4WD Diesel 02/96 → 06/99							
B-Serie 2.5L TD 4WD Diesel 06/99 →							
WLE7	2500	4	93.00	Indirect Injection, SOHC	62/84		
MD25NA	2500	4	94.00	Indirect Injection	57/77		
MD25TI	2500	4	94.00	Indirect Injection	80/109		
B-Serie 2500 01/89 → 106					BS280 (Graphite) (30-028005-00)	DS280 (21-28005-20/0)	GS280
AM	2555	4	91.10	SOHC			
Capella 2000 Diesel 01/82 → 107					BN620 (Fibre)	DN622 01/86 →	GM730 → 12/85
RF OHC	1998	4	86.00	Indirect Injection, SOHC	55/75	GN622 01/86 →	
Cosmo 2000 Diesel 01/82 → 108					BN620 (Fibre)	DN622 01/86 →	GM730 → 12/85
RF OHC	1998	4	86.00	Indirect Injection, SOHC	55/75	GN622 01/86 →	
Demio 1.2L 02/03 → 109						CB5120 (21-29248-00/0)	EB5120
FUJA	1242	4	71.90	DOHC	55/75		
Demio 1.3L 16V 08/98 → 04/00 110					AG9080 (MLS), 1.20mm		
B3 (16V)	1324	4	71.00	Injection	53-54/ 72-73		

								 AJ120  AJ630  BN620  BR730  BR970, BR980  BS280  BS460  JA021  JC400  JC401  JC477  JC598  JC775  JC931  JM019  JN533  JN576  JN595  JN714  JH015  JJ268
		JC931 	JN714 (x2)		KJ710  (x6) PA956  (x12)	 NJ985 (x2) 35x49.6x11mm, NBR  NJ978  46x60x7mm, MVQ  NK035  75x93x9mm, MVQ		
		JC775  (x4) →07/82 JA052  (x4)	JN595		PA426 (x8)	 NJ367  51x70x11mm, NBR  NJ330  101.6x125x13mm, MVQ		
		JA021   JE674	JM019 HL509  <i>(24-28044-00/0)</i>	JH015	KJ710  (x8)	 NJ042  48x70x12mm, NBR  NJ040  80x105x13mm, MVQ		
HBS211  <i>(22-75001B)</i> M12x1.50x113mm (x10)								
		JC401  HA399  JC400 	JN533 <i>(50-026764-00)</i>	JJ268		 NJ324 34x48x7mm, ACM  NJ324  34x48x7mm, ACM  NJ325  90x110x9mm, MVQ		
		JC775  (x4) →07/82 JA052  (x4)	JN595		PA426 (x8)	 NJ367  51x70x11mm, NBR  NJ330  101.6x125x13mm, MVQ		
HBS288  <i>(22-75006B)</i> M12x1.50x113mm (x10) M10x1.25x100mm (x8)		JD5131  JD5132 				 NA5196  53x69.85x11mm, MVQ		
					PA883  (x12)	 NJ978  46x60x7mm, MVQ		
HBS211  <i>(22-75001B)</i> M12x1.50x113mm (x10)		JC598  JC477 	JN576 <i>(50-026765-00)</i>	JJ268	PA659 (x8)	 NJ448 30x44x7mm, NBR  NJ324  34x48x7mm, ACM  NJ325  90x110x9mm, MVQ		
HBS211  <i>(22-75001B)</i> M12x1.50x113mm (x10)		JC598  JC477 	JN576 <i>(50-026765-00)</i>	JJ268	PA659 (x8)	 NJ448 30x44x7mm, NBR  NJ324  34x48x7mm, ACM  NJ325  90x110x9mm, MVQ		
		JD5866  <i>(50-030340-00)</i>						
HBS406 <i>(22-75007B)</i>		JD5753 				 NK158  37x50.5x7mm, ACM		

MAZDA



KW/PS

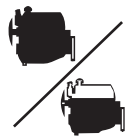

Demio 1.4L 02/03 → 111							CB5132 (21-29249-10/0)	EB5120
FXJA	1388	4	76.00	DOHC	59/80			
Demio 1.5L 16V 04/00 → 112						AG7850 (MLS)	CG7850	
B5	1498	4			55/75			
Demio 1.6L 02/03 → 113						AG9560 (MLS) (30-030341-00)		EB5120
FYJA	1596	4	79.00	DOHC	74/100			
E 2000 2000 11/84 → 02/88 114						BL320 (Fibre) (30-026717-10)	DL321	
E 2000 Van 2000 05/85 → 04/89								
FE18/FE58	1998	4	86.00	Carburettor, SOHC	63/86			
FEV4	1998	4	86.00	SOHC	63/86			
E 2000 2000 Diesel 01/82 → 115						BN620 (Fibre)	DN620	GN620
E 2000 Van 2000 Diesel 01/82 →						BS460 (Graphite) (30-025236-20)		
RF OHC	1998	4	86.00	Indirect Injection, SOHC	55/75			
E 2000 2000 4WD 10/88 → 09/89 116						BR850 (Graphite) (30-028000-00)	DR850 (21-28000-20/0)	GR850 (20-28000-00/0)
E 2000 Van 2000 03/91 → 05/94								
FE60/FE61	1998	4	86.00	Carburettor, SOHC	60/81			
FEBN	1998	4	86.00	SOHC	60-63/ 82-86			
E 2200 2.2L D Diesel 01/84 → 02/88 117						BN620 (Fibre)	DN621 (21-25236-21/0)	
E 2200 Van 2.2L D Diesel 05/85 → 02/88						BS460 (Graphite) (30-025236-20)		
E 2200 Van 2.2L D 4WD Diesel 03/91 →						AG5110 (MLS), 1.5mm		
R203/R207	2169	4	86.00	Indirect Injection	46-47/ 63-64			
E 2200 2.2L D Diesel 09/79 → 12/90 118						AJ630 (Graphite)	CJ631 (21-27991-20/0) → 07/82 CJ633 08/82 →	FJ631 → 07/82 FJ632 08/82 →
S2	2209	4	88.90	Indirect Injection	51-52/ 70-71			
E 2200 2.2L D Diesel 01/84 → 119						BS460 (Graphite) (30-025236-20)	DN621 (21-25236-21/0) 11/86 →	GN621 (20-25236-01/0) 11/86 →
E 2200 Van 2.2L D Diesel 01/84 →						BN620 (Fibre) 11/86 →		
R2	2184	4	86.00		52/71			
E 2200 Van 2.2L D Diesel 02/97 → 08/02 120						BN620 (Fibre)	DN621 (21-25236-21/0)	GN621 (20-25236-01/0)
E 2200 Van 2.2L D 4WD Diesel 02/97 →						BS460 (Graphite) (30-025236-20)		
R2	2184	4	86.00		52/71			
E 3000 3000 Diesel 03/77 → 01/84 121						BE360 (Graphite) → 09/80	DE360 → 09/80	GE360 → 09/80
E 3000 Van 3000 Diesel 03/77 → 01/84						BL880 (Graphite) (30-027993-00) 10/80 →	DL880 10/80 →	GL880 10/80 → 01/84
HA	2977	4	95.00		50-66/ 68-90			
Familia 1300 11/80 → 10/85 122						BJ430 (Graphite) (30-026179-10)	DJ430 → 11/82 DJ431 12/82 → 12/84 DJ432 01/85 →	GJ430 → 11/82 GJ431 12/82 → 12/84 GJ432 01/85 →
E3	1296	4	77.00	SOHC	44-55/ 60-75			

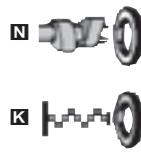
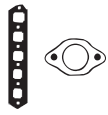

AJ630



JJ268



BE360

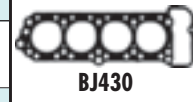

BJ430

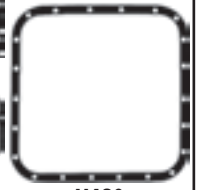

JJ420

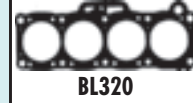

BL320



BL880

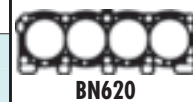

BN620

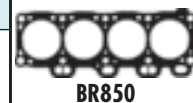

BR850

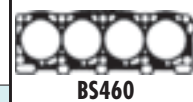

BS460



JC163



JC183



JC250



JC477



JC551



JC598



JC642



JC775



JN396



JN576



JN595

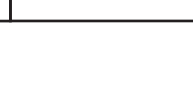

JJ149

	JD5866 (50-030340-00)								
HBS406 (22-75007B)	JD5753				NK158 37x50.5x7mm, ACM				
	JD5866 (50-030340-00) JD5865 (31-030338-00)								
HBS211 (22-75001B) M12x1.50x113mm (x10)	JC598 JC477	JN576 (50-026765-00)	JJ268	PA659 (x8)	NJ448 30x44x7mm, NBR NJ325 90x110x9mm, MVQ				
HBS211 (22-75001B) M12x1.50x113mm (x10)									
	JC775 (x4) →07/82 JA052 (x4)	JN595		PA426 (x8)	NJ367 51x70x11mm, NBR NJ330 101.6x125x13mm, MVQ				
HBS211 (22-75001B) M12x1.50x113mm (x10)	JC598 11/86 → JC477 11/86 → JE102 11/86 →	JN576 (50-026765-00) 11/86 →	JJ268 11/86 →	PA659 (x8)	NJ324 34x48x7mm, ACM NJ324 34x48x7mm, ACM NJ325 90x110x9mm, MVQ				
HBS211 (22-75001B) M12x1.50x113mm (x10)	JC477 JE101	JN576 (50-026765-00)	JJ268	PA659 (x8)	NJ448 30x44x7mm, NBR NJ324 34x48x7mm, ACM NJ325 90x110x9mm, MVQ				
	JC775 (x4) →09/80 JA052 (x4) →09/80 JC443 (x4) 10/80 →	JN553 10/80 →	JJ420 10/80 →	PA606 (x4) 10/80 →	NJ367 51x70x11mm, NBR NJ330 101.6x125x13mm, MVQ				
	JC183 →11/82 JC551 12/82 →12/84 JC642 01/85 → JC163 (x2) →11/82 JC250 12/82 →	JN396 (50-026180-00) HL508	JJ149		NB384 40x55x8mm, NBR NJ099 70x88x12mm, MVQ				

MAZDA



KW/PS



Familia 1300						01/91 →	123	BV430 (Graphite)	DV431	GV431
B3 (1.6V)	1324	4	71.00	Injection		39-40/ 53-54				
Familia 1700 Diesel						01/87 →	124	BS070 (Graphite)	DS070	
PN	1720	4	78.00				(30-028004-00)			
Luce 1800						01/70 → 12/78	125	AJ230 (Graphite)	CJ232	FJ232
VB	1796	4	78.00			73/99			→12/75	→12/75
Luce 3000						06/87 → 06/91	126	BR970 (MLS)		
JE	2954	6	90.00	DOHC, V6		140/190		BR980 (MLS)		
MPV 2.0L DI Mk II Diesel						07/02 →	127		CG8190	FG8190
RF5C	1998	4	86.00	Direct Injection		89/121				
MPV 2.0L						09/99 → 07/02	128	BV380 (MLS)	DV380	
FS	1991	4	83.00	DOHC		85/116	(30-028871-00)			
FS-DS	1991	4	83.00	DOHC		90/122				
MPV 2.3L						07/02 →	129	AD5220 (MLS)		
	2261	4				104/141	(30-029824-00)			
MPV 2.5L TD Diesel						05/96 → 09/99	130	AA5130 (MLS)	CA5130	FA5130
WL-T	2499	4	93.00	SOHC		85/116	(30-029438-00)		(21-29438-20/0)	(20-29438-00/0)
MPV 2.5						01/89 →	131	BS280 (Graphite)	DS280	GS280
AM	2555	4	91.10	SOHC			(30-028005-00)		(21-28005-20/0)	
MPV 3.0L i V6						03/95 → 09/99	132	BR970 (MLS)		
JE94	2954	6	90.00	Injection, V6		109/148		BR980 (MLS)		
MPV 3.0L V6						06/87 → 06/91	133	BR970 (MLS)		
JE	2954	6	90.00	DOHC, V6		140/190		BR980 (MLS)		
MX-3 Coupe 1.6L 16V						08/91 →	134	BS940 (Graphite)	DS940	GS940
B6E	1598	4	78.00	Carburettor, SOHC		62-63/ 84-86	(30-028006-00)		(21-28006-20/0)	
MX-3 Coupe 1.6L i						07/91 →	135	BV110 (Fibre)		
B69	1598	4	78.00	Injection		65-66/ 88-90				
MX-3 Coupe 1.6L i						01/94 →	136	BV110 (Fibre)	DV110	
B6D	1598	4	78.00	Injection		79/107			(21-28009-20/0)	
MX-5 1.6L 16V						08/91 →	137	BS940 (Graphite)	DS940	GS940
B6E	1598	4	78.00	Carburettor, SOHC		62-63/ 84-86	(30-028006-00)		(21-28006-20/0)	
MX-5 Convertible 1.6L						01/95 → 04/98	138	BV110 (Fibre)	DV110	
	1598	4				66/90			(21-28009-20/0)	
MX-5 Convertible 1.6L 16V						05/98 → 10/05	139	BV110 (Fibre)	DV110	GS941
	1598	4				81/110			(21-28009-20/0)	
MX-5 Convertible 1.8L						02/94 → 04/98	140	BS950 (MLS)	CG5370	
MX-5 Convertible 1.8L 16V						05/98 → 10/05		(30-028007-00)		
BPZE	1840	4	83.00	Injection, DOHC		84-103/ 114- 140				
BPF1	1840	4	83.00	DOHC		96-98/ 130- 133				
MX-5 Convertible 1.9L 16V						11/00 → 10/05	141	BS953 (MLS)	CD5400	
	1840	4				102/139		BP		
	1840	4				107/146				

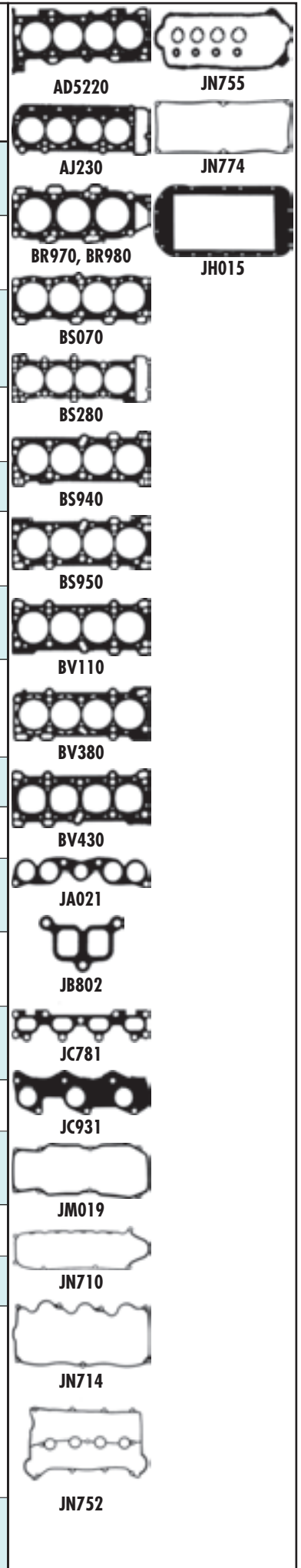
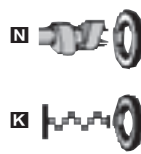
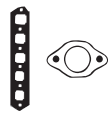

	JE101	JN774		PA956 (x16)	<input checked="" type="checkbox"/> NJ448F 30x44x7mm, NBR <input checked="" type="checkbox"/> NK157F 84x100x10mm, FPM	
HBS211® (22-75001B) M12x1.50x113mm (x10)		JN710		PA883 (x8)	<input checked="" type="checkbox"/> NJ448F 30x44x7mm, NBR <input checked="" type="checkbox"/> NJ650F 83x100x9mm, ACM	
	JA021 ■ JB802 ■ (x2) →12/75 JE674	JM019 HL509 ■ (24-28044-00/0)	JH015	KJ468 (x8)	<input checked="" type="checkbox"/> NJ042F 48x70x12mm, NBR <input checked="" type="checkbox"/> NJ040F 80x105x13mm, MVQ	
	JC931 ■ 08/88→			KJ710 ■ (x6) PA956 ■ (x6)	<input checked="" type="checkbox"/> NJ985 (x2) 35x49.6x11mm, NBR <input checked="" type="checkbox"/> NJ978F 46x60x7mm, MVQ <input checked="" type="checkbox"/> NK035F 75x93x9mm, MVQ	
		JM5314				
HBS136® (22-18009B) M11x1.50x104.5mm (x10)	JD5754 ■ JD331 ■				<input checked="" type="checkbox"/> NA5246F 42.5x54.5x6mm <input checked="" type="checkbox"/> NK205F 89x109x10.3mm, MVQ	
HBS369® (22-18095B) M10x1.50x145.5mm (x10)						
HBS288® (22-75006B) M12x1.50x113mm (x10) M10x1.25x100mm (x8)	JD5131 ■ JD5132 ■				<input checked="" type="checkbox"/> NA5196F 53x69.85x11mm, MVQ	
				PA883 ■ (x12)	<input checked="" type="checkbox"/> NJ978F 46x60x7mm, MVQ	
		JN714 (x2)		KJ710 ■ (x6) PA956 ■ (x6)	<input checked="" type="checkbox"/> NJ985 (x2) 35x49.6x11mm, NBR <input checked="" type="checkbox"/> NJ978F 46x60x7mm, MVQ <input checked="" type="checkbox"/> NK035F 75x93x9mm, MVQ	
	JC781 ■	JN752 (50-028055-00)		PA956 (x16)	<input checked="" type="checkbox"/> NJ324 (x2) 34x48x7mm, ACM <input checked="" type="checkbox"/> NJ448F 30x44x7mm, NBR <input checked="" type="checkbox"/> NJ650F 83x100x9mm, ACM	
HBS406 (22-75007B)	JD5753 ■				<input checked="" type="checkbox"/> NK158F 37x50.5x7mm, ACM	
		JM5296 B6ZE	HC5009 ■		<input checked="" type="checkbox"/> NK158F 37x50.5x7mm, ACM	
	JC781 ■	JN752 (50-028055-00)		PA956 (x16)	<input checked="" type="checkbox"/> NJ324 (x2) 34x48x7mm, ACM <input checked="" type="checkbox"/> NJ448F 30x44x7mm, NBR <input checked="" type="checkbox"/> NJ650F 83x100x9mm, ACM	
		JM5296 B6ZE	HC5009 ■		<input checked="" type="checkbox"/> NK158F 37x50.5x7mm, ACM	
		JM5296 B6ZE	HC5009 ■		<input checked="" type="checkbox"/> NK158F 37x50.5x7mm, ACM	
		JN755 (50-028119-00)	HC5009 ■		<input checked="" type="checkbox"/> NK158F 37x50.5x7mm, ACM	
					<input checked="" type="checkbox"/> NK158F 37x50.5x7mm, ACM	

MAZDA



KW/PS

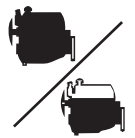

Model						Year	Power (KW/PS)	Engine	Code	Notes
MX-6 Coupe 2.0L						02/92 →	142	BV380 (MLS)	DV380	
FS	1991	4	83.00	DOHC		85/116	(30-028871-00)			
MX-6 2.2L Turbo						11/87 → 04/92	143	BR730 (Graphite)	DR732	GR732
F2	2184	4	86.00	injection, SOHC		85/115	(30-027999-00)	(21-27999-22/0) →12/90	GR734	→12/90 01/91 →
MX-6 Coupe 2.5L 24V						02/92 →	144	BV410 (MLS)	DV410	
KL	2497	6	84.50	L-Jetronic, DOHC, V6		120- 123/ 163- 167	BV420 (MLS)			
Pick Up 2.2L Diesel						09/79 → 12/90	145	AJ630 (Graphite)	CJ631	FJ631
S2	2209	4	88.90	Indirect Injection		51-52/ 70-71		(21-27991-20/0) →07/82	FJ632	→07/82 08/82 →
Premacy 1.8L						07/99 →	146	BV380 (MLS)	CG5390	GV380
FP	1840	4	83.00	Injection, DOHC		74-84/ 100- 114	(30-028871-00)			
Premacy 1.9L						07/99 →	147	BV380 (MLS)	CG5390	GV380
FP	1840	4	83.00	Injection, DOHC		74-84/ 100- 114	(30-028871-00)			
Premacy 2.0L						11/01 →	148	BV380 (MLS)	DV380	
FS7E/FS7G	1991	4	83.00			96/131	(30-028871-00)			
Premacy 2.0L TD Diesel						10/99 → 07/00	149	AG8190 (MLS)	CG8191	
RF3F	1998	4	86.00	Direct Injection		66/89	RF			
RF4F	1998	4	86.00	Direct Injection		74/100				
Telester 2000 Diesel						01/82 →	150	BN620 (Fibre)	DN622	GM730
RF OHC	1998	4	86.00	Indirect Injection, SOHC		55/75	BS460 (Graphite) (30-025236-20)	01/86 →	GN622	→12/85 01/86 →
Titan 3500 Diesel						02/84 →	151	BP840 (Graphite)	DP840	GP840
SL	3455	4	100.00	Injection		66-77/ 90-105				
Tribute 2.0L						03/00 →	152	AE5320 (MLS)	CE5320	EC5800
Tribute 2.0L AWD	1989	4				91/124	(30-029870-00)	(21-29870-20/0)	EC5800	(22-29400-00/0)
Xedos 6 1.6L 16V						06/94 →	153	BV110 (Fibre)	DV110	
B6	1597	4	78.00	DOHC		79/107		(21-28009-20/0)		
Xedos 6 1.6L 16V						08/91 →	154	BS940 (Graphite)	DS940	GS940
B6E	1598	4	78.00	Carburettor, SOHC		62-63/ 84-86	(30-028006-00)	(21-28006-20/0)		

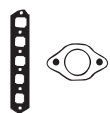

AE5320



JN692



AJ630

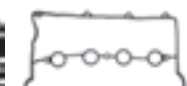

JN752



BN620



JH5061



BP840



JJ268



BR730

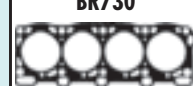

BS460



JJ386



BS940



BV110



BV380



BV410, BV420



JC400



JC477



JC598



JC775



JC777



JC778



JC779



JC781



JN576



JN595



HBS136®
(22-18009B)
M11x1.50x104.5mm (x10)

JD5754■
JD331■

JN692
(50-028050-00)

JJ268

PA883 (x12)

☒ NA5246■ 42.5x54.5x6mm
☒ NK205■ 89x109x10.3mm, MVQ

JC779■
→12/90
JC777■
→12/90
JC778■ (x2)
→12/90
JC400■
01/91→
☉JE102
→12/90
☉JE185
→12/90
☉JF017
→12/90

JN595

JJ268

PA426 (x8)

☒ NJ324 34x48x7mm, ACM
☒ NJ324■ 34x48x7mm, ACM
☒ NJ325■ 90x110x9mm, MVQ

JD5756■
JD5755■

JN595

JJ268

PA426 (x8)

☒ NA5246■ 42.5x54.5x6mm

JC775■ (x4)
→07/82
JA052■ (x4)

JN595

JJ268

PA426 (x8)

☒ NJ367■ 51x70x11mm, NBR
☒ NJ330■ 101.6x125x13mm, MVQ

HBS136®
(22-18009B)
M11x1.50x104.5mm (x10)

JD5754■
JD331■

JN595

JJ268

PA426 (x8)

☒ NA5246■ 42.5x54.5x6mm
☒ NK205■ 89x109x10.3mm, MVQ

HBS136®
(22-18009B)
M11x1.50x104.5mm (x10)

JD5754■
JD331■

JN595

JJ268

PA426 (x8)

☒ NA5246■ 42.5x54.5x6mm
☒ NK205■ 89x109x10.3mm, MVQ

HBS136®
(22-18009B)
M11x1.50x104.5mm (x10)

JD5754■
JD331■

JN595

JJ268

PA426 (x8)

☒ NA5246■ 42.5x54.5x6mm

HBS289®
(22-75005B)
M12x1.50x113mm (x10)

JM5315
RF

JN595

JJ268

PA659 (x8)

☒ NA5246■ 42.5x54.5x6mm

HBS211®
(22-75001B)
M12x1.50x113mm (x10)

JC598■
JC477■

JN576
(50-026765-00)

JJ268

PA659 (x8)

☒ NJ448 30x44x7mm, NBR
☒ NJ324■ 34x48x7mm, ACM
☒ NJ325■ 90x110x9mm, MVQ

HBS211®
(22-75001B)
M12x1.50x113mm (x10)

JC598■
JC477■

JN576
(50-026765-00)

JJ268

PA659 (x8)

☒ NJ367■ 51x70x11mm, NBR
☒ NJ330■ 101.6x125x13mm, MVQ

HBS031®
(22-18008B)
M10x1.50x102mm (x10)

JM5184
(50-029871-00)
Light Blue

JH5061
(50-029586-00)

JJ268

HR5033■
(24-30715-70/0)

☒ NB958 (x2) 42x53x7mm, FPM
(50-319323-00)

☒ NB959■ 35x50x7mm, FPM
(50-306644-50)

☒ NB847■ 88x108x11mm, FPM
(50-307171-70)

HBS406
(22-75007B)

JM5296
B6ZE

JH5061
(50-029586-00)

JJ268

HC5009■

☒ NK158■ 37x50.5x7mm, ACM

JC781■

JN752
(50-028055-00)

JH5061
(50-029586-00)

JJ268

PA956 (x16)

☒ NJ324 (x2) 34x48x7mm, ACM
☒ NJ448■ 30x44x7mm, NBR
☒ NJ650■ 83x100x9mm, ACM







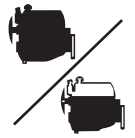



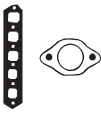

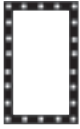











MAZDA



















KW/PS











Xedos 9 2.0L 24V		08/93 → 01/00		155	BX790 (MLS) ❏ BX780 (MLS) ❏		
KF	1995	6	78.00	Injection, DOHC	105- 106/ 143- 144		
Xedos 9 2.3L 24V		02/95 → 01/00		156	AG8160 (MLS) ❏ 06/96 → AG8150 (MLS) ❏ 06/96 →	CG8150	FG8150
KJ-ZEM	2255	6	80.30	L-Jetronic, DOHC	155/211		
Xedos 9 2.5L 24V		07/93 → 07/00		157	BV410 (MLS) ❏ BV420 (MLS) ❏	DV410	
KL	2497	6	84.50	L-Jetronic, DOHC, V6	120- 123/ 163- 167		
Xedos 9 2.5L V6		07/00 →					

								 BV410, BV420
		JD5756  JD5755 	JN832 JN833		PB313 (x12) PB314 (x12)	 NA5246  42.5x54.5x6mm		 BX780
		JD5755 	HM5269   06/96 → KJ HM5270   06/96 → KJ			 NA5246  42.5x54.5x6mm		 BX790
		JD5756  JD5755 				 NA5246  42.5x54.5x6mm		

		CC			9			CC			9
M 102.910	Petrol	1797	4	89.00	2	M 110.987	Petrol	2746	6	86.00	177
M 102.920	Petrol	1997	4	89.00	79	M 110.988	Petrol	2746	6	86.00	109
M 102.921	Petrol	1997	4	89.00	3	M 110.989	Petrol	2746	6	86.00	177
M 102.922	Petrol	1997	4	89.00	80	M 110.990	Petrol	2746	6	86.00	195
M 102.922	Petrol	1997	4	89.00	83	M 111.920	Petrol	1799	4	85.30	26
M 102.924	Petrol	1997	4	89.00	3	M 111.921	Petrol	1799	4	85.30	26
M 102.939	Petrol	1997	4	89.00	79	M 111.940	Petrol	1998	4	89.90	82
M 102.942	Petrol	2298	4	95.50	232	M 111.941	Petrol	1998	4	89.90	30
M 102.942	Petrol	2298	4	95.50	242	M 111.941	Petrol	1998	4	89.90	61
M 102.945	Petrol	2299	4	95.50	233	M 111.942	Petrol	1998	4	89.90	85
M 102.945	Petrol	2299	4	95.50	242	M 111.942	Petrol	1998	4	89.90	88
M 102.946	Petrol	2299	4	95.50	232	M 111.943	Petrol	1998	4	89.90	211
M 102.946	Petrol	2299	4	95.50	249	M 111.944	Petrol	1998	4	89.90	34
M 102.961	Petrol	1997	4	89.00	4	M 111.944	Petrol	1998	4	89.90	63
M 102.961	Petrol	1997	4	89.00	5	M 111.945	Petrol	1998	4	89.90	30
M 102.962	Petrol	1997	4	89.00	4	M 111.945	Petrol	1998	4	89.90	61
M 102.962	Petrol	1997	4	89.00	5	M 111.946	Petrol	1998	4	89.90	211
M 102.962	Petrol	1997	4	89.00	81	M 111.947	Petrol	1998	4	89.90	85
M 102.963	Petrol	1997	4	89.00	81	M 111.948	Petrol	1998	4	89.90	255
M 102.979	Petrol	2299	4	95.50	140	M 111.948	Petrol	1998	4	89.90	265
M 102.979	Petrol	2299	4	95.50	143	M 111.951	Petrol	1998	4	89.90	29
M 102.980	Petrol	2299	4	95.50	96	M 111.952	Petrol	1998	4	89.90	29
M 102.981	Petrol	2299	4	95.50	141	M 111.955	Petrol	1998	4	89.90	29
M 102.982	Petrol	2299	4	95.50	97	M 111.956	Petrol	1998	4	89.90	29
M 102.985	Petrol	2299	4	95.50	9	M 111.956	Petrol	1998	4	89.90	62
M 102.987	Petrol	2299	4	95.50	140	M 111.957	Petrol	1998	4	89.90	87
M 102.987	Petrol	2299	4	95.50	141	M 111.958	Petrol	1998	4	89.90	212
M 102.989	Petrol	2299	4	95.50	142	M 111.960	Petrol	2199	4	89.90	91
M 102.996	Petrol	2299	4	95.50	142	M 111.961	Petrol	2199	4	89.90	38
M 102.997	Petrol	2299	4	95.50	142	M 111.970	Petrol	2295	4	90.90	98
M 103.941	Petrol	2599	6	82.90	174	M 111.973	Petrol	2295	4	90.90	214
M 103.980	Petrol	2962	6	88.50	115	M 111.973	Petrol	2295	4	90.90	66
M 103.981 (KAT)	Petrol	2962	6	88.50	181	M 111.974	Petrol	2295	4	90.90	40
M 103.982	Petrol	2962	6	88.50	198	M 111.975	Petrol	2295	4	90.90	41
M 103.983	Petrol	2962	6	88.50	120	M 111.975	Petrol	2295	4	90.90	66
M 103.983	Petrol	2962	6	88.50	125	M 111.977	Petrol	2295	4	90.90	165
M 103.984	Petrol	2962	6	88.50	199	M 111.978	Petrol	2295	4	90.90	257
M 103.985	Petrol	2962	6	88.50	120	M 111.978	Petrol	2295	4	90.90	269
M 103.985	Petrol	2962	6	88.50	121	M 111.979	Petrol	2295	4	90.90	222
M 103.985	Petrol	2962	6	88.50	125	M 111.979	Petrol	2295	4	90.90	227
M 103.987	Petrol	2962	6	88.50	151	M 111.981	Petrol	2295	4	90.90	42
M 104.900	Petrol	3199	6	89.90	259	M 111.982	Petrol	2295	4	90.90	65
M 104.941	Petrol	2799	6	89.90	50	M 111.983	Petrol	2295	4	90.90	213
M 104.941 (AMG 3.6)	Petrol	3606	6	91.00	56	M 111.984	Petrol	2295	4	90.90	222
M 104.942	Petrol	2799	6	89.90	112	M 111.984	Petrol	2295	4	90.90	227
M 104.943	Petrol	2799	6	89.90	196	M 111.984	Gas	2295	4	90.90	222
M 104.944	Petrol	2799	6	89.90	178	M 111.984	Gas	2295	4	90.90	223
M 104.945	Petrol	2799	6	89.90	112	M 112.910	Petrol	2398	6	83.20	43
M 104.980	Petrol	2960	6	88.50	123	M 112.911	Petrol	2398	6	83.20	100
M 104.980	Petrol	2960	6	88.50	126	M 112.912	Petrol	2398	6	89.90	47
M 104.981	Petrol	2960	6	88.50	200	M 112.912	Petrol	2398	6	89.90	67
M 104.990	Petrol	3199	6	89.90	183	M 112.913	Petrol	2398	6	89.90	108
M 104.991	Petrol	3199	6	89.90	201	M 112.914	Petrol	2398	6	89.90	107
M 104.992	Petrol	3199	6	89.90	130	M 112.915	Petrol	2597	6	89.90	47
M 104.992	Petrol	3199	6	89.90	132	M 112.916	Petrol	2597	6	89.90	47
M 104.992 (AMG 3.6)	Petrol	3606	6	91.00	138	M 112.917	Petrol	2597	6	89.90	101
M 104.994	Petrol	3199	6	89.90	183	M 112.917	Petrol	2597	6	89.90	108
M 104.995	Petrol	3199	6	89.90	130	M 112.920	Petrol	2799	6	89.90	49
M 104.996	Petrol	3199	6	89.90	153	M 112.921	Petrol	2799	6	89.90	113
M 110.922	Petrol	2746	6	86.00	175	M 112.922	Petrol	2799	6	89.90	179
M 110.923	Petrol	2746	6	86.00	109	M 112.923	Petrol	2799	6	89.90	197
M 110.923	Petrol	2746	6	86.00	110	M 112.925	Petrol	2799	6	89.90	197
M 110.924	Petrol	2746	6	86.00	176	M 112.940	Petrol	3199	6	89.90	70
M 110.926	Petrol	2746	6	86.00	176	M 112.941	Petrol	3199	6	89.90	133
M 110.982	Petrol	2746	6	86.00	195	M 112.942	Petrol	3199	6	89.90	168
M 110.983	Petrol	2746	6	86.00	175	M 112.943	Petrol	3199	6	89.90	202
M 110.984	Petrol	2746	6	86.00	109	M 112.944	Petrol	3199	6	89.90	184
M 110.985	Petrol	2746	6	86.00	175	M 112.945	Petrol	3199	6	89.90	154
M 110.986	Petrol	2746	6	86.00	195	M 112.946	Petrol	3199	6	89.90	54

		CC			9			CC			9
M 112.947	Petrol	3199	6	89.90	215	M 272.960	Petrol	3498	6	92.90	71
M 112.949	Petrol	3199	6	89.90	133	M 272.962	Petrol	3498	6	92.90	169
M 112.949	Petrol	3199	6	89.90	134	M 272.963	Petrol	3498	6	92.90	216
M 112.951	Petrol	3199	6	89.90	263	M 272.964	Petrol	3498	6	92.90	136
M 112.951	Petrol	3199	6	89.90	270	M 272.964	Petrol	3498	6	92.90	137
M 112.951	Petrol	3199	6	89.90	271	M 272.964	Petrol	3498	6	92.90	74
M 112.953	Petrol	3199	6	89.90	54	M 272.965	Petrol	3498	6	92.90	188
M 112.954	Petrol	3199	6	89.90	133	M 272.967	Petrol	3498	6	92.90	169
M 112.955	Petrol	3199	6	89.90	70	M 272.970	Petrol	3498	6	92.90	55
M 112.960	Petrol	3199	6	89.90	215	M 272.972	Petrol	3498	6	92.90	136
M 112.961	Petrol	3199	6	89.90	54	M 272.972	Petrol	3498	6	92.90	137
M 112.970	Petrol	3724	6	97.00	170	M 272.985	Petrol	3498	6	92.90	75
M 112.972	Petrol	3724	6	97.00	189	M 273.923	Petrol	4663	8	92.90	158
M 112.973	Petrol	3724	6	97.00	203	M 273.923	Petrol	4663	8	92.90	193
M 112.975	Petrol	3724	6	97.00	189	M 273.961	Petrol	5461	8	97.20	194
M 112.976	Petrol	3724	6	97.00	264	M 273.963	Petrol	5461	8	98.00	161
M 112.976	Petrol	3724	6	97.00	272	M 273.963	Petrol	5461	8	98.00	173
M 113.941	Petrol	4266	8	89.90	192	M 273.965	Petrol	5461	8	98.00	207
M 113.948	Petrol	4266	8	89.90	192	M 273.965	Petrol	5461	8	98.00	72
M 113.961	Petrol	4966	8	97.00	205	OM 601.911	Diesel	1978	4	87.00	7
M 113.962	Petrol	4966	8	97.00	159	OM 601.911	Diesel	1978	4	87.00	8
M 113.963	Petrol	4966	8	97.00	205	OM 601.912	Diesel	1978	4	87.00	78
M 113.982	Petrol	5439	8	97.00	162	OM 601.912	Diesel	1978	4	87.00	84
M 113.985	Petrol	5439	8	97.00	208	OM 601.913	Diesel	1997	4	87.00	33
M 113.989	Petrol	5439	8	97.00	217	OM 601.915	Diesel	1997	4	87.00	31
M 113.992	Petrol	5439	8	97.00	206	OM 601.940	Diesel	2299	4	89.00	231
M 113.992	Petrol	5439	8	97.00	208	OM 601.940	Diesel	2299	4	89.00	240
M 113.993	Petrol	5439	8	97.00	160	OM 601.940	Diesel	2299	4	89.00	241
M 116.962	Petrol	3818	8	92.00	204	OM 601.941	Diesel	2299	4	89.00	248
M 116.963	Petrol	3818	8	92.00	190	OM 601.942	Diesel	2299	4	89.00	268
M 119.971	Petrol	4196	8	92.00	191	OM 601.943	Diesel	2299	4	89.00	220
M 119.975	Petrol	4196	8	92.00	139	OM 601.943	Diesel	2299	4	89.00	225
M 119.981	Petrol	4196	8	92.00	191	OM 601A.970	Diesel	2299	4	89.00	258
M 120.981	Petrol	5987	12	89.00	209	OM 601A.970	Diesel	2299	4	89.00	268
M 120.981	Petrol	5987	8	89.00	209	OM 602.911	Diesel	2497	5	87.00	10
M 120.983	Petrol	5987	12	89.00	209	OM 602.911	Diesel	2497	5	87.00	103
M 123.921	Petrol	2527	6	86.00	104	OM 602.912	Diesel	2497	5	87.00	102
M 166.940	Petrol	1397	4	80.00	11	OM 602.912	Diesel	2497	5	87.00	103
M 166.960	Petrol	1598	4	80.00	13	OM 602.930	Diesel	2497	5	87.00	103
M 166.961	Petrol	1598	4	80.00	251	OM 602.930	Diesel	2497	5	87.00	145
M 166.990	Petrol	1898	4	80.00	16	OM 602.931	Diesel	2497	5	87.00	103
M 166.991	Petrol	1898	4	84.00	253	OM 602.931	Diesel	2497	5	87.00	145
M 166.995	Petrol	2084	4	84.00	20	OM 602.939	Diesel	2497	5	87.00	103
M 266.920	Petrol	1498	4	83.00	12	OM 602.939	Diesel	2497	5	87.00	145
M 266.920	Petrol	1498	4	83.00	21	OM 602.940	Diesel	2874	5	89.00	171
M 266.940	Petrol	1699	4	83.00	15	OM 602.940	Diesel	2874	5	89.00	236
M 266.940	Petrol	1699	4	83.00	22	OM 602.940	Diesel	2874	5	89.00	238
M 266.960	Petrol	2034	4	83.00	18	OM 602.940	Diesel	2874	5	89.00	245
M 266.960	Petrol	2034	4	83.00	24	OM 602.942	Diesel	2874	5	89.00	147
M 266.980	Petrol	2034	4	83.00	19	OM 602.961	Diesel	2497	5	87.00	10
M 266.980	Petrol	2034	4	83.00	25	OM 602.961	Diesel	2497	5	87.00	103
M 271.921	Petrol	1796	4	82.00	27	OM 602.980	Diesel	2874	5	89.00	230
M 271.940	Petrol	1796	4	82.50	27	OM 602.982	Diesel	2874	5	89.00	116
M 271.940	Petrol	1796	4	82.50	59	OM 602.983	Diesel	2874	5	89.00	147
M 271.941	Petrol	1796	4	82.00	76	OM 602.984	Diesel	2874	5	89.00	254
M 271.941	Bi-Fuel	1796	4	82.00	76	OM 602.985	Diesel	2874	5	89.00	254
M 271.942	Petrol	1796	4	82.00	28	OM 602A.962	Diesel	2497	5	87.00	102
M 271.942	Petrol	1796	4	82.00	58	OM 602A.962	Diesel	2497	5	87.00	103
M 271.944	Petrol	1795	4	82.00	210	OM 603.912	Diesel	2996	6	87.00	119
M 271.946	Petrol	1796	4	82.00	27	OM 603.912	Diesel	2996	6	87.00	124
M 271.946	Petrol	1796	4	82.00	57	OM 603.912	Diesel	2996	6	87.00	149
M 271.946	Petrol	1796	4	82.00	76	OM 603.913	Diesel	2996	6	87.00	119
M 271.948	Petrol	1796	4	82.00	27	OM 603.931	Diesel	2996	6	87.00	149
M 271.950	Petrol	1796	4	82.00	27	OM 603.960	Diesel	2996	6	87.00	122
M 271.952	Petrol	1796	4	82.00	27	OM 603.960	Diesel	2996	6	87.00	124
M 271.955	Petrol	1796	4		60	OM 603.963	Diesel	2996	6	87.00	119
M 272.920	Petrol	2496	6	88.00	44	OM 603.963	Diesel	2996	6	87.00	122
M 272.940	Petrol	2996	6	88.00	52	OM 603.963	Diesel	2996	6	87.00	124
M 272.960	Petrol	3498	6	92.90	55	OM 603.963	Diesel	2996	6	87.00	128

		CC			9			CC			9
OM 603.971	Diesel	3449	6	89.00	187	OM 640.941	Diesel	1991	4	83.00	23
OM 603.972	Diesel	3449	6	89.00	155	OM 640.942	Diesel	1991	4	83.00	17
OM 604.910	Diesel	2155	4	89.00	39	OM 642.822	Diesel	2987	6	83.00	148
OM 604.912	Diesel	2155	4	89.00	95	OM 642.910	Diesel	2987	6	83.00	118
OM 604.915	Diesel	2155	4	87.00	32	OM 642.910	Diesel	2987	6	83.00	51
OM 604.917	Diesel	2155	4	87.00	86	OM 642.910	Diesel	2987	6	83.00	69
OM 605.910	Diesel	2497	5	87.00	45	OM 642.910	Diesel	2987	6	83.00	73
OM 605.911	Diesel	2497	5	87.00	105	OM 642.920	Diesel	2987	6	83.00	117
OM 605.912	Diesel	2497	5	87.00	105	OM 642.921	Diesel	2987	6	83.00	117
OM 605.960	Diesel	2497	5	87.00	46	OM 642.930	Diesel	2987	6	83.00	180
OM 605.962	Diesel	2497	5	87.00	106	OM 642.940	Diesel	2987	6	83.00	167
OM 606.910	Diesel	2996	6	87.00	127	OM 642.950	Diesel	2987	6	83.00	172
OM 606.912	Diesel	2996	6	87.00	127	OM 642.960	Diesel	2987	6	83.00	51
OM 606.961	Diesel	2996	6	87.00	182	OM 642.961	Diesel	2987	6	83.00	163
OM 606.962	Diesel	2996	6	87.00	129	OM 642.961	Diesel	2987	6	83.00	51
OM 606.964	Diesel	2996	6	87.00	152	OM 642.970	Diesel	2987	6	83.00	148
OM 611.960	Diesel	2151	4	88.00	36	OM 646.820	Diesel	2148	4	88.00	90
OM 611.961	Diesel	2148	4	88.00	92	OM 646.821	Diesel	2148	4	88.00	90
OM 611.961	Diesel	2148	4	88.00	94	OM 646.951	Diesel	2148	4	88.00	93
OM 611.962	Diesel	2148	4	88.00	35	OM 646.961	Diesel	2148	4	88.00	89
OM 611.962	Diesel	2148	4	88.00	37	OM 646.962	Diesel	2148	4	88.00	35
OM 611.980	Diesel	2151	4	88.00	256	OM 646.962	Diesel	2148	4	88.00	37
OM 611.980	Diesel	2151	4	88.00	266	OM 646.963	Diesel	2148	4	88.00	37
OM 611.981	Diesel	2148	4	88.00	218	OM 646.966	Diesel	2148	4	88.00	64
OM 611.981	Diesel	2148	4	88.00	219	OM 646.982	Diesel	2148	4	88.00	260
OM 611.987	Diesel	2148	4	88.00	218	OM 646.982	Diesel	2148	4	88.00	261
OM 611A (60 KW CDI)	Diesel	2148	4	88.00	266	OM 646.982	Diesel	2148	4	88.00	262
OM 611LA (75 KW CDI)	Diesel	2148	4	88.00	266	OM 646.982	Diesel	2148	4	88.00	267
OM 612.961	Diesel	2688	5	88.00	111	OM 646.983	Diesel	2148	4	88.00	267
OM 612.962	Diesel	2685	5	88.00	48	OM 647.961	Diesel	2685	5	88.00	111
OM 612.962	Diesel	2685	5	88.00	68	OM 648.960	Diesel	3222	6	88.00	186
OM 612.963	Diesel	2685	5	88.00	166	OM 648.961	Diesel	3222	6	88.00	131
OM 612.966	Diesel	2685	5	88.00	146	OM 668.914	Diesel	1689	4	80.00	252
OM 612.967	Diesel	2685	5	88.00	68	OM 668.940	Diesel	1689	4	80.00	14
OM 612.981	Diesel	2685	5	88.00	228	OM 668.941	Diesel	1689	4	80.00	14
OM 612.981	Diesel	2685	5	88.00	229	OM 668.942	Diesel	1689	4	80.00	14
OM 612.990	Diesel	2950	5	88.00	53						
OM 613.960	Diesel	3222	6	88.00	185						
OM 613.961	Diesel	3226	6	88.00	135						
OM 615.917	Diesel	2197	4	87.00	164						
OM 615.937	Diesel	2197	4	87.00	164						
OM 615.939	Diesel	2197	4	87.00	164						
OM 615.940	Diesel	1988	4	87.00	77						
OM 616	Diesel	2399	4	91.00	1						
OM 616.910	Diesel	2400	4	91.00	247						
OM 616.912	Diesel	2399	4	91.00	99						
OM 616.913	Diesel	2398	4	91.00	243						
OM 616.913	Diesel	2398	4	91.00	244						
OM 616.914	Diesel	2399	4	90.90	250						
OM 616.917	Diesel	2399	4	90.90	234						
OM 616.934	Diesel	2399	4	90.90	234						
OM 616.936	Diesel	2399	4	90.90	144						
OM 616.937	Diesel	2399	4	90.90	234						
OM 616.937	Diesel	2399	4	90.90	235						
OM 616.939	Diesel	2399	4	90.90	234						
OM 616.939	Diesel	2399	4	90.90	235						
OM 616.939	Diesel	2399	4	90.90	243						
OM 616.939	Diesel	2399	4	90.90	244						
OM 616.963	Diesel	2399	4	90.90	1						
OM 617.912	Diesel	3005	5	91.00	114						
OM 617.913	Diesel	2998	5	87.00	237						
OM 617.913	Diesel	2998	5	87.00	239						
OM 617.913	Diesel	2998	5	87.00	246						
OM 617.931	Diesel	3005	5	90.90	150						
OM 617.952	Diesel	3005	5	91.00	114						
OM 628.962	Diesel	3996	8	86.00	157						
OM 640.940	Diesel	1991	4	83.00	17						
OM 640.940	Diesel	1991	4	83.00	23						
OM 640.941	Diesel	1991	4	83.00	17						











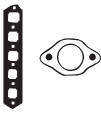

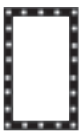

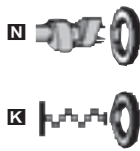

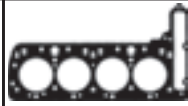



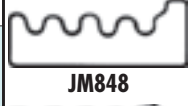

MERCEDES-BENZ

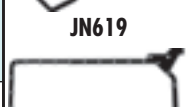
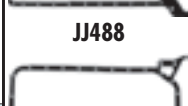

KW/PS

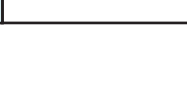

100 2.4L D (631) Diesel		02/88 → 02/96		1		BC790 (Fibre)	DC790■
OM 616.963	2399	4	90.90	SOHC	53-56/ 72-76	30-024065-10	21-24065-24/0
OM 616	2399	4	91.00		41-55/ 56-75		
190 E 1.8L (W201)		04/90 → 08/93		2		BH870 (Fibre)	DH873 [195] 21-26004-55/0 DH876 [196] 21-26004-20/0
M 102.910	1797	4	89.00		77/80/ 105/ 109	30-026004-10	EH872 22-26812-04/0
190 E 2.0L (W201)		10/82 → 05/90		3		BH870 (Fibre)	DH870■ [195] (21-26004-56/0)
M 102.924	1997	4	89.00	Injection	62/93/ 84/126	30-026004-10	EH872 22-26812-04/0
M 102.921	1997	4	89.00		66/77/ 90/105		
190 E 2.0L (W201)		01/85 → 08/93		4		BH870 (Fibre)	DH873 [195] 21-26004-55/0 DH876 [196] 21-26004-20/0
M 102.961/M 102.962	1997	4	89.00	Injection	62/93/ 84/126	30-026004-10	EH872 22-26812-04/0
190 E 2.0L (W201)		10/82 → 06/93		5		BH870 (Fibre)	DH873 [195] 21-26004-55/0 DH876 [196] 21-26004-20/0
M 102.961/M 102.962	1997	4	89.00	Injection	62/93/ 84/126	30-026004-10	EH872 22-26812-04/0 08/86 →
190 E 2.0L (W201)		10/82 → 06/93		6		BH870 (Fibre)	DH873 [195] 21-26004-55/0 DH876 [196] 21-26004-20/0
	1996	4			93/126	30-026004-10	EH872 22-26812-04/0 08/86 →
190 E 2.0L D (W201) Diesel		08/83 → 08/89		7		BT540 (Fibre) [198]	DT540☒ 21-27106-51/0 DT541
OM 601.911	1978	4	87.00		53-55/ 72	30-027106-20 Eng.003 361 → Eng.028 240 →	EM720 22-24895-01/0
190 E 2.0L D (W201) Diesel		08/89 → 08/93		8		BT540 (Fibre)	DT540☒ 21-27106-51/0 DT541
OM 601.911	1978	4	87.00		53-55/ 72	30-027106-20	EM720 22-24895-01/0
190 E 2.3L (W201)		09/86 → 08/93		9		BH880 (Fibre)	DH882☒ [195] 21-26005-54/0
M 102.985	2299	4	95.50	K-Jetronic	92/100/ 125/ 136	30-026005-10	EH872 22-26812-04/0

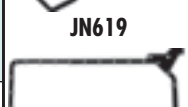
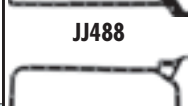
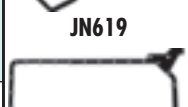
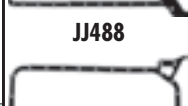
								
HBS045 Ⓞ (22-26067B) M12x1.75x105mm (x4) M12x1.75x145mm (x6) M12x1.75x120mm (x8)	JB162 (31-024970-20)	JM848 50-022825-00				NB975 45x74.5x12mm, FPM (50-306557-50) PA815 78x94x8mm (31-019993-30)		 BC790  BH870, BH880  BT540  JD158  JD159  JD182  JD291  JD292  JD293  JE5026  JM848  JN454  JN572  JN607  JN619  JJ488  JJ498
HBS047 Ⓞ (22-26065B) M12x1.75x120mm (x10)	JD182 31-026877-00 JD292 (x3) 31-026634-10 JD293 31-026635-10	JN454 [195] 50-024959-10 JN607 [196] 50-025120-10	JJ488 (31-026812-00)	HR756 24-30615-70/0		NB973 45x67x8mm, FPM (50-305910-50) NB974 93x114x13mm, FPM (50-319192-00)		
HBS047 Ⓞ (22-26065B) M12x1.75x120mm (x10)	JD291 31-025684-10 JD292 (x3) 31-026634-10 JD293 31-026635-10 JE5026 (31-024888-10)	JN454 [195] 50-024959-10 JN607 [196] 50-025120-10	JJ488 (31-026812-00)	HR756 24-30615-70/0		NB973 45x67x8mm, FPM (50-305910-50) NB974 93x114x13mm, FPM (50-319192-00)		
HBS047 Ⓞ (22-26065B) M12x1.75x120mm (x10)	JD182 31-026877-00 JD292 (x3) 31-026634-10 JD293 31-026635-10 JE5026 (31-024888-10)	JN454 [195] 50-024959-10 JN607 [196] 50-025120-10	JJ488 (31-026812-00)	HR756 24-30615-70/0		NB973 45x67x8mm, FPM (50-305910-50) NB974 93x114x13mm, FPM (50-319192-00)		
HBS047 Ⓞ (22-26065B) M12x1.75x120mm (x10)	JD182 31-026877-00 JD292 (x3) 31-026634-10 JD293 31-026635-10 JE5026 (31-024888-10)	JN454 [195] 50-024959-10 JN607 [196] 50-025120-10	JJ488 (31-026812-00)	HR756 24-30615-70/0		NB973 45x67x8mm, FPM (50-305910-50) NB974 93x114x13mm, FPM (50-319192-00)		
HBS047 Ⓞ (22-26065B) M12x1.75x120mm (x10)	JD292 (x3) 31-026634-10 JD293 31-026635-10 JE5026 (31-024888-10)	JN454 [195] 50-024959-10 JN607 [196] 50-025120-10	JJ488 (31-026812-00)	HR756 24-30615-70/0		NB973 45x67x8mm, FPM (50-305910-50) NB974 93x114x13mm, FPM (50-319192-00)		
HBS058 Ⓞ (22-26069B) M10x1.50x80mm (x4) M10x1.50x115mm (x5) M10x1.50x102mm (x9)	JD158 31-024911-00 JD159	JN572 [196] 50-026030-00 JN619 [195] 50-026031-00	JJ498 (31-026923-00)	HR757 24-30672-71/0		NB973 45x67x8mm, FPM (50-305910-50) NB974 93x114x13mm, FPM (50-319192-00)	KK5683 [160]	 JN619  JJ488  JJ498
HBS058 Ⓞ (22-26069B) M10x1.50x80mm (x4) M10x1.50x115mm (x5) M10x1.50x102mm (x9)	JD158 31-024911-00 JD159	JN572 [196] 50-026030-00 JN619 [195] 50-026031-00	JJ498 (31-026923-00)	HR757 24-30672-71/0		NB973 45x67x8mm, FPM (50-305910-50) NB974 93x114x13mm, FPM (50-319192-00)	KK5683 [160]	 JJ488  JJ498
HBS047 Ⓞ (22-26065B) M12x1.75x120mm (x10)	JD182 31-026877-00 JD292 (x3) 31-026634-10 JD293 31-026635-10	JN454 [195] 50-024959-10 JN607 [196] 50-025120-10	JJ488 (31-026812-00)	HR756 24-30615-70/0		NB973 45x67x8mm, FPM (50-305910-50) NB974 93x114x13mm, FPM (50-319192-00)		











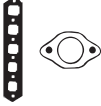

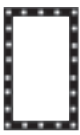







MERCEDES-BENZ



KW/PS



190 E 2.0 D (W201) Diesel		04/85 → 08/93		10		BN720 (Fibre), 1.74mm 30-027216-20	DN722 [195] 21-27216-51/0 DN723 [196]	EN720 22-26946-01/0
190 E 2.5L TD (W201) Diesel		02/88 → 08/93						
OM 602.911	2497	5	87.00		66-69/ 90-94			
OM 602.961	2497	5	87.00		90-93/ 122- 126			
A-Class A 140 (W168)		07/97 → 08/04		11		AB5550 (MLS) 30-029326-00	CB5550 21-29326-20/0	EB5550 22-29326-00/0
M 166.940	1397	4	80.00	SOHC	60/81			
A-Class A 150 (W169)		09/04 →		12		AG8500 (Steel Elastomer) 30-030199-00	CG8500 21-30199-00/0	
M 266.920	1498	4	83.00	Injection	70/95			
A-Class A 140 (W168)		01/01 → 08/04		13		AB5550 (MLS) 30-029326-00	CB5550 21-29326-20/0	EB5550 22-29326-00/0
A-Class A 160 (W168)		07/97 → 08/04						
M 166.960	1598	4	80.00	SOHC	75/102			
A-Class A 160 CDI (W168) Diesel		07/98 → 08/04		14		AB5560 (MLS), 1.20mm 30-029329-00	CB5560 21-29329-20/0	EB5560 22-29329-00/0
A-Class A 170 CDI (W168) Diesel		07/98 → 08/04						
OM 668.941	1689	4	80.00		44/55/ 60/75			
OM 668.940/OM 668.942	1689	4	80.00		60-70/ 82-95			
A-Class A 170 (W169)		09/04 →		15		AG8500 (Steel Elastomer) 30-030199-00	CG8500 21-30199-00/0	
M 266.940	1699	4	83.00	Injection	85/116			
A-Class A 190 (W168)		03/99 → 08/04		16		AB5570 (MLS), 0.70mm 30-030362-00	CB5570 (21-29330-20/0)	EB5550 22-29326-00/0
M 166.990	1898	4	80.00		92/125			
A-Class A 160 CDI (W169) Diesel		09/04 →		17		AG8501 (MLS) 30-030200-00	CG8501 21-30200-00/0	
A-Class A 180 CDI (W169) Diesel		09/04 →						
A-Class A 200 CDI (W169) Diesel		09/04 →						
OM 640.942	1991	4	83.00	Direct Injection, DOHC	60/81			
OM 640.940	1991	4	83.00	Direct Injection	80/109			
OM 640.941	1991	4	83.00	Direct Injection, DOHC	103/140			
A-Class A 200 (W169)		09/04 →		18		AH5000 (MLS) 30-030362-00		
M 266.960	2034	4	83.00	Injection	100/136			
A-Class A 200 (W169)		09/05 →		19		AH5000 (MLS) 30-030362-00		
M 266.980	2034	4	83.00	Injection	142/193			
A-Class A 210 (W168)		03/02 → 08/04		20		AB5570 (MLS), 0.70mm 30-030362-00		
M 166.995	2084	4	84.00	Injection, SOHC	103/140			
B-Class B 150 (W245)		03/05 →		21		AG8500 (Steel Elastomer) 30-030199-00	CG8500 21-30199-00/0	
M 266.920	1498	4	83.00	Injection	70/95			
B-Class B 170 (W245)		03/05 →		22		AG8500 (Steel Elastomer) 30-030199-00	CG8500 21-30199-00/0	
M 266.940	1699	4	83.00	Injection	85/116			

								
HBS059 ® (22-26006B) M10x1.50x80mm (x5) M10x1.50x115mm (x6) M10x1.50x102mm (x11)	JD298 ■ 31-025171-30 JD299 ■ 31-025172-00	JN621 [195] 50-026033-00 JN622 [196] 50-026032-00	JJ543 (31-026946-00)	HR758 ■ 24-30637-45/0	NA971 ■ 45x67x10mm, FPM (50-305913-50) NA974 ■ 93x114x13mm, FPM (50-319192-00)			 AB5550  AB5560  AB5570  BN720  JD298  JD299  JD5135  JD5136  JM5163  JM5164  JM5165  JN621  JN622  JJ543
	JD5804 ■ (x4) 50-030212-00 JD5135 ■ [274] (31-029327-00)	JM5163 (50-029666-00)		HR5097 ■ 24-30614-74/0	NA5107 [3] 90x167x10.5mm, PTFE (50-319405-00) NA5109 ■ 40x62x8mm, PTFE (50-319404-00)			
HBS457 (22-26023B) M10x1.50x180mm (x10)	JD5799 ■ (x4) 50-030204-00 JD5802 ■ 31-030210-00	HR397 [57] 34-000410-00	HR397 [57] 34-000410-00	HR5097 ■ 24-30614-74/0	NA5109 40x62x8mm, PTFE (50-319404-00)			
	JD5804 ■ (x4) 50-030212-00 JD5135 ■ [274] (31-029327-00)	JM5163 (50-029666-00)		HR5097 ■ 24-30614-74/0	NA5107 [3] 90x167x10.5mm, PTFE (50-319405-00) NA5109 ■ 40x62x8mm, PTFE (50-319404-00)			
HBS291 ® (22-26012B) M12x1.75x185mm (x10)	JD5834 ■ (x2) 50-030178-00 JD5136 ■ (31-029328-00)	JM5165 ■ (50-029668-00) JM5164 ■ (50-029667-00)	HR397 [57] 34-000410-00	HR5056 ■ 24-30704-41/0	NA5109 ■ 40x62x8mm, PTFE (50-319404-00) NA5107 [3] 90x167x10.5mm, PTFE (50-319405-00)			
HBS457 (22-26023B) M10x1.50x180mm (x10)	JD5799 ■ (x4) 50-030204-00 JD5802 ■ 31-030210-00	HR397 [57] 34-000410-00	HR397 [57] 34-000410-00	HR5097 ■ 24-30614-74/0	NA5109 ■ 40x62x8mm, PTFE (50-319404-00)			
	JD5135 ■ [274] (31-029327-00)	JM5163 (50-029666-00)	HR397 [57] 34-000410-00	HR5097 ■ 24-30614-74/0	NA5109 ■ 40x62x8mm, PTFE (50-319404-00) NA5107 [3] 90x167x10.5mm, PTFE (50-319405-00)			
HBS458 (22-26024B) M12x1.75x115mm (x10)	JD5800 ■ 31-030208-00 JD5803 ■ 31-030211-00	JM7027 50-030202-00		HR791 ■ 24-30614-76/0	NA5109 ■ 40x62x8mm, PTFE (50-319404-00)			
HBS457 (22-26023B) M10x1.50x180mm (x10)	JD5799 ■ (x4) 50-030204-00 JD5802 ■ 31-030210-00	HR397 [57] 34-000410-00	HR397 [57] 34-000410-00	HR5097 ■ 24-30614-74/0	NA5109 ■ 40x62x8mm, PTFE (50-319404-00)			
HBS457 (22-26023B) M10x1.50x180mm (x10)	JD5799 ■ (x4) 50-030204-00	HR397 [57] 34-000410-00	HR397 [57] 34-000410-00	HR5097 ■ 24-30614-74/0	NA5109 ■ 40x62x8mm, PTFE (50-319404-00)			
HBS457 (22-26023B) M10x1.50x180mm (x10)		JM5163 (50-029666-00)		HR5097 ■ 24-30614-74/0	NA5109 ■ 40x62x8mm, PTFE (50-319404-00) NA5107 [3] 90x167x10.5mm, PTFE (50-319405-00)			
HBS457 (22-26023B) M10x1.50x180mm (x10)	JD5799 ■ (x4) 50-030204-00 JD5802 ■ 31-030210-00	HR397 [57] 34-000410-00	HR397 [57] 34-000410-00	HR5097 ■ 24-30614-74/0	NA5109 ■ 40x62x8mm, PTFE (50-319404-00)			
HBS457 (22-26023B) M10x1.50x180mm (x10)	JD5799 ■ (x4) 50-030204-00 JD5802 ■ 31-030210-00	HR397 [57] 34-000410-00	HR397 [57] 34-000410-00	HR5097 ■ 24-30614-74/0	NA5109 ■ 40x62x8mm, PTFE (50-319404-00)			











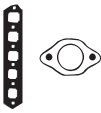

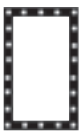

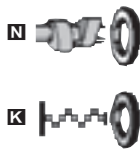

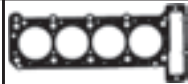





















MERCEDES-BENZ



KW/PS



B-Class B 180 CDI (W245) Diesel 03/05 → 23						AG8501 (MLS)	CG8501	
B-Class B 200 CDI (W245) Diesel 03/05 →						30-030200-00	21-30200-00/0	
OM 640.940	1991	4	83.00	Direct Injection	80/109			
OM 640.941	1991	4	83.00	Direct Injection, DOHC	103/140			
B-Class B 200 (W245) 03/05 → 24						AH5000 (MLS)		
M 266.960	2034	4	83.00	Injection	100/136	30-030362-00		
B-Class B 200 (W245) 03/05 → 25						AH5000 (MLS)		
M 266.980	2034	4	83.00	Injection	142/193	30-030362-00		
C-Class C 180 (W202) 03/93 → 05/00 26						BZ850 (Fibre)	DV820	EV810
C-Class C 180 T (S202) 06/96 → 09/00						30-027472-00	21-27472-50/0	22-27311-50/0
M 111.920/M 111.921	1799	4	85.30		90/122			
C-Class C 180 Kompressor (S203) 05/02 → 27						AG8790 (MLS)	CG8790	
C-Class C 180 Kompressor (S204) 08/07 →						(30-030197-00)	21-30197-00/0	
C-Class C 180 Kompressor (W203) 05/02 →								
C-Class C 180 Kompressor (W204) 01/07 →								
C-Class C 200 Kompressor (S203) 05/02 →								
C-Class C 200 Kompressor (S204) 08/07 →								
C-Class C 200 Kompressor (W203) 05/02 →								
C-Class C 200 Kompressor (W204) 01/07 →								
C-Class C 230 Kompressor (S203) 02/04 →								
C-Class C 230 Kompressor (W203) 02/04 →								
C-Class Coupe C 160 Kompressor (CL203) 05/02 →								
C-Class Coupe C 180 Kompressor (CL203) 05/02 →								
C-Class Coupe C 200 Kompressor (CL203) 05/02 →								
C-Class Coupe C 230 Kompressor (CL203) 05/02 →								
M 271.921	1796	4	82.00	Injection	90/122			
M 271.946	1796	4	82.00	Injection	105-125/143-170			
M 271.948	1796	4	82.00	Injection, DOHC	141/192			
M 271.950/M 271.952	1796	4	82.00	Injection, DOHC				
M 271.940	1796	4	82.50	Injection	120/163			
C-Class C 200 CGI Kompressor (CL203) 07/03 → 28						AG8790 (MLS)		
C-Class C 200 CGI Kompressor (S203) 07/03 →						(30-030197-00)		
C-Class C 200 CGI Kompressor (W203) 07/03 →								
M 271.942	1796	4	82.00	Injection	125/170			

								 BZ850
HBS458 (22-26024B) M12x1.75x115mm (x10)	JD5800  31-030208-00 JD5803  31-030211-00	JM7027 50-030202-00	HR397 [57] 34-000410-00		NA5109  40x62x8mm, PTFE (50-319404-00)			 JD160  JD161
HBS457 (22-26023B) M10x1.50x180mm (x10)	JD5799  (x4) 50-030204-00 JD5802  31-030210-00	HR397 [57] 34-000410-00	HR397 [57] 34-000410-00	HR5097  24-30614-74/0	NA5109  40x62x8mm, PTFE (50-319404-00)			 JD5226
HBS457 (22-26023B) M10x1.50x180mm (x10)	JD5799  (x4) 50-030204-00			HR5097  24-30614-74/0				 JN911
HBS150  (22-26009B) M12x1.75x102mm (x10)	JD160  (31-027310-00) JD5226  (x2) (50-028038-00) JD161  31-027309-10	JN911 50-027307-00 HM5057  24-27307-50/0	JJ499 (31-027311-00)	HR5085  (x4)	NB973  45x67x8mm, FPM (50-305910-50) NB974  93x114x13mm, FPM (50-319192-00)	JM5111 (x4) [119]		 JJ499
HBS459 (22-26021B) M10x1.50x165.0mm (x10)	JD5835  (x4) 50-030167-00 (FPM) JD5801  31-030209-00	JM7026 50-030201-00	HR397 [57] 34-000410-00 KG664 (33-110870-00)	HR5085  (x4)	NA5131  45x67x8mm, PTFE (50-319436-00)	NA5248 [2] 		
HBS459 (22-26021B) M10x1.50x165.0mm (x10)	JD5801  31-030209-00	JM7026 50-030201-00	HR397 [57] 34-000410-00	HR5085  (x4)	NA5131  45x67x8mm, PTFE (50-319436-00)	NA5248 [2] 		











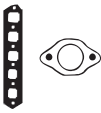

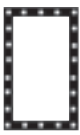

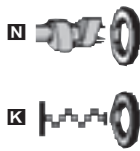





MERCEDES-BENZ



KW/PS

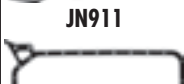
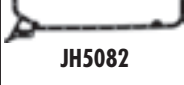

C-Class C 180 (S203) 03/01 → 05/02 29						BZ880 (Fibre) 30-027462-10	DZ881 ■ □ ○ 21-27462-52/0	
C-Class C 180 (W203) 10/00 → 05/02								
C-Class C 180 T (S202) 09/00 → 03/01								
C-Class C 200 Kompressor (S203) 03/01 → 05/02								
C-Class C 200 Kompressor (W203) 05/00 → 05/02								
C-Class C 200 T Kompressor (S202) 09/00 → 03/01								
C-Class Coupe C 180 (CL203) 03/01 → 05/02								
C-Class Coupe C 200 Kompressor (CL203) 03/01 → 05/02								
M 111.951/M 111.952	1998	4	89.90		95/129			
M 111.955/M 111.956	1998	4	89.90		120/163			
C-Class C 200 (W202) 01/94 → 05/00 30						BZ880 (Fibre) 30-027462-10	DV810 ■ □ ○ 21-27462-50/0 M111.941 DZ881 ■ □ ○ 21-27462-52/0 M111.945	EV810 22-27311-50/0
C-Class C 200 T (S202) 06/96 → 03/01								
M 111.941	1998	4	89.90	Injection, DOHC	100/136			
M 111.945	1998	4	89.90		100/136			
C-Class C 200 D Diesel 03/93 → 05/00 31						BT540 (Fibre) 30-027106-20	DT540 □ 21-27106-51/0 DT541	EM720 22-24895-01/0
OM 601.915 1997 4 87.00 Direct Injection, SOHC 55/75								
C-Class C 200 D (W202) Diesel 10/96 → 05/00 32								
C-Class C 200 T D (S202) Diesel 10/96 → 03/01								
OM 604.915	2155	4	87.00		65/88			
C-Class C 200 D (W202) Diesel 03/93 → 05/00 33						BT540 (Fibre) 30-027106-20	DT540 □ 21-27106-51/0 DT541	EM720 22-24895-01/0
OM 601.913 1997 4 87.00 55/75								
C-Class C 200 Kompressor (W202) 10/95 → 05/00 34						BZ880 (Fibre) 30-027462-10	DV810 ■ □ ○ 21-27462-50/0 → Eng. 0-003440 → Eng. 2-000017 DZ881 ■ □ ○ 21-27462-52/0 Eng. 0-003441 → Eng. 2-000018 →	EV810 22-27311-50/0
C-Class C 200 T Kompressor (S202) 11/96 → 03/01								
M 111.944	1998	4	89.90	Motronic, DOHC	132- 141/ 180- 192			
C-Class C 200 CDI (S203) Diesel 03/01 → 35						AC5620 (MLS), 1.20mm 30-029263-00	CC5620 (21-29263-30/0)	EC5620 22-29263-00/0
C-Class C 200 CDI (W203) Diesel 09/00 →								
OM 646.962	2148	4	88.00	Direct Injection, DOHC	75-90/ 102- 122			
OM 611.962	2148	4	88.00	Direct Injection, DOHC	85-105/ 116- 143			

								
HBS150 ⊗ (22-26009B) M12x1.75x102mm (x10)			HM5057 ■ 24-27307-50/0	JH5082 (31-029265-00)	HR5085 ■ (x4)	NB973 ■ 45x67x8mm, FPM (50-305910-50) NB974 ■ 93x114x13mm, FPM (50-319192-00)	NA5248 [2]■	 AC5620  BT540  BZ880  JD158  JD159  JD160  JD161  JD475  JD5225  JD5226  JD5378  JD5380  JM5157  JN572  JN619  JN911  JH5082
HBS150 ⊗ (22-26009B) M12x1.75x102mm (x10)	JD160 ■ (31-027310-00) M111.941 JD5226 ■ (x2) (50-028038-00) M111.945 JD161 ■ 31-027309-10	JN911 50-027307-00 HM5057 ■ 24-27307-50/0	JJ499 (31-027311-00)	HR5085 ■ (x4)	NB973 ■ 45x67x8mm, FPM (50-305910-50) NB974 ■ 93x114x13mm, FPM (50-319192-00)	JM5111 (x4) [119]		
HBS058 ⊗ (22-26069B) M10x1.50x80mm (x4) M10x1.50x115mm (x5) M10x1.50x102mm (x9)	JD158 ■ JD159 ■ 31-024911-00		JJ498 (31-026923-00)		NB971 ■ 45x67x10mm, FPM (50-305913-50) NB974 ■ 93x114x13mm, FPM (50-319192-00)			
HBS061 ⊗ (22-26073B) M10x1.50x115mm (x4) M10x1.50x102mm (x14)	JD475 ■ (x8) 50-027823-00 JD5225 ■ (31-027824-00)	JM5112 50-027965-00 JM5157 (x4) 50-027969-00	JH5082 (31-029265-00)	HR5056 ■ 24-30704-41/0	NB973 ■ 45x67x8mm, FPM (50-305910-50) NB974 ■ 93x114x13mm, FPM (50-319192-00)			
HBS058 ⊗ (22-26069B) M10x1.50x80mm (x4) M10x1.50x115mm (x5) M10x1.50x102mm (x9)	JD158 ■ JD159 ■ 31-024911-00	JN572 [196] 50-026030-00 JN619 [195] 50-026031-00	JJ498 (31-026923-00)	HR575 ■ 24-30672-71/0	NB971 ■ 45x67x10mm, FPM (50-305913-50) NB974 ■ 93x114x13mm, FPM (50-319192-00)	KK5683 [160]		
HBS150 ⊗ (22-26009B) M12x1.75x102mm (x10)	JD160 ■ (31-027310-00) →Eng.0-003440 →Eng.2-000017 JD5226 ■ (x2) (50-028038-00) Eng.0-003441 → Eng.2-000018 → JD161 ■ 31-027309-10	JN911 50-027307-00 HM5057 ■ 24-27307-50/0	JJ499 (31-027311-00)	HR5085 ■ (x4)	NB973 ■ 45x67x8mm, FPM (50-305910-50) NB974 ■ 93x114x13mm, FPM (50-319192-00)	JM5111 (x4) [119]		
HBS292 ⊗ (22-26011B) M12x1.75x102mm (x10)	JD5378 ■ (x4) (50-029975-00) JD5380 ■ (31-029977-00) (MLS)	HM5170 24-29264-00/0 OM 611.962	JH5082 [6] (31-029265-00)	HR5085 ■ (x4)	NA5131 ■ 45x67x8mm, PTFE (50-319436-00) NA5074 ■ [3] 93x133.5x15.5mm, PTFE (50-319396-00)	NA5248 [2]■		











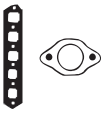

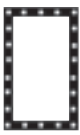

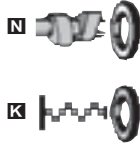

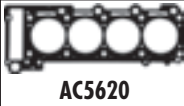







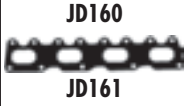





MERCEDES-BENZ

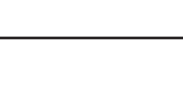

KW/PS



C-Class C 200 CDI (W202) Diesel 03/98 → 05/00 36						AC5620 (MLS), 1.20mm 30-029263-00	CC5620 (21-29263-30/0)	EC5620 22-29263-00/0
C-Class C 200 T CDI (S202) Diesel 03/98 → 03/01								
C-Class C 220 CDI (W202) Diesel 09/97 → 05/00								
C-Class C 220 T CDI (S202) Diesel 09/97 → 03/01								
OM 611.960	2151	4	88.00	Common Rail	85/115/ 116/ 156			
C-Class C 200 CDI (W203) Diesel 04/03 → 37						AC5620 (MLS), 1.20mm 30-029263-00	CC5620 (21-29263-30/0)	EC5620 22-29263-00/0
C-Class C 220 CDI (S203) Diesel 03/01 →								
C-Class C 220 CDI (W203) Diesel 05/00 →								
C-Class Coupe C 200 CDI (CL203) Diesel 07/03 →								
C-Class Coupe C 220 CDI (CL203) Diesel 03/01 →								
OM 646.962	2148	4	88.00	Direct Injection, DOHC	75-90/ 102- 122			
OM 611.962	2148	4	88.00	Direct Injection, DOHC	85-105/ 116- 143			
OM 646.963	2148	4	88.00	Direct Injection, DOHC	110/150			
C-Class C 220 (W202) 03/93 → 05/00 38						BZ880 (Fibre) 30-027462-10	DV810 <input type="checkbox"/> <input type="checkbox"/> 21-27462-50/0	EV810 22-27311-50/0
M 111.961	2199	4	89.90		110/150			
C-Class C 220 D (W202) Diesel 08/93 → 05/00 39						BZ860 (Fibre) 30-027829-00	DZ860 <input type="checkbox"/> <input type="checkbox"/> 21-27829-50/0	HC5005 (22-26923-50/0)
C-Class C 220 T D (S202) Diesel 06/96 → 03/01								
OM 604.910	2155	4	89.00	DOHC	55-70/ 75-95			
C-Class C 230 (W202) 06/96 → 06/97 40						BZ900 (Fibre) 30-027971-00	DZ900 <input type="checkbox"/> <input type="checkbox"/> 21-27971-51/0	EV810 22-27311-50/0
C-Class C 230 T (S202) 06/96 → 06/98								
M 111.974	2295	4	90.90	Injection, DOHC	110/150			
C-Class C 230 Kompressor (W202) 10/95 → 05/00 41						BZ890 (Fibre) 30-028037-00	DZ891 <input type="checkbox"/> <input type="checkbox"/> <input type="checkbox"/> <input type="checkbox"/> 21-28037-51/0	EV810 22-27311-50/0
C-Class C 230 T Kompressor (S202) 06/97 → 09/00								
M 111.975	2295	4	90.90	Injection, DOHC	142/193			
C-Class Coupe C 230 Kompressor (CL203) 03/01 → 05/02 42						BZ890 (Fibre) 30-028037-00	DZ891 <input type="checkbox"/> <input type="checkbox"/> <input type="checkbox"/> <input type="checkbox"/> 21-28037-51/0	
M 111.981	2295	4	90.90	Injection, DOHC	145/197			
C-Class C 240 (W202) 06/97 → 05/00 43						AE5730 (MLS), 0,65mm, 2 Notches <input checked="" type="checkbox"/> (30-029986-00)		
C-Class C 240 T (S202) 06/97 → 09/00								
M 112.910	2398	6	83.20	V6	125/170	AE5740 (MLS), 0,65mm, 2 Notches <input checked="" type="checkbox"/> (30-029987-00)		
C-Class C 230 (CL203) 01/05 → 44						AG8400 (MLS) <input checked="" type="checkbox"/> 30-030050-00		
C-Class C 230 (S203) 01/05 →								
C-Class C 230 (W203) 01/05 →								
M 272.920	2496	6	88.00	Injection, V6	150/204	AG8390 (MLS) <input checked="" type="checkbox"/> 30-030049-00		
C-Class C 250 D (W202) Diesel 05/93 → 05/00 45						BY590 (Fibre) 30-027830-00	DY590 <input type="checkbox"/> <input type="checkbox"/> <input type="checkbox"/> <input type="checkbox"/> 21-27830-50/0	EY590 22-26946-50/0
OM 605.910	2497	5	87.00		83/113			

								
HBS292 Ⓢ (22-26011B) M12x1.75x102mm (x10)	JD5377 ■ (31-029974-00) JD5380 ■ (31-029977-00) (MLS)	HM5170 24-29264-00/0	JH5082 [6] (31-029265-00)	HR5085 ■ (x4)	NA5131 ■ 45x67x8mm, PTFE (50-319436-00) NA5074 ■ [3] 93x133.5x15.5mm, PTFE (50-319396-00)			 AC5620  AE5740  BY590  BZ860  BZ880  BZ890  BZ900  JD160  JD161  JD475  JD476  JD5225  JD5226  JD5377  JD5378  JD5380  JD5385  JD5386  JM5157
HBS292 Ⓢ (22-26011B) M12x1.75x102mm (x10)	JD5378 ■ (x4) (50-029975-00) JD5380 ■ (31-029977-00) (MLS)	HM5170 24-29264-00/0 OM 611.962	JH5082 [6] (31-029265-00)	HR5085 ■ (x4)	NA5131 ■ 45x67x8mm, PTFE (50-319436-00) NA5074 ■ [3] 93x133.5x15.5mm, PTFE (50-319396-00)		NA5248 [2]■	 JN911  JP022  JH5082  JJ498  JJ499  JJ543
HBS150 Ⓢ (22-26009B) M12x1.75x102mm (x10)	JD160 ■ (31-027310-00) JD161 ■ 31-027309-10	JN911 50-027307-00 HM5057 ■ 24-27307-50/0	JJ499 (31-027311-00)	HR5085 ■ (x4)	NB973 ■ 45x67x8mm, FPM (50-305910-50) NB974 ■ 93x114x13mm, FPM (50-319192-00)		JM5111 (x4) [119]	
HBS061 Ⓢ (22-26073B) M10x1.50x115mm (x4) M10x1.50x102mm (x14)	JD475 ■ (x8) 50-027823-00 JD5225 ■ (31-027824-00)	JM5112 50-027965-00 JM5157 (x4) 50-027969-00	JJ498 (31-026923-00)	HR791 ■ 24-30614-76/0 →Eng.0-031329 →Eng.2-006455 HR5056 ■ 24-30704-41/0 Eng.0-031330→ Eng.2-006456→	NB973 ■ 45x67x8mm, FPM (50-305910-50) NB974 ■ 93x114x13mm, FPM (50-319192-00)			
HBS150 Ⓢ (22-26009B) M12x1.75x102mm (x10)	JD5226 ■ (x2) (50-028038-00) JD161 ■ 31-027309-10	JN911 50-027307-00 HM5057 ■ 24-27307-50/0	JJ499 (31-027311-00)	HR5085 ■ (x4)	NB973 ■ 45x67x8mm, FPM (50-305910-50) NB974 ■ 93x114x13mm, FPM (50-319192-00)		JM5111 (x4) [119]	
HBS150 Ⓢ (22-26009B) M12x1.75x102mm (x10)	JD5226 ■ (x2) (50-028038-00) JD161 ■ 31-027309-10	JN911 50-027307-00 HM5057 ■ 24-27307-50/0	JJ499 (31-027311-00)	HR5085 ■ (x4)	NB973 ■ 45x67x8mm, FPM (50-305910-50) NB974 ■ 93x114x13mm, FPM (50-319192-00)		JM5111 (x4) [119]	
HBS150 Ⓢ (22-26009B) M12x1.75x102mm (x10)	JD161 ■ 31-027309-10	JN911 50-027307-00 HM5057 ■ 24-27307-50/0	JJ499 (31-027311-00)	HR5085 ■ (x4)	NB973 ■ 45x67x8mm, FPM (50-305910-50) NB974 ■ 93x114x13mm, FPM (50-319192-00)		JM5111 (x4) [119]	
HBS463 (x2) (22-26020B) M11x1.5x141mm (x8)	JD5385 ■ (x2) (31-029992-00) JD5386 ■ (x6) (31-029993-00)	JM5236 ■ (50-029990-00) JM5237 ■ (50-029991-00)			NA5131 ■ 45x67x8mm, PTFE (50-319436-00) NA5168 ■ 93x114x11.5mm, PTFE (50-319437-00)			
		HR397 [57] 34-000410-00	HR397 [57] 34-000410-00	HR5062 ■ 24-30614-73/0	NA5131 ■ 45x67x8mm, PTFE (50-319436-00)			
HBS062 Ⓢ (22-26074B) M10x1.50x115mm (x5) M10x1.50x102mm (x17)	JD475 ■ 50-027823-00 JD476 ■	JM5157 (x5) 50-027969-00 JP022 50-027967-00	JJ543 (31-026946-00)	HR804 ■ 24-30704-42/0	NB973 ■ 45x67x8mm, FPM (50-305910-50) NB974 ■ 93x114x13mm, FPM (50-319192-00)			







MERCEDES-BENZ

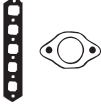

KW/PS

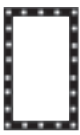

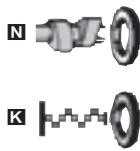
C-Class C 250 T Turbo-D (S202) Diesel 06/96 → 03/01 46						BZ870 (MLS) 30-028370-00	DZ870 21-28370-50/0	EY590 22-26946-50/0
C-Class C 250 Turbo-D (W202) Diesel 10/95 → 05/00								
OM 605.960	2497	5	87.00	DOHC	110/150			
C-Class C 240 (S203) 03/01 → 47						AE5750 (MLS) 30-029988-00		
C-Class C 240 (W203) 05/00 →								
C-Class C 240 T (S202) 09/00 → 03/01						AE5760 (MLS) 30-029989-00		
M 112.912	2398	6	89.90	V6	125/170			
M 112.915	2597	6	89.90	V6	125/170			
M 112.916	2597	6	89.90	Injection, SOHC, V6	125/170			
C-Class C 270 CDI (S203) Diesel 03/01 → 48						AD5720 (MLS), 1.20mm 30-029696-00	CD5720 21-29696-00/0	ED5720 (22-30373-00/0)
C-Class C 270 CDI (W203) Diesel 12/00 →								
OM 612.962	2685	5	88.00	Direct Injection, DOHC	125/170			
C-Class C 280 (W202) 06/97 → 05/00 49						AE5750 (MLS) 30-029988-00		
C-Class C 280 T (S202) 06/97 → 03/01								
M 112.920	2799	6	89.90	V6	145-150/197-204	AE5760 (MLS) 30-029989-00		
C-Class C 280 (W202) 05/93 → 05/00 50						AE5330 (Fibre), 1.24mm 30-027354-30	CE5330 21-27354-51/0	
M 104.941	2799	6	89.90		142/193			
C-Class C 320 CDI (S203) Diesel 06/05 → 51						AH5010 (MLS) 30-030364-00	CH5010 21-30364-00/0	
C-Class C 320 CDI (S204) Diesel 08/07 →								
C-Class C 320 CDI (W204) Diesel 01/07 →						AH5020 (MLS) 30-030363-00		
C-Class C 320 CDI 4-matic (S204) Diesel 08/07 →								
C-Class C 320 CDI 4-matic (W204) Diesel 07/07 →						AG8400 (MLS) 30-030050-00		
C-Class C 320 CDI (W203) Diesel 01/05 →								
OM 642.910	2987	6	83.00	Direct Injection	165/224	AG8390 (MLS) 30-030049-00		
OM 642.961	2987	6	83.00	Direct Injection, DOHC, V6	165/224			
OM 642.960	2987	6	83.00	Direct Injection, DOHC, V6				
C-Class C 280 (S203) 01/05 → 52						AG8400 (MLS) 30-030050-00		
C-Class C 280 (W203) 01/05 →								
M 272.940	2996	6	88.00	Injection, V6	170/231			
C-Class C 30 CDI AMG (S203) Diesel 01/03 → 53						AD5720 (MLS), 1.20mm 30-029696-00	CD5720 21-29696-00/0	ED5720 (22-30373-00/0)
C-Class C 30 CDI AMG (W203) Diesel 01/03 →								
C-Class Coupe C 30 CDI AMG (CL203) Diesel 09/02 →						AG8400 (MLS) 30-030050-00		
OM 612.990	2950	5	88.00	Direct Injection, DOHC	170/231			
C-Class C 32 AMG Kompressor (S203) 03/01 → 54						AE5750 (MLS) 30-029988-00		
C-Class C 32 AMG Kompressor (W203) 02/01 →								
C-Class C 320 (S203) 03/01 →						AE5760 (MLS) 30-029989-00		
C-Class C 320 (W203) 05/00 →								
C-Class Coupe C 32 AMG Kompressor (CL203) 05/02 →						AE5760 (MLS) 30-029989-00		
C-Class Coupe C 320 (CL203) 09/02 →								
M 112.946	3199	6	89.90	V6	160/218			
M 112.953	3199	6	89.90	Injection, V6	160/218			
M 112.961	3199	6	89.90	Injection, V6	260/354			

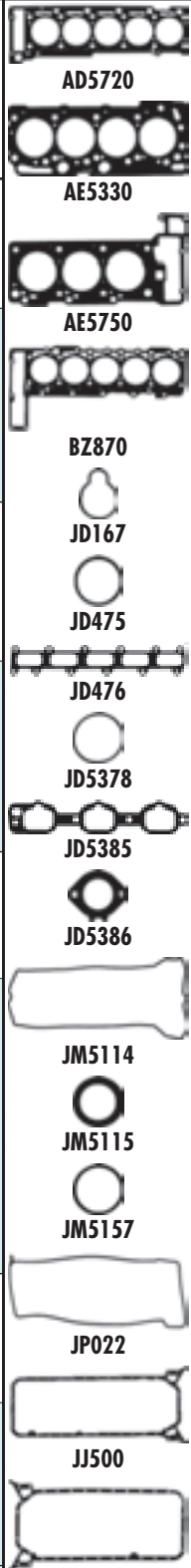
								
HBS062 Ⓢ (22-26074B) M10x1.50x115mm (x5) M10x1.50x102mm (x17)	JD475 ■ 50-027823-00 JD476 ■	JM5157 (x5) 50-027969-00 JP022 50-027967-00	JJ543 (31-026946-00)	HR804 ■ 24-30704-42/0	NA973 ■ 45x67x8mm, FPM (50-305910-50) NA974 ■ 93x114x13mm, FPM (50-319192-00)			AD5720 AE5330 AE5750
HBS463 (x2) (22-26020B) M11x1.5x141mm (x8)	JD5385 ■ (x2) (31-029992-00) JD5386 ■ (x6) (31-029993-00)	JM5236 ■ (50-029990-00) JM5237 ■ (50-029991-00)	HR397 [57] 34-000410-00		NA5131 ■ 45x67x8mm, PTFE (50-319436-00) NA5168 ■ 93x114x11.5mm, PTFE (50-319437-00)		NA5248 [2]■	BZ870 JD167 JD475 JD476 JD5378 JD5385 JD5386
HBS293 Ⓢ (22-26010B) M12x1.75x102mm (x12)	JD5378 ■ (x5) (50-029975-00) JD5798 ■ 31-030177-00	JM7028 (50-030203-00) HM5274 ■ 24-30181-00/0	JJ543 (31-026946-00)	HR5085 ■ (x5) 24-30704-45/0	NA5131 ■ 45x67x8mm, PTFE (50-319436-00) NA5074 ■ [3] 93x133.5x15.5mm, PTFE (50-319396-00)		NA5248 [2]■	JR5040 [45] KK5683 [160]
HBS463 (x2) (22-26020B) M11x1.5x141mm (x8)	JD5385 ■ (x2) (31-029992-00) JD5386 ■ (x6) (31-029993-00)	JM5236 ■ (50-029990-00) JM5237 ■ (50-029991-00)	HR397 [57] 34-000410-00		NA5131 ■ 45x67x8mm, PTFE (50-319436-00) NA5168 ■ 93x114x11.5mm, PTFE (50-319437-00)		NA5248 [2]■	JM5114 JM5115 JM5157
HBS152 Ⓢ (22-26071B) M12x1.75x160mm (x14)	JD167 ■ (x6) 50-027358-00 JD169 ■ (x2) (31-026443-10)	JM5114 (50-027355-10) JM5115 (x6) (50-026631-10)	JJ500 (31-026394-10)	HR5055 ■ 24-30704-45/0	NA971 ■ 45x67x10mm, FPM (50-305913-50) NA974 ■ 93x114x13mm, FPM (50-319192-00)		JR5040 [45] KK5683 [160]	
HBS474 Ⓢ (22-26025B) M12x1.75x205mm (x16)	JD5902 ■ (x2) 31-030365-00 (MLS) JE5067 ■ (31-030360-00) JE5068 ■ (31-030361-00)	HR397 [57] 34-000410-00	HR397 [57] 34-000410-00	HR5062 ■ 24-30614-73/0	NA5131 ■ 45x67x8mm, PTFE (50-319436-00)		NA5248 [2]■	JP022 JJ500 JJ543
		HR397 [57] 34-000410-00	HR397 [57] 34-000410-00	HR5062 ■ 24-30614-73/0	NA5131 ■ 45x67x8mm, PTFE (50-319436-00)		NA5248 [2]■	
HBS293 Ⓢ (22-26010B) M12x1.75x102mm (x12)	JD5378 ■ (x5) (50-029975-00) JD5798 ■ 31-030177-00	JM7028 (50-030203-00) HM5274 ■ 24-30181-00/0	JJ543 (31-026946-00)	HR5085 ■ (x5) 24-30704-45/0	NA5131 ■ 45x67x8mm, PTFE (50-319436-00) NA5074 ■ [3] 93x133.5x15.5mm, PTFE (50-319396-00)		NA5248 [2]■	
HBS463 (x2) (22-26020B) M11x1.5x141mm (x8)	JD5385 ■ (x2) (31-029992-00) JD5386 ■ (x6) (31-029993-00)	JM5236 ■ (50-029990-00) JM5237 ■ (50-029991-00)	HR397 [57] 34-000410-00		NA5131 ■ 45x67x8mm, PTFE (50-319436-00) NA5168 ■ 93x114x11.5mm, PTFE (50-319437-00)		NA5248 [2]■	

MERCEDES-BENZ



KW/PS



C-Class C 350 (CL203) 01/05 → 55		AG8380 (MLS), 0.65mm			
C-Class C 350 4-matic (S203) 01/05 →		(30-029487-00)			
C-Class C 350 4-matic (W203) 01/05 →		→Eng.30089232			
C-Class C 350 (S203) 01/05 →		AG8370 (MLS), 0.65mm			
C-Class C 350 (W203) 01/05 →		(30-029486-00)			
M 272.960/M 272.970	3498	6	92.90	Injection, DOHC, V6	200/272
				→Eng.30089232	
				AG8420 (MLS), 0.65mm	
				(30-030052-00)	
				Eng.30089233 →	
				AG8410 (MLS), 0.65mm	
				(30-030051-00)	
				Eng.30089233 →	
C-Class C 36 AMG (W202) 05/94 →05/00 56		AE5330 (Fibre), 1.24mm		CE5330	
M 104.941 (AMG 3.6)	3606	6	91.00	Injection	206/280
				30-027354-30	
CLC 180 Kompressor 05/08 → 57		AG8790 (MLS)		CG8790	
M 271.946	1796	4	82.00	Injection	105-125/143-170
				(30-030197-00)	
CLK Convertible 200 CGI (A209) 07/03 → 58		AG8790 (MLS)			
CLK Coupe 200 CGI (C209) 07/03 →		(30-030197-00)			
M 271.942	1796	4	82.00	Injection	125/170
CLK Convertible 200 Kompressor (A209) 02/03 → 59		AG8790 (MLS)		CG8790	
CLK Coupe 200 Kompressor (C209) 09/02 →		(30-030197-00)		21-30197-00/0	
M 271.940	1796	4	82.50	Injection	120/163
CLK Convertible 200 Kompressor (A209) 10/06 → 60		AG8790 (MLS)			
CLK Coupe 200 Kompressor (C209) 10/06 →		(30-030197-00)			
M 271.955	1796	4		Injection	135/184
CLK Convertible 200 (A208) 03/98 →03/02 61		BZ880 (Fibre)		DV810	EV810
CLK Coupe 200 (C208) 06/97 →06/02		30-027462-10		21-27462-50/0	22-27311-50/0
M 111.941	1998	4	89.90	Injection, DOHC	100/136
M 111.945	1998	4	89.90		100/136
				DZ881	
				21-27462-52/0	
				M111.945	
CLK Convertible 200 Kompressor (A208) 06/00 →03/02 62		BZ880 (Fibre)		DZ881	
CLK Coupe 200 Kompressor (C208) 06/00 →06/02		30-027462-10		21-27462-52/0	
M 111.956	1998	4	89.90		120/163
CLK Convertible 200 Kompressor (A208) 03/98 →06/00 63		BZ880 (Fibre)		DV810	EV810
CLK Coupe 200 Kompressor (C208) 06/97 →06/00		30-027462-10		21-27462-50/0	22-27311-50/0
M 111.944	1998	4	89.90	Motronic, DOHC	132-141/180-192
				→Eng.0-003440	
				→Eng.2-000017	
				DZ881	
				21-27462-52/0	
				Eng.0-003441 →	
				Eng.2-000018 →	

			HR397 [57] 34-000410-00	HR397 [57] 34-000410-00	HR280 [x2] 24-30614-75/0	NA5131 [x] 45x67x8mm, PTFE (50-319436-00)	NA5248 [2] [x]		AE5330 	
HBS152 [x] (22-26071B) M12x1.75x160mm (x14)	JD167 [x] (x6) 50-027358-00 JD169 [x] (x2) (31-026443-10)	JM5114 (50-027355-10)	JJ500 (31-026394-10)	HR5055 [x] 24-30704-45/0	NA5131 [x] 45x67x8mm, PTFE (50-319436-00) NA5168 [x] 93x114x11.5mm, PTFE (50-319437-00)	JR5040 [45] KK5683 [160]		AG8370 		
HBS459 (22-26021B) M10x1.50x165.0mm (x10)	JD5835 [x] (x4) 50-030167-00 (FPM) JD5801 [x] 31-030209-00	JM7026 50-030201-00	HR397 [57] 34-000410-00 KG664 (33-110870-00)	HR5085 [x] (x4)	NA5131 [x] 45x67x8mm, PTFE (50-319436-00)	NA5248 [2] [x]		AG8380 		
HBS459 (22-26021B) M10x1.50x165.0mm (x10)	JD5801 [x] 31-030209-00	JM7026 50-030201-00	HR397 [57] 34-000410-00	HR5085 [x] (x4)	NA5131 [x] 45x67x8mm, PTFE (50-319436-00)	NA5248 [2] [x]		BZ880 		
HBS459 (22-26021B) M10x1.50x165.0mm (x10)	JD5835 [x] (x4) 50-030167-00 (FPM) JD5801 [x] 31-030209-00	JM7026 50-030201-00	HR397 [57] 34-000410-00 KG664 (33-110870-00)	HR5085 [x] (x4)	NA5131 [x] 45x67x8mm, PTFE (50-319436-00)	NA5248 [2] [x]		JD160 		
HBS459 (22-26021B) M10x1.50x165.0mm (x10)	JD5835 [x] (x4) 50-030167-00 (FPM) JD5801 [x] 31-030209-00	JM7026 50-030201-00		HR5085 [x] (x4)	NA5131 [x] 45x67x8mm, PTFE (50-319436-00)	NA5248 [2] [x]		JD161 		
HBS459 (22-26021B) M10x1.50x165.0mm (x10)	JD5835 [x] (x4) 50-030167-00 (FPM) JD5801 [x] 31-030209-00	JM7026 50-030201-00		HR5085 [x] (x4)	NA5131 [x] 45x67x8mm, PTFE (50-319436-00)	NA5248 [2] [x]		JD167 		
HBS150 [x] (22-26009B) M12x1.75x102mm (x10)	JD160 [x] (31-027310-00) M111.941 JD5226 [x] (x2) (50-028038-00) M111.945 JD161 [x] 31-027309-10	JN911 50-027307-00 HM5057 [x] 24-27307-50/0	JJ499 (31-027311-00)	HR5085 [x] (x4)	NB973 [x] 45x67x8mm, FPM (50-305910-50) NB974 [x] 93x114x13mm, FPM (50-319192-00)	JM5111 (x4) [119]		JD5226 		
HBS150 [x] (22-26009B) M12x1.75x102mm (x10)		HM5057 [x] 24-27307-50/0	JH5082 (31-029265-00)	HR5085 [x] (x4)	NB973 [x] 45x67x8mm, FPM (50-305910-50) NB974 [x] 93x114x13mm, FPM (50-319192-00)	NA5248 [2] [x]		JM5114 		
HBS150 [x] (22-26009B) M12x1.75x102mm (x10)	JD160 [x] (31-027310-00) →Eng.0-003440 →Eng.2-000017 JD5226 [x] (x2) (50-028038-00) Eng.0-003441→ Eng.2-000018→ JD161 [x] 31-027309-10	JN911 50-027307-00 HM5057 [x] 24-27307-50/0	JJ499 (31-027311-00)	HR5085 [x] (x4)	NB973 [x] 45x67x8mm, FPM (50-305910-50) NB974 [x] 93x114x13mm, FPM (50-319192-00)	JM5111 (x4) [119]		JN911 		
								JH5082 		
								JJ499 		
								JJ500 		

MERCEDES-BENZ



KW/PS



CLK 220 CDI (C209) Diesel	01/05 →			64	AC5620 (MLS), 1.20mm 30-029263-00	CC5620 (21-29263-30/0)	EC5620 22-29263-00/0
OM 646.966	2148	4	88.00	110/150			
CLK Convertible 230 Kompressor (A208)	06/00 → 03/02			65	BZ890 (Fibre) 30-028037-00	DZ891 21-28037-51/0	
CLK Coupe 230 Kompressor (C208)	06/00 → 06/02						
M 111.982	2295	4	90.90	105- 142/ 143/ 193			
CLK Convertible 230 Kompressor (A208)	03/98 → 06/00			66	BZ890 (Fibre) 30-028037-00	DZ891 21-28037-51/0	EV810 22-27311-50/0
CLK Coupe 230 Kompressor (C208)	06/97 → 06/00						
M 111.973/M 111.975	2295	4	90.90	Injection, DOHC	142/193		
CLK Convertible 240 (A209)	02/03 →			67	AE5750 (MLS) 30-029988-00		
CLK Coupe 240 (C209)	06/02 →				AE5760 (MLS) 30-029989-00		
M 112.912	2597	6	89.90	V6	125/170		
CLK Coupe 270 CDI (C209) Diesel	10/02 →			68	AD5720 (MLS), 1.20mm 30-029696-00	CD5720 21-29696-00/0	ED5720 (22-30373-00/0)
OM 612.962/OM 612.967	2685	5	88.00	Direct Injection, DOHC	125/170		
CLK 320 CDI (A209) Diesel	03/05 →			69	AH5010 (MLS) 30-030364-00	CH5010 21-30364-00/0	
CLK 320 CDI (C209) Diesel	01/05 →				AH5020 (MLS) 30-030363-00		
OM 642.910	2987	6	83.00	Direct Injection	165/224		
CLK Convertible 320 (A208)	03/98 → 03/02			70	AE5750 (MLS) 30-029988-00		
CLK Convertible 320 (A209)	02/03 →				AE5760 (MLS) 30-029989-00		
CLK Coupe 320 (C208)	06/97 → 06/02						
CLK Coupe 320 (C209)	06/02 →						
M 112.955	3199	6	89.90	Injection, V6	160/218		
M 112.940	3199	6	89.90	V6	160- 162/ 218- 220		
CLK Convertible 350 (A209)	01/05 →			71	AG8380 (MLS), 0.65mm (30-029487-00) →Eng.30089232		
CLK Coupe 350 (C209)	01/05 →				AG8370 (MLS), 0.65mm (30-029486-00) →Eng.30089232		
M 272.960	3498	6	92.90	Injection, DOHC, V6	200/272		
					AG8420 (MLS), 0.65mm (30-030052-00) Eng.30089233 →		
					AG8410 (MLS), 0.65mm (30-030051-00) Eng.30089233 →		
CLK 500 (C209)	06/06 →			72	AG8440 (MLS) (30-029954-00)		
M 273.965	5461	8	98.00	Injection, DOHC, V8	285/388		
					AG8430 (MLS) (30-029953-00)		

HBS292 [22-26011B] M12x1.75x102mm (x10)	JD5378 (x4) (50-029975-00) JD5380 (31-029977-00) (MLS)		JH5082 [6] (31-029265-00)	HR5085 (x4)	NA5131 45x67x8mm, PTFE (50-319436-00) NA5074 [3] 93x133.5x15.5mm, PTFE (50-319396-00)	NA5248 [2]	 AC5620	 AD5720	 AE5750	
HBS150 [22-26009B] M12x1.75x102mm (x10)	JD161 31-027309-10	JN911 50-027307-00 HM5057 24-27307-50/0	JJ499 (31-027311-00)	HR5085 (x4)	NB973 45x67x8mm, FPM (50-305910-50) NB974 93x114x13mm, FPM (50-319192-00)	JM5111 (x4) [119]	 AG8370	 AG8380		
HBS150 [22-26009B] M12x1.75x102mm (x10)	JD5226 (x2) (50-028038-00) JD161 31-027309-10	JN911 50-027307-00 HM5057 24-27307-50/0	JJ499 (31-027311-00)	HR5085 (x4)	NB973 45x67x8mm, FPM (50-305910-50) NB974 93x114x13mm, FPM (50-319192-00)	JM5111 (x4) [119]	 BZ890	 JD161		
HBS463 (x2) [22-26020B] M11x1.5x141mm (x8)	JD5385 (x2) (31-029992-00) JD5386 (x6) (31-029993-00)	JM5236 (50-029990-00) JM5237 (50-029991-00)	HR397 [57] 34-000410-00		NA5131 45x67x8mm, PTFE (50-319436-00) NA5168 93x114x11.5mm, PTFE (50-319437-00)	NA5248 [2]	 JD5226	 JD5378		
HBS293 [22-26010B] M12x1.75x102mm (x12)	JD5378 (x5) (50-029975-00) JD5798 31-030177-00	JM7028 (50-030203-00) HM5274 24-30181-00/0	JJ543 (31-026946-00)	HR5085 (x5)	NA5131 45x67x8mm, PTFE (50-319436-00) NA5074 [3] 93x133.5x15.5mm, PTFE (50-319396-00)	NA5248 [2]	 JD5380	 JD5385		
HBS474 [22-26025B] M12x1.75x205mm (x16)	JD5902 (x2) 31-030365-00 (MLS) JE5067 (31-030360-00) JE5068 (31-030361-00)	HR397 [57] 34-000410-00	HR397 [57] 34-000410-00		NA5131 45x67x8mm, PTFE (50-319436-00)	NA5248 [2]	 JD5386	 JN911		
HBS463 (x2) [22-26020B] M11x1.5x141mm (x8)	JD5385 (x2) (31-029992-00) JD5386 (x6) (31-029993-00)	JM5236 (50-029990-00) JM5237 (50-029991-00)	HR397 [57] 34-000410-00		NA5131 45x67x8mm, PTFE (50-319436-00) NA5168 93x114x11.5mm, PTFE (50-319437-00)		 JH5082	 JJ499		
		HR397 [57] 34-000410-00	HR397 [57] 34-000410-00	HR5062 24-30614-73/0	NA5131 45x67x8mm, PTFE (50-319436-00)	NA5248 [2]	 JJ543			
		HR397 [57] 34-000410-00	HR397 [57] 34-000410-00	HR791 (x2) 24-30614-76/0	NA5131 45x67x8mm, PTFE (50-319436-00) NA5168 93x114x11.5mm, PTFE (50-319437-00)					







MERCEDES-BENZ

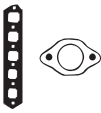

KW/PS

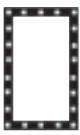

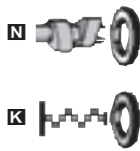
Model	Year Range	Power (KW/PS)	Configuration	Engine Code	Accessories
CLS 320 CDI (C219) Diesel OM 642.910	01/05 →	165/224	Direct Injection	AH5010 (MLS) 30-030364-00 AH5020 (MLS) 30-030363-00	CH5010 21-30364-00/0
CLS 350 (C219) M 272.964	10/04 →	200/272	Injection, DOHC, V6	AG8380 (MLS), 0.65mm (30-029487-00) →Eng.30089232 AG8370 (MLS), 0.65mm (30-029486-00) →Eng.30089232 AG8420 (MLS), 0.65mm (30-030052-00) Eng.30089233 → AG8410 (MLS), 0.65mm (30-030051-00) Eng.30089233 →	
CLS 350 (C219) M 272.985	04/06 →	200/272		AG8420 (MLS), 0.65mm (30-030052-00) AG8410 (MLS), 0.65mm (30-030051-00)	
E-Class E 200 (W211) E-Class E 200 (W211) E-Class E 200 Kompressor (W211)	11/02 → 03/04 → 11/02 →	105-125/ 143-170 120/163	Injection DOHC	AG8790 (MLS) (30-030197-00)	CG8790 21-30197-00/0
E-Class 200 D (W123) Diesel OM 615.940	07/76 →11/85	40/44/ 55/60		BG990 (Fibre) 30-023924-10	
E-Class 200 D (W124) Diesel E-Class 200 T D (S124) Diesel	12/84 →06/93 09/85 →08/91	53-55/ 72		BT540 (Fibre) 30-027106-20	DT540 21-27106-51/0 DT541
E-Class 200 E (W123) E-Class 200 T (S123)	06/80 →11/85 11/80 →11/85	62/93/ 84/126 66/77/ 90/105	Injection	BH870 (Fibre) 30-026004-10	DH870 [195] (21-26004-56/0) EH872 22-26812-04/0
E-Class 200 E (W124) M 102.922	12/85 →05/90	62/93/ 84/126	Injection	BH870 (Fibre) 30-026004-10	DH870 [195] (21-26004-56/0) EH872 22-26812-04/0 Eng.0-029 223 → Eng.2-011 934 →

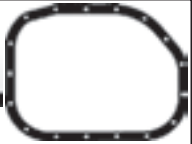
									
HBS474 Ⓢ (22-26025B) M12x1.75x205mm (x16)	JD5902 ■ (x2) 31-030365-00 (MLS) Ⓢ JE5067 ■ (31-030360-00) Ⓢ JE5068 ■ (31-030361-00)	HR397 [57] 34-000410-00	HR397 [57] 34-000410-00			NA5131 ■ 45x67x8mm, PTFE (50-319436-00)		AG8370	JH683
		HR397 [57] 34-000410-00	HR397 [57] 34-000410-00	HR280 ■ (x2) 24-30614-75/0		NA5131 ■ 45x67x8mm, PTFE (50-319436-00)	NA5248 [2]■	AG8380	JJ488
		HR397 [57] 34-000410-00	HR397 [57] 34-000410-00	HR5062 ■ 24-30614-73/0		NA5131 ■ 45x67x8mm, PTFE (50-319436-00)		BG990	JJ498
HBS459 (22-26021B) M10x1.50x165.0mm (x10)	JD5835 ■ (x4) 50-030167-00 (FPM) JD5801 ■ 31-030209-00	JM7026 50-030201-00	HR397 [57] 34-000410-00	HR5085 ■ (x4)		NA5131 ■ 45x67x8mm, PTFE (50-319436-00)		BH870	
HBS045 Ⓢ (22-26067B) M12x1.75x105mm (x4) M12x1.75x145mm (x6) M12x1.75x120mm (x8)	JB162 (31-024970-20)	JM848 50-022825-00	JH683 (31-026944-00)			NB975 ■ 45x74.5x12mm, FPM (50-306557-50) PA815 ■ 78x94x8mm (31-019993-30)		BT540	
HBS058 Ⓢ (22-26069B) M10x1.50x80mm (x4) M10x1.50x115mm (x5) M10x1.50x102mm (x9)	JD158 ■ JD159 ■ 31-024911-00	JN572 [196] 50-026030-00 JN619 [195] 50-026031-00	JJ498 (31-026923-00)	HR757 ■ 24-30672-71/0		NB971 ■ 45x67x10mm, FPM (50-305913-50) NB974 ■ 93x114x13mm, FPM (50-319192-00)	KK5683 [160]	JD158	
HBS047 Ⓢ (22-26065B) M12x1.75x120mm (x10)	JD291 ■ (31-025684-10) JD292 ■ (x4) 31-026634-10 Ⓢ JE5026 (31-024888-10)	JN454 [195] 50-024959-10 JN607 [196] 50-025120-10	JJ488 (31-026812-00)	HR756 ■ 24-30615-70/0		NB971 ■ 45x67x10mm, FPM (50-305913-50) NB974 ■ 93x114x13mm, FPM (50-319192-00)		JD159	
HBS047 Ⓢ (22-26065B) M12x1.75x120mm (x10)	JD291 ■ (31-025684-10) JD292 ■ (x3) 31-026634-10 JD293 ■ 31-026635-10	JN454 [195] 50-024959-10 JN607 [196] 50-025120-10	JJ488 (31-026812-00)	HR756 ■ 24-30615-70/0		NB971 ■ 45x67x10mm, FPM (50-305913-50) NB974 ■ 93x114x13mm, FPM (50-319192-00)		JD159	

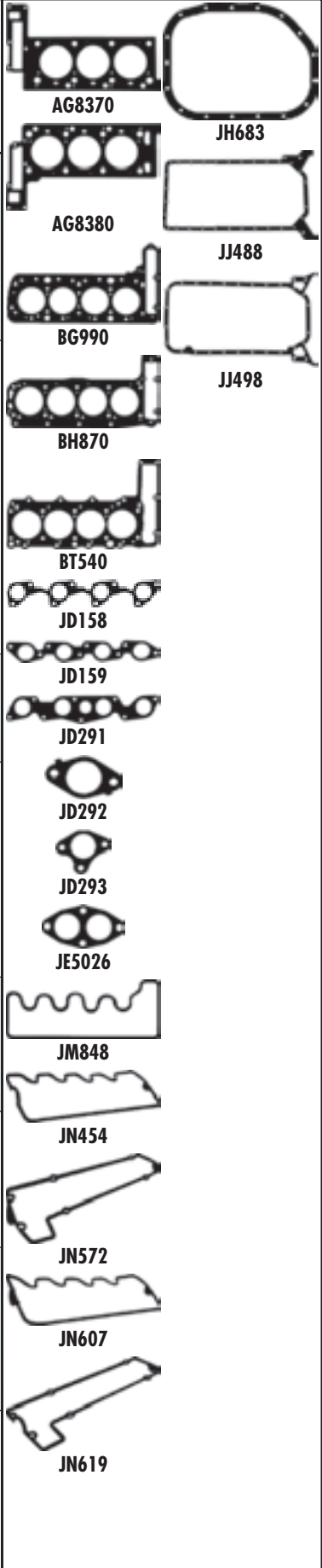

MERCEDES-BENZ



KW/PS

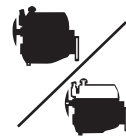

E-Class 200 E (W124)		09/88 → 08/92		81		BH870 (Fibre)	DH873 [195]	EH872
E-Class 200 TE (S124)		09/88 → 08/92				30-026004-10	21-26004-55/0	22-26812-04/0
M 102.962/M 102.963	1997	4	89.00	Injection	62/93/ 84/126		DH876 [196]	Eng.0-029 223→
							21-26004-20/0	Eng.2-011 934→
E-Class 200 E (W124)		10/92 → 06/93		82		BZ880 (Fibre)	DV810	EV810
E-Class 200 TE (S124)		10/92 → 06/93				30-027462-10	21-27462-50/0	22-27311-50/0
E-Class Convertible E 200 (A124)		06/93 → 03/98						
E-Class Coupe E 200 (C124)		06/93 → 06/97						
E-Class E 200 (W124)		06/93 → 06/95						
E-Class E 200 T (S124)		06/93 → 06/96						
M 111.940	1998	4	89.90	Injection, DOHC	100/136			
E-Class 200 T (S124)		09/85 → 05/90		83		BH870 (Fibre)	DH870 [195]	EH872
M 102.922	1997	4	89.00	Injection	62/93/ 84/126	30-026004-10	(21-26004-56/0)	22-26812-04/0
							DH872	
							21-26004-57/0	
E-Class 200 T D (S124) Diesel		09/88 → 08/91		84		BT540 (Fibre)	DT540	EM720
E-Class E 200 D (W124) Diesel		06/93 → 06/95				30-027106-20	21-27106-51/0	22-24895-01/0
OM 601.912	1978	4	87.00		53-55/ 72		DT541	
E-Class E 200 (W210)		06/95 → 08/00		85		BZ880 (Fibre)	DZ881	EV810
E-Class E 200 Kompressor (W210)		06/97 → 03/02				30-027462-10	21-27462-52/0	22-27311-50/0
E-Class E 200 T Kompressor (S210)		06/97 → 03/03						
M 111.942	1998	4	89.90		100/136			
M 111.947	1998	4	89.90		137/186			
E-Class E 200 D (W210) Diesel		01/96 → 03/02		86				
OM 604.917	2155	4	87.00		65/88			
E-Class E 200 Kompressor (W210)		08/00 → 03/02		87		BZ880 (Fibre)		
E-Class E 200 T Kompressor (S210)		08/00 → 03/03				30-027462-10		
M 111.957	1998	4	89.90		120/163			
E-Class E 200 T (S210)		06/96 → 08/00		88		BZ880 (Fibre)	DZ881	EV810
M 111.942	1998	4	89.90		100/136	30-027462-10	21-27462-52/0	22-27311-50/0
E-Class E 220 CDI (W211) Diesel		03/02 →		89		AC5620 (MLS), 1.20mm	CC5620	EC5620
E-Class E 220 T CDI (S211) Diesel		03/03 →				30-029263-00	(21-29263-30/0)	22-29263-00/0
OM 646.961	2148	4	88.00	Direct Injection, DOHC	110/150			
E-Class E 200 CDI (W211) Diesel		04/06 →		90				EC5620
E-Class E 220 CDI (W211) Diesel		04/06 →						22-29263-00/0
E-Class E 220 T CDI (S211) Diesel		04/06 →						
OM 646.820/OM 646.821	2148	4	88.00	Direct Injection, DOHC				

HBS047 Ⓢ (22-26065B) M12x1.75x120mm (x10)	JD182 ■ 31-026877-00 JD291 ■ (31-025684-10) JD292 ■ (x3) 31-026634-10 JD293 ■ 31-026635-10	JN454 [195] 50-024959-10 JN607 [196] 50-025120-10	JJ488 (31-026812-00)	HR756 ■ 24-30615-70/0	NB973 ■ 45x67x8mm, FPM (50-305910-50) NB974 ■ 93x114x13mm, FPM (50-319192-00)		 AC5620	 JN607
HBS150 Ⓢ (22-26009B) M12x1.75x102mm (x10)	JD160 ■ (31-027310-00) JD161 ■ 31-027309-10	JN911 50-027307-00 HM5057 ■ 24-27307-50/0	JJ499 (31-027311-00)	HR5085 ■ (x4) 24-30615-70/0	NB973 ■ 45x67x8mm, FPM (50-305910-50) NB974 ■ 93x114x13mm, FPM (50-319192-00)	JM5111 (x4) [119]	 BH870	 JN619
HBS047 Ⓢ (22-26065B) M12x1.75x120mm (x10)	JD291 ■ (31-025684-10) JD292 ■ (x4) 31-026634-10 JD293 ■ 31-026635-10	JN454 [195] 50-024959-10 JN607 [196] 50-025120-10	JJ488 (31-026812-00)	HR756 ■ 24-30615-70/0	NB971 ■ 45x67x10mm, FPM (50-305913-50) NB974 ■ 93x114x13mm, FPM (50-319192-00)		 BT540	 JN911
HBS058 Ⓢ (22-26069B) M10x1.50x80mm (x4) M10x1.50x115mm (x5) M10x1.50x102mm (x9)	JD158 ■ JD159 ■ 31-024911-00	JN572 [196] 50-026030-00 JN619 [195] 50-026031-00	JJ498 (31-026923-00)	HR757 ■ 24-30672-71/0	NB971 ■ 45x67x10mm, FPM (50-305913-50) NB974 ■ 93x114x13mm, FPM (50-319192-00)	KK5683 [160]	 BZ880	 JH5082
HBS150 Ⓢ (22-26009B) M12x1.75x102mm (x10)	JD5226 ■ (x2) (50-028038-00) JD161 ■ 31-027309-10	JN911 50-027307-00 HM5057 ■ 24-27307-50/0	JJ499 (31-027311-00)	HR5085 ■ (x4) 24-30615-70/0	NB973 ■ 45x67x8mm, FPM (50-305910-50) NB974 ■ 93x114x13mm, FPM (50-319192-00)	JM5111 (x4) [119]	 JD158	 JD159
HBS061 Ⓢ (22-26073B) M10x1.50x115mm (x4) M10x1.50x102mm (x14)	JD475 ■ (x8) 50-027823-00 JD5225 ■ (31-027824-00)	JM5112 50-027965-00 JM5157 (x4) 50-027969-00	JH5082 (31-029265-00)	HR5056 ■ 24-30704-41/0	NA5131 ■ 45x67x8mm, PTFE (50-319436-00) NB974 ■ 93x114x13mm, FPM (50-319192-00)		 JD160	 JD161
HBS150 Ⓢ (22-26009B) M12x1.75x102mm (x10)		JN911 50-027307-00 HM5057 ■ 24-27307-50/0	JH5082 (31-029265-00)	HR5085 ■ (x4) 24-30615-70/0	NB973 ■ 45x67x8mm, FPM (50-305910-50) NB974 ■ 93x114x13mm, FPM (50-319192-00)	JM5111 (x4) [119]	 JD182	 JD291
HBS150 Ⓢ (22-26009B) M12x1.75x102mm (x10)	JD5226 ■ (50-028038-00) JD161 ■ 31-027309-10	JN911 50-027307-00 HM5057 ■ 24-27307-50/0	JH5082 (31-029265-00)	HR5085 ■ (x4) 24-30615-70/0	NB973 ■ 45x67x8mm, FPM (50-305910-50) NB974 ■ 93x114x13mm, FPM (50-319192-00)	JM5111 (x4) [119]	 JD292	 JD293
HBS292 Ⓢ (22-26011B) M12x1.75x102mm (x10)	JD5378 ■ (x4) (50-029975-00) JD5380 ■ (31-029977-00) (MLS)		JH5082 [6] (31-029265-00)	HR5085 ■ (x4) 24-30615-70/0	NA5131 ■ 45x67x8mm, PTFE (50-319436-00) NA5074 ■ [3] 93x133.5x15.5mm, PTFE (50-319396-00)	NA5248 [2]■	 JD475	 JD5225
HBS292 Ⓢ (22-26011B) M12x1.75x102mm (x10)			JH5082 (31-029265-00)	HR5085 ■ (x4) 24-30615-70/0	NA5131 ■ 45x67x8mm, PTFE (50-319436-00) NA5074 ■ [3] 93x133.5x15.5mm, PTFE (50-319396-00)		 JD5226	 JD5378
							 JD5380	 JM5157
							 JN454	 JN572











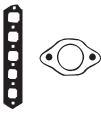

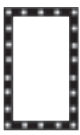



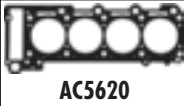

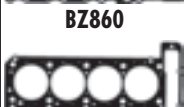





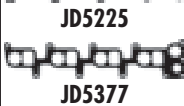













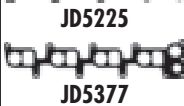

MERCEDES-BENZ



KW/PS

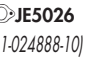

E-Class 220 E (W124)		10/92 → 06/93		91		BZ880 (Fibre) 30-027462-10	DV810 21-27462-50/0	EV810 22-27311-50/0
E-Class 220 TE (S124)		10/92 → 05/93						
E-Class Convertible E 220 (A124)		06/93 → 03/98						
E-Class Coupe 220 CE (C124)		10/92 → 05/93						
E-Class Coupe E 220 (C124)		06/93 → 06/97						
E-Class E 220 (W124)		06/93 → 06/95						
E-Class E 220 T (S124)		06/93 → 06/96						
M 111.960	2199	4	89.90		110/150			
E-Class E 200 CDI (W210) Diesel		06/98 → 03/02		92		AC5620 (MLS), 1.20mm 30-029263-00	CC5620 (21-29263-30/0) →12/99	EC5620 22-29263-00/0
E-Class E 220 CDI (W210) Diesel		07/99 → 03/02						
E-Class E 220 T CDI (S210) Diesel		07/99 → 03/03						
OM 611.961	2148	4	88.00	Direct Injection, DOHC	75-105/ 102- 143			
E-Class E 200 CDI (W211) Diesel		07/02 →		93		AC5620 (MLS), 1.20mm 30-029263-00	CC5620 (21-29263-30/0)	EC5620 22-29263-00/0
OM 646.951		2148	4	88.00	Direct Injection, DOHC			
E-Class E 220 CDI (W210) Diesel		06/98 → 07/99		94		AC5620 (MLS), 1.20mm 30-029263-00	CC5620 (21-29263-30/0)	EC5620 22-29263-00/0
E-Class E 220 T CDI (S210) Diesel		06/98 → 07/99						
OM 611.961	2148	4	88.00	Direct Injection, DOHC	75-105/ 102- 143			
E-Class E 220 D (W210) Diesel		06/95 → 03/02		95				
OM 604.912		2155	4	89.00	DOHC	55-70/ 75-95		
E-Class 230 E (W123)		04/80 → 12/85		96		BH880 (Fibre) 30-026005-10		EH872 22-26812-04/0 →Eng.0-176550 →Eng.2-133269
E-Class 230 TE (S123)		04/80 → 11/85						
E-Class Coupe 230 CE (C123)		04/80 → 12/85						
M 102.980	2299	4	95.50	Injection	100/136			
E-Class 230 E (W124)		12/84 → 06/93		97		BH880 (Fibre) 30-026005-10	DH882 [195] 21-26005-54/0	EH872 22-26812-04/0
E-Class 230 TE (S124)		09/85 → 08/92						
E-Class Coupe 230 CE (C124)		03/87 → 12/92						
M 102.982	2299	4	95.50	K-Jetronic	97-100/ 132- 136			

								
HBS150 ⊕ (22-26009B) M12x1.75x102mm (x10)	JD160 ■ (31-027310-00) JD161 ■ 31-027309-10	JN911 50-027307-00 HM5057 ■ 24-27307-50/0	JJ499 (31-027311-00)	HR5085 ■ (x4)	▣ NB973 ■ 45x67x8mm, FPM (50-305910-50) ▣ NB974 ■ 93x114x13mm, FPM (50-319192-00)	JM5111 (x4) [119]		 AC5620  BH880  BZ860  BZ880  JD160  JD161  JD182  JD292  JD293  JD475  JD5225  JD5377  JD5378  JD5380  JE5026  JM5157  JN454  JN607  JN911  JH5082
HBS292 ⊕ (22-26011B) M12x1.75x102mm (x10)	JD5377 ■ (31-029974-00) →12/99 JD5378 ■ (x4) (50-029975-00) 01/00→ JD5380 ■ (31-029977-00) (MLS)	HM5170 24-29264-00/0	JH5082 [6] (31-029265-00)	HR5085 ■ (x4)	▣ NA5131 ■ 45x67x8mm, PTFE (50-319436-00) ▣ NA5074 ■ [3] 93x133.5x15.5mm, PTFE (50-319396-00)	KA5035 [13] KA5036 [13]		 JD160  JD161  JD182
HBS292 ⊕ (22-26011B) M12x1.75x102mm (x10)	JD5378 ■ (x4) (50-029975-00) JD5380 ■ (31-029977-00) (MLS)	HM5170 24-29264-00/0 →Eng.30112421	JH5082 [6] (31-029265-00)	HR5085 ■ (x4)	▣ NA5131 ■ 45x67x8mm, PTFE (50-319436-00) ▣ NA5074 ■ [3] 93x133.5x15.5mm, PTFE (50-319396-00)	NA5248 [2]■		 JD292  JD293  JD475
HBS292 ⊕ (22-26011B) M12x1.75x102mm (x10)	JD5377 ■ (31-029974-00) →12/99 JD5378 ■ (x4) (50-029975-00) 01/00→ JD5380 ■ (31-029977-00) (MLS)	HM5170 24-29264-00/0	JH5082 [6] (31-029265-00)	HR5085 ■ (x4)	▣ NA5131 ■ 45x67x8mm, PTFE (50-319436-00) ▣ NA5074 ■ [3] 93x133.5x15.5mm, PTFE (50-319396-00)	KA5035 [13] KA5036 [13]		 JD5225  JD5377  JD5378  JD5380
HBS061 ⊕ (22-26073B) M10x1.50x115mm (x4) M10x1.50x102mm (x14)	JD475 ■ (x8) 50-027823-00 JD5225 ■ (31-027824-00)	JM5112 50-027965-00 JM5157 (x4) 50-027969-00	JJ498 (31-026923-00)	HR791 ■ 24-30614-76/0 →Eng.0-031329 →Eng.2-006455 HR5056 ■ 24-30704-41/0 Eng.0-031330→ Eng.2-006456→	▣ NB973 ■ 45x67x8mm, FPM (50-305910-50) ▣ NB974 ■ 93x114x13mm, FPM (50-319192-00)			 JE5026  JM5157
HBS047 ⊕ (22-26065B) M12x1.75x120mm (x10)	JD182 ■ 31-026877-00 JD292 ■ (x4) 31-026634-10  JE5026 (31-024888-10)	JN454 [195] 50-024959-10 JN607 [196] 50-025120-10	JJ488 (31-026812-00)	HR756 ■ 24-30615-70/0	▣ NB971 ■ 45x67x10mm, FPM (50-305913-50) →Eng.0-176550 →Eng.2-133269 ▣ NB974 ■ 93x114x13mm, FPM (50-319192-00) ▣ NB973 ■ 45x67x8mm, FPM (50-305910-50) Eng.0-176551→ Eng.2-133270→			 JN454  JN607  JN911
HBS047 ⊕ (22-26065B) M12x1.75x120mm (x10)	JD182 ■ 31-026877-00 JD292 ■ (x3) 31-026634-10 JD293 ■ 31-026635-10	JN454 [195] 50-024959-10 JN607 [196] 50-025120-10	JJ488 (31-026812-00)	HR756 ■ 24-30615-70/0	▣ NB971 ■ 45x67x10mm, FPM (50-305913-50) →Eng.0-044037 →Eng.2-041522 ▣ NB974 ■ 93x114x13mm, FPM (50-319192-00) ▣ NB973 ■ 45x67x8mm, FPM (50-305910-50) Eng.0-044038→ Eng.2-041523→			 JH5082











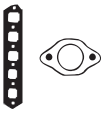

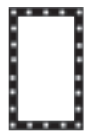

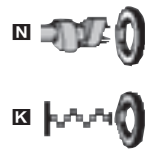







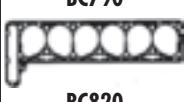





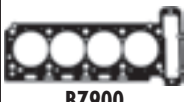

MERCEDES-BENZ



KW/PS



E-Class E 230 (W210)		06/95 → 06/97		98		BZ900 (Fibre)	DZ900 ■○	EV810
E-Class E 230 T (S210)		06/96 → 06/97				30-027971-00	21-27971-51/0	22-27311-50/0
M 111.970	2295	4	90.90	Injection, DOHC	110/150			
E-Class 240 D (W123) Diesel		03/79 → 11/85		99		BC790 (Fibre)	DC790 ■	EC790
E-Class 240 T D (S123) Diesel		09/77 → 12/85				30-024065-10	21-24065-24/0	(22-26944-01/0) GC790
OM 616.912	2399	4	91.00		46/53/ 63/72			20-24065-01/0
E-Class E 240 (W210)		06/97 → 08/00		100		AE5730 (MLS), 0,65mm, 2 Notches		
E-Class E 240 T (S210)		06/97 → 03/03				(30-029986-00)		
M 112.911	2398	6	83.20	V6	125/170	AE5740 (MLS), 0,65mm, 2 Notches		
E-Class E 240 (W211)		03/03 →		101		AE5750 (MLS)		
M 112.917	2597	6	89.90	V6	130/177	30-029988-00 AE5760 (MLS)		
E-Class 250 D (W124) Diesel		04/85 → 06/93		102		BN720 (Fibre), 1,74mm	DN722 ■ [195]	EN720
E-Class 250 T D (S124) Diesel		09/85 → 06/93				30-027216-20	21-27216-51/0	22-26946-01/0
E-Class 250 Turbo-D (W124) Diesel		09/88 → 06/93					DN723 ■ [196]	
E-Class E 250 Turbo D (S124) Diesel		06/93 → 06/96						
E-Class E 250 Turbo-D (W124) Diesel		06/93 → 06/95						
OM 602.912	2497	5	87.00		66-69/ 90-94			
OM 602A.962	2497	5	87.00		93/126			
E-Class 250 E Diesel		01/85 → 12/95		103		BN720 (Fibre), 1,74mm	DN722 ■ [195]	EN720
E-Class 250 T (S123)		05/78 → 08/82				30-027216-20	21-27216-51/0	22-26946-01/0
OM 602.911/ OM 602.912/OM 602.930	2497	5	87.00		68/92		DN723 ■ [199]	
OM 602.931	2497	5	87.00	SOHC	68/92			
OM 602.939/ OM 602.961/OM 602A.962	2497	5	87.00		68/92			
E-Class 250 E (W123)		02/76 → 07/85		104		BC820 (Fibre)	DC820	
E-Class 250 T (S123)		05/78 → 08/82				30-024067-10	(21-24067-21/0)	
M 123.921	2527	6	86.00		95-103/ 129- 140			
E-Class E 250 D (W124) Diesel		07/93 → 06/95		105		BY590 (Fibre)	DY590 ■	EY590
E-Class E 250 D (W210) Diesel		06/95 → 07/99				30-027830-00	21-27830-50/0	22-26946-50/0
E-Class E 250 T D (S124) Diesel		06/93 → 06/96						
E-Class E 250 T D (S210) Diesel		06/96 → 07/99						
OM 605.911	2497	5	87.00		83/113			
OM 605.912	2497	5	87.00	DOHC	83/113			
E-Class E 250 T Turbo-D (S210) Diesel		06/97 → 07/99		106		BZ870 (MLS)	DZ870 ■○	EY590
E-Class E 250 Turbo-D (W210) Diesel		06/97 → 07/99				30-028370-00	21-28370-50/0	22-26946-50/0
OM 605.962	2497	5	87.00	DOHC	110/150			
E-Class E 240 (W210)		08/00 → 03/02		107		AE5750 (MLS)		
E-Class E 240 T (S210)		08/00 → 03/03				30-029988-00		
M 112.914	2398	6	89.90	V6	125/170	AE5760 (MLS)		
						30-029989-00		

								
HBS150 ⊕ (22-26009B) M12x1.75x102mm (x10)	JD5226 ■ (x2) (50-028038-00) JD161 ■ 31-027309-10	JN911 50-027307-00 HM5057 ■ 24-27307-50/0	JJ499 (31-027311-00)	HR5085 ■ (x4)	NB973 ■ 45x67x8mm, FPM (50-305910-50) NB974 ■ 93x114x13mm, FPM (50-319192-00)	JM5111 (x4) [119]		 AE5740  JN621  AE5750  JN622
HBS045 ⊕ (22-26067B) M12x1.75x105mm (x4) M12x1.75x145mm (x6) M12x1.75x120mm (x8)	JB162 (31-024970-20)	JM848 50-022825-00	JH683 (31-026944-00)		NB975 ■ 45x74.5x12mm, FPM (50-306557-50) PA815 ■ 78x94x8mm (31-019993-30)			 BC790  JN911  BC820  JP022
HBS463 (x2) (22-26020B) M11x1.5x141mm (x8)	JD5385 ■ (x2) (31-029992-00) JD5386 ■ (x6) (31-029993-00)	JM5236 ■ (50-029990-00) JM5237 ■ (50-029991-00)			NA5131 ■ 45x67x8mm, PTFE (50-319436-00) NA5168 ■ 93x114x11.5mm, PTFE (50-319437-00)			 BN720  JH683
HBS463 (x2) (22-26020B) M11x1.5x141mm (x8)	JD5385 ■ (x2) (31-029992-00) JD5386 ■ (x6) (31-029993-00)	JM5236 ■ (50-029990-00) JM5237 ■ (50-029991-00)			NA5131 ■ 45x67x8mm, PTFE (50-319436-00) NA5168 ■ 93x114x11.5mm, PTFE (50-319437-00)			 BY590  JJ499
HBS059 ⊕ (22-26006B) M10x1.50x80mm (x5) M10x1.50x115mm (x6) M10x1.50x102mm (x11)	JD298 ■ 31-025171-30 JD299 ■ 31-025172-00	JN621 [195] 50-026033-00 JN622 [196] 50-026032-00	JJ543 (31-026946-00)	HR758 ■ 24-30637-45/0	NB971 ■ 45x67x10mm, FPM (50-305913-50) NB974 ■ 93x114x13mm, FPM (50-319192-00)			 BZ870  JJ543
HBS059 ⊕ (22-26006B) M10x1.50x80mm (x5) M10x1.50x115mm (x6) M10x1.50x102mm (x11)	JD298 ■ 31-025171-30 JD299 ■ 31-025172-00	JN621 50-026033-00 JN622 [199] 50-026032-00	JJ543 (31-026946-00)	HR758 ■ 24-30637-45/0	NB971 ■ 45x67x10mm, FPM (50-305913-50) NB974 ■ 93x114x13mm, FPM (50-319192-00)			 JD161  JD298  JD299  JD475
				HL196 ■ (24-30637-41/0)	NB973 ■ 45x67x8mm, FPM (50-305910-50) NB974 ■ 93x114x13mm, FPM (50-319192-00) PA815 ■ 78x94x8mm (31-019993-30)			 JD476  JD5226
HBS062 ⊕ (22-26074B) M10x1.50x115mm (x5) M10x1.50x102mm (x17)	JD475 ■ (x10) 50-027823-00 JD476 ■	JM5157 (x5) 50-027969-00 JP022 50-027967-00	JJ543 (31-026946-00)	HR804 ■ 24-30704-42/0	NB973 ■ 45x67x8mm, FPM (50-305910-50) NB974 ■ 93x114x13mm, FPM (50-319192-00)			 JD5385  JD5386  JM5157
HBS062 ⊕ (22-26074B) M10x1.50x115mm (x5) M10x1.50x102mm (x17)	JD475 ■ (x10) 50-027823-00 JD476 ■	JM5157 (x5) 50-027969-00 JP022 50-027967-00	JJ543 (31-026946-00)	HR804 ■ 24-30704-42/0	NB971 ■ 45x67x10mm, FPM (50-305913-50) NB974 ■ 93x114x13mm, FPM (50-319192-00)			 JM848
HBS463 (x2) (22-26020B) M11x1.5x141mm (x8)	JD5385 ■ (x2) (31-029992-00) JD5386 ■ (x6) (31-029993-00)	JM5236 ■ (50-029990-00) JM5237 ■ (50-029991-00)			NA5131 ■ 45x67x8mm, PTFE (50-319436-00) NA5168 ■ 93x114x11.5mm, PTFE (50-319437-00)			











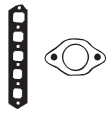

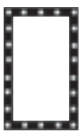

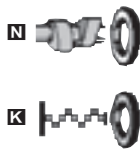

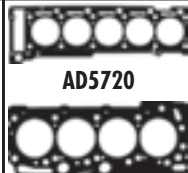

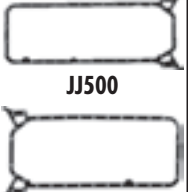
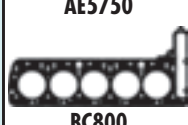
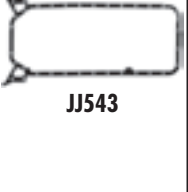

MERCEDES-BENZ

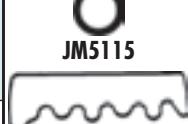

KW/PS

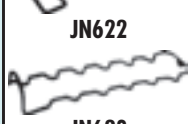

E-Class E 240 (W211)				03/02 →	108	AE5750 (MLS) ☒		
E-Class E 240 T (S211)				03/03 →		30-029988-00		
M 112.913	2398	6	89.90	V6	125/170	AE5760 (MLS) ☒		
M 112.917	2597	6	89.90	V6	130/177	30-029989-00		
E-Class 280 E (W123)				02/76 → 11/85	109			EC821 22-26945-01/0
M 110.923	2746	6	86.00		115/156			
M 110.984/M 110.988	2746	6	86.00	K-Jetronic	136/185			
E-Class Coupe 280 C (C123)				03/77 → 03/80	110			EC821 22-26945-01/0
M 110.923	2746	6	86.00		115/156			
E-Class E 270 CDI (W210) Diesel				07/99 → 03/02	111	AD5720 (MLS), 1.20mm	CD5720 ☒	ED5720 (22-30373-00/0)
E-Class E 270 CDI (W211) Diesel				03/02 →		30-029696-00	21-29696-00/0	
E-Class E 270 T CDI (S210) Diesel				07/99 → 03/03				
E-Class E 270 T CDI (S211) Diesel				03/03 →				
OM 647.961	2685	5	88.00	DOHC	130/177			
OM 612.961	2688	5	88.00	Direct Injection, DOHC	125/170			
E-Class 280 E (W124)				10/92 → 06/93	112	AE5330 (Fibre), 1.24mm	CE5330 ○	21-27354-51/0
E-Class 280 TE (S124)				10/92 → 06/93		30-027354-30		
E-Class E 280 (W124)				06/93 → 06/95				
E-Class E 280 (W210)				01/96 → 06/97				
E-Class E 280 long (W124)				06/93 → 06/95				
E-Class E 280 T (S124)				06/93 → 06/96				
M 104.945	2799	6	89.90		142/193			
M 104.942	2799	6	89.90		142- 145/ 193- 197			
E-Class E 280 (W210)				12/96 → 03/02	113	AE5750 (MLS) ☒		
E-Class E 280 T (S210)				12/96 → 03/03		30-029988-00		
M 112.921	2799	6	89.90	V6	150/204	AE5760 (MLS) ☒		
						30-029989-00		
E-Class 300 D (W123) Diesel				02/76 → 11/85	114	BC800 (Fibre)	DC800	EC791 (22-26944-02/0)
E-Class 300 T D (S123) Diesel				09/77 → 11/85		30-023973-10	21-23973-24/0	
E-Class 300 T Turbo-D (S123) Diesel				10/80 → 11/85				
E-Class 300 Turbo-D (W123) Diesel				08/81 → 07/85				
E-Class Coupe 300 C Turbo-D (C123) Diesel				09/81 → 07/85				
OM 617.912	3005	5	91.00		59-65/ 80-88			
OM 617.952	3005	5	91.00		92/125			
E-Class 300 E (W124)				01/85 → 12/85	115	BN740 (Fibre)	HL657	21-26903-50/0
M 103.980	2962	6	88.50	KE-Jetronic	132/ 140/ 180/ 190	30-026903-00		
E-Class E 290 T Turbo-D (S210) Diesel				06/96 → 07/99	116	BW380 (Fibre), 1.80mm	DW381 ■ ☒ ○	EN720 22-26946-01/0
E-Class E 290 Turbo-D (W210) Diesel				03/96 → 07/99		30-026270-20	21-28404-50/0	
OM 602.982	2874	5	89.00		95/129			

      						 		
HBS463 (x2) [22-26020B] M11x1.5x141mm (x8)	JD5385 (x2) (31-029992-00) JD5386 (x6) (31-029993-00)	JM5236 (x5) (50-029990-00) JM5237 (x6) (50-029991-00)	HR397 [57] 34-000410-00		NA5131 (x2) 45x67x8mm, PTFE (50-319436-00) NA5168 (x6) 93x114x11.5mm, PTFE (50-319437-00)		AE5330 	JJ500 
		PB256 (x5) HL659 (x6) (24-23057-01/0)		HL196 (x5) (24-30637-41/0) →Eng.011014 →Eng.013552 HR754 (x6) (24-24810-02/0) Eng.011015 → Eng.013553 →	NA5264 (x5) (50-305604-00) PA815 (x6) 78x94x8mm (31-019993-30)		AE5750 	JJ543 
		PB256 (x5) HL659 (x6) (24-23057-01/0)		HL196 (x5) (24-30637-41/0) HR754 (x6) (24-24810-02/0)	PA815 (x6) 78x94x8mm (31-019993-30)		BC800 	
HBS293 (x12) (22-26010B) M12x1.75x102mm (x12)	JD5378 (x5) (50-029975-00) JD5798 (x6) 31-030177-00	JM7028 (x5) (50-030203-00) HM5274 (x6) 24-301810-0/0			NA5131 (x12) 45x67x8mm, PTFE (50-319436-00) NA5074 (x3) [3] 93x133.5x15.5mm, PTFE (50-319396-00)		BN740 	
HBS152 (x14) (22-26071B) M12x1.75x160mm (x14)	JD167 (x6) 50-027358-00 JD169 (x2) (31-026443-10)	JM5114 (x6) (50-027355-10) JM5115 (x6) (50-026631-10)	JJ500 (x14) (31-026394-10)	HR5055 (x14) 24-30704-45/0	NB971 (x14) 45x67x10mm, FPM (50-305913-50) NB974 (x14) 93x114x13mm, FPM (50-319192-00)	JR5040 [45] KK5683 [160]	BW380 	
HBS463 (x2) (22-26020B) M11x1.5x141mm (x8)	JD5385 (x2) (31-029992-00) JD5386 (x6) (31-029993-00)	JM5236 (x5) (50-029990-00) JM5237 (x6) (50-029991-00)	HR397 [57] 34-000410-00		NA5131 (x2) 45x67x8mm, PTFE (50-319436-00) NA5168 (x6) 93x114x11.5mm, PTFE (50-319437-00)		JD167 	
HBS046 (x8, x9, x5) (22-26068B) M12x1.75x145mm (x8) M12x1.75x120mm (x9) M12x1.75x105mm (x5)	JD297 (x14) (31-024532-10)	JN273 (x14) (50-023445-20)	JH683 (x14) (31-026944-00)		NB975 (x14) 45x74.5x12mm, FPM (50-306557-50) PA815 (x6) 78x94x8mm (31-019993-30)		JD298 	
HBS146 (x14) (22-26004B) M12x1.75x102mm (x14)		JN623 (x14) 50-025260-10	JJ491 (x14) (31-026841-00)	HR759 (x14) 24-30615-74/0	NC065 (x14) 30x40x7mm, FPM (50-306142-00) NB971 (x14) 45x67x10mm, FPM (50-305913-50) NB974 (x14) 93x114x13mm, FPM (50-319192-00)	KK5683 [160]	JD299 	
HBS059 (x5, x6, x11) (22-26006B) M10x1.50x80mm (x5) M10x1.50x115mm (x6) M10x1.50x102mm (x11)	JD298 (x11) 31-025171-30 JD299 (x6) 31-025172-00	JN621 [195] 50-026033-00 JN622 [196] 50-026032-00	JJ543 (x11) (31-026946-00)	HR758 (x11) 24-30637-45/0	NB973 (x11) 45x67x8mm, FPM (50-305910-50) NB974 (x6) 93x114x13mm, FPM (50-319192-00)		JD5378 	
							JD5385 	
							JD5386 	
							JM5114 	
							JM5115 	
							JN273 	
							JN621 	
							JN622 	
							JN623 	

MERCEDES-BENZ



KW/PS



E-Class E 280 CDI (W211) Diesel 03/05 → 117						AH5010 (MLS) ☒ 30-030364-00 AH5020 (MLS) ☒ 30-030363-00		
E-Class E 280 CDI 4-matic (W211) Diesel 03/05 →								
E-Class E 280 T CDI (S211) Diesel 03/05 →								
E-Class E 280 T CDI 4-matic (S211) Diesel 03/05 →								
E-Class E 300 (W211) Diesel 09/07 →								
E-Class E 320 CDI (W211) Diesel 03/05 →								
E-Class E 320 T CDI (S211) Diesel 03/05 →								
E-Class E 320 T CDI 4-matic (S211) Diesel 03/05 →								
OM 642.921	2987	6	83.00	Direct Injection, V6	140/190			
OM 642.920	2987	6	83.00	Direct Injection, V6	140-165/190-224			
E-Class E 320 CDI 4-matic (W211) Diesel 03/05 → 118						AH5010 (MLS) ☒ 30-030364-00 AH5020 (MLS) ☒ 30-030363-00	CH5010 21-30364-00/0	
OM 642.910	2987	6	83.00	Direct Injection	165/224			
E-Class 300 D (W124) Diesel 12/84 → 06/93 119						BT550 (Fibre) 30-027114-20		
E-Class 300 T D (S124) Diesel 09/86 → 06/93								
E-Class 300 Turbo-D (W124) Diesel 01/88 → 06/93								
OM 603.912/OM 603.913	2996	6	87.00		80/83/109/113			
OM 603.963	2996	6	87.00		105-108/143-147			
E-Class 300 E (W124) 06/85 → 08/92 120						BN740 (Fibre) 30-026903-00	HL657 21-26903-50/0	
E-Class Coupe 300 CE (C124) 03/87 → 05/93								
E-Class E 300 (W124) 06/93 → 06/95								
E-Class E 300 T (S124) 06/93 → 06/96								
M 103.983/M 103.985	2962	6	88.50	KE-Jetronic	132/140/180/190			
E-Class 300 E (W124) 09/86 → 06/93 121						BN740 (Fibre) 30-026903-00	HL657 21-26903-50/0	
M 103.985	2962	6	88.50	KE-Jetronic	132/140/180/190			
E-Class 300 E 4-Matic Diesel 09/86 → 01/89 122						BT550 (Fibre) 30-027114-20		
OM 603.960/OM 603.963	2996	6	87.00	Turbo	105-108/143-147			
E-Class 300 E-24 (W124) 09/88 → 08/92 123						AC5520 (Fibre) 30-027091-10 AE5330 (Fibre), 1.24mm 30-027354-30	CC5520 21-27091-20/0	
E-Class 300 TE-24 (S124) 09/89 → 08/92								
E-Class Coupe 300 CE-24 (C124) 09/89 → 12/92								
M 104.980	2960	6	88.50	DOHC	162/170/220/231			

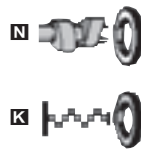
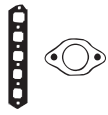

AC5520



AE5330



BN740



BT550



JD301

JM5115



JN623



JN851



JN852

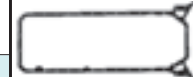

JJ500

HBS474 Ⓢ (22-26025B) M12x1.75x205mm (x16)	JD5902 Ⓢ (x2) 31-030365-00 (MLS)	HR397 [57] 34-000410-00	HR397 [57] 34-000410-00		NA5131 Ⓢ 45x67x8mm, PTFE (50-319436-00)	
HBS474 Ⓢ (22-26025B) M12x1.75x205mm (x16)	JD5902 Ⓢ (x2) 31-030365-00 (MLS) JE5067 Ⓢ (31-030360-00) JE5068 Ⓢ (31-030361-00)	HR397 [57] 34-000410-00	HR397 [57] 34-000410-00		NA5131 Ⓢ 45x67x8mm, PTFE (50-319436-00)	
HBS060 Ⓢ (22-26007B) M10x1.50x80mm (x6) M10x1.50x115mm (x7) M10x1.50x102mm (x13)	JD301 Ⓢ (31-025174-00)	JN851 [196] (50-026034-10) JN852 [195] (50-026035-00)	JJ500 (31-026394-10)	HR760 Ⓢ 24-30672-70/0	NB971 Ⓢ 45x67x10mm, FPM (50-305913-50) NB974 Ⓢ 93x114x13mm, FPM (50-319192-00)	
HBS146 Ⓢ (22-26004B) M12x1.75x102mm (x14)		JN623 50-025260-10	JJ491 (31-026841-00)	HR759 Ⓢ 24-30615-74/0	NC065 30x40x7mm, FPM (50-306142-00) NB971 Ⓢ 45x67x10mm, FPM (50-305913-50) NB974 Ⓢ 93x114x13mm, FPM (50-319192-00)	KK5683 [160]
HBS146 Ⓢ (22-26004B) M12x1.75x102mm (x14)		JN623 50-025260-10	JJ491 (31-026841-00)	HR759 Ⓢ 24-30615-74/0	NC065 30x40x7mm, FPM (50-306142-00) NB971 Ⓢ 45x67x10mm, FPM (50-305913-50) NB974 Ⓢ 93x114x13mm, FPM (50-319192-00)	KK5683 [160]
HBS060 Ⓢ (22-26007B) M10x1.50x80mm (x6) M10x1.50x115mm (x7) M10x1.50x102mm (x13)	JD301 Ⓢ (31-025174-00)	JN851 (50-026034-10) JN852 (50-026035-00)	JJ500 (31-026394-10)	HR760 Ⓢ 24-30672-70/0	NB973 Ⓢ 45x67x8mm, FPM (50-305910-50) NB974 Ⓢ 93x114x13mm, FPM (50-319192-00)	
HBS152 Ⓢ (22-26071B) M12x1.75x160mm (x14)	JD169 Ⓢ (31-026443-10)	JM5113 (50-026630-00) JM5115 (x6) (50-026631-10)	JJ500 (31-026394-10)	HR5055 Ⓢ 24-30704-45/0	NB971 Ⓢ 45x67x10mm, FPM (50-305913-50) NB974 Ⓢ 93x114x13mm, FPM (50-319192-00)	JR5040 [45] KK5683 [160]











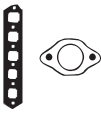

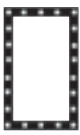

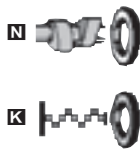





MERCEDES-BENZ



KW/PS



E-Class 300 T D (S124) Diesel 01/89 → 06/93 124				BT550 (Fibre) 30-027114-20			
E-Class 300 T Turbo-D (S124) Diesel 09/86 → 06/93							
E-Class 300 Turbo-D (W124) Diesel 09/86 → 06/93							
E-Class E 300 T Turbo-D (S124) Diesel 06/93 → 06/96							
E-Class E 300 Turbo-D (W124) Diesel 06/93 → 06/95							
OM 603.912	2996	6	87.00		80/83/ 109/ 113		
OM 603.960/OM 603.963	2996	6	87.00		105- 108/ 143- 147		
E-Class 300 TE (S124) 01/86 → 06/93 125				BN740 (Fibre) 30-026903-00		HL657 21-26903-50/0	
M 103.983/M 103.985	2962	6	88.50	KE-Jetronic	132/ 140/ 180/ 190		
E-Class Convertible 300 CE-24 (A124) 04/92 → 06/93 126				AC5520 (Fibre) 30-027091-10		CC5520 21-27091-20/0	
E-Class E 300 TE-24 AMG (S124) 06/93 → 06/96				AE5330 (Fibre), 1.24mm 30-027354-30			
M 104.980	2960	6	88.50	DOHC	162/ 170/ 220/ 231		
E-Class E 300 D (W124) Diesel 07/93 → 06/95 127				BY580 (Fibre) 30-027831-00		DY580 21-27831-50/0	EY580 (22-26394-50/0)
E-Class E 300 D (W210) Diesel 06/95 → 06/97							
E-Class E 300 T D (S124) Diesel 06/93 → 06/96							
OM 606.912	2996	6	87.00	DOHC	100/136		
OM 606.910	2996	6	87.00	DOHC	130/177		
E-Class E 300 T Turbo-D (S124) Diesel 06/93 → 06/96 128				BT550 (Fibre) 30-027114-20			
E-Class E 300 Turbo-D (W124) Diesel 06/93 → 06/95							
OM 603.963	2996	6	87.00		105- 108/ 143- 147		
E-Class E 300 T Turbo-D (S210) Diesel 12/96 → 07/99 129				BY580 (Fibre) 30-027831-00			EY580 (22-26394-50/0)
E-Class E 300 Turbo-D (W210) Diesel 12/96 → 07/99							
OM 606.962	2996	6	87.00	DOHC	130/177		
E-Class 320 E (W124) 10/92 → 06/93 130				AE5330 (Fibre), 1.24mm 30-027354-30		CE5330 21-27354-51/0	
E-Class 320 TE (S124) 10/92 → 06/93							
E-Class Convertible E 320 (A124) 06/93 → 03/98							
E-Class Coupe 320 CE (C124) 10/92 → 05/93							
E-Class Coupe E 320 (C124) 06/93 → 06/97							
E-Class E 320 (W124) 06/93 → 06/95							
E-Class E 320 T (S124) 06/93 → 06/96							
M 104.992/M 104.995	3199	6	89.90		162/220		

								
HBS060 Ⓢ (22-26007B) M10x1.50x80mm (x6) M10x1.50x115mm (x7) M10x1.50x102mm (x13)	JD301 ■ (31-025174-00)	JN851 [196] (50-026034-10) JN852 [195] (50-026035-00)	JJ500 (31-026394-10)	HR760 ■ 24-30672-70/0	NB971 ■ 45x67x10mm, FPM (50-305913-50) NB974 ■ 93x114x13mm, FPM (50-319192-00)			 AC5520  AE5330  BN740  BT550  BY580  JD167  JD301  JM5114  JM5115  JM5157  JN623  JN851  JN852  JJ500
HBS146 Ⓢ (22-26004B) M12x1.75x102mm (x14)		JN623 50-025260-10	JJ491 (31-026841-00)	HR759 ■ 24-30615-74/0	NC065 30x40x7mm, FPM (50-306142-00) NB975 ■ 45x74.5x12mm, FPM (50-306557-50) NB974 ■ 93x114x13mm, FPM (50-319192-00)		KK5683 [160]	
HBS152 Ⓢ (22-26071B) M12x1.75x160mm (x14)	JD169 ■ (x2) (31-026443-10)	JM5113 (50-026630-00) JM5115 (x6) (50-026631-10)	JJ500 (31-026394-10)	HR5055 ■ 24-30704-45/0	NB971 ■ 45x67x10mm, FPM (50-305913-50) NB974 ■ 93x114x13mm, FPM (50-319192-00)		JR5040 [45] KK5683 [160]	
HBS063 Ⓢ (22-26075B) M10x1.50x102mm (x20) M10x1.50x115mm (x6)	JD478 ■ (31-027826-00)	JM5157 50-027969-00	JJ500 (31-026394-10)	HR5057 ■ (24-30704-43/0)	NB973 ■ 45x67x8mm, FPM (50-305910-50) NB974 ■ 93x114x13mm, FPM (50-319192-00)			
HBS060 Ⓢ (22-26007B) M10x1.50x80mm (x6) M10x1.50x115mm (x7) M10x1.50x102mm (x13)	JD301 ■ (31-025174-00)	JN851 [196] (50-026034-10) JN852 [195] (50-026035-00)	JJ500 (31-026394-10)	HR760 ■ 24-30672-70/0	NB973 ■ 45x67x8mm, FPM (50-305910-50) NB974 ■ 93x114x13mm, FPM (50-319192-00)			
HBS063 Ⓢ (22-26075B) M10x1.50x102mm (x20) M10x1.50x115mm (x6)		JM5157 50-027969-00	JJ500 (31-026394-10)	HR5057 ■ (24-30704-43/0)	NB973 ■ 45x67x8mm, FPM (50-305910-50) NB974 ■ 93x114x13mm, FPM (50-319192-00)			
HBS152 Ⓢ (22-26071B) M12x1.75x160mm (x14)	JD167 ■ (x6) 50-027358-00 JD169 ■ (x2) (31-026443-10)	JM5114 (50-027355-10) JM5115 (x6) (50-026631-10)	JJ500 (31-026394-10)	HR5055 ■ 24-30704-45/0	NB971 ■ 45x67x10mm, FPM (50-305913-50) NB974 ■ 93x114x13mm, FPM (50-319192-00)		JR5040 [45] KK5683 [160]	











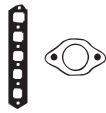

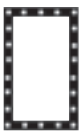

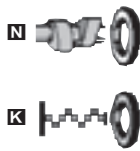















MERCEDES-BENZ



KW/PS



E-Class E 280 CDI (W211) Diesel		05/04 →		131		AG8490 (MLS)			
E-Class E 280 T CDI (S211) Diesel		05/04 →				(30-030198-00)			
E-Class E 320 CDI (W211) Diesel		11/02 →							
E-Class E 320 T CDI (S211) Diesel		03/03 →							
OM 648.961	3222	6	88.00	Direct Injection, DOHC		130-150/177-204			
E-Class E 320 (W210)		06/95 →06/97		132		AE5330 (Fibre), 1.24mm		CE5330 ○	
M 104.992	3199	6	89.90			162/220	30-027354-30	21-27354-51/0	
E-Class E 320 (W210)		06/97 →03/02		133		AE5750 (MLS) ☒			
E-Class E 320 (W211)		03/03 →				30-029988-00			
E-Class E 320 T (S210)		12/96 →03/03				AE5760 (MLS) ☒			
E-Class E 320 T (S211)		03/03 →				30-029989-00			
M 112.941/M 112.949	3199	6	89.90	V6		165/224			
M 112.954	3199	6	89.90	Injection, V6		165/224			
E-Class E 320 (W211)		03/02 →		134		AE5750 (MLS) ☒			
M 112.949	3199	6	89.90	V6		165/224	30-029988-00 AE5760 (MLS) ☒ 30-029989-00		
E-Class E 320 CDI (W210) Diesel		07/99 →03/02		135		AG8490 (MLS)			
E-Class E 320 T CDI (S210) Diesel		07/99 →03/03				(30-030198-00)			
OM 613.961	3226	6	88.00	Direct Injection, DOHC		145/197			
E-Class E 350 (W211)		03/05 →		136		AG8380 (MLS), 0.65mm ☒			
E-Class E 350 T (S211)		03/05 →				(30-029487-00)			
M 272.964/M 272.972	3498	6	92.90	Injection, DOHC, V6		200/272	→Eng.30089232 AG8370 (MLS), 0.65mm ☒ (30-029486-00) →Eng.30089232 AG8420 (MLS), 0.65mm ☒ (30-030052-00) Eng.30089233 → AG8410 (MLS), 0.65mm ☒ (30-030051-00) Eng.30089233 →		
E-Class E 350 4-matic (W211)		03/05 →		137		AG8420 (MLS), 0.65mm ☒			
E-Class E 350 T 4-matic (S211)		03/05 →				(30-030052-00)			
M 272.964/M 272.972	3498	6	92.90	Injection, DOHC, V6		200/272	AG8410 (MLS), 0.65mm ☒ (30-030051-00)		
E-Class Convertible E 36 AMG (A124)		05/94 →03/98		138		AE5330 (Fibre), 1.24mm		CE5330 ○	
E-Class Coupe E 36 AMG (C124)		06/93 →06/97				30-027354-30		21-27354-51/0	
E-Class E 36 T AMG (S124)		05/94 →06/96							
M 104.992 (AMG 3.6)	3606	6	91.00	Injection, DOHC		195-200/265-272			
E-Class 400 E (W124)		10/92 →06/93		139		AC5530 (Fibre) ☒			
E-Class E 420 (W124)		06/93 →06/95				30-027156-00			
M 119.975	4196	8	92.00	DOHC, V8		205/279			

								
HBS294 Ⓢ (22-26014B) M12x1.75x102mm (x14)	JE5032 Ⓢ (31-029697-00) (MLS)			HR5055 Ⓢ 24-30704-45/0	NA5131 Ⓢ 45x67x8mm, PTFE (50-319436-00) NA5074 Ⓢ [3] 93x133.5x15.5mm, PTFE (50-319396-00)			 AC5530  AE5330  AE5750  AG8370  AG8380
HBS152 Ⓢ (22-26071B) M12x1.75x160mm (x14)	JD167 Ⓢ (x6) 50-027358-00 JD169 Ⓢ (x2) (31-026443-10)	JM5114 (50-027355-10) JM5115 (x6) (50-026631-10)	JJ500 (31-026394-10)	HR5055 Ⓢ 24-30704-45/0	NB971 Ⓢ 45x67x10mm, FPM (50-305913-50) NB974 Ⓢ 93x114x13mm, FPM (50-319192-00)		JR5040 [45] KK5683 [160]	 AG8370  AG8380  JD167  JD5385  JD5386
HBS463 (x2) (22-26020B) M11x1.5x141mm (x8)	JD5385 Ⓢ (x2) (31-029992-00) JD5386 Ⓢ (x6) (31-029993-00)	JM5236 Ⓢ (50-029990-00) JM5237 Ⓢ (50-029991-00)	HR397 [57] 34-000410-00		NA5131 Ⓢ 45x67x8mm, PTFE (50-319436-00) NA5168 Ⓢ 93x114x11.5mm, PTFE (50-319437-00)			 AG8380  JD167  JD5385  JD5386
HBS463 (x2) (22-26020B) M11x1.5x141mm (x8)	JD5385 Ⓢ (x2) (31-029992-00) JD5386 Ⓢ (x6) (31-029993-00)	JM5236 Ⓢ (50-029990-00) JM5237 Ⓢ (50-029991-00)	HR397 [57] 34-000410-00		NA5131 Ⓢ 45x67x8mm, PTFE (50-319436-00) NA5168 Ⓢ 93x114x11.5mm, PTFE (50-319437-00)			 JE5032  JM5114  JM5115
HBS294 Ⓢ (22-26014B) M12x1.75x102mm (x14)	JE5032 Ⓢ (31-029697-00) (MLS)			HR5055 Ⓢ 24-30704-45/0	NA5131 Ⓢ 45x67x8mm, PTFE (50-319436-00)			 JM5114  JM5115
		HR397 [57] 34-000410-00	HR397 [57] 34-000410-00	HR280 Ⓢ (x2) 24-30614-75/0	NA5131 Ⓢ 45x67x8mm, PTFE (50-319436-00)		NA5248 [2]Ⓢ  NA5248	 JM5114  JM5115
		HR397 [57] 34-000410-00	HR397 [57] 34-000410-00	HR280 Ⓢ (x2) 24-30614-75/0	NA5131 Ⓢ 45x67x8mm, PTFE (50-319436-00)		NA5248 [2]Ⓢ  NA5248	 JJ500
HBS152 Ⓢ (22-26071B) M12x1.75x160mm (x14)	JD167 Ⓢ (x6) 50-027358-00 JD169 Ⓢ (x2) (31-026443-10)	JM5114 (50-027355-10) JM5115 (x6) (50-026631-10)	JJ500 (31-026394-10)	HR5055 Ⓢ 24-30704-45/0	NB971 Ⓢ 45x67x10mm, FPM (50-305913-50) NB974 Ⓢ 93x114x13mm, FPM (50-319192-00)		JR5040 [45] KK5683 [160]	
			JH5113 (31-026467-10)		NB973 Ⓢ 45x67x8mm, FPM (50-305910-50) NA5268 Ⓢ 100x124x13mm, FPM (50-306799-50)			











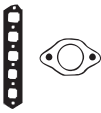

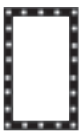













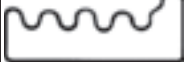

MERCEDES-BENZ



KW/PS

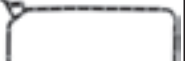

G-Class 230 GE (W460)				05/87 → 08/92	140	BH880 (Fibre)		EH872 22-26812-04/0 M 102.979 EH881 Eng.102.987-000258 → Eng.102.987-000742 →
M 102.979	2299	4	95.50	K-Jetronic	90/122	30-026005-10		
M 102.987	2299	4	95.50	K-Jetronic	90/92/ 122- 125			
G-Class 230 GE (W460)				04/82 → 08/92	141	BH880 (Fibre)		EH881 Eng.102.987-000258 → Eng.102.987-000742 →
M 102.987	2299	4	95.50	K-Jetronic	90/92/ 122- 125	30-026005-10		
M 102.981	2299	4	95.50	K-Jetronic	92/125			
G-Class 230 GE (W461)				06/93 →	142	BH880 (Fibre)		EH881
G-Class 230 GE (W463)				06/90 → 06/93		30-026005-10		
M 102.996	2299	4	95.50	K-Jetronic	92/125			
M 102.997	2299	4	95.50	Injection, SOHC	92/125			
M 102.989	2299	4	95.50	K-Jetronic	93/126			
G-Class 230 GE (W461)				02/93 →	143	BH880 (Fibre)		EH872 22-26812-04/0
M 102.979	2299	4	95.50	K-Jetronic	90/122	30-026005-10		
G-Class 240 GD (W460) Diesel				03/79 → 08/87	144	BC790 (Fibre)	DC790 ■ 21-24065-24/0	EC790 (22-26944-01/0) GC790 20-24065-01/0
OM 616.936	2399	4	90.90		53/72	30-024065-10		
G-Class 250 GD (W460) Diesel				10/87 → 12/92	145	BN720 (Fibre), 1.74mm	DN722 ■ [195] 21-27216-51/0	EN720 22-26946-01/0
G-Class 250 GD (W461) Diesel				02/90 →		30-027216-20	DN723 ■ [196]	
G-Class 250 GD (W463) Diesel				06/90 →				
OM 602.930	2497	5	87.00		62-69/ 84-94			
OM 602.939	2497	5	87.00		68/92			
OM 602.931	2497	5	87.00	SOHC	69/93			
G-Class G 270 CDI (W463) Diesel				10/01 →	146	AD5720 (MLS), 1.20mm	CD5720 ☒ 21-29696-00/0	ED5720 (22-30373-00/0)
OM 612.966	2685	5	88.00	Direct Injection, DOHC	115/156	30-029696-00		
G-Class 290 GD/G 290 D (W461) Diesel				04/92 →	147	BW380 (Fibre), 1.80mm	DW381 ■ ☒ ○ 21-28404-50/0	EN720 22-26946-01/0
G-Class G 290 TD (W461) Diesel				07/97 →		30-026270-20		
OM 602.942	2874	5	89.00		70-72/ 95-98			
OM 602.983	2874	5	89.00		88/120			
G-Class G 320 CDI (W463) Diesel				09/06 →	148	AH5010 (MLS) ☒		
G-Class GL 320 CDI (X164) Diesel				09/06 →		30-030364-00		
OM 642.822/OM 642.970	2987	6	83.00	Direct Injection, DOHC, V6	165/224	AH5020 (MLS) ☒ 30-030363-00		
G-Class 300 GD (W460) Diesel				03/79 → 07/93	149	BT550 (Fibre)		
G-Class 300 GD (W463) Diesel				09/89 → 09/97		30-027114-20		
OM 603.912/OM 603.931	2996	6	87.00		80/83/ 109/ 113			
G-Class 300 GD (W460) Diesel				12/79 → 12/91	150	BC800 (Fibre)	DC800 21-23973-24/0	EC791 (22-26944-02/0)
OM 617.931	3005	5	90.90		65/88	30-023973-10		

								
HBS047 Ⓢ (22-26065B) M12x1.75x120mm (x10)	JD182 ■ 31-026877-00 JD292 ■ (x4) 31-026634-10	JN454 [195] 50-024959-10 JN607 [196] 50-025120-10		HR756 ■ 24-30615-70/0	NB973 ■ 45x67x8mm, FPM (50-305910-50) NB974 ■ 93x114x13mm, FPM (50-319192-00)			 AD5720  BC790  BC800  BH880  BN720  BT550  BW380  JD182  JD292  JD298  JD299  JD301  JD5378  JM848  JN273  JN454  JN607  JN621  JN622
HBS047 Ⓢ (22-26065B) M12x1.75x120mm (x10)	JD182 ■ 31-026877-00 JD292 ■ (x4) 31-026634-10	JN454 [195] 50-024959-10 JN607 [196] 50-025120-10		HR756 ■ 24-30615-70/0	NB973 ■ 45x67x8mm, FPM (50-305910-50) NB974 ■ 93x114x13mm, FPM (50-319192-00)			 JN851  JN852  JH683  JJ500  JJ543
HBS047 Ⓢ (22-26065B) M12x1.75x120mm (x10)	JD182 ■ 31-026877-00	JN454 [195] 50-024959-10 JN607 [196] 50-025120-10		HR756 ■ 24-30615-70/0	NB973 ■ 45x67x8mm, FPM (50-305910-50) NB974 ■ 93x114x13mm, FPM (50-319192-00)			
HBS047 Ⓢ (22-26065B) M12x1.75x120mm (x10)	JD182 ■ 31-026877-00 JD292 ■ (x4) 31-026634-10	JN607 50-025120-10		HR756 ■ 24-30615-70/0	NB973 ■ 45x67x8mm, FPM (50-305910-50) NB974 ■ 93x114x13mm, FPM (50-319192-00)			
HBS045 Ⓢ (22-26067B) M12x1.75x105mm (x4) M12x1.75x145mm (x6) M12x1.75x120mm (x8)	JB162 (31-024970-20)	JM848 50-022825-00	JH683 (31-026944-00)		NB975 ■ 45x74.5x12mm, FPM (50-306557-50) PA815 ■ 78x94x8mm (31-019993-30)			
HBS059 Ⓢ (22-26006B) M10x1.50x80mm (x5) M10x1.50x115mm (x6) M10x1.50x102mm (x11)	JD298 ■ 31-025171-30 JD299 ■ 31-025172-00	JN621 [195] 50-026033-00 JN622 [196] 50-026032-00	JJ543 (31-026946-00)	HR758 ■ 24-30637-45/0	NB973 ■ 45x67x8mm, FPM (50-305910-50) NB974 ■ 93x114x13mm, FPM (50-319192-00) NA5074 ■ [3] 93x133.5x15.5mm, PTFE (50-319396-00)			
HBS293 Ⓢ (22-26010B) M12x1.75x102mm (x12)	JD5378 ■ (x5) (50-029975-00) JD5798 ■ 31-030177-00	JM7028 (50-030203-00) HM5274 ■ 24-30181-00/0			NA5131 ■ 45x67x8mm, PTFE (50-319436-00) NA5074 ■ [3] 93x133.5x15.5mm, PTFE (50-319396-00)			
HBS059 Ⓢ (22-26006B) M10x1.50x80mm (x5) M10x1.50x115mm (x6) M10x1.50x102mm (x11)	JD298 ■ 31-025171-30 JD299 ■ 31-025172-00	JN621 50-026033-00	JJ543 (31-026946-00)	HR758 ■ 24-30637-45/0	NB973 ■ 45x67x8mm, FPM (50-305910-50) NB974 ■ 93x114x13mm, FPM (50-319192-00)			
HBS474 Ⓢ (22-26025B) M12x1.75x205mm (x16)								
HBS060 Ⓢ (22-26007B) M10x1.50x80mm (x6) M10x1.50x115mm (x7) M10x1.50x102mm (x13)	JD301 ■ (31-025174-00)	JN851 [196] (50-026034-10) JN852 [195] (50-026035-00)	JJ500 (31-026394-10)	HR760 ■ 24-30672-70/0	NB971 ■ 45x67x10mm, FPM (50-305913-50) NB974 ■ 93x114x13mm, FPM (50-319192-00)			
HBS046 Ⓢ (22-26068B) M12x1.75x145mm (x8) M12x1.75x120mm (x9) M12x1.75x105mm (x5)	JD297 ■ (31-024532-10)	JN273 (50-023445-20)	JH683 (31-026944-00)		NB975 ■ 45x74.5x12mm, FPM (50-306557-50) PA815 ■ 78x94x8mm (31-019993-30)			











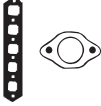

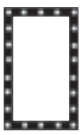

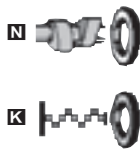











MERCEDES-BENZ

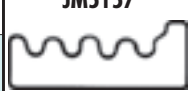

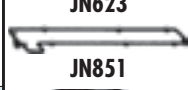
KW/PS



G-Class 300 GE (W463)				09/89 → 09/97	151	BN740 (Fibre) 30-026903-00	HL657 21-26903-50/0	
M 103.987	2962	6	88.50	KE-Jetronic	132/ 140/ 180/ 190			
G-Class G 300 TD (W463) Diesel				08/96 →	152	BY580 (Fibre) 30-027831-00		EY580 (22-26394-50/0)
OM 606.964	2996	6	87.00	DOHC	130/177			
G-Class 320 GE (W463)				09/94 → 11/97	153	AE5330 (Fibre), 1.24mm 30-027354-30	CE5330 ○ 21-27354-51/0	
G-Class G 320 (W463)				09/94 → 12/97				
M 104.996	3199	6	89.90		155/211			
G-Class G 320 (W463)				07/97 →	154	AE5750 (MLS) ☒ 30-029988-00 AE5760 (MLS) ☒ 30-029989-00		
M 112.945	3199	6	89.90	V6	158/215			
G-Class 350 G Turbo D (W463) Diesel				09/91 →	155			
G-Class 350 G Turbo-D (W463) Diesel				09/91 → 09/97				
OM 603.972	3449	6	89.00		100/136			
G-Class G 36 AMG (W463)				01/95 →	156	AE5330 (Fibre), 1.24mm 30-027354-30	CE5330 ○ 21-27354-51/0	
	3606	6			200/272			
G-Class G 400 CDI (W463) Diesel				12/00 →	157			
OM 628.962	3996	8	86.00	Direct Injection, DOHC, V8	184/250			
G-Class GL 450 (X164)				09/06 →	158	AG8470 (MLS) ☒ (30-029951-00) AG8480 (MLS) ☒ (30-029952-00)		
M 273.923	4663	8	92.90	Injection, DOHC, V8	250/340			
G-Class G 500 (W463)				04/98 →	159			
M 113.962	4966	8	97.00	DOHC, V8	220/299			
G-Class G 55 AMG (W463)				06/04 →	160			
M 113.993	5439	8	97.00	Injection, V8	350/476			
G-Class GL 500 (X164)				09/06 →	161	AG8440 (MLS) ☒ (30-029954-00) AG8430 (MLS) ☒ (30-029953-00)		
M 273.963	5461	8	98.00	Injection, DOHC, V8	285/388			
G-Class G 55 AMG (W463)				04/99 →	162			
M 113.982	5439	8	97.00	Injection, V8	260/354			
GLK-Class 320 CDI 4-matic (X204) Diesel				06/08 →	163	AH5010 (MLS) ☒ 30-030364-00 AH5020 (MLS) ☒ 30-030363-00		
OM 642.961	2987	6	83.00	Direct Injection, DOHC, V6	165/224			
Henschel 2-T 206 D 2.2L Diesel				02/73 → 12/77	164	BG990 (Fibre) 30-023924-10		
OM 615.917/ OM 615.937/OM 615.939	2197	4	87.00		44/60			

								
HBS146 Ⓞ [22-26004B] M12x1.75x102mm (x14)			JN623 50-025260-10	JJ491 [31-026841-00]		NA973 45x67x8mm, FPM (50-305910-50) NA974 93x114x13mm, FPM (50-319192-00)	KK5683 [160]	
HBS063 Ⓞ [22-26075B] M10x1.50x102mm (x20) M10x1.50x115mm (x6)			JM5157 50-027969-00	JJ500 [31-026394-10]	HR5057 [24-30704-43/0]	NA973 45x67x8mm, FPM (50-305910-50) NA974 93x114x13mm, FPM (50-319192-00)		
HBS152 Ⓞ [22-26071B] M12x1.75x160mm (x14)	JD167 [x6] 50-027358-00 JD169 [x2] [31-026443-10]	JM5114 [50-027355-10]	JJ500 [31-026394-10]	HR5055 24-30704-45/0	NA975 45x74.5x12mm, FPM (50-306557-50) NA974 93x114x13mm, FPM (50-319192-00)	JR5040 [45] KK5683 [160]		
HBS463 (x2) [22-26020B] M11x1.5x141mm (x8)	JD5385 [x2] [31-029992-00] JD5386 [x6] [31-029993-00]	JM5236 [50-029990-00] JM5237 [50-029991-00]	HR397 [57] 34-000410-00		NA5131 45x67x8mm, PTFE (50-319436-00) NA5168 93x114x11.5mm, PTFE (50-319437-00)			
HBS060 Ⓞ [22-26007B] M10x1.50x80mm (x6) M10x1.50x115mm (x7) M10x1.50x102mm (x13)	JD301 [31-025174-00]	JN851 [50-026034-10]	JJ500 [31-026394-10]	HR760 24-30672-70/0	NA973 45x67x8mm, FPM (50-305910-50) NA974 93x114x13mm, FPM (50-319192-00)			
HBS152 Ⓞ [22-26071B] M12x1.75x160mm (x14)	JD167 50-027358-00 JD169 [x2] [31-026443-10]	JM5114 [50-027355-10] JM5115 [x6] [50-026631-10]	JJ500 [31-026394-10]	HR5055 24-30704-45/0	NA971 45x67x10mm, FPM (50-305913-50) NA974 93x114x13mm, FPM (50-319192-00)			
	JD5380 [x2] [31-029977-00] (MLS)		HR397 [57] 34-000410-00	HR5085 [x8] 34-000410-00	NA5131 45x67x8mm, PTFE (50-319436-00) NA5168 93x114x11.5mm, PTFE (50-319437-00)			
		HR397 [57] 34-000410-00	HR397 [57] 34-000410-00	HR791 [x2] 24-30614-76/0	NA5131 45x67x8mm, PTFE (50-319436-00)			
	JD5386 [x8] [31-029993-00]		HR397 [57] 34-000410-00	HR5055 24-30704-45/0	NA5131 45x67x8mm, PTFE (50-319436-00) NA5168 93x114x11.5mm, PTFE (50-319437-00)			
	JD5386 [x8] [31-029993-00]		HR397 [57] 34-000410-00	HR5055 24-30704-45/0	NA5131 45x67x8mm, PTFE (50-319436-00) NA5168 93x114x11.5mm, PTFE (50-319437-00)			
		HR397 [57] 34-000410-00	HR397 [57] 34-000410-00	HR791 [x2] 24-30614-76/0	NA5131 45x67x8mm, PTFE (50-319436-00)			
	JD5386 [x8] [31-029993-00]		HR397 [57] 34-000410-00	HR5055 24-30704-45/0	NA5131 45x67x8mm, PTFE (50-319436-00) NA5168 93x114x11.5mm, PTFE (50-319437-00)			
HBS474 Ⓞ [22-26025B] M12x1.75x205mm (x16)					NA5131 45x67x8mm, PTFE (50-319436-00) NA5168 93x114x11.5mm, PTFE (50-319437-00)			
HBS045 Ⓞ [22-26067B] M12x1.75x105mm (x4) M12x1.75x145mm (x6) M12x1.75x120mm (x8)	JB162 [31-024970-20]	JM848 50-022825-00	JH683 [31-026944-00]					
								
								
								
								
								







MERCEDES-BENZ

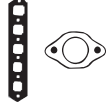

KW/PS

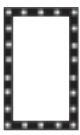

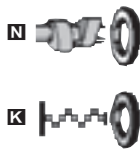
M-Class ML 230 (W163)				02/98 → 06/05	165	BZ900 (Fibre) 30-027971-00	DZ900 21-27971-51/0	EV810 22-27311-50/0
M 111.977	2295	4	90.90	Injection, DOHC	110/150			
M-Class ML 270 CDI (W163) Diesel				12/99 → 06/05	166	AD5720 (MLS), 1.20mm 30-029696-00	CD5720 21-29696-00/0	ED5720 (22-30373-00/0)
OM 612.963	2685	5	88.00	Direct Injection, DOHC	120/163			
M-Class ML 280 CDI 4-matic (W164) Diesel				07/05 →	167	AH5010 (MLS) 30-030364-00	CH5010 21-30364-00/0	
M-Class ML 320 CDI 4-matic (W164) Diesel				07/05 →		AH5020 (MLS) 30-030363-00		
OM 642.940	2987	6	83.00	Direct Injection, V6	140- 165/ 190- 224			
M-Class ML 320 (W163)				02/98 → 08/02	168	AE5750 (MLS) 30-029988-00		
M 112.942	3199	6	89.90	V6	160/218	AE5760 (MLS) 30-029989-00		
M-Class ML 350 4-matic (W164)				07/05 →	169	AG8380 (MLS), 0.65mm (30-029487-00) → Eng.30089232		
M 272.962	3498	6	92.90	Injection, V6	200/272	AG8370 (MLS), 0.65mm (30-029486-00) → Eng.30089232		
M 272.967	3498	6	92.90	Injection, DOHC, V6	200/272	AG8420 (MLS), 0.65mm (30-030052-00) Eng.30089233 →		
						AG8410 (MLS), 0.65mm (30-030051-00) Eng.30089233 →		
M-Class ML 350 (W163)				08/02 → 06/05	170			
M 112.970	3724	6	97.00	Injection, V6	173- 180/ 235- 245			
O 100 City Diesel				01/94 →	171	BW380 (Fibre), 1.80mm 30-026270-20	DW380 21-26270-52/0	EN720 22-26946-01/0
OM 602.940	2874	5	89.00		70-72/ 9598			
R-Class R 280 CDI (W251) Diesel				05/06 →	172	AH5010 (MLS) 30-030364-00	CH5010 21-30364-00/0	
R-Class R 280 CDI 4-matic (W251) Diesel				05/06 →		AH5020 (MLS) 30-030363-00		
R-Class R 320 CDI 4-matic (W251) Diesel				01/06 →				
OM 642.950	2987	6	83.00	Direct Injection, DOHC, V6	140/190			
R-Class R 500 4-matic (W251)				01/07 →	173	AG8440 (MLS) (30-029954-00)		
M 273.963	5461	8	98.00	Injection, DOHC, V8	285/388	AG8430 (MLS) (30-029953-00)		
S-Class 260 SE (W126)				09/85 → 06/91	174			
M 103.941	2599	6	82.90	Injection	117/159			

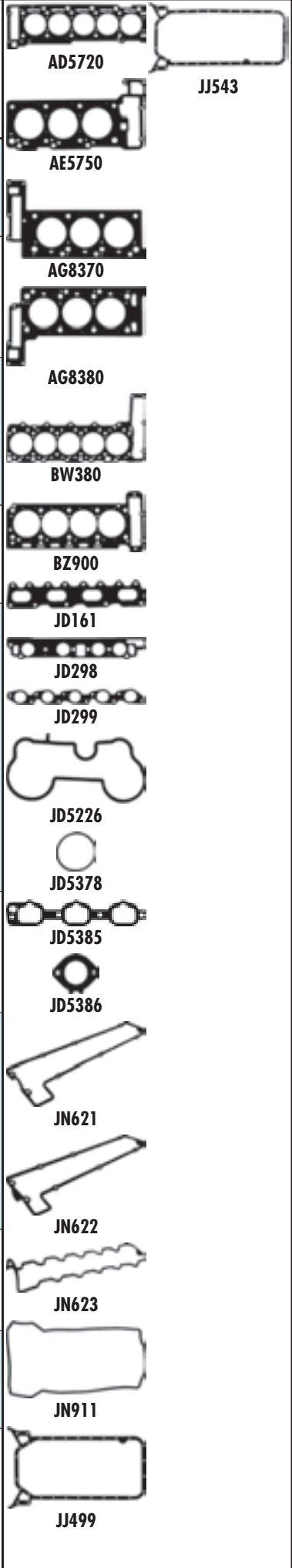
								
HBS150 Ⓢ (22-26009B) M12x1.75x102mm (x10)	JD5226 ■ (x2) (50-028038-00) JD161 ■ 31-027309-10	JN911 50-027307-00	JJ499 (31-027311-00)	HR5085 ■ (x4)	NA5131 ■ 45x67x8mm, PTFE (50-305910-50) NA5074 ■ 93x114x13mm, FPM (50-319192-00)	JM5111 (x4) [119]		AD5720 AE5750 AG8370 AG8380 BW380 BZ900 JD161 JD298 JD299 JD5226 JD5378 JD5385 JD5386 JN621 JN622 JN623 JN911 JJ499
HBS293 Ⓢ (22-26010B) M12x1.75x102mm (x12)	JD5378 ■ (x5) (50-029975-00) JD5798 ■ 31-030177-00	JM7028 (50-030203-00) HM5274 ■ 24-30181-00/0			NA5131 ■ 45x67x8mm, PTFE (50-319436-00) NA5074 ■ [3] 93x133.5x15.5mm, PTFE (50-319396-00)	NA5248 [2]■		
HBS474 Ⓢ (22-26025B) M12x1.75x205mm (x16)	JD5902 ■ (x2) 31-030365-00 (MLS)	HR397 [57] 34-000410-00	HR397 [57] 34-000410-00		NA5131 ■ 45x67x8mm, PTFE (50-319436-00)			
HBS463 (x2) (22-26020B) M11x1.5x141mm (x8)	JD5385 ■ (x2) (31-029992-00) JD5386 ■ (x6) (31-029993-00)	JM5236 ■ (50-029990-00) JM5237 ■ (50-029991-00)	HR397 [57] 34-000410-00		NA5131 ■ 45x67x8mm, PTFE (50-319436-00) NA5168 ■ 93x114x11.5mm, PTFE (50-319437-00)			
		HR397 [57] 34-000410-00	HR397 [57] 34-000410-00	HR280 ■ (x2) 24-30614-75/0	NA5131 ■ 45x67x8mm, PTFE (50-319436-00)	NA5248 [2]■		
HBS463 (x2) (22-26020B) M11x1.5x141mm (x8)	JD5385 ■ (x2) (31-029992-00) JD5386 ■ (x6) (31-029993-00)	JM5236 ■ (50-029990-00) JM5237 ■ (50-029991-00)	HR397 [57] 34-000410-00		NA5131 ■ 45x67x8mm, PTFE (50-319436-00) NA5168 ■ 93x114x11.5mm, PTFE (50-319437-00)			
HBS059 Ⓢ (22-26006B) M10x1.50x80mm (x5) M10x1.50x115mm (x6) M10x1.50x102mm (x11)	JD298 ■ 31-025171-30 JD299 ■ 31-025172-00	JN621 [195] 50-026033-00 JN622 [199] 50-026032-00	JJ543 (31-026946-00)	HR758 ■ 24-30637-45/0	NB973 ■ 45x67x8mm, FPM (50-305910-50) NB975 ■ 45x74.5x12mm, FPM (50-306557-50) NB974 ■ 93x114x13mm, FPM (50-319192-00) NA5074 ■ [3] 93x133.5x15.5mm, PTFE (50-319396-00)			
HBS474 Ⓢ (22-26025B) M12x1.75x205mm (x16)	JD5902 ■ (x2) 31-030365-00 (MLS)	HR397 [57] 34-000410-00	HR397 [57] 34-000410-00		NA5131 ■ 45x67x8mm, PTFE (50-319436-00)			
		HR397 [57] 34-000410-00	HR397 [57] 34-000410-00	HR791 ■ (x2) 24-30614-76/0	NA5131 ■ 45x67x8mm, PTFE (50-319436-00)			
HBS146 Ⓢ (22-26004B) M12x1.75x102mm (x14)		JN623 50-025260-10	JJ491 (31-026841-00)	HR759 ■ 24-30615-74/0	NC065 30x40x7mm, FPM (50-306142-00) NB975 ■ 45x74.5x12mm, FPM (50-306557-50) NB974 ■ 93x114x13mm, FPM (50-319192-00)	KK5683 [160]		

MERCEDES-BENZ



KW/PS



S-Class 280 S (W116)					08/72 → 07/80	175			EC821
S-Class 280 SE,SEL (W116)					08/72 → 07/80				22-26945-01/0
M 110.922	2746	6	86.00			115/156			
M 110.983/M 110.985	2746	6	86.00	K-Jetronic		136/185			
S-Class 280 S (W126)					12/79 → 07/85	176			EC821
M 110.924/M 110.926	2746	6	86.00			115/156			22-26945-01/0
S-Class 280 SE,SEL (W126)					10/79 → 07/85	177			EC821
M 110.987/M 110.989	2746	6	86.00	K-Jetronic		136/185			22-26945-01/0
S-Class 300 SE (W140)					01/93 → 10/98	178	AE5330 (Fibre), 1.24mm	CE5330 ○	
S-Class S 280 (W140)					02/93 → 10/98		30-027354-30	21-27354-51/0	
M 104.944	2799	6	89.90			142- 145/ 193- 197			
S-Class S 280 (W220)					10/98 → 08/05	179	AE5750 (MLS) ☒		
M 112.922	2799	6	89.90	V6		150/204	30-029988-00 AE5760 (MLS) ☒ 30-029989-00		
S-Class S 320 CDI (W221) Diesel					12/05 →	180	AH5010 (MLS) ☒	CH5010	
S-Class S 320 CDI 4-matic (W221) Diesel					10/06 →		30-030364-00	21-30364-00/0	
OM 642.930	2987	6	83.00	Direct Injection, DOHC, V6		173/235	AH5020 (MLS) ☒ 30-030363-00		
S-Class 300 SE,SEL (W126)					09/85 → 06/91	181	BN740 (Fibre)	HL657	
M 103.981 (KAT)	2962	6	88.50	KE-Jetronic		132/ 140/ 180/ 190	30-026903-00	21-26903-50/0	
S-Class S 300 Turbo-D (W140) Diesel					05/96 → 10/98	182	BY580 (Fibre)		EY580
OM 606.961	2996	6	87.00	DOHC		130/177	30-027831-00	(22-26394-50/0)	
S-Class 300 SE,SEL/S320 (W140)					03/91 → 10/98	183	AE5330 (Fibre), 1.24mm	CE5331	
M 104.990	3199	6	89.90	DOHC		170/231	30-027354-30	21-27354-21/0	
M 104.994	3199	6	89.90			170/231			
S-Class S 320 (W220)					10/98 → 08/05	184	AE5750 (MLS) ☒		
M 112.944	3199	6	89.90	V6		165/224	30-029988-00 AE5760 (MLS) ☒ 30-029989-00		
S-Class S 320 CDI (W220) Diesel					08/99 → 09/02	185	AG8490 (MLS)		
OM 613.960	3222	6	88.00	Direct Injection, DOHC		145/197	(30-030198-00)		
S-Class S 320 CDI (W220) Diesel					09/02 → 08/05	186	AG8490 (MLS)		
OM 648.960	3222	6	88.00	Direct Injection, DOHC		150/204	(30-030198-00)		











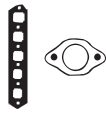

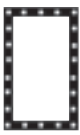

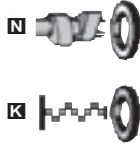



MERCEDES-BENZ



KW/PS



S-Class S 350 Turbo-D (W140) Diesel		01/93 → 10/98		187				DY601 <input type="checkbox"/> <input type="checkbox"/> <input type="checkbox"/>	
OM 603.971	3449	6	89.00	SOHC	110/150				
S-Class S 350 (W221)		10/05 →		188		AG8420 (MLS), 0.65mm <input checked="" type="checkbox"/>			
M 272.965	3498	6	92.90	Injection, DOHC, V6	200/272	(30-030052-00)			
						AG8410 (MLS), 0.65mm <input checked="" type="checkbox"/>			
						(30-030051-00)			
S-Class S 350 (W220)		09/02 → 08/05		189					
S-Class S 350 4-matic (W220)		06/03 → 08/05							
M 112.972/M 112.975	3724	6	97.00	Injection, V6	180/245				
S-Class 380 SE,SEL (W126)		12/79 → 08/85		190		BW220 (Fibre) <input checked="" type="checkbox"/>			
S-Class 380 SEC (C126)		10/81 → 07/85				30-024651-10			
M 116.963	3818	8	92.00	SOHC, V8	150/204				
S-Class 400 SE,SEL/S420 (W140)		02/91 → 10/98		191		AC5530 (Fibre) <input checked="" type="checkbox"/>			
S-Class S 420 (W140)		01/93 → 10/98				30-027156-00			
S-Class SEC/CL 420 (C140)		10/94 → 02/99				→ Eng.017 485			
M 119.971	4196	8	92.00	DOHC, V8	205/279				
M 119.981	4196	8	92.00	Injection, DOHC, V8	205/279				
S-Class S 430 (W220)		10/98 → 08/05		192					
M 113.941	4266	8	89.90	V8	205/279				
M 113.948	4266	8	89.90	Injection, DOHC, V8	205/279				
S-Class S 450 (W221)		12/05 →		193		AG8470 (MLS) <input checked="" type="checkbox"/>			
M 273.923	4663	8	92.90	Injection, DOHC, V8	250/340	(30-029951-00)			
						AG8480 (MLS) <input checked="" type="checkbox"/>			
						(30-029952-00)			
S-Class CL 500 (C216)		06/06 →		194		AG8440 (MLS) <input checked="" type="checkbox"/>			
S-Class S 500 (W221)		10/05 →				(30-029954-00)			
M 273.961	5461	8	97.20	Injection, DOHC, V8	285/388	AG8430 (MLS) <input checked="" type="checkbox"/>			
						(30-029953-00)			
SL Convertible 280 SL (R107)		08/74 → 07/85		195				EC821	
SL Coupe 280 SLC (C107)		08/74 → 09/81						22-26945-01/0	
M 110.982/ M 110.986/M 110.990	2746	6	86.00	K-Jetronic	136/185				
SL Convertible 280 SL (R129)		08/93 → 10/01		196		AE5330 (Fibre), 1.24mm		CE5330 <input type="checkbox"/>	
M 104.943	2799	6	89.90		142- 150/ 193- 204	30-027354-30		21-27354-51/0	
SL Convertible 280 SL (R129)		05/98 → 10/01		197		AE5750 (MLS) <input checked="" type="checkbox"/>			
M 112.923/M 112.925	2799	6	89.90	V6	150/204	30-029988-00			
						AE5760 (MLS) <input checked="" type="checkbox"/>			
						30-029989-00			
SL Convertible 300 SL (R107)		09/85 → 08/89		198		BN740 (Fibre)		HL657	
M 103.982	2962	6	88.50	KE-Jetronic	132/ 140/ 180/ 190	30-026903-00		21-26903-50/0	

								
HBS060 Ⓢ (22-26007B) M10x1.50x80mm (x6) M10x1.50x115mm (x7) M10x1.50x102mm (x13)	JD301 ■ (31-025174-00)	JN851 (50-026034-10)	JJ500 (31-026394-10)	HR760 ■ 24-30672-70/0	NA973 ■ 45x67x8mm, FPM (50-305910-50) NA974 ■ 93x114x13mm, FPM (50-319192-00)			 AC5530  AE5330  AE5750  BN740  BW220  JD167  JD301  JD5385  JD5386  JM5114  JN623  JN851  JJ500
		HR397 [57] 34-000410-00	HR397 [57] 34-000410-00	HR5062 ■ 24-30614-73/0	NA5131 ■ 45x67x8mm, PTFE (50-319436-00)			
HBS463 (x2) (22-26020B) M11x1.5x141mm (x8)	JD5385 ■ (x2) (31-029992-00) JD5386 ■ (x6) (31-029993-00)	JM5236 ■ (50-029990-00) JM5237 ■ (50-029991-00)	HR397 [57] 34-000410-00		NA5131 ■ 45x67x8mm, PTFE (50-319436-00) NA5168 ■ 93x114x11.5mm, PTFE (50-319437-00)			
			JH5113 (31-026467-10)		NA973 ■ 45x67x8mm, FPM (50-305910-50) NA5268 ■ 100x124x13mm, FPM (50-306799-50)			
				HR5085 ■ (x8)	NA973 ■ 45x67x8mm, FPM (50-305910-50) NA5268 ■ 100x124x13mm, FPM (50-306799-50)			
	JD5386 ■ (x8) (31-029993-00)			HR5055 ■ 24-30704-45/0	NA5131 ■ 45x67x8mm, PTFE (50-319436-00) NA5168 ■ 93x114x11.5mm, PTFE (50-319437-00)			
		HR397 [57] 34-000410-00	HR397 [57] 34-000410-00	HR791 ■ (x2) 24-30614-76/0	NA5131 ■ 45x67x8mm, PTFE (50-319436-00)			
		HR397 [57] 34-000410-00	HR397 [57] 34-000410-00	HR791 ■ (x2) 24-30614-76/0	NA5131 ■ 45x67x8mm, PTFE (50-319436-00)			
		PB256 (x5) HL659 ■ (24-2305701/0)		HL196 ■ (24-30637-41/0) HR754 ■ (24-24810-02/0)	PA815 ■ 78x94x8mm (31-019993-30)			
HBS152 Ⓢ (22-26071B) M12x1.75x160mm (x14)	JD167 ■ (x6) 50-027358-00 JD169 ■ (31-026443-10)	JM5114 (50-027355-10)	JJ500 (31-026394-10)	HR5055 ■ 24-30704-45/0	NA971 ■ 45x67x10mm, FPM (50-305913-50) NA974 ■ 93x114x13mm, FPM (50-319192-00)	JR5040 [45] KK5683 [160]		
HBS463 (x2) (22-26020B) M11x1.5x141mm (x8)	JD5385 ■ (x2) (31-029992-00) JD5386 ■ (x6) (31-029993-00)	JM5236 ■ (50-029990-00) JM5237 ■ (50-029991-00)	HR397 [57] 34-000410-00		NA5131 ■ 45x67x8mm, PTFE (50-319436-00) NA5168 ■ 93x114x11.5mm, PTFE (50-319437-00)			
HBS146 Ⓢ (22-26004B) M12x1.75x102mm (x14)		JN623 50-025260-10	JJ491 (31-026841-00)	HR759 ■ 24-30615-74/0	NC065 30x40x7mm, FPM (50-306142-00) NA971 ■ 45x67x10mm, FPM (50-305913-50) NA974 ■ 93x114x13mm, FPM (50-319192-00) NA5074 ■ [3] 93x133.5x15.5mm, PTFE (50-319396-00)	KK5683 [160]		

MERCEDES-BENZ



KW/PS



SL Convertible 300 SL (R129)				03/89 → 08/93	199	BN740 (Fibre)	HL657
M 103.984	2962	6	88.50	KE-Jetronic	132/ 140/ 180/ 190	30-026903-00	21-26903-50/0
SL Convertible 300 SL-24 (R129)				03/89 → 07/93	200	AC5520 (Fibre)	CC5520
M 104.981	2960	6	88.50	DOHC	162/ 170/ 220/ 231	30-027091-10	21-27091-20/0
SL Convertible 320 SL (R129)				09/93 → 10/01	201	AE5330 (Fibre), 1.24mm	CE5330
M 104.991	3199	6	89.90		170/231	30-027354-30	21-27354-51/0
SL Convertible 320 SL (R129)				05/98 → 10/01	202	AE5750 (MLS)	
M 112.943	3199	6	89.90	V6	165/224	30-029988-00 AE5760 (MLS) 30-029989-00	
SL Convertible 350 (R230)				03/03 →	203		
M 112.973	3724	6	97.00	Injection, V6	180/245		
SL 380 SL (R107)				09/80 → 08/85	204	BW220 (Fibre)	
M 116.962	3818	8	92.00	SOHC, V8	150/204	30-024651-10	
SL 500 (R129)				05/98 → 10/01	205		
SL 500 (R230)				10/01 →			
M 113.961/M 113.963	4966	8	97.00	DOHC, V8	220/299		
SL 55 AMG (R230)				10/01 → 06/02	206		
M 113.992	5439	8	97.00	Injection, V8	350- 368/ 476- 500		
SL 500 (R230)				03/06 →	207	AG8440 (MLS)	
M 273.965	5461	8	98.00	Injection, DOHC, V8	285/388	(30-029954-00) AG8430 (MLS) (30-029953-00)	
SL 55 AMG (R129)				03/00 → 10/01	208		
SL 55 AMG Kompressor (R230)				06/02 →			
M 113.985	5439	8	97.00	Injection, V8	260/354		
M 113.992	5439	8	97.00	Injection, V8	350- 368/ 476- 500		
SL 60 AMG (R129)				05/97 → 10/01	209		
SL 600 (R129)				07/92 → 10/01			
M 120.981	5987	8	89.00	DOHC, V12	280- 290/ 381- 394		
M 120.981	5987	12	89.00	DOHC, V12	280- 290/ 381- 394		
M 120.983	5987	12	89.00	DOHC, V12	290/394		

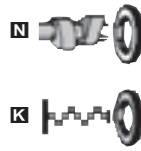
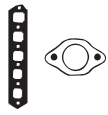

AC5520



AE5330



AE5750



BN740



BW220



JD167



JD5385



JD5386



JM5114



JN623

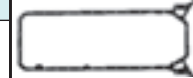

JJ500

HBS146 Ⓢ (22-26004B) M12x1.75x102mm (x14)		JN623 50-025260-10	JJ491 (31-026841-00)	HR759 Ⓢ 24-30615-74/0	NA NC065 30x40x7mm, FPM (50-306142-00) NA NB971 Ⓢ 45x67x10mm, FPM (50-305913-50) NA NB974 Ⓢ 93x114x13mm, FPM (50-319192-00) NA NA5074 Ⓢ [3] 93x133.5x15.5mm, PTFE (50-319396-00)	KK5683 [160]
HBS152 Ⓢ (22-26071B) M12x1.75x160mm (x14)	JD169 Ⓢ (31-026443-10)	JM5113 (50-026630-00)	JJ500 (31-026394-10)	HR5055 Ⓢ 24-30704-45/0	NA NB971 Ⓢ 45x67x10mm, FPM (50-305913-50) NA NB974 Ⓢ 93x114x13mm, FPM (50-319192-00)	JR5040 [45] KK5683 [160]
HBS152 Ⓢ (22-26071B) M12x1.75x160mm (x14)	JD167 Ⓢ (x6) 50-027358-00 JD169 Ⓢ (31-026443-10)	JM5114 (50-027355-10)	JJ500 (31-026394-10)	HR5055 Ⓢ 24-30704-45/0	NA NB971 Ⓢ 45x67x10mm, FPM (50-305913-50) NA NB974 Ⓢ 93x114x13mm, FPM (50-319192-00)	JR5040 [45] KK5683 [160]
HBS463 (x2) (22-26020B) M11x1.5x141mm (x8)	JD5385 Ⓢ (x2) (31-029992-00) JD5386 Ⓢ (x6) (31-029993-00)	JM5236 Ⓢ (50-029990-00) JM5237 Ⓢ (50-029991-00)	HR397 [57] 34-000410-00		NA NA5131 Ⓢ 45x67x8mm, PTFE (50-319436-00) NA NA5168 Ⓢ 93x114x11.5mm, PTFE (50-319437-00)	NA5248 [2]Ⓢ
HBS463 (x2) (22-26020B) M11x1.5x141mm (x8)	JD5385 Ⓢ (x2) (31-029992-00) JD5386 Ⓢ (x6) (31-029993-00)	JM5236 Ⓢ (50-029990-00) JM5237 Ⓢ (50-029991-00)	HR397 [57] 34-000410-00		NA NA5131 Ⓢ 45x67x8mm, PTFE (50-319436-00) NA NA5168 Ⓢ 93x114x11.5mm, PTFE (50-319437-00)	
			JH5113 (31-026467-10)		NA NB973 Ⓢ 45x67x8mm, FPM (50-305910-50) NA NA5268 Ⓢ 100x124x13mm, FPM (50-306799-50)	
	JD5386 Ⓢ (x8) (31-029993-00)		HR397 [57] 34-000410-00	HR5055 Ⓢ 24-30704-45/0	NA NA5131 Ⓢ 45x67x8mm, PTFE (50-319436-00) NA NA5168 Ⓢ 93x114x11.5mm, PTFE (50-319437-00)	
	JD5386 Ⓢ (x8) (31-029993-00)		HR397 [57] 34-000410-00	HR5055 Ⓢ 24-30704-45/0	NA NA5131 Ⓢ 45x67x8mm, PTFE (50-319436-00) NA NA5168 Ⓢ 93x114x11.5mm, PTFE (50-319437-00)	
		HR397 [57] 34-000410-00	HR397 [57] 34-000410-00	HR791 Ⓢ (x2) 24-30614-76/0	NA NA5131 Ⓢ 45x67x8mm, PTFE (50-319436-00)	
	JD5386 Ⓢ (x8) (31-029993-00)		HR397 [57] 34-000410-00	HR5055 Ⓢ 24-30704-45/0	NA NA5131 Ⓢ 45x67x8mm, PTFE (50-319436-00) NA NA5168 Ⓢ 93x114x11.5mm, PTFE (50-319437-00)	
	JD167 Ⓢ (x12) 50-027358-00 JD169 Ⓢ (x4) (31-026443-10)			HR5055 Ⓢ (x2) 24-30704-45/0 M120.983 Eng.000347 → M120.981	NA NC065 30x40x7mm, FPM (50-306142-00) NA NB973 Ⓢ 45x67x8mm, FPM (50-305910-50) NA NA5268 Ⓢ 100x124x13mm, FPM (50-306799-50)	











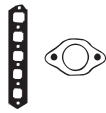

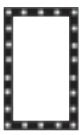

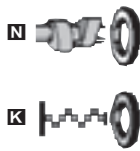



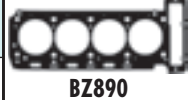

MERCEDES-BENZ



KW/PS



SLK Convertible 200 Kompressor (R171) 03/04 → 210						AG8790 (MLS) (30-030197-00)	CG8790 21-30197-00/0	
M 271.944	1795	4	82.00	DOHC	120/163			
SLK Convertible 200 (R170) 09/96 → 03/00 211						BZ880 (Fibre) 30-027462-10	DZ881 ■ □ ⊗ 21-27462-52/0	EV810 22-27311-50/0
SLK Convertible 200 Kompressor (R170) 10/96 → 03/00								
M 111.946	1998	4	89.90		100/136			
M 111.943	1998	4	89.90		132- 141/ 180- 192			
SLK Convertible 200 Kompressor (R170) 03/00 → 04/04 212						BZ880 (Fibre) 30-027462-10		
M 111.958	1998	4	89.90		120/163			
SLK Convertible 230 Kompressor (R170) 03/00 → 04/04 213						BZ890 (Fibre) 30-028037-00	DZ891 ■ □ ⊗ 21-28037-51/0	
M 111.983	2295	4	90.90	Injection, DOHC	145/197			
SLK Convertible 230 Kompressor (R170) 09/96 → 03/00 214						BZ880 (Fibre) 30-027462-10	DZ881 ■ □ ⊗ 21-27462-52/0	EV810 22-27311-50/0
M 111.973	2295	4	90.90	Injection, DOHC	142/193			
SLK Convertible 32 AMG Kompressor (R170) 03/01 → 04/04 215						AE5750 (MLS) ■ 30-029988-00		
SLK Convertible 320 (R170) 03/00 → 04/04						AE5760 (MLS) ■ 30-029989-00		
M 112.947	3199	6	89.90	V6	160/218			
M 112.960	3199	6	89.90	Injection, V6	260/354			
SLK Convertible 350 (R171) 06/04 → 216						AG8380 (MLS), 0.65mm ■ (30-029487-00) →Eng.30089232		
M 272.963	3498	6	92.90	Injection, DOHC, V6	200/272	AG8370 (MLS), 0.65mm ■ (30-029486-00) →Eng.30089232		
						AG8420 (MLS), 0.65mm ■ (30-030052-00) Eng.30089233 →		
						AG8410 (MLS), 0.65mm ■ (30-030051-00) Eng.30089233 →		
SLK 55 AMG (R171) 06/04 → 217								
M 113.989	5439	8	97.00	Injection, DOHC, V8	265/360			

								
HBS459 (22-26021B) M10x1.50x165.0mm (x10)	JD5835 (x4) 50-030167-00 (FPM) JD5801 31-030209-00	JM7026 50-030201-00	HR397 [57] 34-000410-00	HR5085 (x4)	NA5131 45x67x8mm, PTFE (50-319436-00)			 AE5750
HBS150 ⊕ (22-26009B) M12x1.75x102mm (x10)	JD5226 (x2) (50-028038-00) JD161 31-027309-10	JN911 50-027307-00 HM5057 24-27307-50/0	JH5082 (31-029265-00)	HR5085 (x4)	NB973 45x67x8mm, FPM (50-305910-50) NB974 93x114x13mm, FPM (50-319192-00)		JM5111 (x4) [119]	 AG8370  AG8380  BZ880  BZ890  JD161
HBS150 ⊕ (22-26009B) M12x1.75x102mm (x10)		JN911 50-027307-00 HM5057 24-27307-50/0	JH5082 (31-029265-00)	HR5085 (x4)	NB973 45x67x8mm, FPM (50-305910-50) NB974 93x114x13mm, FPM (50-319192-00)		JM5111 (x4) [119]	 JD5226  JD5385  JD5386
HBS150 ⊕ (22-26009B) M12x1.75x102mm (x10)	JD161 31-027309-10	JN911 50-027307-00 HM5057 24-27307-50/0	JJ499 (31-027311-00)	HR5085 (x4)	NB973 45x67x8mm, FPM (50-305910-50) NB974 93x114x13mm, FPM (50-319192-00)		JM5111 (x4) [119]	 JM5111
HBS150 ⊕ (22-26009B) M12x1.75x102mm (x10)	JD5226 (x2) (50-028038-00) JD161 31-027309-10	JN911 50-027307-00 HM5057 24-27307-50/0	JJ499 (31-027311-00)	HR5085 (x4)	NB973 45x67x8mm, FPM (50-305910-50) NB974 93x114x13mm, FPM (50-319192-00)		JM5111 (x4) [119]	 JM5111
HBS463 (x2) (22-26020B) M11x1.5x141mm (x8)	JD5385 (x2) (31-029992-00) JD5386 (x6) (31-029993-00)	JM5236 (50-029990-00) JM5237 (50-029991-00)	HR397 [57] 34-000410-00		NA5131 45x67x8mm, PTFE (50-319436-00) NA5168 93x114x11.5mm, PTFE (50-319437-00)		NA5248 [2] [1]	 JN911
		HR397 [57] 34-000410-00	HR397 [57] 34-000410-00	HR280 (x2) 24-30614-75/0	NA5131 45x67x8mm, PTFE (50-319436-00)		NA5248 [2] [1]	 JH5082  JJ499
	JD5386 (x8) (31-029993-00)		HR397 [57] 34-000410-00	HR5055 24-30704-45/0	NA5131 45x67x8mm, PTFE (50-319436-00) NA5168 93x114x11.5mm, PTFE (50-319437-00)		NA5248 [2] [1]	











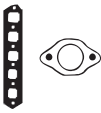

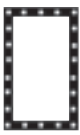

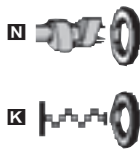



MERCEDES-BENZ



KW/PS



Sprinter 208 CDI (901, 902) Diesel 04/00 → 05/06 218					AC5620 (MLS), 1.20mm 30-029263-00	CC5620 (21-29263-30/0)	EC5620 22-29263-00/0
Sprinter 211 CDI (901, 902) Diesel 04/00 → 05/06							
Sprinter 213 CDI (901, 902) Diesel 04/00 → 05/06							
Sprinter 308 CDI (903) Diesel 04/00 → 05/06							
Sprinter 311 CDI (903) Diesel 04/00 → 05/06							
Sprinter 311 CDI 4x4 (903) Diesel 08/02 → 05/06							
Sprinter 313 CDI (903) Diesel 04/00 → 05/06							
Sprinter 313 CDI 4x4 (903) Diesel 08/02 → 05/06							
Sprinter 408 CDI (904) Diesel 04/00 → 05/06							
Sprinter 411 CDI (904) Diesel 04/00 → 05/06							
Sprinter 411 CDI 4x4 (904) Diesel 04/00 → 05/06							
Sprinter 413 CDI (904) Diesel 04/00 → 05/06							
Sprinter 413 CDI 4x4 (904) Diesel 04/00 → 05/06							
OM 611.987	2148	4	88.00	Direct Injection, DOHC	60/81		
OM 611.981	2148	4	88.00	Direct Injection, DOHC	80-95/ 109- 129		
Sprinter 311 CDI 4x4 (903) Diesel 08/02 → 05/06 219					AC5620 (MLS), 1.20mm 30-029263-00	CC5620 (21-29263-30/0)	EC5620 22-29263-00/0
OM 611.981	2148	4	88.00	Direct Injection, DOHC			
Sprinter 208 D (901, 902) Diesel 01/95 → 04/00 220					BW370 (Fibre) 30-027217-20	DW370 21-27217-51/0 DW372 [196] 21-27217-53/0 DW373 [195] (21-27217-54/0)	EM720 22-24895-01/0
Sprinter 308 D 2.3L (903) Diesel 02/95 → 04/00							
Sprinter 408 D (904) Diesel 02/96 → 05/06							
OM 601.943	2299	4	89.00		58/79		
Sprinter 208 D (901, 902) Diesel 09/96 → 04/00 221					BW370 (Fibre) 30-027217-20	DW370 21-27217-51/0	EM720 22-24895-01/0
	2299	4					
Sprinter 214 (901, 902) 02/95 → 05/06 222					BZ900 (Fibre) 30-027971-00	DZ160 21-27971-50/0	EV810 22-27311-50/0
Sprinter 214 NGT (901, 902) 04/00 → 05/06							
Sprinter 314 (903) 02/95 → 05/06							
Sprinter 314 4x4 (903) 08/02 → 05/06							
Sprinter 314 NGT (903) 04/00 → 05/06							
Sprinter 414 (904) 02/96 → 05/06							
Sprinter 414 4x4 (904) 05/97 → 05/06							
M 111.984	2295	4					
	2295	4	90.90	Injection, DOHC	92-105/ 125- 143		
M 111.979	2295	4	90.90	Injection, DOHC	105/143		
Sprinter 214 NGT (901, 902) 04/00 → 05/06 223					BZ900 (Fibre) 30-027971-00	DZ160 21-27971-50/0 Eng.000 740 → Eng.003 501 →	EV810 22-27311-50/0
Sprinter 314 NGT (903) 04/00 → 05/06							
/M 111.984	2295	4					

								 AC5620
HBS292 Ⓢ (22-26011B) M12x1.75x102mm (x10)	JD5379 ■ (x4) (50-029976-00) (Rubber) JD5380 ■ (31-029977-00) (MLS)	HM5170 24-29264-00/0	JH5082 [6] (31-029265-00)	HR5085 ■ (x4)	NA5131 ■ 45x67x8mm, PTFE (50-319436-00) NA5074 ■ [3] 93x133.5x15.5mm, PTFE (50-319396-00)	KA5035 [13] KA5036 [13]		 BW370
HBS292 Ⓢ (22-26011B) M12x1.75x102mm (x10)	JD5379 ■ (x4) (50-029976-00) (Rubber) JD5380 ■ (31-029977-00) (MLS)	HM5170 24-29264-00/0	JH5082 [6] (31-029265-00)	HR5085 ■ (x4)	NA5131 ■ 45x67x8mm, PTFE (50-319436-00) NA5074 ■ [3] 93x133.5x15.5mm, PTFE (50-319396-00)	KA5035 [13] KA5036 [13]		 BZ900
HBS058 Ⓢ (22-26069B) M10x1.50x80mm (x4) M10x1.50x115mm (x5) M10x1.50x102mm (x9)	JD158 ■ JD159 ■ 31-024911-00	JN572 [196] 50-026030-00 JN619 [195] 50-026031-00	JJ498 (31-026923-00)	HR757 ■ 24-30672-71/0	NB973 ■ 45x67x8mm, FPM (50-305910-50) NB974 ■ 93x114x13mm, FPM (50-319192-00)	KK5683 [160]		 JD158
HBS058 Ⓢ (22-26069B) M10x1.50x80mm (x4) M10x1.50x115mm (x5) M10x1.50x102mm (x9)	JD158 ■ JD159 ■ 31-024911-00	JN572 [196] 50-026030-00 JN619 [195] 50-026031-00	JJ498 (31-026923-00)	HR757 ■ 24-30672-71/0	NB973 ■ 45x67x8mm, FPM (50-305910-50) NB974 ■ 93x114x13mm, FPM (50-319192-00)			 JD159
HBS150 Ⓢ (22-26009B) M12x1.75x102mm (x10)	JD160 ■ (31-027310-00) JD161 ■ 31-027309-10	JN911 50-027307-00 HM5057 ■ 24-27307-50/0	JJ499 (31-027311-00)	HR5085 ■ (x4)	NB973 ■ 45x67x8mm, FPM (50-305910-50) NB974 ■ 93x114x13mm, FPM (50-319192-00)	JM5111 (x4) [119]		 JD160
HBS150 Ⓢ (22-26009B) M12x1.75x102mm (x10)	JD160 ■ (31-027310-00) JD161 ■ 31-027309-10	JN911 50-027307-00 HM5057 ■ 24-27307-50/0	JJ499 (31-027311-00)	HR5085 ■ (x4)	NB973 ■ 45x67x8mm, FPM (50-305910-50) NB974 ■ 93x114x13mm, FPM (50-319192-00)	JM5111 (x4) [119]		 JD161
HBS150 Ⓢ (22-26009B) M12x1.75x102mm (x10)	JD160 ■ (31-027310-00) JD161 ■ 31-027309-10	JN911 50-027307-00 HM5057 ■ 24-27307-50/0	JJ499 (31-027311-00)	HR5085 ■ (x4)	NB973 ■ 45x67x8mm, FPM (50-305910-50) NB974 ■ 93x114x13mm, FPM (50-319192-00)	JM5111 (x4) [119]		 JN572
								 JN619
								 JN911
								 JH5082
								 JJ498
								 JJ499











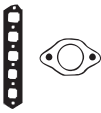

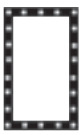

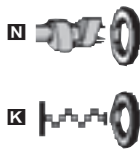

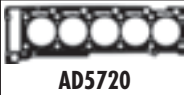

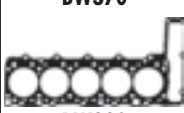
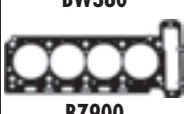

MERCEDES-BENZ



KW/PS



Sprinter 308 D (903) Diesel		02/95 → 04/00		224	BW370 (Fibre)	DW370	EM720
	2299	4		60/82	30-027217-20	21-27217-51/0 DW372 [196] 21-27217-53/0 DW373 [195] [21-27217-54/0]	22-24895-01/0
Sprinter 308 D (903) Diesel		02/95 → 04/00		225	BW370 (Fibre)	DW370	EM720
OM 601.943	2299	4	89.00	58/79	30-027217-20	21-27217-51/0 DW372 21-27217-53/0 DW373 [21-27217-54/0]	22-24895-01/0
Sprinter 308 D (903) Diesel		11/96 → 04/00		226	BW370 (Fibre)	DW370	EM720
	2299	4		60/82	30-027217-20	21-27217-51/0	22-24895-01/0
Sprinter 314 4x4 (903)		08/02 → 05/06		227	BZ900 (Fibre)	DZ160	EV810
M 111.984	2295	4	90.90	Injection, DOHC	92-105/ 125- 143 Eng.000740 → Eng.003501 →	30-027971-00 21-27971-50/0 Eng.000 740 → Eng.003 501 →	22-27311-50/0
M 111.979	2295	4	90.90	Injection, DOHC	105/143		
Sprinter 216 CDI (901, 902) Diesel		04/00 → 05/06		228	AD5720 (MLS), 1.20mm	CD5720	ED5720
					30-029696-00	21-29696-00/0	[22-30373-00/0]
Sprinter 316 CDI (903) Diesel		04/00 → 05/06					
Sprinter 316 CDI 4x4 (903) Diesel		08/02 → 05/06					
Sprinter 416 CDI (904) Diesel		04/00 → 05/06					
Sprinter 416 CDI 4x4 (904) Diesel		04/00 → 05/06					
OM 612.981	2685	5	88.00	Direct Injection, DOHC	110- 115/ 150- 156		
Sprinter 616 CDI (905) Diesel		04/01 →		229	AD5720 (MLS), 1.20mm	CD5720	ED5720
OM 612.981	2685	5	88.00	Direct Injection, DOHC	110- 115/ 150- 156	30-029696-00 21-29696-00/0	[22-30373-00/0]
Sprinter 210 D (901, 902) Diesel		01/97 → 04/00		230	BW380 (Fibre), 1.80mm	DW381	EN720
					30-026270-20	21-28404-50/0	22-26946-01/0
Sprinter 212 D (901, 902) Diesel		02/95 → 04/00					
Sprinter 310 D (903) Diesel		02/95 → 08/02					
Sprinter 310 D 2.9L (903) Diesel		01/97 → 04/00					
Sprinter 312 D (903) Diesel		02/95 → 04/00					
Sprinter 312 D 2.9L (903) Diesel		02/95 → 08/02					
Sprinter 312 D 2.9L 4x4 (903) Diesel		05/97 → 08/02					
Sprinter 410 D (904) Diesel		02/96 → 05/06					
Sprinter 410 D 4x4 (904) Diesel		05/97 → 05/06					
Sprinter 412 D (904) Diesel		02/96 → 05/06					
Sprinter 412 D 4x4 (904) Diesel		05/97 → 05/06					
OM 602.980	2874	5	89.00		75-90/ 102- 122		

								
HBS058 Ⓞ <i>(22-26069B)</i> M10x1.50x80mm (x4) M10x1.50x115mm (x5) M10x1.50x102mm (x9)	JD158 ■ JD159 ■ 31-024911-00	JN572 [196] 50-026030-00 JN619 [195] 50-026031-00	JJ498 <i>(31-026923-00)</i>	HR757 ■ 24-30672-71/0	NB973 ■ 45x67x8mm, FPM <i>(50-305910-50)</i> NB974 ■ 93x114x13mm, FPM <i>(50-319192-00)</i>			 AD5720  BW370  BW380  BZ900  JD158  JD159  JD160  JD161  JD298  JD299  JN572  JN619  JN621  JN622  JN911  JJ498
HBS058 Ⓞ <i>(22-26069B)</i> M10x1.50x80mm (x4) M10x1.50x115mm (x5) M10x1.50x102mm (x9)	JD158 ■ JD159 ■ 31-024911-00	JN572 [196] 50-026030-00 JN619 [195] 50-026031-00	JJ498 <i>(31-026923-00)</i>	HR757 ■ 24-30672-71/0	NB973 ■ 45x67x8mm, FPM <i>(50-305910-50)</i> NB974 ■ 93x114x13mm, FPM <i>(50-319192-00)</i>		KK5683 [160]	
HBS058 Ⓞ <i>(22-26069B)</i> M10x1.50x80mm (x4) M10x1.50x115mm (x5) M10x1.50x102mm (x9)	JD158 ■ JD159 ■ 31-024911-00	JN572 [196] 50-026030-00 JN619 [195] 50-026031-00	JJ498 <i>(31-026923-00)</i>		NB973 ■ 45x67x8mm, FPM <i>(50-305910-50)</i> NB974 ■ 93x114x13mm, FPM <i>(50-319192-00)</i>			
HBS150 Ⓞ <i>(22-26009B)</i> M12x1.75x102mm (x10)	JD160 ■ <i>(31-027310-00)</i> JD161 ■ 31-027309-10	JN911 50-027307-00 HM5057 ■ 24-27307-50/0	JJ499 <i>(31-027311-00)</i>	HR5085 ■ (x4)	NB973 ■ 45x67x8mm, FPM <i>(50-305910-50)</i> NB974 ■ 93x114x13mm, FPM <i>(50-319192-00)</i>		JM5111 (x4) [119]	
HBS293 Ⓞ <i>(22-26010B)</i> M12x1.75x102mm (x12)	JD5797 ■ <i>(31-030176-00)</i> JD5798 ■ 31-030177-00	JM7028 <i>(50-030203-00)</i> HM5274 ■ 24-30181-00/0		HR5085 ■ (x5)	NA5131 ■ 45x67x8mm, PTFE <i>(50-319436-00)</i> NA5074 ■ [3] 93x133.5x15.5mm, PTFE <i>(50-319396-00)</i>			
HBS293 Ⓞ <i>(22-26010B)</i> M12x1.75x102mm (x12)	JD5797 ■ <i>(31-030176-00)</i> JD5798 ■ 31-030177-00	JM7028 <i>(50-030203-00)</i> HM5274 ■ 24-30181-00/0		HR5085 ■ (x5)	NA5131 ■ 45x67x8mm, PTFE <i>(50-319436-00)</i> NA5074 ■ [3] 93x133.5x15.5mm, PTFE <i>(50-319396-00)</i>			
HBS059 Ⓞ <i>(22-26006B)</i> M10x1.50x80mm (x5) M10x1.50x115mm (x6) M10x1.50x102mm (x11)	JD298 ■ 31-025171-30 JD299 ■ 31-025172-00	JN621 [195] 50-026033-00 JN622 [196] 50-026032-00	JJ543 <i>(31-026946-00)</i>	HR758 ■ 24-30637-45/0	NA5131 ■ 45x67x8mm, PTFE <i>(50-319436-00)</i> NB974 ■ 93x114x13mm, FPM <i>(50-319192-00)</i>			







MERCEDES-BENZ

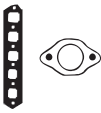

KW/PS

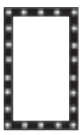

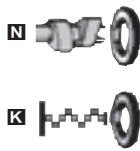
T1 Box 208 D (601) Diesel 10/88 → 02/96 231						BW370 (Fibre) 30-027217-20	DW370 21-27217-51/0	EM720 22-24895-01/0
T1 Flatbed 208 D (601) Diesel 11/88 → 02/96								
T1 Bus 208 D (601) Diesel 10/88 → 02/96								
T1 Box 308 D (602) Diesel 11/88 → 02/96								
T1 Flatbed 308 D (602) Diesel 06/89 → 02/96								
OM 601.940	2299	4	89.00		58-60/ 79-82			
T1 Box 210 (601) 07/82 → 02/96 232						BH880 (Fibre) 30-026005-10	DH882 21-26005-54/0	
T1 Flatbed 210 (601) 04/77 → 10/89								
T1 Bus 210 (601) 07/82 → 01/90								
M 102.942	2298	4	95.50	SOHC	70/95			
M 102.946	2299	4	95.50	Injection, SOHC	70/95			
T1 Box 210 (601) 05/89 → 02/96 233						BH880 (Fibre) 30-026005-10	DH882 21-26005-54/0	
T1 Bus 210 (601) 05/89 → 02/96								
M 102.945	2299	4	95.50	SOHC	77/105			
T1 Bus 207 D (601) Diesel 05/77 → 01/90 234						BC790 (Fibre) 30-024065-10	DC790 21-24065-24/0	EC790 (22-26944-01/0) GC790 20-24065-01/0
T1 Flatbed 207 D (601) Diesel 04/77 → 12/82								
T1 Flatbed 307 D (602) Diesel 06/82 → 01/90								
OM 616.917/OM 616.934	2376 2399	4 4	90.90		53/72 48/65			
OM 616.937/OM 616.939	2399	4	90.90		53/72			
T1 Box 207 D (601) Diesel 06/82 → 01/90 235						BC790 (Fibre) 30-024065-10	DC790 21-24065-24/0	EC790 (22-26944-01/0) GC790 20-24065-01/0
T1 Flatbed 207 D (601) Diesel 12/77 → 10/89								
T1 Box 307 D (602) Diesel 10/82 → 01/90								
T1 Flatbed 307 D (602) Diesel 04/77 → 01/83								
OM 616.937/OM 616.939	2399	4	90.90		53/72			
T1 Box 210 D (601) Diesel 10/88 → 02/96 236						BW380 (Fibre), 1.80mm 30-026270-20	DW381 21-28404-50/0	EN720 22-26946-01/0
T1 Bus 210 D (601) Diesel 11/88 → 02/96								
T1 Flatbed 210 D (601) Diesel 11/88 → 02/96								
OM 602.940	2874	5	89.00		70-72/ 9598			
T1 Box 209 D (601) Diesel 12/82 → 01/90 237						BC800 (Fibre) 30-023973-10	DC800 21-23973-24/0	EC791 (22-26944-02/0)
T1 Flatbed 209 D (601) Diesel 12/82 → 01/90								
T1 Bus 209 D (601) Diesel 12/82 → 01/90								
OM 617.913	2998	5	87.00		65/88			
T1 Flatbed 210 D (601) Diesel 11/88 → 02/96 238						BW380 (Fibre), 1.80mm 30-026270-20	DW381 21-28404-50/0	EN720 22-26946-01/0
T1 Flatbed 310 D (602) Diesel 06/89 → 02/96								
T1 Box 310 D (602) Diesel 06/89 → 02/96								
T1 Bus 310 D (602) Diesel 06/89 → 02/96								
OM 602.940	2874	5	89.00		70-72/ 9598			
T1 Flatbed 309 D (602) Diesel 10/82 → 01/90 239						BC800 (Fibre) 30-023973-10	DC800 21-23973-24/0	EC791 (22-26944-02/0)
T1 Box 309 D (602) Diesel 10/82 → 01/90								
OM 617.913	2998	5	87.00		65/88			

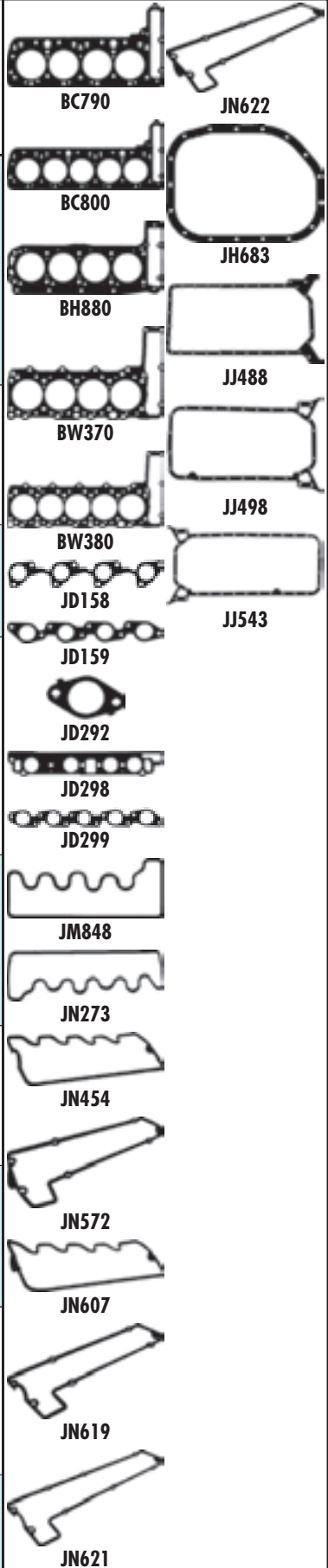
								
HBS058 Ⓢ [22-26069B] M10x1.50x80mm (x4) M10x1.50x115mm (x5) M10x1.50x102mm (x9)	JD158 ■ JD159 ■ 31-024911-00	JN572 [196] 50-026030-00 JN619 [195] 50-026031-00	JJ498 (31-026923-00)	HR757 ■ 24-30672-71/0	NA973 ■ 45x67x8mm, FPM (50-305910-50) NA974 ■ 93x114x13mm, FPM (50-319192-00)	KK5683 [160]	BC790 BC800 BH880 BW370 BW380 JD158 JD159 JD292 JD298 JD299 JM848 JN273 JN454 JN572 JN607 JN619 JN621	JN622 JH683 JJ488 JJ498 JJ543
HBS047 Ⓢ [22-26065B] M12x1.75x120mm (x10)	JD292 ■ 31-026634-10	JN454 [195] 50-024959-10 JN607 [196] 50-025120-10	JJ488 (31-026812-00)	HR756 ■ 24-30615-70/0	NA973 ■ 45x67x8mm, FPM (50-305910-50) NA974 ■ 93x114x13mm, FPM (50-319192-00)		BC790 BC800 BH880 BW370 BW380 JD158 JD159 JD292 JD298 JD299 JM848 JN273 JN454 JN572 JN607 JN619 JN621	JH683 JJ488 JJ498 JJ543
HBS047 Ⓢ [22-26065B] M12x1.75x120mm (x10)		JN454 [195] 50-024959-10 JN607 [196] 50-025120-10		HR756 ■ 24-30615-70/0	NA973 ■ 45x67x8mm, FPM (50-305910-50) NA974 ■ 93x114x13mm, FPM (50-319192-00)		BC790 BC800 BH880 BW370 BW380 JD158 JD159 JD292 JD298 JD299 JM848 JN273 JN454 JN572 JN607 JN619 JN621	JH683 JJ488 JJ498 JJ543
HBS045 Ⓢ [22-26067B] M12x1.75x105mm (x4) M12x1.75x145mm (x6) M12x1.75x120mm (x8)	JB162 (31-024970-20)	JM848 50-022825-00	JH683 (31-026944-00)		PA815 ■ 78x94x8mm (31-019993-30)		BC790 BC800 BH880 BW370 BW380 JD158 JD159 JD292 JD298 JD299 JM848 JN273 JN454 JN572 JN607 JN619 JN621	JH683 JJ488 JJ498 JJ543
HBS045 Ⓢ [22-26067B] M12x1.75x105mm (x4) M12x1.75x145mm (x6) M12x1.75x120mm (x8)		JM848 50-022825-00	JH683 (31-026944-00)		PA815 ■ 78x94x8mm (31-019993-30)		BC790 BC800 BH880 BW370 BW380 JD158 JD159 JD292 JD298 JD299 JM848 JN273 JN454 JN572 JN607 JN619 JN621	JH683 JJ488 JJ498 JJ543
HBS059 Ⓢ [22-26006B] M10x1.50x80mm (x5) M10x1.50x115mm (x6) M10x1.50x102mm (x11)	JD298 ■ 31-025171-30 JD299 ■ 31-025172-00	JN621 [195] 50-026033-00 JN622 [196] 50-026032-00	JJ543 (31-026946-00)	HR758 ■ 24-30637-45/0	NA5131 ■ 45x67x8mm, PTFE (50-319436-00) NA974 ■ 93x114x13mm, FPM (50-319192-00)		BC790 BC800 BH880 BW370 BW380 JD158 JD159 JD292 JD298 JD299 JM848 JN273 JN454 JN572 JN607 JN619 JN621	JH683 JJ488 JJ498 JJ543
HBS046 Ⓢ [22-26068B] M12x1.75x145mm (x8) M12x1.75x120mm (x9) M12x1.75x105mm (x5)	JD297 ■ (31-024532-10)	JN273 (50-023445-20)	JH683 (31-026944-00)		NB975 ■ 45x74.5x12mm, FPM (50-306557-50) PA815 ■ 78x94x8mm (31-019993-30)		BC790 BC800 BH880 BW370 BW380 JD158 JD159 JD292 JD298 JD299 JM848 JN273 JN454 JN572 JN607 JN619 JN621	JH683 JJ488 JJ498 JJ543
HBS059 Ⓢ [22-26006B] M10x1.50x80mm (x5) M10x1.50x115mm (x6) M10x1.50x102mm (x11)	JD298 ■ 31-025171-30 JD299 ■ 31-025172-00	JN621 [195] 50-026033-00 JN622 [196] 50-026032-00	JJ543 (31-026946-00)	HR758 ■ 24-30637-45/0	NA5131 ■ 45x67x8mm, PTFE (50-319436-00) NA974 ■ 93x114x13mm, FPM (50-319192-00)		BC790 BC800 BH880 BW370 BW380 JD158 JD159 JD292 JD298 JD299 JM848 JN273 JN454 JN572 JN607 JN619 JN621	JH683 JJ488 JJ498 JJ543
HBS046 Ⓢ [22-26068B] M12x1.75x145mm (x8) M12x1.75x120mm (x9) M12x1.75x105mm (x5)	JD297 ■ (31-024532-10)	JN273 (50-023445-20)	JH683 (31-026944-00)		NB975 ■ 45x74.5x12mm, FPM (50-306557-50) PA815 ■ 78x94x8mm (31-019993-30)		BC790 BC800 BH880 BW370 BW380 JD158 JD159 JD292 JD298 JD299 JM848 JN273 JN454 JN572 JN607 JN619 JN621	JH683 JJ488 JJ498 JJ543











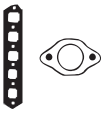

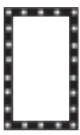

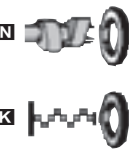

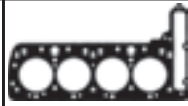

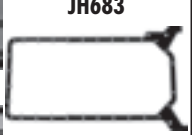

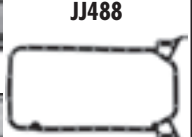

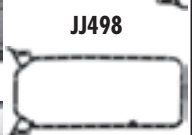
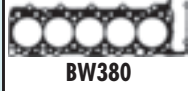

MERCEDES-BENZ



KW/PS

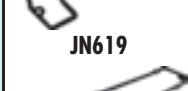

T1/TN 408 D Diesel				11/88 → 06/95	240	BW370 (Fibre)	DW370	EM720
OM 601.940	2299	4	89.00		58-60/ 79-82	30-027217-20	21-27217-51/0 DW372 21-27217-53/0 DW373 (21-27217-54/0)	22-24895-01/0
T1/TN 408 D Diesel				11/88 → 06/95	241	BW370 (Fibre)	DW370	EM720
OM 601.940	2299	4	89.00		58-60/ 79-82	30-027217-20	21-27217-51/0 DW372 21-27217-53/0 DW373 (21-27217-54/0)	22-24895-01/0
T1/TN 410				08/82 → 06/95	242	BH880 (Fibre)		
M 102.942	2298	4	95.50	SOHC	70/95	30-026005-10		
M 102.945	2299	4	95.50	SOHC	77/105			
T1/TN 407 D Diesel				07/81 → 01/89	243	BC790 (Fibre)	DC790	EC790
OM 616.913	2398	4	91.00	SOHC	53/72	30-024065-10	21-24065-24/0	(22-26944-01/0)
OM 616.939	2399	4	90.90		53/72			GC790 20-24065-01/0
T1/TN 407 D Diesel				07/81 → 01/89	244	BC790 (Fibre)	DC790	EC790
OM 616.913	2398	4	91.00	SOHC	53/72	30-024065-10	21-24065-24/0	(22-26944-01/0)
OM 616.939	2399	4	90.90		53/72			GC790 20-24065-01/0
T1/TN 410 D Diesel				11/88 → 06/95	245	BW380 (Fibre), 1.80mm	DW380	EN720
OM 602.940	2874	5	89.00		70-72/ 95-98	30-026270-20	21-26270-52/0	22-26946-01/0
T1/TN 409 D Diesel				04/82 → 01/89	246	BC800 (Fibre)	DC800	EC791
OM 617.913	2998	5	87.00		65/88	30-023973-10	21-23973-24/0	(22-26944-02/0)
T2/L L 407 D Diesel				01/75 → 12/88	247	BC790 (Fibre)	DC790	EC790
OM 616.910	2400	4	91.00	SOHC	48/65	30-024065-10	21-24065-24/0	(22-26944-01/0) GC790 20-24065-01/0

								
HBS058 ® (22-26069B) M10x1.50x80mm (x4) M10x1.50x115mm (x5) M10x1.50x102mm (x9)	JB162 (31-024970-20) JD159 ■ 31-024911-00	JN572 [196] 50-026030-00 JN619 [195] 50-026031-00	JJ498 (31-026923-00)	HR757 ■ 24-30672-71/0	<input checked="" type="checkbox"/> NB973 ■ 45x67x8mm, FPM (50-305910-50) <input checked="" type="checkbox"/> NB975 ■ 45x74.5x12mm, FPM (50-306557-50) <input checked="" type="checkbox"/> NB974 ■ 93x114x13mm, FPM (50-319192-00) <input checked="" type="checkbox"/> NA5074 ■ [3] 93x133.5x15.5mm, PTFE (50-319396-00)	KK5683 [160]		 BC790  JH683  BC800  JJ488  BH880  JJ498  BW370  JJ543  BW380  JD159  JD292  JD298  JD299  JM848  JN273  JN454  JN572  JN607  JN619  JN621  JN622
HBS058 ® (22-26069B) M10x1.50x80mm (x4) M10x1.50x115mm (x5) M10x1.50x102mm (x9)	JD159 ■ 31-024911-00	JN572 [196] 50-026030-00 JN619 [195] 50-026031-00	JJ498 (31-026923-00)	HR757 ■ 24-30672-71/0	<input checked="" type="checkbox"/> NB973 ■ 45x67x8mm, FPM (50-305910-50) <input checked="" type="checkbox"/> NB975 ■ 45x74.5x12mm, FPM (50-306557-50) <input checked="" type="checkbox"/> NB974 ■ 93x114x13mm, FPM (50-319192-00) <input checked="" type="checkbox"/> NA5074 ■ [3] 93x133.5x15.5mm, PTFE (50-319396-00)	KK5683 [160]		
	JD292 ■ (x4) 31-026634-10	JN454 [195] 50-024959-10 JN607 [196] 50-025120-10	JJ488 (31-026812-00)	HR756 ■ 24-30615-70/0	<input checked="" type="checkbox"/> NB973 ■ 45x67x8mm, FPM (50-305910-50) <input checked="" type="checkbox"/> NB975 ■ 45x74.5x12mm, FPM (50-306557-50) <input checked="" type="checkbox"/> NB974 ■ 93x114x13mm, FPM (50-319192-00) <input checked="" type="checkbox"/> NA5074 ■ [3] 93x133.5x15.5mm, PTFE (50-319396-00)			
HBS045 ® (22-26067B) M12x1.75x105mm (x4) M12x1.75x145mm (x6) M12x1.75x120mm (x8)	JB162 (31-024970-20)	JM848 50-022825-00	JH683 (31-026944-00)		<input checked="" type="checkbox"/> NB975 ■ 45x74.5x12mm, FPM (50-306557-50) <input checked="" type="checkbox"/> NB978 ■ 65x90x13mm, FPM (50-306307-00) <input checked="" type="checkbox"/> PA815 ■ (x1) 78x94x8mm (31-019993-30)			
HBS045 ® (22-26067B) M12x1.75x105mm (x4) M12x1.75x145mm (x6) M12x1.75x120mm (x8)	JD297 ■ (31-024532-10) JB162 (31-024970-20)	JM848 50-022825-00	JH683 (31-026944-00)		<input checked="" type="checkbox"/> NB975 ■ 45x74.5x12mm, FPM (50-306557-50) <input checked="" type="checkbox"/> NB978 ■ 65x90x13mm, FPM (50-306307-00) <input checked="" type="checkbox"/> PA815 ■ (x1) 78x94x8mm (31-019993-30)			
HBS059 ® (22-260606B) M10x1.50x80mm (x5) M10x1.50x115mm (x6) M10x1.50x102mm (x11)	JD298 ■ 31-025171-30 JD299 ■ 31-025172-00	JN621 [195] 50-026033-00 JN622 [196] 50-026032-00	JJ543 (31-026946-00)	HR758 ■ 24-30637-45/0	<input checked="" type="checkbox"/> NB973 ■ 45x67x8mm, FPM (50-305910-50) <input checked="" type="checkbox"/> NB975 ■ 45x74.5x12mm, FPM (50-306557-50) <input checked="" type="checkbox"/> NB974 ■ 93x114x13mm, FPM (50-319192-00) <input checked="" type="checkbox"/> NA5074 ■ [3] 93x133.5x15.5mm, PTFE (50-319396-00)			
	JD297 ■ (31-024532-10)	JN273 (50-023445-20)	JH683 (31-026944-00)		<input checked="" type="checkbox"/> NB975 ■ 45x74.5x12mm, FPM (50-306557-50) <input checked="" type="checkbox"/> NB978 ■ 65x90x13mm, FPM (50-306307-00) <input checked="" type="checkbox"/> PA815 ■ (x1) 78x94x8mm (31-019993-30)			
HBS045 ® (22-26067B) M12x1.75x105mm (x4) M12x1.75x145mm (x6) M12x1.75x120mm (x8)	JB162 (31-024970-20)	JM848 50-022825-00	JH683 (31-026944-00)		<input checked="" type="checkbox"/> NB975 ■ 45x74.5x12mm, FPM (50-306557-50) <input checked="" type="checkbox"/> NB978 ■ 65x90x13mm, FPM (50-306307-00) <input checked="" type="checkbox"/> PA815 ■ (x1) 78x94x8mm (31-019993-30)			



MERCEDES-BENZ



KW/PS

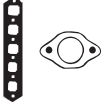

T2/LN1 508 D Diesel				03/89 → 12/94	248	BW370 (Fibre)	DW370	EM720
OM 601.941	2299	4	89.00		58-60/ 79-82	30-027217-20	21-27217-51/0 DW372 21-27217-53/0 DW373 (21-27217-54/0)	22-24895-01/0
T2/LN1 510				04/86 → 12/94	249	BH880 (Fibre)		
M 102.946	2299	4	95.50	Injection, SOHC	70/95	30-026005-10		
T2/LN1 507 D Diesel				04/86 → 04/89	250	BC790 (Fibre)	DC790	EC790
T2/LN1 507 DK Diesel				04/86 → 04/89		30-024065-10	21-24065-24/0	(22-26944-01/0) GC790 20-24065-01/0
OM 616.914	2399	4	90.90	SOHC	53/72			
Vaneo 1.6L (414)				02/02 →	251	AB5550 (MLS)	CB5550	EB5550
M 166.961	1598	4	80.00	Injection, SOHC	60-75/ 82-102	30-029326-00	21-29326-20/0	22-29326-00/0
Vaneo 1.7L CDI (414) Diesel				02/02 →	252	AB5560 (MLS), 1.20mm	CB5560	EB5560
OM 668.914	1689	4	80.00	Direct Injection	55-67/ 75-91	30-029329-00	21-29329-20/0	22-29329-00/0
Vaneo 1.9L (414)				02/02 →	253	AB5570 (MLS), 0.70mm	CB5570	EB5550
M 166.991	1898	4	84.00	Injection, SOHC	92/125		(21-29330-20/0)	22-29326-00/0
VARIO 512 D Diesel				09/96 →	254	BW380 (Fibre), 1.80mm	DW381	EN720
VARIO 612 D Diesel				09/96 →				
VARIO 812 D Diesel				09/96 →				
VARIO O 812 Diesel				09/96 →				
OM 602.984/OM 602.985	2874	5	89.00	SOHC	90/122	30-026270-20	21-28404-50/0	22-26946-01/0
V-Class V 200 (638/2)				02/97 → 07/03	255	BZ880 (Fibre)	DV810	EV810
M 111.948	1998	4	89.90		95/129	30-027462-10	21-27462-50/0	22-27311-50/0
V-Class V 200 CDI (638/2) Diesel				03/99 → 07/03	256	AC5620 (MLS), 1.20mm	CC5620	EC5620
V-Class V 220 CDI (638/2) Diesel				03/99 → 07/03				
OM 611.980	2151	4	88.00	Common Rail	85/115/ 116/ 156	30-029263-00	(21-29263-30/0)	22-29263-00/0
V-Class V 230 (638/2)				10/96 → 07/03	257	BZ900 (Fibre)	DZ160	EV810
M 111.978	2295	4	90.90	Injection, DOHC	105/143	30-027971-00	21-27971-50/0	22-27311-50/0

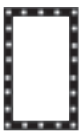
							
HBS058 ⊕ [22-26069B] M10x1.50x80mm (x4) M10x1.50x115mm (x5) M10x1.50x102mm (x9)	JD159 ■ 31-024911-00	JN572 [196] 50-026030-00 JN619 [195] 50-026031-00	JJ498 [31-026923-00]	HR757 ■ 24-30672-71/0	NA973 ■ 45x67x8mm, FPM (50-305910-50) NA975 ■ 45x74.5x12mm, FPM (50-306557-50) NA974 ■ 93x114x13mm, FPM (50-319192-00) NA5074 ■ [3] 93x133.5x15.5mm, PTFE (50-319396-00)	KK5683 [160]	
	JD292 ■ (x4) 31-026634-10	JN454 [195] 50-024959-10 JN607 [196] 50-025120-10	JJ488 [31-026812-00]	HR756 ■ 24-30615-70/0	NA973 ■ 45x67x8mm, FPM (50-305910-50) NA975 ■ 45x74.5x12mm, FPM (50-306557-50) NA974 ■ 93x114x13mm, FPM (50-319192-00) NA5074 ■ [3] 93x133.5x15.5mm, PTFE (50-319396-00)		
HBS045 ⊕ [22-26067B] M12x1.75x105mm (x4) M12x1.75x145mm (x6) M12x1.75x120mm (x8)	JB162 [31-024970-20]	JM848 50-022825-00	JH683 [31-026944-00]		NA975 ■ 45x74.5x12mm, FPM (50-306557-50) NA978 ■ 65x90x13mm, FPM (50-306307-00) PA815 ■ (x1) 78x94x8mm (31-019993-30)		
	JD5804 ■ (x4) 50-030212-00 JD5135 ■ [274] [31-029327-00]	JM5163 (50-029666-00)		HR5097 ■ 24-30614-74/0	NA5109 ■ 40x62x8mm, PTFE (50-319404-00) NA5107 ■ [3] 90x167x10.5mm, PTFE (50-319405-00)		
HBS291 ⊕ [22-26012B] M12x1.75x185mm (x10)	JD5834 ■ (x2) 50-030178-00 JD5136 ■ [31-029328-00]	JM5165 ■ (50-029668-00) JM5164 ■ (50-029667-00)	HR397 [57] 34-000410-00	HR5056 ■ 24-30704-41/0	NA5109 ■ 40x62x8mm, PTFE (50-319404-00) NA5107 ■ [3] 90x167x10.5mm, PTFE (50-319405-00)		
	JD5135 ■ [274] [31-029327-00]	JM5163 (50-029666-00)	HR397 [57] 34-000410-00	HR5097 ■ 24-30614-74/0	NA5109 ■ 40x62x8mm, PTFE (50-319404-00) NA5107 ■ [3] 90x167x10.5mm, PTFE (50-319405-00)		
HBS059 ⊕ [22-26006B] M10x1.50x80mm (x5) M10x1.50x115mm (x6) M10x1.50x102mm (x11)	JD298 ■ 31-025171-30 JD299 ■ 31-025172-00	JN621 [195] 50-026033-00 JN622 [196] 50-026032-00	JJ543 [31-026946-00]	HR758 ■ 24-30637-45/0	NA973 ■ 45x67x8mm, FPM (50-305910-50) NA975 ■ 45x74.5x12mm, FPM (50-306557-50) NA974 ■ 93x114x13mm, FPM (50-319192-00) NA5074 ■ [3] 93x133.5x15.5mm, PTFE (50-319396-00)		
HBS150 ⊕ [22-26009B] M12x1.75x102mm (x10)	JD160 ■ [31-027310-00] JD161 ■ 31-027309-10	JN911 50-027307-00 HM5057 ■ 24-27307-50/0	JH5082 [31-029265-00]	HR5085 ■ (x4)	NA973 ■ 45x67x8mm, FPM (50-305910-50) NA974 ■ 93x114x13mm, FPM (50-319192-00)		
HBS292 ⊕ [22-26011B] M12x1.75x102mm (x10)	JD5379 ■ (x4) (50-029976-00) (Rubber) JD5380 ■ [31-029977-00] (MLS)	HM5170 24-29264-00/0	JH5082 [6] [31-029265-00]	HR5085 ■ (x4)	NA5131 ■ 45x67x8mm, PTFE (50-319436-00) NA5074 ■ [3] 93x133.5x15.5mm, PTFE (50-319396-00)	KA5035 [13] KA5036 [13]	
HBS150 ⊕ [22-26009B] M12x1.75x102mm (x10)	JD160 ■ [31-027310-00] JD161 ■ 31-027309-10	HM5057 ■ 24-27307-50/0	JJ499 [31-027311-00]	HR5085 ■ (x4)	NA973 ■ 45x67x8mm, FPM (50-305910-50) NA974 ■ 93x114x13mm, FPM (50-319192-00)		

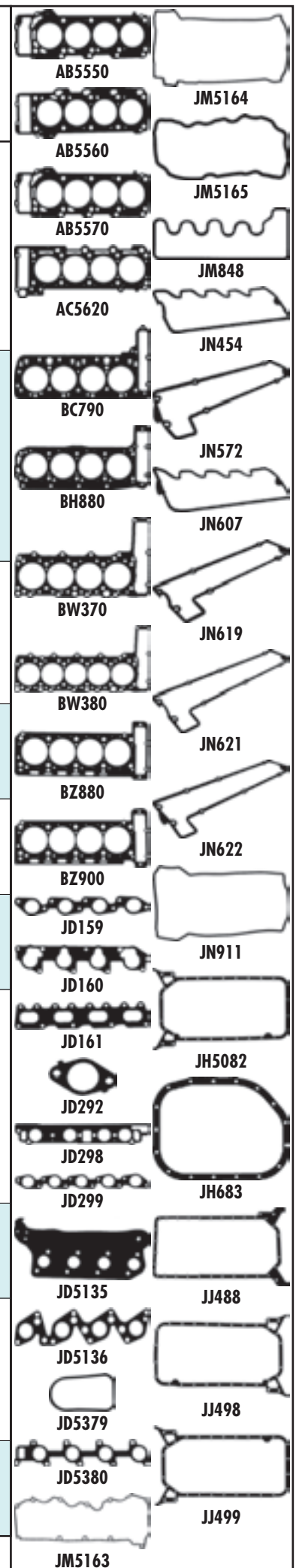







MERCEDES-BENZ

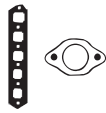

KW/PS

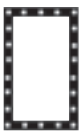

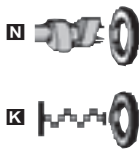
V-Class V 230 TD (638/2) Diesel		09/96 → 07/03		258	BW370 (Fibre)	DW370 <input type="checkbox"/> <input type="checkbox"/> <input type="checkbox"/>	EM720
OM 601A.970	2299	4	89.00	72/98	30-027217-20	21-27217-51/0	22-24895-01/0
V-Class V 280 (638/2)		08/97 → 07/03		259	AA5430 (Fibre)	CA5430	
M 104.900	3199	6	89.90	128/174	30-027920-00	21-27920-20/0	
Viano CDI 2.2 4-matic (W639) Diesel		07/05 →		260	AC5620 (MLS), 1.20mm	CC5620	EC5620
OM 646.982	2148	4	88.00	Direct Injection 80-110/ 109- 150	30-029263-00	(21-29263-30/0)	22-29263-00/0
Viano CDI (W639) Diesel		09/03 →		261	AC5620 (MLS), 1.20mm	CC5620	EC5620
OM 646.982	2148	4	88.00	Direct Injection 80-110/ 109- 150	30-029263-00	(21-29263-30/0)	22-29263-00/0
Viano CDI (W639) Diesel		09/03 →		262	AC5620 (MLS), 1.20mm	CC5620	EC5620
OM 646.982	2148	4	88.00	Direct Injection 80-110/ 109- 150	30-029263-00	(21-29263-30/0)	22-29263-00/0
Viano 3.2L (W639)		09/03 →		263	AE5750 (MLS) <input checked="" type="checkbox"/>		
M 112.951	3199	6	89.90	Injection, V6 140- 160/ 190- 218	30-029988-00 AE5760 (MLS) <input checked="" type="checkbox"/> 30-029989-00		
Viano 3.7L (W639)		06/04 →		264			
M 112.976	3724	6	97.00	Injection, V6 170/231			
Vito 113 (638)		02/96 → 07/03		265	BZ880 (Fibre)	DV810 <input type="checkbox"/> <input type="checkbox"/> <input type="checkbox"/>	EV810
M 111.948	1998	4	89.90	95/129	30-027462-10	21-27462-50/0	22-27311-50/0
Vito 108 CDI (638) Diesel		03/99 → 07/03		266	AC5620 (MLS), 1.20mm 30-029263-00	CC5620	EC5620
Vito 110 CDI (638) Diesel		03/99 → 07/03					
Vito 112 CDI (638) Diesel		03/99 → 07/03					
OM 611A (60 KW CDI)	2148	4	88.00	Direct Injection, DOHC 60/81			
OM 611LA (75 KW CDI)	2148	4	88.00	75-110/ 102- 150			
OM 611.980	2151	4	88.00	Common Rail 85/115/ 116/ 156			
Vito 109 CDI (W639) Diesel		09/03 →		267	AC5620 (MLS), 1.20mm 30-029263-00		EC5620
Vito 111 CDI (W639) Diesel		09/03 →					
Vito 115 CDI (W639) Diesel		09/03 →					
OM 646.983	2148	4	88.00	Direct Injection, DOHC 65/88			
OM 646.982	2148	4	88.00	Direct Injection 80-110/ 109- 150			22-29263-00/0

								
HBS058 Ⓞ (22-26069B) M10x1.50x80mm (x4) M10x1.50x115mm (x5) M10x1.50x102mm (x9)	JD158 ■ JD159 ■ 31-024911-00	JN572 50-026030-00		HR757 ■ 24-30672-71/0	NA973 ■ 45x67x8mm, FPM (50-305910-50) NA974 ■ 93x114x13mm, FPM (50-319192-00)	KK5683 [160]		AA5430 AC5620 AE5750 BW370
HBS077 Ⓞ (22-39012B) M11x1.50x85mm (x7) M11x1.50x144mm (x3) M11x1.50x119mm (x10)						KK5683 [160]		AE5750 BW370
HBS292 Ⓞ (22-26011B) M12x1.75x102mm (x10)	JD5379 ■ (x4) (50-029976-00) (Rubber) JD5380 ■ (31-029977-00) (MLS)		JH5082 [6] (31-029265-00)	HR5085 ■ (x4)	NA5131 ■ 45x67x8mm, PTFE (50-319436-00) NA5074 ■ [3] 93x133.5x15.5mm, PTFE (50-319396-00)	KA5035 [13] KA5036 [13]		BZ880 JD158 JD159 JD160
HBS292 Ⓞ (22-26011B) M12x1.75x102mm (x10)	JD5379 ■ (x4) (50-029976-00) (Rubber) JD5380 ■ (31-029977-00) (MLS)		JH5082 [6] (31-029265-00)	HR5085 ■ (x4)	NA5131 ■ 45x67x8mm, PTFE (50-319436-00) NA5074 ■ [3] 93x133.5x15.5mm, PTFE (50-319396-00)	KA5035 [13] KA5036 [13]		JD161 JD5379 JD5380
HBS292 Ⓞ (22-26011B) M12x1.75x102mm (x10)	JD5379 ■ (x4) (50-029976-00) (Rubber) JD5380 ■ (31-029977-00) (MLS)		JH5082 [6] (31-029265-00)	HR5085 ■ (x4)	NA5131 ■ 45x67x8mm, PTFE (50-319436-00) NA5074 ■ [3] 93x133.5x15.5mm, PTFE (50-319396-00)	KA5035 [13] KA5036 [13]		JD161 JD5379 JD5380
HBS463 (x2) (22-26020B) M11x1.5x141mm (x8)	JD5385 ■ (x2) (31-029992-00) JD5386 ■ (x6) (31-029993-00)	JM5236 ■ (50-029990-00) JM5237 ■ (50-029991-00)	HR397 [6] 34-000410-00		NA5131 ■ 45x67x8mm, PTFE (50-319436-00) NA5168 ■ 93x114x11.5mm, PTFE (50-319437-00)	KA5035 [13] KA5036 [13]		JD5385 JD5386
HBS463 (x2) (22-26020B) M11x1.5x141mm (x8)	JD5385 ■ (x2) (31-029992-00) JD5386 ■ (x6) (31-029993-00)	JM5236 ■ (50-029990-00) JM5237 ■ (50-029991-00)	HR397 [57] 34-000410-00		NA5131 ■ 45x67x8mm, PTFE (50-319436-00) NA5168 ■ 93x114x11.5mm, PTFE (50-319437-00)			JN572
HBS150 Ⓞ (22-26009B) M12x1.75x102mm (x10)	JD160 ■ (31-027310-00) JD161 ■ 31-027309-10	JN911 50-027307-00 HM5057 ■ 24-27307-50/0	JH5082 (31-029265-00)	HR5085 ■ (x4)	NA973 ■ 45x67x8mm, FPM (50-305910-50) NA974 ■ 93x114x13mm, FPM (50-319192-00)			JN911
HBS292 Ⓞ (22-26011B) M12x1.75x102mm (x10)	JD5379 ■ (x4) (50-029976-00) (Rubber) JD5380 ■ (31-029977-00) (MLS)	HM5170 24-29264-00/0	JH5082 [6] (31-029265-00)	HR5085 ■ (x4)	NA5131 ■ 45x67x8mm, PTFE (50-319436-00) NA5074 ■ [3] 93x133.5x15.5mm, PTFE (50-319396-00)	KA5035 [13] KA5036 [13]		JH5082
HBS292 Ⓞ (22-26011B) M12x1.75x102mm (x10)	JD5379 ■ (x4) (50-029976-00) (Rubber) JD5380 ■ (31-029977-00) (MLS)		JH5082 [6] (31-029265-00)	HR5085 ■ (x4)	NA5131 ■ 45x67x8mm, PTFE (50-319436-00) NA5074 ■ [3] 93x133.5x15.5mm, PTFE (50-319396-00)	KA5035 [13] KA5036 [13]		







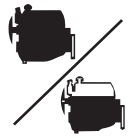



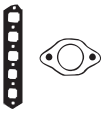

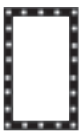

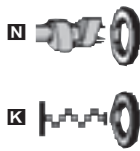



































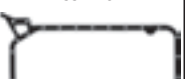







MERCEDES-BENZ



KW/PS



Vito 108 D (638) Diesel					02/96 → 07/03	268	BW370 (Fibre) 30-027217-20	DW370 <input type="checkbox"/> <input checked="" type="checkbox"/> <input type="checkbox"/> <input type="checkbox"/> 21-27217-51/0	EM720 22-24895-01/0
Vito 110 D (638) Diesel					03/97 → 07/03				
Vito 110 TD (638) Diesel					02/96 → 07/03				
OM 601.942	2299	4	89.00		58/79				
OM 601A.970	2299	4	89.00		72/98				
Vito 114 (638)					12/96 → 07/03	269	BZ900 (Fibre) 30-027971-00	DZ160 <input type="checkbox"/> <input type="checkbox"/> <input type="checkbox"/> <input type="checkbox"/> 21-27971-50/0	EV810 22-27311-50/0
M 111.978	2295	4	90.90	Injection, DOHC	105/143				
Vito 119 (W639)					09/03 →	270	AE5750 (MLS) <input checked="" type="checkbox"/> 30-029988-00		
M 112.951	3199	6	89.90	Injection, V6	140- 160/ 190- 218				
Vito 119 (W639)					09/03 →	271	AE5750 (MLS) <input checked="" type="checkbox"/> 30-029988-00		
Vito 122 (W639)					09/03 →				
M 112.951	3199	6	89.90	Injection, V6	140- 160/ 190- 218				
Vito 123 (W639)					06/04 →	272			
M 112.976	3724	6	97.00	Injection, V6	170/231				

								
HBS058  [22-26069B] M10x1.50x80mm (x4) M10x1.50x115mm (x5) M10x1.50x102mm (x9)	JD158  JD159  31-024911-00	JN572 [196] 50-026030-00 JN619 [195] 50-026031-00	JJ498 (31-026923-00)	HR757  24-30672-71/0	NB973  45x67x8mm, FPM (50-305910-50) NB974  93x114x13mm, FPM (50-319192-00)	KK5683 [160]	 AE5750  JN572  BW370  JN619  BZ900  JM5111 (x4) [119]	
HBS150  [22-26009B] M12x1.75x102mm (x10)	JD160  (31-027310-00) JD161  31-027309-10	JN911 50-027307-00 HM5057  24-27307-50/0	JJ499 (31-027311-00)	HR5085  (x4)	NB973  45x67x8mm, FPM (50-305910-50) NB974  93x114x13mm, FPM (50-319192-00)	JM5111 (x4) [119]	 JD158  JD159  JH5082  JD160  JM5111 (x4) [119]	
HBS463 (x2) [22-26020B] M11x1.5x141mm (x8)	JD5385  (x2) (31-029992-00) JD5386  (x6) (31-029993-00)	JM5236  (50-029990-00) JM5237  (50-029991-00)	HR397 [57] 34-000410-00		NA5131  45x67x8mm, PTFE (50-319436-00) NA5168  93x114x11.5mm, PTFE (50-319437-00)	NA5248 [2] 	 JD161  JJ498  JD5385  JD5386  JM5236  JM5237	
HBS463 (x2) [22-26020B] M11x1.5x141mm (x8)	JD5385  (x2) (31-029992-00) JD5386  (x6) (31-029993-00)	JM5236  (50-029990-00) JM5237  (50-029991-00)	HR397 [57] 34-000410-00		NA5131  45x67x8mm, PTFE (50-319436-00) NA5168  93x114x11.5mm, PTFE (50-319437-00)	NA5248 [2] 	 JM5236  JM5237	
HBS463 (x2) [22-26020B] M11x1.5x141mm (x8)	JD5385  (x2) (31-029992-00) JD5386  (x6) (31-029993-00)	JM5236  (50-029990-00) JM5237  (50-029991-00)	HR397 [57] 34-000410-00		NA5131  45x67x8mm, PTFE (50-319436-00) NA5168  93x114x11.5mm, PTFE (50-319437-00)		 JM5236  JM5237	



CC



9



CC



9

14 K4F	Petrol	1396	4	74.97	7
1500	Petrol	1493	4	73.64	30
16 AMW	Petrol	1622	4	76.18	21
16 GE	Petrol	1622	4	76.18	21
16 K4F	Petrol	1589	4	80.00	11
16 K4F	Petrol	1589	4	80.00	24
16 K4F	Petrol	1589	4	80.00	4
16 RA	Petrol	1622	4	76.18	21
18 K4F	Petrol	1796	4	80.00	12
18 K4F	Petrol	1796	4	80.00	15
18 K4F	Petrol	1796	4	80.00	26
18 K4F	Petrol	1796	4	80.00	5
18 K4F	Petrol	1796	4	80.00	8
18 K4K (VVC)	Petrol	1796	4	80.00	25
18 K4K (VVC)	Petrol	1796	4	80.00	6
18 K4K (VVC)	Petrol	1796	4	80.00	9
20 H - O Series	Petrol	1994	4	84.44	1
20 H - O Series	Petrol	1994	4	84.44	31
20 K4F	Petrol	1997	6	80.00	17
20 T2N (L Series)	Diesel	1994	4	84.45	10
20 T2N (L Series)	Diesel	1994	4	84.45	13
204D2	Diesel	1951	4	84.00	18
25 K4F	Petrol	2497	6	80.00	14
25 K4F	Petrol	2497	6	80.00	20
3.5V8	Petrol	3528	8	88.86	23
A Series	Petrol	948	4	62.92	27
A Series	Petrol	1098	4	64.56	28
A Series	Petrol	1275	4	70.62	29
A+ Series	Petrol	1275	4	70.62	3
B Series	Petrol	1588	4	75.39	21
B Series	Petrol	1798	4	80.25	22
HC	Petrol	1275	4	70.62	2
M 47D 20R	Diesel	1951	4	84.00	19

MG



KW/PS



Maestro 2.0L EFi					10/84 → 09/90	1	BN670 (Fibre)	DN671 01/86 → 12/88 DN676 01/88 →	EM684 1986 →
20 H - 0 Series	1994	4	84.44	SOHC		86/117			
Metro 1.3L Turbo					10/82 → 09/90	2	AF470 (Fibre) [122] (30-027571-00) BK450 (Fibre) [123]	DK451 [123]	EF464 [124]
HC	1275	4	70.62	Carburettor		69/94			
Metro 1300					05/82 → 09/90	3	AF470 (Fibre) [122] (30-027571-00) BK450 (Fibre) [123]	CF474 [122] DK450 [123]	EF464 [124]
A+ Series	1275	4	70.62	Carburettor		54/73			
MG TF Convertible 115					03/02 →	4	BW5750 (MLS) [246] (30-030305-00) BW750 (Steel Elastomer) (30-029292-00) KM5001 [190] (40-029292-00)	DW5757 [247] (21-30305-00/0) DW757 (21-29292-24/0)	ER322 (22-29294-01/0)
16 K4F	1589	4	80.00	MPi, DOHC		85/110			
MG TF Convertible 120					03/02 →	5	BW5750 (MLS) [246] (30-030305-00) BW750 (Steel Elastomer) (30-029292-00) KM5001 [190] (40-029292-00)	DW5757 [247] (21-30305-00/0) DW757 (21-29292-24/0)	ER322 (22-29294-01/0)
MG TF Convertible 135					03/02 →				
18 K4F	1796	4	80.00	Injection, DOHC		88/120			
MG TF Convertible 160					03/02 →	6	BW5750 (MLS) [246] (30-030305-00) BW750 (Steel Elastomer) (30-029292-00) KM5001 [190] (40-029292-00)	DW754 (21-29292-21/0)	ER322 (22-29294-01/0)
18 K4K (VVC)	1796	4	80.00	MPi, DOHC		107- 118/ 146- 160			

		JC435 01/86→12/88		JJ315	HR625	<input checked="" type="checkbox"/> NB775 40x52x7mm, FPM 1985→ <input checked="" type="checkbox"/> NB773 46x60x7mm, FPM 1985→ <input checked="" type="checkbox"/> NB586 30x40x7mm, MVQ →12/85 <input checked="" type="checkbox"/> NB772 88.9x104.8x9.52mm, MVQ <input checked="" type="checkbox"/> NB774 35x45x7mm, FPM (50-319419-00) 1985→			AF470 BK450 BN670 BW5750 BW750 JA439 JC435 JR264 JC852 JD311 JD563 JD564 JM302 JN963 HC031 JJ315	
			JM302 (31-027568-00)	HC031	HR339 (x2)	<input checked="" type="checkbox"/> NA473 39.7x59x9.5mm, NBR <input checked="" type="checkbox"/> NA584 55x70x10mm, MVQ	<input checked="" type="checkbox"/> NA448 [2] <input checked="" type="checkbox"/> NA301 [2] <input checked="" type="checkbox"/> NB684 [38] <input checked="" type="checkbox"/> HJ013 [39] <input checked="" type="checkbox"/> NB083 [42] [120] <input checked="" type="checkbox"/> JR264 [11] [124]			
		JA439	JM302 (31-027568-00)	HC031	HR339 (x2)	<input checked="" type="checkbox"/> NA473 39.7x59x9.5mm, NBR <input checked="" type="checkbox"/> NA584 55x70x10mm, MVQ	<input checked="" type="checkbox"/> NA448 [2] <input checked="" type="checkbox"/> NA301 [2] <input checked="" type="checkbox"/> NB684 [38] <input checked="" type="checkbox"/> HJ013 [39] <input checked="" type="checkbox"/> NB083 [42] [120] <input checked="" type="checkbox"/> JR264 [11] [124]			
HBS005 (22-89005B) M9x1.25x412mm (x10)	JD311 [192] (50-029305-00) (FPM) JC852 (31-029304-00)	JN963 (31-029297-00)			HR752 (24-31939-80/0)	<input checked="" type="checkbox"/> NC065 (x2) 30x40x7mm, FPM (50-306142-00) Black <input checked="" type="checkbox"/> NB998 (x2) 30x40x7mm, FPM (50-319402-00) Brown <input checked="" type="checkbox"/> NB828 27.5x39.5x7mm, FPM (50-319399-00) <input checked="" type="checkbox"/> NB829 79.95x116x11.5mm, FPM (50-319400-00)				
HBS005 (22-89005B) M9x1.25x412mm (x10)	JD311 [192] (50-029305-00) (FPM) JC852 (31-029304-00)	JN963 (31-029297-00)			HR752 (24-31939-80/0)	<input checked="" type="checkbox"/> NC065 (x2) 30x40x7mm, FPM (50-306142-00) Black <input checked="" type="checkbox"/> NB998 (x2) 30x40x7mm, FPM (50-319402-00) Brown <input checked="" type="checkbox"/> NB828 27.5x39.5x7mm, FPM (50-319399-00) <input checked="" type="checkbox"/> NB829 79.95x116x11.5mm, FPM (50-319400-00)				
HBS005 (22-89005B) M9x1.25x412mm (x10)	JD564 [192] (31-029307-00) JD563 [192] (31-029306-00) JC852 (31-029304-00)	JN963 (31-029297-00)			HR752 (24-31939-80/0)	<input checked="" type="checkbox"/> NC065 (x2) 30x40x7mm, FPM (50-306142-00) Black <input checked="" type="checkbox"/> NB998 (x2) 30x40x7mm, FPM (50-319402-00) Brown <input checked="" type="checkbox"/> NB828 27.5x39.5x7mm, FPM (50-319399-00) <input checked="" type="checkbox"/> NB829 79.95x116x11.5mm, FPM (50-319400-00)				







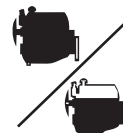



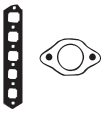

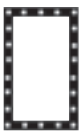

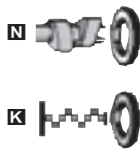



MG



KWPS

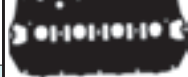

MG ZR 105					06/01 →	7		
14 K4F	1396	4	74.97	MPi, DOHC	76/103	BW5750 (MLS) [246] (30-030305-00) BW750 (Steel Elastomer) (30-029292-00) KM5001 [190] (40-029292-00)	DW5757 [247] (21-30305-00/0) DW757 (21-29292-24/0)	ER321 [201] (22-29294-00/0)
MG ZR 120					06/01 →	8		
18 K4F	1796	4	80.00	Injection, DOHC	88/120	BW5750 (MLS) [246] (30-030305-00) BW750 (Steel Elastomer) (30-029292-00) KM5001 [190] (40-029292-00)	DW5757 [247] (21-30305-00/0) DW757 (21-29292-24/0)	ER322 (22-29294-01/0)
MG ZR 160					06/01 →	9		
18 K4K (VVC)	1796	4	80.00	MPi, DOHC	107- 118/ 146- 160	BW5750 (MLS) [246] (30-030305-00) BW750 (Steel Elastomer) (30-029292-00) KM5001 [190] (40-029292-00)	DW754 (21-29292-21/0)	ER322 (22-29294-01/0)
MG ZR 2.0L CDTi Diesel					06/01 →	10		
20 T2N (L Series)	1994	4	84.45	EFi, Turbo Intercooled	74/100	BZ440 (MLS), 1.05mm, 1 Hole (30-029569-00) BZ450 (MLS), 1.20mm, 2 Holes (30-029570-00) BZ460 (MLS), 1.35mm, 3 Holes (30-029571-00)	DZ440▲ (21-29569-20/0)	EZ441 [12] (22-29569-01/0)
MG ZS 110					07/01 →	11		
16 K4F	1589	4	80.00	MPi, DOHC	85/110	BW5750 (MLS) [246] (30-030305-00) BW750 (Steel Elastomer) (30-029292-00) KM5001 [190] (40-029292-00)	DW5757 [247] (21-30305-00/0) DW757 (21-29292-24/0)	ER322 (22-29294-01/0)
MG ZS 120					07/01 →	12		
18 K4F	1796	4	80.00	Injection, DOHC	86/117	BW5750 (MLS) [246] (30-030305-00) BW750 (Steel Elastomer) (30-029292-00) KM5001 [190] (40-029292-00)	DW5757 [247] (21-30305-00/0) DW757 (21-29292-24/0)	ER322 (22-29294-01/0)
18 K4F	1796	4	80.00		88/120			









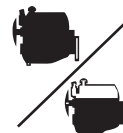

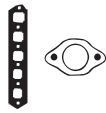

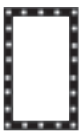

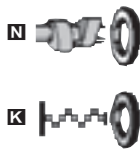





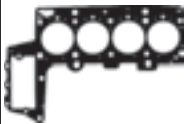

















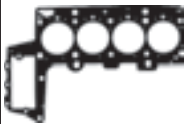

















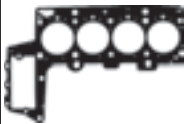

















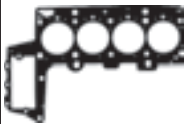

















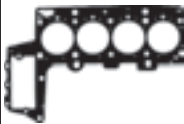

















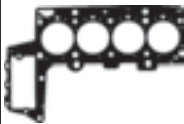

















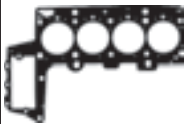



								 BW5750
HBS005 ® (22-89005B) M9x1.25x412mm (x10)	JD311 [192] (50-029305-00) (FPM) JC852 ® (31-029304-00)	JN963 (31-029297-00)	JH5016 [201] (50-029294-00)	HR752 ® (24-31939-80/0)	NCO65 ® (x2) 30x40x7mm, FPM (50-306142-00) Black NB998 ® (x2) 30x40x7mm, FPM (50-319402-00) Brown NB828 ® 27.5x39.5x7mm, FPM (50-319399-00) NB829 ® 79.95x116x11.5mm, FPM (50-319400-00)			 BW750  BZ440, BZ450, BZ460  JC852  JD311
HBS005 ® (22-89005B) M9x1.25x412mm (x10)	JD311 [192] (50-029305-00) (FPM) JC852 ® (31-029304-00)	JN963 (31-029297-00)		HR752 ® (24-31939-80/0)	NCO65 ® (x2) 30x40x7mm, FPM (50-306142-00) Black NB998 ® (x2) 30x40x7mm, FPM (50-319402-00) Brown NB828 ® 27.5x39.5x7mm, FPM (50-319399-00) NB829 ® 79.95x116x11.5mm, FPM (50-319400-00)			 JD563  JD564  JD657  JN963
HBS005 ® (22-89005B) M9x1.25x412mm (x10)	JD564 [192] (31-029307-00) JD563 [192] (31-029306-00) JC852 ® (31-029304-00)	JN963 (31-029297-00)		HR752 ® (24-31939-80/0)	NCO65 ® (x2) 30x40x7mm, FPM (50-306142-00) Black NB998 ® (x2) 30x40x7mm, FPM (50-319402-00) Brown NB828 ® 27.5x39.5x7mm, FPM (50-319399-00) NB829 ® 79.95x116x11.5mm, FPM (50-319400-00)			 JP097  JH5012
HBS282 ® (22-72002B) M11x1.50x230mm (x10)	JD657	JP097	JH5012	HR5051 ®	NB775 (x2) 40x52x7mm, FPM NB774 ® 35x45x7mm, FPM (50-319419-00) LK5002 ® [3] 136x153x21mm, PTFE (50-319427-00)			 JH5016
HBS005 ® (22-89005B) M9x1.25x412mm (x10)	JD311 [192] (50-029305-00) (FPM) JC852 ® (31-029304-00)	JN963 (31-029297-00)		HR752 ® (24-31939-80/0)	NCO65 ® (x2) 30x40x7mm, FPM (50-306142-00) Black NB998 ® (x2) 30x40x7mm, FPM (50-319402-00) Brown NB828 ® 27.5x39.5x7mm, FPM (50-319399-00) NB829 ® 79.95x116x11.5mm, FPM (50-319400-00)			
HBS005 ® (22-89005B) M9x1.25x412mm (x10)	JD311 [192] (50-029305-00) (FPM) JC852 ® (31-029304-00)	JN963 (31-029297-00)		HR752 ® (24-31939-80/0)	NCO65 ® (x2) 30x40x7mm, FPM (50-306142-00) Black NB998 ® (x2) 30x40x7mm, FPM (50-319402-00) Brown NB828 ® 27.5x39.5x7mm, FPM (50-319399-00) NB829 ® 79.95x116x11.5mm, FPM (50-319400-00)			

MG



KW/PS



								
		JD657	JP097	JH5012	HR5051	NB775 (x2) 40x52x7mm, FPM NB774 35x45x7mm, FPM (50-319419-00) LK5002 [3] 136x153x21mm, PTFE (50-319427-00)		 AA5920  BW5750  BW750  BZ440, BZ450, BZ460  BZ690, BZ700, BZ710  JA5078  JA5079  JC852  JD311  JD5183  JD657  JM5035  JM5076  JN963  JP097  JH5012  JH5032  JH5033
HBS423 [22-89009B] M9x1.25x200mm (x16)	JA5079 (x2) (31-029413-00) JA5078 (x2) (31-029412-00)	JM5035 (x2) (31-029414-00)		HR5031 (x2) (24-31939-81/0)	NC065 (x2) 30x40x7mm, FPM (50-306142-00) Black NB998 (x4) 30x40x7mm, FPM (50-319402-00) Brown NA5083 32.5x45x7.7mm, FPM (50-319423-00) LK5000 [3] 89x116x10.2mm, FPM (50-319424-00)			 AA5920  BW5750  BW750  BZ440, BZ450, BZ460  BZ690, BZ700, BZ710  JA5078  JA5079  JC852  JD311  JD5183  JD657  JM5035  JM5076  JN963  JP097  JH5012  JH5032  JH5033
HBS005 [22-89005B] M9x1.25x412mm (x10)	JD311 [192] (50-029305-00) (FPM) JC852 (31-029304-00)	JN963 (31-029297-00)		HR752 (24-31939-80/0)	NC065 (x2) 30x40x7mm, FPM (50-306142-00) Black NB998 (x2) 30x40x7mm, FPM (50-319402-00) Brown NB828 27.5x39.5x7mm, FPM (50-319399-00) NB829 79.95x116x11.5mm, FPM (50-319400-00)			 AA5920  BW5750  BW750  BZ440, BZ450, BZ460  BZ690, BZ700, BZ710  JA5078  JA5079  JC852  JD311  JD5183  JD657  JM5035  JM5076  JN963  JP097  JH5012  JH5032  JH5033
HBS005 [22-89005B] M9x1.25x412mm (x10)								
HBS423 [22-89009B] M9x1.25x200mm (x16)	JA5079 (x2) (31-029413-00) JA5078 (x2) (31-029412-00)	JM5035 (x2) (31-029414-00)		HR5031 (x2) (24-31939-81/0)	NC065 (x2) 30x40x7mm, FPM (50-306142-00) Black NB998 (x4) 30x40x7mm, FPM (50-319402-00) Brown NA5083 32.5x45x7.7mm, FPM (50-319423-00) LK5000 [3] 89x116x10.2mm, FPM (50-319424-00)			 AA5920  BW5750  BW750  BZ440, BZ450, BZ460  BZ690, BZ700, BZ710  JA5078  JA5079  JC852  JD311  JD5183  JD657  JM5035  JM5076  JN963  JP097  JH5012  JH5032  JH5033
HBS121 [22-11006B] M12x1.50x146.5mm (x10)	HA5006 (x2) (24-29152-00/0)	JM5076 (50-029456-00)	JH5032 (31-029457-00) JH5033 (31-029458-00)	HR5045 24-30724-07/0	NA5103 55x68x8mm, PTFE (50-319391-00) NA5104 90x110x12mm, PTFE (50-319389-00)			 AA5920  BW5750  BW750  BZ440, BZ450, BZ460  BZ690, BZ700, BZ710  JA5078  JA5079  JC852  JD311  JD5183  JD657  JM5035  JM5076  JN963  JP097  JH5012  JH5032  JH5033
HBS121 [22-11006B] M12x1.50x146.5mm (x10)	HA5006 (x2) (24-29152-00/0) JD5183 (x2) (31-029124-00)	JM5076 (50-029456-00)	JH5032 (31-029457-00) JH5033 (31-029458-00)	HR5045 24-30724-07/0	NA5103 55x68x8mm, PTFE (50-319391-00) NA5104 90x110x12mm, PTFE (50-319389-00)			 AA5920  BW5750  BW750  BZ440, BZ450, BZ460  BZ690, BZ700, BZ710  JA5078  JA5079  JC852  JD311  JD5183  JD657  JM5035  JM5076  JN963  JP097  JH5012  JH5032  JH5033
HBS423 [22-89009B] M9x1.25x200mm (x16)	JA5079 (x2) (31-029413-00) JA5078 (x2) (31-029412-00)	JM5035 (x2) (31-029414-00)		HR5031 (x2) (24-31939-81/0)	NC065 (x2) 30x40x7mm, FPM (50-306142-00) Black NB998 (x4) 30x40x7mm, FPM (50-319402-00) Brown NA5083 32.5x45x7.7mm, FPM (50-319423-00) LK5000 [3] 89x116x10.2mm, FPM (50-319424-00)			 AA5920  BW5750  BW750  BZ440, BZ450, BZ460  BZ690, BZ700, BZ710  JA5078  JA5079  JC852  JD311  JD5183  JD657  JM5035  JM5076  JN963  JP097  JH5012  JH5032  JH5033







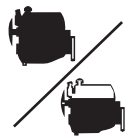



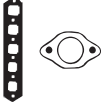

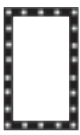
MG



KW/PS

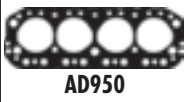
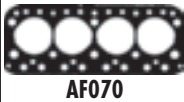

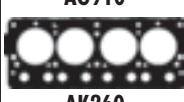
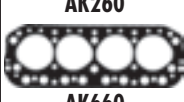
MGA 1600					01/59 → 12/61	21	AD950 (Fibre) [121]	CD950■	
MGA 1600 Mk II					01/61 → 12/62				
B Series	1588	4	75.39	B Series, Carburettor					
16 AMW/16 GE/16 RA	1622	4	76.18	B Series, Carburettor					
MGB Coupe 1.8L					01/66 → 11/80	22	AK660 (Fibre), (Steel) (30-027581-00)	CK664■ [240] [241] CK665■ Canada USA	EG411
B Series	1798	4	80.25		68/92				
MGB Coupe 3.5L					01/73 → 12/76	23	AB5480 (Fibre) (x2) [188] AG910 (Steel) (x2)	CG914■	EG914
3.5V8	3528	8	88.86		101/137				
MGF 1.6L					09/01 → 01/02	24	BW5750 (MLS) [246] (30-030305-00) BW750 (Steel Elastomer) (30-029292-00) KM5001 [190] (40-029292-00)	DW5757 [247] (21-30305-00/0) DW757 (21-29292-24/0)	ER322 (22-29294-01/0)
MGF Convertible 1.6L					02/00 → 03/02				
16 K4F	1589	4	80.00	MPi, DOHC	85/110				
MGF 1.8 i VVC					10/01 → 03/02	25	BW5750 (MLS) [246] (30-030305-00) BW750 (Steel Elastomer) (30-029292-00) KM5001 [190] (40-029292-00)	DW754 (21-29292-21/0)	ER322 (22-29294-01/0)
MGF Convertible 1.8L i VVC					03/95 → 03/02				
18 K4K (VVC)	1796	4	80.00	MPi, DOHC	107- 118/ 146- 160 118/160				
18 K4K (VVC)	1796	4	80.00						
MGF Convertible 1.8L i 16V					03/95 → 03/02	26	BW5750 (MLS) [246] (30-030305-00) BW750 (Steel Elastomer) (30-029292-00) KM5001 [190] (40-029292-00)	DW5757 [247] (21-30305-00/0) DW757 (21-29292-24/0)	ER322 (22-29294-01/0)
18 K4F	1796	4	80.00	Injection, DOHC	88/120				
Midget Mk I					01/61 → 12/66	27	AF070 (Fibre) [121] (30-027570-00)	CF070■	EF070 → Eng.10CC/DA/H37548 → Eng.10CC/DA/L25599 EF074 Eng.10CC/DA/H37549 → Eng.10CC/DA/L25600 →
Midget Mk II					01/61 → 12/66				
A Series	948	4	62.92	Carburettor					
Midget Convertible 1.1L					01/64 → 12/66	28	AF070 (Fibre) [121] (30-027570-00)	CF070■	EF075 [125]
A Series	1098	4	64.56		41/56				
Midget Convertible 1.3L					01/67 → 09/74	29	AF460 (Fibre) [121] (30-027582-00) AF470 (Fibre) [122] (30-027571-00)	CF463■ [121] CF473■ [122]	EF460
A Series	1275	4	70.62		48/65				
Midget Convertible 1.5L					09/74 → 12/79	30	AK260 (Fibre) [249]	CK262■○	EG091 [12]
1500	1493	4	73.64		49/66				

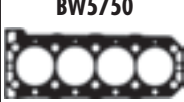
								
		JA282	JM315		HR618 [193]	NA473 39.7x59x9.5mm, NBR		 AB5480
		JA282 [240] [241] JE241 (x2)	JM315 KT005 (x2) [126]	JH396	HR618 [193]	NA473 39.7x59x9.5mm, NBR NB772 88.9x104.8x9.52mm, MVQ	NA448 [2] NA294 [2]	 JM483
		JE241 (x2)	JM483 (x2) (31-029717-00)	JH434	HR5052	NB849 48.7x63.5x8mm, FPM (50-319467-00) NB291 82.6x98.7x12.7mm, MVQ	NA448 [2] NA294 [2]	 AD950
HBS005 [22-89005B] M9x1.25x412mm (x10)	JD311 [192] (50-029305-00) (FPM) JC852 (31-029304-00)	JN963 (31-029297-00)		HR752 (24-31939-80/0)	NCO65 (x2) 30x40x7mm, FPM (50-306142-00) Black NB998 (x2) 30x40x7mm, FPM (50-319402-00) Brown NB828 27.5x39.5x7mm, FPM (50-319399-00) NB829 79.95x116x11.5mm, FPM (50-319400-00)			 AF70
HBS005 [22-89005B] M9x1.25x412mm (x10)	JD564 [31-029307-00] JD563 [31-029306-00] JC852 (31-029304-00)	JN963 (31-029297-00)		HR752 (24-31939-80/0)	NCO65 (x2) 30x40x7mm, FPM (50-306142-00) Black NB998 (x2) 30x40x7mm, FPM (50-319402-00) Brown NB828 27.5x39.5x7mm, FPM (50-319399-00) NB829 79.95x116x11.5mm, FPM (50-319400-00)			 AF460, AF470
HBS005 [22-89005B] M9x1.25x412mm (x10)	JD311 [192] (50-029305-00) (FPM) JC852 (31-029304-00)	JN963 (31-029297-00)		HR752 (24-31939-80/0)	NCO65 (x2) 30x40x7mm, FPM (50-306142-00) Black NB998 (x2) 30x40x7mm, FPM (50-319402-00) Brown NB828 27.5x39.5x7mm, FPM (50-319399-00) NB829 79.95x116x11.5mm, FPM (50-319400-00)			 AG910
	JA439	JM302 (31-027568-00) KT005 (x2) [126]	HC048	HR619	NA473 39.7x59x9.5mm, NBR	NA301 [2]		 AK260
	JA439	JM302 (31-027568-00) KT005 (x2) [126]	HC031	HR619	NA473 39.7x59x9.5mm, NBR NA584 55x70x10mm, MVQ	NB684 [38] HJ013 [39] NB083 [42] [120]		 AK660
	JA439 JE241	JM302 (31-027568-00)	HC063	HR339 (x2)	NA473 39.7x59x9.5mm, NBR	NA301 [2]		 BW5750
	JB765 JE331 →Ch.Y25000	JM261	JH445		NA774 73x92.1x9.5mm, MVQ			 BW750

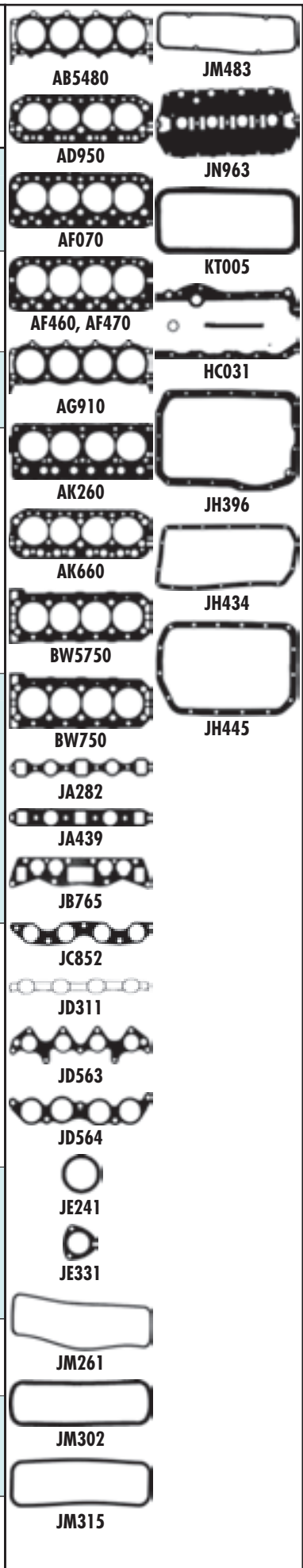

MG



KW/PS

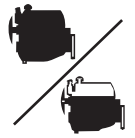

Montego 2.0L EFI

04/84 → 09/90

31

BN670 (Fibre)

DN671

01/86 → 12/88

DN676

01/88 →

 EM684

1986 →









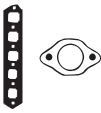

20 H - 0 Series

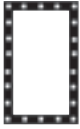
1994

4

84.44

86/117

					 		 <p>BN670</p>  <p>JC435</p>  <p>JJ315</p>
	<p>JC435 01/86→12/88</p>		<p>JJ315</p>	<p>HR625</p>	<p><input checked="" type="checkbox"/> NB775 40x52x7mm, FPM 1985→</p> <p><input checked="" type="checkbox"/> NB773 46x60x7mm, FPM 1985→</p> <p><input checked="" type="checkbox"/> NB586 30x40x7mm, MVQ →12/85</p> <p><input checked="" type="checkbox"/> NB772 88.9x104.8x9.52mm, MVQ</p> <p><input checked="" type="checkbox"/> NB774 35x45x7mm, FPM (50-319419-00) 1985→</p>		

MINI



KW/PS

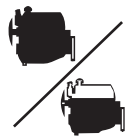

Mini One D Diesel		06/03 →		1				
1ND	1364	4	73.00	Direct Injection	55/75	AG7600 (MLS), 0.85mm →09/05 AG7610 (MLS), 0.90mm →09/05 AG7620 (MLS), 0.95mm →09/05	CG7600▲	FG7600▲
Mini Cabriolet Works		07/04 →		2				
W11B16A	1598	4	77.00		120/ 125/ 163/ 170	AC5920 (MLS), 0.65mm (30-029488-00)		
Mini Clubman 1.6L D Diesel		10/07 →		3				
9HZ (DV6TED4)	1560	4	75.00	Direct Injection, DOHC	80/109	AD5130 (MLS), 1.25mm, 2 Notches, +3 Notches (30-029277-00) AD5140 (MLS), 1.30mm, 3 Notches, +3 Notches (30-029278-00) AD5150 (MLS), 1.35mm, 1 Notch, +3 Notches (30-029279-00) AD5160 (MLS), 1.40mm, +3 Notches, 4 Notches (30-029280-00) AD5170 (MLS), 1.45mm, +3 Notches, 5 Notches (30-029281-00)	CD5140▲ (21-29278-00/0)	
Mini Convertible Cooper		07/04 →		4				
Mini Convertible One		07/04 →				AC5920 (MLS), 0.65mm (30-029488-00)	CC5920 (21-29489-20/0)	
W10B16A	1598	4	77.00		66/85/ 90/116			
Mini Convertible Cooper S		07/04 →		5				
W11B16A	1598	4	77.00		120/ 125/ 163/ 170	AC5920 (MLS), 0.65mm (30-029488-00)	CC5921■ 21-29489-21/0	
Mini Cooper		06/01 →		6				
Mini One		06/01 →				AC5920 (MLS), 0.65mm (30-029488-00)	CC5920 (21-29489-20/0)	EC5921 (22-29488-01/0) →07/04
W10B16A	1598	4	77.00		66/85/ 90/116			
Mini Cooper S		03/02 →		7				
W11B16A	1598	4	77.00		120/ 125/ 163/ 170	AC5920 (MLS), 0.65mm (30-029488-00)	CC5921■ 21-29489-21/0 →07/04	EC5921 (22-29488-01/0) →07/04
Mini Cooper S		07/04 →		8				
Mini Works		11/03 →				AC5920 (MLS), 0.65mm (30-029488-00)	CC5921■ 21-29489-21/0	EC5921 (22-29488-01/0) →07/04
W11B16A	1598	4	77.00		120/ 125/ 163/ 170			

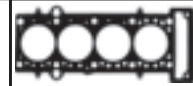
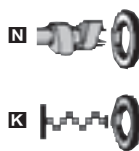
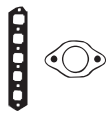

AC5920































AD5130, AD5140,
AD5150, AD5160,
AD5170



















JM5119



JH5051

		JM5288 W17B14A			NA5260 38x50x6mm		
HBS359 [®] (22-15018B) M11x1.50x150mm (x10)	JD5830  (50-030266-00) HA5031   (24-35043-00/0) HA5030   (24-35042-90/0) JD5829  (31-030265-00)	JM7034 (50-030264-00)			NA5258 27x47x7mm NA5259  40x55x6.4mm		
	JD5826  (50-030260-00) (Rubber) JD5827  (31-030261-00) (Rubber/Metal)	JM5119 (50-029489-00)	JH5051 (31-029592-00)	HR5061  (24-31944-50/0)	NA5139  32x45x6mm, FPM (50-319449-00) NA5140  91x111x10mm, FPM (50-319450-00)		
	JD5827  (31-030261-00) (Rubber/Metal)	JM5119 (50-029489-00)	JH5051 (31-029592-00)	HR5061  (24-31944-50/0)	NA5139  32x45x6mm, FPM (50-319449-00) NA5140  91x111x10mm, FPM (50-319450-00)		
	JD5826  (50-030260-00) (Rubber) JD5827  (31-030261-00) (Rubber/Metal)	JM5119 (50-029489-00)	JH5051 (31-029592-00)	HR5061  (24-31944-50/0)	NA5139  32x45x6mm, FPM (50-319449-00) NA5140  91x111x10mm, FPM (50-319450-00)		
	JD5827  (31-030261-00) (Rubber/Metal)	JM5119 (50-029489-00)	JH5051 (31-029592-00)	HR5061  (24-31944-50/0)	NA5139  32x45x6mm, FPM (50-319449-00) NA5140  91x111x10mm, FPM (50-319450-00)		
	JD5827  (31-030261-00) (Rubber/Metal)	JM5119 (50-029489-00)	JH5051 (31-029592-00)	HR5061  (24-31944-50/0)	NA5139  32x45x6mm, FPM (50-319449-00) NA5140  91x111x10mm, FPM (50-319450-00)		

		CC			9			CC			9
3A91	Petrol	1124	3	75.00	15	4 G 62 BT	Petrol	1795	4	80.60	214
4 D 55	Diesel	2347	4	91.10	105	4 G 62 BT	Petrol	1795	4	80.60	37
4 D 55 T	Diesel	2346	4	91.10	106	4 G 62 BT	Petrol	1795	4	80.60	46
4 D 55 T	Diesel	2346	4	91.10	167	4 G 63	Petrol	1997	4	85.00	102
4 D 56	Diesel	2476	4	91.10	110	4 G 63	Petrol	1997	4	85.00	104
4 D 56	Diesel	2476	4	91.10	112	4 G 63	Petrol	1997	4	85.00	142
4 D 56	Diesel	2476	4	91.10	158	4 G 63	Petrol	1997	4	85.00	146
4 D 56	Diesel	2476	4	91.10	169	4 G 63	Petrol	1997	4	85.00	160
4 D 56	Diesel	2476	4	91.10	188	4 G 63	Petrol	1997	4	85.00	197
4 D 56	Diesel	2476	4	91.10	34	4 G 63	Petrol	1997	4	85.00	198
4 D 56	Diesel	2476	4	91.10	47	4 G 63	Petrol	1997	4	85.00	202
4 D 56	Diesel	2476	4	91.10	92	4 G 63	Petrol	1997	4	85.00	215
4 D 56 T	Diesel	2476	4	91.10	111	4 G 63	Petrol	1997	4	85.00	217
4 D 56 T	Diesel	2476	4	91.10	113	4 G 63	Petrol	1997	4	85.00	219
4 D 56 T	Diesel	2476	4	91.10	117	4 G 63	Petrol	1997	4	85.00	220
4 D 56 T	Diesel	2476	4	91.10	170	4 G 63	Petrol	1997	4	85.00	225
4 D 56 T	Diesel	2476	4	91.10	189	4 G 63	Petrol	1997	4	85.00	55
4 D 56 T	Diesel	2476	4	91.10	200	4 G 63	Petrol	1997	4	85.00	57
4 D 56 T	Diesel	2476	4	91.10	48	4 G 63	Petrol	1997	4	85.00	63
4 D 56 T	Diesel	2476	4	91.10	93	4 G 63	Petrol	1997	4	85.00	70
4 D 56 T	Diesel	2476	4	91.10	94	4 G 63	Petrol	1997	4	85.00	71
4 D 56 TD	Diesel	2477	4	91.10	170	4 G 63	Petrol	1997	4	85.00	74
4 D 56 TD	Diesel	2477	4	91.10	200	4 G 63	Petrol	1997	4	85.00	75
4 D 65	Diesel	1796	4	80.60	139	4 G 63	Petrol	1997	4	85.00	77
4 D 65	Diesel	1796	4	80.60	157	4 G 63	Petrol	1997	4	85.00	91
4 D 65	Diesel	1796	4	80.60	31	4 G 63	Petrol	1997	4	85.00	99
4 D 65 T	Diesel	1796	4	80.60	192	4 G 63 T	Petrol	1997	4	85.00	216
4 D 65 T	Diesel	1796	4	80.60	213	4 G 63 T	Petrol	1997	4	85.00	54
4 D 65 T	Diesel	1796	4	80.60	67	4 G 63 T (ECI)	Petrol	1997	4	85.00	226
4 D 65 T	Diesel	1796	4	80.60	69	4 G 63 T/C	Petrol	1997	4	85.00	226
4 D 68	Diesel	1998	4	82.70	143	4 G 64	Petrol	2350	4	86.50	107
4 D 68	Diesel	1998	4	82.70	147	4 G 64	Petrol	2350	4	86.50	108
4 D 68 T	Diesel	1998	4	82.70	203	4 G 64	Petrol	2350	4	86.50	168
4 D 68 T	Diesel	1998	4	82.70	221	4 G 64	Petrol	2350	4	86.50	187
4 D 68 T	Diesel	1998	4	82.70	3	4 G 64	Petrol	2350	4	86.50	199
4 D 68 T	Diesel	1998	4	82.70	76	4 G 64	Petrol	2350	4	86.50	4
4 DR 5	Diesel	2659	4	92.00	49	4 G 67	Petrol	1836	4	81.50	32
4 DR 5	Diesel	2659	4	92.00	5	4 G 92	Petrol	1597	4	81.00	133
4 DR 5	Diesel	2659	4	92.00	90	4 G 92	Petrol	1597	4	81.00	134
4 G 12	Petrol	1410	4	74.00	23	4 G 92	Petrol	1597	4	81.00	27
4 G 13	Petrol	1298	4	71.00	120	4 G 92	Petrol	1597	4	81.00	8
4 G 13	Petrol	1298	4	71.00	18	4 G 93	Petrol	1834	4	81.00	10
4 G 13 (16 V)	Petrol	1299	4	71.00	118	4 G 93	Petrol	1834	4	81.00	137
4 G 13 (16 V)	Petrol	1299	4	71.00	205	4 G 93	Petrol	1834	4	81.00	140
4 G 13 (16 V)	Petrol	1299	4	71.00	206	4 G 93	Petrol	1834	4	81.00	141
4 G 13 (16 V)	Petrol	1299	4	71.00	21	4 G 93	Petrol	1834	4	81.00	163
4 G 13 (BJ90-92, 12V)	Petrol	1299	4	71.00	123	4 G 93	Petrol	1834	4	81.00	164
4 G 13 (BJ90-92, 12V)	Petrol	1299	4	71.00	124	4 G 93	Petrol	1834	4	81.00	201
4 G 13 (BJ90-92, 12V)	Petrol	1299	4	71.00	148	4 G 93	Petrol	1834	4	81.00	208
4 G 13 (BJ90-92, 12V)	Petrol	1299	4	71.00	151	4 G 93	Petrol	1834	4	81.00	210
4 G 13 (BJ90-92, 12V)	Petrol	1299	4	71.00	16	4 G 93	Petrol	1834	4	81.00	33
4 G 13 (BJ90-92, 12V)	Petrol	1299	4	71.00	22	4 G 93	Petrol	1834	4	81.00	66
4 G 13 (BJ90-92, 12V)	Petrol	1299	4	71.00	6	4 G 93	Petrol	1834	4	81.00	9
4 G 13 (BJ92, 12V)	Petrol	1299	4	71.00	121	4 M 40	Diesel	2835	4	95.00	174
4 G 13 (BJ92, 12V)	Petrol	1299	4	71.00	19	4A90	Petrol	1332	4	75.00	20
4 G 15	Petrol	1468	4	75.50	127	4A91	Petrol	1499	4	75.00	145
4 G 15	Petrol	1468	4	75.50	154	4A91	Petrol	1499	4	75.00	24
4 G 15 (16V)	Petrol	1468	4	75.50	129	4D68 SOHC	Diesel	1998	4	82.70	76
4 G 32 T/C	Petrol	1597	4	76.90	30	4G15	Petrol	1468	4	75.50	128
4 G 37	Petrol	1755	4	80.60	138	4G15	Petrol	1468	4	75.50	25
4 G 37	Petrol	1755	4	80.60	212	4G18	Petrol	1584	4	76.00	131
4 G 37	Petrol	1755	4	80.60	230	4G18	Petrol	1584	4	76.00	132
4 G 37	Petrol	1755	4	80.60	38	4G18	Petrol	1584	4	76.00	207
4 G 37	Petrol	1755	4	80.60	62	4G32	Petrol	1597	4	76.90	115
4 G 37	Petrol	1755	4	80.60	65	4G32	Petrol	1597	4	76.90	228
4 G 41	Petrol	1378	4	76.50	44	4G32	Petrol	1597	4	76.90	36
4 G 61	Petrol	1596	4	82.30	135	4G32	Petrol	1597	4	76.90	45
4 G 61	Petrol	1596	4	82.30	155	4G32	Petrol	1597	4	76.90	64
4 G 61	Petrol	1596	4	82.30	29	4G32	Petrol	1597	4	76.90	97

		CC			9			CC			9
4G32	Petrol	1597	4	76.90	98	G32BT	Petrol	1597	4	76.90	229
4G32 T	Petrol	1597	4	76.90	228	G32BT	Petrol	1597	4	76.90	28
4G32 T	Petrol	1597	4	76.90	36	G32BT	Petrol	1597	4	76.90	35
4G33	Petrol	1439	4	73.00	96	G33B	Petrol	1439	4	73.00	43
4G62 T	Petrol	1795	4	80.60	39	G37B	Petrol	1755	4	80.60	14
4G64 (GDI)	Petrol	2351	4	86.50	204	G37B	Petrol	1755	4	80.60	185
4G64 (GDI)	Petrol	2351	4	86.50	222	G37B	Petrol	1755	4	80.60	211
4G64 (GDI)	Petrol	2351	4	86.50	223	G37B	Petrol	1755	4	80.60	230
4G64 (GDI)	Petrol	2351	4	86.50	79	G37B	Petrol	1755	4	80.60	53
4G64 (GDI)	Petrol	2351	4	86.50	80	G37B	Petrol	1755	4	80.60	68
4G69	Petrol	2378	4	87.00	162	G54B	Petrol	2555	4	91.10	172
4G69	Petrol	2378	4	87.00	58	G54B	Petrol	2555	4	91.10	190
4G69	Petrol	2378	4	87.00	81	G54B	Petrol	2555	4	91.10	227
4G69	Petrol	2378	4	87.00	89	G54B	Petrol	2555	4	91.10	95
4G94	Petrol	1999	4	81.50	144	G54BT	Diesel	2555	4	91.10	171
4G94	Petrol	1999	4	81.50	166	G62B	Petrol	1796	4	80.60	231
4G94	Petrol	1999	4	81.50	73	G63B	Petrol	1997	4	85.00	101
4M40-A	Diesel	2835	4	95.00	173	G63B	Petrol	1997	4	85.00	186
4M41	Diesel	3200	4	98.50	182	G63B	Petrol	1997	4	85.00	193
4M41	Diesel	3200	4	98.50	183	G63B	Petrol	1997	4	85.00	218
6 G 72	Petrol	2972	6	91.10	114	G63B	Petrol	1997	4	85.00	232
6 G 72	Petrol	2972	6	91.10	149	G63B	Petrol	1997	4	85.00	40
6 G 72	Petrol	2972	6	91.10	175	G63B	Petrol	1997	4	85.00	71
6 G 72	Petrol	2972	6	91.10	176	G63B	Petrol	1997	4	85.00	72
6 G 72	Petrol	2972	6	91.10	177	G63B	Petrol	1997	4	85.00	91
6 G 72	Petrol	2972	6	91.10	178	G63BT	Petrol	1997	4	84.00	165
6 G 72	Petrol	2972	6	91.10	179	G64B	Petrol	2350	4	86.50	109
6 G 72	Petrol	2972	6	91.10	180	G64B	Petrol	2350	4	86.50	82
6 G 72	Petrol	2972	6	91.10	181	G6AT	Petrol	2972	6	91.10	87
6 G 72	Petrol	2972	6	91.10	191						
6 G 72	Petrol	2972	6	91.10	194						
6 G 72	Petrol	2972	6	91.10	195						
6 G 72	Petrol	2972	6	91.10	196						
6 G 72	Petrol	2972	6	91.10	2						
6 G 72	Petrol	2972	6	91.10	233						
6 G 72	Petrol	2972	6	91.10	41						
6 G 72	Petrol	2972	6	91.10	42						
6 G 72	Petrol	2972	6	91.10	50						
6 G 72	Petrol	2972	6	91.10	51						
6 G 72	Petrol	2972	6	91.10	52						
6 G 72	Petrol	2972	6	91.10	60						
6 G 72	Petrol	2972	6	91.10	85						
6 G 73	Petrol	2497	6	83.50	84						
6A12	Petrol	1999	6	78.40	78						
6A13	Petrol	2498	6	81.00	83						
6G72T	Petrol	2972	6	91.10	1						
6G74 DOHC	Petrol	3497	6	93.00	184						
6GCU	Petrol	3497	6	93.00	184						
BSY	Diesel	1968	4	81.00	159						
BSY	Diesel	1968	4	81.00	88						
D48H	Diesel	2476	4	91.10	86						
F8QT	Diesel	1870	4	80.00	12						
F9Q1	Diesel	1870	4	80.00	11						
F9Q1	Diesel	1870	4	80.00	209						
F9Q2	Diesel	1870	4	80.00	11						
F9Q2	Diesel	1870	4	80.00	209						
G13B	Petrol	1299	4	71.00	119						
G13B	Petrol	1299	4	71.00	122						
G13B	Petrol	1299	4	71.00	125						
G13B	Petrol	1299	4	71.00	152						
G13B	Petrol	1299	4	71.00	17						
G15B	Petrol	1468	4	75.50	126						
G15B	Petrol	1468	4	75.50	130						
G15B	Petrol	1468	4	75.50	153						
G15B	Petrol	1468	4	75.50	26						
G32B	Petrol	1597	4	76.90	13						
G32B	Petrol	1597	4	76.90	61						
G32BT	Petrol	1597	4	76.90	136						
G32BT	Petrol	1597	4	76.90	156						



KW/PS



Model						Year	Code	Material	Part No.	Image
3000 GT 3.0L GT						01/92 →	1	BV010 (Graphite) (x2)		
6G72T	2972	6	91.10	SOHC, Turbo, V6	206-238/280-324					
3000 GT Coupe 3.0L i 24V 4x4						06/92 → 08/99	2	BV010 (Graphite) (x2)	DV010	
6G72	2972	6	91.10	Injection, DOHC, V6	210/286					
Aspire 2.0L TD Diesel						11/97 → 10/01	3	AG5302 (Graphite), 1.40mm, 1 Hole		
4D68T	1998	4	82.70	Indirect Injection	66/90					
Canter 2.4L						08/01 →	4		CG8080	
4G64	2350	4	86.50	MPi, SOHC	91-97/124-132					
Canter 2.7L Diesel						01/71 → 08/91	5	BE410 (Graphite)	DM750	
Canter 2.7L D Diesel						01/71 → 08/91		→06/81 BM750 (Graphite)		→06/81
4DR5	2659	4	92.00		07/81 →					
Carisma 1.3L						09/00 → 10/04	6			
4G13 (BJ90-92, 12V)	1299	4	71.00		55/75					
Carisma 1.6L						12/98 → 06/06	7	BT890 (Graphite)	DT890	
	1597	4			70/95		(30-028919-00)			
	1597	4			76/103					
Carisma 1.6L						07/95 → 06/06	8	BT890 (Graphite)	DT890	
4G92	1597	4	81.00	Injection, SOHC	66/89		(30-028919-00)			
4G92	1597	4	81.00	Injection, SOHC	73/99					
Carisma 1.8L						07/95 → 06/06	9	BT890 (Graphite)	DT890	
Carisma 1.8L 16V GDI						09/97 → 06/06		(30-028919-00)		
Carisma 1.8L GDI						10/00 → 06/06				
4G93	1834	4	81.00	Injection, DOHC	85-110/116-150					
Carisma 1.8L 16V						07/95 → 06/06	10	AG7710 (MLS)	CG7700	
4G93	1834	4	81.00	Injection, DOHC	85-110/116-150		4G93K			
Carisma 1.9L DI-D Diesel						09/00 → 06/06	11	AC5070 (Fibre), 1.35mm, 2 Notches (30-029474-00) →0.653mm AC5080 (Fibre), 1.45mm, 1 Notch (30-029475-00) →0.653 → 0.786mm AC5090 (Fibre), 1.55mm, 3 Notches (30-029476-00) →0.786mm →	CC5060▲ (21-29483-20/0)	 (22-29474-00/0)
F9Q1	1870	4	80.00	Direct Injection, SOHC	75/102					
F9Q2	1870	4	80.00	Direct Injection, SOHC	85/116					
Carisma 1.9L TD Diesel						10/96 → 09/00	12	AD5030 (Fibre), 1.4mm, 2 Holes (30-029749-00) AD5040 (Fibre), 1.50mm, 1 Hole (30-029750-00) AD5050 (Fibre), 1.60mm, 3 Holes (30-029751-00)	DL961▲ (21-26632-21/0)	 (22-29474-00/0)
F8QT	1870	4	80.00	SOHC	66/89					
Celeste 1.6L						01/78 → 08/81	13	BD040 (Graphite)	DD042	
G32B	1597	4	76.90	SOHC	48-60/65-82					
Chariot 1.8L						01/84 →	14	BM830 (Fibre)	DM830	
G37B	1755	4	80.60	SOHC	61-62/83-84		(30-026721-10)	(21-26721-21/0)		

							 AC5070, AC5080, AC5090
							 AD5030, AD5040, AD5050
		JN889		PA968 (x24)			 BD040
							 BE410
							 BM750
				PA468 (x8)	☑ NJ042 48x70x12mm, NBR		 BM830
							 BT890
HBS215 [Ⓢ] (22-76001B) M10x1.25x95mm (x10)	JD5781 ■ JD5758 ■ ☑				☑ NK143 ■ 85x103x8mm, FPM		 BV010
HBS215 [Ⓢ] (22-76001B) M10x1.25x95mm (x10)	JD5781 ■ JD5758 ■ ☑ JD007 ■	JN800			☑ NJ242 35x50x8mm, NBR ☑ NK143 ■ 85x103x8mm, FPM		 JC124
HBS215 [Ⓢ] (22-76001B) M10x1.25x95mm (x10)	JD5781 ■ JD5758 ■ ☑				☑ NK143 ■ 85x103x8mm, FPM		 JC272
							 JD007
HBS215 [Ⓢ] (22-76001B) M10x1.25x95mm (x10)		JM5006 ■ 4G93K			☑ NK143 ■ 85x103x8mm, FPM		 JD409
HBS120 [Ⓢ] (22-51008B) M12x1.50x118mm (x10)	JD5189	JM5086	JH5041 ● KG5012 16x23x1.5mm	HR646 ■ 24-30670-60/0	☑ NF846 25x42x7mm, FPM/ACM (50-319516-00) ☑ NA5036 ■ 42x54x6mm, FPM (50-319473-00) ☑ NF850 ■ 85x105x8mm, FPM (50-319183-00)	HL5017 [245] ■	 JN365
HBS120 [Ⓢ] (22-51008B) M12x1.50x118mm (x10)	JD409 (31-026628-10)	JN732 (50-026632-00)	JH5041 ● KG5012 16x23x1.5mm	HR569 ■ 24-30667-00/0	☑ NF846 25x42x7mm, FPM/ACM (50-319516-00) ☑ NA5036 ■ 42x54x6mm, FPM (50-319473-00) ☑ NF850 ■ 85x105x8mm, FPM (50-319183-00)	HL5017 [245] ■	 JN732
	JC124 ■	JN365 (50-026766-00)	JJ075	KJ211 (x8) KJ577 (x4) [202]	☑ NJ242 35x50x8mm, NBR ☑ NJ005 ■ 44x60x7mm, NBR ☑ NJ006 ■ 72x96x9mm, FPM/ACM	NJ255 [70]	 JN889
	JC272 ■	JN365 (50-026766-00)	JJ075	KJ577 (x4) [202] KJ211 ■ (x8)	☑ NJ242 35x50x8mm, NBR ☑ NJ005 ■ 44x60x7mm, NBR ☑ NJ006 ■ 72x96x9mm, FPM/ACM	NJ255 [70]	 JJ075

MITSUBISHI



KW/PS



Colt 1.1L Mk VI 10/04 → 15								
3A91	1124	3	75.00	DOHC	55/75			
Colt 1.3L 12V 04/88 → 05/92 16						BT430 (Graphite) (30-028224-00) →12/96	DT430 (21-28224-20/0)	GT430 (20-28224-00/0)
4 G 13 (BJ90-92, 12V)	1299	4	71.00		55/75			
Colt 1.3L EL, GL 06/86 → 04/88 17						BN330 (Graphite) (30-028175-00)	DN332 DN330 (21-28175-20/0) 10/83 → 01/85	GN331 GN330 10/83 → 01/85
G13B	1299	4	71.00	SOHC	49-57/ 67-78			
Colt 1.3L GL 04/88 → 12/90 18						BN330 (Graphite) (30-028175-00)	DN332	FG7690
4 G 13	1298	4	71.00	SOHC	44/60			
Colt 1.3L GLi 12V 04/92 → 04/96 19						BT430 (Graphite) (30-028224-00)	DT430 (21-28224-20/0)	GT430 (20-28224-00/0)
4 G 13 (BJ92, 12V)	1299	4	71.00		55/75			
Colt 1.3L Mk VI 06/04 → 20						AG9920 (MLS)		
4A90	1332	4	75.00	DOHC	70/95			
Colt 1300 09/00 → 07/05 21						AG7690 (MLS) 01/01 → 4G13	CG7690 01/01 → 4G13	FF5470
4 G 13 (16 V)	1299	4	71.00	Injection, SOHC	63/86			
Colt 1300 GL, GLX 05/96 → 09/00 22						BT430 (Graphite) (30-028224-00)	DT430 (21-28224-20/0)	FF5470
4 G 13 (BJ90-92, 12V)	1299	4	71.00		55/75			
Colt 1.4L 05/79 → 12/86 23						BE070 (Graphite)	DE070 [205]	GE071 Great Britain GE072 [205]
4 G 12	1410	4	74.00	SOHC	51/70			
Colt 1.5L Mk VI 06/04 → 24						AG9920 (MLS)		
Colt Cabriolet 1.5L 05/06 →								
4A91	1499	4	75.00	DOHC	80/109			
Colt 1.5L 07/90 → 05/92 25						BT430 (Graphite) (30-028224-00)	DT430 (21-28224-20/0)	GT430 (20-28224-00/0)
Colt 1.5L GLXi 04/88 → 05/92								
4G15	1468	4	75.50	SOHC	61-66/ 83-90			
Colt 1.5L GLX 09/85 → 04/88 26						BN230 (Graphite) (30-026719-10)	DN230 →12/86 DN231 →12/86 DN233 (21-26719-23/0) 01/87 →	GN230 →12/86 GN231 →12/86 GN233 01/87 →
G15B	1468	4	75.50		51-57/ 70-78			
Colt 1.6L 02/94 → 04/96 27						BT890 (Graphite) (30-028919-00)	DT890	GT890
Colt 1.6L GLXi 16V 04/92 → 04/96								
Colt 1600 09/00 → 07/05								
Colt 1600 GLX 05/96 → 09/00								
4 G 92	1597	4	81.00	Injection, SOHC	66/89			
4 G 92	1597	4	81.00	SOHC	83/113			
Colt 1.6L 01/84 → 12/88 28						BK410 (Graphite)		
G32BT	1597	4	76.90	SOHC, Turbo	77/105			
Colt 1.6L GTi 16V 04/88 → 05/90 29						BS240 (Graphite) (30-028197-00)	DS240 →12/88 DS241 (21-28197-21/0) 01/89 →	GS240 →12/88 GS241 (20-28197-01/0) 01/89 →
4 G 61	1596	4	82.30	Injection, DOHC	91-100/ 124- 136			
Colt 1.6L Turbo Eci 02/84 → 04/88 30						BK410 (Graphite)	DK412	
4 G 32 T/C	1597	4	76.90	SOHC	92/125			

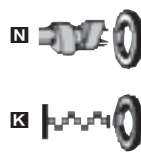
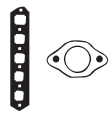

BE070



JJ075



BK410



JJ098



BN230



BN330



BS240



BT430



BT890



HA414



JC023



JC122



JC123



JC719



JC793



JC794



JC795



JD007



JN317



JN365

	JD5871 31-030347-00 (MLS)						
HBS440 (22-76022B) M10x1.25x100.0mm (x10)	JD5757	JM5022 (ACM)					
	HA414 JC719 JE199	JN317 (50-026219-00)	JJ098	KJ570 (x8) KJ577 (x4) [202]	NJ242 35x50x8mm, NBR NJ252 30x46x7mm, NBR NJ006 72x96x9mm, FPM/ACM		
		JN317 (50-026219-00)					
	JD5757						
	JD5905 (MLS)						
HBS477 (22-75009B)		HM5244 (NBR) 01/01→ 4G13					
HBS477 (22-75009B)	JD5757	JM5022 (ACM)					
	JC122 JC123 HA414 JC023	JN317 (50-026219-00)	JJ098	KJ570 (x8) KJ577 (x4) [202]	NJ242 35x50x8mm, NBR NJ252 30x46x7mm, NBR NJ006 72x96x9mm, FPM/ACM		
	JD5905 (MLS)						
	JD5757						
	JC122 JC123 JC793 01/87→ HA414 JC023 JC719 01/87→	JN317 (50-026219-00)	JJ098	KJ570 (x8) KJ577 (x4) [202]	NJ242 35x50x8mm, NBR NJ252 30x46x7mm, NBR NJ006 72x96x9mm, FPM/ACM		
HBS215 (22-76001B) M10x1.25x95mm (x10)	JD5781 JD5758 JD007	JN800			NJ242 35x50x8mm, NBR NK143 85x103x8mm, FPM		
		JN365 (50-026766-00)	JJ075	KJ577 (x4) [202] KJ211 (x8)	NJ242 35x50x8mm, NBR NJ005 44x60x7mm, NBR NJ006 72x96x9mm, FPM/ACM	NJ255 [70]	
	JC795 JC794 JF095 01/89→			PA968 (x16)	NJ242 (x2) 35x50x8mm, NBR NJ005 44x60x7mm, NBR NJ251 80x96x9mm, MVQ		



KW/PS



Colt 1.8L GL Diesel 02/84 → 04/88 31						BN220 (Graphite) (30-026722-10)	DN220	GN220 (20-26722-01/0)
Colt 1.8L GLX Diesel 04/88 → 05/92								
4 D 65	1796	4	80.60	Indirect Injection, SOHC	43-44/ 58-60			
Colt 1.8L GTi 16V 06/90 → 05/92 32						BS240 (Graphite) (30-028197-00)	DS240	
4 G 67	1836	4	81.50	Injection, DOHC	100/136			
Colt 1.8L GTi 16V 04/92 → 04/96 33						BT890 (Graphite) (30-028919-00)	DT890	
4 G 93	1834	4	81.00	Injection, DOHC	85-110/ 116- 150			
Colt 2.5L Diesel 01/87 → 12/88 34						BJ600 (Graphite) (30-026724-10)	DJ600 (21-26724-22/0)	GJ600 (20-26724-01/0)
4 D 56	2476	4	91.10	SOHC	51-54/ 69-73			
Cordia Coupe 1.6L 01/84 → 12/88 35						BK410 (Graphite)		
G32BT	1597	4	76.90	SOHC, Turbo	77/105			
Cordia Coupe 1.6L GSL 10/82 → 12/86 36						BK410 (Graphite)	DK412	
Cordia Coupe 1.6L Turbo 10/82 → 05/85								
4G32	1597	4	76.90	SOHC	48-55/ 65-75			
4G32 T	1597	4	76.90	SOHC	84-85/ 114- 116			
Cordia Coupe 1.8L → 04/84 37						BL450 (Graphite)	DL452	
4 G 62 BT	1795	4	80.60	SOHC, Turbo				
Cordia Coupe 1.8L GSL 10/86 → 12/86 38						BM830 (Fibre) (30-026721-10)	DM831	
4 G 37	1755	4	80.60	Carburettor, SOHC	63-71/ 86-97			
Cordia Coupe 1.8L Turbo ECi 10/84 → 12/86 39						BL450 (Graphite)	DL452	
4G62 T	1795	4	80.60	SPi	100/136			
Cordia Coupe 2.0L 01/84 → 12/88 40						BH060 (Graphite) (30-026723-10)	DH062	GH062 (20-26723-00/0)
G63B	1997	4	85.00	SOHC	62-75/ 84-102			
Debonair 3.0L 09/89 → 08/92 41								FG6120
6 G 72	2972	6	91.10	Injection, DOHC, V6	123- 151/ 167- 205			
Debonair 3.0L 12/90 → 42						BR600 (Graphite) (x2) (30-028200-00)	DR601	
6 G 72	2972	6	91.10	Injection, DOHC, V6	210/286			
Delica 1.4L 10/82 → 43						BK420 (Graphite) → 12/84	DK420 → 12/84	GK420 → 12/84
G33B	1439	4	73.00		50-68/ 68-92			
Delica 1.4L 01/71 → 12/79 44						AX190 (Fibre)		
Delica Van 1.4L 01/71 → 12/79								
4 G 41	1378	4	76.50	OHV				
Delica 1.6L 09/75 → 09/77 45						AJ690 (Graphite) → 09/75 BD010 (Graphite) 10/75 →	CJ690 ○ → 09/75 DD010 10/75 →	FJ690 [204] → 09/75 GD040
Delica Van 1.6L 09/75 → 09/77								
4G32	1597	4	76.90	SOHC	48-55/ 65-75			
Delica 1.8L Turbo → 04/84 46						BL450 (Graphite)	DL452	
4 G 62 BT	1795	4	80.60	SOHC, Turbo				

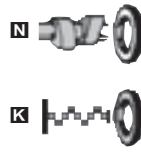
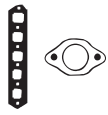

HBS307 ® (22-76004B) M12x1.25x104mm (x10)	JC554 ■	JN599 (50-026767-00)		KJ211 ■ (x8)	NJ242 35x50x8mm, NBR NJ005 ■ 44x60x7mm, NBR NJ251 ■ 80x96x9mm, MVQ	NJ255 [70]
HBS215 ® (22-76001B) M10x1.25x95mm (x10)	JD5781 ■ JD5758 ■ ■				NK143 ■ 85x103x8mm, FPM	
	JC224	JN403 (50-026769-00)	JJ072	KJ211 (x8)	NJ242 35x50x8mm, NBR NJ005 ■ 44x60x7mm, NBR NJ251 ■ 80x96x9mm, MVQ	NJ255 [70] NJ610 [15]
		JN365 (50-026766-00)	JJ075	KJ577 (x4) [202] KJ211 ■ (x8)	NJ242 35x50x8mm, NBR NJ005 ■ 44x60x7mm, NBR NJ006 ■ 72x96x9mm, FPM/ACM	NJ255 [70]
	JC493 ■ JC441 ■ JC611 ■	JN496 (50-026768-00)	JJ274	KJ577 (x4) [202] KJ211 ■ (x8)	NJ242 35x50x8mm, NBR NJ005 ■ 44x60x7mm, NBR NJ251 ■ 80x96x9mm, MVQ	NJ255 [70] NJ655 [70]
	JC968 ■ JC627 ■	JN365 (50-026766-00) HL502 ■ (24-26766-00/0)		KJ211 ■ (x8)	NJ242 35x50x8mm, NBR NJ005 ■ 44x60x7mm, NBR NJ006 ■ 72x96x9mm, FPM/ACM	
	JC493 ■ JC441 ■ JC611 ■	JN496 (50-026768-00)				
	JC612 ■ JC611 ■	JN496 (50-026768-00)	JJ274		NJ242 35x50x8mm, NBR NJ005 ■ 44x60x7mm, NBR NJ251 ■ 80x96x9mm, MVQ	NJ255 [70] NJ655 [70]
	JC969 ■ JC751 ■	JN713 (x2) (50-028201-00)		KJ211 (x12)	NJ242 ■ (x2) 35x50x8mm, NBR NJ874 ■ 37x50x6mm, ACM NJ873 ■ 91x111x9mm, FPM	
	JC124 ■ JC272 ■	JN365 (50-026766-00)	JJ075	KJ577 (x4) [202] KJ211 ■ (x8)	NJ242 35x50x8mm, NBR NJ005 ■ 44x60x7mm, NBR NJ006 ■ 72x96x9mm, FPM/ACM	NJ255 [70]
					NJ007 ■ 44x65x11mm, NBR	
	⊙ JE011	JM023 (50-028361-00)	JH034	KJ211 (x8)	NJ007 ■ 44x65x11mm, NBR NJ008 ■ 72x96x9mm, NBR	
	JC493 ■ JC441 ■ JC611 ■	JN496 (50-026768-00)	JJ274	KJ577 (x4) [202] KJ211 ■ (x8)	NJ242 35x50x8mm, NBR NJ005 ■ 44x60x7mm, NBR NJ251 ■ 80x96x9mm, MVQ	NJ255 [70] NJ655 [70]

06/83 →

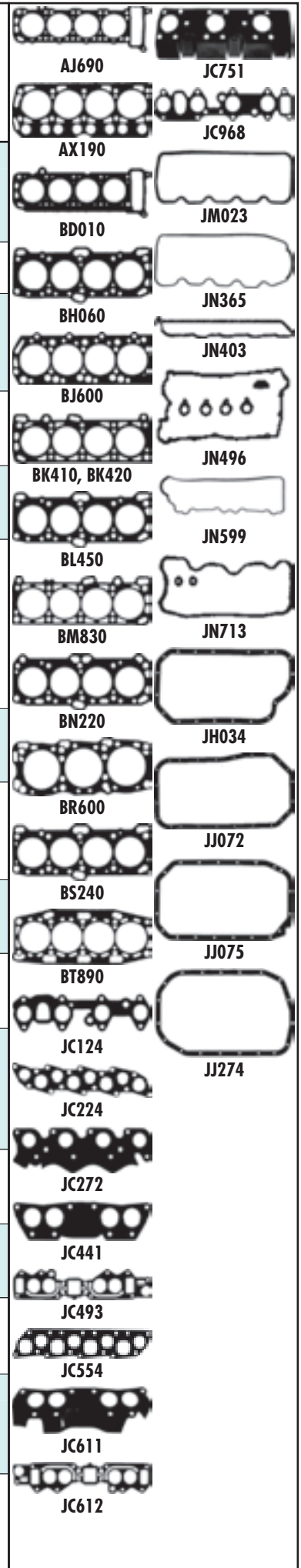

MITSUBISHI



KW/PS



Delica 2.5L D Diesel 01/87 → 12/88 47					BJ600 (Graphite) (30-026724-10)	DJ600 (21-26724-22/0)	GJ600 (20-26724-01/0)
4 D 56	2476	4	91.10	SOHC	51-54/ 69-73		
Delica 2.5L TD Diesel 03/86 → 48					BS130 (Graphite), 1,50mm (30-028225-00)	DS130 (21-28225-20/0)	GS130 (20-28225-00/0)
4 D 56 T	2476	4	91.10	SOHC, Turbo	63/85		
Delica Van 2.7L Diesel 01/71 → 08/91 49					BM750 (Graphite)	DM750 ■	GM750
4 D R 5	2659	4	92.00				
Diamante 3.0L 10/92 → 09/02 50					BV010 (Graphite)	DR601	FG6120
6 G 72	2972	6	91.10	Injection, DOHC, V6	123- 151/ 167- 205		
Diamante 3.0L 01/90 → 12/92 51					BR600 (Graphite) (x2) (30-028200-00)	DR601	
6 G 72	2972	6	91.10	Injection, DOHC, V6	210/286		
Diamante 3.0L 12/90 → 52					BV010 (Graphite) (x2)	DR601	
6 G 72	2972	6	91.10	Injection, DOHC, V6	210/286		
Eclipse 1.8L 01/84 → 53					BM830 (Fibre) (30-026721-10)	DM830 (21-26721-21/0)	GM830
G37B	1755	4	80.60	SOHC	61-62/ 83-84		
Eclipse 2.0L 01/90 → 12/90 54					BS120 (Graphite) (30-028203-00)	DS120 (21-28203-20/0)	EG6280 GS120 (20-28203-00/0)
4 G 63 T	1997	4	85.00	Injection, SOHC, Turbo	110/150		
Eclipse 2000 GS 16V 12/95 → 04/99 55							EG6280 FA5390
4 G 63	1997	4	85.00	SOHC	83-110/ 113- 150		
Eclipse 2000 GT 16V 12/95 → 04/99 56							EG6280
	1997	4			157/214		
Eclipse Coupe 2.0L i 16V 04/91 → 11/95 57					BS120 (Graphite) (30-028203-00)	DS120 (21-28203-20/0)	EG6280 GS120 (20-28203-00/0)
Eclipse Coupe 2.0L i 16V 4x4 04/91 → 11/95							
4 G 63	1997	4	85.00	SOHC	83-110/ 113- 150		
Eclipse 2.4L GS Mk IV 04/05 → 58					AG9130 (MLS), 0.4mm	CG9130	EG6270
4G69	2378	4	87.00	SOHC	121/165		
Eclipse 2400 GS 16V 09/98 → 04/99 59					AG9130 (MLS), 0.4mm	CG9130	
	2389	4			105/143		
Eclipse 3.0L Mk III 05/99 → 03/05 60							FG6120
6 G 72	2972	6	91.10	Injection, DOHC, V6	123- 151/ 167- 205		
Eterna 1.6L 01/78 → 08/81 61					BD040 (Graphite) → 08/81 BK410 (Graphite) 09/81 →	DD042 → 08/81 DK410 (21-26720-23/0) 09/81 → 12/82 DK412 01/83 →	GD042 → 08/81 GK410 09/81 → 12/83
G32B	1597	4	76.90	SOHC	48-60/ 65-82		
Eterna 1.8L 10/86 → 12/86 62					BM830 (Fibre) (30-026721-10)	DM831	
4 G 37	1755	4	80.60	Carburettor, SOHC	63-71/ 86-97		
Eterna 2.0L 16V 01/91 → 63					BS120 (Graphite) → 08/81 (30-028203-00)	DS120 (21-28203-20/0)	EG6280 GS120 (20-28203-00/0)
4 G 63	1997	4	85.00	SOHC	66-101/ 90-137		

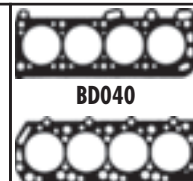
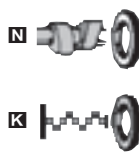
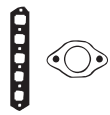

BD040

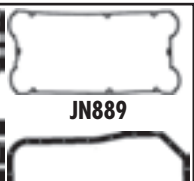

JN889

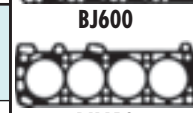

BJ600



JJ072

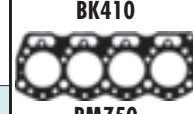

BK410



JJ075

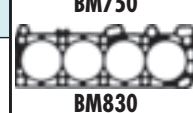

BM750



BM830

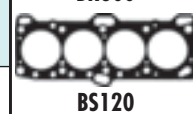

BR600

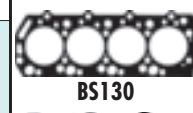

BS120



BS130



BV010



JC124



JC224



JC272



JC626



JC751



JC794

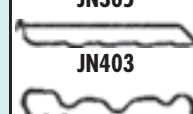

JC795

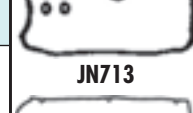

JC968



JN365



JN403



JN713











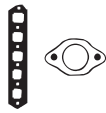

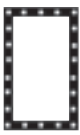

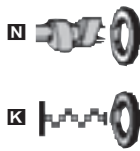

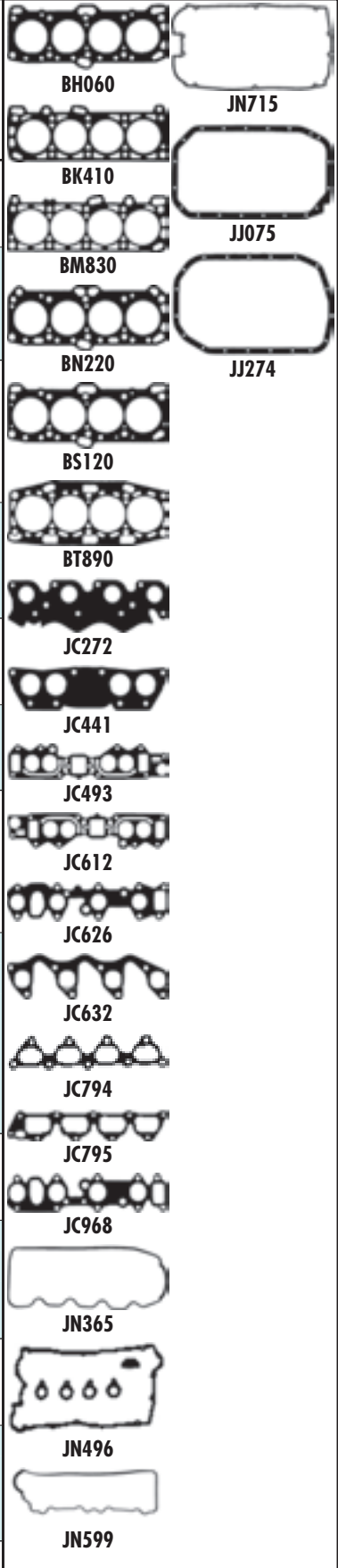













































































JN715



KW/PS



Galant 1.6L GLX		06/84 → 12/87		64		BK410 (Graphite)	DK412	GK410
4G32	1597	4	76.90	SOHC	48-55/ 65-75			
Galant 1.8L		11/87 → 10/92		65		BM830 (Fibre) (30-026721-10)	DM831	
4 G 37	1755	4	80.60	Carburettor, SOHC	63-71/ 86-97			
Galant 1.8L		02/94 → 08/96		66		BT890 (Graphite) (30-028919-00)	DT890	
Galant 1.8L GLSI		11/92 → 08/96						
4 G 93	1834	4	81.00	Injection, DOHC	85-110/ 116- 150			
Galant 1.8L Diesel		01/84 → 12/89		67		BN220 (Graphite) (30-026722-10)	DN221	GN221
Galant 1.8L non-UK Diesel		01/84 → 12/89						
4 D 65 T	1796	4	80.60	with balance shafts, Indirect Injection, SOHC, Turbo	55-60/ 75-82			
Galant 1.8L		01/84 →		68		BM830 (Fibre) (30-026721-10)	DM830 (21-26721-21/0)	GM830
G37B	1755	4	80.60	SOHC	61-62/ 83-84			
Galant 1.8L Turbo-D Diesel		06/84 → 10/92		69		BN220 (Graphite) (30-026722-10)	DN221	GN221
4 D 65 T	1796	4	80.60	Indirect Injection, SOHC	55-60/ 75-82			
Galant 2.0L Mk VI		09/96 → 09/00		70		BS120 (Graphite) (30-028203-00)	DS120 (21-28203-20/0)	GS120 (20-28203-00/0)
Galant 2.0L GTi 16V		11/88 → 10/92						
4 G 63	1997	4	85.00	SOHC	83-110/ 113- 150	AG5140 (Fibre), 1.3mm		
Galant 2.0L		11/87 → 10/92		71		BH060 (Graphite) (30-026723-10)	DH062 DH064	GH062 (20-26723-00/0) GH064
Galant 2.0L 4x4		12/88 → 10/92						
Galant 2.0L GLS		06/86 → 12/87						
G63B	1997	4	85.00	SOHC	62-75/ 84-102			
4 G 63	1997	4	85.00	SOHC	66-101/ 90-137			
Galant 2.0L		01/84 → 12/88		72		BH060 (Graphite) (30-026723-10)	DH062	GH062 (20-26723-00/0)
G63B	1997	4	85.00	SOHC	62-75/ 84-102			
Galant 2.0L GDi G		10/03 →		73				
Galant 2.0L GDI Mk VI		10/99 → 10/04						
Galant 2.0L GDi V 4x4		10/03 →						
4G94	1999	4	81.50	Injection, DOHC	95/129			
Galant 2.0L GLS		06/84 → 12/87		74		BH060 (Graphite) (30-026723-10)	DH064	GH064
4 G 63	1997	4	85.00	SOHC	66-101/ 90-137			
Galant 2.0L GLSI		11/92 → 08/96		75		BS120 (Graphite) (30-028203-00)	DS120 (21-28203-20/0)	EG6280 GS120 (20-28203-00/0)
Galant 2.0L GLSI 4x4		11/92 → 08/96						
4 G 63	1997	4	85.00	SOHC	66-101/ 90-137			
Galant 2.0L GLSTD Diesel		11/92 → 08/96		76		AG5302 (Graphite), 1.40mm, 1 Hole AG5300 (Graphite), 1.45mm, 2 Holes AG5301 (Graphite), 1.5mm, 3 Notches 4D68T	CG5520▲	
Galant 2.0L TDI Diesel		09/96 → 10/04						
4D68 SOHC	1998	4	82.70	Direct Injection, SOHC	66/89			
4 D 68 T	1998	4	82.70	Indirect Injection	66/90			

								
		JC626  JC272 	JN365 (50-026766-00)	JJ075	KJ577 (x4) [202] KJ211  (x8)	 NJ242 35x50x8mm, NBR  NJ005  44x60x7mm, NBR  NJ006  72x96x9mm, FPM/ACM	NJ255 [70]	BH060 BK410 BM830 BN220 BS120 BT890 JC272 JC441 JC493 JC612 JC626 JC632 JC794 JC795 JC968 JN365 JN496 JN715 JN788 JN999
		JC968  JC627 	JN365 (50-026766-00) HL502  (24-26766-00/0)		KJ211  (x8)	 NJ242 35x50x8mm, NBR  NJ005  44x60x7mm, NBR  NJ006  72x96x9mm, FPM/ACM		JN715 JJ075 JJ274
HBS215  (22-76001B) M10x1.25x95mm (x10)	JD5781  JD5758  					 NK143  85x103x8mm, FPM		
	JC632 	JN599 (50-026767-00)			KJ211  (x8)	 NJ242 35x50x8mm, NBR  NJ251  80x96x9mm, MVQ	NJ255 [70] NJ655 [70]	
	JC272 	JN365 (50-026766-00)	JJ075	KJ577 (x4) [202] KJ211  (x8)	 NJ242 35x50x8mm, NBR  NJ005  44x60x7mm, NBR  NJ006  72x96x9mm, FPM/ACM		NJ255 [70]	
HBS307  (22-76004B) M12x1.25x104mm (x10)	JC632 	JN599 (50-026767-00)			KJ211  (x8)	 NJ242 35x50x8mm, NBR  NJ251  80x96x9mm, MVQ	NJ255 [70] NJ655 [70]	
HBS307  (22-76004B) M12x1.25x104mm (x10)	JC795  JC794 	JN715 (50-028198-00)			PA968 (x16)	 NJ242 (x2) 35x50x8mm, NBR  NJ005  44x60x7mm, NBR  NJ251  80x96x9mm, MVQ	NJ655 [70]	
HBS307  (22-76004B) M12x1.25x104mm (x10)	JC493  JC612  JC441 	JN496 (50-026768-00) JN788	JJ274	KJ577 (x4) [202] KJ211  (x8)	 NJ242 35x50x8mm, NBR  NJ005  44x60x7mm, NBR  NJ251  80x96x9mm, MVQ		NJ655 [70]	
	JC493 	JN496 (50-026768-00)	JJ274			 NJ242 35x50x8mm, NBR  NJ005  44x60x7mm, NBR  NJ251  80x96x9mm, MVQ	NJ255 [70] NJ655 [70]	
		JM5290 JM5291						
HBS307  (22-76004B) M12x1.25x104mm (x10)	JC493  JC441   JE052	JN496 (50-026768-00) JN788	JJ274	KJ577 (x4) [202] KJ211  (x8)	 NJ242 35x50x8mm, NBR  NJ005  44x60x7mm, NBR  NJ251  80x96x9mm, MVQ		NJ655 [70]	
HBS354  (22-76006B) M11x1.25x97mm (x10)	JC795  JC794 	JN715 (50-028198-00)			PA968 (x16)	 NJ242 (x2) 35x50x8mm, NBR  NJ005  44x60x7mm, NBR  NK143  85x103x8mm, FPM  NJ251  80x96x9mm, MVQ	NJ655 [70]	
HBS421 (22-76024B) M11x1.25x118mm (x10)						 NK143  85x103x8mm, FPM		



KWPS



Galant 2.0L GTi 16V		11/87 → 10/92		77		BS120 (Graphite) (30-028203-00)	DS120 (21-28203-20/0)	GS120 (20-28203-00/0)
Galant 2.0L GTi 16V 4x4		06/88 → 12/92						
Galant 2.0L GTi 16V CAT 4x4		09/91 → 10/92						
4 G 63	1997	4	85.00	SOHC	83-110/ 113- 150			
Galant 2.0L V6 24V		11/92 → 08/96		78		AF5500 (Graphite) (x2) 6A12	CF5500	EG6230
6A12	1999	6	78.40	Carburettor, DOHC, V6	108- 110/ 147- 150			
Galant 2.4L GDI		02/99 → 09/00		79		AG9130 (MLS), 0.4mm	CG9130	
4G64 (GDI)	2351	4	86.50	Injection, DOHC	110/150			
Galant 2.4L GDI		02/99 → 10/04		80		AG9130 (MLS), 0.4mm	CG9130	
4G64 (GDI)	2351	4	86.50	Injection, DOHC	110/150			
Galant 2.4L GDI Mk VI		10/03 → 10/04		81		AG9130 (MLS), 0.4mm	CG9130	EG6270
Galant 2.4L GDi Sport		10/03 →						
Galant 2.4L GDi Sport 4x4		10/03 →						
4G69	2378	4	87.00	SOHC	121/165			
Galant 2.4L GLS		07/85 → 12/87		82		BT880 (Graphite)	DT880	GT880
664B	2350	4	86.50	SOHC	80-82/ 109- 112			
Galant 2.5L V6 24V		09/96 → 10/04		83		AG9150 (Fibre), Soft Material Gasket (x2)	CG9150	EG6230
6A13	2498	6	81.00	Injection, DOHC, V6	120/163			
Galant 2.5L V6 24V		11/92 → 08/96		84		AG9150 (Fibre), Soft Material Gasket (x2)	CG9150	EG6230
6 G 73	2497	6	83.50	DOHC, V6	125/170			
Galant 3.0L		12/90 →		85		BR600 (Graphite) (x2) (30-028200-00)	DR601	
6 G 72	2972	6	91.10	Injection, DOHC, V6	210/286			
Galoper 2.5L TD Diesel		02/99 →		86		BS130 (Graphite), 1.50mm (30-028225-00)	DS130 (21-28225-20/0)	GS130 (20-28225-00/0)
Galoper 2.5L TD intercooler Diesel		02/99 →						
D4BH	2476 2476	4 4	91.10	CIH	65/88 59-78/ 80-106			
Galoper 3.0L V6		02/99 →		87		BR600 (Graphite) (x2) (30-028200-00)		GR600
G6AT	2972	6	91.10	Injection, SOHC, V6	104- 107/ 140- 146			
Grandis 2.0L DI-D Diesel		09/05 →		88		AG8970 (MLS), 1.55mm, 1 Hole 30-030249-00 AG8800 (MLS), 1.63mm, 2 Holes (30-030213-00) AG8960 (MLS), 1.71mm, 3 Holes (30-030248-00)		
BSY	1968	4	81.00	Direct Injection, DOHC	100/136			
Grandis 2.4L		04/04 →		89				
4G69	2378	4	87.00	SOHC	121/165	AG9130 (MLS), 0.4mm	CG9130	EG6270
Jeep 2.7L Diesel		01/71 → 08/91		90		BE410 (Graphite) → 06/81 BM750 (Graphite) 07/81 →	DM750 ■	GE410 ○ [12] → 06/81 GM750
4 D R 5	2659	4	92.00					

HBS307 ® (22-76004B) M12x1.25x104mm (x10) HBS354 ® (22-76006B) M11x1.25x97mm (x10)	JC795 ■ JC794 ■	JN715 (50-028198-00)		PA968 (x16)	NJ242 (x2) 35x50x8mm, NBR NJ005 ■ 44x60x7mm, NBR NJ251 ■ 80x96x9mm, MVQ	NJ655 [70]	BE410 BM750 BR600 BS120 BS130 BT880 JC224 JC611 JC612 JC751 JC794 JC795 JN403 JN496 JN713 JN715 JJ072	
HBS217 ® (22-76003B) M10x1.25x95mm (x16)		HM5245 ■ 6A12						
HBS354 ® (22-76006B) M11x1.25x97mm (x10)								
		JM7041 (Rubber)						
HBS307 ® (22-76004B) M12x1.25x104mm (x10)	JC612 ■ JC611 ■	JN496 (50-026768-00)		KJ577 (x4) [202] KJ211 ■ (x8)	NJ242 35x50x8mm, NBR NJ005 ■ 44x60x7mm, NBR NJ251 ■ 80x96x9mm, MVQ	NJ255 [70] NJ655 [70] NJ610 [15]		
HBS217 ® (22-76003B) M10x1.25x95mm (x16)		JM7039 (Rubber)						
		JM7039 (Rubber)						
	JC969 ■ JC751 ■	JN713 (x2) (50-028201-00)		KJ211 (x12)	NJ242 ■ (x2) 35x50x8mm, NBR NJ874 ■ 37x50x6mm, ACM NJ873 ■ 91x111x9mm, FPM			
HBS295 ® (22-70013B) M12x1.25x104mm (x18)	JC224	JN403 (50-026769-00)	JJ072					
HBS364 ® (22-39032B) M12x1.75x149mm (x10)		JM7031 50-030223-00 (Rubber)				KK5522 [86]		
		JM7041 (Rubber)						
				PA468 (x8)	NJ042 48x70x12mm, NBR			







MITSUBISHI

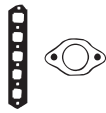

KW/PS

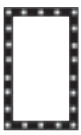

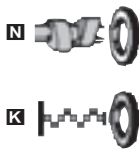
L200 2.0L					01/84 → 12/93	91	BH060 (Graphite) (30-026723-10)	DH064	GH064
G63B	1997	4	85.00	SOHC		62-75/ 84-102			
4 G 63	1997	4	85.00	SOHC		66-101/ 90-137			
L200 2.5L D Diesel					11/86 → 08/96	92	BJ600 (Graphite) (30-026724-10)	DJ600 (21-26724-22/0)	EJ603 GJ600 (20-26724-01/0)
L200 2.5L D 4WD Diesel					12/87 → 05/93				
4 D 56	2476	4	91.10	SOHC		51-54/ 69-73			
L200 2.5L TD Diesel					08/03 →	93	BS130 (Graphite), 1,50mm (30-028225-00)	DS130 (21-28225-20/0)	
L200 2.5L TD 4WD Diesel					09/01 →				
4 D 56 T	2476	4	91.10	SOHC		63/85 74/100 98/133			
2477	4								
2477	4								
L200 2.5L TD 4WD Diesel					11/92 → 08/96	94	BS130 (Graphite), 1,50mm (30-028225-00)	DS130 (21-28225-20/0)	GS130 (20-28225-00/0)
4 D 56 T	2476	4	91.10	SOHC		63/85			
L200 2.6L					11/89 → 05/95	95	BJ890 (Graphite) (30-028226-00)	DJ891	GJ891
L200 2.6L 4WD (K33T)					11/89 → 05/95				
G54B	2555	4	91.10			76-114/ 103- 155			
L300 1.4L					04/90 → 05/94	96	BD980 (Graphite)		
4G33	1439	4	73.00	SOHC		50/68			
L300 1.6L					09/81 → 04/94	97	BK410 (Graphite)	DK412	
L300 Van 1.6L					05/80 → 10/86				
4G32	1597	4	76.90	SOHC		48-55/ 65-75			
L300 Van 1.6L					02/80 → 10/02	98	BK410 (Graphite)		
4G32	1597	4	76.90	SOHC		48-55/ 65-75			
L300 2.0L					07/94 →	99	AA5390 (Graphite) 4G63 BH060 (Graphite) (30-026723-10)	CA5390 4G63	FA5390
4 G 63	1997	4	85.00	SOHC		83-110/ 113- 150			
L300 2.0L					06/94 → 04/00	100			FA5390
	1997	4				83/113			
L300 2.0L					11/86 →	101			
G63B	1997	4	85.00	SOHC		62-75/ 84-102			
L300 2.0L					11/86 →	102	BH060 (Graphite) (30-026723-10)	DH064	GH064
4 G 63	1997	4	85.00	SOHC		66-101/ 90-137			
L300 2.0L					07/96 →	103	AA5390 (Graphite) 4G63	CA5390 4G63	FA5390
	1997	4				83/113			
L300 2.0L 4WD					11/86 →	104	BH060 (Graphite) (30-026723-10)	DH064	GH064
L300 2.0L 4x4					11/86 → 02/87				
4 G 63	1997	4	85.00	SOHC		66-101/ 90-137			
L300 2.3L D Diesel					04/83 → 10/86	105	BJ600 (Graphite) (30-026724-10)	DJ601 (21-26724-21/0)	EJ603
L300 Van 2.3L D Diesel					09/83 → 10/86				
4 D 55	2347	4	91.10	Indirect Injection, SOHC		48-62/ 65-84			
L300 2.3L Turbo Diesel					01/73 → 12/82	106	BJ600 (Graphite) (30-026724-10)	DJ601 (21-26724-21/0)	GJ601
4 D 55 T	2346	4	91.10	SOHC, Turbo		49/67			

							
HBS307 ® (22-76004B) M12x1.25x104mm (x10)	JC493 ■	JN496 (50-026768-00)	JJ274	KJ577 (x4) [202] KJ211 ■ (x8)	<input checked="" type="checkbox"/> NJ242 ■ (x2) 35x50x8mm, NBR <input checked="" type="checkbox"/> NJ005 ■ 44x60x7mm, NBR <input checked="" type="checkbox"/> NJ251 ■ 80x96x9mm, MVQ	NJ655 [70]	
HBS295 ® (22-70013B) M12x1.25x104mm (x18)	JC224	JN403 (50-026769-00)	JJ072	KJ211 (x8)	<input checked="" type="checkbox"/> NJ242 35x50x8mm, NBR <input checked="" type="checkbox"/> NJ005 ■ 44x60x7mm, NBR <input checked="" type="checkbox"/> NJ251 ■ 80x96x9mm, MVQ	NJ255 [70] NJ610 [15]	
HBS295 ® (22-70013B) M12x1.25x104mm (x18)	JC224	JN403 (50-026769-00)					
HBS295 ® (22-70013B) M12x1.25x104mm (x18)	JC224	JN403 (50-026769-00)	JJ072	KJ211 (x8)	<input checked="" type="checkbox"/> NJ242 35x50x8mm, NBR <input checked="" type="checkbox"/> NJ005 ■ 44x60x7mm, NBR <input checked="" type="checkbox"/> NJ251 ■ 80x96x9mm, MVQ	NJ255 [70] NJ610 [15]	
		JN427 (50-028227-00)	JJ072	KJ211 (x8)	<input checked="" type="checkbox"/> NJ334 23x34x8mm, ACM <input checked="" type="checkbox"/> NJ251 ■ 80x96x9mm, MVQ		
HBS354 ® (22-76006B) M11x1.25x97mm (x10)		HM5239 ■			<input checked="" type="checkbox"/> NK143 ■ 85x103x8mm, FPM		
HBS307 ® (22-76004B) M12x1.25x104mm (x10)							
HBS307 ® (22-76004B) M12x1.25x104mm (x10)	JC493 ■ ⊙ JE052	JN496 (50-026768-00) JN788	JJ274	KJ577 (x4) [202] KJ211 ■ (x8)	<input checked="" type="checkbox"/> NJ242 35x50x8mm, NBR <input checked="" type="checkbox"/> NJ005 ■ 44x60x7mm, NBR <input checked="" type="checkbox"/> NJ251 ■ 80x96x9mm, MVQ	NJ655 [70]	
		HM5239 ■			<input checked="" type="checkbox"/> NK143 ■ 85x103x8mm, FPM		
HBS307 ® (22-76004B) M12x1.25x104mm (x10)	JC493 ■ ⊙ JE052 (x4)	JN496 (50-026768-00) JN788	JJ274	KJ211 ■ (x8)	<input checked="" type="checkbox"/> NJ242 35x50x8mm, NBR <input checked="" type="checkbox"/> NJ005 ■ 44x60x7mm, NBR <input checked="" type="checkbox"/> NJ251 ■ 80x96x9mm, MVQ	NJ655 [70]	
HBS295 ® (22-70013B) M12x1.25x104mm (x18)							
	JC224	JN403 (50-026769-00)	JJ072	KJ211 (x8)	<input checked="" type="checkbox"/> NJ242 35x50x8mm, NBR <input checked="" type="checkbox"/> NJ005 ■ 44x60x7mm, NBR <input checked="" type="checkbox"/> NJ251 ■ 80x96x9mm, MVQ	NJ255 [70] NJ610 [15]	

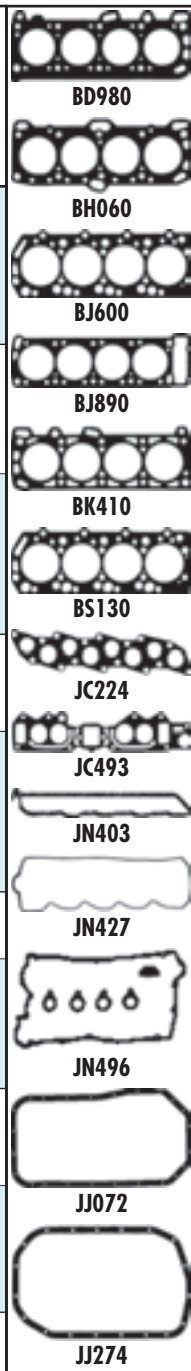

MITSUBISHI



KW/PS



L300 2.4L		09/97 → 05/03		107		AG8080 (Graphite)	CG8080	
4 G 64	2350	4	86.50	MPI, SOHC	91-97/ 124- 132			
L300 2.4L		11/90 →		108				
L300 2.4L 4WD		11/90 →						
4 G 64	2350	4	86.50	SOHC	82/111			
L300 2.4L 4WD		11/86 → 12/90		109		BT880 (Graphite)	DT880	GT880
G64B	2350	4	86.50	SOHC	80-82/ 109- 112			
L300 2.5L D Diesel		11/86 → 04/94		110		BJ600 (Graphite)	DJ600	EJ603
L300 Van 2.5L D Diesel		11/86 →				(30-026724-10)	(21-26724-22/0)	GJ600 (20-26724-01/0)
4 D 56	2476	4	91.10	SOHC	51-54/ 69-73			
L300 2.5L D Diesel		11/94 →		111		BS130 (Graphite), 1,50mm	DS130	EJ603
4 D 56 T	2476	4	91.10	SOHC	63/85	(30-028225-00)	(21-28225-20/0)	
L300 2.5L D Diesel		01/87 → 12/88		112		BJ600 (Graphite)	DJ600	GJ600
4 D 56	2476	4	91.10	SOHC	51-54/ 69-73	(30-026724-10)	(21-26724-22/0)	(20-26724-01/0)
L300 2.5L TD 4WD Diesel		11/88 →		113		BS130 (Graphite), 1,50mm	DS130	GS130
4 D 56 T	2476	4	91.10	SOHC	63/85	(30-028225-00)	(21-28225-20/0)	(20-28225-00/0)
L300 3.0L 4x4		10/00 → 05/03		114				FG6120
6 G 72	2972	6	91.10	Injection, DOHC, V6	123- 151/ 167- 205			
L400 Van 1.6L		02/80 → 10/02		115		BK410 (Graphite)		
4G32	1597	4	76.90	SOHC	48-55/ 65-75			
L400 2.0L		09/95 → 10/02		116				FA5390
	1997	4			83/113			
L400 2500 TD Diesel		06/96 →		117		BS130 (Graphite), 1,50mm	DS130	GS130
L400 Van 2500 TD Diesel		09/96 →				(30-028225-00)	(21-28225-20/0)	(20-28225-00/0)
4 D 56 T	2476	4	91.10	SOHC	63/85			
Lancer 1.3L		09/03 →		118		AG7690 (MLS)	CG7690	FG7690
4 G 13 (16 V)	1299	4	71.00	Injection, SOHC	63/86	4G13	4G13	
Lancer 1.3L		08/88 → 05/92		119		BN330 (Graphite)	DN332	
G13B	1299	4	71.00	SOHC	49-57/ 67-78	(30-028175-00)		
Lancer 1.3L		04/88 → 05/92		120		BN330 (Graphite)	DN332	FG7690
4 G 13	1298	4	71.00	SOHC	44/60	(30-028175-00)		
Lancer 1.3L		06/92 →		121		BT430 (Graphite)	DT430	GT430
4 G 13 (BJ92, 12V)	1299	4	71.00		55/75	(30-028224-00)	(21-28224-20/0)	(20-28224-00/0)
Lancer 1.3L		10/83 → 12/90		122		BN330 (Graphite)	DN330	GN330
G13B	1299	4	71.00	SOHC	49-57/ 67-78	(30-028175-00)	(21-28175-20/0) →12/85 DN332 01/86 →	→12/85 GN331 →12/85

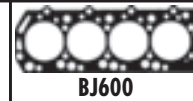
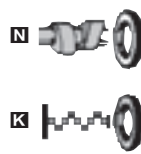
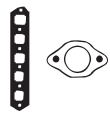

BJ600



JJ098



BK410



BN330



BS130



BT430



BT880



HA414



JC023



JC122



JC123



JC224



JC611



JC612



JC719

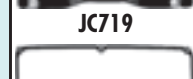

JN317



JN403



JN496



JN897



JJ072

HBS307 ® (22-76004B) M12x1.25x104mm (x10)						
HBS307 ® (22-76004B) M12x1.25x104mm (x10)						
HBS307 ® (22-76004B) M12x1.25x104mm (x10)	JC612 ■ JC611 ■	JN496 (50-026768-00)		KJ211 (x8)	<input checked="" type="checkbox"/> NJ242 35x50x8mm, NBR <input checked="" type="checkbox"/> NJ005 ■ 44x60x7mm, NBR <input checked="" type="checkbox"/> NJ251 ■ 80x96x9mm, MVQ	NJ255 [70] NJ655 [70]
HBS295 ® (22-70013B) M12x1.25x104mm (x18)	JC224	JN403 (50-026769-00)	JJ072	KJ211 (x8)	<input checked="" type="checkbox"/> NJ242 35x50x8mm, NBR <input checked="" type="checkbox"/> NJ005 ■ 44x60x7mm, NBR <input checked="" type="checkbox"/> NJ251 ■ 80x96x9mm, MVQ	NJ255 [70]
HBS295 ® (22-70013B) M12x1.25x104mm (x18)	JC224	JN403 (50-026769-00)	JJ072	KJ211 (x8)	<input checked="" type="checkbox"/> NJ242 35x50x8mm, NBR <input checked="" type="checkbox"/> NJ005 ■ 44x60x7mm, NBR <input checked="" type="checkbox"/> NJ251 ■ 80x96x9mm, MVQ	NJ255 [70] NJ610 [15]
HBS295 ® (22-70013B) M12x1.25x104mm (x18)	JC224	JN403 (50-026769-00)	JJ072	KJ211 (x8)	<input checked="" type="checkbox"/> NJ242 35x50x8mm, NBR <input checked="" type="checkbox"/> NJ005 ■ 44x60x7mm, NBR <input checked="" type="checkbox"/> NJ251 ■ 80x96x9mm, MVQ	NJ255 [70]
HBS295 ® (22-70013B) M12x1.25x104mm (x18)	JC224	JN403 (50-026769-00)	JJ072	KJ211 (x8)	<input checked="" type="checkbox"/> NJ242 35x50x8mm, NBR <input checked="" type="checkbox"/> NJ005 ■ 44x60x7mm, NBR <input checked="" type="checkbox"/> NJ251 ■ 80x96x9mm, MVQ	NJ255 [70]
		HM5244 ■ (NBR) 4G13				
	JC719 ■ ⊙ JE199	JN317 (50-026219-00)	JJ098	KJ570 (x8) KJ577 [202]	<input checked="" type="checkbox"/> NJ242 35x50x8mm, NBR <input checked="" type="checkbox"/> NJ252 ■ 30x46x7mm, NBR <input checked="" type="checkbox"/> NJ006 ■ 72x96x9mm, FPM/ACM	
	JC719 ■ ⊙ JE199	JN317 (50-026219-00)	JJ098	KJ570 (x8) KJ577 [202]	<input checked="" type="checkbox"/> NJ242 35x50x8mm, NBR <input checked="" type="checkbox"/> NJ252 ■ 30x46x7mm, NBR <input checked="" type="checkbox"/> NJ006 ■ 72x96x9mm, FPM/ACM	
HBS440 (22-76022B) M10x1.25x100.0mm (x10)	JD5757 ■	JN897				
	JC122 ■ →12/85 JC123 ■ →12/85 HA414 ■ JC023 ■ →12/85 JC719 ■ 01/86→ ⊙ JE199 01/86→	JN317 (50-026219-00)	JJ098	KJ570 (x8) KJ577 (x4) [202]	<input checked="" type="checkbox"/> NJ242 35x50x8mm, NBR <input checked="" type="checkbox"/> NJ252 ■ 30x46x7mm, NBR <input checked="" type="checkbox"/> NJ006 ■ 72x96x9mm, FPM/ACM	











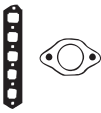

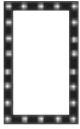

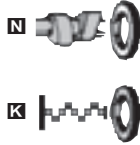



















MITSUBISHI



KW/PS



Lancer 1.3L 12V		01/91 → 05/94		123		BT430 (Graphite) (30-028224-00)	DT430 (21-28224-20/0)	FF5470 GT430 (20-28224-00/0)
Lancer 1.3L GL		07/90 → 07/93						
4 G 13 (BJ90-92, 12V)	1299	4	71.00		55/75			
Lancer 1.3L 12V GL, GLX		12/95 → 08/03		124		AF5470 (MLS)	CF5470	FF5470
Lancer 1.3L 16V Mk V		09/97 → 10/99						
Lancer 1.3L GL Mk III		07/90 → 08/92						
Lancer 1.3L GL Mk IV		07/90 → 05/92						
Lancer 1.3L Mk V		06/92 → 08/03						
4 G 13 (BJ90-92, 12V)	1299	4	71.00		55/75			
Lancer 1.3L GL Mk III		05/88 → 06/90		125		BN330 (Graphite) (30-028175-00)	DN332	
Lancer 1.3L GL Mk IV		05/88 → 06/90						
Lancer 1.3L Mk IV		05/88 → 06/90						
G13B	1299	4	71.00	SOHC	49-57/ 67-78			
Lancer 1.5L		09/85 → 08/89		126		BN230 (Graphite) (30-026719-10) →12/88	DN230 →12/86 DN231 →12/86 DN233 (21-26719-23/0) 01/87 → 12/88	GN230 →12/86 GN231 →12/86 GN233 01/87 → 12/88
G15B	1468	4	75.50		51-57/ 70-78			
Lancer 1.5L		09/85 → 12/87		127		BN230 (Graphite) (30-026719-10)	DN231	
Lancer 1.5L GLX		11/83 → 04/88						
4 G 15	1468	4	75.50		55/75			
Lancer 1.5L		04/88 → 05/92		128		BT430 (Graphite) (30-028224-00)	DT431 →12/90 DT430 (21-28224-20/0) 01/91 →	GT431 →12/90 GT430 (20-28224-00/0) 01/91 →
Lancer 1.5L 12V		05/89 → 05/92						
4G15	1468	4	75.50	SOHC	61-66/ 83-90 66/90			
4G15	1468	4	75.50					
Lancer 1.5L 16V		12/95 → 08/03		129				
4 G 15 (16V)	1468	4	75.50	Injection, DOHC	69/93			
Lancer 1.5L GLX		06/85 → 04/88		130		BN230 (Graphite) (30-026719-10)	DN230 →12/86 DN231 →12/86 DN233 (21-26719-23/0) 01/87 →	GN230 →12/86 GN231 →12/86 GN233 01/87 →
G15B	1468	4	75.50		51-57/ 70-78			
Lancer 1.6L		09/03 →		131		AF5480 (MLS)	CF5481	
4G18	1584	4	76.00	DOHC	72/98			
Lancer 1.6L		09/03 →		132		AF5480 (MLS)	CF5481	
4G18	1584	4	76.00	DOHC	72/98			
Lancer 1.6L		02/94 →		133		BT890 (Graphite) (30-028919-00)	DT890	
4 G 92	1597	4	81.00	Injection, SOHC	66/89			

								
HBS440 (22-76022B) M10x1.25x100.0mm (x10)	JD5757 ■	JN897						 BN230
	JD5757 ■	JM5022 (ACM)						 BN330
	 	JN317 (50-026219-00)	JJ098	KJ570 (x8) KJ577 (x4) [202]	 NJ242 35x50x8mm, NBR  NJ252 30x46x7mm, NBR  NJ006 72x96x9mm, FPM/ACM			 BT430
	JC122 ■ →12/88 JC123 ■ →12/88 JC793 ■ 01/87→12/88 HA414 ■ ■ ■ →12/88 JC023 ■ JC719 ■ 01/87→12/88	JN317 (50-026219-00) →12/88	JJ098 →12/88	KJ570 (x8) KJ577 (x4) [202]	 NJ242 35x50x8mm, NBR  NJ252 30x46x7mm, NBR  NJ006 72x96x9mm, FPM/ACM			 BT890
								 HA414
								 JC023
								 JC122
								 JC123
								 JC719
								 JC793
	JD5757 ■ JD023 ■	JN897 →12/90		PA968 (x12)	 NJ242 35x50x8mm, NBR  NJ252 30x46x7mm, NBR  NJ006 72x96x9mm, FPM/ACM			 JD023
		JM5022 (ACM)						 JE719
	JC122 ■ JC123 ■ JC793 ■ 01/87→ HA414 ■ ■ ■ JC023 ■ JC719 ■ 01/87→	JN317 (50-026219-00)	JJ098	KJ570 (x8) KJ577 (x4) [202]	 NJ242 35x50x8mm, NBR  NJ252 30x46x7mm, NBR  NJ006 72x96x9mm, FPM/ACM			 JN317
								 JN897
								 JJ098
HBS477 (22-75009B)								
HBS215 ⊕ (22-76001B) M10x1.25x95mm (x10)	JD5781 ■ JD5758 ■ ■ ■							



KW/PS



Lancer 1.6L 16V		06/92 → 08/03		134		BT890 (Graphite) (30-028919-00)		DT890		GT890	
Lancer 1.6L 16V 4WD		06/92 →									
Lancer 1.6L GLi 16V		06/92 → 05/94									
Lancer 1.6L GLXi 16V		12/92 → 10/03									
Lancer 1.6L GLXi 16V 4WD		12/92 → 10/03									
4 G 92	1597	4	81.00	Injection, SOHC	66/89						
4 G 92	1597	4	81.00	SOHC	83/113						
Lancer 1.6L 16V		04/88 → 05/90		135		BS240 (Graphite) (30-028197-00)		DS240 → 12/88 DS241 (21-28197-21/0) 01/89 →		GS240 GS241 (20-28197-01/0) 01/89 →	
4 G 61	1596	4	82.30	Injection, DOHC	91-100/ 124- 136						
Lancer 1.6L Turbo		01/84 → 12/88		136		BK410 (Graphite)					
G32BT	1597	4	76.90	SOHC, Turbo	77/105						
Lancer 1.8L 16V		06/92 → 12/93		137		BT890 (Graphite) (30-028919-00)		DT890			
4 G 93	1834	4	81.00	Injection, DOHC	85-110/ 116- 150						
Lancer 1.8L 4x4		01/87 → 12/87		138		BM830 (Fibre) (30-026721-10) 01/87 → 12/87		DM831			
4 G 37	1755	4	80.60	Carburettor, SOHC	63-71/ 86-97						
Lancer 1.8L D Diesel		01/84 → 06/92		139		BN220 (Graphite) (30-026722-10)		DN220		GN220 (20-26722-01/0)	
Lancer 1.8L GLX D Diesel		04/88 → 05/92									
4 D 65	1796	4	80.60	Indirect Injection, SOHC	43-44/ 58-60						
Lancer 1.8L GDi T		09/03 →		140		BT890 (Graphite) (30-028919-00)		DT890			
Lancer 1.8L Mk VI		09/95 → 08/03									
Lancer 1.8L SEi Limited		09/03 →									
4 G 93	1834	4	81.00	Injection, DOHC	85-110/ 116- 150						
Lancer 1.8L GTi 16V		06/92 → 12/93		141		BT890 (Graphite) (30-028919-00)		DT890			
4 G 93	1834	4	81.00	Injection, DOHC	85-110/ 116- 150						
Lancer 2.0L		09/03 →		142		AG5140 (Fibre), 1.3mm				FA5390	
4 G 63	1997	4	85.00	SOHC	83-110/ 113- 150						
Lancer 2.0L D Diesel		06/92 →		143		AG5302 (Graphite), 1.40mm, 1 Hole		CG5520▲			
Lancer 2.0L D Mk VI Diesel		09/95 → 08/03				AG5300 (Graphite), 1.45mm, 2 Holes					
Lancer 2.0L GLX D Diesel		12/92 → 10/03				AG5301 (Graphite), 1.5mm, 3 Notches					
4 D 68	1998	4	82.70	SOHC	50/68	4D68					
Lancer 2.0L GDi		09/03 →		144							
Lancer 2.0L Mk VI		09/95 → 08/03									
4G94	1999	4	81.50	Injection, DOHC	95/129						
Lancer 1.5L		06/08 →		145		AG9920 (MLS)					
Lancer 1.5L Sportback		06/08 →									
4A91	1499	4	75.00	DOHC	80/109						

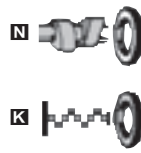
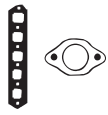

BK410



BM830



BN220



BS240



BT890



JC554



JC794



JC795



JC968



JD007



JN365



JN599



JJ075

HBS215[Ⓢ]
(22-76001B)
M10x1.25x95mm (x10)

JD5758 ■
JD5781 ■
JD007 ■

JN800

■ NJ242 35x50x8mm, NBR
■ NK143 ■ 85x103x8mm, FPM

JC795 ■
JC794 ■
Ⓢ JF095
01/89 →

PA968 (x16)

■ NJ242 ■ (x2) 35x50x8mm, NBR
■ NJ005 ■ 44x60x7mm, NBR
■ NJ251 ■ 80x96x9mm, MVQ

JN365
(50-026766-00)
HL502 ■
(24-26766-00/0)

JJ075

KJ577 (x4) [202]
KJ211 ■ (x8)

■ NJ242 35x50x8mm, NBR
■ NJ005 ■ 44x60x7mm, NBR
■ NJ006 ■ 72x96x9mm, FPM/ACM

NJ255 [70]

HBS215[Ⓢ]
(22-76001B)
M10x1.25x95mm (x10)

JD5758 ■
JD5781 ■

■ NK143 ■ 85x103x8mm, FPM

JC968 ■
JC627 ■

JN365
(50-026766-00)
HL502 ■
(24-26766-00/0)

KJ211 ■ (x8)

■ NJ242 35x50x8mm, NBR
■ NJ005 ■ 44x60x7mm, NBR
■ NJ006 ■ 72x96x9mm, FPM/ACM

HBS307[Ⓢ]
(22-76004B)
M12x1.25x104mm (x10)

JC554 ■

JN599
(50-026767-00)

KJ211 ■ (x8)

■ NJ242 35x50x8mm, NBR
■ NJ005 ■ 44x60x7mm, NBR
■ NJ251 ■ 80x96x9mm, MVQ

NJ255 [70]

NJ610 [15]

HBS215[Ⓢ]
(22-76001B)
M10x1.25x95mm (x10)

JD5781 ■
JD5758 ■ ■ ■

■ NK143 ■ 85x103x8mm, FPM

HBS421
(22-76024B)
M11x1.25x118mm (x10)

■ NK143 ■ 85x103x8mm, FPM

JM5290
JM5291

JD5905 ■
(MLS)



KW/PS



Model		Year Range		Power (KW/PS)		Parts	
Lancer 2.0L		12/03 →		146		AG5140 (Fibre), 1.3mm	
4 G 63	1997	4	85.00	SOHC	83-110/ 113- 150		FA5390
Lancer 2.0L D Mk IV Diesel		06/92 → 07/93		147		AG5302 (Graphite), 1.40mm, 1 Hole AG5300 (Graphite), 1.45mm, 2 Holes AG5301 (Graphite), 1.5mm, 3 Notches 4D68	
4 D 68	1998	4	82.70	SOHC	50/68	CG5520▲	
Libero 1.3L		09/99 → 08/03		148			
4 G 13 (BJ90-92, 12V)	1299	4	71.00		55/75		FF5470
Magna 3.0L		04/96 → 08/02		149			
6 G 72	2972	6	91.10	Injection, DOHC, V6	123- 151/ 167- 205		FG6120
Minica 0.7L		08/93 → 03/98		150		AG7680 (Graphite)	
Minica 0.7L 4x4		08/93 → 03/98					
	659	4			41/56 47/64		FG7680
Mirage 1.3L		09/95 → 07/03		151			
Mirage Coupe 1.3L		09/95 → 08/99					
4 G 13 (BJ90-92, 12V)	1299	4	71.00		55/75		FF5470
Mirage 1.3L		10/83 → 12/90		152		BN330 (Graphite) (30-028175-00)	
G13B	1299	4	71.00	SOHC	49-57/ 67-78	DN330 (21-28175-20/0) →12/85 DN332 01/86 →	GN330 →12/85 GN331 →12/85
Mirage 1.5L		10/83 → 12/88		153		BN230 (Graphite) (30-026719-10)	
G15B	1468	4	75.50		51-57/ 70-78	DN230 →12/86 DN231 →12/86 DN233 (21-26719-23/0) 01/87 →	GN230 →12/86 GN231 →12/86 GN233 01/87 →
Mirage 1.5L		01/89 →		154		BT430 (Graphite) (30-028224-00)	
4 G 15	1468	4	75.50		55/75	DT431 →12/89 DT430 (21-28224-20/0) 01/90 →	GT430 (20-28224-00/0) →12/90 GT431 →12/90
Mirage 1.6L 16V		04/88 → 05/90		155		BS240 (Graphite) (30-028197-00)	
4 G 61	1596	4	82.30	Injection, DOHC	91-100/ 124- 136	DS240 →12/88 DS241 (21-28197-21/0) 01/89 →	GS240 GS241 (20-28197-01/0) 01/89 →
Mirage 1.6L Turbo		01/84 → 12/88		156		BK410 (Graphite)	
G32BT	1597	4	76.90	SOHC, Turbo	77/105		
Mirage 1.8L D Diesel		01/84 → 12/88		157		BN220 (Graphite) (30-026722-10)	
4 D 65	1796	4	80.60	with balance shafts, Indirect Injection, SOHC	43-44/ 58-60	DN220	GN220 (20-26722-01/0)

							BK410 BN220 BN230 BN330 BS240 BT430 HA414 JC023 JC122 JC123 JC554 JC719 JC793 JC794 JC795 JD023 JN317 JN365 JN599 JN897 JJ075 JJ098	JN897 JJ075 JJ098
HBS421 (22-76024B) M11x1.25x118mm (x10)					NK143 85x103x8mm, FPM			
		JM5289						
	JC122 →12/85 JC123 →12/85 HA414 JC023 →12/85 JC719 01/86→ JE199 01/86→	JN317 (50-026219-00)	JJ098	KJ570 (x8) KJ577 (x4) [202]	NJ242 35x50x8mm, NBR NJ252 30x46x7mm, NBR NJ006 72x96x9mm, FPM/ACM			
	JC122 JC123 JC793 01/82→12/88 HA414 JC023 JC719 01/87→12/88	JN317 (50-026219-00) →12/88	JJ098 →12/88	KJ570 (x8) KJ577 (x4) [202]	NJ242 35x50x8mm, NBR NJ252 30x46x7mm, NBR NJ006 72x96x9mm, FPM/ACM			
	JD023	JN897 →12/90		PA968 (x12)	NJ242 35x50x8mm, NBR NJ252 30x46x7mm, NBR NJ006 72x96x9mm, FPM/ACM			
	JC795 JC794 JF095 01/89→			PA968 (x16)	NJ242 (x2) 35x50x8mm, NBR NJ005 44x60x7mm, NBR NJ251 80x96x9mm, MVQ			
		JN365 (50-026766-00)	JJ075	KJ577 (x4) [202] KJ211 (x8)	NJ242 35x50x8mm, NBR NJ005 44x60x7mm, NBR NJ006 72x96x9mm, FPM/ACM	NJ255 [70]		
	JC554	JN599 (50-026767-00)		KJ211 (x8)	NJ242 35x50x8mm, NBR NJ005 44x60x7mm, NBR NJ251 80x96x9mm, MVQ	NJ255 [70]		

MITSUBISHI



KW/PS



Model		Fuel		Year Range		Power (kW/PS)		Accessories		
Montero 2.5LD Diesel				01/87 → 12/88		158		BJ600 (Graphite) (30-026724-10)	DJ600 (21-26724-22/0)	GJ600 (20-26724-01/0)
4 D 56	2476	4	91.10	SOHC		51-54/ 69-73				
Outlander 2.0L DI-D Diesel				02/07 →		159				
BSY	1968	4	81.00	Direct Injection, DOHC		100/136				
Outlander 2.0L				05/03 →		160				FA5390
Outlander 2.0L 4WD				05/03 →						
4 G 63	1997	4	85.00	SOHC		83-110/ 113- 150				
Outlander 2.0L Turbo 4WD				04/04 →		161		AG8970 (MLS), 1.55mm, 1 Hole 30-030249-00 AG8800 (MLS), 1.63mm, 2 Holes (30-030213-00) AG8960 (MLS), 1.71mm, 3 Holes (30-030248-00)		
	1997	4				148/201				
Outlander 2.4L 4WD				11/03 →		162		AG9130 (MLS), 0.4mm	CG9130	EG6270
4G69	2378	4	87.00	SOHC		121/165				
Pajero 1.8L				11/01 →		163		AG7700 (MLS)	CG7700	
Pajero 1.8L GDI				10/99 →				4G93(GDI)	4G93(GDI)	
4 G 93	1834	4				88/120 85-110/ 116- 150				
	1834	4	81.00	Injection, DOHC						
Pajero 1.8L GDI				06/98 → 04/00		164		AG7700 (MLS)	CG7700	
4 G 93	1834	4	81.00	Injection, DOHC		85-110/ 116- 150		01/99 → 4G93(GDI)	01/99 → 4G93(GDI)	
Pajero 2.0L				05/85 →		165		BH060 (Graphite)		
G63BT	1997	4	84.00	SOHC, Turbo				(30-026723-10)		
Pajero 2.0L GDI				10/00 →		166		AG7700 (MLS)		
Pajero 2.0L GDi Allrad				10/01 → 02/05				4G94(GDI)		
4G94	1999	4	81.50	Injection, DOHC		95/129				
Pajero 2.3L TD Diesel				12/82 → 04/86		167		BJ600 (Graphite)	DJ601	GJ601
Pajero 2.3L Turbo Diesel				01/82 → 12/86				(30-026724-10)	(21-26724-21/0)	
Pajero 2.5 D Diesel				01/73 → 12/82						
4 D 55 T	2346	4	91.10	SOHC, Turbo		49/67				
4 D 55 T	2346	4	91.10	SOHC		49/67				
Pajero 2.4L				04/91 → 04/00		168				
4 G 64	2350	4	86.50	SOHC		82/111				
Pajero 2.5L D Diesel				01/87 → 12/88		169		BJ600 (Graphite)	DJ600	GJ600
4 D 56	2476	4	91.10	SOHC		51-54/ 69-73		(21-26724-22/0)	(20-26724-01/0)	
Pajero 2.5L TD Diesel				03/86 → 04/00		170		BS130 (Graphite), 1,50mm	DS130	GS130
4 D 56 T	2476	4	91.10	SOHC, Turbo		63/85		(30-028225-00)	(21-28225-20/0)	
4 D 56 T	2476	4	91.10	SOHC		63/85			(20-28225-00/0)	
	2477	4				85/115				
4 D 56 TD	2477	4	91.10	Indirect Injection, SOHC		73/99				
Pajero 2.5 D Diesel				01/82 → 12/88		171		BJ890 (Graphite)		
G54BT	2555	4	91.10	Turbo				(30-028226-00)		
Pajero 2.6L Montero				01/83 →		172		BJ890 (Graphite)	DJ898	GJ897
G54B	2555	4	91.10			76-114/ 103- 155		(30-028226-00)	(21-28226-20/0)	
Pajero 2.8L D Allrad Mk II Diesel				11/93 → 07/97		173				
4M40-A	2835	4	95.00	SOHC		69/93				

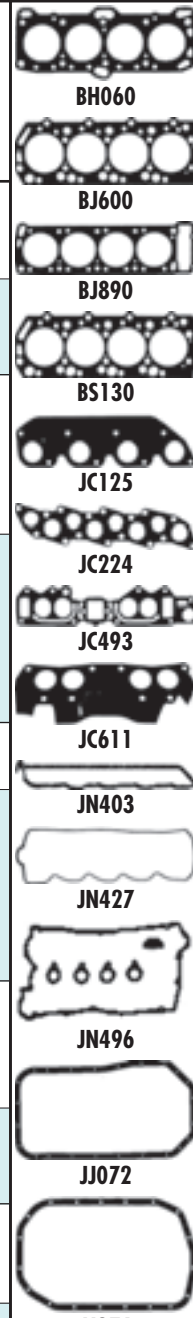
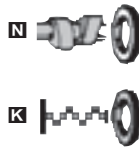
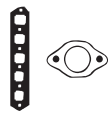

BH060

BJ600

BJ890

BS130

JC125

JC224

JC493

JC611

JN403

JN427

JN496

JJ072

JJ274

	JC224	JN403 <i>(50-026769-00)</i>	JJ072	KJ211 (x8)	<input checked="" type="checkbox"/> NJ242 35x50x8mm, NBR <input checked="" type="checkbox"/> NJ005 44x60x7mm, NBR <input checked="" type="checkbox"/> NJ251 80x96x9mm, MVQ	NJ255 [70] NJ610 [15]
		JM7031 50-030223-00 (Rubber)				KK5522 [86]
		JM7041 (Rubber)				
HBS215 [®] <i>(22-76001B)</i> M10x1.25x95mm (x10)		HM5271 [■] (ACM) 4G93(GDI)			<input checked="" type="checkbox"/> NK143 85x103x8mm, FPM	
HBS215 [®] <i>(22-76001B)</i> M10x1.25x95mm (x10)		HM5271 [■] (ACM) 01/99 → 4G93(GDI)			<input checked="" type="checkbox"/> NK143 85x103x8mm, FPM	
	JC493 [■] JC611 [■]	JN496 <i>(50-026768-00)</i>	JJ274	KJ577 (x4) [202] KJ211 [■] (x8)	<input checked="" type="checkbox"/> NJ242 35x50x8mm, NBR <input checked="" type="checkbox"/> NJ005 44x60x7mm, NBR <input checked="" type="checkbox"/> NJ251 80x96x9mm, MVQ	NJ655 [70] NJ610 [15]
HBS215 [®] <i>(22-76001B)</i> M10x1.25x95mm (x10)		JM5290 JM5291			<input checked="" type="checkbox"/> NK143 85x103x8mm, FPM	
HBS295 [®] <i>(22-70013B)</i> M12x1.25x104mm (x18)	JC224	JN403 <i>(50-026769-00)</i>	JJ072	KJ211 (x8)	<input checked="" type="checkbox"/> NJ242 35x50x8mm, NBR <input checked="" type="checkbox"/> NJ005 44x60x7mm, NBR <input checked="" type="checkbox"/> NJ251 80x96x9mm, MVQ	NJ255 [70] NJ610 [15]
HBS307 [®] <i>(22-76004B)</i> M12x1.25x104mm (x10)						
	JC224	JN403 <i>(50-026769-00)</i>	JJ072	KJ211 (x8)	<input checked="" type="checkbox"/> NJ242 35x50x8mm, NBR <input checked="" type="checkbox"/> NJ005 44x60x7mm, NBR <input checked="" type="checkbox"/> NJ251 80x96x9mm, MVQ	NJ255 [70] NJ610 [15]
HBS295 [®] <i>(22-70013B)</i> M12x1.25x104mm (x18)	JC224	JN403 <i>(50-026769-00)</i>	JJ072			
	JC125 [■]	JN427 <i>(50-028227-00)</i>	JJ072		<input checked="" type="checkbox"/> NJ334 23x34x8mm, ACM	
		JN427 <i>(50-028227-00)</i>	JJ072	KJ211 (x8)	<input checked="" type="checkbox"/> NJ334 23x34x8mm, ACM <input checked="" type="checkbox"/> NJ057 48x68x11mm, ACM <input checked="" type="checkbox"/> NJ251 80x96x9mm, MVQ	
	JA5014 [■]					

MITSUBISHI



KW/PS

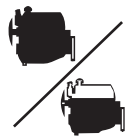

Pajero 2.8L TD Diesel		06/94 → 04/00		174	AG5160 (Fibre), 1.35mm, 2 Holes AA5020 (Fibre), 1.45mm, 4 Holes	CA5021▲	EA5020
4 M 40	2835	4	95.00	SOHC	92/125		
Pajero 3.0L		12/90 →		175	BR600 (Graphite) (x2) (30-028200-00)	DR601	GR600
6 G 72	2972	6	91.10	Injection, DOHC, V6	210/286		
Pajero 3.0L (V73W) Mk III		10/01 →		176			FG6120
Pajero 3.0L V6		03/03 →					
Pajero 3.0L V6 24V		06/94 → 04/00					
6 G 72	2972	6	91.10	Injection, DOHC, V6	123- 151/ 167- 205		
Pajero 3.0L V6		11/98 →		177		DR600 (21-28200-20/0)	FG6120
6 G 72	2972	6	91.10	Injection, DOHC, V6	123- 151/ 167- 205		
Pajero 3.0L V6		06/00 →		178	AG6120 (MLS) (x2) 6672	CG6120 6672	FG6120 6672
6 G 72	2972	6	91.10	Injection, DOHC, V6	123- 151/ 167- 205		
Pajero 3.0L V6		11/88 → 12/95		179	BR600 (Graphite) (x2) (30-028200-00)	DR601	GR600
6 G 72	2972	6	91.10	Injection, V6	104- 108/ 141- 147		
6 G 72	2972	6	91.10	V6	110/150		
Pajero 3.0L V6 24V		06/97 → 04/00		180	BV010 (Graphite) (x2)	DR600 (21-28200-20/0)	GR600
6 G 72	2972	6	91.10	Injection, DOHC, V6	123- 151/ 167- 205		
Pajero 3.0L V6 24V		06/94 → 05/97		181	BV010 (Graphite) (x2)	DR600 (21-28200-20/0)	GR600
6 G 72	2972	6	91.10	Injection, DOHC, V6	123- 151/ 167- 205		
Pajero 3.2L DiD Diesel		09/99 →		182	AG7740 (MLS), 0.5mm, 1 Notch 01/01 → 4M41	CF5490 01/01 → 4M41	FF5490▲
Pajero 3.2L DI-D Diesel		04/00 → 10/01					
Pajero 3.2L DiD Allrad Diesel		09/99 → 09/06					
Pajero 3.2L DI-D Classic Diesel		05/05 →					
Pajero 3.2L DI-D Mk IV Diesel		02/07 →					
Pajero 3.2L TDi Diesel		11/98 →					
4M41	3200	4	98.50	Direct Injection, DOHC	118/160 AF5490 (MLS), 0.6mm, 3 Notches 01/01 → 4M41 AG7760 (MLS), 0.65mm, 4 Notches 01/01 → 4M41		

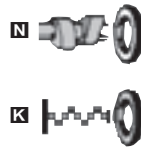
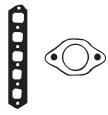

BR600



BV010



JC751

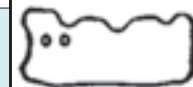

JN713



JN889

HBS216 (22-76002B) M12x1.25x124mm (x4) M8x1.25x90mm (x2) M12x1.25x104mm (x14)	JA5014	HM5230 JM5279			<input checked="" type="checkbox"/> NA5243 50x74x11mm <input checked="" type="checkbox"/> NA5244 91x114x12mm	
HBS402 (22-76018B)	JC969 JC751	JN713 (x2) (50-028201-00)		KJ211 (x12)	<input checked="" type="checkbox"/> NJ242 (x2) 35x50x8mm, NBR <input checked="" type="checkbox"/> NJ874 37x50x6mm, ACM <input checked="" type="checkbox"/> NJ873 91x111x9mm, FPM	
	JD5759	JM5247 (x2) →12/99 6672				
	JD5759	JM5247 (x2) 6672				
HBS402 (22-76018B) 01/90 →	JC969 JC751	JN713 (x2) (50-028201-00)		KJ211 (x12)	<input checked="" type="checkbox"/> NJ242 (x2) 35x50x8mm, NBR <input checked="" type="checkbox"/> NJ874 37x50x6mm, ACM <input checked="" type="checkbox"/> NJ873 91x111x9mm, FPM	
HBS402 (22-76018B) 01/90 →	JD5759	JN889 JM5247 (x2) →12/99 6672		PA968 (x24)		
HBS402 (22-76018B) 01/90 →	JD5759	JN889 JM5247 (x2) 01/95 → 6672		PA968 (x24)		
		JM5292 01/01 → 4M41			<input checked="" type="checkbox"/> NA5245 29x43x8mm <input checked="" type="checkbox"/> NA5243 50x74x11mm	



KW/PS



Pajero 3.2L DI-D Diesel				10/01 →	183	AG7740 (MLS), 0.5mm, 1 Notch 4M41 AG7750 (MLS), 0.55mm, 2 Notches 4M41 AF5490 (MLS), 0.6mm, 3 Notches 4M41 AG7760 (MLS), 0.65mm, 4 Notches 4M41		CF5490 01/01 → 4M41	FF5490 ▲
4M41	3200	4	98.50	Direct Injection, DOHC	118/160				
Pajero 3.5L V6 24V Pajero 3.5L V6 GDI				06/94 →04/00 04/00 →	184	AG5150 (Fibre), 1.4mm		CG5150	EG6220
66CU	3497	6	93.00		143-149/ 194-203				
6674 DOHC	3497	6	93.00	DOHC, V6	153/208				
Sapporo 1.8L				01/84 →	185	BM830 (Fibre) (30-026721-10)		DM830 (21-26721-21/0)	GM830
637B	1755	4	80.60	SOHC	61-62/ 83-84				
Sapporo 2.0L				01/84 →12/88	186	BH060 (Graphite) (30-026723-10)		DH061 (21-26723-23/0) →04/85	GH061 →04/85
663B	1997	4	85.00	SOHC	62-75/ 84-102				
Sapporo Coupe 2.4L				06/87 →08/90	187	AG8080 (Graphite)		CG8080	
4 G 64	2350	4	86.50	MPi, SOHC	91-97/ 124- 132				
Shogun 2.5L D Diesel				01/86 →12/91	188	BJ600 (Graphite) (30-026724-10)		DJ600 (21-26724-22/0)	GJ600 (20-26724-01/0)
4 D 56	2476	4	91.10	SOHC	51-54/ 69-73				
Shogun 2.5L TD Diesel				03/86 →	189	BS130 (Graphite), 1.50mm (30-028225-00)		DS130 (21-28225-20/0)	GS130 (20-28225-00/0)
4 D 56 T	2476	4	91.10	SOHC, Turbo	63/85				
Shogun 2.6L				01/83 →	190	BJ890 (Graphite) (30-028226-00)		DJ898 (21-28226-20/0) →01/87	GJ897 (20-28226-00/0) →01/87
654B	2555	4	91.10		76-114/ 103- 155				
Shogun 3.0L				12/90 →	191	BR600 (Graphite) (x2) (30-028200-00)		DR601 12/89 →01/94	
6 G 72	2972	6	91.10	Injection, DOHC, V6	210/286				
Sigma 1.8L Turbo Diesel				01/84 →12/89	192	BN220 (Graphite) (30-026722-10)		DN221	GN221
4 D 65 T	1796	4	80.60	with balance shafts, Indirect Injection, SOHC, Turbo	55-60/ 75-82				
Sigma 2.0L				01/84 →12/88	193	BH060 (Graphite) (30-026723-10)			
663B	1997	4	85.00	SOHC	62-75/ 84-102				
Sigma 3.0L				01/90 →12/92	194	BR600 (Graphite) (x2) (30-028200-00)		DR601 12/89 →12/91	
6 G 72	2972	6	91.10	Injection, DOHC, V6	210/286				
Sigma 3.0L V6				12/90 →07/96	195	BV010 (Graphite) (x2)			EG5220 FG6120
6 G 72	2972	6	91.10	V6	125- 133/ 170- 181				
Sigma 3.0L V6				12/90 →07/96	196	BV010 (Graphite) (x2)			EG6220 FG6120
6 G 72	2972	6	91.10	Injection, DOHC, V6	123- 151/ 167- 205				
Space Gear 2.0L 16V				08/96 →05/00	197	AA5390 (Graphite) 4G63		CA5390 4G63	FA5390
4 G 63	1997	4	85.00	SOHC	83-110/ 113- 150				

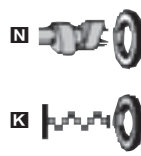
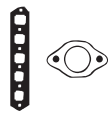

BH060



JN889



BJ600



JJ072



BJ890



JJ075



BM830



JJ274



BN220



BR600



BS130



BV010



JC224



JC272



JC612



JC632



JC751

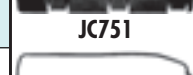

JN365



JN403

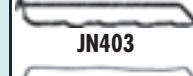

JN427



JN496

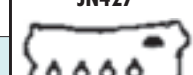

JN599

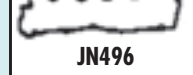

JN713

JM5292
4M41

NA5245 29x43x8mm
NA5243 50x74x11mm

JC272

JN365
(50-026768-00)

JJ075

KJ577 (x4) [202]
KJ211 (x8)

NJ242 35x50x8mm, NBR
NJ005 44x60x7mm, NBR
NJ006 72x96x9mm, FPM/ACM

NJ255 [70]

JC612

JN496
(50-026768-00)

JJ274

NJ242 35x50x8mm, NBR
NJ005 44x60x7mm, NBR
NJ251 80x96x9mm, MVQ

HBS307®
(22-76004B)
M12x1.25x104mm (x10)

JC224

JN403
(50-026769-00)

JJ072

KJ211 (x8)

NJ242 35x50x8mm, NBR
NJ005 44x60x7mm, NBR
NJ251 80x96x9mm, MVQ

NJ255 [70]
NJ610 [15]

JC224

JN403
(50-026769-00)

JJ072

JN427
(50-028227-00)

JJ072

KJ211 (x8)

NJ334 23x34x8mm, ACM
NJ057 48x68x11mm, ACM
NJ251 80x96x9mm, MVQ

JC969
JC751

JN713 (x2)
(50-028201-00)

KJ211 (x12)

NJ242 (x2) 35x50x8mm, NBR
NJ874 37x50x6mm, ACM
NJ873 91x111x9mm, FPM

JC632

JN599
(50-026767-00)

KJ211 (x8)

NJ242 35x50x8mm, NBR
NJ251 80x96x9mm, MVQ

NJ255 [70]
NJ655 [70]

JC612

JN496
(50-026768-00)

JJ274

NJ242 35x50x8mm, NBR
NJ005 44x60x7mm, NBR
NJ251 80x96x9mm, MVQ

NJ255 [70]
NJ655 [70]

JC969
JC751

JN713 (x2)
(50-028201-00)

KJ211 (x12)

NJ242 (x2) 35x50x8mm, NBR
NJ874 37x50x6mm, ACM
NJ873 91x111x9mm, FPM

JN713
(50-028201-00)
JN889 (x2)

PA968 (x24)

JN713
(50-028201-00)
JN889 (x2)

PA968 (x24)

HM5239

NK143 85x103x8mm, FPM

MITSUBISHI



KW/PS



Space Gear 2.0L 16V				05/95 → 05/00	198	AA5390 (Graphite)	CA5390	FA5390
4 G 63	1997	4	85.00	SOHC	83-110/ 113- 150	08/96 →	08/96 →	
Space Gear 2.4L i				05/95 → 05/00	199	AG8080 (Graphite)	CG8080	
Space Gear 2.4L i 4x4				05/95 → 05/00				
4 G 64	2350	4	86.50	MPI, SOHC	91-97/ 124- 132			
Space Gear 2.5L TD Diesel				05/95 → 05/00	200	BS130 (Graphite), 1.50mm	DS130	GS130
Space Gear 2.5L TD 4x4 Diesel				05/95 → 05/00		(30-028225-00)	(21-28225-20/0)	(20-28225-00/0)
4 D 56 T	2476	4	91.10	SOHC	63/85			
4 D 56 TD	2477	4	91.10	Indirect Injection, SOHC	73/99			
Space Runner 1.8L				10/91 → 08/99	201	BT890 (Graphite)	DT890	
Space Runner 1.8L 4x4				10/91 → 08/99		(30-028919-00)		
4 G 93	1834	4	81.00	Injection, DOHC	85-110/ 116- 150			
Space Runner 2.0L				08/99 →	202	AG5140 (Fibre), 1.3mm	CG5400	EG6280
Space Runner 2.0L 16V				06/97 → 08/99				FA5390
4 G 63	1997	4	85.00	SOHC	83-110/ 113- 150			
Space Runner 2.0L TD GLX Diesel				10/92 → 08/99	203	AG5302 (Graphite), 1.40mm, 1 Hole	CG5520▲	
4 D 68 T	1998	4	82.70	SOHC	60/81	AG5300 (Graphite), 1.45mm, 2 Holes AG5301 (Graphite), 1.5mm, 3 Notches 4D68T		
Space Runner 2.4L GDI				08/99 →	204	AG9120 (MLS)	CG9120	
4G64 (GDI)	2351	4	86.50	Injection, DOHC	110/150	01/94 →		
Space Star 1.3L 16V				06/98 →	205	AG7690 (MLS)	CG7691	FF5470
4 G 13 (16 V)	1299	4	71.00	Injection, SOHC	63/86	4G13		
Space Star 1.3L 16V				09/00 →	206	AG7690 (MLS)	CG7691	FF5470
4 G 13 (16 V)	1299	4	71.00	Injection, SOHC	63/86	4G13		
Space Star 1.6L 16V				09/01 →	207	AF5480 (MLS)	CF5481	
4G18	1584	4	76.00	DOHC	72/98			
Space Star 1.8L GDI				06/98 →	208	AE5610 (MLS)	CE5612	FG7710
4 G 93	1834	4	81.00	Injection, DOHC	85-110/ 116- 150	4G93		4G93
Space Star 1.9L DI-D Diesel				02/01 →	209	AC5070 (Fibre), 1.35mm, 2 Notches	CC5060▲	EC5060
F9Q1	1870	4	80.00	Direct Injection, SOHC	75/102	(30-029474-00)	(21-29483-20/0)	(22-29474-00/0)
F9Q2	1870	4	80.00	Direct Injection, SOHC	85/116	→0.653mm AC5080 (Fibre), 1.45mm, 1 Notch (30-029475-00) →0.653 → 0.786mm AC5090 (Fibre), 1.55mm, 3 Notches (30-029476-00) →0.786mm →		
Space Wagon 1.8L				10/91 → 10/98	210	BT890 (Graphite)	DT890	
Space Wagon 1.8L 4x4				10/91 → 10/98		(30-028919-00)		
4 G 93	1834	4	81.00	Injection, DOHC	85-110/ 116- 150			

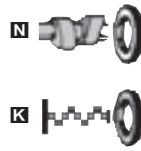
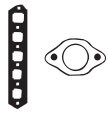

AC5070, AC5080,
AC5090



BS130



BT890



JC224

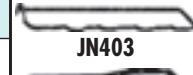

JN403



JJ072

		HM5239			<input checked="" type="checkbox"/> NK143 85x103x8mm, FPM	
	JD131	HM5239			<input checked="" type="checkbox"/> NK143 85x103x8mm, FPM	
HBS295 <i>(22-70013B)</i> M12x1.25x104mm (x18)	JC224	JN403 <i>(50-026769-00)</i>	JJ072			
HBS215 <i>(22-76001B)</i> M10x1.25x95mm (x10)	JD5781				<input checked="" type="checkbox"/> NK143 85x103x8mm, FPM	
	JD131	HM5239			<input checked="" type="checkbox"/> NK143 85x103x8mm, FPM	
HBS421 <i>(22-76024B)</i> M11x1.25x118mm (x10)					<input checked="" type="checkbox"/> NK143 85x103x8mm, FPM	
HBS477 <i>(22-75009B)</i>		HM5244 (NBR) 4G13				
		HM5244 (NBR) 4G13				
HBS477 <i>(22-75009B)</i>						
HBS215 <i>(22-76001B)</i> M10x1.25x95mm (x10)		JM5232 4G93			<input checked="" type="checkbox"/> NK143 85x103x8mm, FPM	
HBS120 <i>(22-51008B)</i> M12x1.50x118mm (x10)	JD5189	JM5086	JH5041	HR646 24-30670-60/0	<input checked="" type="checkbox"/> NF846 25x42x7mm, FPM/ACM <i>(50-319516-00)</i> <input checked="" type="checkbox"/> NA5036 42x54x6mm, FPM <i>(50-319473-00)</i> <input checked="" type="checkbox"/> NF850 85x105x8mm, FPM <i>(50-319183-00)</i>	HL5017 [245]
HBS215 <i>(22-76001B)</i> M10x1.25x95mm (x10)	JD5781				<input checked="" type="checkbox"/> NK143 85x103x8mm, FPM	











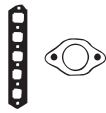

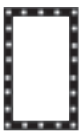

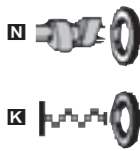





















































































MITSUBISHI



KW/PS



Space Wagon 1.8L		01/84 → 01/87		211	BM830 (Fibre) (30-026721-10)	DM830 (21-26721-21/0)	GM830
G37B	1755	4	80.60	SOHC	61-62/ 83-84		
Space Wagon 1.8L 4x4		10/87 → 08/88		212	BM830 (Fibre) (30-026721-10)	DM831	
Space Wagon 1.8L GLX		01/84 → 12/88					
4 G 37	1755	4	80.60	Carburettor, SOHC	63-71/ 86-97		
Space Wagon 1.8L D Diesel		01/84 → 12/89		213	BN220 (Graphite) (30-026722-10)	DN221	GN221
Space Wagon 1.8L TD Diesel		06/86 → 10/98					
4 D 65 T	1796	4	80.60	with balance shafts, Indirect Injection, SOHC, Turbo	55-60/ 75-82		
4 D 65 T	1796	4	80.60	Indirect Injection, SOHC	55-60/ 75-82		
Space Wagon 1.8L Turbo		→ 04/84		214	BL450 (Graphite)	DL452	
4 G 62 BT	1795	4	80.60	SOHC, Turbo			
Space Wagon 2.0L GDI		04/02 →		215			FA5390
4 G 63	1997	4	85.00	SOHC	83-110/ 113- 150		
Space Wagon 2.0L		→ 12/88		216	BH060 (Graphite) (30-026723-10)	DH064	GH064
4 G 63 T	1997	4	85.00	Injection, SOHC, Turbo	110/150		
Space Wagon 2.0L 4x4		03/85 → 04/91		217	BH060 (Graphite) (30-026723-10)	DH061 (21-26723-23/0)	GH061
4 G 63	1997	4	85.00	SOHC	66-101/ 90-137		
Space Wagon 2.0L GLX		06/86 → 05/88		218	BH060 (Graphite) (30-026723-10)	DH062	GH062 (20-26723-00/0)
Space Wagon 2.0L GLX 4x4		06/86 → 05/88					
G63B	1997	4	85.00	SOHC	62-75/ 84-102		
Space Wagon 2.0L GLXi		06/88 → 04/91		219	BH060 (Graphite) (30-026723-10)	DH061 (21-26723-23/0)	GH061
4 G 63	1997	4	85.00	SOHC	66-101/ 90-137		
Space Wagon 2.0L GLXi		10/92 → 10/98		220	AG5140 (Fibre), 1.3mm	CG5400	EG6280 FA5390
Space Wagon 2.0L GLXi 4x4		10/92 → 10/98					
4 G 63	1997	4	85.00	SOHC	83-110/ 113- 150		
Space Wagon 2.0L TD GLX Diesel		10/92 → 10/98		221	AG5302 (Graphite), 1.40mm, 1 Hole AG5300 (Graphite), 1.45mm, 2 Holes AG5301 (Graphite), 1.5mm, 3 Notches 4D68T	CG5520▲	EG6280
4 D 68 T	1998	4	82.70	SOHC	60/81		
Space Wagon 2.4L GDI		09/00 →		222	AG9120 (MLS) 01/94 →		
4G64 (GDI)	2351	4	86.50	Injection, DOHC	110/150		
Space Wagon 2.4L GDI		10/98 →		223	AG9130 (MLS), 0.4mm	CG9120	
Space Wagon 2.4L GDI 4x4		10/98 →			AG9120 (MLS) 01/94 →	CG9130	
4G64 (GDI)	2351	4	86.50	Injection, DOHC	110/150		
Space Wagon 2.4L i		10/92 → 10/98		224		CG9120	
	2351	4			102/139		
Starion 2.0L		01/85 → 12/93		225	BH060 (Graphite) (30-026723-10)	DH061 (21-26723-23/0)	GH061
4 G 63	1997	4	85.00	SOHC	66-101/ 90-137		
Starion Coupe 2.0L Turbo ECI		06/82 → 08/87		226	BH060 (Graphite) (30-026723-10)	DH064	GH064
4 G 63 T (ECI)	1997	4	85.00	Injection	125/170		
4 G 63 T/C	1997	4	85.00	Injection	132/180		

								
		JC272 	JN365 (50-026766-00)	JJ075	KJ577 (x4) [202] KJ211  (x8)	 NJ242 35x50x8mm, NBR  NJ005  44x60x7mm, NBR  NJ006  72x96x9mm, FPM/ACM		NJ255 [70]
		JC968  JC627 	JN365 (50-026766-00) HL502  (24-26766-00/0)		KJ211  (x8)	 NJ242 35x50x8mm, NBR  NJ005  44x60x7mm, NBR  NJ006  72x96x9mm, FPM/ACM		
HBS307  (22-76004B) M12x1.25x104mm (x10)	JC632 	JN599 (50-026767-00)			KJ211  (x8)	 NJ242 35x50x8mm, NBR  NJ251  80x96x9mm, MVQ		NJ255 [70] NJ655 [70]
	JC493  JC441  09/81 → JC611  06/83 →	JN496 (50-026768-00) →01/82	JJ274		KJ577 (x4) [202] KJ211  (x8)	 NJ242 35x50x8mm, NBR  NJ005  44x60x7mm, NBR  NJ251  80x96x9mm, MVQ		NJ255 [70] NJ655 [70] NJ610 [15]
	JC493  JC441 	JN496 (50-026768-00)	JJ274		KJ577 (x4) [202] KJ211  (x8)	 NJ242 35x50x8mm, NBR  NJ005  44x60x7mm, NBR  NJ251  80x96x9mm, MVQ		NJ655 [70]
HBS307  (22-76004B) M12x1.25x104mm (x10)	JC493 	JN496 (50-026768-00)	JJ274		KJ577 (x4) [202]  KJ211  (x4)	 NJ242 (x2) 35x50x8mm, NBR  NJ005  44x60x7mm, NBR  NJ251  80x96x9mm, MVQ		NJ655 [70]
HBS307  (22-76004B) M12x1.25x104mm (x10)	JC612  JC611 	JN496 (50-026768-00)	JJ274			 NJ242 35x50x8mm, NBR  NJ005  44x60x7mm, NBR  NJ251  80x96x9mm, MVQ		NJ255 [70] NJ655 [70]
	JC493 	JN496 (50-026768-00)	JJ274		KJ577 (x4) [202]  KJ211  (x4)	 NJ242  (x2) 35x50x8mm, NBR  NJ005  44x60x7mm, NBR  NJ251  80x96x9mm, MVQ		NJ655 [70]
HBS354  (22-76006B) M11x1.25x97mm (x10)	JD131 	HM5239 				 NK143  85x103x8mm, FPM		
HBS421 (22-76024B) M11x1.25x118mm (x10)						 NK143  85x103x8mm, FPM		
	JD131 	HM5239 				 NK143  85x103x8mm, FPM		
	JC493 	JN496 (50-026768-00)	JJ274		KJ577 (x4) [202]  KJ211  (x4)	 NJ242  (x2) 35x50x8mm, NBR  NJ005  44x60x7mm, NBR  NJ251  80x96x9mm, MVQ		NJ655 [70]
HBS307  (22-76004B) M12x1.25x104mm (x10)	JC493  JC441 	JN496 (50-026768-00)	JJ274		KJ577 (x4) [202] KJ211  (x8)	 NJ242 35x50x8mm, NBR  NJ005  44x60x7mm, NBR  NJ251  80x96x9mm, MVQ		NJ655 [70]

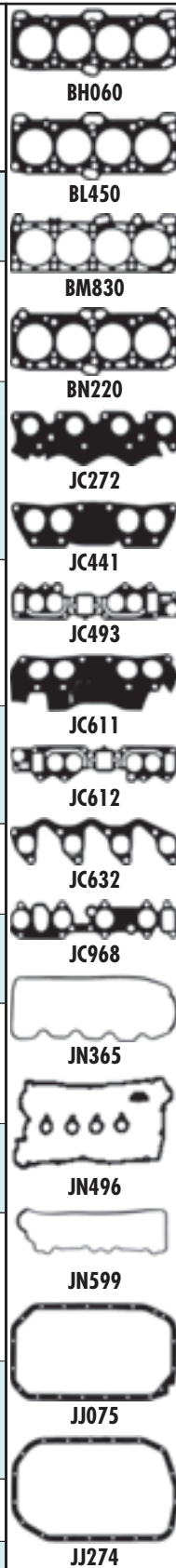

MITSUBISHI



KW/PS



Starion 2.6L		01/82 → 12/88			227	BJ890 (Graphite)		
G54B	2555	4	91.10		76-114/ 103- 155	(30-028226-00)		
Tredia 1.6L GLS		09/82 → 10/87			228	BK410 (Graphite)		
Tredia 1.6L Turbo		09/82 → 05/85						
4G32	1597	4	76.90	SOHC	48-55/ 65-75			
4G32 T	1597	4	76.90	SOHC	84-85/ 114- 116			
Tredia 1.6L Turbo		01/84 → 12/88			229	BK410 (Graphite)		
G32BT	1597	4	76.90	SOHC, Turbo	77/105			
Tredia 1.8L		01/84 →			230	BM830 (Fibre)	DM830	GM830
Tredia 1.8L GLS		08/84 → 07/86				(30-026721-10)	(21-26721-21/0)	
G37B	1755	4	80.60	SOHC	61-62/ 83-84			
4 G 37	1755	4	80.60	Carburettor, SOHC	63-71/ 86-97			
Tredia 1.8L Turbo		08/84 → 07/86			231	BL450 (Graphite)	DL452	
G62B	1796	4	80.60	SOHC	100/136			
Tredia 2.0L		01/84 → 12/88			232	BH060 (Graphite)	DH062	GH062
G63B	1997	4	85.00	SOHC	62-75/ 84-102	(30-026723-10)		(20-26723-00/0)
Verada 3.0L 24V		10/92 → 05/99			233			FG6120
6 G 72	2972	6	91.10	Injection, DOHC, V6	123- 151/ 167- 205			

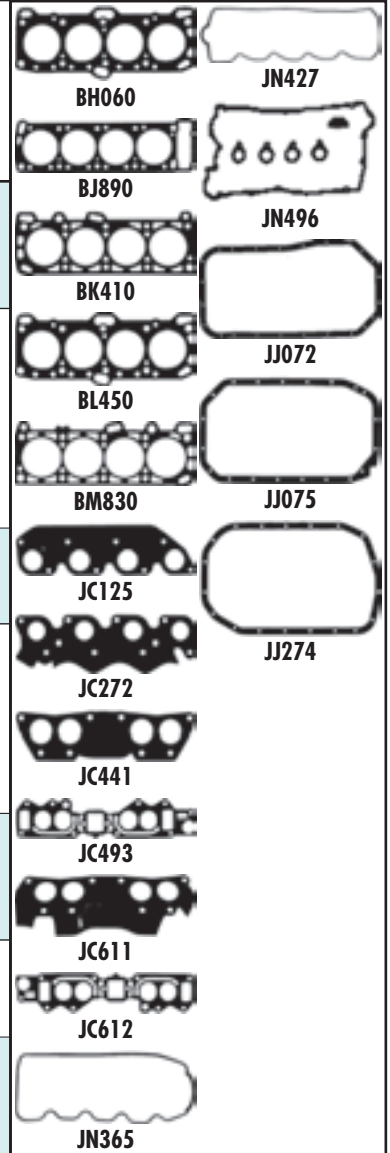
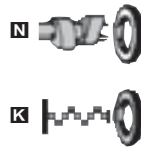
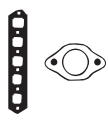

	JC125	JN427 (50-028227-00)	JJ072		NJ334 23x34x8mm, ACM	
		JN365 (50-026766-00)	JJ075	KJ577 (x4) [202] KJ211 (x8)	NJ242 35x50x8mm, NBR NJ005 44x60x7mm, NBR NJ006 72x96x9mm, FPM/ACM	NJ255 [70]
	JC272	JN365 (50-026766-00) HL502 (24-26766-00/0)	JJ075	KJ577 (x4) [202] KJ211 (x8)	NJ242 35x50x8mm, NBR NJ005 44x60x7mm, NBR NJ006 72x96x9mm, FPM/ACM	NJ255 [70]
	JC493 JC441 →12/85 JC611	JN496 (50-026768-00)	JJ274	KJ577 (x4) [202] KJ211 (x8)	NJ242 35x50x8mm, NBR NJ005 44x60x7mm, NBR NJ251 80x96x9mm, MVQ	NJ255 [70]
	JC612 JC611	JN496 (50-026768-00)	JJ274		NJ242 35x50x8mm, NBR NJ005 44x60x7mm, NBR NJ251 80x96x9mm, MVQ	NJ255 [70] NJ655 [70]



KW/PS



1100 1.1L				01/66 → 12/72	1	AF070 (Fibre) [121] (30-027570-00)	CF070 ■	EF075 [125] EF07C [124]
A Series	1098	4	64.56					
Ital 1.5L D Diesel				01/80 → 12/84	2	AE780 (Fibre)		EE781 [12]
1.5 Litre	1489	4	73.00					
Ital 1.7L				07/80 → 03/84	3	BD970 (Fibre)		
O Series	1698	4	84.44		58/79			
Ital 2.0L				07/80 → 03/84	4	BD970 (Fibre)		
O Series	1994	4	84.44		67/91			
Marina 1.5L D Diesel				10/78 → 10/80	5	AE780 (Fibre)		EE781 [12]
1.5 Litre	1489	4	73.00		37/50			
Marina 1.7L				11/78 → 06/80	6	BD970 (Fibre)		
	1698	4			58/79			
Marina Coupe 1800 TC				04/71 → 12/75	7	AK660 (Fibre) (30-027581-00)	CK663 ■ [240] [241] CK665 ■ Canada USA	
B Series	1798	4	80.25		57/78			
Mini 850				01/63 → 12/79	8	AF070 (Fibre) [121] (30-027570-00)	CF070 ■	EF075 [125]
A Series	848	4	62.92					
Mini 1000				01/75 → 12/82	9	AF070 (Fibre) [121] (30-027570-00)	CF070 ■	EF075 [125] → 12/78 EF07C [124] 01/79 →
A Series	998	4	64.56					
Minor 1100				01/63 → 12/69	10	AF070 (Fibre) [121] (30-027570-00)	CF070 ■	EF070 → Eng.10MA/U/H181785 EF074 Eng.10MA/U/H18178610 → Eng.10ME & 10V →
A Series	1098	4	64.56					
Oxford 1.5L D Diesel				01/63 → 12/70	11	AE780 (Fibre)	CE780 ■	EE781 [12]
1.5 Litre	1489	4	73.00					
Oxford 1.6L Series VI				01/61 → 12/66	12	AD950 (Fibre) [121]	CD950 ■	
1.6AMW/1.6GE/1.6RA	1622	4	76.18	B Series, Carburettor				

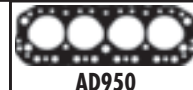
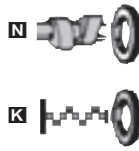
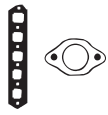

AD950



AE780



AF070



AK660



BD970



JA282



JA439



JM302



JM315



KT005



















HC031



JH396

		JA439	JM302 <i>(31-027568-00)</i> KT005 (x2) [126]	HC031	HR619	NA473 39.7x59x9.5mm, NBR NA584 55x70x10mm, MVQ	NA301 [2] NB684 [38] HJ013 [39] NB083 [42] [120] JR264 [11] [124]
			JM315		HR618 [193]	NA473 39.7x59x9.5mm, NBR	NA295 [42]
					HR625	NB586 30x40x7mm, MVQ NB772 88.9x104.8x9.52mm, MVQ	
				JH396	HR625	NB586 30x40x7mm, MVQ NB772 88.9x104.8x9.52mm, MVQ	
			JM315		HR618 [193]	NA473 39.7x59x9.5mm, NBR	
					HR625	NB586 30x40x7mm, MVQ NB772 88.9x104.8x9.52mm, MVQ	
		JA282	JM315 KT005 (x2) [126]		HR618 [193]	NA473 39.7x59x9.5mm, NBR NB772 88.9x104.8x9.52mm, MVQ	
		JA439	JM302 <i>(31-027568-00)</i> KT005 (x2) [126]	HC031	HR619	NA473 39.7x59x9.5mm, NBR NA584 55x70x10mm, MVQ	NA448 [2] NA301 [2] NB684 [38] HJ013 [39] NB083 [42] [120]
		JA439	JM302 <i>(31-027568-00)</i> KT005 (x2) [126]	HC031	HR619	NA473 39.7x59x9.5mm, NBR NA584 55x70x10mm, MVQ	NA448 [2] NA301 [2] NB684 [38] HJ013 [39] NB083 [42] [120] JR264 [11] [124]
		JA439	JM302 <i>(31-027568-00)</i> KT005 (x2) [126]	HC048	HR619	NA473 39.7x59x9.5mm, NBR NA584 55x70x10mm, MVQ	NA301 [2]
			JM315		HR618 [193]	NA473 39.7x59x9.5mm, NBR	NA295 [42]
		JA282	JM315		HR618 [193]	NA473 39.7x59x9.5mm, NBR	

		CC			9			CC			9
301 (28/46)	Petrol	1490	4	84.00	86	E15S	Petrol	1488	4	76.00	224
301.00	Petrol	1186	4	80.00	83	E15S	Petrol	1488	4	76.00	252
A12	Petrol	1171	4	73.00	82	E15S	Petrol	1488	4	76.00	254
A15	Petrol	1488	4	76.00	292	E15S	Petrol	1488	4	76.00	85
A15S	Petrol	1488	4	76.00	253	E15T	Petrol	1488	4	76.00	112
A15S	Petrol	1488	4	76.00	39	E15T	Petrol	1488	4	76.00	216
CA16D	Petrol	1598	4	78.00	261	E15T	Petrol	1488	4	76.00	87
CA16DE	Petrol	1598	4	78.00	219	E16	Petrol	1597	4	76.00	217
CA16S	Petrol	1598	4	78.00	243	E16i	Petrol	1597	4	76.00	258
CA16S	Petrol	1598	4	78.00	41	E16i	Petrol	1597	4	76.00	259
CA18	Petrol	1809	4	83.00	244	E16i	Petrol	1597	4	76.00	265
CA18	Petrol	1809	4	83.00	47	E16S	Petrol	1597	4	76.00	258
CA18D	Petrol	1809	4	83.00	241	E16S	Petrol	1597	4	76.00	259
CA18D	Petrol	1809	4	83.00	269	F4R 720	Petrol	1998	4	82.70	194
CA18D	Petrol	1809	4	83.00	49	F4R 722	Petrol	1998	4	82.70	194
CA18DE	Petrol	1809	4	83.00	270	F9Q 760	Diesel	1870	4	80.00	192
CA18ET	Petrol	1809	4	83.00	236	F9Q 762	Diesel	1870	4	80.00	192
CA18ET	Petrol	1809	4	83.00	46	F9Q 772	Diesel	1870	4	80.00	103
CA18N	Petrol	1809	4	83.00	48	G9T 722	Diesel	2188	4	87.00	104
CA18S	Petrol	1809	4	83.00	113	G9U 720	Diesel	2463	4	89.00	105
CA18S	Petrol	1809	4	83.00	188	G9U 730	Diesel	2463	4	89.00	195
CA18S	Petrol	1809	4	83.00	240	GA14DE	Petrol	1392	4	73.60	21
CA18S	Petrol	1809	4	83.00	244	GA14DE	Petrol	1392	4	73.60	250
CA18S	Petrol	1809	4	83.00	44	GA14DS	Petrol	1392	4	73.60	250
CA18T	Petrol	1809	4	83.60	50	GA14S	Petrol	1392	4	73.60	251
CA20	Petrol	1973	4	84.50	114	GA15E	Petrol	1497	4	73.60	255
CA20	Petrol	1973	4	84.50	53	GA16	Petrol	1597	4	76.00	218
CA20E	Petrol	1974	4	84.50	189	GA16	Petrol	1597	4	76.00	225
CA20E	Petrol	1974	4	84.50	237	GA16DE	Petrol	1597	4	76.00	196
CA20E	Petrol	1974	4	84.50	245	GA16DE	Petrol	1597	4	76.00	200
CA20E	Petrol	1974	4	84.50	56	GA16DE	Petrol	1597	4	76.00	201
CA20E	Petrol	1974	4	84.50	57	GA16DE	Petrol	1597	4	76.00	230
CA20E	Petrol	1974	4	84.50	8	GA16DE	Petrol	1597	4	76.00	24
CA20P	Petrol	1973	4	84.50	74	GA16DE	Petrol	1597	4	76.00	260
CA20S	Petrol	1974	4	84.50	117	GA16DE	Petrol	1597	4	76.00	262
CA20S	Petrol	1974	4	84.50	190	GA16DE	Petrol	1597	4	76.00	266
CA20S	Petrol	1974	4	84.50	52	GA16DE	Petrol	1597	4	76.00	293
CA20S	Petrol	1974	4	84.50	73	GA16DE	Petrol	1597	4	76.00	6
CD17	Diesel	1680	4	80.00	20	GA16DEL	Petrol	1597	4	76.00	260
CD17	Diesel	1680	4	80.00	220	GA16DEL	Petrol	1597	4	76.00	262
CD17	Diesel	1680	4	80.00	227	GA16DEL	Petrol	1597	4	76.00	266
CD17	Diesel	1680	4	80.00	267	GA16DS	Petrol	1597	4	76.00	198
CD17	Diesel	1680	4	80.00	88	GA16DS	Petrol	1597	4	76.00	199
CD20	Diesel	1974	4	84.50	209	GA16DS	Petrol	1597	4	76.00	226
CD20	Diesel	1974	4	84.50	271	GA16DS	Petrol	1597	4	76.00	260
CD20	Diesel	1974	4	84.50	272	GA16DS	Petrol	1597	4	76.00	262
CD20	Diesel	1974	4	84.50	29	GA16DS	Petrol	1597	4	76.00	264
CD20T	Diesel	1974	4	84.50	212	GA16DS	Petrol	1597	4	76.00	5
CD20T	Diesel	1974	4	84.50	37	GA16i	Petrol	1597	4	76.00	263
CG10DE	Petrol	998	4	71.00	134	K4M 752	Petrol	1598	4	79.50	111
CG10DE	Petrol	998	4	71.00	135	K9K 700	Diesel	1461	4	76.00	149
CG13DE	Petrol	1275	4	71.00	139	K9K 704	Diesel	1461	4	76.00	110
CGA3DE	Petrol	1348	4	82.80	142	K9K 704	Diesel	1461	4	76.00	144
CGA3DE	Petrol	1348	4	82.80	89	K9K 722	Diesel	1461	4	76.00	109
CR12DE	Petrol	1240	4	71.00	138	K9K 722	Diesel	1461	4	76.00	144
CR14DE	Petrol	1386	4	73.00	140	K9K 722	Diesel	1461	4	76.00	23
CR14DE	Petrol	1386	4	73.00	141	KA24DE	Petrol	2389	4	89.00	122
CR14DE	Petrol	1386	4	73.00	148	KA24DE	Petrol	2389	4	89.00	13
CR14DE	Petrol	1386	4	73.00	90	KA24DE	Petrol	2389	4	89.00	150
D4F 712	Petrol	1149	4	69.00	108	KA24DE	Petrol	2389	4	89.00	172
D7F 764	Petrol	1149	4	69.00	107	KA24DE	Petrol	2389	4	89.00	288
E13	Petrol	1270	4	76.00	215	KA24DE	Petrol	2389	4	89.00	31
E13	Petrol	1270	4	76.00	246	KA24DE	Petrol	2389	4	89.00	40
E13	Petrol	1270	4	76.00	247	KA24DE	Petrol	2389	4	89.00	72
E13	Petrol	1270	4	76.00	249	KA24DE	Petrol	2389	4	89.00	98
E13	Petrol	1270	4	76.00	84	KA24E	Petrol	2389	4	89.00	100
E13S	Petrol	1269	4	76.00	248	KA24E	Petrol	2389	4	89.00	14
E15	Petrol	1488	4	76.00	256	KA24E	Petrol	2389	4	89.00	174
E15S	Petrol	1488	4	76.00	187	KA24E	Petrol	2389	4	89.00	175

		CC			9			CC			9
KA24E	Petrol	2389	4	89.00	191	SD23	Diesel	2289	4	89.00	170
KA24E	Petrol	2389	4	89.00	238	SD23	Diesel	2289	4	89.00	171
KA24E	Petrol	2389	4	89.00	275	SD23	Diesel	2289	4	89.00	287
KA24E	Petrol	2389	4	89.00	38	SD23	Diesel	2289	4	89.00	65
L16	Petrol	1595	4	83.00	2	SD25	Diesel	2488	4	89.00	102
L16	Petrol	1595	4	83.00	43	SD25	Diesel	2488	4	89.00	179
L18	Petrol	1770	4	85.00	166	SD25	Diesel	2488	4	89.00	180
L20B	Petrol	1952	4	85.00	3	SD25	Diesel	2488	4	89.00	67
L24	Petrol	2393	6	83.00	118	SD33	Diesel	3246	6	83.00	164
L24E	Petrol	2393	6	83.00	119	SR20DE	Petrol	1998	4	86.00	1
L24E	Petrol	2393	6	83.00	4	SR20DE	Petrol	1998	4	86.00	10
L24E	Petrol	2393	6	83.00	58	SR20DE	Petrol	1998	4	86.00	123
L24S	Petrol	2393	6	83.00	119	SR20DE	Petrol	1998	4	86.00	205
L28	Petrol	2753	6	86.00	155	SR20DE	Petrol	1998	4	86.00	206
L28	Petrol	2753	6	86.00	156	SR20DE	Petrol	1998	4	86.00	210
L28	Petrol	2753	6	86.00	157	SR20DE	Petrol	1998	4	86.00	211
L28E	Petrol	2753	6	86.00	120	SR20DE	Petrol	1998	4	86.00	229
L28E	Petrol	2753	6	86.00	75	SR20DE	Petrol	1998	4	86.00	231
L28E	Petrol	2753	6	86.00	94	SR20DE	Petrol	1998	4	86.00	234
L28S	Petrol	2753	6	86.00	101	SR20DE	Petrol	1998	4	86.00	273
L28S	Petrol	2753	6	86.00	159	SR20DE	Petrol	1998	4	86.00	28
LD20	Diesel	1952	4	85.00	116	SR20DE	Petrol	1998	4	86.00	7
LD20	Diesel	1952	4	85.00	232	SR20DE	Petrol	1998	4	86.00	9
LD20	Diesel	1952	4	85.00	233	SR20DET	Petrol	1998	4	86.00	11
LD20	Diesel	1952	4	85.00	295	SR20DET	Petrol	1998	4	86.00	274
LD20	Diesel	1952	4	85.00	296	SR20DI (SPI)	Petrol	1998	4	86.00	207
LD20	Diesel	1952	4	85.00	54	SR20DI (SPI)	Petrol	1998	4	86.00	208
LD20	Diesel	1952	4	85.00	55	TB42E	Petrol	4169	6	96.00	165
LD20II	Diesel	1952	4	85.00	294	TD15 (TUD5)	Diesel	1527	4	77.00	143
LD20T	Diesel	1952	4	85.00	62	TD23	Diesel	2289	4	89.00	286
LD23	Diesel	2283	4	84.50	235	TD23	Diesel	2289	4	89.00	64
LD23	Diesel	2283	4	84.50	297	TD23	Diesel	2289	4	89.00	65
M1D	Diesel	1994	4	84.00	222	TD25	Diesel	2494	4	92.90	177
M9R	Diesel	1995	4	84.00	222	TD25	Diesel	2494	4	92.90	178
MA10	Petrol	988	4	68.00	133	TD25	Diesel	2494	4	92.90	290
MA10S	Petrol	988	4	68.00	131	TD25	Diesel	2494	4	92.90	66
MA10S	Petrol	988	4	68.00	132	TD25TI	Diesel	2494	4	92.90	178
MA12	Petrol	1235	4	71.00	137	TD27	Diesel	2663	4	96.00	182
MA12S	Petrol	1235	4	71.00	136	TD27	Diesel	2663	4	96.00	183
MR20DE	Petrol	1997	4	84.00	223	TD27	Diesel	2663	4	96.00	283
MR20DE	Petrol	1997	4	84.00	299	TD27	Diesel	2663	4	96.00	291
MR20DE	Petrol	1997	4	84.00	51	TD27	Diesel	2663	4	96.00	69
QG15DE	Petrol	1498	4	73.60	22	TD27T	Diesel	2663	4	96.00	277
QG16DE	Petrol	1597	4	76.00	197	TD27T	Diesel	2663	4	96.00	278
QG16DE	Petrol	1597	4	76.00	257	TD27T	Diesel	2663	4	96.00	70
QG16DE	Petrol	1597	4	76.00	34	TD27TI	Diesel	2664	4	96.00	277
QG16DE	Petrol	1597	4	76.00	42	VG30DETT	Petrol	2960	6	87.00	18
QG18DE	Petrol	1769	4	80.00	202	VG30E	Petrol	2960	6	87.00	12
QG18DE	Petrol	1769	4	80.00	228	VG30E	Petrol	2960	6	87.00	127
QG18DE	Petrol	1769	4	80.00	25	VG30E	Petrol	2960	6	87.00	15
QG18DE	Petrol	1769	4	80.00	26	VG30E	Petrol	2960	6	87.00	184
QG18DE	Petrol	1769	4	80.00	268	VG30E	Petrol	2960	6	87.00	239
QG18DE	Petrol	1769	4	80.00	27	VG30E	Petrol	2960	6	87.00	281
QG18DE	Petrol	1769	4	80.00	35	VG30E	Petrol	2960	6	87.00	80
QG18DE	Petrol	1769	4	80.00	45	VG30E	Petrol	2960	6	87.00	95
QG18DE	Petrol	1769	4	80.00	93	VG30ET	Petrol	2960	6	87.00	16
QR20DE	Petrol	1998	4	89.00	204	VG30ET	Petrol	2960	6	87.00	79
QR20DE	Petrol	1998	4	89.00	300	VG30ET	Petrol	2960	6	87.00	97
QR20DE	Petrol	1998	4	89.00	36	VG30I	Petrol	2960	6	87.00	152
QR25DE	Petrol	2488	4	89.00	214	VG30I	Petrol	2960	6	87.00	78
QR25DE	Petrol	2488	4	89.00	303	VG30I	Petrol	2960	6	87.00	96
RB20E	Petrol	1998	6	78.00	242	VG30T	Petrol	2960	6	87.00	17
RD28	Diesel	2825	6	85.00	121	VG33E	Petrol	3275	6	91.50	153
RD28	Diesel	2825	6	85.00	158	VG33E	Petrol	3275	6	91.50	186
RD28	Diesel	2825	6	85.00	76	VG33E	Petrol	3275	6	91.50	282
RD28	Diesel	2825	6	85.00	99	VG33E	Petrol	3275	6	91.50	92
RD28T	Diesel	2826	6	85.00	160	VQ20DE	Petrol	1995	6	76.00	124
RD28T	Diesel	2826	6	85.00	77	VQ20DE	Petrol	1995	6	76.00	125
RD28Ti	Diesel	2826	6	85.00	161	VQ30DE	Petrol	2988	6	93.00	126



CC



9



CC



9

VQ30DE	Petrol	2988	6	93.00	128
VQ30DE	Petrol	2988	6	93.00	129
VQ35	Petrol	3498	6	95.50	154
VQ35DE	Petrol	3498	6	95.50	130
VQ35DE	Petrol	3498	6	95.50	146
VQ35DE	Petrol	3498	6	95.50	147
VQ35DE	Petrol	3498	6	95.50	19
VQ35DE	Petrol	3498	6	95.50	32
VQ35DE	Petrol	3498	6	95.50	81
YD22DDT	Diesel	2184	4	86.00	213
YD22DDT	Diesel	2184	4	86.00	30
YD22DDTi	Diesel	2184	4	86.00	30
YD22DDTi	Diesel	2184	4	86.00	301
YD22ETi	Diesel	2184	4	86.00	302
YD25DDTi	Diesel	2488	4	89.00	181
Z16	Petrol	1595	4	83.00	59
Z16S	Petrol	1595	4	83.00	33
Z20	Petrol	1952	4	85.00	167
Z20	Petrol	1952	4	85.00	168
Z20	Petrol	1952	4	85.00	284
Z20	Petrol	1952	4	85.00	285
Z20	Petrol	1952	4	85.00	60
Z20	Petrol	1952	4	85.00	61
Z20S	Petrol	1952	4	85.00	115
Z22	Petrol	2187	4	87.00	169
Z22	Petrol	2187	4	87.00	63
Z24i	Petrol	2389	4	89.00	176
Z24i	Petrol	2389	4	89.00	276
Z24i	Petrol	2389	4	89.00	289
Z24i	Petrol	2389	4	89.00	298
Z24S	Petrol	2388	4	89.00	151
Z24S	Petrol	2388	4	89.00	173
ZD30	Diesel	2953	4	96.00	106
ZD30	Diesel	2953	4	96.00	185
ZD30	Diesel	2953	4	96.00	279
ZD30	Diesel	2953	4	96.00	71
ZD30	Diesel	2953	4	96.00	91
ZD30DDTi	Diesel	2953	4	96.00	162
ZD30DDTi	Diesel	2953	4	96.00	280



KW/PS



100 NX 2.0L						10/90 → 10/94	1	BV540 (Fibre)	CY250■ DV540■	EV540 GV540
SR20DE	1998	4	86.00	DOHC	92-118/ 125- 160					
510 1.6L							2	AJ050 (Fibre)	CJ051■	FJ051
L16	1595	4	83.00	SOHC	64/87					
810 2.0L						01/76 → 12/78	3	AJ490 (Graphite)	CJ491■	FJ491
L20B	1952	4	85.00	SOHC	81/110					
810 2.4L						01/81 →	4	AJ580 (Graphite)	CJ586■	
L24E	2393	6	83.00	SOHC	94/128					
100 NX Coupe 1.6L						03/90 → 10/94	5	BP970 (Graphite)	DP970 (21-28244-20/0)	GP970 (20-28244-00/0)
GA16DS	1597	4	76.00	DOHC						
100 NX Coupe 1.6L SR						09/93 → 10/94	6	BP960 (Graphite) (30-028243-00) BP970 (Graphite) BV440 (Fibre) 01/94 →	DP960 (21-28243-20/0) DV440 01/94 →	GP960 (20-28243-00/0) GV440 01/94 →
GA16DE	1597	4	76.00	MPi, DOHC	66-75/ 90-102					
100 NX Coupe 2.0L GTI						03/91 → 10/94	7	BV540 (Fibre)	CY250■ DV540■	EV540 GV540
SR20DE	1998	4	86.00	DOHC	92-118/ 125- 160					
200 SX 2.0L						01/84 →	8	BM760 (Graphite) (30-026733-10) → 12/88		GM760 → 06/86
CA20E	1974	4	84.50	Injection, SOHC	72-85/ 98-116					
200 SX Coupe 2.0L i 16V						10/93 → 12/99	9	BV540 (Fibre)	CY250■ DV540■	EV540 GV540
SR20DE	1998	4	86.00	DOHC	92-118/ 125- 160					
200 SX Coupe 2.0L i 16V						07/88 → 11/93	10	BV540 (Fibre)	CY250■ DV540■	GV540
SR20DE	1998	4	86.00	DOHC	92-118/ 125- 160					
200 SX Coupe 2.0L i 16V Turbo						10/93 → 12/99	11	BV540 (Fibre)	DV540■	EV540
SR20DET	1998	4	86.00		147/200					
200 SX 3.0L SX						01/86 →	12	BM570 (Graphite) (x2) (30-028270-00) → 12/87	DM570 → 12/86 DM574 01/88 →	
VG30E	2960	6	87.00	Injection, SOHC	95-125/ 129- 170					
240 SX 2.4L						05/94 → 08/97	13	BV310 (Graphite)	DV311	GV311
KA24DE	2389	4	89.00	DOHC	98-110/ 133- 150					
240 SX 2.4L							14	BS770 (Graphite) (30-028258-00) → 12/90	DS770■ → 12/90 DS771■ (21-28258-21/0)	GS771
KA24E	2389	4	89.00	Injection, SOHC	85-98/ 116- 133					
300 ZX 3.0L						01/84 → 12/87	15	BM570 (Graphite) (x2) (30-028270-00)	DM570 → 12/86 DM574 01/88 →	
VG30E	2960	6	87.00	Injection, SOHC	95-125/ 129- 170					

HBS188 ® [22-70002B] M11x1.50x157mm (x10)	JD134 ■ JC760 ■	JN798		HR768 ■ ■ HR767 ■ ■	NJ106 ■ 40x62x10mm, NBR NJ284 ■ 84x104x11mm, FPM	
	JA008 	JM005	JH005	PA933 ■ (x8)	NJ045 ■ 48x70x9mm, NBR NJ278 ■ 45x68x12mm, NBR NJ056 ■ 80x100x13mm, MVQ	HG037 [43]■
	JA007 	JM005	JH005	PA933 ■ (x8)	NJ045 ■ 48x70x9mm, NBR NJ056 ■ 80x100x13mm, MVQ	HG037 [43]■
	JC128	JM044	JH031	PA933 ■ (x12)	NJ045 ■ 48x70x9mm, NBR NJ056 ■ 80x100x13mm, MVQ	HG037 [43]■
HBS187 ® [22-70001B] M10x1.50x97mm (x10)	JD093 ■ JD091 ■ (x2)	JN838 (50-028284-00)		PB681 (x16)	NJ207 29x49x7.5mm, ACM NJ765 ■ 40x52x7mm, NBR NJ284 ■ 84x104x11mm, FPM	
HBS187 ® [22-70001B] M10x1.50x97mm (x10)	JC999 ■ JD001 ■ JC761 JD110 JD091 ■ (x2)	JN829 (50-028283-00)	JH5100		NJ207 29x49x7.5mm, ACM NJ765 ■ 40x52x7mm, NBR NJ284 ■ 84x104x11mm, FPM NJ222 ■ 40x52x7mm, FPM 01/94 →	
HBS188 ® [22-70002B] M11x1.50x157mm (x10)	JD134 ■ JC760 ■	JN798		HR768 ■ ■ HR767 ■ ■	NJ106 ■ 40x62x10mm, NBR NJ284 ■ 84x104x11mm, FPM	
	JC605 ■ →12/88 JD029 ■ →12/87 JC475 ■ (x2) →12/88	JN433 →12/87 JN624 01/88 →	HC459 ■ JJ265 →12/87 JJ367 01/86 → JJ368 06/86 →	PA079 ■ (x8)	NJ285 34x48x8mm, NBR NJ280 ■ 33x47x8mm, NBR NJ284 ■ 84x104x11mm, FPM	
HBS188 ® [22-70002B] M11x1.50x157mm (x10)	JD134 ■ JC760 ■	JN798		HR768 ■ ■ HR767 ■ ■	NJ106 ■ 40x62x10mm, NBR NJ284 ■ 84x104x11mm, FPM	
HBS188 ® [22-70002B] M11x1.50x157mm (x10)	JD134 ■ JC760 ■	JN798		HR768 ■ ■ HR767 ■ ■	NJ106 ■ 40x62x10mm, NBR NJ284 ■ 84x104x11mm, FPM	
HBS188 ® [22-70002B] M11x1.50x157mm (x10)		JN798				
HBS404 [22-70018B]	JC581 ■ (x2) JC471 ■ JC472 ■	JN570 (x2)	JJ299 →12/87 HC460 ■ 01/88 →	PA933 ■ (x6) PA079 ■ (x6)	NJ285 (x2) 34x48x8mm, NBR NJ368 ■ 33x47x7mm, NBR NJ284 ■ 84x104x11mm, FPM	NJ885 [2]■ 06/87 → KA675 [13] →12/87
	JC997 ■	JN880 HM5268 ■		PA079 (x16)	NK106 ■ 46x58x7mm, ACM	
	JC901 ■ JC900 ■	JN743 (50-028304-00)		PA933 ■ (x8) PA079 ■ (x8)	NK106 ■ 46x58x7mm, ACM	
HBS404 [22-70018B]	JC581 ■ (x2) JC471 ■ JC472 ■	JN570 (x2)	JJ299 →12/87 HC460 ■ 01/88 →	PA933 ■ (x6) PA079 ■ (x6)	NJ285 (x2) 34x48x8mm, NBR NJ368 ■ 33x47x7mm, NBR NJ284 ■ 84x104x11mm, FPM	NJ885 [2]■ 06/87 → KA675 [13] 07/83 →12/87

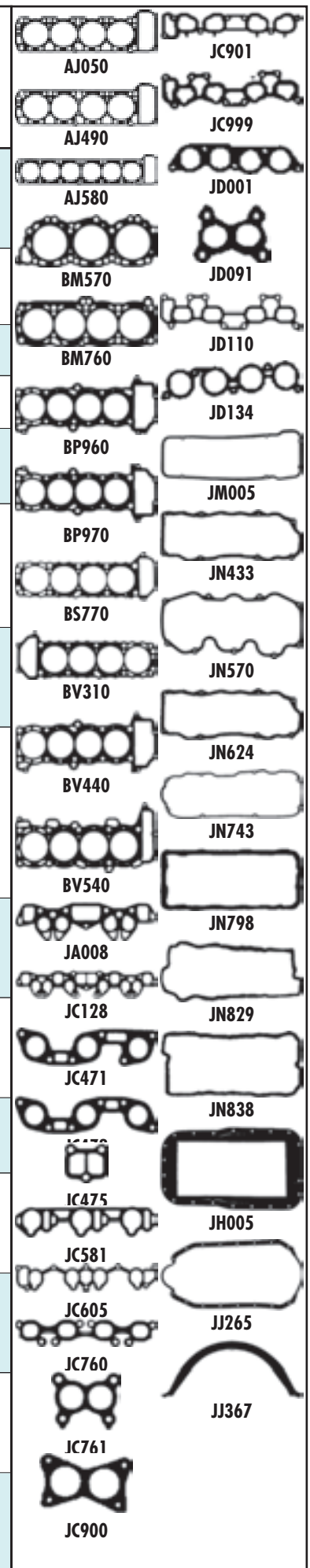





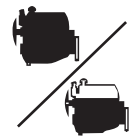



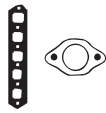

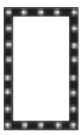

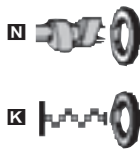



















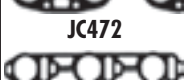













































KW/PS



300 ZX 3.0L Turbo				05/87 → 10/90	16	BM570 (Graphite) (x2) (30-028270-00)	DM574 01/88 →	
VG30ET	2960	6	87.00	Injection, SOHC, V6	149/203			
300 ZX 3.0L Turbo				04/84 → 10/90	17	BM570 (Graphite) (x2) (30-028270-00) 10/86 →	DM574 01/88 →	
VG30T	2960	6	87.00	SOHC, V6	169/230			
300 ZX Coupe 3.0L Twin Turbo				05/90 → 09/95	18	BS910 (Graphite) (x2)	DS910	GS910
VG30DETT	2960	6	87.00	Injection, V6	197- 208/ 268- 283			
350 Z 3.5L				03/05 →	19	AE5910 (MLS)	CG6130	EG8230
350 Z Coupe 3.5L				10/03 →		AG6130 (MLS)		
VQ35DE	3498	6	95.50	DOHC, V6	206/280			
AD Van 1.7L D Diesel				05/99 →	20	BP580 (Graphite), 1,20mm (30-026734-10)		
CD17	1680	4	80.00	SOHC	40/54			
Almera 1.4L				09/95 → 07/00	21	BP950 (Graphite) (30-028874-00)	DP951	
Almera 1.4L GX,LX				09/95 → 07/00				
Almera 1.4L S,GX,LX				09/95 → 03/00				
GAT4DE	1392	4	73.60	DOHC	55-64/ 75-87			
Almera 1.5L				03/00 →	22	AD5250 (MLS), 0.6mm	CD5250	
QG15DE	1498	4	73.60	Injection, DOHC	66-80/ 90-109			
Almera 1.5L dCi Diesel				01/03 →	23	AE5200 (MLS) (30-029015-00) → 05/04 AG9490 (MLS) (30-029497-00) 05/04 →	CE5200▲ (21-29015-20/0)	
K9K 722	1461	4	76.00	Direct Injection, SOHC	60/82			
Almera 1.6L				09/95 → 07/00	24	BP960 (Graphite) (30-028243-00) BV440 (Fibre)	DV440	GV440
Almera 1.6L SLX				09/95 → 07/00				
Almera 1.6L SR,SLX				09/95 → 03/00				
GAT6DE	1597	4	76.00	MPi, DOHC	66-75/ 90-102			
Almera 1.8L				03/00 →	25	AB5610 (MLS)	CB5610 QG18DE	FB5610
QG18DE	1769	4	80.00	Injection, DOHC	84-93/ 114- 126			
Almera 1.8L				12/02 →	26	AG7820 (MLS) AG7810 (MLS)	CG7810	
QG18DE	1769	4	80.00	Injection, DOHC	84-93/ 114- 126			
Almera 1.8L Mk I				07/95 → 05/00	27	AB5690 (MLS)	CB5610	FB5610
Almera 1.8L Mk II				01/02 →				
QG18DE	1769	4	80.00	Injection, DOHC	84-93/ 114- 126			

								
HBS404 (22-70018B)	JC581  01/86→ JC471  10/86→ JC472  10/86→  JF018 01/88→	JN570 01/86→	JJ299 10/86→04/87 HC460  01/88→	PA079 (x6) PA933 (x6)	 NJ285 (x2) 34x48x8mm, NBR  NJ368  33x47x7mm, NBR  NJ284  84x104x11mm, FPM			 AE5200  BM570  BP580  BP950  BP960  BS910  BV440  JC471  JC472  JC581  JC761  JC999  JD001  JD091  JD110  JN570  JN829
HBS404 (22-70018B)	JC581  (x2) 01/86→ JC471  10/86→ JC472  10/86→  JF018 01/88→	JN570 (x2) 01/86→	JJ299 10/86→04/87 HC460  01/88→	PA933  (x6) 01/86→ PA079  (x6) 01/86→	 NJ285 (x2) 34x48x8mm, NBR  NJ368  33x47x7mm, NBR 01/86→  NJ284  84x104x11mm, FPM 01/86→	KA675 [13] 01/84→04/84		
			HC460 	PA874  (x24)	 NJ765 40x52x7mm, NBR  NJ765  40x52x7mm, NBR  NJ284  84x104x11mm, FPM			
HBS404 (22-70018B)		JM5316  JM5317 						
HBS187  (22-70001B) M10x1.50x97mm (x10)				PB681 (x16)	 NJ765  40x52x7mm, NBR  NJ284  84x104x11mm, FPM			
HBS422 (22-70020B) M10x1.50x92mm (x10)		JM5064						
HBS299  (22-29019B) M11x1.50x125.0mm (x10)	JD5402  (31-030008-00)			HR817  24-30614-78/0	 NA5215 28x42x5mm, FPM  NA5255  35x47x7mm	HL5026 [245] 		
HBS187  (22-70001B) M10x1.50x97mm (x10)	JC999  JD001  JC761 JD110 JD091  (x2)	JN829 (50-028283-00)			 NJ222  40x52x7mm, FPM  NJ284  84x104x11mm, FPM			
HBS422 (22-70020B) M10x1.50x92mm (x10)		JM5245 QG18DE						
		JM5294  JM5293 						
HBS422 (22-70020B) M10x1.50x92mm (x10)		JM5245						



KW/PS

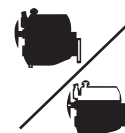

Almera 2.0L						08/00 →	28	AG5190 (Fibre), 1.3mm	DV542	EV540
Almera 2.0L GTi						07/96 →03/00				
SR20DE	1998	4	86.00	DOHC		92-118/ 125- 160				
Almera 2.0L D Diesel						11/95 →07/00	29	BW420 (MLS) (30-028861-00) AD5280 (MLS), 1.15mm, 1 Hole →01/96 AD5281 (MLS), 1.25mm, 3 Notches →01/96 CD20	CD5280▲ →01/96 DW420	GW420 GW421▲
CD20	1974	4	84.50			55/75				
Almera 2.2L dCi Diesel						09/03 →	30	AD5260 (MLS), 0.8mm, 1 Hole	CD5260▲	
Almera 2.2L Di Diesel						03/00 →				
YD22DDT	2184	4	86.00	Direct Injection, DOHC		81-102/ 110- 139				
YD22DDTi	2184	4	86.00	Direct Injection, DOHC		84-100/ 114- 136				
Altima 2.4L						06/93 →09/01	31	BV310 (Graphite)	DV311	GV311
KA24DE	2389	4	89.00	DOHC		112/152 98-110/ 133- 150				
Altima 3.5L						08/01 →09/06	32		CG5882	
VQ35DE	3498	6	95.50	DOHC, V6		206/280				
Atlas 1.6L						01/86 →	33	BM820 (Graphite)	DM821■	GM821
Z16S	1595	4	83.00	SOHC						
Avenir 1.6L						11/97 →	34	AB5690 (MLS)	CB5630	FB5610
QG16DE	1597	4	76.00	DOHC		78-80/ 106- 109				
Avenir 1.8L						11/97 →	35	AB5690 (MLS)	CB5611	FB5610
QG18DE	1769	4	80.00	Injection, DOHC		84-93/ 114- 126				
Avenir 2.0L						09/01 →	36		CF5541	FF5541
Avenir 2.0L 4x4						09/01 →				
QR20DE	1998	4	89.00	DOHC		103- 110/ 140- 150				
Avenir 2.0L TD Diesel						11/97 →09/99	37			GW421▲
CD20T	1974	4	84.50	SOHC		66/90				
Axxess 2.4L						01/89 →12/92	38	BS770 (Graphite) (30-028258-00) →12/90	DS770■ →12/90 DS771■ (21-28258-21/0)	GS771
KA24E	2389	4	89.00	Injection, SOHC		85-98/ 116- 133				
B310 1.5L						01/80 →	39	BC270 (Graphite)	DC271■	GC272
A15S	1488	4	76.00			51/69				
Bassara 2.4L						11/99 →08/02	40	BV310 (Graphite)	DV311	GV311
KA24DE	2389	4	89.00	DOHC		98-110/ 133- 150				

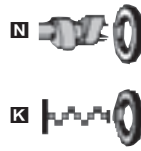
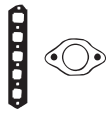

BC270



BM820



BS770



BV310



BW420



JC057



JC126



JC133



JC760



JC900



JC901



JM008



JM086



JN743



JH005

HBS188 ® (22-70002B) M11x1.50x157mm (x10)	JC760 ■				NJ284 ■ 84x104x11mm, FPM	
HBS111 ® (22-70006B) M11x1.50x119mm (x10)	JD5761	JM5138	HC5011 ■			
HBS374 ® (22-70012B) M11x1.25x109mm (x10)		JM5137		PA5020 (x16) (50-319496-00)	NJ369 ■ 58x80x12mm, MVQ NA5090 ■ 76x94x8.5mm, FPM (50-319499-00)	
		HM5268 ■		PA079 (x16)		
	JC126 ■ JC133 ■ (x2)	JM086 (50-028281-00)	JH005	PA933 ■ (x8)	NJ045 ■ 48x70x9mm, NBR NJ056 ■ 80x100x13mm, MVQ	HG037 [43]■
	JC901 ■ JC900 ■	JN743 (50-028304-00)		PA933 ■ (x8) PA079 ■ (x8)	NK106 ■ 46x58x7mm, ACM	
	JC057	JM008 (31-026183-00)	HC259 ■	KJ454 (x8)	NJ022 ■ 38x55x9mm, FPM/ACM NJ004 ■ 60x82x12mm, FPM/ACM	HG034 [43]■
	JC997 ■	JN880 HM5268 ■		PA079 (x16)	NK106 ■ 46x58x7mm, ACM	



KWPS



Bluebird 1.6L 12/85 → 06/90 41						BK830 (Graphite)	DM596	GM596
CA16S	1598	4	78.00	Injection, SOHC	60-66/ 82-90	BM590 (Graphite) (30-028247-00)		
Bluebird 1.6L 08/00 → 08/05 42							CB5630	
QG16DE	1597	4	76.00	DOHC	78-80/ 106- 109			
Bluebird 1.6L 43						AJ050 (Fibre)	CJ051 ■	FJ051
LT16	1595	4	83.00	SOHC	64/87			
Bluebird 1.8L 11/83 → 04/90 44						BK480 (Fibre) (30-024578-10)		
CA18S	1809	4	83.00	Injection, SOHC		BK840 (Graphite)		
Bluebird 1.8L 08/02 → 08/05 45						AB5690 (MLS)	CB5611	FB5610
Bluebird 1.8L 4x4 08/00 → 07/02								
QG18DE	1769	4	80.00	Injection, DOHC	84-93/ 114- 126			
Bluebird 1.8L 01/87 → 46						BM590 (Graphite) (30-028247-00)	DM597	GM597 ○ [12]
CA18ET	1809	4	83.00	Injection, SOHC, Turbo	90-100/ 122- 136			
Bluebird 1.8L 01/83 → 12/90 47						BM590 (Graphite) (30-028247-00)	DM596	GM596
CA18	1809	4	83.00	SOHC	65/88			
Bluebird 1.8L 05/86 → 48						BK840 (Graphite)		
CA18N	1809	4	83.00	SOHC	65/88			
Bluebird 1.8L i 16V 02/89 → 12/90 49						BM590 (Graphite) (30-028247-00)	DM596	ER241
CA18D	1809	4	83.00	DOHC	92-95/ 125- 129	BS050 (Graphite) (30-028249-00)		
Bluebird 1.8L Turbo 04/84 → 05/90 50						BM590 (Graphite) (30-028247-00)	DM593 07/86 →	
CA18T	1809	4	83.60	Injection, SOHC	99/135			
Bluebird 2.0L 09/05 → 51								
MR20DE	1997	4	84.00	Injection, DOHC	98/133			
Bluebird 2.0L 12/85 → 09/90 52						BM760 (Graphite) (30-026733-10)		
CA20S	1974	4	84.50	Injection, SOHC	66-78/ 90-106			
Bluebird 2.0L 01/84 → 12/88 53						BM760 (Graphite) (30-026733-10)	DM761 → 01/86 DM765 01/86 → 07/86	GM761 (20-26733-00/0) → 01/86 GM765 07/86 →
CA20	1973	4	84.50	SOHC				
Bluebird 2.0L D Diesel 04/84 → 01/88 54						BR360 (Graphite) (30-028364-00)	DR360 (21-28364-20/0) 01/86 →	GR360 01/86 →
LD20	1952	4	85.00		43-49/ 58-67			
Bluebird 2.0L D Diesel 03/86 → 12/90 55						BR360 (Graphite) (30-028364-00)	DR360 (21-28364-20/0)	GR360
LD20	1952	4	85.00		43-49/ 58-67			

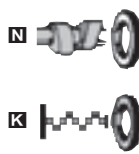
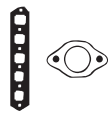

AJ050



BK480



BK830



BK840



BM590



BM760



BR360



BS050



JA008



JC317



JC475



JC605



JM005

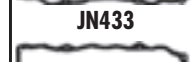

JN433

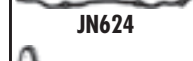

JN624



JN723



JH005



JJ265



JJ367







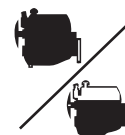



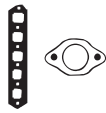

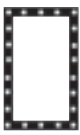

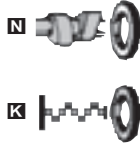









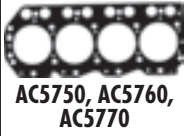

















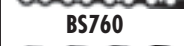

















































































	JC317 JC475 (x2) JE747	JN624	HC459 JJ265	PA079 (x8)	NJ285 34x48x8mm, NBR NJ280 33x47x8mm, NBR NJ284 84x104x11mm, FPM	NJ692 [2] NJ838 [2] NJ844 [2] NJ689 [38]
	JA008 JE014	JM005	JH005	PA933 (x8)	NJ045 48x70x9mm, NBR NJ056 80x100x13mm, MVQ	HG037 [43]
	JC317 JC475 (x2)	JN624	JJ265 →06/86 HC459 07/86 →	PA079 (x8)	NJ285 34x48x8mm, NBR NJ280 33x47x8mm, NBR NJ284 84x104x11mm, FPM	
	JC605 JC475	JN433	HC459 JJ367 JJ368	PA079 (x8)	NJ285 34x48x8mm, NBR NJ280 33x47x8mm, NBR NJ284 84x104x11mm, FPM	NJ213 [2]
	JC317 JC475 (x2)	JN624	JJ265 JJ367 JJ368	PA079 (x8)	NJ285 34x48x8mm, NBR NJ280 33x47x8mm, NBR NJ284 84x104x11mm, FPM	
	JC317 JC475 (x2) JE747	JN624	HC459 JJ265	PA079 (x8)	NJ285 34x48x8mm, NBR NJ280 33x47x8mm, NBR NJ284 84x104x11mm, FPM	NJ692 [2] NJ838 [2] NJ844 [2]
	JC605 JC475 (x2)	JN624	JJ265 →06/86 HC459 07/86 → JJ368 07/86 → JJ367 1987 →	PA079 (x8)	NJ285 34x48x8mm, NBR NJ280 33x47x8mm, NBR NJ284 84x104x11mm, FPM	NJ213 [2] 10/83 →
	JD5891 JD5892	HM5290				
	JC605 JC475 (x2) JE747	JN433	JJ265	PA079 (x8)	NJ280 33x47x8mm, NBR NJ284 84x104x11mm, FPM	NJ688 [38]
	JC605 →01/86 JC317 01/86 →07/86 JC475 (x2)	JN624	JJ265 →07/86 JJ367 HC459 07/86 →	PA079 (x8)	NJ285 34x48x8mm, NBR NJ280 33x47x8mm, NBR NJ284 84x104x11mm, FPM	
	JD5760 JE747	JN722 →12/85 JN723 01/86 →	JH5097	PA933 (x8)	NJ045 48x70x9mm, NBR NJ056 80x100x13mm, MVQ	
	JD5760 JE747	JN723	JH5097	PA933 (x8)	NJ045 48x70x9mm, NBR NJ056 80x100x13mm, MVQ	

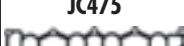

KW/PS



Model	Year	Cyl	CC	Injection	SOHC	Power (KW/PS)	Head	Seal	Notes	
Bluebird 2.0L i	04/84 → 12/90					56	BM760 (Graphite)	DM766	GM766	
CA20E	1974	4	84.50	Injection, SOHC		72-85/ 98-116	(30-026733-10)			
Bluebird 2.0L i	09/88 → 09/90					57	BM760 (Graphite)	DM766	GM766	
CA20E	1974	4	84.50	Injection, SOHC		72-85/ 98-116	(30-026733-10)			
Bluebird 2.4L Maxima	01/81 →					58	AJ580 (Graphite)	CJ586 ■		
L24E	2393	6	83.00	SOHC		94/128				
Cabstar 1.6L	10/86 → 09/92					59	BM820 (Graphite)	DM821 ■	GM821	
Z16	1595	4	83.00	SOHC		62/84				
Cabstar 2.0L	01/86 → 09/92					60	BG720 (Graphite)	DG724	GG724	
Z20	1952	4	85.00	SOHC		64/87	(21-28250-20/0)			
Cabstar 2.0L	01/86 → 06/92					61	BG720 (Graphite)	DG724	GG724	
Z20	1952	4	85.00	SOHC		64/87	(21-28250-20/0)			
Cabstar 2.0L D Diesel	01/82 → 12/87					62	BL310 (Graphite)			
LD20T	1952	4	85.00	Indirect Injection		57-60/ 78-82				
Cabstar 2.2L	10/86 → 06/92					63	BJ350 (Fibre)			
Z22	2187	4	87.00	SOHC		71/96				
Cabstar 2.3L Diesel	12/81 → 06/92					64	BS760 (MLS), 1.40mm	DS760 ■	GS760	
TD23	2289	4	89.00	Indirect Injection		51-56/ 69-76				
Cabstar 2.3L D Diesel	12/81 → 06/92					65	BL770 (Graphite)	DM580 ■	GL770	
SD23	2289	4	89.00	Indirect Injection		50-51/ 68-69	(30-028366-00)	(21-28257-20/0)	→ 12/83	
TD23	2289	4	89.00			51-56/ 69-76	→ 12/83 SD23 BS760 (MLS), 1.40mm TD23 BM580 (Steel Elastomer) (30-028257-00) 01/84 →	DM581 (21-28257-21/0) DS760 ■	GM580 GM581 GS760	
Cabstar 2.5L D Diesel	10/82 → 06/92					66	BW540 (MLS), 1.40mm	DW540 ■	GW540	
TD25	2494	4	92.90	Indirect Injection		55-61/ 75-83		(21-28889-20/0)		
Cabstar 2.5L D Diesel	02/83 → 12/90					67	BL770 (Graphite)	DL770	GL770	
SD25	2488	4	89.00	Indirect Injection		53-55/ 72-75	(30-028366-00)	→ 07/83	→ 07/83	
							→ 12/83 BM580 (Steel Elastomer) (30-028257-00) 01/84 →	DM580 ■ (21-28257-20/0) 08/83 → 07/85 DM581 (21-28257-21/0) 08/85 →	GM580 08/83 → 07/85 GM581 08/85 →	
Cabstar 2.5L D F22 Diesel	10/82 → 06/92					68	BW540 (MLS), 1.40mm	DW540 ■	GW540	
								(21-28889-20/0)		
Cabstar 2.7L D Diesel	02/83 → 12/90					69	BS200 (MLS), 1.40mm	DS200 ■	GS200	
TD27	2663	4	96.00	Indirect Injection		58-73/ 79-99	(30-028265-00)			
Cabstar 90.32 Diesel	10/98 → 10/06					70	AC5750 (MLS), 1.20mm, 1 Notch	CC5750 ▲		
TD27T	2663	4	96.00	Direct Injection		66-74/ 90-101	(30-029544-00)			
							AC5760 (MLS), 1.25mm, 2 Notches	(30-029545-00)		
							AC5770 (MLS), 1.30mm, 3 Notches	(30-029546-00)		
							BS200 (MLS), 1.40mm	(30-028265-00)		
Cabstar E 45.15 Diesel	10/06 →					71			FF5740 ▲	
ZD30	2953	4	96.00	Direct Injection		110/150				

									
		JC605  JC475 	JN624	HC459  JJ367 JJ368	PA079  (x8)	 NJ285 34x48x8mm, NBR  NJ280  33x47x8mm, NBR  NJ284  84x104x11mm, FPM		 AC5750, AC5760, AC5770  AJ580  BG720  BJ350  BL310  BL770  BM580  BM760  BM820  BS200  BS760  BW540  JC126  JC128  JC133  JC473  JC475  JC605  JC668  JC806  JM055	 JM086  JN416  JN624  JN724  JH005  JJ281  JJ367
		JC605  JC475  (x2)	JN624	HC459  JJ367 JJ368	PA079  (x8)	 NJ285 34x48x8mm, NBR  NJ280  33x47x8mm, NBR  NJ284  84x104x11mm, FPM			
		JC128	JM044	JH031	PA933  (x12)	 NJ045  48x70x9mm, NBR  NJ056  80x100x13mm, MVQ	HG037  [43] 		
		JC126  JC133  (x2)	JM086 (50-028281-00)	JH005	PA933  (x8)	 NJ045  48x70x9mm, NBR  NJ056  80x100x13mm, MVQ			
		JC126  JC133  (x2)	JM086 (50-028281-00)	JH005	PA933  (x8)	 NJ045  48x70x9mm, NBR  NJ056  80x100x13mm, MVQ			
		JC126  JC133  (x2)	JM086 (50-028281-00)	JH005	PA933  (x8)	 NJ045  48x70x9mm, NBR  NJ056  80x100x13mm, MVQ			
									
									
									
									
									
									
									
									
									
			JN416 (50-028298-00)						
									
									
									
									
									
		JC805  JC806 	JN724 (50-028308-00)		PA378	 NJ829 86x100x10mm, MVQ  NJ831 58x80x10mm, NBR			
		JC473 →07/85 JC668 08/85→	JM055 JN416 (50-028298-00) →07/83	JJ281	PA378 (x8)	 NJ369  58x80x12mm, MVQ  NJ287  80x100x10mm, MVQ			
									
									
									
									
									
									
									
									
									
									
									
									
									
									
									
									



KWPS

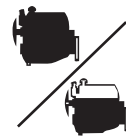

Model	Year Range	CC	Cyls	Power (kW)	Configuration	Power (CV)	Head	Engine	Accessories
Caravan 2.4L KA24DE	05/01 →	2389	4	89.00	DOHC	72 98-110/ 133- 150		BV310 (Graphite)	DV311
Cedric 2.0L CA20S	12/85 →12/87	1974	4	84.50	Injection, SOHC	73 66-78/ 90-106		BM760 (Graphite) (30-026733-10)	
Cedric 2.0L CA20P	06/83 →06/85	1973	4	84.50	SOHC	74		BM760 (Graphite) (30-026733-10)	
Cedric 2.0 L28E	04/82 →	2753	6	86.00	SOHC	75 103- 110/ 140- 150		BC380 (Graphite)	DC386 ■
Cedric 2.8L Diesel RD28	01/83 →	2825	6	85.00		76 66/89		BW620 (MLS)	DW620
Cedric 2.8L Turbo Diesel RD28T	08/92 →12/96	2826	6	85.00	SOHC, Turbo	77 85/116		BV250 (MLS), 1.50mm (30-028267-00)	DV250 (21-28267-20/0)
Cedric 3.0L VG30I	01/86 →	2960	6	87.00	Injection, SOHC	78 95/129		BM570 (Graphite) (x2) (30-028270-00)	DM577 1988 →
Cedric 3.0L Turbo VG30ET	01/88 →	2960	6	87.00	Injection, SOHC, Turbo, V6	79 149/203		BM570 (Graphite) (x2) (30-028270-00)	DM574
Cedric 3.0L V6 VG30E	01/83 →	2960	6	87.00	Injection, SOHC	80 95-125/ 129- 170		BM570 (Graphite) (x2) (30-028270-00)	DM570
Cefiro 3.5L VQ35DE	01/00 →09/03	3498 3498	6	95.50	DOHC, V6	81 170/231 206/280			CG5882
Cherry 1.2L Cherry Coupe 1.2L A12	08/78 →07/81 08/78 →07/81	1171	4	73.00	Injection	82 38/52		BN170 (Graphite)	DN170 ■
Cherry 1.2L 301.00	01/83 →12/85	1186	4	80.00		83 50/68		AA5540 (Fibre) (x2) (30-030087-00) AN350 (Fibre) (x2) (30-026481-00)	CN353 (21-26481-20/0)
Cherry 1.3L E13	05/82 →10/86	1270	4	76.00	SOHC	84 44/60		BK440 (Graphite) (30-026185-10) 01/83 →04/84	DK441 01/83 →04/84
Cherry 1.5L E15S	11/83 →10/86	1488	4	76.00	SOHC	85 52-55/ 71-75		BK440 (Graphite) (30-026185-10)	DK440 (21-26185-25/0)
Cherry 1.5L GTi 301 (28/46)	01/83 →12/85	1490	4	84.00	Injection, SOHC	86 77/105		BE620 (Fibre) (x2) (30-024362-10)	DE622 (21-24362-21/0)

		JC997	JN880 HM5268		PA079 (x16)	NK106 46x58x7mm, ACM		AA5540, AN350, BE620 BC380 BK440 BM570 BM760 BN170 BV250 BV310 BW620 JA898 JA899 JC317 JC471 JC472 JC475 JC507 JC581 JC605 JC745 JM008 JM669 JN433 JN494 JN570 JN588 JN665 JN837 JH565 JJ265 JA010 JA898 JA899 JC317 JC471 JC472 JC475 JC507 JC581 JC605 JC745
		JC605 JC475 JE747	JN433	JJ265	PA079 (x8)	NJ280 33x47x8mm, NBR NJ284 84x104x11mm, FPM	NJ688 [38]	
		JC317 JC475 (x2) JE747	JN433	JJ265	PA079 (x8)	NJ280 33x47x8mm, NBR NJ284 84x104x11mm, FPM		
HBS189 (22-70003B) M12x1.75x105.5mm (x18)			JM044	JH031			HG037 [43]	
HBS190 (22-70005B) M12x1.75x112mm (x14)			JN837 (50-028309-00)		PA079 (x12)	NJ285 34x48x8mm, NBR NJ765 40x52x7mm, NBR NJ287 80x100x10mm, MVQ		
HBS190 (22-70005B) M12x1.75x112mm (x14)			JN837 (50-028309-00)		PA079 (x12)	NJ285 34x48x8mm, NBR NJ765 40x52x7mm, NBR NJ287 80x100x10mm, MVQ		
	JC581 (x2) JC472 (x2)	JN570 (x2)	JJ299 HC460 1988 →		PA933 (x6) PA079 (x6)	NJ285 (x2) 34x48x8mm, NBR NJ368 33x47x7mm, NBR NJ284 84x104x11mm, FPM		
	JC581 (x2) JC471 JC472 JF018	JN570 (x2)	HC460 JJ299		PA933 (x6) PA079 (x6)	NJ285 34x48x8mm, NBR NJ368 33x47x7mm, NBR NJ284 84x104x11mm, FPM	KA675 [13]	
	JC581 (x2) JC471 JC472	JN570 (x2)	JJ299		PA933 (x6) PA079 (x6)	NJ285 (x2) 34x48x8mm, NBR NJ368 33x47x7mm, NBR NJ284 84x104x11mm, FPM	NJ885 [2] 06/87 →	
	JA010	JM008 (31-026183-00)	HC259			NJ022 38x55x9mm, FPM/ACM NJ021 60x82x12mm, NBR	NJ419 [2] NJ082 [2] NJ083 [2] HG034 [43]	
	JA898 (x2) JC507 (x2) JA899 (x4) (31-026340-10)	JM669 (31-023086-00) JN588 [207] (31-025164-10)	JH565	HR602 24-30670-61/0		NA5064 (x2) 35x58x10mm, ACM (50-306562-50) NB696 (x2) 35x58x10mm, ACM NB694 40x56x10mm, ACM (50-306664-50) NA5065 62x80x12mm, ACM	NJ419 [2] HJ287 [39]	
HBS409 (22-70017B)	HA366 01/83 → 04/84 JC745 05/82 → 12/86	JN494 01/83 → 04/84 JN665 01/83 → 04/84	HC442		PA203 (x8)	NJ288 40x55x9mm, NBR NJ286 36x49x7mm, NBR NJ287 80x100x10mm, MVQ		
HBS409 (22-70017B)	HA371 JC745 (x2)	JN494	HC442		PA203 (x8)	NJ288 40x55x9mm, NBR NJ286 36x49x7mm, NBR NJ287 80x100x10mm, MVQ	NJ419 [2] NJ552 [2] NJ639 [2]	
	JA898 (x2) JC507 (x2) JA899 (x2) (31-026340-10)	JM669 (31-023086-00) JN588 (31-025164-10)	JH565			NA5064 (x2) 35x58x10mm, ACM (50-306562-50) NB696 (x2) 35x58x10mm, ACM NB694 40x56x10mm, ACM (50-306664-50) NA5065 62x80x12mm, ACM	NJ419 [2] HJ287 [39]	



KW/PS

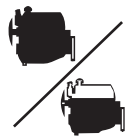

Model	Year Range	CC	Cylinders	Power (KW/PS)	Configuration	Head	Code	Head Code	Accessories	
Cherry 1.5L Turbo E15T	01/83 → 12/86	1488	4	76.00	Injection, SOHC, Turbo		87 77/105	BK440 (Graphite) (30-026185-10)	DK445 01/86 →	GK445 01/85 →
Cherry 1.7L D Diesel CD17	10/82 → 12/86	1680	4	80.00	SOHC		88 40/54	BP580 (Graphite), 1,20mm (30-026734-10)	DP581 → 12/86 DP580 01/87 →	GP581 → 12/86 GP580 01/87 →
Cube 1.3L Cube 1.3L Allrad CGA3DE	09/00 → 12/02	1348	4	82.80	DOHC		89 60/81	AG7880 (MLS)	CG7880	FG7880
Cube 1.4L Cube 1.4L 4x4 CR14DE	01/03 → 09/05	1386	4	73.00	DOHC		90 65/88			
Elgrand 3.0L D Diesel ZD30	04/03 →	2953	4	96.00	Direct Injection		91 110/150			FF5740 ▲
Elgrand 3.3L Elgrand 3.3L 4x4 VG33E	04/96 → 08/01	3275	6	91.50	SOHC, V6		92 110-125/ 150-170			FF5690
Expert 1.8L QG18DE	10/98 → 04/04	1769	4	80.00	Injection, DOHC		93 84-93/ 114-126	AB5690 (MLS)	CB5611	FB5610
Fairlady 2.8L L28E	09/82 →	2753	6	86.00	SOHC		94 103-110/ 140-150	BC380 (Graphite)	DC388 ■	GC388
Fairlady 3.0L VG30E	01/83 →	2960	6	87.00	Injection, SOHC		95 95-125/ 129-170	BM570 (Graphite) (x2) (30-028270-00) → 12/87	DM570 → 12/87 DM574 01/88 →	
Fairlady 3.0L VG30I	01/86 →	2960	6	87.00	Injection, SOHC		96 95/129	BM570 (Graphite) (x2) (30-028270-00)	DM577	GM577 GM572 1988 →
Fairlady 3.0L Turbo VG30ET	01/84 →	2960	6	87.00	Injection, SOHC, Turbo, V6		97 149/203	BM570 (Graphite) (x2) (30-028270-00)	DM574 01/88 →	
Gloria 2.4L KA24DE	05/99 → 08/04	2389	4	89.00	DOHC		98 98-110/ 133-150	BV310 (Graphite)	DV311	GV311
Gloria 2.8L Diesel RD28	01/83 →	2825	6	85.00			99 66/89	BW620 (MLS)	DW620	GW620
Hardbody 2.4L 12V KA24E		2389	4	89.00	Injection, SOHC		100 85-98/ 116-133	BS770 (Graphite) (30-028258-00) → 12/90	DS770 ■ → 12/90 DS771 ■ (21-28258-21/0)	GS771
Hardtop 2.8L L28S	01/87 → 12/90	2753	6	86.00	SOHC		101	BC380 (Graphite)		
Homer 2.5L Diesel SD25	02/82 → 12/87	2488	4	89.00			102 53-55/ 72-75	BL770 (Graphite) (30-028366-00) → 07/83	DL770 → 07/83	GL770 → 07/83







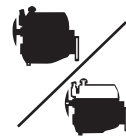



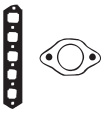

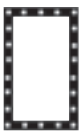

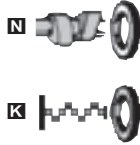













	HA371 JC745 01/84 → HA372 01/84 →	JN494	HC442	PA203 (x8)	NJ288 40x55x9mm, NBR NJ286 36x49x7mm, NBR NJ287 80x100x10mm, MVQ		BC380 BK440 BL770 BM570 BP580 BS770 BV310 BW620 JC128 JC471 JC472 JC473 JC581 JC745 JC900 JC901 JM055 JN494 JN528 JN570 JN743 JN837	JJ265 JJ281
		JN528	JJ265	PA079 (x8)	NJ283 36x50x8mm, NBR NJ285 34x48x8mm, NBR NJ280 33x47x8mm, NBR NJ284 84x104x11mm, FPM			
	JD5841 (FPM)							
	JD5841 (FPM)							
HBS189 (22-70003B) M12x1.75x105.5mm (x18)	JC128	JM044	JH031	PA933 (x12)	NJ045 48x70x9mm, NBR NJ056 80x100x13mm, MVQ	HG037 [43]		
	JC581 (x2) JC471 JC472	JN570 (x2)	JJ299	PA933 (x6) PA079 (x6)	NJ285 (x2) 34x48x8mm, NBR NJ368 33x47x7mm, NBR NJ284 84x104x11mm, FPM	KA675 [13] →12/87		
	JC581 (x2) JC472 (x2)	JN570 (x2)	JJ299 →12/87	PA933 (x6) PA079 (x6)	NJ285 (x2) 34x48x8mm, NBR NJ368 33x47x7mm, NBR NJ284 84x104x11mm, FPM			
	JC581 (x2) JC471 JC472 JF018 01/88 →	JN570 (x2) 01/86 →	JJ299 →04/87	PA933 (x6) PA079 (x6)	NJ285 (x2) 34x48x8mm, NBR NJ368 33x47x7mm, NBR NJ284 84x104x11mm, FPM	KA675 [13]		
	JC997	JN880 HMS268		PA079 (x16)	NK106 46x58x7mm, ACM			
HBS190 (22-70005B) M12x1.75x112mm (x14)		JN837 (50-028309-00)		PA079 (x12)	NJ285 34x48x8mm, NBR NJ765 40x52x7mm, NBR NJ287 80x100x10mm, MVQ			
	JC901 JC900	JN743 (50-028304-00)		PA933 (x8) PA079 (x8)	NK106 46x58x7mm, ACM			
	JC128	JM044	JH031	PA933 (x12)	NJ045 48x70x9mm, NBR NJ056 80x100x13mm, MVQ	HG037 [43]		
	JC473 →07/83	JM055 →07/83	JJ281 →07/83	PA378 (x8)	NJ369 58x80x12mm, MVQ NJ287 80x100x10mm, MVQ			



KWPS



Interstar 1.9L dCi 80	Diesel	07/02 →		103	AC5061 (MLS), 1.32mm (30-029473-10) AC5080 (Fibre), 1.45mm, 1 Notch (30-029475-00) →0.653 →0.786mm	CC5060▲ (21-29483-20/0)	EC5060 (22-29474-00/0)
F9Q 772	1870	4	80.00	Direct Injection, SOHC	60/82		
Interstar 2.2L dCi 90	Diesel	07/02 →		104	AE5210 (MLS), 1.24mm (30-029250-00)	CE5210	EE5220 (22-29037-00/0)
G9T 722	2188	4	87.00	Direct Injection, DOHC	66/90		
Interstar 2.5L dCi 120	Diesel	07/02 →		105	AA3130 (Fibre)	DP580	
G9U 720	2463	4	89.00	Direct Injection, DOHC	84/115		
Interstar 3.0L dCi 140	Diesel	11/03 →		106			FF5740▲
ZD30	2953	4	96.00	Direct Injection	110/150		
Kubistar 1.2L		08/03 →		107			
D7F 764	1149	4	69.00		44/60		
Kubistar 1.2L 16V		04/06 →		108	AD5980 (MLS) (30-029780-00)	CD5981	
D4F 712	1149	4	69.00	Injection	55/75		
Kubistar 1.5L dCi	Diesel	08/03 →		109	AE5200 (MLS) (30-029015-00) →05/04 AG9490 (MLS) (30-029497-00) 05/04 →	CE5200▲ (21-29015-20/0)	
K9K 722	1461	4	76.00	Direct Injection, SOHC	60/82		
Kubistar 1.5L dCi	Diesel	08/03 →		110	AE5200 (MLS) (30-029015-00) →05/04 AG9490 (MLS) (30-029497-00) 05/04 →	CE5200▲ (21-29015-20/0)	EE5200
Kubistar 1.5L dCi 70	Diesel	04/06 →					
Kubistar 1.5L dCi 85	Diesel	04/06 →					
K9K 704	1461	4	76.00	Direct Injection, SOHC	50/68 62/85 48/65		
Kubistar 1.6L 16V		08/03 →		111	AE5200 (MLS) (30-029015-00) →05/04 AG9490 (MLS) (30-029497-00) 05/04 →	CE5200▲ (21-29015-20/0)	EE5200
K4M 752	1598	4	79.50	DOHC	70/95		
Langley 1.5L Turbo		01/83 →12/86		112	BK440 (Graphite) (30-026185-10)		
E15T	1488	4	76.00	Injection, SOHC, Turbo	77/105		
Laurel 1.8L		08/82 →		113	BK840 (Graphite)		
CA18S	1809	4	83.00	Injection, SOHC			
Laurel 2.0L		01/83 →12/86		114	BM760 (Graphite) (30-026733-10)	DM769	
CA20	1973	4	84.50	SOHC			
Laurel 2.0L		01/82 →12/86		115	BG720 (Graphite)	DG724 (21-28250-20/0)	GG724
Z20S	1952	4	85.00		64-66/ 87-90		
Laurel 2.0L D Diesel		04/81 →10/84		116	BL310 (Graphite)		
LD20	1952	4	85.00		43-49/ 58-67		
Laurel 2.0L GL		11/84 →12/85		117		DH060	
CA20S	1974	4	84.50	Injection, SOHC	66-78/ 90-106		
Laurel 2.4L		09/83 →12/85		118	AJ580 (Graphite)	CJ586■	
L24	2393	6	83.00	Injection, SOHC	83-88/ 113- 120		

									
HBS120 Ⓢ (22-51008B) M12x1.50x118mm (x10)	JD5189	JM5086	JH5041 ● KG5012 16x23x1.5mm	HR646 Ⓢ 24-30670-60/0	NF846 25x42x7mm, FPM/ACM (50-319516-00) NA5036 Ⓢ 42x54x6mm, FPM (50-319473-00) NF850 Ⓢ 85x105x8mm, FPM (50-319183-00)	HL5017 [245]Ⓢ	AE5200 	JJ265 	
HBS373 Ⓢ (22-51110B) M12x1.50x131mm (x10)	JD5891 Ⓢ JD5892	HM5290 Ⓢ			NA5053 30x42x7mm, FPM (50-319488-00)		AE5210 	JJ367 	
	JD319 Ⓢ →12/01	HM5255 Ⓢ					AJ580 		
HBS241 Ⓢ (22-51102B) M9x1.25x103mm (x10)							BG720 		
HBS283 Ⓢ (22-72004B) M9x1.25x122mm (x10)					NA5261 28x47x8mm, PTFE		BK440 		
HBS299 Ⓢ (22-29019B) M11x1.50x125.0mm (x10)	JD5402 Ⓢ (31-030008-00) ● KK5643 (31-030009-00)			HR817 Ⓢ 24-30614-78/0	NA5215 28x42x5mm, FPM NA5255 Ⓢ 35x47x7mm	HL5026 [245]Ⓢ	BK840 		
HBS299 Ⓢ (22-29019B) M11x1.50x125.0mm (x10)	JD5402 Ⓢ (31-030008-00) ● KK5643 (31-030009-00)	JM7054 (NBR)	JH5109 (NBR)	HR817 Ⓢ 24-30614-78/0	NA5215 28x42x5mm, FPM NA5255 Ⓢ 35x47x7mm	HL5026 [245]Ⓢ	BL310 		
HBS299 Ⓢ (22-29019B) M11x1.50x125.0mm (x10)	JD5402 Ⓢ (31-030008-00) ● KK5643 (31-030009-00)	JM7054 (NBR)	JH5109 (NBR)	HR817 Ⓢ 24-30614-78/0	NA5215 28x42x5mm, FPM NA5255 Ⓢ 35x47x7mm	HL5026 [245]Ⓢ	BM760 		
	HA371 ⓈⓈ JC745 Ⓢ HA372 ⓈⓈ	JN494	HC442 Ⓢ	PA203 (x8)	NJ288 40x55x9mm, NBR NJ286 Ⓢ 36x49x7mm, NBR NJ287 Ⓢ 80x100x10mm, MVQ		JC126 		
	JC317 Ⓢ	JN433	JJ265	PA079 Ⓢ (x8)	NJ285 34x48x8mm, NBR NJ280 Ⓢ 33x47x8mm, NBR NJ284 Ⓢ 84x104x11mm, FPM		JC128 		
	JC605 Ⓢ JC475 Ⓢ (x2)	JN433	JJ265 JJ367 07/86 →	PA079 Ⓢ (x8)	NJ285 34x48x8mm, NBR NJ280 Ⓢ 33x47x8mm, NBR NJ284 Ⓢ 84x104x11mm, FPM	NJ658 [208]	JC133 		
	JC126 Ⓢ JC133 Ⓢ	JM086 (50-028281-00)	JH005	PA933 Ⓢ (x8)	NJ045 Ⓢ 48x70x9mm, NBR NJ056 Ⓢ 80x100x13mm, MVQ		JC317 		
							JC475 		
	JB776 JC128	JM044	JH031	PA933 (x12)	NJ045 Ⓢ 48x70x9mm, NBR NJ056 Ⓢ 80x100x13mm, MVQ	HG037 [43]Ⓢ	JC605 		
							JC745 		
							JM086 		
							JN433 		
							JN494 		
							JH005 		



KW/PS

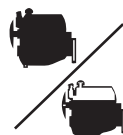

Model				Period	Power (kW/PS)	Engine Code	Configuration	Accessories
Laurel 2.4L				01/85 → 12/87	119	AJ580 (Graphite)	CJ586	
L24E	2393	6	83.00		94/128			
L24S	2393	6	83.00	Injection, SOHC	94/128			
Laurel 2.8L				09/82 →	120	BC380 (Graphite)	DC388	GC388
L28E	2753	6	86.00	SOHC	103-110/ 140-150			
Laurel 2.8L D Diesel				01/85 → 12/89	121	BW620 (MLS)	DW620	GW620
RD28	2825	6	85.00		66/89			
Leopard 2.4L				10/95 → 08/01	122		DV311	GV311
KA24DE	2389	4	89.00	DOHC	98-110/ 133-150			
Lucino 2.0L GTi				11/95 → 01/00	123	BV540 (Fibre)	CY250 DV540	EV540 GV540
SR20DE	1998 1998	4 4	86.00	DOHC	105/143 92-118/ 125-160			
Maxima 2.0L				02/95 → 08/00	124	AG8240 (MLS)	CG8210	EG8230
VQ20DE	1995	6	76.00	Injection, DOHC, V6	103/140	VQ20DE AG8230 (MLS) VQ20DE		
Maxima 2.0L QX				10/97 →	125	AG8240 (MLS)	CG8210	EG8230
Maxima 2.0L V6 24V				03/00 →		→02/00 VQ20DE AG8230 (MLS) →02/00 VQ20DE AG8220 (MLS) 03/00 → AG8210 (MLS) 03/00 →		
VQ20DE	1995	6	76.00	Injection, DOHC, V6	103/140			
Maxima 3.0L				01/95 → 08/00	126	AF5730 (MLS)	CF5700 CF5720	EG8230
VQ30DE	2988	6	93.00	Injection, DOHC, V6	142-147/ 193-200	01/00 → VQ30DE AF5720 (MLS) 01/00 → VQ30DE		
Maxima 3.0L i				10/88 → 06/94	127	BM570 (Graphite) (x2) (30-028270-00) →12/87	DM570 →12/87	
VG30E	2960	6	87.00	Injection, SOHC	95-125/ 129-170			
Maxima 3.0L QX				10/97 →	128	AF5730 (MLS)	CF5700 CF5720	EG8230
VQ30DE	2988	6	93.00	Injection, DOHC, V6	142-147/ 193-200	01/00 → AF5720 (MLS) 01/00 →		
Maxima 3.0L V6 24V				03/00 →	129	AF5730 (MLS)	CF5720 VQ30DE	EG8230
VQ30DE	2988	6	93.00	Injection, DOHC, V6	142-147/ 193-200	VQ30DE AF5720 (MLS) VQ30DE		
Maxima 3.5L QX				08/01 → 02/03	130	AE5910 (MLS)	CG6130	EG8230
VQ35DE	3498	6	95.50	DOHC, V6	206/280	AG6130 (MLS)		

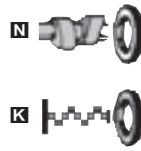
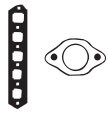

AJ580



BC380



BM570



BV540



BW620



JC128



JC134



JC471



JC472



JC581



JC760



JN570



JN798



JN837

		JC128	JM044	JH031	PA933 (x12)	<input checked="" type="checkbox"/> NJ045 48x70x9mm, NBR <input checked="" type="checkbox"/> NJ056 80x100x13mm, MVQ	HG037 [43]
HBS189 <i>(22-70003B)</i> M12x1.75x105.5mm (x18)	JC128	JM044	JH031	PA933 (x12)	<input checked="" type="checkbox"/> NJ045 48x70x9mm, NBR <input checked="" type="checkbox"/> NJ056 80x100x13mm, MVQ	HG037 [43]	
HBS190 <i>(22-70005B)</i> M12x1.75x112mm (x14)		JN837 <i>(50-028309-00)</i>		PA079 (x12)	<input checked="" type="checkbox"/> NJ285 34x48x8mm, NBR <input checked="" type="checkbox"/> NJ765 40x52x7mm, NBR <input checked="" type="checkbox"/> NJ287 80x100x10mm, MVQ		
		HM5268					
HBS188 <i>(22-70002B)</i> M11x1.50x157mm (x10)	JC134 JC760	JN798		HR767 HR768	<input checked="" type="checkbox"/> NJ106 40x62x10mm, NBR <input checked="" type="checkbox"/> NJ284 84x104x11mm, FPM		
HBS404 <i>(22-70018B)</i>		JM7037					
HBS404 <i>(22-70018B)</i>		JM7037					
HBS404 <i>(22-70018B)</i>		JM7037					
HBS404 <i>(22-70018B)</i>	JC581 (x2) →12/87 JC471 →12/87 JC472 →12/87	JN570 (x2) →12/87	JJ299 →12/87	PA933 (x6) PA079 (x6)	<input checked="" type="checkbox"/> NJ285 (x2) 34x48x8mm, NBR <input checked="" type="checkbox"/> NJ368 33x47x7mm, NBR <input checked="" type="checkbox"/> NJ284 84x104x11mm, FPM	NJ885 [2] 06/87→	
HBS404 <i>(22-70018B)</i>		JM7037					
HBS404 <i>(22-70018B)</i>		JM7037					



KWPS

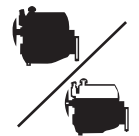

Model		CC	Cyl	Power (kW/PS)	Injection	Year Range	Code	Material	Part Number	Notes
Micra 1.0L						12/82 → 05/89	131	BL760 (Graphite)	DL761	GL760
MA10S		988	4	68.00	Injection, SOHC		37-40/ 50-54	(30-026740-10)	03/87 →	→03/87 GL761 (20-26740-01/0) 03/87 → 12/90
Micra 1.0L						12/82 → 12/89	132	BL760 (Graphite)	DL761	GL760
MA10S		988	4	68.00	Injection, SOHC		37-40/ 50-54	(30-026740-10)	03/87 →	→03/87 GL761 (20-26740-01/0) 03/87 →
Micra 1.0L						01/82 → 12/93	133	BL760 (Graphite)	DL761	GL760
MA10		988	4	68.00	Injection, SOHC		38/52	(30-026740-10)	03/87 →	→03/87 GL761 (20-26740-01/0) 03/87 → 1990
Micra 1.0L 16V						01/03 →	134	AG7880 (MLS) BY900 (Fibre)	CG7880 DY900	FG7880
CG10DE		998	4	71.00	MPI, DOHC		40/54			
Micra 1.0L i 16V						08/92 → 02/03	135	AG7880 (MLS) BY900 (Fibre)	CG7880 DY900	FG7880
CG10DE		998	4	71.00	MPI, DOHC		40/54			
Micra 1.2L						07/86 → 07/92	136	BR160 (Graphite)	DR160	
MA12S		1235	4	71.00	SOHC		40-44/ 54-60	(30-028239-00)	(21-28239-20/0) →12/89 DR161 01/90 →	
Micra 1.2L						01/82 → 12/93	137	BR160 (Graphite)	DR160	GR160
MA12		1235	4	71.00	SOHC			(30-028239-00)	(21-28239-20/0) 11/88 → 12/90 DR161 01/91 →	11/88 → 12/90 GR161 01/91 →
Micra 1.2L 16V						01/03 →	138	AG7880 (MLS)	CG7880	FG7880
CR12DE		1240	4	71.00	DOHC		48-59/ 65-80			
Micra 1.3L i 16V						08/92 → 09/00	139	BY900 (Fibre)	DY900	
CG13DE		1275	4	71.00	MPI, DOHC		55/75			
Micra 1.4L 16V						01/03 →	140			
CR14DE		1386	4	73.00	DOHC		65/88			
Micra 1.4L 16V						08/05 →	141			
CR14DE		1386	4	73.00	DOHC		65/88			
Micra 1.4L i 16V						09/00 → 02/03	142	AG7880 (MLS)	CG7880	FG7880
CGA3DE		1348	4	82.80	DOHC		60/81			
Micra 1.5L D Diesel						02/98 → 02/03	143	BY150 (Fibre), 1.75mm	DY150▲	
TD15 (TUD5)		1527	4	77.00	Indirect Injection		42/57	(30-028755-00)	(21-28757-20/0)	
Micra 1.5L dCi Diesel						01/03 →	144	AE5200 (MLS) AG9490 (MLS)	CE5200▲	EE5200
K9K 704		1461	4	76.00	Direct Injection, SOHC		48/65	(30-029015-00)	(21-29015-20/0)	
K9K 722		1461	4	76.00	Direct Injection, SOHC		60/82	→05/04 (30-029497-00) 05/04 →		

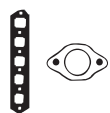

AE5200



BL760



BR160



BY150



BY900



JC459



JC460



JC875



JC876



JN564

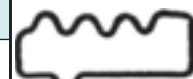

JN840



JP041



JJ587

HBS110® [22-70004B] M10x1.50x146mm (x10)	JC460■ JC459■	JN564 (50-028280-00)	HC443■	PA079 (x8)	■ NJ363 38x54x7mm, NBR ■ NJ363■ 38x54x7mm, NBR ■ NJ364■ 75x94x10mm, MVQ	NJ082 [2]■ NJ083 [2]■ NJ553 [2]■
HBS110® [22-70004B] M10x1.50x146mm (x10)	JC460■ JC459■	JN564 (50-028280-00)	HC443■	PA079 (x8)	■ NJ363 38x54x7mm, NBR ■ NJ363■ 38x54x7mm, NBR ■ NJ364■ 75x94x10mm, MVQ	NJ082 [2]■ NJ083 [2]■ NJ553 [2]■
HBS110® [22-70004B] M10x1.50x146mm (x10)	JC460■ JC459■	JN564 (50-028280-00)	HC443■	PA079 (x8)	■ NJ363 38x54x7mm, NBR ■ NJ363■ 38x54x7mm, NBR ■ NJ364■ 75x94x10mm, MVQ	NJ082 [2]■ NJ083 [2]■ NJ553 [2]■
HBS110® [22-70004B] M10x1.50x146mm (x10)	JC875■ JD5841 ■ (FPM) JC876■ (x2)	JM5298 (ACM) 02/03 → CGA3DE	HC5010■			
HBS110® [22-70004B] M10x1.50x146mm (x10)	JC875■ JD5841 ■ (FPM) JC876■ (x2)	JM5281	HC5010■			
HBS110® [22-70004B] M10x1.50x146mm (x10)	JC460■ JC459■	JN840 (50-026774-00)		PA079■ (x8)	■ NJ363 38x54x7mm, NBR ■ NJ363■ 38x54x7mm, NBR ■ NJ364■ 75x94x10mm, MVQ	
HBS110® [22-70004B] M10x1.50x146mm (x10)	JC460■ JC459■	JN840 (50-026774-00)		PA079■ (x8)	■ NJ363 38x54x7mm, NBR ■ NJ363■ 38x54x7mm, NBR ■ NJ364■ 75x94x10mm, MVQ	
	JD5841 ■ (FPM)	JM5298 (ACM) 02/03 → CGA3DE				
HBS110® [22-70004B] M10x1.50x146mm (x10)	JC875■ JC876■ (x2)	JM5281	HC5010■			
	JD5841 ■ (FPM)	JM5298 (ACM)				
	JD5841 ■ (FPM)					
HBS110® [22-70004B] M10x1.50x146mm (x10)	JD5841 ■ (FPM)					
HBS113® [22-15015B] M11x1.50x185mm (x10)		JP041 (50-028757-00)	JJ587	HR642■	■ NF817 36x50x7mm, FPM (50-319112-00) ■ NF870■ 42x66x6mm, FPM/ACM (50-319113-00) ■ NF857■ 85x105x9mm, FPM/ACM (50-319478-00)	HL5011 [245]■
HBS299® [22-29019B] M11x1.50x125.0mm (x10)	JD5402■ (31-030008-00) ● KK5643 (31-030009-00)	JM7054 (NBR)	JH5109 (NBR)	HR817■ 24-30614-78/0	■ NA5215 28x42x5mm, FPM ■ NA5255■ 35x47x7mm	HL5026 [245]■



kWPS

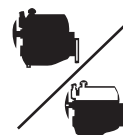

Model		Year Range		Power (kW)	Engine Details	Code	Accessories
Micra 1.5L dCi Diesel		01/03 →		145	AE5200 (MLS) (30-029015-00) →05/04 AG9490 (MLS) (30-029497-00) 05/04 →	CE5200▲ (21-29015-20/0)	EE5200
	1461	4		50/68			
	1461	4		63/86			
Murano 3.5L 4x4		11/07 →		146	AE5910 (MLS) ☒	CG5882	EG8230
Murano 3.5L		11/07 →			AG6130 (MLS) ☒		
	3498	6		195/265			
VQ35DE	3498	6	95.50	DOHC, V6	206/280		
Murano 3.5L 4x4		03/05 →		147	AE5910 (MLS) ☒	CG6130	EG8230
VQ35DE	3498	6	95.50	DOHC, V6	206/280	AG6130 (MLS) ☒	
Note 1.4L		03/06 →		148			
CR14DE	1386	4	73.00	DOHC	65/88		
Note 1.5L dCi Diesel		03/06 →		149	AG9490 (MLS) (30-029497-00)	CE5200▲ (21-29015-20/0)	EE5200
	1461	4	76.00	63/86			
K9K 700				48-50/ 65-68			
Pathfinder 2.4L		05/99 →12/04		150	BV310 (Graphite)	DV311	GV311
	2389	4		105/143			
KA24DE	2389	4	89.00	DOHC	98-110/ 133- 150		
Pathfinder 2.4L		01/83 →		151	BL260 (Graphite) BR660 (Graphite) (30-028261-00) 1984 →	DR662■ (21-28261-21/0) 1984 →	GR662 1984 →
Z24S	2388	4	89.00	SOHC	74/100		
Pathfinder 3.0L		01/86 →		152	BM570 (Graphite) (x2) (30-028270-00)	DM577	GM572 GM577 01/88 →
VG30I	2960	6	87.00	Injection, SOHC	95/129		
Pathfinder 3.3L		05/99 →12/04		153	AF5690 (Graphite) (x2)	CF5690	FF5690
Pathfinder 3.3L V6 4WD		09/97 →12/04					
VG33E	3275	6	91.50	SOHC, V6	110- 125/ 150- 170		
Pathfinder 3.5L V6 4WD		11/00 →12/04		154	AE5890 ☒ AE5880 ☒	CG5882	EG8230
VQ35	3498	6	95.50	DOHC, V6	162/220		
Patrol 2.8L		05/86 →06/90		155	BC380 (Graphite)	DC388■	GC388
L28	2753	6	86.00	Injection, SOHC	88-89/ 120- 121		
Patrol 2.8L		07/80 →08/88		156	BC380 (Graphite) 09/82 →	DC380■ DC388■ 09/82 →	GC383 GC388 09/82 →
L28	2753	6	86.00	Injection, SOHC	88-89/ 120- 121		
Patrol 2.8L		07/80 →08/88		157	BC380 (Graphite) 09/82 →	DC380■ DC388■ 09/82 →	GC383 GC388 09/82 →
L28	2753	6	86.00	Injection, SOHC	88-89/ 120- 121		
Patrol 2.8L Diesel		01/83 →		158	BW620 (MLS)	DW620	GW620
RD28	2825	6	85.00		66/89		
Patrol 2.8L		01/87 →12/90		159	BC380 (Graphite)		
L28S	2753	6	86.00	SOHC			

HBS299 ⊕ (22-29019B) M11x1.50x125.0mm (x10)	JD5402 ⊖ (31-030008-00) ⊕ KK5643 (31-030009-00)								AE5200	
HBS404 (22-70018B)		JM5316 ⊖ JM5317 ⊖							BC380	
HBS404 (22-70018B)		JM5316 ⊖ JM5317 ⊖							BL260	
	JD5841 ■ (FPM)								BM570	
HBS299 ⊕ (22-29019B) M11x1.50x125.0mm (x10)	JD5402 ⊖ (31-030008-00) ⊕ KK5643 (31-030009-00)	JM7054 (NBR)	JH5109 (NBR)	HR817 ⊖ 24-30614-78/0	NA5215 28x42x5mm, FPM NA5255 ⊖ 35x47x7mm		HL5026 [245]⊖		BR660	
	JC997 ■	JN880 HM5268 ⊖		PA079 (x16)	NK106 ⊖ 46x58x7mm, ACM				BV310	
	JC580 ■ →12/84 JC126 ■ 01/85→ JC133 ⊖ (x2)	JM086 (50-028281-00)	JH005	PA933 ⊖ (x8)	NJ045 ⊖ 48x70x9mm, NBR NJ056 ⊖ 80x100x13mm, MVQ				BW620	
	JC581 ■ (x2) JC472 ⊖ (x2)	JN570 (x2)	JJ299 →12/87	PA933 ⊖ PA079 ■	NJ285 (x2) 34x48x8mm, NBR NJ368 ⊖ 33x47x7mm, NBR NJ284 ⊖ 84x104x11mm, FPM				JC126	
HBS443 [209] (22-70019B)									JC128	
HBS404 (22-70018B)		JM5316 ⊖ VQ3SDE JM5317 ⊖ VQ3SDE							JC128	
HBS189 ⊕ (22-70003B) M12x1.75x105.5mm (x18)	JC128	JM044	JH031	PA933 ⊖ (x12)	NJ045 ⊖ 48x70x9mm, NBR NJ056 ⊖ 80x100x13mm, MVQ		HG037 [43]⊖		JC133	
HBS189 ⊕ (22-70003B) M12x1.75x105.5mm (x18)	JB776 JC128 09/82→	JP044 (50-028763-00) 09/82→	JH031 09/82→	PA933 (x12) 09/82→	NJ045 ⊖ 48x70x9mm, NBR NJ056 ⊖ 80x100x13mm, MVQ 09/82→		HG037 [43]⊖ 09/82→		JC472	
HBS189 ⊕ (22-70003B) M12x1.75x105.5mm (x18)	JB776 JC128 09/82→	JM044 09/82→	JH031 09/82→	PA933 ⊖ (x12) 09/82→	NJ045 ⊖ 48x70x9mm, NBR NJ056 ⊖ 80x100x13mm, MVQ 09/82→		HG037 [43]⊖ 09/82→ Not for Patrol UK		JC580	
HBS190 ⊕ (22-70005B) M12x1.75x112mm (x14)		JN837 (50-028309-00)		PA079 ■ (x12)	NJ285 34x48x8mm, NBR NJ765 ⊖ 40x52x7mm, NBR NJ287 ⊖ 80x100x10mm, MVQ				JC581	
	JC128	JM044	JH031		NJ045 ⊖ 48x70x9mm, NBR NJ056 ⊖ 80x100x13mm, MVQ		HG037 [43]⊖		JM086	



KW/PS

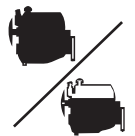

Patrol 2.8L TD Diesel		05/86 → 06/97		160	BV250 (MLS), 1.50mm (30-028267-00)	DV250 (21-28267-20/0)	GV250 (20-28267-00/0)
RD28T	2826	6	85.00	SOHC	85/116		
Patrol 2.8L TD Diesel		06/97 → 05/00		161	BV250 (MLS), 1.50mm (30-028267-00)	DV250 (21-28267-20/0)	
RD28Ti	2826	6	85.00	SOHC	95/129		
Patrol 3.0L DTi Diesel		05/00 →		162	AF5740 (MLS), 0.65mm, 1 Notch ZD30DDTi	CF5740▲	FF5740▲
Patrol GR 3.0L D Mk II Diesel		05/00 → 09/04			AF5750 (MLS), 0.7mm, 2 Notches ZD30DDTi		
ZD30DDTi	2953	4	96.00	Direct Injection, DOHC	116- 125/ 158- 170		
Patrol 3.2L D Diesel		08/88 → 06/90		163	BJ360 (Graphite) (30-026739-10)	DJ363■	
	3224	6			81/110		
Patrol 3.3L D Diesel		11/79 → 08/88		164	BJ360 (Graphite) (30-026739-10)	DJ360■ → 06/82	GJ360 → 06/82
SD33	3246	6	83.00		BS830 (Graphite)	DJ363■ 07/82 →	GJ363 07/82 →
Patrol 4.2L		11/88 → 06/97		165	AF5600 (Fibre) 01/92 →	CF5600	FF5600
Patrol GR 4.2L Allrad Mk I		02/88 → 12/95					
TB42E	4169	6	96.00		121- 129/ 165- 175		
Pick Up 1.8L		01/83 → 03/86		166	AJ490 (Graphite)		FJ495
L18	1770	4	85.00		59-65/ 80-88		
Pick Up 2.0L		09/85 → 07/88		167	BG720 (Graphite)	DG724 (21-28250-20/0) → 09/86	GG724 → 09/86
Z20	1952	4	85.00	SOHC	64/87	DG725■ 10/86 →	GG725 10/86 →
Pick Up 2.0L		09/88 → 08/91		168	BG720 (Graphite)	DG725■	GG725
Z20	1952	4	85.00	SOHC	64/87		
Pick Up 2.2L 4WD		04/83 → 03/86		169	BJ350 (Fibre)	DJ353■	
Z22	2187	4	87.00	SOHC	71/96		
Pick Up 2.3L D Diesel		04/83 → 03/86		170	BL770 (Graphite) (30-028366-00) → 12/83	DL770 → 12/83	GL770 → 12/83
SD23	2289	4	89.00		BM580 (Steel Elastomer) (30-028257-00) 01/84 →	DM580■ (21-28257-20/0) 01/84 → 07/85	GM580 01/84 → 01/85
						DM581 (21-28257-21/0) 08/85 →	GM581 08/85 →
Pick Up 2.3L D Diesel		09/85 → 08/88		171	BM580 (Steel Elastomer) (30-028257-00)	DM581 (21-28257-21/0)	GM581
SD23	2289	4	89.00		50-51/ 68-69	DS760■	
Pick Up 2.4L		11/01 → 04/05		172	BV310 (Graphite)	DV311	GV311
Pick Up 2.4L i 4WD		03/02 →					
KA24DE	2389	4	89.00	DOHC	98-110/ 133- 150		
Pick Up 2.4L		01/83 →		173	BL260 (Graphite) BR660 (Graphite) (30-028261-00) 1984 →	DR662■ (21-28261-21/0) 1984 →	GR662 1984 →
Z24S	2388	4	89.00	SOHC	74/100		

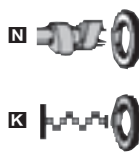
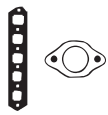

HBS190 ® (22-70005B) M12x1.75x112mm (x14)		JN837 (50-028309-00)		PA079 (x12)	NJ285 34x48x8mm, NBR NJ765 40x52x7mm, NBR NJ287 80x100x10mm, MVQ	
HBS190 ® (22-70005B) M12x1.75x112mm (x14)		JN837 (50-028309-00)		PA079 (x12)		
		JM5318 ZD30DDTI				
			JJ151	KJ452 (x12)	LV501 (x2)	
	JC188 (x2) →12/80	JN597 (50-028315-00) 07/82→	JJ151	KJ452 (x12) →06/82 PA884 (x12) 07/82→	NJ369 58x80x12mm, MVQ LV501 (x2)	
HBS433 ® (22-70016B) M12x1.50x113.0mm (x26)						
	JC126 (x2) JC133 (x2)	JM086 (x2) (50-028281-00)	JH005	PA933 (x8)	NJ045 48x70x9mm, NBR NJ056 80x100x13mm, MVQ	
	JC126 (x2) JC133 (x2)	JM086 (50-028281-00)	JH005	PA933 (x8)	NJ045 48x70x9mm, NBR NJ056 80x100x13mm, MVQ	
	JC126 (x2) JC133 (x2)	JM086 (50-028281-00)	JH005		NJ045 48x70x9mm, NBR NJ056 80x100x13mm, MVQ	
	JC473 →07/85 JC668 08/85→	JM055 →12/83 JN416 (50-028298-00) 01/84→	JJ281	PA378 (x8)	NJ369 58x80x12mm, MVQ NJ287 80x100x10mm, MVQ	
	JC668	JN416 (50-028298-00)	JJ281	PA378 (x8)	NJ369 58x80x12mm, MVQ NJ287 80x100x10mm, MVQ	
	JC997	JN880 HM5268		PA079 (x16)	NK106 46x58x7mm, ACM	
	JC580 (x2) →1983 JC126 (x2) 1984→ JC133 (x2)	JM086 (50-028281-00)	JH005	PA933 (x8)	NJ045 48x70x9mm, NBR NJ056 80x100x13mm, MVQ	

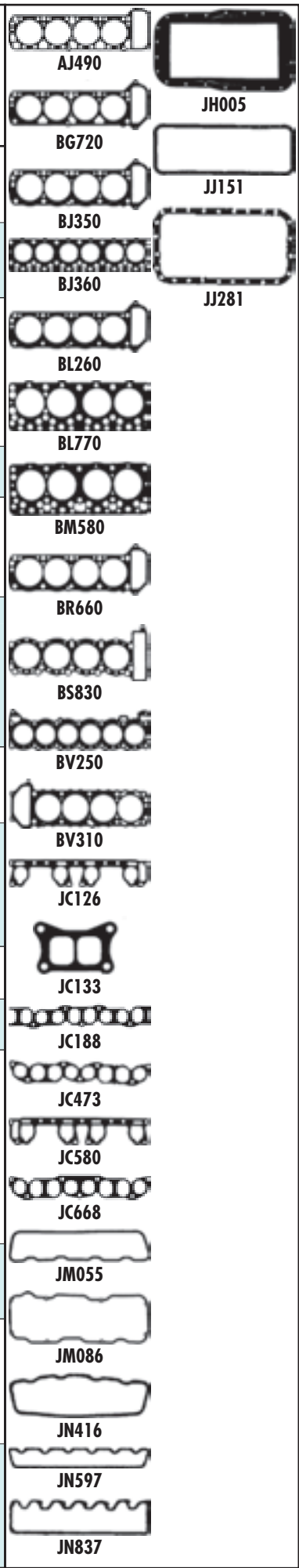







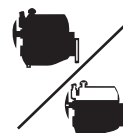



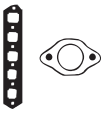

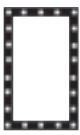

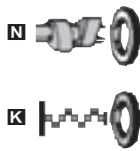

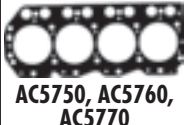
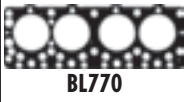
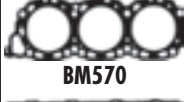





NISSAN

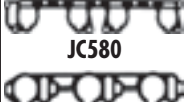

KW/PS

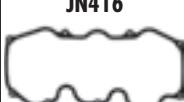

Pick Up 2.4L i 02/98 → 174 Pick Up 2.4L i 12V 04/92 → 02/98 Pick Up 2.4L i 4WD 02/98 →					BS770 (Graphite) (30-028258-00)	DS771 ■ (21-28258-21/0)	GS771
KA24E	2389	4	89.00	Injection, SOHC	85-98/ 116- 133		
Pick Up 2.4L i 12V 4WD 04/92 → 02/98 175					BS770 (Graphite) (30-028258-00)	DS771 ■ (21-28258-21/0)	GS770
KA24E	2389	4	89.00	Injection, SOHC	85-98/ 116- 133		
Pick Up 2.4L i 4WD 03/86 → 04/92 176					BR660 (Graphite) (30-028261-00)	DR660 ■	GR661
Z24i	2389	4	89.00	SOHC	74-77/ 101- 105		
Pick Up 2.5L D Diesel 09/87 → 02/98 177 Pick Up 2.5L D 4WD Diesel 08/87 → 02/98					BW540 (MLS), 1.40mm	DW540 ■ (21-28889-20/0)	GW540
TD25	2494	4	92.90	Indirect Injection	55-61/ 75-83		
Pick Up 2.5L D 4WD Diesel 02/98 → 178 Pick Up 2.5L TD 4WD Diesel 05/98 →					AC5750 (MLS), 1.20mm, 1 Notch (30-029544-00) AC5760 (MLS), 1.25mm, 2 Notches (30-029545-00) AC5770 (MLS), 1.30mm, 3 Notches (30-029546-00)	CC5750 ▲	
TD25	2494	4	92.90	Indirect Injection	55-61/ 75-83		
TD25Ti	2494	4	92.90	Indirect Injection	76/103		
Pick Up 2.5L D 4WD Diesel 09/85 → 08/91 179					BL770 (Graphite) (30-028366-00) BM580 (Steel Elastomer) (30-028257-00)	DM581 (21-28257-21/0)	GM581
SD25	2488	4	89.00		53-55/ 72-75		
Pick Up 2.5L D 4WD Diesel 04/83 → 03/86 180					BL770 (Graphite) (30-028366-00) BM580 (Steel Elastomer) (30-028257-00)	DM580 ■ (21-28257-20/0) → 07/85 DM581 (21-28257-21/0) 08/85 →	GM580 → 07/85 GM581 08/85 →
SD25	2488	4	89.00		53-55/ 72-75		
Pick Up 2.5L Di Diesel 03/02 → 181					AD5260 (MLS), 0.8mm, 1 Hole	CD5260 ▲	
YD25DDTi	2488	4	89.00	Direct Injection, DOHC	98-110/ 133- 150		
Pick Up 2.7L D 4WD Diesel 08/87 → 02/98 182					BS200 (MLS), 1.40mm (30-028265-00)	DS200 ■	GS200
TD27	2663	4	96.00	Indirect Injection	58-73/ 79-99		
Pick Up 2.7L TD Diesel 02/98 → 183						CC5750 ▲	
TD27	2663	4	96.00	Indirect Injection	58-73/ 79-99		
Pick Up 3.0L i V6 4WD 09/90 → 02/98 184					BM570 (Graphite) (x2) (30-028270-00)		GM572
VG30E	2960	6	87.00	Injection, SOHC	95-125/ 129- 170		
Pick Up 3.0L TD Diesel 11/01 → 185 Pick Up 3.0L TD 4WD Diesel 11/01 →							FF5740 ▲
ZD30	2953	4	96.00	Direct Injection	110/150		
Pick Up 3.3L 4WD 01/03 → 186							FF5690
VG33E	3275	6	91.50	SOHC, V6	110- 125/ 150- 170		

								
HBS432 ⊗ (22-70015B) M10x1.50x110.0mm (x10)	JC901 ■ JC900 ■	JN743 (50-028304-00)		PA933 ■ (x4) PA079 ■ (x8)	NK106 ■ 46x58x7mm, ACM			 JN724  JN739  JN743  JJ281
HBS432 ⊗ (22-70015B) M10x1.50x110.0mm (x10)	JC901 ■ JC900 ■	JN739 (50-028301-00)		PA933 ■ (x4) PA079 ■ (x8)	NK106 ■ 46x58x7mm, ACM			 BR660  BS200  BS770  BW540
	JC580 ■ JC133 ■ (x2) ⊙JE747	JN702		PA933 ■ (x8)	NJ045 ■ 48x70x9mm, NBR NJ056 ■ 80x100x13mm, MVQ			 JC133  JC472
HBS194 ⊗ (22-70010B) M12x1.50x113mm (x18)	JC805 ■ JC806 ■ (x4)	JN724 (50-028308-00)		PA378 (x8)	NJ831 ■ 58x80x10mm, NBR NJ829 ■ 86x100x10mm, MVQ			 JC473  JC580  JC581  JC668
	JC805 ■ JC806 ■ (x4)	JN724 (50-028308-00)		PA378 (x8)	NJ831 ■ 58x80x10mm, NBR NJ829 ■ 86x100x10mm, MVQ			 JC806  JC900
	JC668	JN416 (50-028298-00)	JJ281	PA378 (x8)	NJ369 ■ 58x80x12mm, MVQ NJ287 ■ 80x100x10mm, MVQ			 JC901  JN416
	JC473 →07/85 JC668 08/85→	JN416 (50-028298-00)	JJ281	PA378 (x8)	NJ369 ■ 58x80x12mm, MVQ NJ287 ■ 80x100x10mm, MVQ			 JN570  JN702
HBS374 ⊗ (22-70012B) M11x1.25x109mm (x10)		JM5137		PA5020 (x16) (50-319496-00)	NJ369 ■ 58x80x12mm, MVQ NA5090 ■ 76x94x8.5mm, FPM (50-319499-00)			
HBS194 ⊗ (22-70010B) M12x1.50x113mm (x18)	JC805 ■ JC806 ■ (x4)	JN724 (50-028308-00)		PA378 (x8)	NJ831 ■ 58x80x10mm, NBR NJ829 ■ 86x100x10mm, MVQ			
HBS404 (22-70018B)	JC581 ■ (x2) JC472 ■ (x2)	JN570 (x2)	HC460 ■	PA933 ■ (x6) PA079 ■ (x6)	NJ285 (x2) 34x48x8mm, NBR NJ368 ■ 33x47x7mm, NBR NJ284 ■ 84x104x11mm, FPM			



KW/PS

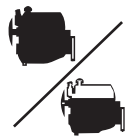

Prairie 1.5L S		01/84 → 12/87		187	BK440 (Graphite) (30-026185-10)	DK445	GK446
E15S	1488	4	76.00	SOHC	52-55/ 71-75		
Prairie 1.8L SGL		07/83 → 10/87		188	BK480 (Fibre) (30-024578-10) BM590 (Graphite) (30-028247-00)	DM598 Europe	
CA18S	1809	4	83.00	Injection, SOHC			
Prairie 2.0L		10/84 →		189	BM760 (Graphite) (30-026733-10)	DM762	
CA20E	1974	4	84.50	Injection, SOHC	72-85/ 98-116		
Prairie 2.0L 4x4		06/86 → 09/88		190	BM760 (Graphite) (30-026733-10)	DM765	GM765
CA20S	1974	4	84.50	Injection, SOHC	66-78/ 90-106		
Prairie Pro 2.4L i		04/92 → 07/94		191	BS770 (Graphite) (30-028258-00)	DS771 ■ (21-28258-21/0)	GS771
KA24E	2389	4	89.00	Injection, SOHC	85-98/ 116- 133		
Primastar 1.9L dCi 100 Diesel		03/01 →		192	AC5061 (MLS), 1.32mm (30-029473-10)	CC5060 ▲ (21-29483-20/0)	EC5060 (22-29474-00/0)
Primastar 1.9L dCi 80 Diesel		03/01 →			AC5070 (Fibre), 1.35mm, 2 Notches (30-029474-00) → +0.653mm AC5080 (Fibre), 1.45mm, 1 Notch (30-029475-00) → +0.653 → +0.786mm		
F9Q 762	1870	4	80.00	Direct Injection, SOHC	60/82		
F9Q 760	1870	4	80.00	Direct Injection, SOHC	74/101		
Primastar 2.0L dCi 120 Diesel		09/06 →		193	AD5990 (MLS) (30-029781-00)	CD5991	ED5991
	1995	4			84/114		
Primastar 2.0L		03/01 →		194	AD5990 (MLS) (30-029781-00)	CD5991	ED5991
F4R 720/F4R 722	1998	4	82.70	Injection, DOHC	88/120		
Primastar 1.9 dCi 140 Diesel		09/03 →		195	AE5210 (MLS), 1.24mm (30-029250-00)	CE5210	EE5220 (22-29037-00/0)
G9U 730	2463	4	89.00	Direct Injection	99/135		
Primera 1.6L		06/93 → 01/96		196	BP960 (Graphite) (30-028243-00)	DP960 (21-28243-20/0)	GP960 (20-28243-00/0)
GA16DE	1597	4	76.00	MPI, DOHC	66-75/ 90-102		
Primera 1.6L Visia		01/02 →		197	AB5630 (MLS)	CB5630	
Primera 1.6L		01/02 →					
Primera 1.6L 16V		04/98 → 07/02					
QG16DE	1597	4	76.00	DOHC	78-80/ 106- 109		
Primera 1.6L		06/90 → 01/96		198	BP970 (Graphite) BV440 (Fibre) 01/94 →	DP970 (21-28244-20/0) DV440 01/94 →	GP970 (20-28244-00/0) GV440 01/94 →
Primera 1.6L i		07/90 → 03/98					
GA16DS	1597	4	76.00	DOHC			
Primera 1.6L		06/90 → 01/96		199	BP970 (Graphite) BV440 (Fibre) 01/94 →	DP970 (21-28244-20/0) DV440 01/94 →	GP970 (20-28244-00/0) GV440 01/94 →
GA16DS	1597	4	76.00	DOHC			
Primera 1.6L 16V		09/96 → 07/02		200	BP960 (Graphite) (30-028243-00) BV440 (Fibre)	DV440	GV440
GA16DE	1597	4	76.00	MPI, DOHC	66-75/ 90-102		







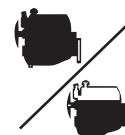



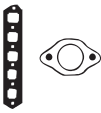

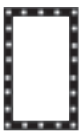

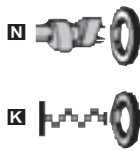





HBS409 (22-70017B) 01/86 →	HA371 HA372 JF031	JN665	HC442	PA203 (x8)	NJ288 40x55x9mm, NBR NJ286 36x49x7mm, NBR NJ287 80x100x10mm, MVQ	NJ419 [2] NJ552 [2] NJ679 [2]	AC5070, AC5080 JN624	AE5210 JN665
	JC317 JC475 (x2)	JN433	JJ265	PA079 (x8)	NJ285 34x48x8mm, NBR NJ280 33x47x8mm, NBR NJ284 84x104x11mm, FPM	NJ419 [2] NJ552 [2] 07/86 → NJ639 [2] 07/86 →	BK440 JN739	BK480 JN743
	JC605 JD029 →01/87 JC475 (x2)	JN433	JJ265 JJ367 01/86 → JJ368 01/86 →	PA079 (x8)	NJ285 34x48x8mm, NBR NJ280 33x47x8mm, NBR NJ284 84x104x11mm, FPM		BM590 JN829	BM760 JN838
HBS432 (22-70015B) M10x1.50x110.0mm (x10)	JC901 JC900	JN739 (50-028301-00) JN743 (50-028304-00)		PA933 (x4) PA079 (x8)	NK106 46x58x7mm, ACM		BP960 JJ265	
HBS120 (22-51008B) M12x1.50x118mm (x10)	JD5189	JM5086	JH5041 KG5012 16x23x1.5mm	HR646 24-30670-60/0	NF846 25x42x7mm, FPM/ACM (50-319516-00) NA5036 42x54x6mm, FPM (50-319473-00) NF850 85x105x8mm, FPM (50-319183-00)	HL5017 [245]	BP970 JJ367	BS770
HBS310 (22-51108B) M12x1.50x117mm (x10)		HR397 [57] 34-000410-00					BV440	JC317
HBS310 (22-51108B) M12x1.50x117mm (x10)		HR397 [57] 34-000410-00			NA5257 28x47x5.5mm		JC475	JC605
HBS373 (22-51110B) M12x1.50x131mm (x10)							JC761	JC900
HBS187 (22-70001B) M10x1.50x97mm (x10)			JH5100				JC901	JD001
HBS422 (22-70020B) M10x1.50x92mm (x10)							JD091	JD110
HBS187 (22-70001B) M10x1.50x97mm (x10)	JD093 JD091 (x2)	JN838 (50-028284-00)	JH5100	PB681 (x16)	NJ207 29x49x7.5mm, ACM NJ765 40x52x7mm, NBR NJ284 84x104x11mm, FPM	NK212 [2]	JN433	
HBS187 (22-70001B) M10x1.50x97mm (x10)	JD093 JD091	JN838 (50-028284-00)	JH5100	PB681 (x16)	NJ207 29x49x7.5mm, ACM NJ765 40x52x7mm, NBR NJ284 84x104x11mm, FPM	NK212 [2]		
HBS187 (22-70001B) M10x1.50x97mm (x10)	JD001 JC761 JD110 JD091 (x2)	JN829 (50-028283-00)			NJ207 29x49x7.5mm, ACM NJ222 40x52x7mm, FPM NJ284 84x104x11mm, FPM			



KW/PS



Primer 1.6L i		03/94 → 03/98		201	BP960 (Graphite) (30-028243-00) BV440 (Fibre)	DV440	GV440
GAI6DE	1597	4	76.00	MPI, DOHC	66-75/ 90-102		
Primer 1.8L		03/02 →		202	AB5690 (MLS)	CB5611	FB5610
Primer 1.6V		08/99 → 07/02					
QG18DE	1769	4	80.00	Injection, DOHC	84-93/ 114- 126		
Primer 1.9L dCi Diesel		04/03 →		203	AC5061 (MLS), 1.32mm (30-029473-10) AC5070 (Fibre), 1.35mm, 2 Notches (30-029474-00) → +0.653mm AC5080 (Fibre), 1.45mm, 1 Notch (30-029475-00) → +0.653 → +0.786mm	CC5060▲ (21-29483-20/0)	EC5060 (22-29474-00/0)
	1870	4			88/120		
Primer 2.0L		03/02 →		204	AF5540 (MLS)	CF5541	FF5541
QR20DE	1998	4	89.00	DOHC	103- 110/ 140- 150		
Primer 2.0L		06/90 → 01/98		205	BV540 (Fibre)	DV541	
Primer GT		03/91 → 04/93					
SR20DE	1998	4	86.00	DOHC	92-118/ 125- 160		
Primer 2.0L 16V		09/96 → 07/02		206	BV540 (Fibre)	DV542	EV540
Primer 2.0L i		01/95 → 06/96					
SR20DE	1998	4	86.00	DOHC	85/115		
SR20DE	1998	4	86.00	DOHC	92-118/ 125- 160		
Primer 2.0L 16V		06/90 → 01/96		207	BV540 (Fibre)	DV541	EV540 GV541
SR20DI (SPI)	1998	4	86.00	SPI, DOHC	85/115		
Primer 2.0L 16V 4x4		04/91 → 06/96		208	BV540 (Fibre)	DV541	EV540 GV541
Primer 2.0L i		07/90 → 03/98					
SR20DI (SPI)	1998	4	86.00	SPI, DOHC	85/115		
Primer 2.0L D Diesel		07/90 → 01/96		209	BW420 (MLS) (30-028861-00)	DW420	GW420 GW421▲
CD20	1974	4	84.50		55/75		
Primer 2.0L GT		06/90 → 01/96		210	BV540 (Fibre)	CY250■ DV540■	EV540 GV540
SR20DE	1998	4	86.00	DOHC	92-118/ 125- 160		
Primer 2.0L i		01/95 → 06/96		211	BV540 (Fibre)	DV541	EV540 GV540
SR20DE	1998	4	86.00	DOHC	92-118/ 125- 160		
Primer 2.0L TD Diesel		09/96 → 07/02		212	AD5280 (MLS), 1.15mm, 1 Hole AD5281 (MLS), 1.25mm, 3 Notches CD20T	CD5280▲	
CD20T	1974	4	84.50	SOHC	66/90		







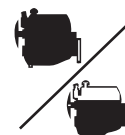



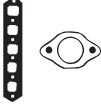

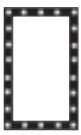

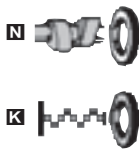



































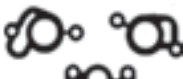











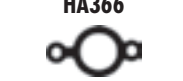































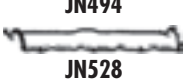







								 AC5070, AC5080
HBS187 ® (22-70001B) M10x1.50x97mm (x10)	JD001 ■ JC761 JD110 JD091 ■ (x2)	JN829 (50-028283-00)	JH5100		<input checked="" type="checkbox"/> NJ207 29x49x7.5mm, ACM →12/94 <input checked="" type="checkbox"/> NJ765 ■ 40x52x7mm, NBR →12/94 <input checked="" type="checkbox"/> NJ284 ■ 84x104x11mm, FPM <input checked="" type="checkbox"/> NJ222 ■ 40x52x7mm, FPM 01/95→			 BP960  BV440  BV540  BW420
HBS422 (22-70020B) M10x1.50x92mm (x10)								 JC760  JC761  JD001  JD091
HBS120 ® (22-51008B) M12x1.50x118mm (x10)	JD5189	JM5086	JH5041 ● KG5012 16x23x1.5mm	HR646 ■ 24-30670-60/0	<input checked="" type="checkbox"/> NF846 25x42x7mm, FPM/ACM (50-319516-00) <input checked="" type="checkbox"/> NA5036 ■ 42x54x6mm, FPM (50-319473-00) <input checked="" type="checkbox"/> NF850 ■ 85x105x8mm, FPM (50-319183-00)		HL5017 [245]■	 JD110  JD134  JD135  JN798  JN829
HBS188 ® (22-70002B) M11x1.50x157mm (x10)								
HBS188 ® (22-70002B) M11x1.50x157mm (x10)								
HBS188 ® (22-70002B) M11x1.50x157mm (x10)								
HBS188 ® (22-70002B) M11x1.50x157mm (x10)	JD135 ■ JC760 ■	JN798		HR767 ■ ■	<input checked="" type="checkbox"/> NJ106 ■ 40x62x10mm, NBR <input checked="" type="checkbox"/> NJ284 ■ 84x104x11mm, FPM			
HBS188 ® (22-70002B) M11x1.50x157mm (x10)	JD135 ■ JC760 ■	JN798		HR767 ■	<input checked="" type="checkbox"/> NJ106 ■ 40x62x10mm, NBR <input checked="" type="checkbox"/> NJ284 ■ 84x104x11mm, FPM			
HBS111 ® (22-70006B) M11x1.50x119mm (x10)	JD5761	JM5138	HC5011 ■					
HBS188 ® (22-70002B) M11x1.50x157mm (x10)	JD134 ■ JC760 ■	JN798		HR767 ■ ■	<input checked="" type="checkbox"/> NJ106 ■ 40x62x10mm, NBR <input checked="" type="checkbox"/> NJ284 ■ 84x104x11mm, FPM			
HBS188 ® (22-70002B) M11x1.50x157mm (x10)								
HBS111 ® (22-70006B) M11x1.50x119mm (x10) →12/98	JD5761	JM5138	HC5011 ■					



KW/PS

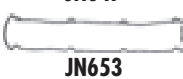

Primera 2.2L dCi Diesel 04/03 → 213						AD5260 (MLS), 0.8mm, 1 Hole	CD5260▲	
Primera 2.2L Di Diesel 03/02 →								
YD22DDT	2184	4	86.00	Direct Injection, DOHC	81-102/ 110- 139			
Primera 2.5L 01/02 → 214						AF5540 (MLS)	CF5540	
QR25DE	2488	4	89.00	DOHC	121/165			
Pulsar 1.3L 01/81 → 12/86 215						BK440 (Graphite) (30-026185-10) → 12/82	DK441 → 12/82	GK441 → 12/82
E13	1270	4	76.00	SOHC	44/60			
Pulsar 1.5L Turbo 01/83 → 12/86 216						BK440 (Graphite) (30-026185-10)		
E15T	1488	4	76.00	Injection, SOHC, Turbo	77/105			
Pulsar 1.6L 01/82 → 12/89 217						BK440 (Graphite) (30-026185-10)	DK440 (21-26185-25/0) → 12/84 DK449 (21-26737-25/0) 01/85 → 12/86 DK446 (21-26737-26/0) 01/87 →	GK440 → 12/84 GK447 01/87 →
E16	1597	4	76.00	SOHC				
Pulsar 1.6L 12V 07/88 → 08/90 218						BS610 (Graphite) (30-028240-00) BV990 (Graphite)	DS612	GS612
GA16	1597	4	76.00	SOHC				
Pulsar 1.6L 16V 01/87 → 12/90 219						BR240 (Graphite)	DR240	GR240
CA16DE	1598	4	78.00	DOHC				
Pulsar 1.7L Diesel 10/82 → 12/86 220						BP580 (Graphite), 1,20mm (30-026734-10)	DP581	GP581
CD17	1680	4	80.00	SOHC				
Qashqai 1.5L dCi Diesel 02/07 → 221						AE5200 (MLS) (30-029015-00)	CE5200▲ (21-29015-20/0)	
	1461	4			78/106			
Qashqai 2.0L dCi Diesel 02/07 → 222								
M1D	1994	4	84.00	Direct Injection, SOHC	110/150			
M9R	1995	4	84.00		110/150			
Qashqai 2.0L 02/07 → 223								
Qashqai 2.0L Allrad 02/07 →								
MR20DE	1997	4	84.00	Injection, DOHC	98/133			
Sentra 1.5L 01/82 → 12/86 224						BK440 (Graphite) (30-026185-10) → 11/83	DK440 (21-26185-25/0) → 11/83	GK440 → 11/83
E15S	1488	4	76.00	SOHC	52-55/ 71-75			
Sentra 1.6L 12V 07/88 → 08/90 225						BS610 (Graphite) (30-028240-00)	DS612	GS612
GA16	1597	4	76.00	SOHC				
Sentra 1.6L 16V 01/91 → 12/94 226							DP970 (21-28244-20/0)	GP970 (20-28244-00/0)
GA16DS	1597	4	76.00	DOHC				
Sentra 1.7L Diesel 01/82 → 12/87 227						BP580 (Graphite), 1,20mm (30-026734-10)	DP581 → 01/83 DP580 01/83 → 12/87	GP581 → 12/83 GP580 01/83 → 12/87
CD17	1680	4	80.00	SOHC				

								
HBS374 ® (22-70012B) M11x1.25x109mm (x10)			JM5137					 AE5200
								 BK440
								 BP580
								 BR240
	HA366   →12/82 HA371   01/83→ JC745  05/82→	JN494 →12/82 JN665	HC442 	PA203 (x8)	 NJ288 40x55x9mm, NBR  NJ280  33x47x8mm, NBR  NJ287  80x100x10mm, MVQ			 BS610
	HA371   JC745  HA372   1984→	JN494		PA203 (x8)	 NJ288 40x55x9mm, NBR  NJ286  36x49x7mm, NBR  NJ287  80x100x10mm, MVQ			 BV990
	HA371   JC745 	JN494 →12/84 JN665 →12/86 JN647 (50-028282-00) 01/87→	JJ429 03/85→ JJ430 09/85→	PA203 (x8)	 NJ288 40x55x9mm, NBR  NJ286  36x49x7mm, NBR  NJ287  80x100x10mm, MVQ			 HA366
	JC869  JC870 			PB071  (x4) PA874  (x8)				 JC869
	JC788  (x4)	JN653 JN654 (50-028288-00)	HC459 	PA874  (x8)	 NJ765  40x52x7mm, NBR  NJ284  84x104x11mm, FPM			 JD091
		JN528	JJ265	PA079  (x8)	 NJ283 36x50x8mm, NBR  NJ285 34x48x8mm, NBR  NJ280  33x47x8mm, NBR  NJ284  84x104x11mm, FPM			 JN494
HBS299 ® (22-29019B) M11x1.50x125.0mm (x10)	JD5402  (31-030008-00)			HR817  24-30614-78/0	 NA5215 28x42x5mm, FPM		HL5026 (245) 	 JN528
HBS373 ® (22-51110B) M12x1.50x131mm (x10)								 JN647
	JD5891  JD5892	HM5290 						 JN653
	HA371   →11/83 JC745  →11/83  JF031	JN494 →11/83 JN665 →11/83		PA203 (x8) →11/83	 NJ288 40x55x9mm, NBR →11/83  NJ286  36x49x7mm, NBR →11/83  NJ287  80x100x10mm, MVQ →11/83			 JN654
	JC869  JC870 			PB071  (x4) PA874  (x8)				 JN665
HBS187 ® (22-70001B) M10x1.50x97mm (x10)	JD093  JD091  (x2)	JN838 (50-028284-00)		PB681 (x16)	 NJ207 29x49x7.5mm, ACM  NJ765  40x52x7mm, NBR  NJ284  84x104x11mm, FPM			 JN838
		JN528		PA079  (x8)	 NJ283 36x50x8mm, NBR  NJ285 34x48x8mm, NBR  NJ280  33x47x8mm, NBR  NJ284  84x104x11mm, FPM			 JJ265
								 JJ429



KW/PS



Sentra 1.8L		01/00 → 08/06		228	AB5690 (MLS)	CB5611	FB5610
QG18DE	1769 1769 1769	4 4 4	80.00	Injection, DOHC	88/120 93/126 84-93/ 114- 126		
Sentra 2.0L		01/91 → 12/93		229		DT050 (21-28254-20/0) DT051■	GT050 GT051
SR20DE	1998	4	86.00	MPI, DOHC	85/115		
Serena 1.6L		10/94 → 08/00		230	BP960 (Graphite) (30-028243-00)	DP960 (21-28243-20/0)	GP960 (20-28243-00/0)
Serena 1.6L 16V		02/93 →			BV440 (Fibre) 01/94 →	DV440 01/94 →	GV440 01/94 →
GA16DE	1597	4	76.00	MPI, DOHC	66-75/ 90-102		
Serena 2.0L 16V		11/92 →		231	BV540 (Fibre) →06/96 AG5190 (Fibre), 1.3mm 07/96 →	DV541	EV540
SR20DE	1998	4	86.00	DOHC	92-118/ 125- 160		
Serena 2.0L D Diesel		11/92 →		232	BR360 (Graphite) (30-028364-00)	DR360 (21-28364-20/0)	GR360
LD20	1952	4	85.00		43-49/ 58-67		
Serena 2.0L D Diesel		01/80 → 12/90		233	BL310 (Graphite) →12/83 BR360 (Graphite) (30-028364-00) 01/84 →	DL310 →12/83 DR360 (21-28364-20/0) 01/86 →	GL310 →12/83 GR360 01/86 →
LD20	1952	4	85.00		43-49/ 58-67		
Serena SGX		09/00 →		234	AG5190 (Fibre), 1.3mm	DV541	EV540
SR20DE	1998	4	86.00	DOHC	92-118/ 125- 160		
Serena 2.3L D Diesel		01/95 →		235	AG5170 (MLS), 1.4mm, 1 Hole AG5180 (MLS), 1.45mm, 2 Holes AG5250 (MLS), 1.5mm, 3 Holes	CG5530▲	
LD23	2283	4	84.50		55/75		
Silvia 1.8L ZX Turbo		01/83 →		236	BM590 (Graphite) (30-028247-00)	DM590 →07/86 DM597 08/86 →	GM597○ [12] 08/86 →
CA18ET	1809	4	83.00	Injection, SOHC, Turbo	90-100/ 122- 136		
Silvia 2.0L		01/84 →		237	BM760 (Graphite) (30-026733-10) →12/88		GM760 →06/86
CA20E	1974	4	84.50	Injection, SOHC	72-85/ 98-116		
Silvia 2.4L 12V		01/89 → 12/92		238	BS770 (Graphite) (30-028258-00) →1990	DS770■ →1990 DS771■ (21-28258-21/0)	GS771
KA24E	2389	4	89.00	Injection, SOHC	85-98/ 116- 133		
Silvia 3.0L		01/86 →		239	BM570 (Graphite) (30-028270-00) →12/87	DM570 →12/87 DM574 01/88 →	GM574 01/88 →
VG30E	2960	6	87.00	Injection, SOHC	95-125/ 129- 170		

							 BL310 JN433 BM570 JN570 BM590 JN624 BM760 JN687 BP960 JN723 BR360 JN743 BS770 JN798 BV440 JN829 JN830 BV540 JC471 JJ265 JC472 JJ367 JC475 JC581 JC605 JC761 JC900 JC901 JC999 JD001 JD091 JD110
HBS188® (22-70002B) M11x1.50x157mm (x10)	JC995■ JF079	JN798 JN830 (50-028297-00)		PA874 (x16)	<input checked="" type="checkbox"/> NJ106■ 40x62x10mm, NBR <input checked="" type="checkbox"/> NJ284■ 84x104x11mm, FPM		
HBS187® (22-70001B) M10x1.50x97mm (x10)	JC999■ JD001■ JC761 JD110 JD091■ (x2)	JN829 (50-028283-00)	JH5100		<input checked="" type="checkbox"/> NJ207 29x49x7.5mm, ACM →12/94 <input checked="" type="checkbox"/> NJ765■ 40x52x7mm, NBR →12/94 <input checked="" type="checkbox"/> NJ284■ 84x104x11mm, FPM <input checked="" type="checkbox"/> NJ222■ 40x52x7mm, FPM 01/95→		
HBS188® (22-70002B) M11x1.50x157mm (x10)							
	JD5760	JN723	JH5097	PA933■ (x8)	<input checked="" type="checkbox"/> NJ045■ 48x70x9mm, NBR <input checked="" type="checkbox"/> NJ056■ 80x100x13mm, MVQ		
	JE747	JN687 →12/83 JN722 01/84→12/85 JN723 01/86→		PA933■ (x8)	<input checked="" type="checkbox"/> NJ045■ 48x70x9mm, NBR <input checked="" type="checkbox"/> NJ056■ 80x100x13mm, MVQ		
HBS188® (22-70002B) M11x1.50x157mm (x10)							
HBS195® (22-70011B) M12x1.75x165mm (x4) M12x1.75x135mm (x6)	JD5762	JM5282					
	JC605■ JC475■	JN433 →07/86	JJ265 →07/86 HC459■ 08/86→ JJ368 08/86→ JJ367 1987→	PA079■ (x8)	<input checked="" type="checkbox"/> NJ285 34x48x8mm, NBR <input checked="" type="checkbox"/> NJ280■ 33x47x8mm, NBR <input checked="" type="checkbox"/> NJ284■ 84x104x11mm, FPM	<input checked="" type="checkbox"/> NJ107 [2]■ <input checked="" type="checkbox"/> NJ106 [2]■ <input checked="" type="checkbox"/> NJ213 [2]■	
	JC605■ →12/88 JD029■ →12/87 JC475■ (x2) →12/88	JN433 →12/87 JN624 01/88→	JJ265 →12/87 JJ367 01/86→ JJ368 01/86→ HC459■ 01/87→	PA079■ (x8)	<input checked="" type="checkbox"/> NJ285 34x48x8mm, NBR <input checked="" type="checkbox"/> NJ280■ 33x47x8mm, NBR <input checked="" type="checkbox"/> NJ284■ 84x104x11mm, FPM		
	JC901■ JC900■	JN743 (50-028304-00)		PA933■ (x8) PA079■ (x8)	<input checked="" type="checkbox"/> NK106■ 46x58x7mm, ACM		
	JC581■ (x2) JC471■ JC472■	JN570 (x2)	JJ299 →12/87 HC460■ 01/88→	PA933■ (x6) PA079■ (x6)	<input checked="" type="checkbox"/> NJ285 (x2) 34x48x8mm, NBR <input checked="" type="checkbox"/> NJ368■ 33x47x7mm, NBR <input checked="" type="checkbox"/> NJ284■ 84x104x11mm, FPM	<input checked="" type="checkbox"/> NJ885 [2]■ 06/87→ <input checked="" type="checkbox"/> KA675 [13] →12/87	



KW/PS

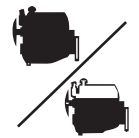

Skyline 1.8L					08/82 →	240	BK840 (Graphite)		
CA18S	1809	4	83.00	Injection, SOHC					
Skyline 1.8L 16V					01/86 → 12/90	241	BS050 (Graphite)	DS050	GS050
CA18D	1809	4	83.00	DOHC	92-95/ 125- 129		(30-028249-00)		
Skyline 2.0L					01/87 →	242	BR870 (Graphite)	DP870	
Skyline 2.0L GT					01/87 →			(21-25894-23/0)	
RB20E	1998	6	78.00	SOHC					
Stanza 1.6L					08/81 → 12/85	243	BK830 (Graphite)	DK831	
CA16S	1598	4	78.00	Injection, SOHC	60-66/ 82-90				
Stanza 1.8L					08/81 → 12/85	244	BK480 (Fibre)	DK840	
Stanza 1.8L SGL					03/83 → 12/85		(30-024578-10)		
CA18	1809	4	83.00	SOHC	65/88				
CA18S	1809	4	83.00	Injection, SOHC			BK840 (Graphite)		
Stanza 2.0L					01/88 → 12/90	245	BM760 (Graphite)	DM766	GM766
CA20E	1974	4	84.50	Injection, SOHC	72-85/ 98-116		(30-026733-10)		
Sunny 1.3L					08/82 → 08/90	246		DK447	GK444
E13	1270	4	76.00	SOHC	44/60				
Sunny 1.3L					03/82 → 09/87	247	BK440 (Graphite)	DK447	GK444
E13	1270	4	76.00	SOHC	44/60		(30-026185-10) 01/83 → 04/84		
Sunny 1.3L					06/86 → 10/91	248	BK440 (Graphite)	DK447	GK448
E13S	1269	4	76.00	Injection, SOHC	44/60		(30-026185-10)		
Sunny Coupe 1.3L					04/82 → 09/86	249	BK440 (Graphite)	DK441	GK444
E13	1270	4	76.00	SOHC	44/60		(30-026185-10) 01/83 → 04/84	01/83 → 04/84	GK441 01/83 → 04/84
Sunny 1.4L i					10/90 → 05/95	250	BP950 (Graphite)	DP950	GP950
Sunny 1.4L i 16V					10/90 → 06/95		(30-028874-00)		
Sunny 1.4L Mk III					10/90 → 06/95				
GA14DS	1392	4	73.60	DOHC	55/75				
GA14DE	1392	4	73.60	DOHC	55-64/ 75-87				
Sunny 1.4L LX					10/88 → 08/91	251	BV990 (Graphite)	DV990	GV990
GA14S	1392	4	73.60	Injection, SOHC	55-60/ 75-82				
Sunny 1.5L					03/82 → 10/88	252	BK440 (Graphite)	DK440	GK440
Sunny Coupe 1.5L					06/86 → 10/88		(30-026185-10)	(21-26185-25/0) → 11/83	→ 11/83
E15S	1488	4	76.00	SOHC	52-55/ 71-75			DK445 12/84 →	
Sunny 1.5L					01/80 →	253	BC270 (Graphite)	DC271	GC272
A15S	1488	4	76.00		51/69				
Sunny 1.5L					06/86 → 10/88	254	BK440 (Graphite)	DK445	
E15S	1488	4	76.00	SOHC	52-55/ 71-75		(30-026185-10)		







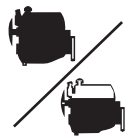



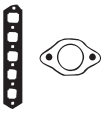

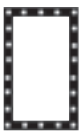

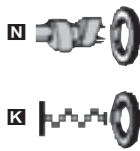

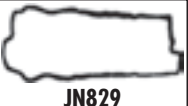





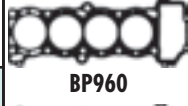























































		JC317	JN433	JJ265	PA079 (x8)	NJ285 34x48x8mm, NBR NJ280 33x47x8mm, NBR NJ284 84x104x11mm, FPM	BC270 JM008 BK440 JN433 BK480 JN494 BK830 JN624 BK840 JN640 BM760 JN647 BP950 JN654 BR870 JN665 BS050 JN838 BV990 JJ265 HA366 JJ367 JC057 JC317 JC475 JC605 JC653 JC745 JC788 JC869 JD091
		JC788 (x4)	JN654 (50-028288-00)	HC459	PA874 (x16)	NJ765 40x52x7mm, NBR NJ284 84x104x11mm, FPM	
		JC653	JN640		PA933 (x6) PA079 (x6)	NJ765 40x52x7mm, NBR NJ287 80x100x10mm, MVQ	
		JC317 JC475 (x2)	JN624	JJ265	PA079 (x8)	NJ285 34x48x8mm, NBR NJ280 33x47x8mm, NBR NJ284 84x104x11mm, FPM	NJ689 [38]
		JC317	JN433	JJ265	PA079 (x8)	NJ285 34x48x8mm, NBR NJ280 33x47x8mm, NBR NJ284 84x104x11mm, FPM	
		JC605 JC475 (x2)	JN624	HC459 JJ367 JJ368	PA079 (x8)	NJ285 34x48x8mm, NBR NJ280 33x47x8mm, NBR NJ284 84x104x11mm, FPM	
HBS409 (22-70017B)	HA366 01/83→04/84 JC745 05/82→12/86	JN494				NJ288 40x55x9mm, NBR NJ286 36x49x7mm, NBR NJ287 80x100x10mm, MVQ	
HBS409 (22-70017B)	HA366 01/83→04/84 JC745 05/82→12/86	JN494	HC442			NJ288 40x55x9mm, NBR NJ286 36x49x7mm, NBR NJ287 80x100x10mm, MVQ	
HBS409 (22-70017B)	HA371 JC745 03/87→ ☉ JF047		HC442	PA203 (x8)		NJ288 40x55x9mm, NBR NJ286 36x49x7mm, NBR NJ287 80x100x10mm, MVQ	
HBS409 (22-70017B)	HA366 01/83→04/84 JC745 05/82→12/86	JN494 01/83→04/84 JN665 01/83→04/84	HC442 01/83→04/84	PA203 (x8)		NJ288 40x55x9mm, NBR NJ286 36x49x7mm, NBR NJ287 80x100x10mm, MVQ	
HBS187 (22-70001B) M10x1.50x97mm (x10)	JD093 JD091	JN838 (50-028284-00)		PB681 (x16)		NJ207 29x49x7.5mm, ACM NJ765 40x52x7mm, NBR NJ284 84x104x11mm, FPM	
HBS187 (22-70001B) M10x1.50x97mm (x10)	JC869 JC870			PB071 (x4) PA874 (x8)		NJ765 40x52x7mm, NBR NJ284 84x104x11mm, FPM	
HBS409 (22-70017B) 01/86→	HA371 →11/83 JC745 (x2) HA372 →11/83	JN494 →11/83 JN665 →11/83	HC442 →11/83	PA203 (x8) →11/83		NJ288 40x55x9mm, NBR NJ286 36x49x7mm, NBR NJ287 80x100x10mm, MVQ →11/83	
	JC057	JM008 (31-026183-00)	HC259	KJ454 (x8)		NJ022 38x55x9mm, FPM/ACM NJ004 60x82x12mm, FPM/ACM	HG034 [43]
HBS409 (22-70017B)	JC745 (x2)	JN647 (50-028282-00)					



KW/PS

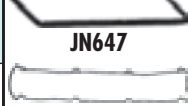
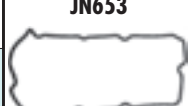

Sunny 1.5L 12V 08/87→10/90 255						DV991 ■ 04/88→	
GA15E	1497	4	73.60	Injection, SOHC			
Sunny 1.5L Mk I 03/82→05/86 256						DK440 (21-26185-25/0)	
E15	1488	4	76.00	Injection, SOHC	51/69		
Sunny 1.6L 04/00→ 257						CB5630	
QG16DE	1597	4	76.00	DOHC	78-80/ 106- 109		
Sunny 1.6L 06/86→10/88 258					BK440 (Graphite) (30-026185-10)	DK445 N13 only DK449 (21-26737-25/0) →12/86 DK446 (21-26737-26/0) 01/87→	GK447 01/87→
Sunny 1.6L i 06/86→10/90							
Sunny 1.6L i 4x4 06/86→05/89							
Sunny Coupe 1.6L 06/86→10/88							
Sunny Coupe 1.6L i 06/86→05/89							
E16i	1597	4	76.00	Injection, SOHC	54/73		
E16S	1597	4	76.00	SOHC	62/84		
Sunny 1.6L 06/86→10/88 259					BK440 (Graphite) (30-026185-10)	DK445	
Sunny 1.6L i 06/86→10/90							
E16i	1597	4	76.00	Injection, SOHC	54/73		
E16S	1597	4	76.00	SOHC	62/84		
Sunny 1.6L 16V 4x4 11/90→05/95 260					BP960 (Graphite) (30-028243-00)	DP960 (21-28243-20/0)	GP960 (20-28243-00/0)
Sunny 1.6L i 10/90→05/95							
GA16DE	1597	4	76.00	MPi, DOHC	66-75/ 90-102	GA16DE	
GA16DEL	1597	4	76.00	Injection, DOHC		BP970 (Graphite)	
GA16DS	1597	4	76.00	DOHC		GA16DS	
Sunny 1.6L GTI 16V 02/87→05/89 261					BR240 (Graphite)	DR240	ER241 GR240
Sunny Coupe 1.6L GTI 16V 05/87→05/89							
CA16D	1598	4	78.00	DOHC	81/110		
Sunny 1.6L i 10/90→03/00 262					BP960 (Graphite) (30-028243-00)	DP960 (21-28243-20/0)	GP960 (20-28243-00/0)
Sunny 1.6L i 16V 10/92→05/95							
Sunny 1.6L i 16V 4x4 10/92→03/00					BV440 (Fibre)	DV440 01/94→	GV440 01/94→
Sunny Van 1.6L i 16V 10/92→03/00					01/94→		
GA16DE	1597	4	76.00	MPi, DOHC	66-75/ 90-102		
GA16DEL	1597	4	76.00	Injection, DOHC			
GA16DS	1597	4	76.00	DOHC			
Sunny 1.6L i 12V 06/86→06/91 263					BS610 (Graphite) (30-028240-00)	DS610	GS610
Sunny 1.6L i 12V 4x4 10/88→08/90							
Sunny Coupe 1.6L i 12V 10/88→06/91							
GA16i	1597	4	76.00	SPi, SOHC	66/89		
Sunny 1.6L i 16V 4WD 4WD 10/90→05/95 264					BP970 (Graphite)	DP970 (21-28244-20/0)	GP970 (20-28244-00/0)
GA16DS	1597	4	76.00	DOHC			
Sunny 1.6L i 4x4 06/86→10/90 265					BK440 (Graphite) (30-026185-10)	DK445 N13 only	
E16i	1597	4	76.00	Injection, SOHC	54/73		
Sunny 1.6L L 11/92→04/96 266					BP960 (Graphite) (30-028243-00)	DP960 (21-28243-20/0)	GP960 (20-28243-00/0)
Sunny 1.6L Mk II 02/87→10/88							
Sunny 1.6L SR 4x4 Mk III 01/92→06/95							
GA16DE	1597	4	76.00	MPi, DOHC	66-75/ 90-102	GA16DE/L	
GA16DEL	1597	4	76.00	Injection, DOHC		BP970 (Graphite)	
						GA16DS	







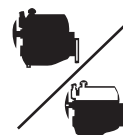



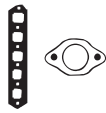

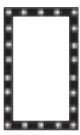

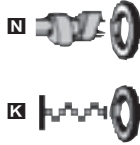







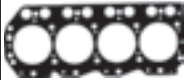







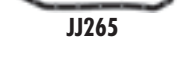











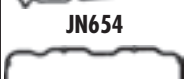

















































									
		JD244 			PB071  (x4) 04/88→ PA874  (x8) 04/88→	NJ765  40x52x7mm, NBR 04/88→ NJ284  84x104x11mm, FPM 04/88→		BP960 	JN838 
								BP970 	JJ429 
								BR240 	
HBS409 (22-70017B)	HA371   JC745  (x2) HA372  01/87→  JF031	JN665 01/85→12/86 JN647 (50-028282-00) 01/87→	HC442  →12/86 JJ429 →12/86 JJ430 09/85→12/86 HC458  01/87→	PA203 (x8)	NJ288  40x55x9mm, NBR NJ286  36x49x7mm, NBR NJ287  80x100x10mm, MVQ			BS610 	
HBS409 (22-70017B)		JN647 (50-028282-00)						BV440 	
HBS187  (22-70001B) M10x1.50x97mm (x10)	JD093  JD091  (x2)	JN829 (50-028283-00) GA16DE JN838 (50-028284-00) GA16DS	JH5100		NJ207  29x49x7.5mm, ACM NJ765  40x52x7mm, NBR NJ284  84x104x11mm, FPM			JC745 	
	JC788  (x4)	JN653 JN654 (50-028288-00)	HC459 	PA874  (x8)	NJ765  40x52x7mm, NBR NJ284  84x104x11mm, FPM			JC761 	
HBS187  (22-70001B) M10x1.50x97mm (x10)	JC999  JD001  JC761 JD110 JD091  (x2)	JN829 (50-028283-00)	JH5100		NJ207  29x49x7.5mm, ACM →12/94 NJ765  40x52x7mm, NBR →12/94 NJ284  84x104x11mm, FPM NJ222  40x52x7mm, FPM 01/94→			JC788 	
	JC869  JC870 		JH5100	PB071  (x4) PA874  (x8)	NJ765  40x52x7mm, NBR NJ284  84x104x11mm, FPM			JC869 	
HBS187  (22-70001B) M10x1.50x97mm (x10)	JD093  JD091  (x2)	JN838 (50-028284-00)		PB681 (x16)	NJ207  29x49x7.5mm, ACM NJ765  40x52x7mm, NBR NJ284  84x104x11mm, FPM			JC999 	
HBS409 (22-70017B)		JN647 (50-028282-00)						JD001 	
HBS187  (22-70001B) M10x1.50x97mm (x10)	JD093  JD091  (x2)		JH5100		NJ207  29x49x7.5mm, ACM NJ765  40x52x7mm, NBR NJ284  84x104x11mm, FPM			JD091 	
								JD110 	
								JD244 	
								JN647 	
								JN653 	
								JN654 	
								JN665 	



KW/PS



Sunny 1.7L D Diesel		03/82 → 06/91		267		BP580 (Graphite), 1,20mm (30-026734-10)	DP581 →12/86 DP580 01/87 →	GP581 →12/86 GP580 01/87 →
CD17	1680	4	80.00	SOHC	40/54			
Sunny Van 1.7L D Diesel		11/90 → 03/00						
Sunny 1.8L		04/00 → 09/03		268		AB5690 (MLS)	CB5611	FB5610
Sunny Coupe 1.8L		04/00 → 09/03						
QG18DE	1769	4	80.00	Injection, DOHC	84-93/ 114- 126			
Sunny 1.8L GTI 16V		01/89 → 06/91		269		BS050 (Graphite) (30-028249-00)	DS050	ER241 GS050
Sunny Coupe 1.8L GTI 16V		01/89 → 06/91						
CA18D	1809	4	83.00	DOHC	92-95/ 125- 129			
Sunny Coupe 1.8L ZX		01/89 → 12/91		270		BS050 (Graphite) (30-028249-00)	DS051	GS051
CA18DE	1809	4	83.00	DOHC	99/135			
Sunny 2.0L D Diesel		10/90 → 05/95		271		BW420 (MLS) (30-028861-00)	DW420	GW420 GW421 ▲
CD20	1974	4	84.50		55/75			
Sunny 2.0L D Diesel		06/91 → 03/00		272		BW420 (MLS) (30-028861-00)	DW420 01/96 →	GW421 ▲
CD20	1974	4	84.50		55/75			
Sunny 2.0L GTI 16V		10/90 → 05/95		273		BV540 (Fibre)	CY250 ■ DV540 ■	EV540 GV540
Sunny 2.0L i 16V		10/90 → 05/95						
SR20DE	1998	4	86.00	DOHC	92-118/ 125- 160			
Sunny 2.0L GTI-R 4x4		10/90 → 05/95		274		BV540 (Fibre)	DV541	EV540
SR20DET	1998	4	86.00		147/200			
Terrano 2.4L 4WD		05/96 → 01/02		275		BS770 (Graphite) (30-028258-00)	DS771 ■ (21-28258-21/0)	GS771
Terrano 2.4L i 12V 4WD		02/93 → 06/96						
KA24E	2389	4	89.00	Injection, SOHC	85-98/ 116- 133			
Terrano 2.4L i 4WD		10/87 → 02/93		276		BR660 (Graphite) (30-028261-00)	DR660 ■	GR661
Z24i	2389	4	89.00	SOHC	74-77/ 101- 105			
Terrano 2.7L TD 4WD Diesel		02/93 → 01/02		277		AC5750 (MLS), 1.20mm, 1 Notch (30-029544-00) AC5760 (MLS), 1.25mm, 2 Notches (30-029545-00) AC5770 (MLS), 1.30mm, 3 Notches (30-029546-00)	CC5750 ▲	
Terrano 2.7L TDi 4WD Diesel		05/96 →						
TD27T	2663	4	96.00		66-74/ 90-101			
TD27Ti	2664	4	96.00	Direct Injection, SOHC	92/125			
Terrano 2.7L TD 4WD Diesel		02/89 → 02/96		278		BS200 (MLS), 1.40mm (30-028265-00)	DS200 ■ →01/93 CC5750 ▲ 07/93 →	GS200
TD27T	2663	4	96.00		66-74/ 90-101			
Terrano 3.0L Di 4WD Diesel		05/02 →		279		AF5740 (MLS), 0.65mm, 1 Notch ZD30Ti AF5750 (MLS), 0.7mm, 2 Notches ZD30Ti	CF5740 ▲	FF5740 ▲
ZD30	2953	4	96.00	Direct Injection	110/150			
Terrano 3.0L DiTD 4WD Mk II Diesel		10/97 → 06/03		280				FF5740 ▲
ZD30DDTi	2953	4	96.00	Direct Injection, DOHC	116- 125/ 158- 170			







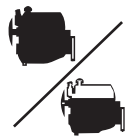



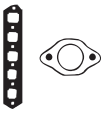

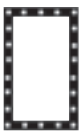





















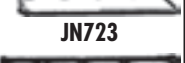
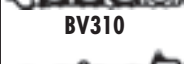



								
			JN528	JJ265	PA079  (x8)	 NJ283 36x50x8mm, NBR  NJ285 34x48x8mm, NBR  NJ280  33x47x8mm, NBR  NJ284  84x104x11mm, FPM		 AC5750, AC5760, AC5770  JN724  BP580  JN739  BR660  JN743  BS050  JN798  BS200  JJ265  BS770  BV540  BW420  JC133  JC580  JC605  JC760  JC788  JC806  JC900  JC901  JD134  JN528  JN654  JN702
		JC788  (x4)	JN654 (50-028288-00)	HC459 	PA874  (x16)	 NJ765  40x52x7mm, NBR  NJ284  84x104x11mm, FPM		
		JC605  JC788  (x4)	JN654 (50-028288-00)		PA874  (x16)	 NJ765  40x52x7mm, NBR  NJ284  84x104x11mm, FPM		
HBS111  (22-70006B) M11x1.50x119mm (x10)	JD5761	JM5138	HC5011 					
HBS111  (22-70006B) M11x1.50x119mm (x10)	JD5761	JM5138	HC5011 					
HBS188  (22-70002B) M11x1.50x157mm (x10)	JD134  JC760 	JN798		HR768  HR767 	 NJ106  40x62x10mm, NBR  NJ284  84x104x11mm, FPM			
HBS188  (22-70002B) M11x1.50x157mm (x10)								
HBS432  (22-70015B) M10x1.50x110.0mm (x10)	JC901  JC900 	JN739 (50-028301-00) JN743 (50-028304-00)		PA933  (x4) PA079  (x8)	 NK106  46x58x7mm, ACM			
	JC580  JC133  (x2)  JE747	JN702		PA933  (x8)	 NJ045  48x70x9mm, NBR  NJ056  80x100x13mm, MVQ			
HBS194  (22-70010B) M12x1.50x113mm (x18)	JC805  JC806  (x4)	JN724 (50-028308-00)		PA378 (x8)	 NJ831  58x80x10mm, NBR  NJ829  86x100x10mm, MVQ			
HBS194  (22-70010B) M12x1.50x113mm (x18)	JC805  JC806  (x4)	JN724 (50-028308-00)		PA378 (x8)	 NJ831  58x80x10mm, NBR  NJ829  86x100x10mm, MVQ			
		JM5318 ZD30Ti						

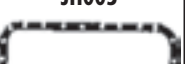

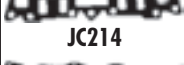
KW/PS



Terrano 3.0L i 4WD				01/90 → 12/95	281	BM570 (Graphite) (30-028270-00)	DM577	
VG30E	2960	6	87.00	Injection, SOHC	95-125/ 129- 170			
Terrano 3.3L 4WD Mk II				10/92 → 10/97	282			FF5690
Terrano 3.3L Mk II				10/92 → 10/97				
VG33E	3275	6	91.50	SOHC, V6	110- 125/ 150- 170			
UK 2.7L D Taxis-Blackcab Diesel				01/87 →	283	BS200 (MLS), 1.40mm (30-028265-00)	DS200 ■	GS200
TD27	2663	4	96.00	Indirect Injection	58-73/ 79-99			
Urvan 2.0L				05/87 → 05/97	284	BG720 (Graphite)	DG725 ■	GG725
Z20	1952	4	85.00	SOHC	64/87			
Urvan 2.0L				12/82 → 11/88	285	BG720 (Graphite)	DG724 (21-28250-20/0)	GG724
Z20	1952	4	85.00	SOHC	64/87			
Urvan 2.3L D Diesel				01/88 → 05/97	286	BS760 (MLS), 1.40mm	DS760 ■	GS760
TD23	2289	4	89.00	Indirect Injection	51-56/ 69-76			
Urvan 2.3L D Diesel				11/82 → 11/88	287	BM580 (Steel Elastomer) (30-028257-00)	DM580 ■ (21-28257-20/0) → 07/85 DM581 (21-28257-21/0) 08/85 →	GM580 → 07/85 GM581 08/85 →
SD23	2289	4	89.00		50-51/ 68-69			
Urvan 2.4L				05/01 →	288	BV310 (Graphite)	DV311	GV311
KA24DE	2389	4			103/140 98-110/ 133- 150			
	2389	4	89.00	DOHC				
Urvan 2.4L i				05/89 → 09/93	289	BR660 (Graphite) (30-028261-00)		GR661
Z24i	2389	4	89.00	SOHC	74-77/ 101- 105			
Urvan 2.5L D Diesel				12/88 → 05/97	290	BW540 (MLS), 1.40mm	DW540 ■ (21-28889-20/0)	GW540
TD25	2494	4	92.90	Indirect Injection	55-61/ 75-83			
Van 2.7L Diesel				01/87 →	291	BS200 (MLS), 1.40mm (30-028265-00)	DS200 ■	GS200
TD27	2663	4	96.00	Indirect Injection	58-73/ 79-99			
Vanette 1.5L				01/83 → 12/87	292	BK750 (Graphite)	DK750	GK750
A15	1488	4	76.00	Injection	51/69			
Vanette 1.6L i				01/95 →	293	BP960 (Graphite) (30-028243-00) BV440 (Fibre)	DP960 (21-28243-20/0) DV440 01/94 →	GP960 (20-28243-00/0) GV440 01/94 →
GAT6DE	1597	4	76.00	MPI, DOHC	66-75/ 90-102			
Vanette 2.0L D Diesel				07/91 → 01/95	294	BR360 (Graphite) (30-028364-00)	DR360 (21-28364-20/0)	
LD20II	1952	4	85.00	SOHC	44-49/ 60-67			
Vanette 2.0L D Diesel				10/86 → 12/95	295	BR360 (Graphite) (30-028364-00)	DR360 (21-28364-20/0)	GR360
LD20	1952	4	85.00		43-49/ 58-67			

									
HBS404 (22-70018B)								 BG720	 JC999
								 BK750	 JD001
								 BM570	 JD091
								 BM580	 JD110
								 BP960	 JM008
HBS194 ⊕ (22-70010B) M12x1.50x113mm (x18)	JC805 ■ JC806 ■ (x4)	JN724 (50-028308-00)		PA378 (x8)	NJ829 86x100x10mm, MVQ NJ831 58x80x10mm, NBR			 BR360	 JM086
	JC126 ■ JC133 ■ (x2)	JM086 (50-028281-00)	JH005	PA933 ■ (x8)	NJ045 ■ 48x70x9mm, NBR NJ056 ■ 80x100x13mm, MVQ			 BR660	 JN416
	JC126 ■ JC133 ■ (x2)	JM086 (50-028281-00)	JH005	PA933 ■ (x8)	NJ045 ■ 48x70x9mm, NBR NJ056 ■ 80x100x13mm, MVQ			 BR660	 JN687
HBS194 ⊕ (22-70010B) M12x1.50x113mm (x18)								 BS200	 JN702
	JC473 →07/85 JC668 08/85→	JN416 (50-028298-00) 01/84→	JJ281	PA378 (x8)	NJ369 ■ 58x80x12mm, MVQ NJ287 ■ 80x100x10mm, MVQ			 BS760	 JN723
	JC997 ■	JN880 HM5268 ■		PA079 (x16)	NK106 ■ 46x58x7mm, ACM			 BV310	 JN724
	JC580 ■ JC133 ■ (x2) ⊕JE747	JN702		PA933 ■ (x8)	NJ045 ■ 48x70x9mm, NBR NJ056 ■ 80x100x13mm, MVQ			 BV440	 JN829
	JC805 ■ JC806 ■ (x4)	JN724 (50-028308-00)		PA378 (x8)	NJ831 ■ 58x80x10mm, NBR NJ829 ■ 86x100x10mm, MVQ			 BW540	 JH005
HBS194 ⊕ (22-70010B) M12x1.50x113mm (x18)	JC805 ■ JC806 ■ (x4)	JN724 (50-028308-00)		PA378 (x8)	NJ831 ■ 58x80x10mm, NBR NJ829 ■ 86x100x10mm, MVQ			 JC126	 JJ281
	JC214	JM008 (31-026183-00)	HC259 ■	KJ454 (x8)	NJ022 ■ 38x55x9mm, FPM/ACM NJ004 ■ 60x82x12mm, FPM/ACM			 JC133	
HBS187 ⊕ (22-70001B) M10x1.50x97mm (x10)	JC999 ■ JD001 ■ JC761 JD110 JD091 ■ (x2)	JN829 (50-028283-00)	JH5100		NJ222 ■ 40x52x7mm, FPM NJ284 ■ 84x104x11mm, FPM			 JC214	
	JD5760	JN687	JH5097					 JC473	
	JD5760 ⊕JE747	JN687 JN723	JH5097	PA933 ■ (x8)	NJ045 ■ 48x70x9mm, NBR NJ056 ■ 80x100x13mm, MVQ			 JC580	
								 JC668	
								 JC761	
								 JC806	





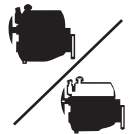













KWPS











Vanette 2.0L D Diesel				01/80 → 12/90	296	BL310 (Graphite) →12/83 BR360 (Graphite) (30-028364-00) 01/84 →	DL310 →12/83 DR360 (21-28364-20/0) 01/86 →	GL310 →12/83 GR360 01/86 →
LD20	1952	4	85.00		43-49/ 58-67			
Vanette 2.3L D Diesel				01/95 →	297	AG5170 (MLS), 1.4mm, 1 Hole AG5180 (MLS), 1.45mm, 2 Holes AG5250 (MLS), 1.5mm, 3 Holes	CG5530▲	
LD23	2283	4	84.50		55/75			
Vanette 2.4L i				10/86 → 12/95	298	BR660 (Graphite) (30-028261-00)		GR661
Z24i	2389	4	89.00	SOHC	74-77/ 101- 105			
X-Trail 2.0L				06/07 →	299			
X-Trail 2.0L FWD				03/07 →				
MR20DE	1997	4	84.00	Injection, DOHC	98/133			
X-Trail 2.0L				07/01 →	300		CF5541	FF5541
X-Trail 2.0L 4x4				07/01 →				
QR20DE	1998	4	89.00	DOHC	103- 110/ 140- 150			
X-Trail 2.2L dCi 4x4 Diesel				12/03 →	301	AD5260 (MLS), 0.8mm, 1 Hole	CD5260▲	
YD22DDTi	2184	4	86.00	Direct Injection, DOHC	84-100/ 114- 136			
X-Trail 2.2L Di 4x4 Diesel				07/01 →	302	AG9930 (MLS), 0,90mm AG9940 (MLS), 0,92mm, 1 Hole AG9950 (MLS), 0,95mm, 2 Holes AG9960 (MLS), 0,97mm, 3 Holes AG9970 (MLS), 1,00mm, 4 Holes AG9980 (MLS), 1,02mm, 5 Holes	CD5260▲	
YD22ETi	2184	4	86.00	Direct Injection	84/114			
X-Trail 2.5L 4x4				11/02 →	303	AF5540 (MLS)	CF5540	
QR25DE	2488	4	89.00	DOHC	121/165			

							 BL310 BR360 BR660 JC133 JC580 JN687 JN702 JN723
	JD5760 	JN687 01/83 → JN722 01/84 →12/85 JN723 01/86 →	JH5097	PA933E (x8)	<input checked="" type="checkbox"/> NJ045E 48x70x9mm, NBR <input checked="" type="checkbox"/> NJ056E 80x100x13mm, MVQ		
HBS195E <i>(22-70011B)</i> M12x1.75x165mm (x4) M12x1.75x135mm (x6)	JD5762	JM5282					
	JC580E JC133E (x2) 	JN702		PA933E (x8)	<input checked="" type="checkbox"/> NJ045E 48x70x9mm, NBR <input checked="" type="checkbox"/> NJ056E 80x100x13mm, MVQ		
	JD5891E JD5892	HM5290E					
HBS374E <i>(22-70012B)</i> M11x1.25x109mm (x10)		JM5137		PA5020 (x16) <i>(50-319496-00)</i>	<input checked="" type="checkbox"/> NJ369E 58x80x12mm, MVQ <input checked="" type="checkbox"/> NA5090E 76x94x8.5mm, FPM <i>(50-319499-00)</i>		
HBS374E <i>(22-70012B)</i> M11x1.25x109mm (x10)		JM5137					
		JM5267					

		CC			9			CC			9
10 N	Petrol	993	4	72.00	139	18 S	Petrol	1796	4	84.80	219
10 S	Petrol	993	4	72.00	94	18 SEH	Petrol	1796	4	84.80	197
11 N	Petrol	1078	4	75.00	140	18 SV	Petrol	1796	4	84.80	196
12 N	Petrol	1196	4	79.00	142	18 SV	Petrol	1796	4	84.80	265
12 N	Petrol	1196	4	79.00	170	18 SV	Petrol	1796	4	84.80	266
12 NC	Petrol	1196	4	79.00	101	20 E	Petrol	1979	4	95.00	169
12 NC	Petrol	1196	4	79.00	97	20 E	Petrol	1979	4	95.00	174
12 NV	Petrol	1196	4	77.80	102	20 E	Petrol	1979	4	95.00	221
12 NZ	Petrol	1195	4	72.00	99	20 EH	Petrol	1979	4	95.00	169
12 S	Petrol	1196	4	79.00	141	20 N	Petrol	1979	4	95.00	174
12 S	Petrol	1196	4	79.00	144	20 N	Petrol	1979	4	95.00	221
12 S	Petrol	1196	4	79.00	170	20 NE	Petrol	1998	4	86.00	166
12 S	Petrol	1196	4	79.00	171	20 NE	Petrol	1998	4	86.00	18
12 S	Petrol	1196	4	79.00	97	20 NE	Petrol	1998	4	86.00	277
12 SC	Petrol	1196	4	79.00	144	20 NEJ	Petrol	1998	4	86.00	278
12 SC	Petrol	1196	4	79.00	145	20 S	Petrol	1979	4	95.00	174
12 ST	Petrol	1196	4	77.80	102	20 S	Petrol	1979	4	95.00	221
12 ST	Petrol	1196	4	77.80	103	20 SE	Petrol	1998	4	86.00	198
12 ST	Petrol	1196	4	77.80	143	20 SE	Petrol	1998	4	86.00	200
13 N	Petrol	1297	4	75.00	147	20 SEH	Petrol	1998	4	86.00	166
13 N	Petrol	1297	4	75.00	9	20 SEH	Petrol	1998	4	86.00	18
13 NB	Petrol	1297	4	75.00	104	20 SEH	Petrol	1998	4	86.00	277
13 NB	Petrol	1297	4	75.00	105	20 XE	Petrol	1998	4	86.00	167
13 NB	Petrol	1297	4	75.00	147	20 XEJ	Petrol	1984	4	86.00	167
13 S	Petrol	1297	4	75.00	10	20 XEJ	Petrol	1984	4	86.00	271
13 S	Petrol	1297	4	75.00	148	22 E	Petrol	2197	4	95.00	187
13 S	Petrol	1297	4	75.00	149	22 E	Petrol	2197	4	95.00	223
13 S	Petrol	1297	4	75.00	172	22 E	Petrol	2197	4	95.00	226
13 SB	Petrol	1297	4	75.00	110	23 D	Diesel	2260	4	92.00	222
13 SB	Petrol	1297	4	75.00	111	23 D	Diesel	2260	4	92.00	224
14 NV	Petrol	1389	4	77.60	114	23 DTR	Diesel	2260	4	92.00	134
14 NV	Petrol	1389	4	77.60	150	23 DTR	Diesel	2260	4	92.00	208
14 NV	Petrol	1389	4	77.60	25	23 P	Petrol	2254	4	89.30	79
14 NV	Petrol	1389	4	77.60	252	23 TD	Diesel	2260	4	92.00	225
14 SE	Petrol	1389	4	77.60	26	23 TD	Diesel	2260	4	92.00	227
15 D (4EC1)	Diesel	1488	4	76.00	120	23 YD	Diesel	2260	4	92.00	207
15 D (4EC1)	Diesel	1488	4	76.00	152	23 YDT	Diesel	2260	4	92.00	208
15 DT (T4EC1)	Diesel	1488	4	76.00	120	25 DT	Diesel	2498	6	80.00	211
15 DT (T4EC1)	Diesel	1488	4	76.00	153	25 E	Petrol	2490	6	87.00	189
16 D	Diesel	1598	4	80.00	13	25 E	Petrol	2490	6	87.00	228
16 D	Diesel	1598	4	80.00	156	25 E	Petrol	2490	6	87.00	229
16 DA	Diesel	1598	4	80.00	13	25 NE	Petrol	2490	6	87.00	229
16 DA	Diesel	1598	4	80.00	156	25 TDS (VM41B)	Diesel	2500	4	92.00	136
16 DA	Diesel	1598	4	80.00	157	28 TDI (4JB1T)	Diesel	2771	4	93.00	137
16 LZ2	Petrol	1598	4	79.00	256	4 JA1	Diesel	2499	4	93.00	80
16 N	Petrol	1598	4	80.00	11	4 JA1T	Diesel	2499	4	93.00	80
16 SH	Petrol	1598	4	80.00	11	4 JG2T	Diesel	3059	4	95.40	81
16 SH	Petrol	1598	4	80.00	159	4 JX1	Diesel	2999	4	95.40	183
16 SV	Petrol	1598	4	79.00	12	4 ZD1	Petrol	2254	4	89.30	79
16 SV	Petrol	1598	4	79.00	155	4JG2TC	Diesel	3059	4	93.00	184
16 SV	Petrol	1598	4	79.00	255	6VD1	Petrol	3165	6	93.40	185
17 D	Diesel	1699	4	82.50	160	8140.23.2585	Diesel	2800	4	94.40	195
17 D	Diesel	1699	4	82.50	262	8140.23.3700	Diesel	2800	4	94.40	195
17 D	Diesel	1699	4	82.50	49	8140.43.2585	Diesel	2800	4	94.40	195
17 D (4EE1)	Diesel	1686	4	79.00	128	8140.43.3700	Diesel	2800	4	94.40	195
17 D (4EE1)	Diesel	1686	4	79.00	90	8140.43.3900	Diesel	2800	4	94.40	195
17 DR	Diesel	1699	4	82.50	160	C 12 NZ	Petrol	1195	4	72.00	82
17 DR	Diesel	1699	4	82.50	262	C 12 NZ	Petrol	1195	4	72.00	99
17 DR	Diesel	1699	4	82.50	48	C 13 N	Petrol	1297	4	75.00	104
17 DR	Diesel	1699	4	82.50	50	C 13 N	Petrol	1297	4	75.00	109
17 DT (TC4EE1)	Diesel	1686	4	79.00	263	C 13 N	Petrol	1297	4	75.00	146
17 DT (TC4EE1)	Diesel	1686	4	79.00	53	C 14 NZ	Petrol	1389	4	77.60	114
17 N	Petrol	1698	4	88.00	218	C 14 NZ	Petrol	1389	4	77.60	115
18 E	Petrol	1796	4	84.80	161	C 14 NZ	Petrol	1389	4	77.60	150
18 E	Petrol	1796	4	84.80	162	C 14 NZ	Petrol	1389	4	77.60	29
18 E	Petrol	1796	4	84.80	17	C 14 NZ	Petrol	1389	4	77.60	86
18 N	Petrol	1796	4	84.80	219	C 14 SE	Petrol	1389	4	77.60	116
18 NV	Petrol	1796	4	84.80	196	C 14 SE	Petrol	1389	4	77.60	151
18 S	Petrol	1796	4	84.80	173	C 14 SE	Petrol	1389	4	77.60	26
						C 14 SE	Petrol	1389	4	77.60	87

			CC			9				CC			9
C 14 SEL	Petrol		1389	4	77.60	116	F9Q 760	Diesel	1870	4	80.00	292	
C 16 LZ	Petrol		1598	4	79.00	14	F9Q 770	Diesel	1870	4	80.00	190	
C 16 LZ	Petrol		1598	4	79.00	158	F9Q 774	Diesel	1870	4	80.00	191	
C 16 NZ	Petrol		1598	4	79.00	121	F9Q 774	Diesel	1870	4	80.00	292	
C 16 NZ	Petrol		1598	4	79.00	14	F9Q762	Diesel	1870	4	80.00	293	
C 16 NZ	Petrol		1598	4	79.00	158	G9T 720	Diesel	2188	4	87.00	192	
C 16 NZ	Petrol		1598	4	79.00	259	G9U 720	Diesel	2463	4	89.00	194	
C 16 NZ	Petrol		1598	4	79.00	38	G9U 730	Diesel	2463	4	89.00	295	
C 16 NZ	Petrol		1598	4	79.00	40	G9U 754	Diesel	2463	4	89.00	194	
C 16 NZ2	Petrol		1598	4	79.00	259	H 20 E	Petrol	1979	4	95.00	186	
C 16 SE	Petrol		1598	4	79.00	122	H 25 E	Petrol	2490	6	87.00	188	
C 16 SE	Petrol		1598	4	79.00	43	LNF	Petrol	1998	4	86.00	138	
C 16 SEI	Petrol		1598	4	79.00	122	S 18 NV	Petrol	1796	4	84.80	16	
C 16 SEL	Petrol		1598	4	79.00	124	S 18 NV	Petrol	1796	4	84.80	163	
C 16 SEL	Petrol		1598	4	79.00	249	S 18 NV	Petrol	1796	4	84.80	165	
C 16 XE	Petrol		1598	4	79.00	123	S8U 758	Diesel	2499	4	93.00	8	
C 18 NE	Petrol		1796	4	84.80	16	S8U 770	Diesel	2499	4	93.00	193	
C 18 NE	Petrol		1796	4	84.80	162	S8U 780	Diesel	2499	4	93.00	8	
C 18 NT	Petrol		1796	4	84.80	162	S8U 782	Diesel	2499	4	93.00	8	
C 18 NT	Petrol		1796	4	84.80	163	S9W 702	Diesel	2799	4	94.40	195	
C 18 NT	Petrol		1796	4	84.80	164	X 10 XE	Petrol	973	3	72.50	95	
C 18 NV	Petrol		1796	4	84.80	220	X 12 SZ	Petrol	1195	4	72.00	82	
C 18 NZ	Petrol		1796	4	84.80	163	X 12 SZ	Petrol	1195	4	72.00	99	
C 18 NZ	Petrol		1796	4	84.80	164	X 12 XE	Petrol	1199	4	72.50	100	
C 18 NZ	Petrol		1796	4	84.80	265	X 12 XE	Petrol	1199	4	72.50	22	
C 18 XE	Petrol		1796	4	81.60	55	X 14 NZ	Petrol	1389	4	77.60	30	
C 18 XEL	Petrol		1796	4	81.60	56	X 14 SZ	Petrol	1389	4	77.60	115	
C 20 LET	Petrol		1998	4	86.00	280	X 14 SZ	Petrol	1389	4	77.60	119	
C 20 LET	Petrol		1998	4	86.00	76	X 14 SZ	Petrol	1389	4	77.60	86	
C 20 NE	Petrol		1998	4	86.00	130	X 14 XE	Petrol	1389	4	77.60	117	
C 20 NE	Petrol		1998	4	86.00	166	X 14 XE	Petrol	1389	4	77.60	248	
C 20 NE	Petrol		1998	4	86.00	18	X 14 XE	Petrol	1389	4	77.60	28	
C 20 NE	Petrol		1998	4	86.00	204	X 14 XE	Petrol	1389	4	77.60	31	
C 20 NE	Petrol		1998	4	86.00	277	X 14 XE	Petrol	1389	4	77.60	32	
C 20 NE	Petrol		1998	4	86.00	69	X 14 XE	Petrol	1389	4	77.60	88	
C 20 NE	Petrol		1998	4	86.00	70	X 15 DT (T4EC1)	Diesel	1488	4	76.00	120	
C 20 NE	Petrol		1998	4	86.00	73	X 16 SZ	Petrol	1598	4	79.00	257	
C 20 NEF	Petrol		1998	4	86.00	19	X 16 SZ	Petrol	1598	4	79.00	39	
C 20 NEF	Petrol		1998	4	86.00	199	X 16 SZR	Petrol	1598	4	79.00	258	
C 20 NEF	Petrol		1998	4	86.00	270	X 16 SZR	Petrol	1598	4	79.00	35	
C 20 NEJ	Petrol		1998	4	86.00	199	X 16 SZR	Petrol	1598	4	79.00	40	
C 20 SEL	Petrol		1998	4	86.00	279	X 16 SZR	Petrol	1598	4	79.00	45	
C 20 XE	Petrol		1998	4	86.00	168	X 16 XE	Petrol	1598	4	79.00	125	
C 20 XE	Petrol		1998	4	86.00	276	X 16 XE	Petrol	1598	4	79.00	250	
C 20 XE	Petrol		1998	4	86.00	68	X 16 XEL	Petrol	1598	4	79.00	261	
C 20 XE	Petrol		1998	4	86.00	74	X 16 XEL	Petrol	1598	4	79.00	297	
C 24 NE	Petrol		2410	4	95.00	135	X 16 XEL	Petrol	1598	4	79.00	36	
C 24 NE	Petrol		2410	4	95.00	209	X 16 XEL	Petrol	1598	4	79.00	41	
C 25 XE	Petrol		2498	6	81.60	287	X 16 XEL	Petrol	1598	4	79.00	42	
C 25 XE	Petrol		2498	6	81.60	77	X 17 D (4EE1)	Diesel	1686	4	79.00	128	
C 26 NE	Petrol		2594	6	88.80	213	X 17 D (4EE1)	Diesel	1686	4	79.00	90	
C 26 NE	Petrol		2594	6	88.80	230	X 17 DT (TC4EE1)	Diesel	1686	4	79.00	263	
C 30 SE	Petrol		2969	6	95.00	215	X 17 DT (TC4EE1)	Diesel	1686	4	79.00	53	
C 30 SE	Petrol		2969	6	95.00	231	X 17 DTL	Diesel	1699	4	82.50	52	
C 30 SEJ	Petrol		2969	6	95.00	215	X 18 XE	Petrol	1796	4	81.60	267	
C223	Diesel		2238	4	88.00	78	X 18 XE	Petrol	1796	4	81.60	56	
E 12 GV	Petrol		1196	4	79.00	101	X 18 XE1	Petrol	1796	4	80.50	267	
E 12 GV	Petrol		1196	4	79.00	97	X 18 XE1	Petrol	1796	4	80.50	299	
E 16 NZ	Petrol		1598	4	79.00	14	X 18 XE1	Petrol	1796	4	80.50	54	
E 16 NZ	Petrol		1598	4	79.00	158	X 20 DTH	Diesel	1995	4	84.00	203	
E 16 NZ	Petrol		1598	4	79.00	260	X 20 DTH	Diesel	1995	4	84.00	275	
E 16 SE	Petrol		1598	4	79.00	121	X 20 DTH	Diesel	1995	4	84.00	67	
E 18 NV	Petrol		1796	4	84.80	15	X 20 DTL	Diesel	1995	4	84.00	273	
E 18 NV	Petrol		1796	4	84.80	165	X 20 DTL	Diesel	1995	4	84.00	305	
E 18 NVR	Petrol		1796	4	84.80	196	X 20 DTL	Diesel	1995	4	84.00	66	
E 18 NVR	Petrol		1796	4	84.80	265	X 20 SE	Petrol	1998	4	86.00	130	
F4R 720	Petrol		1998	4	82.70	294	X 20 SE	Petrol	1998	4	86.00	201	
F8Q 600	Diesel		1870	4	80.00	7	X 20 XER	Petrol	1998	4	86.00	65	
F8Q 606	Diesel		1870	4	80.00	7	X 20 XEV	Petrol	1998	4	86.00	202	







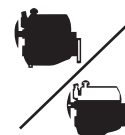



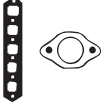

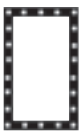

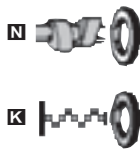

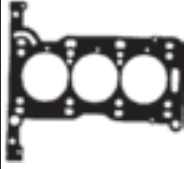
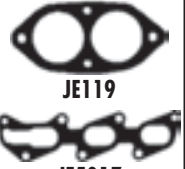

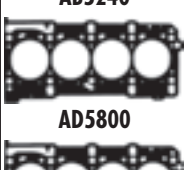
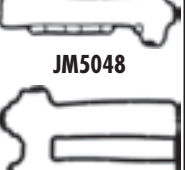

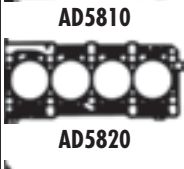
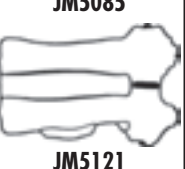
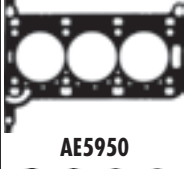
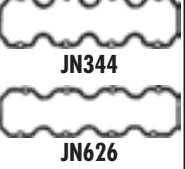

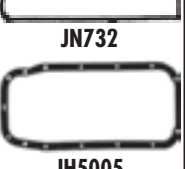
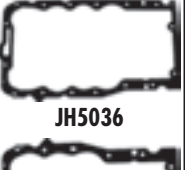
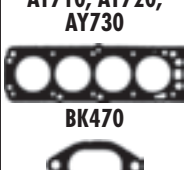
		CC			9			CC			9
X 20 XEV	Petrol	1998	4	86.00	279	Z 14 XEP	Petrol	1364	4	73.40	176
X 20 XEV	Petrol	1998	4	86.00	64	Z 14 XEP	Petrol	1364	4	73.40	247
X 20 XEV	Petrol	1998	4	86.00	75	Z 14 XEP	Petrol	1364	4	73.40	27
X 22 DTH	Diesel	2172	4	84.00	131	Z 14 XEP	Petrol	1364	4	73.40	85
X 22 DTH	Diesel	2172	4	84.00	241	Z 16 SE	Petrol	1598	4	79.00	178
X 22 SE	Petrol	2198	4	86.00	133	Z 16 SE	Petrol	1598	4	79.00	33
X 22 XE	Petrol	2198	4	86.00	132	Z 16 SE	Petrol	1598	4	79.00	89
X 22 XE	Petrol	2198	4	86.00	242	Z 16 XE	Petrol	1598	4	79.00	179
X 25 TD	Diesel	2498	6	80.00	211	Z 16 XE	Petrol	1598	4	79.00	253
X 25 XE	Petrol	2498	6	81.60	212	Z 16 XE	Petrol	1598	4	79.00	261
X 25 XE	Petrol	2498	6	81.60	286	Z 16 XE	Petrol	1598	4	79.00	297
X 25 XE	Petrol	2498	6	81.60	77	Z 16 XE	Petrol	1598	4	79.00	36
X 30 XE	Petrol	2962	6	86.00	216	Z 16 XE	Petrol	1598	4	79.00	44
X 30 XE	Petrol	2962	6	86.00	243	Z 16 XEP	Petrol	1598	4	79.00	177
Y 13 DT	Diesel	1248	4	69.80	83	Z 16 XEP	Petrol	1598	4	79.00	254
Y 16 XE	Petrol	1598	4	79.00	261	Z 16 XEP	Petrol	1598	4	79.00	296
Y 17 DT	Diesel	1686	4	79.00	127	Z 16 XEP	Petrol	1598	4	79.00	34
Y 17 DT	Diesel	1686	4	79.00	181	Z 16 YNG	Gas	1598	4	79.00	298
Y 17 DT	Diesel	1686	4	79.00	51	Z 16 YNG	Gas	1598	4	79.00	37
Y 17 DT	Diesel	1686	4	79.00	91	Z 17 DTH	Diesel	1686	4	79.00	126
Y 17 DTL	Diesel	1686	4	79.00	127	Z 17 DTH	Diesel	1686	4	79.00	180
Y 17 DTL	Diesel	1686	4	79.00	91	Z 17 DTH	Diesel	1686	4	79.00	47
Y 20 DTH	Diesel	1995	4	84.00	235	Z 17 DTL	Diesel	1686	4	79.00	46
Y 20 DTH	Diesel	1995	4	84.00	274	Z 18 XE	Petrol	1796	4	80.50	129
Y 20 DTH	Diesel	1995	4	84.00	275	Z 18 XE	Petrol	1796	4	80.50	182
Y 20 DTH	Diesel	1995	4	84.00	306	Z 18 XE	Petrol	1796	4	80.50	232
Y 20 DTH	Diesel	1995	4	84.00	67	Z 18 XE	Petrol	1796	4	80.50	251
Y 20 DTL	Diesel	1995	4	84.00	66	Z 18 XE	Petrol	1796	4	80.50	264
Y 22 DTH	Diesel	2172	4	84.00	131	Z 18 XE	Petrol	1796	4	80.50	300
Y 22 DTH	Diesel	2172	4	84.00	206	Z 18 XEL	Petrol	1796	4	80.50	264
Y 22 DTR	Diesel	2172	4	84.00	238	Z 19 DT	Diesel	1910	4	82.00	233
Y 22 DTR	Diesel	2172	4	84.00	284	Z 19 DT	Diesel	1910	4	82.00	268
Y 22 DTR	Diesel	2172	4	84.00	285	Z 19 DT	Diesel	1910	4	82.00	302
Y 22 DTR	Diesel	2172	4	84.00	309	Z 19 DT	Diesel	1910	4	82.00	58
Y 22 DTR	Diesel	2172	4	84.00	72	Z 19 DTH	Diesel	1910	4	82.00	234
Y 22 SE	Petrol	2198	4	86.00	133	Z 19 DTH	Diesel	1910	4	82.00	269
Y 22 XE	Petrol	2198	4	86.00	205	Z 19 DTH	Diesel	1910	4	82.00	301
Y 25 DT	Diesel	2497	6	80.00	210	Z 19 DTH	Diesel	1910	4	82.00	57
Y 26 SE	Petrol	2597	6	83.20	214	Z 19 DTH	Diesel	1910	4	82.00	59
Y 26 SE	Petrol	2597	6	83.20	288	Z 19 DTJ	Diesel	1910	4	82.00	59
Y 30 DT	Diesel	2958	6	87.50	239	Z 19 DTJ	Diesel	1910	4	82.00	60
Y 30 DT	Diesel	2958	6	87.50	289	Z 19 DTL	Diesel	1910	4	82.00	61
Y 32 SE	Petrol	3175	6	87.50	217	Z 20 LEH	Petrol	1998	4	86.00	304
Z 10 XE	Petrol	973	3	72.50	2	Z 20 LEH	Petrol	1998	4	86.00	62
Z 10 XE	Petrol	973	3	72.50	92	Z 20 LEL	Petrol	1998	4	86.00	63
Z 10 XEP	Petrol	998	3	73.40	1	Z 20 LER	Petrol	1998	4	86.00	303
Z 10 XEP	Petrol	998	3	73.40	20	Z 20 LER	Petrol	1998	4	86.00	63
Z 10 XEP	Petrol	998	3	73.40	93	Z 20 LET	Petrol	1998	4	86.00	244
Z 12 XE	Petrol	1199	4	72.50	23	Z 20 LET	Petrol	1998	4	86.00	303
Z 12 XE	Petrol	1199	4	72.50	3	Z 20 LET	Petrol	1998	4	86.00	63
Z 12 XE	Petrol	1199	4	72.50	96	Z 20 NET	Petrol	1998	4	86.00	236
Z 12 XEP	Petrol	1229	4	73.40	21	Z 20 NET	Petrol	1998	4	86.00	272
Z 12 XEP	Petrol	1229	4	73.40	4	Z 20 NHH	Petrol	1998	4	86.00	138
Z 12 XEP	Petrol	1229	4	73.40	98	Z 22 SE	Petrol	2198	4	86.00	245
Z 13 DT	Diesel	1248	4	69.80	106	Z 22 SE	Petrol	2198	4	86.00	281
Z 13 DT	Diesel	1248	4	69.80	246	Z 22 SE	Petrol	2198	4	86.00	308
Z 13 DT	Diesel	1248	4	69.80	5	Z 22 SE	Petrol	2198	4	86.00	71
Z 13 DT	Diesel	1248	4	69.80	83	Z 22 XE	Petrol	2198	4	86.00	205
Z 13 DTH	Diesel	1248	4	69.60	108	Z 22 YH	Petrol	2198	4	86.00	237
Z 13 DTH	Diesel	1248	4	69.60	24	Z 22 YH	Petrol	2198	4	86.00	282
Z 13 DTJ	Diesel	1248	4	69.60	107	Z 22 YH	Petrol	2198	4	86.00	283
Z 13 DTJ	Diesel	1248	4	69.60	175	Z 22 YH	Petrol	2198	4	86.00	307
Z 13 DTJ	Diesel	1248	4	69.60	6	Z 30 DT	Diesel	2958	6	87.50	239
Z 13 DTJ	Diesel	1248	4	69.60	84	Z 30 DT	Diesel	2958	6	87.50	289
Z 14 XE	Petrol	1389	4	77.60	112	Z 30 DT	Diesel	2958	6	87.50	290
Z 14 XE	Petrol	1389	4	77.60	28	Z 32 SE	Petrol	3175	6	88.50	240
Z 14 XEL	Petrol	1364	4	77.00	27	Z 32 SE	Petrol	3175	6	88.50	291
Z 14 XEP	Petrol	1364	4	73.40	113						
Z 14 XEP	Petrol	1364	4	73.40	118						

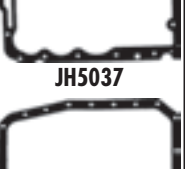
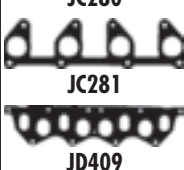

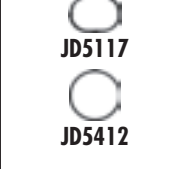
KW/PS

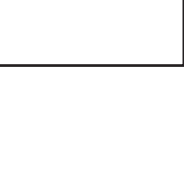

Agila 1.0L		08/03 →			1	AE5950 (Steel) (30-029101-00)	CE5950 (21-29101-00/0)	
Z 10 XEP	998	3	73.40	Injection, DOHC	44/60			
Agila 1.0L 12V		09/00 →			2	AB5140 (MLS) (30-028029-00)	CB5141 ■ ☒ (21-28029-21/0)	EB5140 (22-29175-00/0)
Z 10 XE	973	3	72.50	Injection, DOHC	43/58			
Agila 1.2L 16V		09/00 →			3	AB5240 (MLS) (30-028390-20) → Ch.36999999 AH5030 (MLS) (30-030366-00) Ch.46000001 →	CB5240 ■ ☒ (21-28390-21/0) → Ch.36999999 CH5030 (21-30366-00/0) Ch.46000001 →	EB5240 (22-29169-00/0)
Z 12 XE	1199	4	72.50	Injection, DOHC	55/75			
Agila 1.2L 16V Twinport		07/04 →			4	AH5030 (MLS) (30-030366-00)	CH5031 (21-30366-01/0)	
Z 12 XEP	1229	4	73.40	Injection, DOHC	59/80			
Agila 1.3L CDTI Diesel		08/03 →			5	AD5800 (MLS), 0.72mm (30-029762-00) AD5810 (MLS), 0.82mm, 1 Hole (30-029763-00) AD5820 (MLS), 0.92mm, 2 Holes (30-029764-00)	CD5800▲ (21-29762-20/0)	
Z 13 DT	1248	4	69.80	Direct Injection	51/70			
Agila 1.3L CDTI Diesel		09/07 →			6	AD5800 (MLS), 0.72mm (30-029762-00) AD5810 (MLS), 0.82mm, 1 Hole (30-029763-00) AD5820 (MLS), 0.92mm, 2 Holes (30-029764-00)		
Z 13 DTJ	1248	4	69.60	Direct Injection	55/75			
Arena 1.9L D Diesel		03/98 → 08/01			7	AY710 (Steel Elastomer), 1.36mm, 2 Holes (30-029016-00) → 0.073mm AY720 (Steel Elastomer), 1.44mm, 1 Hole (30-029017-00) → 0.073 → 0.206mm AY730 (Steel Elastomer), 1.52mm, 3 Holes (30-029018-00) → 0.206mm →	DL961▲ (21-26632-21/0)	EL960 [8] (22-27574-00/0)
Arena Van 1.9L D Diesel		03/98 → 08/01						
F8Q 600/F8Q 606	1870	4	80.00		44/60			
Arena 2.5L D Diesel		03/98 → 08/01			8	AY290 (Fibre), 1.60mm [112] (30-027426-00) AY300 (Fibre), 1.70mm [112] (30-026654-20) AY310 (Fibre), 1.80mm [112] (30-026655-20)	DE588▲ [109] (21-26037-23/0)	FY291▲ [12] (20-27426-00/0)
Arena Van 2.5L D Diesel		03/98 → 08/01						
S8U 780/S8U 782	2499	4	93.00		55/75			
S8U 758	2499	4	93.00		55-58/ 75-79			
Ascona 1.3L N		09/81 → 08/86			9	BK470 (Fibre) (30-024033-10)	DK470 (21-24033-26/0) → Ch.C1535880 DK471 (21-24033-30/0) Ch.C1535881 →	EK470 (22-27194-05/0) GK470 (20-24033-01/0)
I3 N	1297	4	75.00	SOHC	39-44/ 53-60			











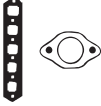

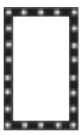

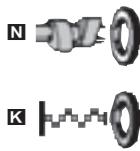















								
HBS253 Ⓢ [22-29015B] M8x1.25x119mm (x10) →Eng.19AQ2640	JD5904 ■ (x4) (50-030368-00) (FPM) JE5017 ■ (31-029177-00)	JM5121 (50-029185-00)	JH5037 (31-029175-00)	PA5025 (x12) (50-319386-00) HR5096 ■ (24-31938-61/0)	NA5108 ■ 42x55x7mm, FPM (50-319392-00) NB698 ■ 80x98x10mm, FPM (50-319273-00)	JR5030 [11]		 AB5140  JE119  JE5017  JE5024
HBS253 Ⓢ [22-29015B] M8x1.25x119mm (x10)	JD5117 ■ (x3) (50-029186-00) JE5017 ■ (31-029177-00)	JM5085 (50-029176-00) →Eng.1G001110 JM5121 (50-029185-00) Eng.1G001111→	JH5037 (31-029175-00)	PA5025 (x12) (50-319386-00) HR5096 ■ (24-31938-61/0)	NA5108 ■ 42x55x7mm, FPM (50-319392-00) NB698 ■ 80x98x10mm, FPM (50-319273-00)	JR5030 [11]		 AB5240  AD5800  JM5048
HBS252 Ⓢ [22-29014B] M8x1.25x119mm (x12)	JD5117 ■ (x4) (50-029186-00) →Ch.3G999999 JD5904 ■ (x4) (50-030368-00) (FPM) Ch.4G000001→ JE5024 ■ (31-029170-00)	JM5048 (50-029167-00) →Ch.1G001502 JM5071 (50-029232-00) Ch.1G001503→	JH5036 (31-029169-00)	HR5048 ■ (24-31938-60/0)	NA5108 ■ 42x55x7mm, FPM (50-319392-00) NB698 ■ 80x98x10mm, FPM (50-319273-00)	JR5030 [11]		 AD5810  JM5085  AD5820  JM5121
HBS252 Ⓢ [22-29014B] M8x1.25x119mm (x12)	JD5904 ■ (x4) (50-030368-00) (FPM)	JM5071 (50-029232-00)	JH5036 (31-029169-00)	HR5048 ■ (24-31938-60/0)	NA5108 ■ 42x55x7mm, FPM (50-319392-00) NB698 ■ 80x98x10mm, FPM (50-319273-00)	JR5030 [11]		 AE950  JN344  JN626
HBS353 Ⓢ [22-17025B] M10x1.25x119mm (x10)	JD5411 ■ (50-030025-00) JD5412 ■ (50-030026-00) JD5413 ■ (31-030027-00) (MLS)	JM5259 (31-030023-00)	HR397 [57] 34-000410-00	HR5088 ■ (24-31952-10/0)	NA5223 ■ 40x52x7mm, FPM (50-319520-00) NA5230 ■ 78x100x9mm, PTFE (50-319522-00)	KK5646 [45]		 AY290, AY300, AY310  JN732  JH5005
HBS353 Ⓢ [22-17025B] M10x1.25x119mm (x10)	JD5413 ■ (31-030027-00) (MLS)		HR397 [57] 34-000410-00	HR5088 ■ (24-31952-10/0)	NA5223 ■ 40x52x7mm, FPM (50-319520-00) NA5230 ■ 78x100x9mm, PTFE (50-319522-00)			 AY710, AY720, AY730  JH5036
HBS244 Ⓢ [22-51103B] M12x1.50x111mm (x10)	JD409 (31-026628-10)	JN732 (50-026632-00)	JJ557 ● PA349 (33-102290-10) 22x16x2mm	HR569 ■ 24-30667-00/0	NF846 25x42x7mm, FPM/ACM (50-319516-00) NF843 ■ 50x68x10mm, FPM/ACM (50-305667-70) NF850 ■ 85x105x8mm, FPM (50-319183-00)			 JC054  JC055  JH5037
HBS011 Ⓢ [22-51004B] M12x1.25x160mm (x10) M12x1.25x119mm (x12)	JC054 ■ (x4) (31-024274-10) JC055 ■ (x4) (31-025031-10)		JJ100					 JJ100  JJ120
HBS002 Ⓢ [22-29098B] M10x1.25x140mm (x10)	JC280 ■ (31-024313-10) JC281 ■ (31-024312-10) ● JE119 (31-024520-00)	JN344 (31-024299-00) →Ch.C1535880 JN626 (31-026099-10) Ch.C1535881→	JH5005 [116] (31-027194-00) JJ120	HR342 ■ (24-30590-05/0)	NC006 ■ 35x48x7mm, MVQ (50-319161-00) NB697 ■ 26x42x8mm, FPM (50-306704-00) NB698 ■ 80x98x10mm, FPM (50-319273-00)	NB575 [2]■		 JD409  JD5117 JD5412 JJ557



KW/PS



Ascona 1.3L S						09/81 → 08/88	10	BK470 (Fibre) (30-024033-10)	DK470 (21-24033-26/0) → Eng.13519417531 DK471 (21-24033-30/0) Eng.13519417532 →	EK470 (22-27194-05/0) GK470 (20-24033-01/0)
13 S	1297	4	75.00	Injection, SOHC	42-55/ 57-75					
Ascona 1.6L						09/81 → 08/88	11	BK480 (Fibre) (30-024578-10)	DK480 (21-24578-22/0)	
Ascona 1.6L S						09/81 → 08/86				
16 N	1598	4	80.00	Carburettor, SOHC	55/75					
16 SH	1598	4	80.00	SOHC	66/89					
Ascona 1.6L						09/86 → 08/88	12	BP800 (Fibre) (30-025706-20)	DP800 (21-25706-26/0)	EK484 [129] (22-27194-01/0)
16 SV	1598	4	79.00	Carburettor, SOHC	60/82					
Ascona 1.6L D Diesel						03/82 → 08/88	13	BLO10 (Fibre), 1.40mm (30-025124-10) → 0.75mm BLO20 (Fibre), 1.50mm, 1 Notch (30-025125-10) → 0.75 → 0.85mm BLO30 (Fibre), 1.60mm, 2 Notches (30-025126-10) → 0.85mm →	DLO10▲ (25-24572-02/0) → 12/85 DLO11▲ (21-26198-20/0) 01/86 →	EK481 (22-25011-00/0) → 12/85 EK485 (22-25011-04/0) 01/86 →
16 D/16 DA	1598	4	80.00	SOHC	40/54					
Ascona 1.6L i						09/86 → 08/88	14	BP800 (Fibre) (30-025706-20)	DP802 (21-25706-25/0)	EK484 [129] (22-27194-01/0)
C 16 LZ/ C 16 NZ/E 16 NZ	1598	4	79.00	SPi, SOHC	55/75					
Ascona 1.8L						09/87 → 08/88	15	BP810 (Fibre) (30-025818-10)	DP810 (21-25818-22/0)	EK482 (22-26131-01/0)
E 18 NV	1796	4	84.80	Carburettor, SOHC	62/84					
Ascona 1.8L E						01/85 → 08/86	16	BM380 (Fibre) (30-024765-10) C18NE BP810 (Fibre) (30-025818-10) S18NV	DM381 (21-24765-23/0) C18NE DP810 (21-25818-22/0) S18NV	EK482 (22-26131-01/0) S18NV
S 18 NV	1796	4	84.80	Injection, SOHC	62-74/ 84-101					
C 18 NE	1796	4	84.80	Injection, SOHC	74/100					
Ascona 1.8L i						09/82 → 08/86	17	BM380 (Fibre) (30-024765-10)	DM381 (21-24765-23/0)	
18 E	1796	4	84.80	MPi, SOHC	82-85/ 112- 115					







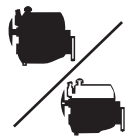



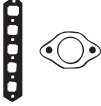

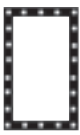

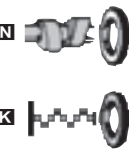

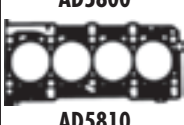
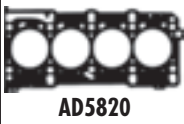
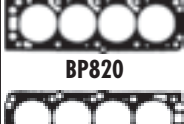

								
HBS002 ⊕ (22-29098B) M10x1.25x140mm (x10)	JC280 ■ (31-024313-10) JC281 ■ (31-024312-10) ⊕ JE119 (31-024520-00)	JN344 (31-024299-00) →Eng.13519417531 JN626 (31-026099-10) Eng.13519417532→	JH5005 [116] (31-027194-00) JJ120	HR342 ■ (24-30590-05/0)	NC006 ■ 35x48x7mm, MVQ (50-319161-00) NB697 ■ 26x42x8mm, FPM (50-306704-00) NB698 ■ 80x98x10mm, FPM (50-319273-00)	NB575 [2]■		 BK470  BK480  BLO10, BLO20, BLO30  BM380  BP800  BP810  JC280  JC281  JC282  JC283  JC436  JC437  JC757  JC824  JE119  JE120  JN344  JN453  JN626  JN693
HBS003 ⊕ (22-29009B) M11x1.25x140mm (x10)	JC283 ■ (31-025183-10) JC282 ■ (31-024625-20) ⊕ JE120 (31-024767-00)	JN453 [127] (31-024572-00)	JJ200 (31-025011-00)	HR343 ■ (24-30602-50/0)	NC006 ■ 35x48x7mm, MVQ (50-319161-00) NB700 ■ 31x50x8mm, FPM (50-306551-50) NB701 ■ 86x104x11mm, FPM (50-306261-50)	NB575 [2]■		 JH5005  JJ120  JJ200  JJ385
HBS002 ⊕ (22-29098B) M10x1.25x140mm (x10)	JC824 ■ (31-026334-00) JC281 ■ (31-024312-10) ⊕ JE120 (31-024767-00)	JN626 (31-026099-10)	JH5005 (x2) [116] (31-027194-00) JJ120 (x2)	PA565 (x8) (50-305900-50) HR342 ■ (24-30590-05/0)	NC006 ■ 35x48x7mm, MVQ (50-319161-00) NB697 ■ 26x42x8mm, FPM (50-306704-00) NB698 ■ 80x98x10mm, FPM (50-319273-00)	NB575 [2]■		
HBS074 ⊕ (22-29100B) M11x1.25x154mm (x10)	JC436 ■ (31-028012-00) JC437 ■ (31-024854-10) ⊕ JE119 (31-024520-00)	JN453 [127] (31-024572-00) →12/85 JN693 [128] (31-026198-10) 01/86→	JJ200 (31-025011-00)	HR343 ■ (24-30602-50/0)	NC006 ■ 35x48x7mm, MVQ (50-319161-00) NB734 ■ 35x50x8mm, FPM NB701 ■ 86x104x11mm, FPM (50-306261-50) →12/85 NB806 ■ 90x104x11mm, FPM (50-306552-00) 01/86→	NB575 [2]■		
HBS002 ⊕ (22-29098B) M10x1.25x140mm (x10)	JC824 ■ (31-026334-00) JC281 ■ (31-024312-10)	JN626 (31-026099-10)	JH5005 (x2) [116] (31-027194-00) JJ120 (x2)	PA565 (x8) (50-305900-50) HR342 ■ (24-30590-05/0)	NC006 ■ 35x48x7mm, MVQ (50-319161-00) NB697 ■ 26x42x8mm, FPM (50-306704-00) NB698 ■ 80x98x10mm, FPM (50-319273-00)	NB575 [2]■		
HBS003 ⊕ (22-29009B) M11x1.25x140mm (x10)	JC757 ■ (31-025817-10) JC282 ■ (31-024625-20) ⊕ JE120 (31-024767-00)	JN693 [128] (31-026198-10)	JJ385 [148] (50-026131-00)	PA565 (x8) (50-305900-50) HR342 ■ (24-30590-05/0)	NC006 ■ 35x48x7mm, MVQ (50-319161-00) NB700 ■ 31x50x8mm, FPM (50-306551-50) NB806 ■ 90x104x11mm, FPM (50-306552-00)	NB575 [2]■ NB807 [2]■		
HBS003 ⊕ (22-29009B) M11x1.25x140mm (x10)	JC283 ■ (31-025183-10) C18NE JC757 ■ (31-025817-10) S18NV JC282 ■ (31-024625-20) ⊕ JE120 (31-024767-00)	JN453 [127] (31-024572-00) C18NE JN693 [128] (31-026198-10) S18NV	JJ200 (31-025011-00) C18NE JJ385 [148] (50-026131-00) S18NV	PA565 (x8) (50-305900-50) HR342 ■ (24-30590-05/0) HR343 ■ (24-30602-50/0) C18NE	NC006 ■ 35x48x7mm, MVQ (50-319161-00) NB700 ■ 31x50x8mm, FPM (50-306551-50) NB701 ■ 86x104x11mm, FPM (50-306261-50) →12/85 NB806 ■ 90x104x11mm, FPM (50-306552-00) 01/86→	NB575 [2]■ NB807 [2]■		
HBS003 ⊕ (22-29009B) M11x1.25x140mm (x10)	JC283 ■ (31-025183-10) JC282 ■ (31-024625-20) ⊕ JE120 (31-024767-00)	JN453 [127] (31-024572-00)	JJ200 (31-025011-00)	HR343 ■ (24-30602-50/0)	NC006 ■ 35x48x7mm, MVQ (50-319161-00) NB700 ■ 31x50x8mm, FPM (50-306551-50) NB701 ■ 86x104x11mm, FPM (50-306261-50)	NB575 [2]■		

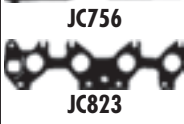

KW/PS

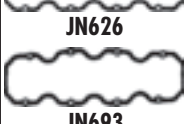

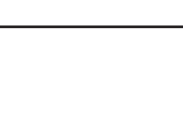
Ascona 2.0L i						09/86 → 08/88	18	BP820 (Fibre)	DP820	EK482
Ascona 2.0L i GT						03/87 → 08/88		(30-025819-10)	(21-25819-21/0)	(22-26131-01/0)
20 NE/C 20 NE	1998	4	86.00	MPI, SOHC	85/115					
20 SEH	1998	4	86.00	MPI, SOHC	95/129					
Ascona 2.0L i						08/87 → 08/88	19	BP820 (Fibre)	DP820	EK482
C 20 NEF								(30-025819-10)	(21-25819-21/0)	(22-26131-01/0)
1998	4	86.00	MPI, SOHC		74/100					
Astra 1.0L						08/03 → 05/04	20		CE5950	
Z 10 XEP									(21-29101-00/0)	
998	3	73.40	Injection, DOHC		44/60					
Astra 1.2L						08/05 →	21	AH5030 (MLS)	CH5031	
Z 12 XEP								(30-030366-00)	(21-30366-01/0)	
1229	4	73.40	Injection, DOHC		59/80					
Astra 1.2L 16V						02/98 → 09/00	22	AB5240 (MLS)	CB5241	EB5240
X 12 XE								(30-028390-20)	(21-28390-20/0)	(22-29169-00/0)
1199	4	72.50	Injection, DOHC		48/65					
Astra 1.2L 16V						09/00 → 01/05	23	AB5240 (MLS)	CB5240	EB5240
Z 12 XE								(30-028390-20)	(21-28390-21/0)	(22-29169-00/0)
1199	4	72.50	Injection, DOHC		55/75		→ Ch.36999999	→ Ch.36999999		
							AH5030 (MLS)	CH5030		
							(30-030366-00)	(21-30366-00/0)		
							Ch.46000001 →	Ch.46000001 →		
Astra 1.3L CDTI Diesel						04/05 →	24	AD5800 (MLS), 0.72mm	CD5820	ED5820
Z 13 DTH								(30-029762-00)		
1248	4	69.60	Direct Injection		66-74/ 90-101		AD5810 (MLS), 0.82mm, 1 Hole			
							(30-029763-00)			
							AD5820 (MLS), 0.92mm, 2 Holes			
							(30-029764-00)			
Astra 1.4L						09/91 → 09/93	25	BS260 (Fibre)	DS260	EK470
14 NV								(30-026329-10)	(21-26329-21/0)	(22-27194-05/0)
1389	4	77.60	Carburettor, SOHC		53-55/ 72-75					
Astra 1.4L						09/92 → 09/98	26	BS260 (Fibre)	DS261	ES260 [248]
Astra 1.4L Si						03/92 → 09/98		(30-026329-10)	(21-26329-22/0)	(22-27194-00/0)
Astra Convertible 1.4L Si						05/93 → 03/01				
14 SE	1389	4	77.60	Injection, SOHC	60/81					
C 14 SE	1389	4	77.60	MPI, SOHC	60/82					
Astra 1.4L						09/03 → 01/05	27	AH5030 (MLS)	CH5030	
Astra 1.4L Comfort						09/03 → 01/05		(30-030366-00)	(21-30366-00/0)	
Z 14 XEP	1364	4	73.40	Injection, DOHC	66/89					
Z 14 XEL	1364	4	77.00	Injection, DOHC	59/80					







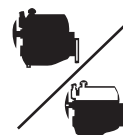



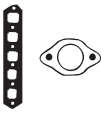

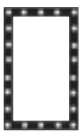

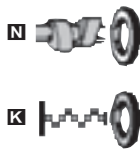

















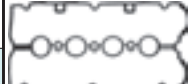















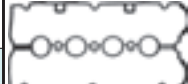















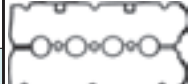











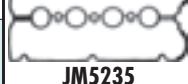









								
HBS003 ⊗ (22-29009B) M11x1.25x140mm (x10)	JC756 ■ (31-025820-20) JC282 ■ (31-024625-20) ⊙ JE120 (31-024767-00)	JN693 [128] (31-026198-10)	JJ385 [148] (50-026131-00)	PA565 (x8) (50-305900-50) HR342 ■ (24-30590-05/0)	NC006 ■ 35x48x7mm, MVQ (50-319161-00) NB700 ■ 31x50x8mm, FPM (50-306551-50) NB806 ■ 90x104x11mm, FPM (50-306552-00)	NB575 [2]■ NB807 [2]■		 AB5240  AD5800  AD5810  AD5820  BP820  BS260  JC281  JC282  JC756  JC823  JC824  JD5117  JE120  JE5024  JM5048  JN626  JN693 JN929
HBS003 ⊗ (22-29009B) M11x1.25x140mm (x10)	JC756 ■ (31-025820-20) JC282 ■ (31-024625-20)	JN693 [128] (31-026198-10)	JJ385 [148] (50-026131-00)	PA565 (x8) (50-305900-50) HR342 ■ (24-30590-05/0)	NC006 ■ 35x48x7mm, MVQ (50-319161-00) NB700 ■ 31x50x8mm, FPM (50-306551-50) NB806 ■ 90x104x11mm, FPM (50-306552-00)	NB575 [2]■ NB807 [2]■		
	JD5904 ■ (x4) (50-030368-00) (FPM)							
HBS252 ⊙ (22-29014B) M8x1.25x119mm (x12)	JD5904 ■ (x4) (50-030368-00) (FPM)	JM5071 (50-029232-00)	JH5036 (31-029169-00)	HR5048 ■ (24-31938-60/0)	NA5108 ■ 42x55x7mm, FPM (50-319392-00) NB698 ■ 80x98x10mm, FPM (50-319273-00)	JR5030 [11]		
HBS252 ⊙ (22-29014B) M8x1.25x119mm (x12)	JE5024 ■ (31-029170-00)	JM5048 (50-029167-00)	JH5036 (31-029169-00)	HR5048 ■ (24-31938-60/0)	NA5108 ■ 42x55x7mm, FPM (50-319392-00) NB698 ■ 80x98x10mm, FPM (50-319273-00)	JR5030 [11]		
HBS252 ⊙ (22-29014B) M8x1.25x119mm (x12)	JD5117 ■ (x4) (50-029186-00) →Ch.36999999 JD5904 ■ (x4) (50-030368-00) (FPM) Ch.46000001→ JE5024 ■ (31-029170-00)	JM5048 (50-029167-00) →Ch.16001502 JM5071 (50-029232-00) Ch.16001503→	JH5036 (31-029169-00)	HR5048 ■ (24-31938-60/0)	NA5108 ■ 42x55x7mm, FPM (50-319392-00) NB698 ■ 80x98x10mm, FPM (50-319273-00)	JR5030 [11]		
HBS353 ⊗ (22-17025B) M10x1.25x119mm (x10)	JD5413 ■ (31-030027-00) (MLS)	JM5259 (31-030023-00)	HR397 [57] 34-000410-00	HR5088 ■ (24-31952-10/0)	NA5223 ■ 40x52x7mm, FPM (50-319520-00) NA5230 ■ 78x100x9mm, PTFE (50-319522-00)			
HBS002 ⊙ (22-29098B) M10x1.25x140mm (x10)	JC824 ■ (31-026334-00) JC281 ■ (31-024312-10) ⊙ JE120 (31-024767-00)	JN626 (31-026099-10)	JH5005 [116] (31-027194-00) JJ120	PA565 (x8) (50-305900-50) HR342 ■ (24-30590-05/0)	NC006 ■ 35x48x7mm, MVQ (50-319161-00) NB697 ■ 26x42x8mm, FPM (50-306704-00) NB698 ■ 80x98x10mm, FPM (50-319273-00)	NB575 [2]■		
HBS002 ⊙ (22-29098B) M10x1.25x140mm (x10)	JC823 ■ (31-027191-10) JC281 ■ (31-024312-10)	JN929 (50-027192-10)	JH5005 [116] (31-027194-00) JJ120	PA565 (x8) (50-305900-50) HR342 ■ (24-30590-05/0)	NC006 ■ 35x48x7mm, MVQ (50-319161-00) NB697 ■ 26x42x8mm, FPM (50-306704-00) NB698 ■ 80x98x10mm, FPM (50-319273-00)	NB575 [2]■		
HBS252 ⊙ (22-29014B) M8x1.25x119mm (x12)	JD5904 ■ (x4) (50-030368-00) (FPM) JE5024 ■ (31-029170-00)	JM5071 (50-029232-00)	JH5036 (31-029169-00)	HR5048 ■ (24-31938-60/0)	NA5108 ■ 42x55x7mm, FPM (50-319392-00) NB698 ■ 80x98x10mm, FPM (50-319273-00)	JR5030 [11]		



KW/PS



Astra 1.4L 16V		02/98 → 01/05			28	AB5360 (MLS) (30-029200-00) Z14XE AY210 (Fibre) (30-027985-00) X14XE	CB5360 (21-29200-20/0) Z14XE CY211 (21-27985-22/0) X14XE	EB5360 (22-27665-02/0) → Eng.02M25253 → Eng.20U75999 Z14XE EY230 (22-27665-01/0) X14XE EB5541 [8] (22-27665-03/0) Eng.02M25254 → Eng.20U76000 → Z14XE
X 14 XE/Z 14 XE	1389	4	77.60	Injection, DOHC	66/89			
Astra 1.4L i		09/91 → 01/99			29	BS260 (Fibre) (30-026329-10)	DS260 (21-26329-21/0)	EK470 (22-27194-05/0)
C 14 NZ	1389	4	77.60	SPi, SOHC	44/60			
Astra 1.4L i		01/98 → 01/05			30	BS260 (Fibre) (30-026329-10)	DS260 (21-26329-21/0) → Eng.02DV7851 → Eng.19489817 DS261 (21-26329-22/0) Eng.02DV7851 → Eng.19489818 →	ES260 [248] (22-27194-00/0)
X 14 NZ	1389	4	77.60	SPi, DOHC	44/60			
Astra 1.4L i 16V		01/96 → 01/98			31	AY210 (Fibre) (30-027985-00)	CY210 (21-27985-21/0)	EY230 (22-27665-01/0)
X 14 XE	1389	4	77.60	Injection, DOHC	66/89			
Astra 1.4L i 16V		02/96 → 09/98			32	AY210 (Fibre) (30-027985-00)	CY210 (21-27985-21/0) → 01/98 CY211 (21-27985-22/0) 02/98 →	EY230 (22-27665-01/0)
X 14 XE	1389	4	77.60	Injection, DOHC	66/89			
Astra 1.6L		09/00 → 01/05			33	AE5920 (Steel) (30-029996-00)	CE5920 (21-29996-20/0)	EB5541 [8] (22-27665-03/0)
Astra Van 1.6L		09/00 → 04/05						
Z 16 SE	1598	4	79.00	Injection, SOHC	62/84			
Astra 1.6L		12/02 → 01/05			34	AE5930 (MLS) (30-029999-00)	CE5930 (21-29999-20/0)	
Astra Convertible 1.6L		01/03 → 10/05						
Astra Coupe 1.6L 16V		03/00 → 05/05						
Z 16 XEP	1598	4	79.00	Injection, DOHC	74-77/ 101- 105			







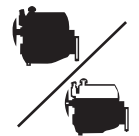



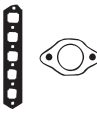



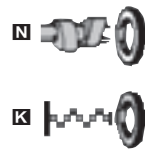











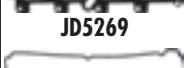

















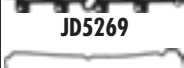

















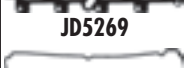

















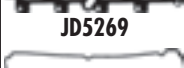

















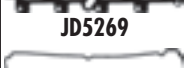

















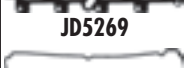

















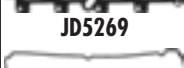

















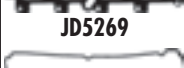















								
HBS055 Ⓢ (22-29012B) M10x1.25x153mm (x10)	JD5147 ■ (31-029203-00) JD5149 ■□ (31-029207-00) JD444 ■ (31-027878-00) X14XE JD5148 ■ (31-029204-00) Z14XE	JM5059 (50-029202-00) Z14XE	JJ575 [148] (50-027665-00)	HR791 ■ 24-30614-76/0	■ NC006 (x2) 35x48x7mm, MVQ (50-319161-00) ■ NB697 26x42x8mm, FPM (50-306704-00) ■ NB698 80x98x10mm, FPM (50-319273-00)			 AB5360  AE5920  AE5930  AY210  BS260  JC281  JC824  JD444  JD445  JD5147  JD5148  JD5149  JD5269  JD5398  JD5399  JD5400  JD5401  JM5059  JM5235  JN626  JN929  JP008
HBS002 Ⓢ (22-29098B) M10x1.25x140mm (x10)	JC824 ■ (31-026334-00) JC281 ■ (31-024312-10)	JN626 (31-026099-10)	JH5005 [116] (31-027194-00) JJ120	PA565 (x8) (50-305900-50) HR342 ■ (24-30590-05/0)	■ NC006 35x48x7mm, MVQ (50-319161-00) ■ NB697 26x42x8mm, FPM (50-306704-00) ■ NB698 80x98x10mm, FPM (50-319273-00)	NB575 [2]■		 JC824  JD444  JD445  JD5147  JD5148  JD5149  JD5269  JD5398  JD5399  JD5400  JD5401  JM5059  JM5235  JN626  JN929  JP008
HBS002 Ⓢ (22-29098B) M10x1.25x140mm (x10)	JC824 ■ (31-026334-00) JC281 ■ (31-024312-10)	JN626 (31-026099-10) →Eng.02DV7850 →Eng.19489817 JN929 (50-027192-10) Eng.02DV7850→ Eng.19489818→	JH5005 [116] (31-027194-00)	HR342 ■ (24-30590-05/0)	■ NC006 35x48x7mm, MVQ (50-319161-00) ■ NB697 26x42x8mm, FPM (50-306704-00) ■ NB698 80x98x10mm, FPM (50-319273-00)	NB575 [2]■		 JC824  JD444  JD445  JD5147  JD5148  JD5149  JD5269  JD5398  JD5399  JD5400  JD5401  JM5059  JM5235  JN626  JN929  JP008
HBS055 Ⓢ (22-29012B) M10x1.25x153mm (x10)	JD5269 ■ (31-027984-00) JD445 ■□ (31-027881-00) JD444 ■ (31-027878-00)	JP009 ■ (50-027983-00) JP008 ■ (50-027982-00)	JJ575 [148] (50-027665-00)	HR791 ■ 24-30614-76/0	■ NC006 (x2) 35x48x7mm, MVQ (50-319161-00) ■ NB697 26x42x8mm, FPM (50-306704-00) ■ NB698 80x98x10mm, FPM (50-319273-00)			 JD5149  JD5269  JD5398  JD5399  JD5400  JD5401  JM5059  JM5235  JN626  JN929  JP008
HBS055 Ⓢ (22-29012B) M10x1.25x153mm (x10)	JD5269 ■ (31-027984-00) →01/98 JD445 ■□ (31-027881-00) →01/98 JD5147 ■ (31-029203-00) 02/98→ JD5149 ■□ (31-029207-00) 02/98→ JD444 ■ (31-027878-00)	JP009 ■ (50-027983-00) →01/98 JP008 ■ (50-027982-00) →01/98 JM5059 (50-029202-00) 02/98→	JJ575 [148] (50-027665-00)	HR791 ■ 24-30614-76/0	■ NC006 (x2) 35x48x7mm, MVQ (50-319161-00) ■ NB697 26x42x8mm, FPM (50-306704-00) ■ NB698 80x98x10mm, FPM (50-319273-00)			 JM5059  JM5235  JN626  JN929  JP008
HBS002 Ⓢ (22-29098B) M10x1.25x140mm (x10)	JD5398 ■ (31-029997-00) JD5399 ■ (31-029998-00)	JN929 (50-027192-10)		HR342 ■ (24-30590-05/0)	■ NC006 (x2) 35x48x7mm, MVQ (50-319161-00) ■ NB697 26x42x8mm, FPM (50-306704-00) ■ NB698 80x98x10mm, FPM (50-319273-00)			 JM5059  JM5235  JN626  JN929  JP008
HBS055 Ⓢ (22-29012B) M10x1.25x153mm (x10)	JD5400 ■ (31-030002-00) JD5401 ■ (31-030004-00)	JM5235 (50-029985-00)		HR5087 ■ (24-31951-90/0)	■ NC006 (x2) 35x48x7mm, MVQ (50-319161-00) ■ NA5174 31.5x42x7mm, FPM (50-319469-00) ■ NB698 80x98x10mm, FPM (50-319273-00)			 JM5059  JM5235  JN626  JN929  JP008

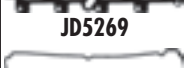

KW/PS



Astra 1.6L 02/98 → 09/00 35						BP800 (Fibre) (30-025706-20)	DP806 (21-25706-30/0)	ES260 [211] (22-27194-00/0) EY230 [210] (22-27665-01/0)
Astra 1.6L i 08/96 → 01/05								
X 16 SZR	1598	4	79.00	SPi, SOHC	55/75			
Astra 1.6L 16V 02/98 → 01/05 36						AB5540 (MLS) (30-029209-00) Z16XE AY220 (Fibre) X16XEL	CB5540 (21-29209-20/0) Z16XE DY232 (21-27986-25/0) X16XEL	EY230 (22-27665-01/0) → Eng.02MB4997 → Eng.20R22448 EB5541 [8] (22-27665-03/0) Eng.02MB4998 → Eng.20R22449 →
Z 16 XE	1598	4	79.00	MPi, DOHC	74/100			
X 16 XEL	1598	4	79.00	Injection, DOHC	74/78/ 100/ 106			
Astra 1.6L CNG 03/03 → 07/04 37						AB5540 (MLS) (30-029209-00)	CB5540 (21-29209-20/0)	
Z 16 YNG								
Z 16 YNG	1598	4	79.00	Injection, DOHC	69-74/ 94-101			
Astra 1.6L i 10/91 → 08/94 38						BP800 (Fibre) (30-025706-20)	DP802 (21-25706-25/0)	EK484 [129] (22-27194-01/0)
C 16 NZ								
C 16 NZ	1598	4	79.00	SPi, SOHC	55/75			
Astra 1.6L i 02/93 → 07/96 39						BP800 (Fibre) (30-025706-20)	DP802 (21-25706-25/0)	ES260 [248] (22-27194-00/0)
Astra Convertible 1.6L i 03/93 → 08/96								
X 16 SZ	1598	4	79.00	SPi, SOHC	52/71			
Astra 1.6L i 09/91 → 01/98 40						BP800 (Fibre) (30-025706-20)	DP802 (21-25706-25/0)	EK484 [129] (22-27194-01/0) ES260 [248] (22-27194-00/0)
C 16 NZ/X 16 SZR								
C 16 NZ/X 16 SZR	1598	4	79.00	SPi, SOHC	55/75			
Astra 1.6L i 16V 01/98 → 01/05 41						AY220 (Fibre)	DY232 (21-27986-25/0)	EY230 (22-27665-01/0)
X 16 XEL								
X 16 XEL	1598	4	79.00	Injection, DOHC	74/78/ 100/ 106			
Astra 1.6L i 16V 08/94 → 09/98 42						AY220 (Fibre)	CY221 (21-27986-22/0)	EY230 (22-27665-01/0)
X 16 XEL								
X 16 XEL	1598	4	79.00	Injection, DOHC	74/78/ 100/ 106			
Astra 1.6L Si 03/92 → 12/94 43						BP800 (Fibre) (30-025706-20)	DP803	EK484 [129] (22-27194-01/0)
C 16 SE								
C 16 SE	1598	4	79.00	MPi, SOHC	74/100			











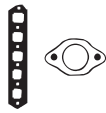

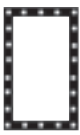

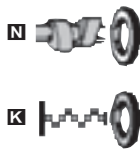



















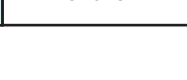



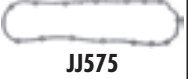















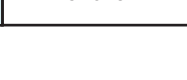



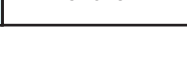

								
HBS002 Ⓢ (22-29098B) M10x1.25x140mm (x10)	JC824 ■ (31-026334-00) JC281 ■ (31-024312-10)	JN929 (50-027192-10)	JH5005 [211] (31-027194-00) JJ120 [211] JJ575 [210] (50-027665-00)	PA565 (x8) (50-305900-50) HR342 ■ (24-305900-05/0)	NC006 ■ 35x48x7mm, MVQ (50-319161-00) NB697 ■ 26x42x8mm, FPM (50-306704-00) NB698 ■ 80x98x10mm, FPM (50-319273-00)			 AB5540  AY220  BP800  JC281  JC823  JC824  JD444  JD5147  JD5148  JD5229  JD5269  JM5059  JN626  JN929  JP008  JP009  JH5005  JJ120  JJ575
HBS055 Ⓢ (22-29012B) M10x1.25x153mm (x10)	JD5147 ■ (31-029203-00) JD444 ■ (31-027878-00) X16XEL JD5148 ■ (31-029204-00) Z16XE	JM5059 (50-029202-00)	JJ575 [148] (50-027665-00) → Eng. 02MB4997 → Eng. 20R22448	HR791 ■ 24-30614-76/0	NC006 ■ (x2) 35x48x7mm, MVQ (50-319161-00) NB697 ■ 26x42x8mm, FPM (50-306704-00) NB698 ■ 80x98x10mm, FPM (50-319273-00)			 AB5540  AY220  BP800  JC281  JC823  JC824  JD444  JD5147  JD5148  JD5229  JD5269  JM5059  JN626  JN929  JP008  JP009  JH5005  JJ120  JJ575
HBS055 Ⓢ (22-29012B) M10x1.25x153mm (x10)	JD5147 ■ (31-029203-00) JD5148 ■ (31-029204-00)	JM5059 (50-029202-00)		HR280 ■ 24-30614-75/0	NC006 ■ (x2) 35x48x7mm, MVQ (50-319161-00) NB697 ■ 26x42x8mm, FPM (50-306704-00) NB698 ■ 80x98x10mm, FPM (50-319273-00)			 AB5540  AY220  BP800  JC281  JC823  JC824  JD444  JD5147  JD5148  JD5229  JD5269  JM5059  JN626  JN929  JP008  JP009  JH5005  JJ120  JJ575
HBS002 Ⓢ (22-29098B) M10x1.25x140mm (x10)	JC824 ■ (31-026334-00) JC281 ■ (31-024312-10)	JN626 (31-026099-10)	JH5005 (x2) [116] (31-027194-00) JJ120 (x2)	PA565 (x8) (50-305900-50) HR342 ■ (24-305900-05/0)	NC006 ■ 35x48x7mm, MVQ (50-319161-00) NB697 ■ 26x42x8mm, FPM (50-306704-00) NB698 ■ 80x98x10mm, FPM (50-319273-00)	NB575 [2]■		 AB5540  AY220  BP800  JC281  JC823  JC824  JD444  JD5147  JD5148  JD5229  JD5269  JM5059  JN626  JN929  JP008  JP009  JH5005  JJ120  JJ575
HBS002 Ⓢ (22-29098B) M10x1.25x140mm (x10)	JC824 ■ (31-026334-00) JC281 ■ (31-024312-10)	JN626 (31-026099-10)	JH5005 [116] (31-027194-00) JJ120	HR342 ■ (24-305900-05/0)	NC006 ■ 35x48x7mm, MVQ (50-319161-00) NB697 ■ 26x42x8mm, FPM (50-306704-00) NB698 ■ 80x98x10mm, FPM (50-319273-00)	NB575 [2]■		 AB5540  AY220  BP800  JC281  JC823  JC824  JD444  JD5147  JD5148  JD5229  JD5269  JM5059  JN626  JN929  JP008  JP009  JH5005  JJ120  JJ575
HBS002 Ⓢ (22-29098B) M10x1.25x140mm (x10)	JC824 ■ (31-026334-00) JC281 ■ (31-024312-10)	JN626 (31-026099-10)	JH5005 (x2) [116] (31-027194-00) JJ120 (x2)	PA565 (x8) (50-305900-50) HR342 ■ (24-305900-05/0)	NC006 ■ 35x48x7mm, MVQ (50-319161-00) NB697 ■ 26x42x8mm, FPM (50-306704-00) NB698 ■ 80x98x10mm, FPM (50-319273-00)	NB575 [2]■		 AB5540  AY220  BP800  JC281  JC823  JC824  JD444  JD5147  JD5148  JD5229  JD5269  JM5059  JN626  JN929  JP008  JP009  JH5005  JJ120  JJ575
HBS055 Ⓢ (22-29012B) M10x1.25x153mm (x10)	JD5147 ■ (31-029203-00) JD444 ■ (31-027878-00)	JM5059 (50-029202-00)	JJ575 [148] (50-027665-00)	HR791 ■ 24-30614-76/0	NC006 ■ (x2) 35x48x7mm, MVQ (50-319161-00) NB697 ■ 26x42x8mm, FPM (50-306704-00) NB698 ■ 80x98x10mm, FPM (50-319273-00)			 AB5540  AY220  BP800  JC281  JC823  JC824  JD444  JD5147  JD5148  JD5229  JD5269  JM5059  JN626  JN929  JP008  JP009  JH5005  JJ120  JJ575
HBS055 Ⓢ (22-29012B) M10x1.25x153mm (x10)	JD5269 ■ (31-027984-00) JD5229 ■ ■ (31-028463-00) JD444 ■ (31-027878-00)	JP009 ■ (50-027983-00) JP008 ■ (50-027982-00)	JJ575 [148] (50-027665-00)	HR791 ■ 24-30614-76/0	NC006 ■ (x2) 35x48x7mm, MVQ (50-319161-00) NB697 ■ 26x42x8mm, FPM (50-306704-00) NB698 ■ 80x98x10mm, FPM (50-319273-00)			 AB5540  AY220  BP800  JC281  JC823  JC824  JD444  JD5147  JD5148  JD5229  JD5269  JM5059  JN626  JN929  JP008  JP009  JH5005  JJ120  JJ575
HBS002 Ⓢ (22-29098B) M10x1.25x140mm (x10)	JC823 ■ (31-027191-10) JC281 ■ (31-024312-10)	JN929 (50-027192-10)	JH5005 [116] (31-027194-00) JJ120	PA565 (x8) (50-305900-50) HR342 ■ (24-305900-05/0)	NC006 ■ 35x48x7mm, MVQ (50-319161-00) NB697 ■ 26x42x8mm, FPM (50-306704-00) NB698 ■ 80x98x10mm, FPM (50-319273-00)			 AB5540  AY220  BP800  JC281  JC823  JC824  JD444  JD5147  JD5148  JD5229  JD5269  JM5059  JN626  JN929  JP008  JP009  JH5005  JJ120  JJ575



KW/PS

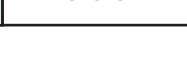

Astra Convertible 1.6L 16V		03/01 → 10/05		44		AB5540 (MLS) (30-029209-00)	CB5540 (21-29209-20/0)	EB5541 [8] (22-27665-03/0)
Z 16 XE	1598	4	79.00	MPI, DOHC	74/100			
Astra Van 1.6L		01/99 → 09/00		45		BP800 (Fibre) (30-025706-20)	DP806 (21-25706-30/0)	ES260 [211] (22-27194-00/0) EY230 [210] (22-27665-01/0)
X 16 SZR	1598	4	79.00	SPi, SOHC	55/75			
Astra 1.7L CDTI Diesel		04/03 → 01/05		46		AE5520 (MLS), 1.45mm, 1 Hole (30-029904-00) AE5530 (MLS), 1.50mm, 2 Holes (30-029905-00) AE5540 (MLS), 1.55mm, 3 Notches (30-029906-00)	CE5522▲ (21-29904-22/0)	EE5520 (22-29904-00/0)
Z 17 DTL	1686	4	79.00	CDTI, DOHC	59/80			
Astra 1.7L CDTI Diesel		03/04 →		47		AE5520 (MLS), 1.45mm, 1 Hole (30-029904-00) AE5530 (MLS), 1.50mm, 2 Holes (30-029905-00) AE5540 (MLS), 1.55mm, 3 Notches (30-029906-00)	CE5523▲ (21-29904-23/0)	EE5520 (22-29904-00/0)
Z 17 DTH	1686	4	79.00	Direct Injection, DOHC	74/100			
Astra 1.7L D Diesel		07/92 → 01/99		48		BY330 (Fibre), 1.30mm (30-027492-10) BY340 (Fibre), 1.40mm, 1 Notch (30-027493-10) BY350 (Fibre), 1.50mm, 2 Notches (30-027494-10)	DL011▲ (21-26198-20/0)	EK485 (22-25011-04/0)
17 DR	1699	4	82.50	SOHC	42-44/ 57-60			
Astra 1.7L D Diesel		12/91 → 09/92		49		BY330 (Fibre), 1.30mm (30-027492-10) BY340 (Fibre), 1.40mm, 1 Notch (30-027493-10) BY350 (Fibre), 1.50mm, 2 Notches (30-027494-10)	DL011▲ (21-26198-20/0)	EK485 (22-25011-04/0)
17 D	1699	4	82.50	SOHC	42/57			
Astra 1.7L D Diesel		07/92 → 01/98		50		BY330 (Fibre), 1.30mm (30-027492-10) BY340 (Fibre), 1.40mm, 1 Notch (30-027493-10) BY350 (Fibre), 1.50mm, 2 Notches (30-027494-10)	DL011▲ (21-26198-20/0)	EK485 (22-25011-04/0)
17 DR	1699	4	82.50	SOHC	42-44/ 57-60			
Astra 1.7L DTI 16V Diesel		02/00 → 01/05		51		AE5520 (MLS), 1.45mm, 1 Hole (30-029904-00) AE5530 (MLS), 1.50mm, 2 Holes (30-029905-00) AE5540 (MLS), 1.55mm, 3 Notches (30-029906-00)	CE5521▲ (21-29904-21/0)	EE5520 (22-29904-00/0)
Y 17 DT	1686	4	79.00	Direct Injection, DOHC	55/75			

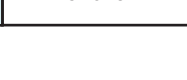
								
HBS055 ® (22-29012B) M10x1.25x153mm (x10)	JD5147 ■ (31-029203-00) JD5148 ■ (31-029204-00)	JM5059 (50-029202-00)		HR791 ■ 24-30614-76/0	NC006 ■ (x2) 35x48x7mm, MVQ (50-319161-00) NB697 ■ 26x42x8mm, FPM (50-306704-00) NB698 ■ 80x98x10mm, FPM (50-319273-00)			 AB5540  AE5520, AE5530, AE5540  BP800  BY330, BY340, BY350  JC281  JC436  JC437  JC824  JD474  JD5147  JD5148  JD5329  JD5330  JD5331  JD5332  JD5334  JD5336  JE119  JM5059  JN693
HBS002 ® (22-29098B) M10x1.25x140mm (x10)	JC824 ■ (31-026334-00) JC281 ■ (31-024312-10)	JN929 (50-027192-10)	JH5005 [211] (31-027194-00) JJ120 JJ575 [210] (50-027665-00)	PA565 (x8) (50-305900-50) HR342 ■ (24-305900-05/0)	NC006 ■ 35x48x7mm, MVQ (50-319161-00) NB697 ■ 26x42x8mm, FPM (50-306704-00) NB698 ■ 80x98x10mm, FPM (50-319273-00)			 JN929  JH5005  JJ120  JJ200  JJ575
HBS036 ® (22-29001B) M12x1.5x102mm (x10)	JD5334 ■ (31-029914-00) JD5330 ■ (31-029910-00)	JM5198 (50-029908-00)		HR791 ■ 24-30614-76/0	NB884 38x50x5.5mm, FPM (50-319010-00) NJ449 ■ 40x52x6mm, NBR (50-319266-00) NK103 ■ 87x100x8.5mm, FPM			 JC436  JC437  JC824  JD474  JD5147
HBS036 ® (22-29001B) M12x1.5x102mm (x10)	JD5334 ■ (31-029914-00) JD5331 ■ (x2) (31-029911-00)	JM5198 (50-029908-00)		HR791 ■ 24-30614-76/0	NB884 38x50x5.5mm, FPM (50-319010-00) NJ449 ■ 40x52x6mm, NBR (50-319266-00) NK103 ■ 87x100x8.5mm, FPM			 JD474  JD5147  JD5148  JD5329  JD5330  JD5331  JD5332  JD5334  JD5336  JE119  JM5059
HBS074 ® (22-29100B) M11x1.25x154mm (x10)	JD474 ■ JC437 ■ (31-024854-10) ☉ JE119 (31-024520-00)	JN693 [128] (31-026198-10)	JJ200 (31-025011-00)	HR343 ■ (24-30602-50/0)	NC006 ■ 35x48x7mm, MVQ (50-319161-00) NB734 ■ 35x50x8mm, FPM NB806 ■ 90x104x11mm, FPM (50-306552-00)	NB575 [2]■		 JD5147  JD5148  JD5329  JD5330  JD5331  JD5332  JD5334
HBS074 ® (22-29100B) M11x1.25x154mm (x10)	JD474 ■ JC437 ■ (31-024854-10) ☉ JE119 (31-024520-00)	JN693 [128] (31-026198-10)	JJ200 (31-025011-00)	HR343 ■ (24-30602-50/0)	NC006 ■ 35x48x7mm, MVQ (50-319161-00) NB734 ■ 35x50x8mm, FPM NB806 ■ 90x104x11mm, FPM (50-306552-00)	NB575 [2]■		 JD5330  JD5331  JD5332  JD5334  JD5336  JE119  JM5059  JN693
HBS036 ® (22-29001B) M12x1.5x102mm (x10)	JD5332 ■ (31-029912-00) →Eng.721439 JD5333 ■ (31-029913-00) Eng.721439 → JD5336 ■ ■ (31-029916-00) Eng.721439 → JD5329 ■ (31-029909-00)	JM5197 (50-029907-00)		HR791 ■ 24-30614-76/0	NB884 38x50x5.5mm, FPM (50-319010-00) NJ449 ■ 40x52x6mm, NBR (50-319266-00) NK103 ■ 87x100x8.5mm, FPM			 JM5059  JN693







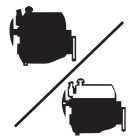



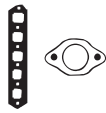

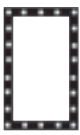

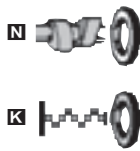

































































OPEL



KW/PS



Astra 1.7L TD Diesel						08/94 → 08/00	52	AY160 (MLS), 1.30mm (30-028498-00)	DL012▲ (21-27879-20/0)	EK486 [6] (22-28498-00/0)
Astra Van 1.7L TD Diesel						01/99 → 04/05		AY170 (MLS), 1.40mm, 1 Notch (30-028499-00)		
Astra 1.7L TDS Diesel						12/91 → 09/98	53	AB5010 (MLS), 1.40mm (30-029163-00)	CY811▲■ (21-27776-22/0)	FY811 ▲ (20-27776-02/0)
X 17 DTL	1699	4	82.50	Direct Injection, SOHC	50/68		AY180 (MLS), 1.50mm, 2 Notches (30-028500-00)			
17 DT (TC4EE1)/ X 17 DT (TC4EE1)	1686	4	79.00	SOHC	60/81		AB5020 (MLS), 1.45mm, 1 Hole (30-029164-00)			
							AB5030 (MLS), 1.50mm, 2 Holes (30-029165-00)			
Astra 1.8L 16V						02/98 → 09/00	54	AC5460 (MLS) (30-028674-00)	CC5460 (21-28674-20/0)	
Astra Coupe 1.8L 16V						03/00 → 10/00				
X 18 XE1	1796	4	80.50	MPi, DOHC	85/115					
Astra 1.8L i 16V						06/93 → 01/98	55	BY240 (Fibre) (30-027682-00)	DY241 (21-27682-20/0)	EC130 (22-28793-00/0)
C 18 XE	1796	4	81.60	Injection, DOHC	92/125					
Astra 1.8L i 16V						07/94 → 09/98	56	BY240 (Fibre) (30-027682-00)	DY241 (21-27682-20/0)	EC130 (22-28793-00/0)
Astra Convertible 1.8L i 16V						11/94 → 03/01				HC5007 [212] (22-28386-00/0)
C 18 XEL	1796	4	81.60	Injection, DOHC	85/115					
X 18 XE	1796	4	81.60	MPi, DOHC	85/115					
Astra 1.9L CDTI Diesel						09/04 →	57	AD5840 (MLS), 0.82mm, 0 Holes (30-029766-00)	CD5840▲ (21-29766-20/0)	EE5181 (22-29832-01/0)
Z 19 DTH	1910	4	82.00	Direct Injection	88-110/ 120- 150		AD5850 (MLS), 0.92mm, 1 Hole (30-029767-00)			
							AD5860 (MLS), 1.02mm, 2 Holes (30-029768-00)			
Astra 1.9L CDTI Diesel						09/05 →	58	AA5560 (MLS), 0.82mm, 0 Hole (30-029094-10)	CG7390▲ (21-30144-00/0)	EE5181 (22-29832-01/0)
Z 19 DT	1910	4	82.00	Direct Injection	74-88/ 100- 120		AA5570 (MLS), 0.92mm, 1 Hole (30-029094-10)			
							AA5580 (MLS), 1.02mm, 2 Holes (30-029095-10)			
Astra 1.9L CDTI 16V Diesel						04/04 →	59	AD5840 (MLS), 0.82mm, 0 Holes (30-029766-00)	CD5840▲ (21-29766-20/0)	EE5181 (22-29832-01/0)
Z 19 DTJ	1910	4	82.00	Direct Injection, DOHC	88/120		AD5850 (MLS), 0.92mm, 1 Hole (30-029767-00)			
Z 19 DTH	1910	4	82.00	Direct Injection	88-110/ 120- 150		AD5860 (MLS), 1.02mm, 2 Holes (30-029768-00)			
Astra 1.9L CDTI 16V Diesel						08/04 →	60	AA5570 (MLS), 0.92mm, 1 Hole (30-029094-10)		EE5181 (22-29832-01/0)
Z 19 DTJ	1910	4	82.00	Direct Injection, DOHC	88/120		AA5580 (MLS), 1.02mm, 2 Holes (30-029095-10)			
Astra CDTI Diesel						01/06 →	61	AA5560 (MLS), 0.82mm, 0 Hole (30-029094-10)	CG7390▲ (21-30144-00/0)	EE5181 (22-29832-01/0)
Z 19 DTL	1910	4	82.00	Direct Injection	74/100		AA5570 (MLS), 0.92mm, 1 Hole (30-029094-10)			
							AA5580 (MLS), 1.02mm, 2 Holes (30-029095-10)			

								
HBS074  (22-29100B) M11x1.25x154mm (x10)	JD474  JC437  (31-024854-10)	JP018 (50-027879-00)	JJ574 [6] (50-027842-00)	HR343  (24-30602-50/0)	 NC006  35x48x7mm, MVQ (50-319161-00)  NB734  35x50x8mm, FPM  NB806  90x104x11mm, FPM (50-306552-00)			AA5570, AA5580 AB5010, AB5020, AB5030 AC5460 AY160, AY170, AY180 BY240 JC437 JD303 JD304 JD451 JD468 JD474 JD5196 JD5197 JD5376 JE120 JM5092 JN777 JP016 JP16 JP18 JJ574 JJ615 JJ616 JJ617
HBS036  (22-29001B) M12x1.5x102mm (x10)	JD303  JD5914  (31-027778-00) JD304   JE5029 (31-027779-00)	JN777 (50-027776-00)		PA658 (x8) (50-319265-00)	 NJ449 40x52x6mm, NBR (50-319266-00)  NC004 (50-319268-00)  NJ449 40x52x6mm, NBR (50-319266-00)  NK103 87x100x8.5mm, FPM			AA5570, AA5580 AB5010, AB5020, AB5030 AC5460 AY160, AY170, AY180 BY240 JC437 JD303 JD304 JD451 JD468 JD474 JD5196 JD5197 JD5376 JE120 JM5092 JN777 JP016 JP16 JP18 JJ574 JJ615 JJ616 JJ617
HBS055  (22-29012B) M10x1.25x153mm (x10)	JD5196  (31-029039-00) JD5197  (31-029040-00)	JM5092 (50-029087-00)		HR5048  (24-31938-60/0)	 NC006 (x2) 35x48x7mm, MVQ (50-319161-00)  NC065 30x40x7mm, FPM (50-306142-00)  NB698 80x98x10mm, FPM (50-319273-00)			AA5570, AA5580 AB5010, AB5020, AB5030 AC5460 AY160, AY170, AY180 BY240 JC437 JD303 JD304 JD451 JD468 JD474 JD5196 JD5197 JD5376 JE120 JM5092 JN777 JP016 JP16 JP18 JJ574 JJ615 JJ616 JJ617
HBS054  (22-29013B) M11x1.25x105mm (x10)	JD451  (31-027699-00) JD450  (31-027684-00)  JE120 (31-024767-00)	JP016 (50-027683-00)	JJ615 (31-028793-00)	HR791  24-30614-76/0	 NC006 (x2) 35x48x7mm, MVQ (50-319161-00)  NB700 31x50x8mm, FPM (50-306551-50)  NB806 90x104x11mm, FPM (50-306552-00)			AA5570, AA5580 AB5010, AB5020, AB5030 AC5460 AY160, AY170, AY180 BY240 JC437 JD303 JD304 JD451 JD468 JD474 JD5196 JD5197 JD5376 JE120 JM5092 JN777 JP016 JP16 JP18 JJ574 JJ615 JJ616 JJ617
HBS054  (22-29013B) M11x1.25x105mm (x10)	JD451  (31-027699-00) JD450  (31-027684-00)  JE120 (31-024767-00)	JP016 (50-027683-00)	JJ615 (31-028793-00) JJ616  [212] (31-028386-00) JJ617  [212] (31-028385-00)	HR791  24-30614-76/0	 NC006 (x2) 35x48x7mm, MVQ (50-319161-00)  NB700 31x50x8mm, FPM (50-306551-50)  NB806 90x104x11mm, FPM (50-306552-00)			AA5570, AA5580 AB5010, AB5020, AB5030 AC5460 AY160, AY170, AY180 BY240 JC437 JD303 JD304 JD451 JD468 JD474 JD5196 JD5197 JD5376 JE120 JM5092 JN777 JP016 JP16 JP18 JJ574 JJ615 JJ616 JJ617
HBS370  (22-17026B) M12x1.25x225mm (x10)	JD5376  (31-029969-00)	JM5204 (50-029935-00) JM7055 (Steel Elastomer)		HR363  HR5095 	 NA5053 30x42x7mm, FPM (50-319488-00)  NA5070 31x41x7mm, FPM (50-319524-00)	HL5031 [245] 		AA5570, AA5580 AB5010, AB5020, AB5030 AC5460 AY160, AY170, AY180 BY240 JC437 JD303 JD304 JD451 JD468 JD474 JD5196 JD5197 JD5376 JE120 JM5092 JM5204 JN777 JP016 JP16 JP18 JJ574 JJ615 JJ616 JJ617
HBS227  (22-17018B) M12x1.25x218mm (x10)	JD468  (31-028377-00) (MLS)	JM5204 (50-029935-00)		HR363 	 NA5053 30x42x7mm, FPM (50-319488-00)  NA5070 31x41x7mm, FPM (50-319524-00)	HL5031 [245] 		AA5570, AA5580 AB5010, AB5020, AB5030 AC5460 AY160, AY170, AY180 BY240 JC437 JD303 JD304 JD451 JD468 JD474 JD5196 JD5197 JD5376 JE120 JM5092 JM5204 JN777 JP016 JP16 JP18 JJ574 JJ615 JJ616 JJ617
HBS227  (22-17018B) M12x1.25x218mm (x10)	JD468  (31-028377-00) (MLS)	JM7055 (Steel Elastomer)		HR5095 	 NA5053 30x42x7mm, FPM (50-319488-00)  NA5070 31x41x7mm, FPM (50-319524-00)	HL5031 [245] 		AA5570, AA5580 AB5010, AB5020, AB5030 AC5460 AY160, AY170, AY180 BY240 JC437 JD303 JD304 JD451 JD468 JD474 JD5196 JD5197 JD5376 JE120 JM5092 JM5204 JN777 JP016 JP16 JP18 JJ574 JJ615 JJ616 JJ617
HBS227  (22-17018B) M12x1.25x218mm (x10)	JD468  (31-028377-00) (MLS)	JM7055 (Steel Elastomer)		HR5095 	 NA5053 30x42x7mm, FPM (50-319488-00)  NA5070 31x41x7mm, FPM (50-319524-00)	HL5031 [245] 		AA5570, AA5580 AB5010, AB5020, AB5030 AC5460 AY160, AY170, AY180 BY240 JC437 JD303 JD304 JD451 JD468 JD474 JD5196 JD5197 JD5376 JE120 JM5092 JM5204 JN777 JP016 JP16 JP18 JJ574 JJ615 JJ616 JJ617
HBS227  (22-17018B) M12x1.25x218mm (x10)	JD468  (31-028377-00) (MLS)	JM5204 (50-029935-00)		HR363 	 NA5053 30x42x7mm, FPM (50-319488-00)  NA5070 31x41x7mm, FPM (50-319524-00)	HL5031 [245] 		AA5570, AA5580 AB5010, AB5020, AB5030 AC5460 AY160, AY170, AY180 BY240 JC437 JD303 JD304 JD451 JD468 JD474 JD5196 JD5197 JD5376 JE120 JM5092 JM5204 JN777 JP016 JP16 JP18 JJ574 JJ615 JJ616 JJ617











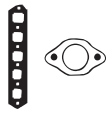

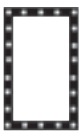

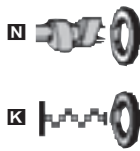





























































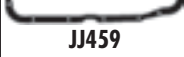











OPEL



KW/PS



Astra 2.0L Turbo						03/05 →	62			EG9570
Z 20 LEH	1998	4	86.00	Injection			177/240			
Astra 16V Turbo						11/02 → 10/05	63	AG9570 (MLS)	CG9570	EG9570
Astra 2.0L OPC						09/02 → 01/05		(30-030342-00)	(21-30342-00/0)	
Astra 2.0L Turbo						03/04 →				
Astra Convertible 2.0L OPC						03/02 → 10/05				
Astra Coupe 2.0L 16V Turbo						09/00 → 05/05				
Z 20 LEL	1998	4	86.00	Injection			125/170			
Z 20 LET	1998	4	86.00	Injection, DOHC			140- 147/ 190- 200			
Z 20 LER	1998	4	86.00	Injection, DOHC			147/200			
Astra 2.0L 16V						02/98 → 01/05	64	BY250 (Fibre)	DY250	HC5007 [212]
Astra 2.0L i 16V						02/95 → 09/98		(30-027987-10)	(21-27987-20/0)	(22-28386-00/0)
X 20 XEV	1998	4	86.00	Injection, DOHC			100/136			
Astra 2.0L 16V OPC						11/99 → 09/02	65	BY250 (Fibre)		HC5007
X 20 XER	1998	4	86.00	MPi, DOHC			118/160	(30-027987-10)		(22-28386-00/0)
Astra 2.0L DI Diesel						02/98 → 01/05	66	AB5671 (MLS), 1.30mm, 1 Notch	CB5670▲■	EB5670
Astra Van 2.0L DI Diesel						01/99 → 04/05		AB5681 (MLS), 1.40mm, 2 Notches	(21-29011-20/0)	(22-29011-00/0)
X 20 DTL	1995	4	84.00	Direct Injection			60/81			
Y 20 DTL	1995	4	84.00				60/81			
Astra 2.0L DTI 16V Diesel						08/99 → 01/05	67	AB5671 (MLS), 1.30mm, 1 Notch	CB5670▲■	EB5670
Astra 2.0L DTI 16V Diesel						08/99 → 01/05		AB5681 (MLS), 1.40mm, 2 Notches	(21-29011-20/0)	(22-29011-00/0)
X 20 DTH/Y 20 DTH	1995	4	84.00	Direct Injection			74/100		X20DTH CB5671▲■ (21-29011-21/0) Y20DTH	
Astra 2.0L GSI 16V						09/91 → 01/98	68	BS720 (Fibre)	DS720	ES720
Astra 2.0L i 16V						03/93 → 01/98		(30-026310-10)	(21-26310-22/0)	(22-27206-00/0)
C 20 XE	1998	4	86.00	MPi, DOHC			110/150			







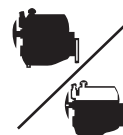



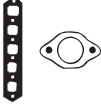

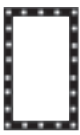

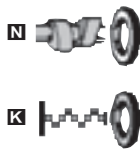













































































































								
HBS054  (22-29013B) M11x1.25x105mm (x10)	JD451  (31-027699-00) JD5903  (31-030367-00) (MLS)	JP016 (50-027683-00)	JJ616  (31-028386-00) JJ617  (31-028385-00)	HR791  24-30614-76/0	NC006  (x2) 35x48x7mm, MVQ (50-319161-00) NB700  31x50x8mm, FPM (50-306551-50) NB806  90x104x11mm, FPM (50-306552-00)			 BS720  BY250  JD430  JD451  JD455  JD5255  JD5256  JD5277  JD5347  JM5159  JM950  JP016  JH5057  JJ459  JJ616  JJ617
HBS054  (22-29013B) M11x1.25x105mm (x10)	JD451  (31-027699-00) JD5903  (31-030367-00) (MLS)	JP016 (50-027683-00)	JJ616  (31-028386-00) JJ617  (31-028385-00)	HR791  24-30614-76/0	NC006  (x2) 35x48x7mm, MVQ (50-319161-00) NB700  31x50x8mm, FPM (50-306551-50) NB806  90x104x11mm, FPM (50-306552-00)			
HBS054  (22-29013B) M11x1.25x105mm (x10)	JD451  (31-027699-00) JD450  (31-027684-00)	JP016 (50-027683-00)	JJ616  [212] (31-028386-00) JJ617  [212] (31-028385-00)	HR791  24-30614-76/0	NC006  (x2) 35x48x7mm, MVQ (50-319161-00) NB700  31x50x8mm, FPM (50-306551-50) NB806  90x104x11mm, FPM (50-306552-00)			
HBS054  (22-29013B) M11x1.25x105mm (x10)	JD450  (31-027684-00)	JP016 (50-027683-00)	JJ616  (31-028386-00) JJ617  (31-028385-00)	HR791  24-30614-76/0	NC006  (x2) 35x48x7mm, MVQ (50-319161-00) NB700  31x50x8mm, FPM (50-306551-50) NB806  90x104x11mm, FPM (50-306552-00)			
HBS298  (22-29016B) M12x1.50x235mm (x10)	JD5255  (31-029721-00) JD5347  (31-029942-00) JD5256  (31-029722-00)	JM5159 (50-029633-00)	JH5057 (31-029575-00)	HR791  24-30614-76/0	NA5069  55x68x8mm, FPM (50-319515-00) NA5209  99x114x11mm, FPM (50-319514-00)			 JH5057  JJ459  JJ616  JJ617
HBS298  (22-29016B) M12x1.50x235mm (x10)	JD5255  (31-029721-00) JD5277  (31-029723-00) Y20DTH JD5347  (31-029942-00) X20DTH JD5256  (31-029722-00)	JM5159 (50-029633-00)	JH5057 (31-029575-00)	HR791  24-30614-76/0	NA5069  55x68x8mm, FPM (50-319515-00) NA5209  99x114x11mm, FPM (50-319514-00)			 JJ459  JJ616  JJ617
HBS035  (22-29005B) M11x1.25x110mm (x10) →Eng.14003804 HBS054  (22-29013B) M11x1.25x105mm (x10) Eng.14003805→	JD455  (31-026335-10) JD430  (31-025888-00)	JM950 (50-026336-10)	JJ459 (x2) [148] (31-027206-00)	PA565 (x16) (50-305900-50) HR342  (x2) (24-305900-05/0)	NC006  (x2) 35x48x7mm, MVQ (50-319161-00) NB884  38x50x5.5mm, FPM (50-319010-00) NB806  90x104x11mm, FPM (50-306552-00)	NB575 [2]  NB807 [2] 		



KW/PS



Astra 2.0L i		09/91 → 01/98			69	BP820 (Fibre) (30-025819-10)	DP820 (21-25819-21/0)	EK482 (22-26131-01/0)
C 20 NE	1998	4	86.00	MPI, SOHC	85/115			
Astra 2.0L i		09/91 → 09/98			70	BP820 (Fibre) (30-025819-10)	DP820 (21-25819-21/0)	EK482 (22-26131-01/0)
Astra Convertible 2.0L i		03/93 → 10/94						
C 20 NE	1998	4	86.00	MPI, SOHC	85/115			
Astra 2.2L		09/00 → 03/04			71	AG9580 (MLS) (30-030344-00)	CG9580 (21-30344-00/0)	
Astra 16V		09/00 → 10/05						
Z 22 SE	2198	4	86.00	Injection, DOHC	108/147			
Astra 2.2L DTI Diesel		09/02 → 01/05			72	AB5671 (MLS), 1.30mm, 1 Notch AB5681 (MLS), 1.40mm, 2 Notches	CB5671 ▲■ (21-29011-21/0)	EB5670 (22-29011-00/0)
Astra Convertible 2.2L DTI Diesel		09/02 → 10/05						
Astra Coupe 2.2L DTI Diesel		09/02 → 05/05						
Y 22 DTR	2172	4	84.00	Direct Injection, SOHC	92/125			
Calibra Coupe 2.0L i		06/90 → 07/97			73	BP820 (Fibre) (30-025819-10)	DP820 (21-25819-21/0)	EK482 (22-26131-01/0)
Calibra Coupe 2.0L i 4x4		06/90 → 07/97						
C 20 NE	1998	4	86.00	MPI, SOHC	85/115			
Calibra Coupe 2.0L i 16V		06/90 → 02/94			74	BS720 (Fibre) (30-026310-10)	DS720 (21-26310-22/0)	ES720 (22-27206-00/0)
Calibra Coupe 2.0L i 16V 4x4		06/90 → 02/94						
C 20 XE	1998	4	86.00	MPI, DOHC	110/150			
Calibra Coupe 2.0L i 16V		02/94 → 07/97			75	BY250 (Fibre) (30-027987-10)	DY250 (21-27987-20/0)	EC130 (22-28793-00/0) HC5007 [212] (22-28386-00/0)
Calibra Coupe 2.0L i 16V 4x4		02/94 → 07/97						
X 20 XEV	1998	4	86.00	Injection, DOHC	100/136			
Calibra Coupe 2.0L i Turbo 4x4		03/92 → 07/97			76	BY260 (Fibre) (30-027427-00)	DY260 (21-27427-21/0)	ES720 (22-27206-00/0)
C 20 LET	1998	4	86.00	MPI, DOHC	150/204			







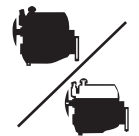



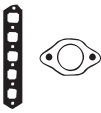

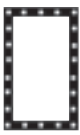

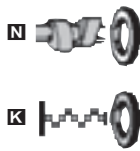





































































































































								
HBS003  (22-29009B) M11x1.25x140mm (x10) →12/96 HBS053  (22-29099B) M11x1.25x140mm (x10) 01/97→	JC756  (31-025820-20) JC282  (31-024625-20)  JE120 (31-024767-00)	JN693 [128] (31-026198-10)	JJ385 [148] (50-026131-00)	PA565 (x8) (50-305900-50) HR342  (24-305900-05/0)	 NC006  35x48x7mm, MVQ (50-319161-00)  NB700  31x50x8mm, FPM (50-306551-50)  NB806  90x104x11mm, FPM (50-306552-00)	NB575 [2]  NB807 [2] 	 BP820  BS720  BY250  BY260  JC282  JC756  JD430  JD451  JD455  JD456  JD5255  JD5256  JD5277  JE120  JM5159  JM950  JN693  JP016  JH5057  JJ385	 JJ459  JJ615  JJ616  JJ617
HBS003  (22-29009B) M11x1.25x140mm (x10)	JC756  (31-025820-20) JC282  (31-024625-20)  JE120 (31-024767-00)	JN693 [128] (31-026198-10)	JJ385 [148] (50-026131-00)	PA565 (x8) (50-305900-50) HR342  (24-305900-05/0)	 NC006  35x48x7mm, MVQ (50-319161-00)  NB700  31x50x8mm, FPM (50-306551-50)  NB806  90x104x11mm, FPM (50-306552-00)	NB575 [2]  NB807 [2] 		
HBS416  (22-29025B) M11x1.50x163mm (x10)	KG5337  (50-350435-00) (MVQ) JD5868  (31-030346-00)				 NA5108  42x55x7mm, FPM (50-319392-00)  NB806  90x104x11mm, FPM (50-306552-00)			
HBS298  (22-29016B) M12x1.50x235mm (x10)	JD5255  (31-029721-00) JD5277  (31-029723-00) JD5256  (31-029722-00)	JM5159 (50-029633-00)	JH5057 (31-029575-00)	HR791  24-30614-76/0	 NA5069  55x68x8mm, FPM (50-319515-00)  NA5209  99x114x11mm, FPM (50-319514-00)			
HBS003  (22-29009B) M11x1.25x140mm (x10)	JC756  (31-025820-20) JC282  (31-024625-20)  JE120 (31-024767-00)	JN693 [128] (31-026198-10)	JJ385 [148] (50-026131-00)	PA565 (x8) (50-305900-50) HR342  (24-305900-05/0)	 NC006  35x48x7mm, MVQ (50-319161-00)  NB700  31x50x8mm, FPM (50-306551-50)  NB806  90x104x11mm, FPM (50-306552-00)	NB575 [2]  NB807 [2] 		
HBS035  (22-29005B) M11x1.25x110mm (x10) →Eng.14003804 HBS054  (22-29013B) M11x1.25x105mm (x10) Eng.14003805→	JD455  (31-026335-10) JD430  (31-025888-00)	JM950 (50-026336-10)	JJ459 (x2) [148] (31-027206-00)	PA565 (x16) (50-305900-50) HR342  (x2) (24-305900-05/0)	 NC006  (x2) 35x48x7mm, MVQ (50-319161-00)  NB884  38x50x5.5mm, FPM (50-319010-00)  NB806  90x104x11mm, FPM (50-306552-00)	NB575 [2]  NB807 [2] 		
HBS035  (22-29005B) M11x1.25x110mm (x10) →Eng.14137011 HBS054  (22-29013B) M11x1.25x105mm (x10) Eng.14137012→	JD451  (31-027699-00) JD450  (31-027684-00)  JE120 (31-024767-00)	JP016 (50-027683-00)	JJ615 (31-028793-00) JJ616  [212] (31-028386-00) JJ617  [212] (31-028385-00)	HR791  24-30614-76/0	 NC006  (x2) 35x48x7mm, MVQ (50-319161-00)  NB700  31x50x8mm, FPM (50-306551-50)  NB806  90x104x11mm, FPM (50-306552-00)			
HBS035  (22-29005B) M11x1.25x110mm (x10) →Eng.14003804 HBS054  (22-29013B) M11x1.25x105mm (x10) Eng.14003805→	JD455  (31-026335-10) JD456  (31-027459-00)	JM950 (50-026336-10)	JJ459 (x2) [148] (31-027206-00)	PA565 (x16) (50-305900-50) HR342  (x2) (24-305900-05/0)	 NC006  (x2) 35x48x7mm, MVQ (50-319161-00)  NB884  38x50x5.5mm, FPM (50-319010-00)  NB806  90x104x11mm, FPM (50-306552-00)	NB807 [2] 		

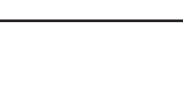

KW/PS



Calibra Coupe 2.5L i V6				04/93 → 07/97		77		BY270 (Fibre) (x2) (30-027690-00)		DY270 (21-27690-20/0) C25XE DY271 (21-27690-21/0) X25XE		EY300	
C 25 XE/X 25 XE	2498	6	81.60	Injection, DOHC, V6		125/170							
Campo 2.2L D Diesel				08/87 → 09/96		78		BM370 (Fibre) (30-028348-00)		DM370○ (21-28348-21/0)		GM370○ GM372■	
C223	2238	4	88.00	OHV		39-54/ 53-73		BR200 (Steel)					
Campo 2.3L				08/91 → 09/96		79		BP920 (Graphite) (30-028321-00)		DP920 (21-28321-20/0)		GP920 [131] GP921 [130]	
Campo 2.3L 4x4													
4 ZD1	2254	4	89.30			69-72/ 94-98							
23 P	2254	4	89.30			72/98							
Campo 2.5L D Diesel				08/91 → 06/94		80		BR990 (MLS)		DR990		GR990	
Campo 2.5L D 4x4 Diesel													
Campo 2.5L TD Diesel													
Campo 2.5L TD 4x4 Diesel													
4 JA1T	2499	4	93.00	Direct Injection, OHV		56/76							
4 JA1	2499	4	93.00	Direct Injection, OHV		56-74/ 76-101							
Campo 3.1L TD Diesel				12/92 →		81		AG7720 (Steel), 1.6mm, 1 Notch		CD5400▲		ER993	
Campo 3.1L TD 4x4 Diesel								AG7730 (Steel), 1.65mm, 2 Notches					
4 JG2T	3059	4	95.40	OHV		80/109		AD5400 (Fibre), 1.7mm, 3 Holes					
Combo 1.2L				07/94 → 10/01		82		BW170 (Fibre) (30-027215-00)		DW170 (21-27215-20/0)		ES260 [248] (22-27194-00/0)	
C 12 NZ/X 12 SZ	1195	4	72.00	SPi, SOHC		33/45							
Combo 1.3L CDTI 16V Diesel				10/04 →		83		AD5800 (MLS), 0.72mm (30-029762-00)		CD5800▲ (21-29762-20/0)			
Y 13 DT	1248	4	69.80	Direct Injection, DOHC		51/70		AD5810 (MLS), 0.82mm, 1 Hole (30-029763-00)					
Z 13 DT	1248	4	69.80	Direct Injection		51/70		AD5820 (MLS), 0.92mm, 2 Holes (30-029764-00)					
Combo 1.3L CDTI 16V Diesel				10/05 →		84				CD5810▲		ED5810 FD5810	
Z 13 DTJ	1248	4	69.60	Direct Injection		55/75							

									
HBS164  [22-29011B] M11x1.25x105mm (x16)	JD5202  (x2) (50-027980-00) X25XE JD5201  (31-027700-00) C25XE JD458   (31-027688-00) C25XE JD5203   (x3) (50-027979-00) X25XE JD457   (x2) (31-027686-00) C25XE JD459  (x2) (31-027698-00)	JM5095  (50-027697-00) JM5094  (50-027696-00) HM5294  [24-27696-00/0]	JH5052 (31-027689-00) → Eng.08077708 JJ573  (50-027851-00) Eng.08077709 → JJ572  (50-027852-00) Eng.08077709 →	HR5062  24-30614-73/0	NC006  (x4) 35x48x7mm, MVQ (50-319161-00) NB884  38x50x5.5mm, FPM (50-319010-00) NB806  90x104x11mm, FPM (50-306552-00)			 AD5800  AD5810  AD5820  BM370  BP920  BR200  BR990  BW170  BY270  JC281  JC643  JC683  JC684  JC824  JD457  JD458  JD459  JD5201	 JD5202  JD5203  JD5412  JM5094  JM5095  JN408  JN626  JN634  JN707  JH5005  JH5052  JJ120  JJ358  JJ470  JJ572  JJ573
HBS286  [22-20006B] M11x1.50x117mm (x3) M11x1.50x116mm (x16)	JC643   JE019	JN408	JH016		NJ267 42x55x9mm, NBR NJ266  65x84x9mm, NBR NJ265  82x105x13mm, MVQ			 NJ267  NJ266  NJ265  NJ454  NJ323  NJ322	
	JC684  JC683 	JN634 (50-028320-00) HL532 	JJ358 [131]	PA933  (x8)	NJ454 30x45x8mm, NBR NJ323  40x56x7mm, NBR NJ322  95x118x10mm, NBR			 JC684  JC683  JC281  JC643  JC683  JC684  JC824  JD457  JD458  JD459  JD5201	 JN634  HL532  JJ358  PA933  NJ454  NJ323  NJ322  JC281  JC643  JC683  JC684
		JN707	HC5008  JJ470	PA418 (x8)	NJ322  95x118x10mm, NBR			 JN707  HC5008  JJ470  PA418  NJ322	
HBS287  [22-20005B] M11x1.50x121mm (x18)			HC5008  JJ555					 HC5008  JJ555	
HBS002  [22-29098B] M10x1.25x140mm (x10)	JC824  (31-026334-00) JC281  (31-024312-10)	JN626 (31-026099-10)	JH5005 [116] (31-027194-00) JJ120	PA565 (x8) (50-305900-50) HR342  [24-30590-05/0]	NC006  35x48x7mm, MVQ (50-319161-00) NB697  26x42x8mm, FPM (50-306704-00) NB698  80x98x10mm, FPM (50-319273-00)			 JC824  JC281  JN626  JH5005  JJ120  PA565  NC006 NB697 NB698	 JN626  JH5005  JJ120  PA565  NC006  NB697  NB698
HBS353  [22-17025B] M10x1.25x119mm (x10)	JD5411  (50-030025-00) JD5412   (50-030026-00) JD5413  (31-030027-00) (MLS)	JM5259 (31-030023-00)	HR397 [57] 34-000410-00	HR5088  [24-31952-10/0]	NA5223  40x52x7mm, FPM (50-319520-00) NA5230  78x100x9mm, PTFE (50-319522-00)	KK5646 [45]		 JD5411  JD5412  JD5413  JM5259  HR397 HR5088 NA5223 NA5230 KK5646	 JM5259  HR397  HR5088  NA5223  NA5230 KK5646







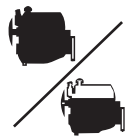



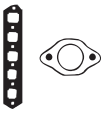

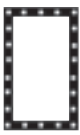



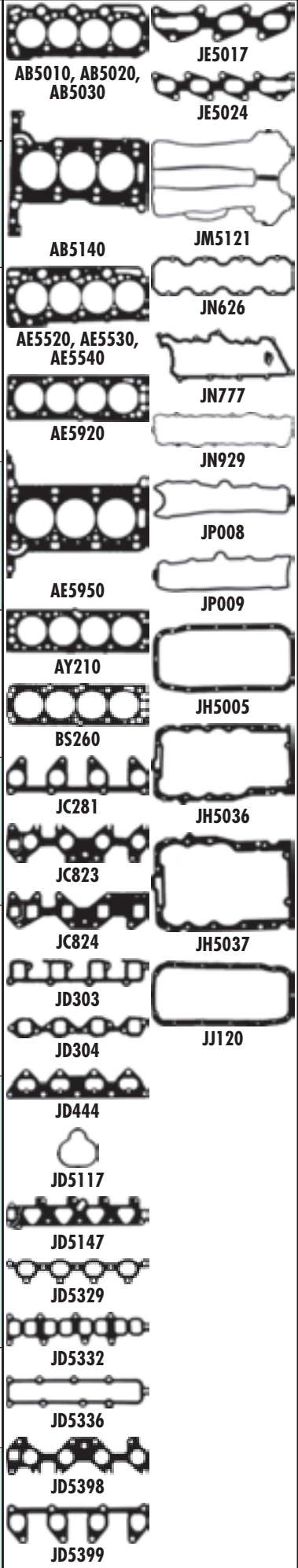























































OPEL



KW/PS



Combo 1.4L 10/04 → 85						AH5030 (MLS) (30-030366-00)	CH5030 (21-30366-00/0)	
Combo 1.4L 16V 08/05 →								
Z 14 XEP	1364	4	73.40	Injection, DOHC	66/89			
Combo 1.4L 07/94 → 10/01 86						BS260 (Fibre) (30-026329-10)	DS260 (21-26329-21/0) C14NZ DS261 (21-26329-22/0) X14SZ	EK470 (22-27194-05/0) C14NZ ES260 [248] (22-27194-00/0) X14SZ
X 14 SZ	1389	4	77.60	SPi, SOHC	40/44/ 54/60			
C 14 NZ	1389	4	77.60	SPi, SOHC	44/60			
Combo 1.4L 07/94 → 10/01 87						BS260 (Fibre) (30-026329-10)	DS261 (21-26329-22/0)	ES260 [248] (22-27194-00/0)
C 14 SE	1389	4	77.60	MPi, SOHC	60/82			
Combo 1.4L 16V 08/99 → 10/01 88						AY210 (Fibre) (30-027985-00)	CY211 (21-27985-22/0)	EY230 (22-27665-01/0)
X 14 XE	1389	4	77.60	Injection, DOHC	66/89			
Combo 1.6L 10/01 → 89						AE5920 (Steel) (30-029996-00)	CE5920 (21-29996-20/0)	EB5541 [8] (22-27665-03/0)
Z 16 SE	1598	4	79.00	Injection, SOHC	62/84			
Combo 1.7L D Diesel 07/94 → 10/01 90						AB5010 (MLS), 1.40mm (30-029163-00) AB5020 (MLS), 1.45mm, 1 Hole (30-029164-00) AB5030 (MLS), 1.50mm, 2 Holes (30-029165-00)	CY811 ▲■ (21-27776-22/0)	FY811 ▲ (20-27776-02/0)
17 D (4EE1)/X 17 D (4EE1)	1686	4	79.00	SOHC	44/60			
Combo 1.7L DI 16V Diesel 10/01 → 91						AE5520 (MLS), 1.45mm, 1 Hole (30-029904-00) AE5530 (MLS), 1.50mm, 2 Holes (30-029905-00) AE5540 (MLS), 1.55mm, 3 Notches (30-029906-00)	CE5521 ▲ (21-29904-21/0)	EE5520 (22-29904-00/0)
Combo 1.7L DTI 16V Diesel 10/01 →								
Y 17 DTL	1686	4	79.00	Direct Injection, DOHC	48/65			
Y 17 DT	1686	4	79.00	Direct Injection, DOHC	55/75			
Corsa 1.0L 09/00 → 92						AB5140 (MLS) (30-028029-00)	CB5141 ■☒ (21-28029-21/0)	EB5140 (22-29175-00/0)
Z 10 XE	973	3	72.50	Injection, DOHC	43/58			
Corsa 1.0L 06/03 → 93						AE5950 (Steel) (30-029101-00)	CE5950 (21-29101-00/0)	
Z 10 XEP	998	3	73.40	Injection, DOHC	44/60			







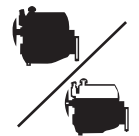



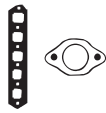

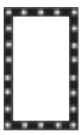

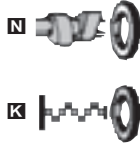

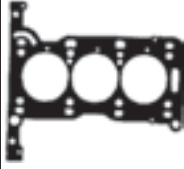
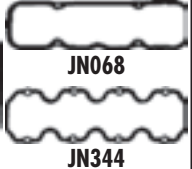
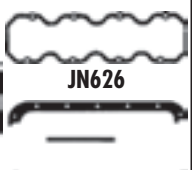
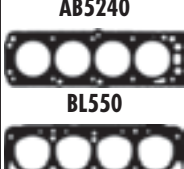

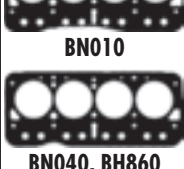
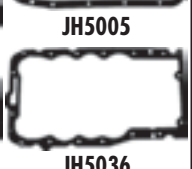
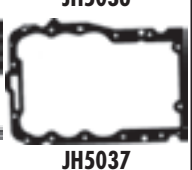
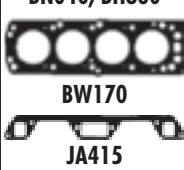
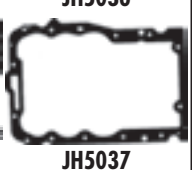
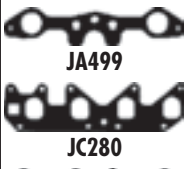

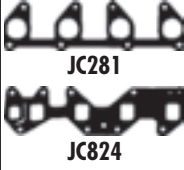
								
HBS252  (22-29014B) M8x1.25x119mm (x12)	JD5904  (x4) (50-030368-00) (FPM) JE5024  (31-029170-00)	JM5071 (50-029232-00)	JH5036 (31-029169-00)	HR5048  (24-31938-60/0)	NA5108  42x55x7mm, FPM (50-319392-00) NB698  80x98x10mm, FPM (50-319273-00)		JR5030 [11]	AB5010, AB5020, AB5030 JE5017 JE5024 AB5140 JM5121 AE5520, AE5530, AE5540 JN626 AE5920 JN777 JN929 JP008 AE5950 JP009 AY210 JH5005 BS260 JC281 JH5036 JC823 JH5037 JD303 JJ120 JD304 JD444 JD5117 JD5147 JD5329 JD5332 JD5336 JD5398 JD5399
HBS002  (22-29098B) M10x1.25x140mm (x10)	JC823  (31-027191-10) X14SZ JC824  (31-026334-00) C14NZ JC281  (31-024312-10)	JN626 (31-026099-10) C14NZ JN929 (50-027192-10) X14SZ	JH5005 [116] (31-027194-00) JJ120	PA565 (x8) (50-305900-50) HR342  (24-30590-05/0)	NC006  35x48x7mm, MVQ (50-319161-00) NB697  26x42x8mm, FPM (50-306704-00) NB698  80x98x10mm, FPM (50-319273-00)		NB575 [2] 	
HBS002  (22-29098B) M10x1.25x140mm (x10)	JC823  (31-027191-10) JC281  (31-024312-10)	JN929 (50-027192-10)	JH5005 [116] (31-027194-00) JJ120	PA565 (x8) (50-305900-50) HR342  (24-30590-05/0)	NC006  35x48x7mm, MVQ (50-319161-00) NB697  26x42x8mm, FPM (50-306704-00) NB698  80x98x10mm, FPM (50-319273-00)		NB575 [2] 	
HBS055  (22-29012B) M10x1.25x153mm (x10)	JD5147  (31-029203-00) JD444  (31-027878-00)	JP009  (50-027983-00) JP008  (50-027982-00)	JH5005 [116] (31-027194-00) JJ120	HR791  24-30614-76/0	NC006  (x2) 35x48x7mm, MVQ (50-319161-00) NB697  26x42x8mm, FPM (50-306704-00) NB698  80x98x10mm, FPM (50-319273-00)			
HBS002  (22-29098B) M10x1.25x140mm (x10)	JD5398  (31-029997-00) JD5399  (31-029998-00)	JN929 (50-027192-10)		PA565 (x8) (50-305900-50) HR342  (24-30590-05/0)	NC006  (x2) 35x48x7mm, MVQ (50-319161-00) NB697  26x42x8mm, FPM (50-306704-00) NB698  80x98x10mm, FPM (50-319273-00)			
HBS036  (22-29001B) M12x1.5x102mm (x10)	JD303  JD5914  (31-027778-00) JD304  JE5029  (31-027779-00)	JN777 (50-027776-00)		PA658 (x8) (50-319265-00)	NJ449 40x52x6mm, NBR (50-319266-00) NC004 (50-319268-00) NJ449  40x52x6mm, NBR (50-319266-00) NK103  87x100x8.5mm, FPM			
HBS036  (22-29001B) M12x1.5x102mm (x10)	JD5332  (31-029912-00) →Eng.721439 JD5333  (31-029913-00) Eng.721439 → JD5336  (31-029916-00) Eng.721439 → JD5329  (31-029909-00)	JM5197 (50-029907-00)		HR791  24-30614-76/0	NB884 38x50x5.5mm, FPM (50-319010-00) NJ449  40x52x6mm, NBR (50-319266-00) NK103  87x100x8.5mm, FPM			
HBS253  (22-29015B) M8x1.25x119mm (x10)	JD5117  (x3) (50-029186-00) JE5017  (31-029177-00)	JM5121 (50-029185-00)	JH5037 (31-029175-00)	PA5025 (x12) (50-319386-00) HR5096  (24-31938-61/0)	NA5108  42x55x7mm, FPM (50-319392-00) NB698  80x98x10mm, FPM (50-319273-00)		JR5030 [11]	
HBS253  (22-29015B) M8x1.25x119mm (x10) →Eng.19AQ2640	JD5904  (x4) (50-030368-00) (FPM) JE5017  (31-029177-00)	JM5121 (50-029185-00)	JH5037 (31-029175-00)	PA5025 (x12) (50-319386-00)	NA5108  42x55x7mm, FPM (50-319392-00) NB698  80x98x10mm, FPM (50-319273-00)		JR5030 [11]	

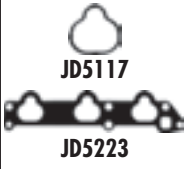

KW/PS



Corsa 1.0L						09/82 → 03/93	94	BN010 (Fibre)		DN010	ET820
Corsa Van 1.0L						02/86 → 04/89		(30-025128-10)		(21-25128-24/0)	(22-20159-02/0)
10 S	993	4	72.00	Carburettor, OHV	33-35/ 45-48				01/73 → 12/84		
Corsa 1.0L i 12V						11/96 → 09/00	95	AB5140 (MLS)		CB5140	EB5140
X 10 XE	973	3	72.50	Injection, DOHC	40/54			(30-028029-00)		(21-28029-20/0)	(22-29175-00/0)
Corsa 1.2L						09/00 →	96	AB5240 (MLS)		CB5240	EB5240
Z 12 XE	1199	4	72.50	Injection, DOHC	55/75			(30-028390-20) → Ch.3G9999999		(21-28390-21/0) → Ch.3G9999999	(22-29169-00/0)
								AH5030 (MLS) (30-030366-00) Ch.4G000001 →		CH5030 (21-30366-00/0) Ch.4G000001 →	
Corsa 1.2L						09/82 → 08/90	97	BN040 (Fibre), 1.36mm		DN041	ET820
Corsa 1.2L S						09/82 → 10/87		(30-022712-20)		(21-22712-26/0)	(22-20159-02/0)
Corsa Van 1.2L						02/86 → 07/90		BH860 (Fibre), 1.70mm			
12 NC/E 12 GV	1196	4	79.00	Carburettor, OHV	33/45			(30-023271-20)			
12 S	1196	4	79.00	OHV	40-44/ 54-60						
Corsa 1.2L						07/06 →	98	AH5030 (MLS)		CH5031	
Corsa 1.2L Twinport						07/04 →		(30-030366-00)		(21-30366-01/0)	
Corsa Van 1.2L						07/05 →					
Z 12 XEP	1229	4	73.40	Injection, DOHC	59/80						
Corsa 1.2L i						09/89 → 09/00	99	BW170 (Fibre)		DW170	
12 NZ	1195	4	72.00	Injection, SOHC	33/45			(30-027215-00)		(21-27215-20/0)	
C 12 NZ/X 12 SZ	1195	4	72.00	SPi, SOHC	33/45						
Corsa 1.2L i 16V						03/98 → 09/00	100	AB5240 (MLS)		CB5241	EB5240
X 12 XE	1199	4	72.50	Injection, DOHC	48/65			(30-028390-20)		(21-28390-20/0)	(22-29169-00/0)
Corsa 1.2L N						01/85 → 10/87	101	BN040 (Fibre), 1.36mm		DN041	ET820
12 NC/E 12 GV	1196	4	79.00	Carburettor, OHV	33/45			(30-022712-20)		(21-22712-26/0)	(22-20159-02/0)
Corsa 1.2L N						01/90 → 03/93	102	BL550 (Fibre)		DL551	EK470
Corsa Van 1.2L						02/86 → 04/89		(30-024666-10)		(21-24666-23/0)	(22-27194-05/0)
12 NV	1196	4	77.80	Carburettor, SOHC	38/52						
12 ST	1196	4	77.80	Carburettor, SOHC	40-43/ 55-58						
Corsa 1.2L S						09/82 → 03/93	103	BL550 (Fibre)		DL550	EK470
12 ST	1196	4	77.80	Carburettor, SOHC	40-43/ 55-58			(30-024666-10)		(21-24666-24/0) → 12/85	(22-27194-05/0)
										DL551 (21-24666-23/0) 01/86 →	











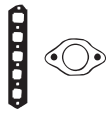

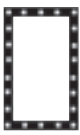

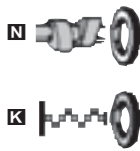













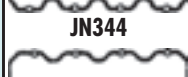
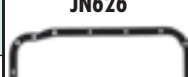

















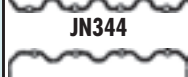
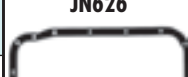















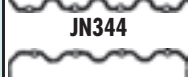
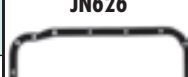













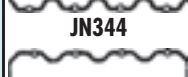
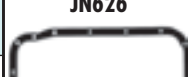













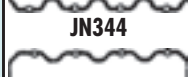
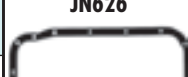















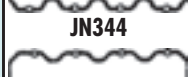
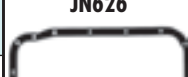















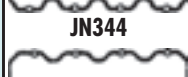
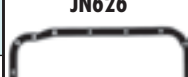







								
HBS112 (22-29006B) M9x1.25x80mm (x5) M9x1.25x100mm (x5)	JA499 JA415 (31-020165-10)	JN068 (31-023120-10) 01/73 → 12/84	HC288 (23-20161-01/0)	HR291 (50-024209-00)	NB691 54x82x9mm, ACM			 AB5140  JN344  JN626
HBS253 (22-29015B) M8x1.25x119mm (x10)	JD5223 JE5017 (31-029177-00)	JM5085 (50-029176-00)	JH5037 (31-029175-00)	PA5025 (x12) (50-319386-00) HR5096 (24-31938-61/0)	NA5108 42x55x7mm, FPM NB698 80x98x10mm, FPM (50-319273-00)		JR5030 [11]	 AB5240  HC288
HBS252 (22-29014B) M8x1.25x119mm (x12)	JD5117 (x4) (50-029186-00) → Ch.3G999999 JD5904 (x4) (50-030368-00) (FPM) Ch.4G000001 → JE5024 (31-029170-00)	JM5048 (50-029167-00) → Ch.1G001502 JM5071 (50-029232-00) Ch.1G001503 →	JH5036 (31-029169-00)	HR5048 (24-31938-60/0)	NA5108 42x55x7mm, FPM NB698 80x98x10mm, FPM (50-319273-00)		JR5030 [11]	 BL550  BN010  JH5005
HBS112 (22-29006B) M9x1.25x80mm (x5) M9x1.25x100mm (x5)	JA499 JA415 (31-020165-10)	JN068 (31-023120-10)	HC288 (23-20161-01/0)	HR291 (50-024209-00)	NB691 54x82x9mm, ACM		NB575 [2]	 BN040, BH860  JH5036
HBS252 (22-29014B) M8x1.25x119mm (x12)	JD5904 (x4) (50-030368-00) (FPM)	JM5071 (50-029232-00)	JH5036 (31-029169-00)	HR5048 (24-31938-60/0)	NA5108 42x55x7mm, FPM NB698 80x98x10mm, FPM (50-319273-00)		JR5030 [11]	 BW170  JA415  JA499  JH5037
HBS002 (22-29098B) M10x1.25x140mm (x10)	JC824 (31-026334-00) JC281 (31-024312-10)	JN626 (31-026099-10)	JH5005 [116] (31-027194-00) JJ120	PA565 (x8) (50-305900-50) HR342 (24-30590-05/0)	NC006 35x48x7mm, MVQ (50-319161-00) NB697 26x42x8mm, FPM (50-306704-00) NB698 80x98x10mm, FPM (50-319273-00)			 JC280  JC281  JC824  JD5117
HBS252 (22-29014B) M8x1.25x119mm (x12)	JE5024 (31-029170-00)	JM5048 (50-029167-00)	JH5036 (31-029169-00)	HR5048 (24-31938-60/0)	NA5108 42x55x7mm, FPM NB698 80x98x10mm, FPM (50-319273-00)		JR5030 [11]	 JD5223  JE5017
HBS112 (22-29006B) M9x1.25x80mm (x5) M9x1.25x100mm (x5)	JA499 JA415 (31-020165-10)	JN068 (31-023120-10)	HC288 (23-20161-01/0)	HR291 (50-024209-00)	NB691 54x82x9mm, ACM		NB575 [2]	 JE5024
HBS002 (22-29098B) M10x1.25x140mm (x10)	JC280 (31-024313-10) JC281 (31-024312-10)	JN626 (31-026099-10)	JH5005 [116] (31-027194-00) JJ120	PA565 (x8) (50-305900-50) HR342 (24-30590-05/0)	NC006 35x48x7mm, MVQ (50-319161-00) NB697 26x42x8mm, FPM (50-306704-00) NB698 80x98x10mm, FPM (50-319273-00)		NB575 [2]	 JM5048
HBS002 (22-29098B) M10x1.25x140mm (x10)	JC280 (31-024313-10) JC281 (31-024312-10)	JN344 (31-024299-00) → 12/85 JN626 (31-026099-10) 01/86 →	JH5005 [116] (31-027194-00) JJ120	PA565 (x8) (50-305900-50) HR342 (24-30590-05/0)	NC006 35x48x7mm, MVQ (50-319161-00) NB697 26x42x8mm, FPM (50-306704-00) NB698 80x98x10mm, FPM (50-319273-00)		NB575 [2]	 JM5085



KW/PS

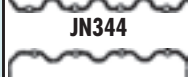
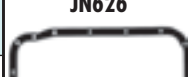

Corsa 1.3L		09/85 → 10/87		104	BK470 (Fibre) (30-024033-10)	DK470 (21-24033-26/0) →12/86 DK471 (21-24033-30/0) 01/87 →	EK470 (22-27194-05/0)
13 NB	1297	4	75.00	Carburettor, SOHC	44/60		
C 13 N	1297	4	75.00	SPi, SOHC	44/60		
Corsa 1.3L		09/85 → 10/89		105	BK470 (Fibre) (30-024033-10)	DK470 (21-24033-26/0) →12/86 DK471 (21-24033-30/0) 01/87 →	EK470 (22-27194-05/0)
Corsa Van 1.3L		02/86 → 04/89					
13 NB	1297	4	75.00	Carburettor, SOHC	44/60		
Corsa 1.3L CDTI Diesel		06/03 →		106	AD5800 (MLS), 0.72mm (30-029762-00)	CD5800▲ (21-29762-20/0)	
Corsa Van 1.3L CDTI 16V Diesel		08/05 →					
Z 13 DT	1248	4	69.80	Direct Injection	51/70		
					AD5810 (MLS), 0.82mm, 1 Hole (30-029763-00)		
					AD5820 (MLS), 0.92mm, 2 Holes (30-029764-00)		
Corsa 1.3L CDTI Diesel		07/06 →		107	AD5800 (MLS), 0.72mm (30-029762-00)		
Z 13 DTJ	1248	4	69.60	Direct Injection	55/75		
					AD5810 (MLS), 0.82mm, 1 Hole (30-029763-00)		
					AD5820 (MLS), 0.92mm, 2 Holes (30-029764-00)		
Corsa 1.3L CDTI Diesel		07/06 →		108		CD5820▲	ED5820 FD5820▲
Z 13 DTH	1248	4	69.60	Direct Injection	66-74/ 90-101		
Corsa 1.3L i		09/86 → 09/90		109	BK470 (Fibre) (30-024033-10)	DK471 (21-24033-30/0)	EK470 (22-27194-05/0)
C 13 N	1297	4	75.00	SPi, SOHC	44/60		
					BH860 (Fibre), 1.70mm (30-023271-20)		
Corsa 1.3L S		09/82 → 10/89		110	BK470 (Fibre) (30-024033-10)	DK470 (21-24033-26/0) →12/85 DK471 (21-24033-30/0) 01/86 →	EK470 (22-27194-05/0)
13 SB	1297	4	75.00	Carburettor, SOHC	51/70		
Corsa Van 1.3L		02/86 → 04/89		111	BK470 (Fibre) (30-024033-10)	DK471 (21-24033-30/0)	EK470 (22-27194-05/0)
13 SB	1297	4	75.00	Carburettor, SOHC	51/70		
Corsa 1.4L		09/00 →		112	AB5360 (MLS) (30-029200-00)	CB5360 (21-29200-20/0)	EB5360 (22-27665-02/0) Eng.02M25253 → Eng.20U75999 → EB5541 [8] (22-27665-03/0) Eng.02M25254 → Eng.20U76000 →
Z 14 XE	1389	4	77.60	Injection, DOHC	66/89		
Corsa 1.4L		08/03 →		113	AH5030 (MLS) (30-030366-00)	CH5030 (21-30366-00/0)	
Z 14 XEP	1364	4	73.40	Injection, DOHC	66/89		







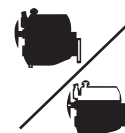



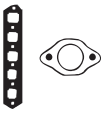

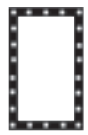

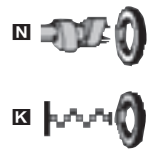













								
HBS002 Ⓢ (22-29098B) M10x1.25x140mm (x10)	JC280 ■ (31-024313-10) JC281 ■ (31-024312-10) ☉ JE119 (31-024520-00)	JN344 (31-024299-00) →12/86 JN626 (31-026099-10) 01/87→	JH5005 [116] (31-027194-00) JJ120	PA565 (x8) (50-305900-50) HR342 ■ (24-30590-05/0)	NC006 ■ 35x48x7mm, MVQ (50-319161-00) NB697 ■ 26x42x8mm, FPM (50-306704-00) NB698 ■ 80x98x10mm, FPM (50-319273-00)	NB575 [2]■		 AB5360  AD5800  AD5810  AD5820  BH860  BK470  JC280  JC281  JD5147  JD5148  JD5149  JD5412  JE119  JM5059  JN344  JN626  JH5005  JJ120  JJ575
HBS002 Ⓢ (22-29098B) M10x1.25x140mm (x10)	JC280 ■ (31-024313-10) JC281 ■ (31-024312-10) ☉ JE119 (31-024520-00)	JN344 (31-024299-00) →12/86 JN626 (31-026099-10) 01/87→	JH5005 [116] (31-027194-00) JJ120	PA565 (x8) (50-305900-50) HR342 ■ (24-30590-05/0)	NC006 ■ 35x48x7mm, MVQ (50-319161-00) NB697 ■ 26x42x8mm, FPM (50-306704-00) NB698 ■ 80x98x10mm, FPM (50-319273-00)	NB575 [2]■		 AD5810  AD5820  BH860  BK470  JC280  JC281  JD5147  JD5148  JD5149  JD5412  JE119  JM5059  JN344  JN626  JH5005  JJ120  JJ575
HBS353 Ⓢ (22-17025B) M10x1.25x119mm (x10)	JD5411 ■ (50-030025-00) JD5412 ■ (50-030026-00) JD5413 ■ (31-030027-00) (MLS)	JM5259 (31-030023-00)	HR397 [57] 34-000410-00	HR5088 ■ (24-31952-10/0)	NA5223 ■ 40x52x7mm, FPM (50-319520-00) NA5230 ■ 78x100x9mm, PTFE (50-319522-00)	KK5646 [45]		 BH860  BK470  JC280  JC281  JD5147  JD5148  JD5149  JD5412  JE119  JM5059  JN344  JN626  JH5005  JJ120  JJ575
HBS353 Ⓢ (22-17025B) M10x1.25x119mm (x10)	JD5413 ■ (31-030027-00) (MLS)		HR397 [57] 34-000410-00	HR5088 ■ (24-31952-10/0)	NA5223 ■ 40x52x7mm, FPM (50-319520-00) NA5230 ■ 78x100x9mm, PTFE (50-319522-00)			 BH860  BK470  JC280  JC281  JD5147  JD5148  JD5149  JD5412  JE119  JM5059  JN344  JN626  JH5005  JJ120  JJ575
HBS002 Ⓢ (22-29098B) M10x1.25x140mm (x10)	JC280 ■ (31-024313-10) JC281 ■ (31-024312-10) ☉ JE119 (31-024520-00)	JN626 (31-026099-10)	JH5005 [116] (31-027194-00) JJ120	PA565 (x8) (50-305900-50) HR342 ■ (24-30590-05/0)	NC006 ■ 35x48x7mm, MVQ (50-319161-00) NB697 ■ 26x42x8mm, FPM (50-306704-00) NB698 ■ 80x98x10mm, FPM (50-319273-00)	NB575 [2]■		 AD5810  AD5820  BH860  BK470  JC280  JC281  JD5147  JD5148  JD5149  JD5412  JE119  JM5059  JN344  JN626  JH5005  JJ120  JJ575
HBS002 Ⓢ (22-29098B) M10x1.25x140mm (x10)	JC280 ■ (31-024313-10) JC281 ■ (31-024312-10) ☉ JE119 (31-024520-00)	JN626 (31-026099-10)	JH5005 [116] (31-027194-00) JJ120	HR342 ■ (24-30590-05/0)	NC006 ■ 35x48x7mm, MVQ (50-319161-00) NB697 ■ 26x42x8mm, FPM (50-306704-00) NB698 ■ 80x98x10mm, FPM (50-319273-00)	NB575 [2]■		 AD5810  AD5820  BH860  BK470  JC280  JC281  JD5147  JD5148  JD5149  JD5412  JE119  JM5059  JN344  JN626  JH5005  JJ120  JJ575
HBS055 Ⓢ (22-29012B) M10x1.25x153mm (x10)	JD5147 ■ (31-029203-00) JD5149 ■ (31-029207-00) JD5148 ■ (31-029204-00)	JM5059 (50-029202-00)	JJ575 [148] (50-027665-00) →Eng.02M25253 →Eng.20U75999	HR791 ■ 24-30614-76/0	NC006 ■ (x2) 35x48x7mm, MVQ (50-319161-00) NB697 ■ 26x42x8mm, FPM (50-306704-00) NB698 ■ 80x98x10mm, FPM (50-319273-00)			 AD5810  AD5820  BH860  BK470  JC280  JC281  JD5147  JD5148  JD5149  JD5412  JE119  JM5059  JN344  JN626  JH5005  JJ120  JJ575
	JD5904 ■ (x4) (50-030368-00) (FPM)	JM5071 (50-029232-00)						 AD5810  AD5820  BH860  BK470  JC280  JC281  JD5147  JD5148  JD5149  JD5412  JE119  JM5059  JN344  JN626  JH5005  JJ120  JJ575



KW/PS

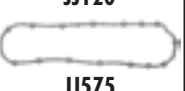

Corsa 1.4L i						10/89 → 03/93	114	BS260 (Fibre) (30-026329-10)	DS260 (21-26329-21/0)	EK470 (22-27194-05/0)
Corsa 1.4L S						09/89 → 03/93				
C 14 NZ	1389	4	77.60	SPi, SOHC	44/60					
14 NV	1389	4	77.60	Carburettor, SOHC	53-55/ 72-75					
Corsa 1.4L i						03/93 → 09/00	115	BS260 (Fibre) (30-026329-10)	DS260 (21-26329-21/0) C14NZ DS261 (21-26329-22/0) X14SZ	EK470 (22-27194-05/0) C14NZ ES260 [248] (22-27194-00/0) X14SZ
X 14 SZ	1389	4	77.60	SPi, SOHC	40-44/ 54-60					
C 14 NZ	1389	4	77.60	SPi, SOHC	44/60					
Corsa 1.4L i						08/97 → 09/00	116	BS260 (Fibre) (30-026329-10)	DS261 (21-26329-22/0)	ES260 [248] (22-27194-00/0)
Corsa 1.4L Si						09/91 → 09/00				
C 14 SE	1389	4	77.60	MPI, SOHC	60/82					
C 14 SEL	1389	4	77.60	Injection, SOHC	63/86					
Corsa 1.4L i 16V						09/94 → 09/00	117	AY210 (Fibre) (30-027985-00)	CY210 (21-27985-21/0)	EY230 (22-27665-01/0)
X 14 XE	1389	4	77.60	Injection, DOHC	66/89					
Corsa 1.4L Twinport						06/03 →	118	AH5030 (MLS) (30-030366-00)	CH5030 (21-30366-00/0)	
Z 14 XEP	1364	4	73.40	Injection, DOHC	66/89					
Corsa Van 1.4L i						08/99 → 09/00	119	BS260 (Fibre) (30-026329-10)	DS261 (21-26329-22/0)	ES260 [248] (22-27194-00/0)
X 14 SZ	1389	4	77.60	SPi, SOHC	40-44/ 54-60					
Corsa 1.5L D Diesel						09/87 → 09/00	120	AY840 (MLS), 1.40mm (30-028998-00) → Eng.975024	CY811▲■ (21-27776-22/0)	FY811 ▲ (20-27776-02/0)
Corsa 1.5L TD Diesel						10/87 → 09/00				
Corsa Van 1.5L D Diesel						06/87 → 04/89				
15 D (4EC1)	1488	4	76.00	SOHC	37/50					
X 15 DT (T4EC1)	1488	4	76.00	SOHC	49/67		AY850 (MLS), 1.45mm, 1 Hole (30-028999-00) → Eng.975024			
15 DT (T4EC1)	1488	4	76.00	SOHC	49-53/ 67-72		AY860 (MLS), 1.50mm, 2 Holes (30-029000-00) → Eng.975024			
							AY900 (MLS), 1.40mm (30-029007-00) Eng.975025 →			
							AY910 (MLS), 1.45mm, 1 Hole (30-029006-00) Eng.975025 →			
							AY920 (MLS), 1.50mm, 2 Holes (30-029008-00) Eng.975025 →			







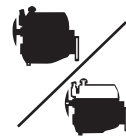



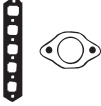

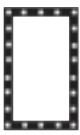

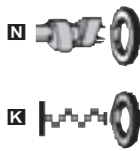

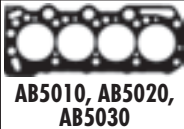













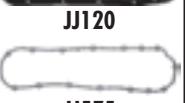



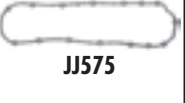

								
HBS002 ® [22-29098B] M10x1.25x140mm (x10)	JC824 ■ (31-026334-00) JC281 ■ (31-024312-10)	JN626 (31-026099-10)	JH5005 [116] (31-027194-00) JJ120	PA565 (x8) (50-305900-50) HR342 ■ (24-30590-05/0)	NC006 ■ 35x48x7mm, MVQ (50-319161-00) NB697 ■ 26x42x8mm, FPM (50-306704-00) NB698 ■ 80x98x10mm, FPM (50-319273-00)	NB575 [2]■		 AY210  AY840, AY850, AY860  AY900, AY910, AY920  BS260  JC281  JC823  JC824  JD303  JD304  JD444  JD445  JD5269  JE5024  JN626  JN777  JN929  JP008  JP009  JH5005
HBS002 ® [22-29098B] M10x1.25x140mm (x10)	JC823 ■ (31-027191-10) JC824 ■ (31-026334-00) JC281 ■ (31-024312-10)	JN626 (31-026099-10) JN929 (50-027192-10) X14SZ	JH5005 [116] (31-027194-00) JJ120	PA565 (x8) (50-305900-50) HR342 ■ (24-30590-05/0)	NC006 ■ 35x48x7mm, MVQ (50-319161-00) NB697 ■ 26x42x8mm, FPM (50-306704-00) NB698 ■ 80x98x10mm, FPM (50-319273-00)	NB575 [2]■		 JH5036  JH5058  JJ120  JJ575
HBS002 ® [22-29098B] M10x1.25x140mm (x10)	JC823 ■ (31-027191-10) JC281 ■ (31-024312-10)	JN929 (50-027192-10)	JH5005 [116] (31-027194-00) JJ120	PA565 (x8) (50-305900-50) HR342 ■ (24-30590-05/0)	NC006 ■ 35x48x7mm, MVQ (50-319161-00) NB697 ■ 26x42x8mm, FPM (50-306704-00) NB698 ■ 80x98x10mm, FPM (50-319273-00)	NB575 [2]■		
HBS055 ® [22-29012B] M10x1.25x153mm (x10)	JD5269 ■ (31-027984-00) JD445 ■ (31-027881-00) JD444 ■ (31-027878-00)	JP009 ■ (50-027983-00) JP008 ■ (50-027982-00)	JJ575 [148] (50-027665-00)	HR791 ■ 24-30614-76/0	NC006 ■ (x2) 35x48x7mm, MVQ (50-319161-00) NB697 ■ 26x42x8mm, FPM (50-306704-00) NB698 ■ 80x98x10mm, FPM (50-319273-00)			 JR5030 [11]
HBS252 ® [22-29014B] M8x1.25x119mm (x12)	JD5904 ■ (x4) (50-030368-00) (FPM) JE5024 ■ (31-029170-00)	JM5071 (50-029232-00)	JH5036 (31-029169-00)	HR5048 ■ (24-31938-60/0)	NA5108 ■ 42x55x7mm, FPM (50-319392-00) NB698 ■ 80x98x10mm, FPM (50-319273-00)			
HBS002 ® [22-29098B] M10x1.25x140mm (x10)	JC823 ■ (31-027191-10) JC281 ■ (31-024312-10)	JN929 (50-027192-10)	JH5005 [116] (31-027194-00) JJ120	HR342 ■ (24-30590-05/0)	NC006 ■ 35x48x7mm, MVQ (50-319161-00) NB697 ■ 26x42x8mm, FPM (50-306704-00) NB698 ■ 80x98x10mm, FPM (50-319273-00)	NB575 [2]■		
HBS036 ® [22-29001B] M12x1.5x102mm (x10)	JD303 ■ JD304 ■	JN776 →12/89 JN777 (50-027776-00) 01/90→	JH5058 (31-027781-00)	PA658 (x8) (50-319265-00)	NJ449 ■ 40x52x6mm, NBR (50-319266-00) NJ449 ■ 40x52x6mm, NBR (50-319266-00) NK103 ■ 87x100x8.5mm, FPM			



KW/PS



Corsa 1.6L GSI						05/88 → 09/92	121	BP800 (Fibre) (30-025706-20)	DP802 (21-25706-25/0)	EK484 [129] (22-27194-01/0)
C 16 NZ	1598	4	79.00	SPi, SOHC	55/75	121	BP800 (Fibre) (30-025706-20)	DP802 (21-25706-25/0)	EK484 [129] (22-27194-01/0)	
E 16 SE	1598	4	79.00	MPi, SOHC	74/100					
Corsa 1.6L GSI						09/89 → 03/93	122	BP800 (Fibre) (30-025706-20)	DP803	EK484 [129] (22-27194-01/0)
C 16 SEI	1598	4	79.00	MPi, SOHC	72/98	122	BP800 (Fibre) (30-025706-20)	DP803	EK484 [129] (22-27194-01/0)	
C 16 SE	1598	4	79.00	MPi, SOHC	74/100					
Corsa 1.6L GSI 16V						03/93 → 09/00	123	AY220 (Fibre)	DY231 (21-27986-23/0)	EY230 (22-27665-01/0)
C 16 XE	1598	4	79.00	MPi, DOHC	80/109	123	AY220 (Fibre)	DY231 (21-27986-23/0)	EY230 (22-27665-01/0)	
Corsa 1.6L i 16V						08/97 → 09/00	124	BP800 (Fibre) (30-025706-20)	DP803	EK484 [129] (22-27194-01/0)
C 16 SEL	1598	4	79.00	Injection, SOHC	78/106	124	BP800 (Fibre) (30-025706-20)	DP803	EK484 [129] (22-27194-01/0)	
Corsa 1.6L i 16V						09/94 → 09/00	125	AY220 (Fibre)	CY220 (21-27986-21/0)	EY230 (22-27665-01/0)
X 16 XE	1598	4	79.00	Injection, DOHC	78/106	125	AY220 (Fibre)	CY220 (21-27986-21/0)	EY230 (22-27665-01/0)	
Corsa 1.7L CDTI Diesel						06/03 →	126	AE5520 (MLS), 1.45mm, 1 Hole (30-029904-00) AE5530 (MLS), 1.50mm, 2 Holes (30-029905-00) AE5540 (MLS), 1.55mm, 3 Notches (30-029906-00)	CE5523▲ (21-29904-23/0)	EE5520 (22-29904-00/0)
Z 17 DTH	1686	4	79.00	Direct Injection, DOHC	74/100	126	AE5520 (MLS), 1.45mm, 1 Hole (30-029904-00) AE5530 (MLS), 1.50mm, 2 Holes (30-029905-00) AE5540 (MLS), 1.55mm, 3 Notches (30-029906-00)	CE5523▲ (21-29904-23/0)	EE5520 (22-29904-00/0)	
Corsa 1.7L DI Diesel						09/00 →	127	AE5520 (MLS), 1.45mm, 1 Hole (30-029904-00) AE5530 (MLS), 1.50mm, 2 Holes (30-029905-00) AE5540 (MLS), 1.55mm, 3 Notches (30-029906-00)	CE5521▲ (21-29904-21/0)	EE5520 (22-29904-00/0)
Corsa 1.7L DTI Diesel						09/00 →				
Corsa Van 1.7L DI 16V Diesel						09/00 →				
Corsa Van 1.7L DTI 16V Diesel						09/00 →				
Y 17 DTL	1686	4	79.00	Direct Injection, DOHC	48/65	127	AE5520 (MLS), 1.45mm, 1 Hole (30-029904-00) AE5530 (MLS), 1.50mm, 2 Holes (30-029905-00) AE5540 (MLS), 1.55mm, 3 Notches (30-029906-00)	CE5521▲ (21-29904-21/0)	EE5520 (22-29904-00/0)	
Y 17 DT	1686	4	79.00	Direct Injection, DOHC	55/75					
Corsa Van 1.7L D Diesel						08/99 → 09/00	128	AB5010 (MLS), 1.40mm (30-029163-00) AB5020 (MLS), 1.45mm, 1 Hole (30-029164-00) AB5030 (MLS), 1.50mm, 2 Holes (30-029165-00)	CY811▲■ (21-27776-22/0)	FY811▲ (20-27776-02/0)
17 D (4EE1)/X 17 D (4EE1)	1686	4	79.00	SOHC	44/60	128	AB5010 (MLS), 1.40mm (30-029163-00) AB5020 (MLS), 1.45mm, 1 Hole (30-029164-00) AB5030 (MLS), 1.50mm, 2 Holes (30-029165-00)	CY811▲■ (21-27776-22/0)	FY811▲ (20-27776-02/0)	
Corsa 1.8L						09/00 →	129	AC5460 (MLS) (30-028674-00)	CC5460 (21-28674-20/0)	
Z 18 XE	1796	4	80.50	MPi, DOHC	92/125	129	AC5460 (MLS) (30-028674-00)	CC5460 (21-28674-20/0)		











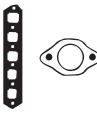



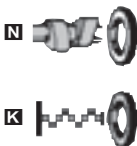

























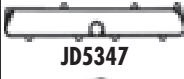







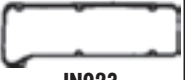







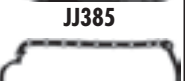





















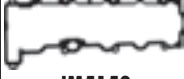

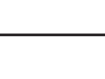









































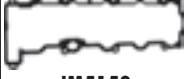

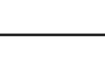







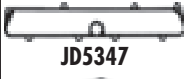











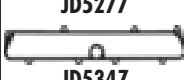







								
HBS002 ® (22-29098B) M10x1.25x140mm (x10)	JC824 ■ (31-026334-00) JC281 ■ (31-024312-10) ☉ JE120 (31-024767-00)	JN626 (31-026099-10)	JH5005 (x2) [116] (31-027194-00) JJ120 (x2)	PA565 (x8) (50-305900-50) HR342 ■ (24-305900-05/0)	N NC006 ■ 35x48x7mm, MVQ (50-319161-00) K NB697 ■ 26x42x8mm, FPM (50-306704-00) NB698 ■ 80x98x10mm, FPM (50-319273-00)	NB575 [2]■	 AB5010, AB5020, AB5030  AC5460  AE5520, AE5530, AE5540	 JN626  JN777  JN929  JP008
HBS002 ® (22-29098B) M10x1.25x140mm (x10)	JC823 ■ (31-027191-10) JC281 ■ (31-024312-10) ☉ JE120 (31-024767-00)	JN929 (50-027192-10)	JH5005 [116] (31-027194-00) JJ120	PA565 (x8) (50-305900-50) HR342 ■ (24-305900-05/0)	N NC006 ■ 35x48x7mm, MVQ (50-319161-00) K NB697 ■ 26x42x8mm, FPM (50-306704-00) NB698 ■ 80x98x10mm, FPM (50-319273-00)		 AY220  BP800	 JP009  JP008
HBS055 ® (22-29012B) M10x1.25x153mm (x10)	JD448 ■ (31-027880-00) JD444 ■ (31-027878-00)	JP009 ■ (50-027983-00) JP008 ■ (50-027982-00)	JJ575 [148] (50-027665-00)	HR791 ■ 24-30614-76/0	N NC006 ■ (x2) 35x48x7mm, MVQ (50-319161-00) K NB697 ■ 26x42x8mm, FPM (50-306704-00) NB698 ■ 80x98x10mm, FPM (50-319273-00)		 JC281  JC823  JC824	 JH5005  JJ120
HBS002 ® (22-29098B) M10x1.25x140mm (x10)	JC823 ■ (31-027191-10) JC281 ■ (31-024312-10)	JN929 (50-027192-10)	JH5005 [116] (31-027194-00) JJ120	HR342 ■ (24-305900-05/0)	N NC006 ■ (x2) 35x48x7mm, MVQ (50-319161-00) K NB697 ■ 26x42x8mm, FPM (50-306704-00) NB698 ■ 80x98x10mm, FPM (50-319273-00)		 JD303  JD304  JD444	 JJ575
HBS055 ® (22-29012B) M10x1.25x153mm (x10)	JD448 ■ (31-027880-00) JD445 ■■ (31-027881-00) JD444 ■ (31-027878-00)	JP009 ■ (50-027983-00) JP008 ■ (50-027982-00)	JJ575 [148] (50-027665-00)	HR791 ■ 24-30614-76/0	N NC006 ■ (x2) 35x48x7mm, MVQ (50-319161-00) K NB697 ■ 26x42x8mm, FPM (50-306704-00) NB698 ■ 80x98x10mm, FPM (50-319273-00)		 JD445  JD448  JD5196	
HBS036 ® (22-29001B) M12x1.5x102mm (x10)	JD5334 ■ (31-029914-00) JD5331 ■ (x2) (31-029911-00)	JM5198 (50-029908-00)		HR791 ■ 24-30614-76/0	N NB884 38x50x5.5mm, FPM (50-319010-00) NJ449 ■ 40x52x6mm, NBR (50-319266-00) NK103 ■ 87x100x8.5mm, FPM		 JD5197  JD5329  JD5331	
HBS036 ® (22-29001B) M12x1.5x102mm (x10)	JD5332 ■ (31-029912-00) →Eng.721439 JD5333 ■ (31-029913-00) Eng.721439 → JD5336 ■■ (31-029916-00) Eng.721439 → JD5329 ■ (31-029909-00)	JM5197 (50-029907-00)		HR791 ■ 24-30614-76/0	N NB884 38x50x5.5mm, FPM (50-319010-00) NJ449 ■ 40x52x6mm, NBR (50-319266-00) NK103 ■ 87x100x8.5mm, FPM		 JD5332  JD5334  JD5336  JE120	
HBS036 ® (22-29001B) M12x1.5x102mm (x10)	JD303 ■ JD5914 ■ (31-027778-00) JD304 ■ ☉ JE5029 (31-027779-00)	JN777 (50-027776-00)		PA658 (x8) (50-319265-00)	N NJ449 40x52x6mm, NBR (50-319266-00) NJ449 ■ 40x52x6mm, NBR (50-319266-00) NK103 ■ 87x100x8.5mm, FPM		 JM5092	
HBS055 ® (22-29012B) M10x1.25x153mm (x10)	JD5196 ■ (31-029039-00) JD5197 ■ (31-029040-00)	JM5092 (50-029087-00)		PA5025 (x16) (50-319386-00) HR5048 ■ (24-319386-0/0)	N NC006 ■ (x2) 35x48x7mm, MVQ (50-319161-00) K NC065 ■ 30x40x7mm, FPM (50-306142-00) NB698 ■ 80x98x10mm, FPM (50-319273-00)			



KW/PS

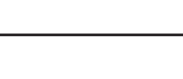

Frontera 2.0L i					03/92 → 10/98	130	BP820 (Fibre) (30-025819-10)	DP820 (21-25819-21/0)	EK482 (22-26131-01/0)
C 20 NE	1998	4	86.00	MPi, SOHC	85/115				
X 20 SE	1998	4	86.00	Injection, SOHC	85/115				
Frontera 2.2L DTI Diesel					10/98 → 09/02	131	AB5671 (MLS), 1.30mm, 1 Notch AB5681 (MLS), 1.40mm, 2 Notches	CB5670▲■ (21-29011-20/0) → Eng.2V599999 CB5671▲■ (21-29011-21/0) Eng.3V500001 →	EB5671 (22-29011-01/0)
X 22 DTH	2172	4	84.00	Direct Injection	85/115				
Y 22 DTH	2172	4	84.00	Direct Injection	85/88/ 92/115/ 120/ 125				
Frontera 2.2L i					03/95 → 10/98	132	BY250 (Fibre) (30-027987-10)	DY251 (21-27987-21/0)	EC100 (22-27206-01/0)
X 22 XE	2198	4	86.00	Injection, DOHC	100/136				
Frontera 2.2L i					10/98 →	133	BY250 (Fibre) (30-027987-10)	DY254 (21-27987-23/0) X22SE DY255 (21-27987-24/0) Y22SE	EC102 (22-27206-03/0)
Y 22 SE	2198	4	86.00	Injection, DOHC	100/136				
X 22 SE	2198	4	86.00	DOHC	100- 104/ 136- 141				
Frontera 2.3L TD Diesel					03/92 → 10/98	134	BR010 (Fibre), 1.30mm, 1 Hole (30-025657-10) BR020 (Fibre), 1.40mm, 2 Holes (30-025658-10) BR030 (Fibre), 1.50mm, 3 Holes (30-025659-10)		
23 DTR	2260	4	92.00	SOHC	74/100				
Frontera 2.4L i					03/92 → 10/98	135	BJ170 (Fibre) (30-025662-10)		
C 24 NE	2410	4	95.00	MPi	92/125				
Frontera 2.5L TDS Diesel					09/96 → 10/98	136	AY400 (MLS), 1.42mm, 0 Notches (30-028472-00) BK570 (Fibre), 1.42mm, 0 Notches (x4) (30-025008-20) AY410 (MLS), 1.52mm, 2 Notches (30-028473-00) BP260 (Fibre), 1.52mm, 2 Notches (x4) (30-025013-20) AY420 (MLS), 1.62mm, 1 Notch (30-028474-00) BK580 (Fibre), 1.62mm, 1 Notch (x4) (30-025007-20)	DK570▲ [7] (21-25850-21/0)	GK572▲ [8] (20-25850-01/0)
25 TDS (VM41B)	2500	4	92.00		85/116				
Frontera 2.8L TD Diesel					03/95 → 10/98	137	BR990 (MLS)	CD5400▲	ER993 GR991
28 TDI (4JB1T)	2771	4	93.00	OHV	83/113				

								
HBS003  (22-29009B) M11x1.25x140mm (x10) →12/96 HBS053  (22-29099B) M11x1.25x140mm (x10) 01/97→	JC756  (31-025820-20) JC282  (31-024625-20)  JE120 (31-024767-00)	JN693 [128] (31-026198-10)	JJ385 [148] (50-026131-00)	PA565 (x8) (50-305900-50) HR342  (24-30590-05/0)	 NC006  35x48x7mm, MVQ (50-319161-00)  NB700  31x50x8mm, FPM (50-306551-50)  NB806  90x104x11mm, FPM (50-306552-00)	NB807 [2] 	 AY400, AY410, AY420  BK570, BP260, BK580  BP820  BR010, BR020, BR030  BR990  BY250  JC282  JC756  JC928  JD025  JD187  JD451  JD5255  JD5256  JD5277  JD5347  JE120  JF123  JM5159  JN693 JN707	 JN923  JN924  JP016  JP067  JP068  JH5019  JJ385  JJ454  JJ459
HBS298  (22-29016B) M12x1.50x235mm (x10)	JD5255  (31-029721-00) JD5347  (31-029942-00) →Eng.2V599999 JD5277  (31-029723-00) Eng.3V500001 → JD5256  (31-029722-00)	JM5159 (50-029633-00)	HR791  24-30614-76/0	 NA5069  55x68x8mm, FPM (50-319151-00)  NA5209  99x114x11mm, FPM (50-319141-00)			 BR010, BR020, BR030  BR990  BY250  JC282  JC756  JC928  JD025  JD187  JD451  JD5255  JD5256  JD5277  JD5347  JE120  JF123  JM5159 JN693 JN707	
HBS054  (22-29013B) M11x1.25x105mm (x10)	JD451  (31-027699-00) JD450  (31-027684-00)	JP016 (50-027683-00)	JJ459 [148] (31-027206-00)	HR791  24-30614-76/0	 NC006  (x2) 35x48x7mm, MVQ (50-319161-00)  NB700  31x50x8mm, FPM (50-306551-50)  NB806  90x104x11mm, FPM (50-306552-00)		 JC282  JC756  JC928  JD025  JD187  JD451  JD5255  JD5256  JD5277  JD5347  JE120  JF123  JM5159 JN693 JN707	
HBS054  (22-29013B) M11x1.25x105mm (x10)	JD451  (31-027699-00) X225E JD5300  (31-027684-10) (MLS) X225E JD5737  (31-030118-00) (MLS)	JP016 (50-027683-00)	JH5096 (31-030122-00) (Steel Elastomer)	HR791  24-30614-76/0	 NC006  (x2) 35x48x7mm, MVQ (50-319161-00)  NB700  31x50x8mm, FPM (50-306551-50)  NB806  90x104x11mm, FPM (50-306552-00)		 JC282  JC756  JC928  JD025  JD187  JD451  JD5255  JD5256  JD5277  JD5347  JE120  JF123 JM5159 JN693 JN707	
HBS163  (22-29010B) M13x1.50x134mm (x10)	JD5765 (31-025415-10)		JH5019 (50-026493-00)	PA543 (x8) (50-305908-10) HR794  (24-30590-81/0)	 NB628  45x60x9mm, ACM (50-305272-00)  NB690  81x100.1x11.5mm, FPM (50-319087-00)		 JD5256  JD5277  JD5347  JE120  JF123  JM5159 JN693 JN707	
HBS161  (22-29007B) M12x1.50x64mm (x5) M12x1.50x97.5mm (x5)	JD187 (31-026476-10)	JN923 (50-026499-00) JN924 (x2)	JH5019  (50-026493-00)	HR336  (x2) (24-30656-05/0)	 NB628  45x60x9mm, ACM (50-305272-00)  NB469  77x100x11.5mm, FPM (50-306260-50)		 JD5256  JD5277  JD5347  JE120  JF123 JM5159 JN693 JN707	
HBS108  (22-56003B) M14x2.0x137mm (x10) M12x1.75x115mm (x4) M12x1.75x79.5mm (x4)	JC928  (x4) (31-025852-10) JD025  (x4) (31-025849-10)  JF123 (31-027523-00)	JP067 (31-025850-10) JP068 [9] (31-029626-00)					 JM5159  JN693  JN707	
HBS287  (22-20005B) M11x1.50x121mm (x18)	JD470  (31-029753-00)	JN707	HC5008 JJ454	PA418 (x8)	 NJ267 42x55x9mm, NBR  NJ014 50x68x9mm, NBR  NJ322 95x118x10mm, NBR		 JM5159  JN693 JN707	



KW/PS

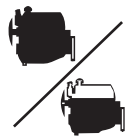

GT Cabriolet 2.0L 06/07 → 138								
LNF/Z 20 NHH	1998	4	86.00	Injection, DOHC	194/264			
Kadett 1.0L 01/74 → 07/79 139								ET820 (22-20159-02/0)
Kadett N 03/63 → 08/65								
10 N	993	4	72.00	OHV	29/40			
Kadett 1.1L 08/71 → 08/73 140								ET820 (22-20159-02/0)
11 N	1078	4	75.00	Injection	33-37/ 45-50			
Kadett 1.2L 08/71 → 08/73 141						BN040 (Fibre), 1.36mm (30-022712-20)		ET820 (22-20159-02/0)
Kadett 1.2L S 08/71 → 08/73								
Kadett Coupe 1.2L 08/71 → 08/73						BH860 (Fibre), 1.70mm (30-023271-20)		
12 S	1196	4	79.00	OHV	40-44/ 54-60			
Kadett 1.2L 08/73 → 07/82 142						BN040 (Fibre), 1.36mm (30-022712-20)	DN041 ■ (21-22712-26/0)	ET820 (22-20159-02/0)
Kadett Coupe 1.2L 08/73 → 07/79						BH860 (Fibre), 1.70mm (30-023271-20)		
12 N	1196	4	79.00	Carburettor, OHV	38-40/ 52-55			
Kadett 1.2L 08/82 → 08/84 143						BL550 (Fibre) (30-024666-10)	DL550 (21-24666-24/0)	EK470 (22-27194-05/0)
12 ST	1196	4	77.80	Carburettor, SOHC	40-43/ 55-58			
Kadett 1.2L 09/84 → 07/86 144						BN040 (Fibre), 1.36mm (30-022712-20)	DN041 ■ (21-22712-26/0)	ET820 (22-20159-02/0)
Kadett 1.2L S 08/79 → 08/84						BH860 (Fibre), 1.70mm (30-023271-20)	DN042 (21-22712-27/0)	
Kadett Van 1.2L 09/84 → 07/86								
12 SC	1196	4	79.00	OHV	40/54			
12 S	1196	4	79.00	OHV	40-44/ 54-60			
Kadett 1.2L 09/84 → 07/86 145						BN040 (Fibre), 1.36mm (30-022712-20)	DK470 (21-24033-26/0)	ET820 (22-20159-02/0)
Kadett 1.2L 09/84 → 07/86						BH860 (Fibre), 1.70mm (30-023271-20)	DN042 (21-22712-27/0)	
12 SC	1196	4	79.00	OHV	40/54			
Kadett 1.3L i 09/85 → 08/91 146						BK470 (Fibre) (30-024033-10)	DK470 (21-24033-26/0)	EK470 (22-27194-05/0)
Kadett 1.3L i 09/85 → 08/91						BH860 (Fibre), 1.70mm (30-023271-20)	→ 12/85	
C 13 N	1297	4	75.00	SPi, SOHC	44/60		DK471 (21-24033-30/0)	
Kadett 1.3L N 09/84 → 08/91 147						BK470 (Fibre) (30-024033-10)	DK470 (21-24033-26/0)	EK470 (22-27194-05/0)
Kadett Van 1.3L N 09/84 → 07/89							→ 12/86	GK470 (20-24033-01/0)
13 N	1297	4	75.00	SOHC	39-44/ 53-60		DK471 (21-24033-30/0)	
13 NB	1297	4	75.00	Carburettor, SOHC	44/60		01/87 →	
Kadett 1.3L S 09/84 → 12/89 148						BK470 (Fibre) (30-024033-10)	DK470 (21-24033-26/0)	EK470 (22-27194-05/0)
Kadett 1.3L S 09/84 → 12/89							→ Eng.13519417531	GK470 (20-24033-01/0)
13 S	1297	4	75.00	Injection, SOHC	42-55/ 57-75		DK471 (21-24033-30/0)	
Kadett 1.3L S 09/84 → 12/89							Eng.13519417532 →	

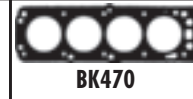
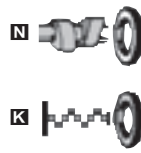
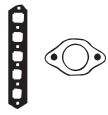

BK470



BL550



BNO40, BH860



JA415



JA499



JC280



JC281



JE119



JN068



JN344

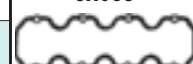

JN626

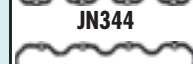

HC288



JH5005



JJ120

JD5867
(31-030343-00)
(Steel Elastomer)

HBS112
(22-29006B)
M9x1.25x80mm (x5)
M9x1.25x100mm (x5)

JA499
JA415
(31-020165-10)

JN068
(31-023120-10)

HC288
(23-20161-01/0)

HR291
(50-024209-00)

NB691 54x82x9mm, ACM

HBS112
(22-29006B)
M9x1.25x80mm (x5)
M9x1.25x100mm (x5)

JA499
JA415
(31-020165-10)

JN068
(31-023120-10)

HC288
(23-20161-01/0)

HR291
(50-024209-00)

NB691 54x82x9mm, ACM

HBS112
(22-29006B)
M9x1.25x80mm (x5)
M9x1.25x100mm (x5)

JA499
JA415
(31-020165-10)

HC288
(23-20161-01/0)

HR291
(50-024209-00)

NB691 54x82x9mm, ACM **NA380** [42]

HBS112
(22-29006B)
M9x1.25x80mm (x5)
M9x1.25x100mm (x5)

JA499
JA415
(31-020165-10)

JN068
(31-023120-10)

HC288
(23-20161-01/0)

HR291
(50-024209-00)

NB691 54x82x9mm, ACM **NB575** [2]

HBS002
(22-29098B)
M10x1.25x140mm (x10)

JC280
(31-024313-10)
JC281
(31-024312-10)

JN344
(31-024299-00)

JH5005 [116]
(31-027194-00)
JJ120

PA565 (x8)
(50-305900-50)
HR342
(24-30590-05/0)

NC006 35x48x7mm, MVQ
(50-319161-00)

NB697 26x42x8mm, FPM
(50-306704-00)

NB698 80x98x10mm, FPM
(50-319273-00)

NB575 [2]

HBS112
(22-29006B)
M9x1.25x80mm (x5)
M9x1.25x100mm (x5)

JA499
JA415
(31-020165-10)

JN068
(31-023120-10)

HC288
(23-20161-01/0)

HR291
(50-024209-00)

NC006 35x48x7mm, MVQ
(50-319161-00)

NB691 54x82x9mm, ACM

NB575 [2]

HBS112
(22-29006B)
M9x1.25x80mm (x5)
M9x1.25x100mm (x5)

JA499
JA415
(31-020165-10)

JN068
(31-023120-10)

HC288
(23-20161-01/0)

HR291
(50-024209-00)

NC006 35x48x7mm, MVQ
(50-319161-00)

NB691 54x82x9mm, ACM

NB575 [2]

HBS002
(22-29098B)
M10x1.25x140mm (x10)

JC280
(31-024313-10)
JC281
(31-024312-10)

JN344
(31-024299-00)
→12/85
JN626
(31-026099-10)
01/86→

JH5005 [116]
(31-027194-00)
JJ120

PA565 (x8)
(50-305900-50)
HR342
(24-30590-05/0)

NC006 35x48x7mm, MVQ
(50-319161-00)

NB697 26x42x8mm, FPM
(50-306704-00)

NB698 80x98x10mm, FPM
(50-319273-00)

NB575 [2]

HBS002
(22-29098B)
M10x1.25x140mm (x10)

JC280
(31-024313-10)
JC281
(31-024312-10)
 JE119
(31-024520-00)

JN344
(31-024299-00)
→12/86
JN626
(31-026099-10)
01/87→

JH5005 [116]
(31-027194-00)
JJ120

PA565 (x8)
(50-305900-50)
HR342
(24-30590-05/0)

NC006 35x48x7mm, MVQ
(50-319161-00)

NB697 26x42x8mm, FPM
(50-306704-00)

NB698 80x98x10mm, FPM
(50-319273-00)

NB575 [2]

HBS002
(22-29098B)
M10x1.25x140mm (x10)

JC280
(31-024313-10)
JC281
(31-024312-10)
 JE119
(31-024520-00)

JN344
(31-024299-00)
→Eng.1351941753
1
JN626
(31-026099-10)
Eng.1351941753
→

JH5005 [116]
(31-027194-00)
JJ120

PA565 (x8)
(50-305900-50)
HR342
(24-30590-05/0)

NC006 35x48x7mm, MVQ
(50-319161-00)

NB697 26x42x8mm, FPM
(50-306704-00)

NB698 80x98x10mm, FPM
(50-319273-00)







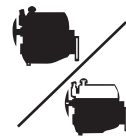



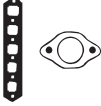

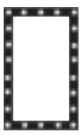

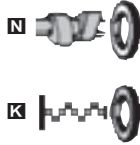











































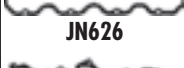

































NB575 [2]



KW/PS



Kadett Convertible 1.3L S		03/87 → 02/93		149		BK470 (Fibre) (30-024033-10)		DK471 (21-24033-30/0)		EK470 (22-27194-05/0) GK470 (20-24033-01/0)	
13 S	1297	4	75.00	Injection, SOHC	42-55/ 57-75						
Kadett 1.4L i		01/90 → 07/94		150		BS260 (Fibre) (30-026329-10)		DS260 (21-26329-21/0)		EK470 (22-27194-05/0)	
Kadett 1.4L S		07/89 → 08/91									
Kadett Convertible 1.4L i		01/90 → 08/91									
Kadett Convertible 1.4L S		08/90 → 02/93									
Kadett Van 1.4L i		01/90 → 08/91									
C 14 NZ	1389	4	77.60	SPi, SOHC	44/60						
14 NV	1389	4	77.60	Carburettor, SOHC	53-55/ 72-75						
Kadett 1.4L S		09/89 → 08/91		151		BS260 (Fibre) (30-026329-10)		DS261 (21-26329-22/0)		ES260 [248] (22-27194-00/0)	
C 14 SE	1389	4	77.60	MPi, SOHC	60/82						
Kadett 1.5L D Diesel		01/87 →		152		AY840 (MLS), 1.40mm (30-028998-00) AY900 (MLS), 1.40mm (30-029007-00) AY850 (MLS), 1.45mm, 1 Hole (30-028999-00) AY910 (MLS), 1.45mm, 1 Hole (30-029006-00) AY860 (MLS), 1.50mm, 2 Holes (30-029000-00) AY920 (MLS), 1.50mm, 2 Holes (30-029008-00)		CY811▲■ (21-27776-22/0)		FY811▲ (20-27776-02/0)	
15 D (4EC1)	1488	4	76.00	SOHC	37/50						
Kadett 1.5L TD Diesel		07/88 → 08/91		153		AY840 (MLS), 1.40mm (30-028998-00) →Eng.975024 AY850 (MLS), 1.45mm, 1 Hole (30-028999-00) →Eng.975024 AY860 (MLS), 1.50mm, 2 Holes (30-029000-00) →Eng.975024 AY900 (MLS), 1.40mm (30-029007-00) Eng.975025→ AY910 (MLS), 1.45mm, 1 Hole (30-029006-00) Eng.975025→ AY920 (MLS), 1.50mm, 2 Holes (30-029008-00) Eng.975025→		CY811▲■ (21-27776-22/0)		FY811▲ (20-27776-02/0)	
15 DT (T4EC1)	1488	4	76.00	SOHC	49-53/ 67-72						
Kadett 1.6L		01/81 → 12/86		154		BK480 (Fibre) (30-024578-10)		DK480 (21-24578-22/0)			
1.6N/S	1598	4	80.00	SOHC							











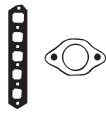

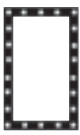

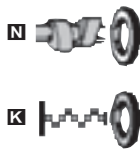



































































































								
HBS002  (22-29098B) M10x1.25x140mm (x10)	JC280  (31-024313-10) JC281  (31-024312-10)  JE119 (31-024520-00)	JN626 (31-026099-10)	JH5005 [116] (31-027194-00) JJ120	PA565 (x8) (50-305900-50) HR342  (24-30590-05/0)	 NCO06  35x48x7mm, MVQ (50-319161-00)  NB697  26x42x8mm, FPM (50-306704-00)  NB698  80x98x10mm, FPM (50-319273-00)	NB575 [2] 	 AY840, AY850, AY860  JH5058  AY900, AY910, AY920  JJ120  BK470  JJ200	
HBS002  (22-29098B) M10x1.25x140mm (x10)	JC824  (31-026334-00) JC281  (31-024312-10)	JN626 (31-026099-10)	JH5005 [116] (31-027194-00) JJ120	PA565 (x8) (50-305900-50) HR342  (24-30590-05/0)	 NCO06  35x48x7mm, MVQ (50-319161-00)  NB697  26x42x8mm, FPM (50-306704-00)  NB698  80x98x10mm, FPM (50-319273-00)	NB575 [2] 	 BK480  BS260  JC280  JC281  JC282  JC283  JC823  JC824  JD303  JD304  JE119  JE120  JN453  JN626  JN777  JN929  JH5005	
HBS002  (22-29098B) M10x1.25x140mm (x10)	JC823  (31-027191-10) JC281  (31-024312-10)	JN929 (50-027192-10)	JH5005 [116] (31-027194-00) JJ120	PA565 (x8) (50-305900-50) HR342  (24-30590-05/0)	 NCO06  35x48x7mm, MVQ (50-319161-00)  NB697  26x42x8mm, FPM (50-306704-00)  NB698  80x98x10mm, FPM (50-319273-00)	NB575 [2] 		
HBS036  (22-29001B) M12x1.5x102mm (x10)	JD303  JD304 	JN776 JN777 (50-027776-00)	JH5058 (31-027781-00)	PA658 (x8) (50-319265-00)	 NJ449  40x52x6mm, NBR (50-319266-00)  NJ449  40x52x6mm, NBR (50-319266-00)  NK103  87x100x8.5mm, FPM			
HBS036  (22-29001B) M12x1.5x102mm (x10)	JD303  JD5914  (31-027778-00) JD304 	JN776 →12/89 JN777 (50-027776-00) 01/90 →	JH5058 (31-027781-00)	PA658 (x8) (50-319265-00)	 NJ449  40x52x6mm, NBR (50-319266-00)  NJ449  40x52x6mm, NBR (50-319266-00)  NK103  87x100x8.5mm, FPM			
HBS003  (22-29009B) M11x1.25x140mm (x10)	JC283  (31-025183-10) JC282  (31-024625-20)  JE120 (31-024767-00)	JN453 [127] (31-024572-00)	JJ200 (31-025011-00)	HR343  (24-30602-50/0)	 NCO06  35x48x7mm, MVQ (50-319161-00)  NB700  31x50x8mm, FPM (50-306551-50)  NB701  86x104x11mm, FPM (50-306261-50)	NB575 [2]		



KW/PS



Kadett 1.6L 09/86 → 12/91 155						BP800 (Fibre) (30-025706-20)	DP800 (21-25706-26/0)	EK484 [129] (22-27194-01/0)
Kadett 1.6L S 09/86 → 08/91								
Kadett Convertible 1.6L i 07/89 → 02/93								
16 SV	1598	4	79.00	Carburettor, SOHC	60/82			
Kadett 1.6L D Diesel 09/84 → 01/89 156						BLO10 (Fibre), 1.40mm (30-025124-10) → 0.75mm BLO20 (Fibre), 1.50mm, 1 Notch (30-025125-10) → 0.75 → 0.85mm BLO30 (Fibre), 1.60mm, 2 Notches (30-025126-10) → 0.85mm →	DL010 ▲ (25-24572-02/0) → 12/85 DL011 ▲ (21-26198-20/0) 01/86 →	EK481 (22-25011-00/0) → 12/85 EK485 (22-25011-04/0) 01/86 →
Kadett Van 1.6L D Diesel 08/84 → 08/88								
16 D/16 DA	1598	4	80.00	SOHC	40/54			
Kadett 1.6L D Diesel 01/86 → 12/89 157						BLO10 (Fibre), 1.40mm (30-025124-10) → 0.75mm BLO20 (Fibre), 1.50mm, 1 Notch (30-025125-10) → 0.75 → 0.85mm BLO30 (Fibre), 1.60mm, 2 Notches (30-025126-10) → 0.85mm →	DL011 ▲ (21-26198-20/0)	EK485 (22-25011-04/0)
16 DA								
16 DA	1598	4	80.00	SOHC	40/54			
Kadett 1.6L i 09/86 → 07/94 158						BP800 (Fibre) (30-025706-20)	DP802 (21-25706-25/0)	EK484 [129] (22-27194-01/0)
Kadett Convertible 1.6L i 10/86 → 02/93								
Kadett Van 1.6L i 08/89 → 09/93								
C 16 LZ/ C 16 NZ/E 16 NZ	1598	4	79.00	SPi, SOHC	55/75			
Kadett 1.6L S 09/84 → 08/86 159						BK480 (Fibre) (30-024578-10)	DK480 (21-24578-22/0)	
16 SH	1598	4	80.00	SOHC	66/89			
Kadett 1.7L D Diesel 01/89 → 07/94 160						BY330 (Fibre), 1.30mm (30-027492-10) BY340 (Fibre), 1.40mm, 1 Notch (30-027493-10) BY350 (Fibre), 1.50mm, 2 Notches (30-027494-10)	DL011 ▲ (21-26198-20/0)	EK485 (22-25011-04/0)
Kadett Van 1.7L D Diesel 08/88 → 09/92								
17 D 17 DR	1699 1699	4 4	82.50 82.50	SOHC SOHC	42/57 42-44/ 57-60			
Kadett 1.8L 09/87 → 08/90 161						BP810 (Fibre) (30-025818-10)	DP811 (21-25818-23/0)	EK482 (22-26131-01/0)
18 E	1796	4	84.80	MPi, SOHC	82-85/ 112- 115			







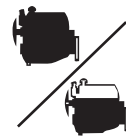



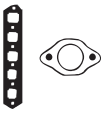

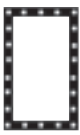















								
HBS002  (22-29098B) M10x1.25x140mm (x10)	JC824  (31-026334-00) JC281  (31-024312-10)  JE120 (31-024767-00)	JN626 (31-026099-10)	JH5005 (x2) [116] (31-027194-00) JJ120 (x2)	PA565 (x8) (50-305900-50) HR342  (24-305900-05/0)	 NC006  35x48x7mm, MVQ (50-319161-00)  NB697  26x42x8mm, FPM (50-306704-00)  NB698  80x98x10mm, FPM (50-319273-00)	NB575 [2] 	 BK480  BL010, BL020, BL030  BP800  BP810  BY330, BY340, BY350  JC281  JC282  JC283  JC436  JC437  JC756  JC824  JE119  JE120  JN453  JN626  JN693  JH5005	 JJ120  JJ200  JJ385
HBS074  (22-29100B) M11x1.25x154mm (x10)	JC436  (31-028012-00) JC437  (31-024854-10)  JE119 (31-024520-00)	JN453 [127] (31-024572-00) →12/85 JN693 [128] (31-026198-10) 01/86 →	JJ200 (31-025011-00)	HR343  (24-30602-50/0)	 NC006  35x48x7mm, MVQ (50-319161-00)  NB734  35x50x8mm, FPM  NB701  86x104x11mm, FPM (50-306261-50) →12/85  NB806  90x104x11mm, FPM (50-306552-00) 01/86 →	NB575 [2] 		
HBS074  (22-29100B) M11x1.25x154mm (x10)	JC436  (31-028012-00) JC437  (31-024854-10)  JE119 (31-024520-00)		JJ200 (31-025011-00)	HR343  (24-30602-50/0)	 NC006  35x48x7mm, MVQ (50-319161-00)  NB734  35x50x8mm, FPM  NB806  90x104x11mm, FPM (50-306552-00)	NB575 [2] 		
HBS002  (22-29098B) M10x1.25x140mm (x10)	JC824  (31-026334-00) JC281  (31-024312-10)	JN626 (31-026099-10)	JH5005 (x2) [116] (31-027194-00) JJ120 (x2)	PA565 (x8) (50-305900-50) HR342  (24-305900-05/0)	 NC006  35x48x7mm, MVQ (50-319161-00)  NB697  26x42x8mm, FPM (50-306704-00)  NB698  80x98x10mm, FPM (50-319273-00)	NB575 [2] 		
HBS003  (22-29009B) M11x1.25x140mm (x10)	JC283  (31-025183-10) JC282  (31-024625-20)  JE120 (31-024767-00)	JN453 [127] (31-024572-00)	JJ200 (31-025011-00)	HR343  (24-30602-50/0)	 NC006  35x48x7mm, MVQ (50-319161-00)  NB700  31x50x8mm, FPM (50-306551-50)  NB701  86x104x11mm, FPM (50-306261-50) →12/85  NB806  90x104x11mm, FPM (50-306552-00) 01/86 →	NB575 [2] 		
HBS074  (22-29100B) M11x1.25x154mm (x10)	JC436  (31-028012-00) JC437  (31-024854-10)  JE119 (31-024520-00)	JN693 [128] (31-026198-10)	JJ200 (31-025011-00)	HR343  (24-30602-50/0)	 NC006  35x48x7mm, MVQ (50-319161-00)  NB734  35x50x8mm, FPM  NB806  90x104x11mm, FPM (50-306552-00)	NB575 [2] 		
HBS003  (22-29009B) M11x1.25x140mm (x10)	JC756  (31-025820-20) JC282  (31-024625-20)  JE120 (31-024767-00)	JN693 [128] (31-026198-10)	JJ385 (x2) [148] (50-026131-00)	PA565 (x8) (50-305900-50) HR342  (24-305900-05/0)	 NC006  35x48x7mm, MVQ (50-319161-00)  NB700  31x50x8mm, FPM (50-306551-50)  NB806  90x104x11mm, FPM (50-306552-00)	NB575 [2] 		



KW/PS



Kadett 1.8L E 10/85 → 08/86 162						BM380 (Fibre) (30-024765-10)	DM381 (21-24765-23/0)			
Kadett 1.8L GSI 09/84 → 08/86										
Kadett 1.8L i 09/84 → 08/86										
Kadett Van 1.8L i 08/84 → 09/92										
C 18 NT	1796	4	84.80	Injection, SOHC	66/89					
C 18 NE	1796	4	84.80	Injection, SOHC	74/100					
18 E	1796	4	84.80	MPi, SOHC	82-85/ 112- 115					
Kadett 1.8L i 06/85 → 08/91 163						BM380 (Fibre) (30-024765-10) C18NT BP810 (Fibre) (30-025818-10) C18NZ, S18NV	DM381 (21-24765-23/0) C18NT DP810 (21-25818-22/0) C18NZ, S18NV	EK482 (22-26131-01/0) C18NZ, S18NV		
S 18 NV	1796	4	84.80	Injection, SOHC	62-74/ 84-101					
C 18 NT	1796	4	84.80	Injection, SOHC	66/89					
C 18 NZ	1796	4	84.80	SPi, SOHC	66/90					
Kadett 1.8L i 06/85 → 08/91 164						BM380 (Fibre) (30-024765-10) C18NT BP810 (Fibre) (30-025818-10) C18NZ	DM381 (21-24765-23/0) C18NT DP810 (21-25818-22/0) C18NZ	EK482 (22-26131-01/0) C18NZ		
C 18 NT	1796	4	84.80	Injection, SOHC	66/89					
C 18 NZ	1796	4	84.80	SPi, SOHC	66/90					
Kadett 1.8L S 09/87 → 08/91 165						BP810 (Fibre) (30-025818-10)	DP810 (21-25818-22/0)	EK482 (22-26131-01/0)		
E 18 NV	1796	4	84.80	Carburettor, SOHC	62/84					
S 18 NV	1796	4	84.80	Injection, SOHC	62-74/ 84-101					
Kadett 2.0L 01/85 → 12/92 166						BP820 (Fibre) (30-025819-10)	DP820 (21-25819-21/0)	EK482 (22-26131-01/0)		
Kadett 2.0L GSI 09/86 → 08/91										
Kadett 2.0L i 03/87 → 08/91										
Kadett Convertible 2.0L i 10/86 → 02/93										
20 NE/C 20 NE	1998	4	86.00	MPi, SOHC	85/115					
20 SEH	1998	4	86.00	MPi, SOHC	95/129					
Kadett 2.0L GSI 16V 12/87 → 08/91 167						BS720 (Fibre) (30-026310-10)	DS720 (21-26310-22/0)	ES720 (22-27206-00/0)		
20 XEJ	1984	4	86.00	MPi, DOHC	110/150					
20 XE	1998	4	86.00	MPi, DOHC	115/156					
Kadett 2.0L GSI 16V 03/88 → 08/91 168						BS720 (Fibre) (30-026310-10)	DS720 (21-26310-22/0)	ES720 (22-27206-00/0)		
C 20 XE	1998	4	86.00	MPi, DOHC	110/150					











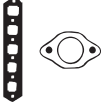

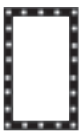

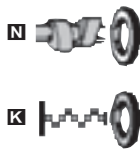























								
HBS003 (22-29009B) M11x1.25x140mm (x10)	JC283 (31-025183-10) JC282 (31-024625-20)  JE120 (31-024767-00)	JN453 [127] (31-024572-00)	JJ200 (31-025011-00)	HR343 (24-30602-50/0)	NCO06 (50-319161-00) NB700 (50-306551-50) NB701 (50-306261-50)	NB575 [2]		 BM380  BP810  BP820  BS720  JC282  JC283  JC756  JC757  JD430  JD455  JE120  JM950  JN453  JN693  JJ200  JJ385  JJ459
HBS003 (22-29009B) M11x1.25x140mm (x10)	JC283 (31-025183-10) C18NT JC757 (31-025817-10) C18NZ, S18NV JC282 (31-024625-20)  JE120 (31-024767-00)	JN453 [127] (31-024572-00) C18NT JN693 [128] (31-026198-10) C18NZ, S18NV	JJ200 (31-025011-00) C18NT JJ385 [148] (50-026131-00) C18NZ, S18NV	PA565 (x8) (50-305900-50) C18NZ, S18NV HR342 (24-30590-05/0) C18NZ, S18NV HR343 (24-30602-50/0) C18NT	NCO06 (50-319161-00) NB700 (50-306551-50) NB701 (50-306261-50) →12/85 NB806 (50-306552-00) 01/86 →	NB575 [2]		
HBS003 (22-29009B) M11x1.25x140mm (x10)	JC283 (31-025183-10) C18NT JC757 (31-025817-10) C18NZ JC282 (31-024625-20)  JE120 (31-024767-00)	JN453 [127] (31-024572-00) C18NT JN693 [128] (31-026198-10) C18NZ	JJ200 (31-025011-00) C18NT JJ385 [148] (50-026131-00) C18NZ	PA565 (x8) (50-305900-50) C18NZ HR342 (24-30590-05/0) C18NZ HR343 (24-30602-50/0) C18NT	NCO06 (50-319161-00) NB700 (50-306551-50) NB701 (50-306261-50) →12/85 NB806 (50-306552-00) 01/86 →	NB575 [2]		
HBS003 (22-29009B) M11x1.25x140mm (x10)	JC757 (31-025817-10) JC282 (31-024625-20)  JE120 (31-024767-00)	JN693 [128] (31-026198-10)	JJ385 [148] (50-026131-00)	PA565 (x8) (50-305900-50) HR342 (24-30590-05/0)	NCO06 (50-319161-00) NB700 (50-306551-50) NB806 (50-306552-00)	NB575 [2]		
HBS003 (22-29009B) M11x1.25x140mm (x10)	JC756 (31-025820-20) JC282 (31-024625-20)  JE120 (31-024767-00)	JN693 [128] (31-026198-10)	JJ385 [148] (50-026131-00)	PA565 (x8) (50-305900-50) HR342 (24-30590-05/0)	NCO06 (50-319161-00) NB700 (50-306551-50) NB806 (50-306552-00)	NB575 [2] NB807 [2]		
HBS035 (22-29005B) M11x1.25x110mm (x10) →Eng.14137011 HBS054 (22-29013B) M11x1.25x105mm (x10) Eng.14137012 →	JD455 (31-026335-10) JD430 (31-025888-00)	JM950 (50-026336-10)	JJ459 (x2) [148] (31-027206-00)	PA565 (x16) (50-305900-50) HR342 (x2) (24-30590-05/0)	NCO06 (x2) (50-319161-00) NB884 (50-319010-00) NB806 (50-306552-00)	NB575 [2]		
HBS035 (22-29005B) M11x1.25x110mm (x10) →Eng.14003804 HBS054 (22-29013B) M11x1.25x105mm (x10) Eng.14003805 →	JD455 (31-026335-10) JD430 (31-025888-00)	JM950 (50-026336-10)	JJ459 (x2) [148] (31-027206-00)	PA565 (x16) (50-305900-50) HR342 (x2) (24-30590-05/0)	NCO06 (x2) (50-319161-00) NB884 (50-319010-00) NB806 (50-306552-00)	NB575 [2] NB807 [2]		



KW/PS



Model						Year Range	Power (KW/PS)	Engine Code	Notes	Accessories
Kadett Coupe 2.0L E Rallye						08/77 → 07/79	169	BJ170 (Fibre)		
Kadett Coupe 2.0L GT/E						08/77 → 07/79		(30-025662-10)		
20 E	1979	4	95.00	MPI, CIH	81/110					
20 EH	1979	4	95.00	L-Jetronic, CIH	85/115					
Manta 1.2L N						08/76 → 07/83	170	BN040 (Fibre), 1.36mm	DN041 ■	ET820
Manta 1.2L S						09/75 → 02/79		(30-022712-20)	(21-22712-26/0)	(22-20159-02/0)
12 N	1196	4	79.00	Carburettor, OHV	38-40/ 52-55		BH860 (Fibre), 1.70mm			
12 S	1196	4	79.00	OHV	40-44/ 54-60		(30-023271-20)			
Manta Coupe 1.2L						04/72 → 08/75	171	BN040 (Fibre), 1.36mm	DH860 ■	ET820
12 S	1196	4	79.00	OHV	40-44/ 54-60		(30-022712-20)	(21-23271-21/0)	(22-20159-02/0)	
							BH860 (Fibre), 1.70mm	→ 12/73		
							(30-023271-20)	DN041 ■		
								(21-22712-26/0)		
								01/74 →		
Manta 1.3L S						08/79 → 08/86	172	BK470 (Fibre)	DK470	EK470
13 S	1297	4	75.00	Injection, SOHC	42-55/ 57-75		(30-024033-10)	(21-24033-26/0)	(22-20194-05/0)	
									GK470	
									(20-24033-01/0)	
Manta 1.8L S						07/82 → 08/87	173	BM380 (Fibre)	DM380	EK482
18 S	1796	4	84.80	Carburettor, SOHC	65-66/ 88-90		(30-024765-10)		(22-26131-01/0)	
									01/86 →	
Manta 2.0L						08/77 → 12/80	174	BJ170 (Fibre)		
Manta 2.0L E						08/77 → 08/88		(30-025662-10)		
Manta 2.0L S						08/77 → 08/84				
20 N	1979	4	95.00	Injection, CIH	56-66/ 76-90					
20 S	1979	4	95.00	Carburettor, CIH	74/100					
20 E	1979	4	95.00	MPI, CIH	81/110					
Meriva 1.3L CDTI Diesel						09/03 →	175		CD5810 ▲	ED5810
Z 13 DTJ	1248	4	69.60	Direct Injection	55/75				FD5810	
Meriva 1.4L 16V Twinport						07/04 →	176	AH5030 (MLS)	CH5030	
Z 14 XEP	1364	4	73.40	Injection, DOHC	66/89		(30-030366-00)	(21-30366-00/0)		
Meriva 1.6L						01/06 →	177	AE5930 (MLS)	CE5930	
Z 16 XEP	1598	4	79.00	Injection, DOHC	74-77/ 101- 105		(30-029999-00)	(21-29999-20/0)		
Meriva 1.6L						05/03 →	178	AE5920 (Steel)	CE5920	EB5541 [8]
Z 16 SE	1598	4	79.00	Injection, SOHC	62/84		(30-029996-00)	(21-29996-20/0)	(22-27665-03/0)	











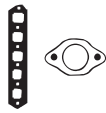

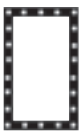

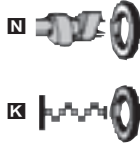





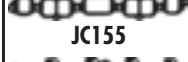
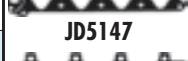



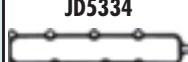
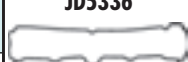

								
HBS161 ® (22-29007B) M12x1.50x64mm (x5) M12x1.50x97.5mm (x5)	JC155 (31-021058-20)	JN041 (31-022926-10)	HC417 ® (23-21237-01/0)	HR336 ® (24-30656-05/0)	NB628 ® 45x60x9mm, ACM (50-305272-00) NB469 ® 77x100x11.5mm, FPM (50-306260-50)	NB575 [2]®	 AE5920  JN344  AE5930  JN453  BK470  JN929  BM380  HC288  BN040, BH860  HC417  JA415  JA499  JH5005  JC155  JH5036  JC280  JC281  JJ120  JC282  JJ200  JC283  JJ385  JD5398  JD5399  JD5400  JD5401  JE119  JE120  JE5024  JM5235  JN041  JN068	
HBS112 ⊕ (22-29006B) M9x1.25x80mm (x5) M9x1.25x100mm (x5)	JA499 ■ JA415 ® (31-020165-10)	JN068 (31-023120-10)	HC288 ® (23-20161-01/0)	HR291 ® (50-024209-00)	NB691 ® 54x82x9mm, ACM (50-024209-00)	NB575 [2]® NA380 [42]®		
HBS112 ⊕ (22-29006B) M9x1.25x80mm (x5) M9x1.25x100mm (x5)	JA499 ■ JA415 ® (31-020165-10)	JN068 (31-023120-10) 01/74 →	HC288 ® (23-20161-01/0)	HR291 ® (50-024209-00)	NB691 ® 54x82x9mm, ACM (50-024209-00)	NB575 [2]® NA380 [42]®		
HBS002 ⊕ (22-29098B) M10x1.25x140mm (x10)	JC280 ■ (31-024313-10) JC281 ® (31-024312-10) ⊕ JE119 (31-024520-00)	JN344 (31-024299-00)	JH5005 [116] (31-027194-00) JJ120	PA565 (x8) (50-305900-50) HR342 ® (24-30590-05/0)	NC006 ® 35x48x7mm, MVQ (50-319161-00) NB697 ® 26x42x8mm, FPM (50-306704-00) NB698 ® 80x98x10mm, FPM (50-319273-00)	NB575 [2]®		
HBS003 ⊕ (22-29009B) M11x1.25x140mm (x10)	JC283 ■ (31-025183-10) JC282 ® (31-024625-20) ⊕ JE120 (31-024767-00)	JN453 [127] (31-024572-00)	JJ200 (31-025011-00) →12/85 JJ385 [148] (50-026131-00) 01/86 →	HR343 ® (24-30602-50/0)	NC006 ® 35x48x7mm, MVQ (50-319161-00) NB700 ® 31x50x8mm, FPM (50-306551-50) NB701 ® 86x104x11mm, FPM (50-306261-50) →12/85 NB806 ® 90x104x11mm, FPM (50-306552-00) 01/86 →	NB575 [2]®		
HBS161 ® (22-29007B) M12x1.50x64mm (x5) M12x1.50x97.5mm (x5)	JC155 (31-021058-20)	JN041 (31-022926-10)	HC417 ® (23-21237-01/0)	HR336 ® (24-30656-05/0)	NB628 ® 45x60x9mm, ACM (50-305272-00) NB469 ® 77x100x11.5mm, FPM (50-306260-50)	NB575 [2]®		
HBS252 ⊕ (22-29014B) M8x1.25x119mm (x12)	JD5904 ■ (x4) (50-030368-00) (FPM) JE5024 ® (31-029170-00)	JM5071 (50-029232-00)	JH5036 (31-029169-00)	HR5048 ® (24-31938-60/0)	NA5108 ® 42x55x7mm, FPM (50-319392-00) NB698 ® 80x98x10mm, FPM (50-319273-00)	JR5030 [11]		
HBS055 ⊕ (22-29012B) M10x1.25x153mm (x10)	JD5400 ■ (31-030002-00) JD5401 ® (31-030004-00)	JM5235 (50-029985-00)		HR5087 ® (24-31951-90/0)	NC006 ® (x2) 35x48x7mm, MVQ (50-319161-00) NA5174 ® 31.5x42x7mm, FPM (50-319469-00) NB698 ® 80x98x10mm, FPM (50-319273-00)			
HBS002 ⊕ (22-29098B) M10x1.25x140mm (x10)	JD5398 ■ (31-029997-00) JD5399 ® (31-029998-00)	JN929 (50-027192-10)		PA565 (x8) (50-305900-50) HR342 ® (24-30590-05/0)	NC006 ® (x2) 35x48x7mm, MVQ (50-319161-00) NB697 ® 26x42x8mm, FPM (50-306704-00) NB698 ® 80x98x10mm, FPM (50-319273-00)			



KW/PS

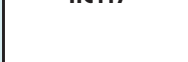
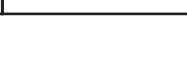

Meriva 1.6L 16V				05/03 →	179	AB5540 (MLS) (30-029209-00)	CB5540 (21-29209-20/0)	EB5541 [8] (22-27665-03/0)
Z 16 XE	1598	4	79.00	MPI, DOHC	74/100			
Meriva 1.7L CDTI Diesel				09/03 →	180	AE5520 (MLS), 1.45mm, 1 Hole (30-029904-00) AE5530 (MLS), 1.50mm, 2 Holes (30-029905-00) AE5540 (MLS), 1.55mm, 3 Notches (30-029906-00)	CE5523▲ (21-29904-23/0)	EE5520 (22-29904-00/0)
Z 17 DTH	1686	4	79.00	Direct Injection, DOHC	74/100			
Meriva 1.7L DTI Diesel				09/03 →	181	AE5520 (MLS), 1.45mm, 1 Hole (30-029904-00) AE5530 (MLS), 1.50mm, 2 Holes (30-029905-00) AE5540 (MLS), 1.55mm, 3 Notches (30-029906-00)	CE5521▲ (21-29904-21/0)	EE5520 (22-29904-00/0)
Y 17 DT	1686	4	79.00	Direct Injection, DOHC	55/75			
Meriva 1.8L				05/03 →	182	AC5460 (MLS) (30-028674-00)	CC5460 (21-28674-20/0)	
Z 18 XE	1796	4	80.50	MPI, DOHC	92/125			
Monterey 3.0L DTI Diesel				07/98 →08/99	183	AG5090 (MLS), 1.25mm, 3 Holes	CG5090▲	
4 JX1	2999	4	95.40	Direct Injection, DOHC	117- 118/ 159- 160			
Monterey 3.1L TD Diesel				09/91 →07/98	184	AG7720 (Steel), 1.6mm, 1 Notch AG7730 (Steel), 1.65mm, 2 Notches AD5400 (Fibre), 1.7mm, 3 Holes	CD5400▲	ER993
4JG2TC	3059	4	93.00	OHV	84/114			
Monterey 3.2L				06/92 →07/98	185	AG5080 (Fibre), 1.2mm	CG5500	EG6240
6VD1	3165	6	93.40	MPI, DOHC, V6	130/177			
Monza Coupe 2.0L E				03/83 →10/84	186	BJ170 (Fibre) (30-025662-10)		
H 20 E	1979	4	95.00	MPI	85/115			
Monza Coupe 2.2L E				11/84 →08/86	187	BJ170 (Fibre) (30-025662-10)	DJ172 (21-25662-27/0)	
22 E	2197	4	95.00	Injection, CIH	85/115			
Monza Coupe 2.5L E				05/81 →08/86	188	BT530 (Fibre) (30-026239-10)		
H 25 E	2490	6	87.00	L-Jetronic, CIH	100/136			
Monza Coupe 2.5L E				06/84 →08/86	189	BT530 (Fibre) (30-026239-10)		EW870 (22-21235-00/0)
25 E	2490	6	87.00	L-Jetronic, CIH	96-103/ 130- 140			







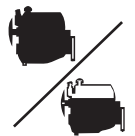



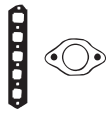

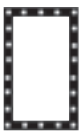

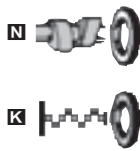









								
HBS055 ® (22-29012B) M10x1.25x153mm (x10)	JD5147 ■ (31-029203-00) JD5148 ■ (31-029204-00)	JM5059 (50-029202-00)		HR791 ■ 24-30614-76/0	NC006 ■ (x2) 35x48x7mm, MVQ (50-319161-00) NB697 ■ 26x42x8mm, FPM (50-306704-00) NB698 ■ 80x98x10mm, FPM (50-319273-00)			 AB5540  AC5460  AE5520, AE5530, AE5540
HBS036 ® (22-29001B) M12x1.5x102mm (x10)	JD5334 ■ (31-029914-00) JD5331 ■ (x2) (31-029911-00)	JM5198 (50-029908-00)		HR791 ■ 24-30614-76/0	NB884 38x50x5.5mm, FPM (50-319010-00) NJ449 ■ 40x52x6mm, NBR (50-319266-00) NK103 ■ 87x100x8.5mm, FPM			 BT530  JC155  JD5147  JD5148
HBS036 ® (22-29001B) M12x1.5x102mm (x10)	JD5332 ■ (31-029912-00) →Eng.721439 JD5333 ■ (31-029913-00) Eng.721439 → JD5336 ■ □ (31-029916-00) Eng.721439 → JD5329 ■ (31-029909-00)	JM5197 (50-029907-00)		HR791 ■ 24-30614-76/0	NB884 38x50x5.5mm, FPM (50-319010-00) NJ449 ■ 40x52x6mm, NBR (50-319266-00) NK103 ■ 87x100x8.5mm, FPM			 JD5196  JD5197  JD5329  JD5331  JD5332  JD5334  JD5336
HBS055 ® (22-29012B) M10x1.25x153mm (x10)	JD5196 ■ (31-029039-00) JD5197 ■ (31-029040-00)	JM5092 (50-029087-00)		PA5025 (x16) (50-319386-00) HR5048 ■ (24-31938-60/0)	NC006 ■ (x2) 35x48x7mm, MVQ (50-319161-00) NC065 ■ 30x40x7mm, FPM (50-306142-00) NB698 ■ 80x98x10mm, FPM (50-319273-00)			 JD5331  JD5332  JD5334  JD5336
HBS419 (22-29027B) M11x1.50x110mm (x18)								 JM5059  JM5092
HBS287 ⊕ (22-20005B) M11x1.50x121mm (x18)			HC5008 ■ JJ555					 JM5059  JM5092
HBS161 ® (22-29007B) M12x1.50x64mm (x5) M12x1.50x97.5mm (x5)	JC155 (31-021058-20)	JN041 (31-022926-10)	HC417 ■ (23-21237-01/0)	HR336 ■ (24-30656-05/0)	NB628 ■ 45x60x9mm, ACM (50-305272-00) NB469 ■ 77x100x11.5mm, FPM (50-306260-50)	NB575 [2]■		 JM5092  JM956  JN041
HBS161 ® (22-29007B) M12x1.50x64mm (x5) M12x1.50x97.5mm (x5)		JN041 (31-022926-10)	HC417 ■ (23-21237-01/0)	HR336 ■ (24-30656-05/0)	NB628 ■ 45x60x9mm, ACM (50-305272-00) NB469 ■ 77x100x11.5mm, FPM (50-306260-50)	NB575 [2]■		 JM956 JN041
		JM956 (31-022399-10) →Eng.25E45754 JN694 (50-026098-00) Eng.25E45755 →	HC295 ■ (23-21243-01/0)	HR336 ■ (x3) (24-30656-05/0)	NB628 ■ 45x60x9mm, ACM (50-305272-00) NB469 ■ 77x100x11.5mm, FPM (50-306260-50)			 JN694 HC295 HC417
		JM956 (31-022399-10) →Eng.25E45754 JN694 (50-026098-00) Eng.25E45755 →	HC295 ■ (23-21243-01/0)	HR336 ■ (x3) (24-30656-05/0)	NB628 ■ 45x60x9mm, ACM (50-305272-00) NB469 ■ 77x100x11.5mm, FPM (50-306260-50)			 HC295 HC417



KW/PS



Movano 1.9L DTI Diesel				09/00 → 10/01		190			CC5060▲	EC5060
F9Q 770	1870	4	80.00	Direct Injection, SOHC	59/80	AC5070 (Fibre), 1.35mm, 2 Notches (30-029474-00) →0.653mm AC5080 (Fibre), 1.45mm, 1 Notch (30-029475-00) →0.653→0.786mm AC5090 (Fibre), 1.55mm, 3 Notches (30-029476-00) →0.786mm→		(21-29483-20/0)	(22-29474-00/0)	
Movano 1.9L DTI Diesel				10/01 →		191			CC5060▲	EC5060
F9Q 774	1870	4	80.00	Direct Injection	60/81	AC5070 (Fibre), 1.35mm, 2 Notches (30-029474-00) →0.653mm AC5080 (Fibre), 1.45mm, 1 Notch (30-029475-00) →0.653→0.786mm AC5090 (Fibre), 1.55mm, 3 Notches (30-029476-00) →0.786mm→		(21-29483-20/0)	(22-29474-00/0)	
Movano 2.2L DTI Diesel				09/00 →		192			CE5210	EE5220
G9T 720	2188	4	87.00	Direct Injection, DOHC	66/89	AE5210 (MLS), 1.24mm (30-029250-00)			(22-29037-00/0) G9T-720	
Movano 2.5L D Diesel				07/98 → 09/00		193			DE588▲ [109]	FY291▲ [12]
S8U 770	2499	4	93.00		59/80	AY290 (Fibre), 1.60mm [112] (30-027426-00) AY300 (Fibre), 1.70mm [112] (30-026654-20) AY310 (Fibre), 1.80mm [112] (30-026655-20)		(21-26037-23/0)	(20-27426-00/0)	
Movano 2.5L DTI Diesel				10/01 →		194			EE5220	EE5220
G9U 754	2463	4	89.00	Direct Injection, DOHC	84-73/ 115-99	AE5220 (MLS) (30-029037-00)			(22-29037-00/0) G9U-720/724	
G9U 720	2463	4	89.00	Direct Injection, DOHC	85/116					
Movano 2.8L Diesel				01/99 →		195			DX391▲	GX410▲
Movano 2.8L DTI Diesel				07/98 → 10/01					(21-27867-21/0)	(20-27867-03/0)
S9W 702	2799	4	94.40	Direct Injection, SOHC	84/114	BX400 (Fibre), 1.30mm [71] (30-027868-00)				
8140.23.2585/ 8140.23.3700/ 8140.43.2585/ 8140.43.3700/ 8140.43.3900	2800	4	94.40	Sofim, Turbo Intercooled	84/114	BX410 (Fibre), 1.40mm [71] (30-027883-00) BX420 (Fibre), 1.50mm [71] (30-027884-00)				
Omega 1.8L				09/87 → 03/94		196			DP810	EK482
Omega 1.8L N				09/86 → 08/87					(21-25818-22/0)	(22-26131-01/0)
Omega 1.8L S				09/86 → 03/94						
18 NV	1796	4	84.80	Carburettor, SOHC	60/82	BP810 (Fibre) (30-025818-10)				
E 18 NVR	1796	4	84.80	Carburettor, SOHC	65/88					
18 SV	1796	4	84.80	Carburettor, SOHC	66/90					
Omega 1.8L				09/86 → 03/94		197			DP811	EK482
18 SEH	1796	4	84.80	MPi, SOHC	85/115	BP810 (Fibre) (30-025818-10)		(21-25818-23/0)	(22-26131-01/0)	
Omega 2.0L				09/86 → 03/94		198			DP820	EK482
20 SE	1998	4	86.00	Motronic, SOHC	85-90/ 115- 122	BP820 (Fibre) (30-025819-10)		(21-25819-21/0)	(22-26131-01/0)	

								
HBS120 Ⓢ (22-51008B) M12x1.50x118mm (x10)	JD5189	JM5086	JH5041 ● KG5012 16x23x1.5mm	HR646 Ⓢ 24-30670-60/0	NF846 25x42x7mm, FPM/ACM (50-319516-00) NA5036 Ⓢ 42x54x6mm, FPM (50-319473-00) NF850 Ⓢ 85x105x8mm, FPM (50-319183-00)	HL5017 [245]Ⓢ	 AC5070, AC5080, AC5090	 AE5210
	JD5189	JM5086	JH5041 ● KG5012 16x23x1.5mm	HR646 Ⓢ 24-30670-60/0	NF846 25x42x7mm, FPM/ACM (50-319516-00) NA5036 Ⓢ 42x54x6mm, FPM (50-319473-00) NF850 Ⓢ 85x105x8mm, FPM (50-319183-00)	HL5017 [245]Ⓢ	 AE5220	 AY290, AY300, AY310
HBS373 Ⓢ (22-51110B) M12x1.50x131mm (x10)	JD5891 ■ JD5892	HM5290 Ⓢ						 BP810
HBS011 Ⓢ (22-51004B) M12x1.25x160mm (x10) M12x1.25x119mm (x12)		JN969 (50-027678-00)						 BP820
HBS373 Ⓢ (22-51110B) M12x1.50x131mm (x10)								 BX400, BX410, BX420
HBS011 Ⓢ (22-51004B) M12x1.25x160mm (x10) M12x1.25x119mm (x12)	JC054 ■ (x4) (31-024274-10) JC055 ■ (x4) (31-025031-10)	JN956	JJ519 (31-025623-00)	HR602 Ⓢ 24-30670-61/0	NF885 Ⓢ [3] 70x159x16mm, FPM (50-307266-70) NF883 Ⓢ [3] 114x171x13mm, FPM (50-307265-70)			 JC054
HBS003 Ⓢ (22-29009B) M11x1.25x140mm (x10)	JC757 ■ (31-025817-10) JC282 Ⓢ (31-024625-20) Ⓢ JE120 (31-024767-00)	JN693 [128] (31-026198-10)	JJ385 [148] (50-026131-00)	PA565 (x8) (50-305900-50) HR342 Ⓢ (24-30590-05/0)	NC006 Ⓢ 35x48x7mm, MVQ (50-319161-00) NB700 Ⓢ 31x50x8mm, FPM (50-306551-50) NB806 Ⓢ 90x104x11mm, FPM (50-306552-00)	NB575 [2]Ⓢ		 JC055
HBS011 Ⓢ (22-51004B) M12x1.25x160mm (x10) M12x1.25x119mm (x12)								 JC282
HBS003 Ⓢ (22-29009B) M11x1.25x140mm (x10)	JC756 ■ (31-025820-20) JC282 Ⓢ (31-024625-20) Ⓢ JE120 (31-024767-00)	JN693 [128] (31-026198-10)	JJ385 (x2) [148] (50-026131-00)	PA565 (x8) (50-305900-50) HR342 Ⓢ (24-30590-05/0)	NC006 Ⓢ 35x48x7mm, MVQ (50-319161-00) NB700 Ⓢ 31x50x8mm, FPM (50-306551-50) NB806 Ⓢ 90x104x11mm, FPM (50-306552-00)	NB575 [2]Ⓢ		 JC756
HBS003 Ⓢ (22-29009B) M11x1.25x140mm (x10)	JC756 ■ (31-025820-20) JC282 Ⓢ (31-024625-20) Ⓢ JE120 (31-024767-00)	JN693 [128] (31-026198-10)	JJ385 (x2) [148] (50-026131-00)	PA565 (x8) (50-305900-50) HR342 Ⓢ (24-30590-05/0)	NC006 Ⓢ 35x48x7mm, MVQ (50-319161-00) NB700 Ⓢ 31x50x8mm, FPM (50-306551-50) NB806 Ⓢ 90x104x11mm, FPM (50-306552-00)	NB575 [2]Ⓢ		 JC757
HBS003 Ⓢ (22-29009B) M11x1.25x140mm (x10)	JC756 ■ (31-025820-20) JC282 Ⓢ (31-024625-20) Ⓢ JE120 (31-024767-00)	JN693 [128] (31-026198-10)	JJ385 (x2) [148] (50-026131-00)	PA565 (x8) (50-305900-50) HR342 Ⓢ (24-30590-05/0)	NC006 Ⓢ 35x48x7mm, MVQ (50-319161-00) NB700 Ⓢ 31x50x8mm, FPM (50-306551-50) NB806 Ⓢ 90x104x11mm, FPM (50-306552-00)	NB807 [2]Ⓢ		 JE120
								 JN693
								 JN956
								 JN969
								 JJ385
								 JJ519







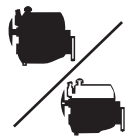



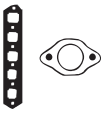

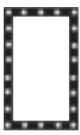

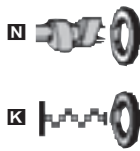

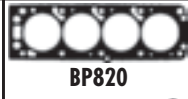

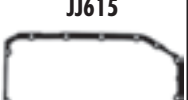
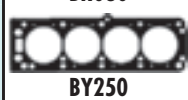



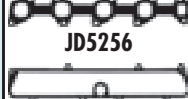

OPEL



KW/PS



Model		Year Range		Power (KW/PS)	Engine Code	Notes
Omega 2.0L		09/90 → 03/94		199	BP820 (Fibre)	DP820 (21-25819-21/0)
Omega 2.0L i		09/90 → 03/94			(30-025819-10)	EK482 (22-26131-01/0)
C 20 NEJ	1998	4	86.00	MPI, SOHC	73-74/ 99-100	
C 20 NEF	1998	4	86.00	MPI, SOHC	74/100	
Omega 2.0L		03/94 → 12/00		200	BP820 (Fibre)	DP820 (21-25819-21/0)
20 SE	1998	4	86.00	Motronic, SOHC	85-90/ 115- 122	EK482 (22-26131-01/0)
Omega 2.0L		03/94 → 09/99		201	BP820 (Fibre)	EC130 (22-28793-00/0)
X 20 SE	1998	4	86.00	Injection, SOHC	85/115	
Omega 2.0L 16V		03/94 → 09/99		202	BY250 (Fibre)	DY250 (21-27987-20/0)
X 20 XEV	1998	4	86.00	Injection, DOHC	100/136	EC130 (22-28793-00/0) HC5007 [212] (22-28386-00/0)
Omega 2.0L DTI 16V Diesel		09/97 → 09/00		203	AB5671 (MLS), 1.30mm, 1 Notch AB5681 (MLS), 1.40mm, 2 Notches	CB5670▲■ (21-29011-20/0) EB5670 (22-29011-00/0)
X 20 DTH	1995	4	84.00	Direct Injection	74/100	
Omega 2.0L i		09/86 → 03/94		204	BP820 (Fibre)	DP820 (21-25819-21/0)
C 20 NE	1998	4	86.00	MPI, SOHC	85/115	EK482 (22-26131-01/0)
Omega 2.2L 16V		09/99 → 07/03		205	BY250 (Fibre)	DY253 (21-27987-22/0)
Y 22 XE/Z 22 XE	2198	4	86.00	Injection, DOHC	106/144	EC101 (22-27206-02/0)
Omega 2.2L DTI 16V Diesel		09/00 → 07/03		206	AB5671 (MLS), 1.30mm, 1 Notch AB5681 (MLS), 1.40mm, 2 Notches	CB5670▲■ (21-29011-20/0) EB5670 (22-29011-00/0)
Y 22 DTH	2172	4	84.00	Direct Injection	85/88/ 92/115/ 120/ 125	
Omega 2.3L D Diesel		09/86 → 03/94		207	BR010 (Fibre), 1.30mm, 1 Hole BR020 (Fibre), 1.40mm, 2 Holes BR030 (Fibre), 1.50mm, 3 Holes	DR010▲ (21-23007-23/0) EJ161
23 YD	2260	4	92.00	SOHC	54/73	

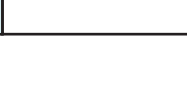





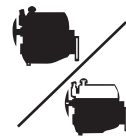



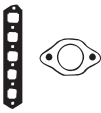

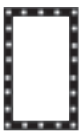

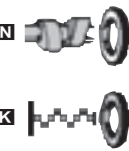

















































































































































								
HBS003 ⊕ (22-29009B) M11x1.25x140mm (x10)	JC756 ■ (31-025820-20) JC282 ■ (31-024625-20)	JN693 [128] (31-026198-10)	JJ385 [148] (50-026131-00)	PA565 (x8) (50-305900-50) HR342 ■ (24-30590-05/0)	NC006 ■ 35x48x7mm, MVQ (50-319161-00) NB700 ■ 31x50x8mm, FPM (50-306551-50) NB806 ■ 90x104x11mm, FPM (50-306552-00)	NB575 [2]■ NB807 [2]■		 BP820  JJ615  BR010, BR020, BR030  JJ616  BY250  JC282  JJ617  JC756  JD451  JD5255  JD5256  JD5347  JE120  JM5159  JN521  JN523  JN693  JP016  JP083  HC417  JH5057  JJ385
HBS003 ⊕ (22-29009B) M11x1.25x140mm (x10) →12/96 HBS053 ⊕ (22-29099B) M11x1.25x140mm (x10) 01/97→	JC756 ■ (31-025820-20) JC282 ■ (31-024625-20) JE120 ⊕ (31-024767-00)	JN693 [128] (31-026198-10)	JJ385 (x2) [148] (50-026131-00)	PA565 (x8) (50-305900-50) HR342 ■ (24-30590-05/0)	NC006 ■ 35x48x7mm, MVQ (50-319161-00) NB700 ■ 31x50x8mm, FPM (50-306551-50) NB806 ■ 90x104x11mm, FPM (50-306552-00)	NB807 [2]■		
HBS003 ⊕ (22-29009B) M11x1.25x140mm (x10)	JC282 ■ (31-024625-20) JE120 ⊕ (31-024767-00)	JP083	JJ615 (31-028793-00)	PA565 (x8) (50-305900-50) HR342 ■ (24-30590-05/0)	NC006 ■ 35x48x7mm, MVQ (50-319161-00) NB700 ■ 31x50x8mm, FPM (50-306551-50) NB806 ■ 90x104x11mm, FPM (50-306552-00)	NB575 [2]■ NB807 [2]■		
HBS054 ⊕ (22-29013B) M11x1.25x105mm (x10)	JD451 ■ (31-027699-00) JD450 ■ (31-027684-00) JE120 ⊕ (31-024767-00)	JP016 (50-027683-00)	JJ615 (31-028793-00) JJ616 ■ [212] (31-028386-00) JJ617 ■ [212] (31-028385-00)	HR791 ■ 24-30614-76/0	NC006 ■ (x2) 35x48x7mm, MVQ (50-319161-00) NB700 ■ 31x50x8mm, FPM (50-306551-50) NB806 ■ 90x104x11mm, FPM (50-306552-00)			
HBS298 ⊕ (22-29016B) M12x1.50x235mm (x10)	JD5255 ■ (31-029721-00) JD5347 ■ ■ (31-029942-00) JD5256 ■ (31-029722-00)	JM5159 (50-029633-00)	JH5057 (31-029575-00)	HR791 ■ 24-30614-76/0	NA5069 ■ 55x68x8mm, FPM (50-319515-00) NA5209 ■ 99x114x11mm, FPM (50-319514-00)			
HBS003 ⊕ (22-29009B) M11x1.25x140mm (x10)	JC756 ■ (31-025820-20) JC282 ■ (31-024625-20) JE120 ⊕ (31-024767-00)	JN693 [128] (31-026198-10)	JJ385 [148] (50-026131-00)	PA565 (x8) (50-305900-50) HR342 ■ (24-30590-05/0)	NC006 ■ 35x48x7mm, MVQ (50-319161-00) NB700 ■ 31x50x8mm, FPM (50-306551-50) NB806 ■ 90x104x11mm, FPM (50-306552-00)	NB575 [2]■ NB807 [2]■		
HBS054 ⊕ (22-29013B) M11x1.25x105mm (x10)	JD450 ■ (31-027684-00) JD5300 ■ (31-027684-10) (MLS)	JP016 (50-027683-00)	JH5119 (31-030116-00)	HR791 ■ 24-30614-76/0	NC006 ■ (x2) 35x48x7mm, MVQ (50-319161-00) NB700 ■ 31x50x8mm, FPM (50-306551-50) NB806 ■ 90x104x11mm, FPM (50-306552-00)			
HBS298 ⊕ (22-29016B) M12x1.50x235mm (x10)	JD5255 ■ (31-029721-00) JD5347 ■ ■ (31-029942-00) JD5256 ■ (31-029722-00)	JM5159 (50-029633-00)	JH5057 (31-029575-00)	HR791 ■ 24-30614-76/0	NA5069 ■ 55x68x8mm, FPM (50-319515-00) NA5209 ■ 99x114x11mm, FPM (50-319514-00)			
HBS160 ⊕ (22-29004B) M13x1.50x134mm (x10)		JN523 ■ JN521 ■ (31-023007-10)	HC417 ■ (23-21237-01/0)	PA543 (x8) (50-305908-10) HR794 ■ (24-30590-81/0)	NB628 ■ 45x60x9mm, ACM (50-305272-00) NB690 ■ 81x100.1x11.5mm, FPM (50-319087-00)			



KW/PS



Model		Year Range	Power (KW/PS)	Engine Details	Accessories	Other
Omega 2.3L TD Diesel		09/86 → 08/88	208		BR010 (Fibre), 1.30mm, 1 Hole (30-025657-10)	DR010▲ (21-23007-23/0)
Omega 2.3L TD Interc. Diesel		08/88 → 03/94			BR020 (Fibre), 1.40mm, 2 Holes (30-025658-10)	DR013▲■
23 YDT	2260	4	92.00	SOHC	66/89	
23 DTR	2260	4	92.00	SOHC	74/100	
Omega 2.4L i		09/88 → 03/94	209		BJ170 (Fibre) (30-025662-10)	
C 24 NE	2410	4	95.00	MPi	92/125	
Omega 2.5L DTI Diesel		09/01 → 07/03	210		AC5320 (MLS), 1.45mm, 1 Hole 30-028800-00	DZ660▲■ 21-29149-20/0
Y 25 DT	2497	6	80.00	Direct Injection, DOHC	110/150	
					AC5330 (MLS), 1.55mm, 2 Holes 30-028801-00	
					AC5340 (MLS), 1.65mm, 3 Holes 30-028802-00	
					AB5980 (MLS), 1.80mm 30-029183-00	
Omega 2.5L TD Diesel		04/94 → 07/03	211		BZ110 (Fibre), 1.68mm, 2 Holes 30-027395-20	DW731▲■ 21-27179-22/0
X 25 TD	2498	6	80.00	SOHC	96/130	EY280 22-27096-02/0
25 DT	2498	6	80.00	SOHC	96/131	
X 25 TD	2498	6	80.00	Indirect Injection, SOHC	96/131	
					BZ120 (Fibre), 1.87mm, 3 Holes 30-027396-20	
Omega 2.5L V6		03/94 → 09/00	212		BY270 (Fibre) (x2) (30-027690-00)	DY271 (21-27690-21/0)
X 25 XE	2498	6	81.60	Injection, DOHC, V6	125/170	EY300
Omega 2.6L i		09/90 → 03/94	213		BT530 (Fibre) (30-026239-10)	
C 26 NE	2594	6	88.80	MPi	110/150	
Omega 2.6L V6		09/00 → 07/03	214			
Y 26 SE	2597	6	83.20	Injection, DOHC, V6	125- 132/ 170- 180	
Omega 3.0L 24V		09/89 → 03/94	215		BV950 (Fibre) (30-027397-00)	DV951
Omega 3.0L 24V (3000)		09/89 → 03/94				EB950 (22-27392-00/0)
C 30 SEJ	2969	6	95.00	MPi, DOHC	147/200	
C 30 SE	2969	6	95.00	MPi, DOHC	150/204	
Omega 3.0L V6		04/94 → 02/01	216		BY300 (Fibre) (30-027849-00)	DY300 (21-27849-20/0)
X 30 XE	2962	6	86.00	MPi, DOHC, V6	155/211	
Omega 3.2L V6		02/01 → 07/03	217			
Y 32 SE	3175	6	87.50	Injection, DOHC, V6	160/218	











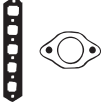

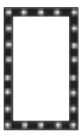

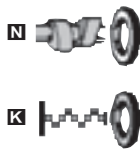

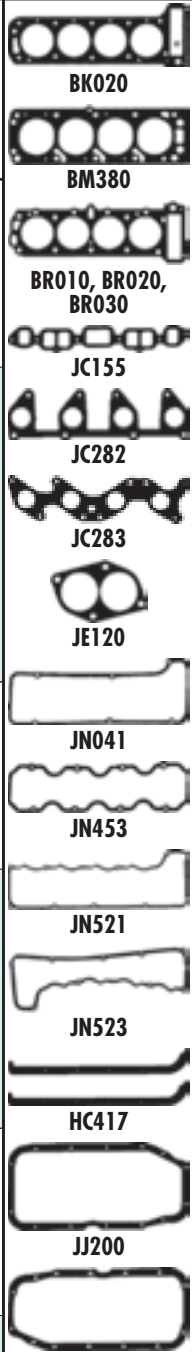



































































								
HBS163 Ⓢ (22-29010B) M13x1.50x134mm (x10)	JD5765 (31-025415-10)	JN523 Ⓢ JN521 Ⓢ (31-023007-10)	HC417 Ⓢ (23-21237-01/0)	PA543 (x8) (50-305908-10) HR794 Ⓢ (24-30590-81/0)	NB628 Ⓢ 45x60x9mm, ACM (50-305272-00) NB690 Ⓢ 81x100.1x11.5mm, FPM (50-319087-00)			 AB5980  AC5320, AC5330  AC5340  BR010, BR020, BR030  BT530  BV950  BY270  BY300  BZ110, BZ120  JD187  JD274  JD276  JD459  JD5107  JD5108  JD5134  JD5183  JD5202
HBS161 Ⓢ (22-29007B) M12x1.50x64mm (x5) M12x1.50x97.5mm (x5)	JD187 (31-026476-10)	JN923 (50-026499-00) JN924 (x2)	JH5019 Ⓢ (50-026493-00)	HR336 Ⓢ (x2) (24-30656-05/0)	NB628 Ⓢ 45x60x9mm, ACM (50-305272-00) NB469 Ⓢ 77x100x11.5mm, FPM (50-306260-50)			 JM5094  JM5095  JM5106  JM521  JM523  JM694  JN923  JN924  JN955  HC295  HC417  JH5019  JJ536  JJ572  JJ573
HBS066 Ⓢ (22-11005B) M12x1.50x146.5mm (x14)	JD5108 Ⓢ (x6) (50-029152-00) JD5107 ⓈⓈ (x6) (50-029153-00) JD5183 Ⓢ (x3) (31-029124-00)	JM5106 50-029149-00		PA5016 (x24) 50-307240-70				 JM5106  JM521  JM523  JM694  JN923  JN924  JN955  HC295  HC417  JH5019  JJ536  JJ572  JJ573
HBS066 Ⓢ (22-11005B) M12x1.50x146.5mm (x14)	JD274 Ⓢ (x6) 31-027183-00 JD276 Ⓢ [274] 31-027181-00 JD5134 Ⓢ (x4) (31-029321-00)	JN955 50-027179-00	JJ536 (31-027096-20)	HR280 Ⓢ 24-30614-75/0	NF637 Ⓢ 48x65x10mm, FPM (50-306222-50) NB431 Ⓢ 90x110x12mm, FPM (50-306091-50)			 JM5106  JM521  JM523  JM694  JN923  JN924  JN955  HC295  HC417  JH5019  JJ536  JJ572  JJ573
HBS164 Ⓢ (22-29011B) M11x1.25x105mm (x16)	JD5202 Ⓢ (x2) (50-027980-00) JD5203 ⓈⓈ (x3) (50-027979-00) JD459 Ⓢ (x2) (31-027698-00)	JM5095 Ⓢ (50-027697-00) JM5094 Ⓢ (50-027696-00) HM5294 Ⓢ (24-27696-00/0)	JJ573 Ⓢ (50-027851-00) JJ572 Ⓢ (50-027852-00)	HR5062 Ⓢ 24-30614-73/0	NC006 (x4) 35x48x7mm, MVQ (50-319161-00) NB884 Ⓢ 38x50x5.5mm, FPM (50-319010-00) NB806 Ⓢ 90x104x11mm, FPM (50-306552-00)			 JM5095  JM5094  HM5294  JJ573  JJ572  HR5062  NC006  NB884  NB806  JD5202  JD5203  JD459  JD5107  JD5108  JD5134  JD5183  JD5202
		JN694 (50-026098-00)	HC295 Ⓢ (23-21243-01/0) HC5008 Ⓢ	HR336 Ⓢ (x3) (24-30656-05/0)	NB628 Ⓢ 45x60x9mm, ACM (50-305272-00) NB469 Ⓢ 77x100x11.5mm, FPM (50-306260-50)			 JM694  JN923  JN924  JN955  HC295  HC417  JH5019  JJ536  JJ572  JJ573
HBS164 Ⓢ (22-29011B) M11x1.25x105mm (x16)	JD5202 Ⓢ (x2) (50-027980-00) JD5203 ⓈⓈ (x3) (50-027979-00)	JD5204 (x2) (50-028690-00)		HR5062 Ⓢ 24-30614-73/0	NC006 (x4) 35x48x7mm, MVQ (50-319161-00) NB884 Ⓢ 38x50x5.5mm, FPM (50-319010-00) NB806 Ⓢ 90x104x11mm, FPM (50-306552-00)			 JM5095  JM5094  HM5294  JJ573  JJ572  HR5062  NC006  NB884  NB806  JD5202  JD5203  JD459  JD5107  JD5108  JD5134  JD5183  JD5202
HBS417 (22-29026B) M12x1.50x88mm (x14)			JJ508 (50-027392-00)	PA565 (x24) (50-305900-50) HR342 Ⓢ (x3) (24-30590-05/0)				 JM5095  JM5094  HM5294  JJ573  JJ572  HR5062  NC006  NB884  NB806  JD5202  JD5203  JD459  JD5107  JD5108  JD5134  JD5183  JD5202
HBS164 Ⓢ (22-29011B) M11x1.25x105mm (x16)	JD5202 Ⓢ (50-027980-00) JD5203 ⓈⓈ (x3) (50-027979-00) JD459 Ⓢ (x2) (31-027698-00)	JM5095 Ⓢ (50-027697-00) JM5094 Ⓢ (50-027696-00) HM5294 Ⓢ (24-27696-00/0)	JJ573 Ⓢ (50-027851-00) JJ572 Ⓢ (50-027852-00)	HR5062 Ⓢ 24-30614-73/0	NC006 (x4) 35x48x7mm, MVQ (50-319161-00) NB884 Ⓢ 38x50x5.5mm, FPM (50-319010-00) NB806 Ⓢ 90x104x11mm, FPM (50-306552-00)			 JM5095  JM5094  HM5294  JJ573  JJ572  HR5062  NC006  NB884  NB806  JD5202  JD5203  JD459  JD5107  JD5108  JD5134  JD5183  JD5202
HBS164 Ⓢ (22-29011B) M11x1.25x105mm (x16)								 JM5095  JM5094  HM5294  JJ573  JJ572  HR5062  NC006  NB884  NB806  JD5202  JD5203  JD459  JD5107  JD5108  JD5134  JD5183  JD5202



KW/PS



Rekord 1.7L						09/77 → 10/82	218	BK020 (Fibre)	DK020	
17 N	1698	4	88.00	Carburettor, SOHC	44-49/ 60-67		(30-023070-20)	(21-23070-27/0)		
Rekord 1.8L						11/82 → 08/86	219	BM380 (Fibre)	DM380	EK482
Rekord 1.8L S						11/82 → 08/86		(30-024765-10)		(22-26131-01/0)
18 N	1796	4	84.80	Carburettor, SOHC	55/75				01/86 →	
18 S	1796	4	84.80	Carburettor, SOHC	65-66/ 88-90				Eng.14159466 →	
Rekord 1.8L E						05/85 → 08/86	220	BM380 (Fibre)	DM381	
C 18 NV	1796	4	84.80	Carburettor, SOHC	74/100		(30-024765-10)	(21-24765-23/0)		
Rekord 2.0L						09/75 → 10/82	221	BJ170 (Fibre)		
Rekord 2.0L E						09/77 → 10/84		(30-025662-10)		
Rekord 2.0L S						09/75 → 08/86				
Rekord Coupe 2.0L						09/75 → 08/77				
20 N	1979	4	95.00	Injection, CIH	56-66/ 76-90					
20 S	1979	4	95.00	Carburettor, CIH	74/100					
20 E	1979	4	95.00	MPi, CIH	81/110					
Rekord 2.2L D Diesel						08/78 → 08/86	222	BRO10 (Fibre), 1.30mm, 1 Hole	DR012▲■	EJ161
23 D	2260	4	92.00	Indirect Injection, SOHC	48/65		(30-025657-10)	(21-24240-23/0)		
							BRO20 (Fibre), 1.40mm, 2 Holes			
							(30-025658-10)			
							BRO30 (Fibre), 1.50mm, 3 Holes			
							(30-025659-10)			
Rekord 2.2L E						11/84 → 08/86	223	BJ170 (Fibre)	DJ172	
22 E	2197	4	95.00	Injection, CIH	85/115		(30-025662-10)	(21-25662-27/0)		
Rekord 2.3L D Diesel						11/82 → 08/86	224	BRO10 (Fibre), 1.30mm, 1 Hole	DR012▲■	EJ161
23 D	2260	4	92.00	Indirect Injection, SOHC	48/65		(30-025657-10)	(21-24240-23/0)		
							BRO20 (Fibre), 1.40mm, 2 Holes			
							(30-025658-10)			
							BRO30 (Fibre), 1.50mm, 3 Holes			
							(30-025659-10)			
Rekord 2.3L TD Diesel						06/84 → 08/86	225	BRO10 (Fibre), 1.30mm, 1 Hole	DR010▲	EJ161
23 TD	2260	4	92.00		63/74/ 86/101		(30-025657-10)	(21-23007-23/0)		
							BRO20 (Fibre), 1.40mm, 2 Holes			
							(30-025658-10)			
							BRO30 (Fibre), 1.50mm, 3 Holes			
							(30-025659-10)			
Senator 2.2L E						11/84 → 08/87	226	BJ170 (Fibre)		
22 E	2197	4	95.00	Injection, CIH	85/115		(30-025662-10)			











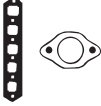

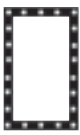

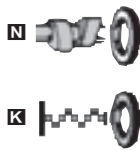

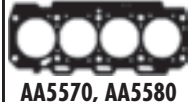







														
		JC155 (31-021058-20)	JN041 (31-022926-10)	HC417  (23-21237-01/0)	HR336  (24-30656-05/0)	 NC006 35x48x7mm, MVQ (50-319161-00)  NB628 45x60x9mm, ACM (50-305272-00)  NB469 77x100x11.5mm, FPM (50-306260-50)	NB575 [2] 	BK020 BM380 BR010, BR020, BR030 JC155 JC282 JC283 JE120						
HBS003  (22-29009B) M11x1.25x140mm (x10)	JC283  (31-025183-10) JC282  (31-024625-20)  JE120 (31-024767-00)	JN453 [127] (31-024572-00)	JJ200 (31-025011-00) →12/85 JJ385 [148] (50-026131-00) 01/86 →	HR343  (24-30602-50/0)	 NC006 35x48x7mm, MVQ (50-319161-00)  NB700 31x50x8mm, FPM (50-306551-50)  NB701 86x104x11mm, FPM (50-306261-50) →12/85  NB806 90x104x11mm, FPM (50-306552-00) 01/86 →	NB575 [2] 	HBS003  (22-29009B) M11x1.25x140mm (x10)	JC283  (31-025183-10) JC282  (31-024625-20)  JE120 (31-024767-00)	JN453 [127] (31-024572-00)	JJ200 (31-025011-00)	HR343  (24-30602-50/0)	 NC006 35x48x7mm, MVQ (50-319161-00)  NB700 31x50x8mm, FPM (50-306551-50)  NB701 86x104x11mm, FPM (50-306261-50)	NB575 [2] 	JN041 JN453 JN521 JN523 HC417 JJ200 JJ385
HBS161  (22-29007B) M12x1.50x64mm (x5) M12x1.50x97.5mm (x5)	JC155 (31-021058-20)	JN041 (31-022926-10)	HC417  (23-21237-01/0)	HR336  (24-30656-05/0)	 NB628 45x60x9mm, ACM (50-305272-00)  NB469 77x100x11.5mm, FPM (50-306260-50)	NB575 [2] 	HBS161  (22-29007B) M12x1.50x64mm (x5) M12x1.50x97.5mm (x5)	JC155 (31-021058-20)	JN041 (31-022926-10)	HC417  (23-21237-01/0)	HR336  (24-30656-05/0)	 NB628 45x60x9mm, ACM (50-305272-00)  NB690 81x100.1x11.5mm, FPM (50-319087-00)	NB575 [2] 	JN521 JN523 HC417 JJ200 JJ385
HBS160  (22-29004B) M13x1.50x134mm (x10)		JN523  JN521  (31-023007-10)	HC417  (23-21237-01/0)	PA543 (x8) (50-305908-10) HR794  (24-30590-81/0)	 NB628 45x60x9mm, ACM (50-305272-00)  NB690 81x100.1x11.5mm, FPM (50-319087-00)	NB575 [2] 	HBS160  (22-29004B) M13x1.50x134mm (x10)		JN523  JN521  (31-023007-10)	HC417  (23-21237-01/0)	PA543 (x8) (50-305908-10) HR794  (24-30590-81/0)	 NB628 45x60x9mm, ACM (50-305272-00)  NB690 81x100.1x11.5mm, FPM (50-319087-00)	NB575 [2] 	JN521 JN523 HC417 JJ200 JJ385
HBS163  (22-29010B) M13x1.50x134mm (x10)	JD5765 (31-025415-10)	JN521 (31-023007-10)	HC417  (23-21237-01/0)	PA543 (x8) (50-305908-10) HR794  (24-30590-81/0)	 NB628 45x60x9mm, ACM (50-305272-00)  NB690 81x100.1x11.5mm, FPM (50-319087-00)	NB575 [2] 	HBS163  (22-29010B) M13x1.50x134mm (x10)	JD5765 (31-025415-10)	JN521 (31-023007-10)	HC417  (23-21237-01/0)	PA543 (x8) (50-305908-10) HR794  (24-30590-81/0)	 NB628 45x60x9mm, ACM (50-305272-00)  NB690 81x100.1x11.5mm, FPM (50-319087-00)	NB575 [2] 	JN521 JN523 HC417 JJ200 JJ385
HBS161  (22-29007B) M12x1.50x64mm (x5) M12x1.50x97.5mm (x5)		JN041 (31-022926-10)	HC417  (23-21237-01/0)	HR336  (24-30656-05/0)	 NB628 45x60x9mm, ACM (50-305272-00)  NB469 77x100x11.5mm, FPM (50-306260-50)	NB575 [2] 	HBS161  (22-29007B) M12x1.50x64mm (x5) M12x1.50x97.5mm (x5)		JN041 (31-022926-10)	HC417  (23-21237-01/0)	HR336  (24-30656-05/0)	 NB628 45x60x9mm, ACM (50-305272-00)  NB469 77x100x11.5mm, FPM (50-306260-50)	NB575 [2] 	JN521 JN523 HC417 JJ200 JJ385

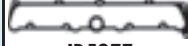

KW/PS

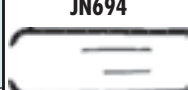

Senator 2.3L TD Diesel				11/84 → 08/87	227	BR010 (Fibre), 1.30mm, 1 Hole (30-025657-10) BR020 (Fibre), 1.40mm, 2 Holes (30-025658-10) BR030 (Fibre), 1.50mm, 3 Holes (30-025659-10)	DR010▲ (21-23007-23/0) DR013▲■	
23 TD	2260	4	92.00		63/74/ 86/101			
Senator 2.5L E				09/84 → 08/87	228	BT530 (Fibre) (30-026239-10)		EW870 (22-21235-00/0)
25 E	2490	6	87.00	L-Jetronic, CIH	96-103/ 130- 140			
Senator 2.5L i				09/90 → 09/93	229	BT530 (Fibre) (30-026239-10)		
25 NE	2490	6	87.00	Injection, SOHC	103/140			
Senator 2.6L i				09/90 → 09/93	230	BT530 (Fibre) (30-026239-10)		
C 26 NE	2594	6	88.80	MPi	110/150			
Senator 3.0L 24V				09/89 → 09/93	231	BV950 (Fibre) (30-027397-00)	DV951	EB950 (22-217392-00/0)
C 30 SE	2969	6	95.00	MPi, DOHC	150/204			
Signum 1.8L				05/03 →	232	AC5460 (MLS) (30-028674-00)	CC5460	(21-28674-20/0)
Z 18 XE	1796	4	80.50	MPi, DOHC	92/125			
Signum 1.9L CDTI Diesel				04/04 →	233	AA5570 (MLS), 0.92mm, 1 Hole (30-029094-10) AA5580 (MLS), 1.02mm, 2 Holes (30-029095-10)	CG7390▲	(21-30144-00/0) EE5181 (22-29832-01/0)
Z 19 DT	1910	4	82.00	Direct Injection	74-88/ 100- 120			
Signum 1.9L CDTI Diesel				04/04 →	234	AD5840 (MLS), 0.82mm, 0 Holes (30-029766-00) AD5850 (MLS), 0.92mm, 1 Hole (30-029767-00) AD5860 (MLS), 1.02mm, 2 Holes (30-029768-00)	CD5840▲	(21-29766-20/0) EE5181 (22-29832-01/0)
Z 19 DTH	1910	4	82.00	Direct Injection	88-110/ 120- 150			
Signum 2.0L DTI Diesel				05/03 →	235	AB5671 (MLS), 1.30mm, 1 Notch AB5681 (MLS), 1.40mm, 2 Notches	CB5671▲■	(21-29011-21/0) EB5670 (22-29011-00/0)
Y 20 DTH	1995	4	84.00	Direct Injection	74/100			
Signum 2.0L Turbo				05/03 →	236			
Z 20 NET	1998	4	86.00	Injection	129/175			
Signum 2.2L direct				05/03 →	237	AG9590 (MLS) (30-030345-00)	CG9590	(21-30345-00/0)
Z 22 YH	2198	4	86.00	Injection, DOHC	110- 114/ 150- 155			

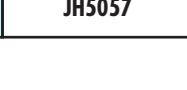









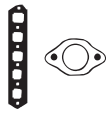

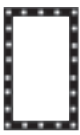

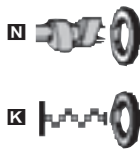







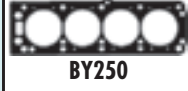







								 AA5570, AA5580  AC5460  BR010, BR020, BR030  BT530  BV950  JD468  JD5196  JD5197  JD5255  JD5256  JD5277  JD5376  JM5092  JM5159  JM5204  JM956  JN521  JN694  HC295  HC417  JH5057
HBS163 Ⓞ (22-29010B) M13x1.50x134mm (x10)	JD5765 (31-025415-10)	JN521 (31-023007-10)	HC417 Ⓞ (23-21237-01/0)	PA543 (x8) (50-305908-10) HR794 Ⓞ (24-30590-81/0)	NB628 Ⓞ 45x60x9mm, ACM (50-305272-00) NB690 Ⓞ 81x100.1x11.5mm, FPM (50-319087-00)			
		JM956 (31-022399-10) →Eng.25E45754 JN694 (50-026098-00) Eng.25E45755→	HC295 Ⓞ (23-21243-01/0)	HR336 Ⓞ (x3) (24-30656-05/0)	NB628 Ⓞ 45x60x9mm, ACM (50-305272-00) NB469 Ⓞ 77x100x11.5mm, FPM (50-306260-50)			
		JM956 (31-022399-10) →Eng.25E45754 JN694 (50-026098-00) Eng.25E45755→	HC295 Ⓞ (23-21243-01/0)	HR336 Ⓞ (x3) (24-30656-05/0)	NB628 Ⓞ 45x60x9mm, ACM (50-305272-00) NB469 Ⓞ 77x100x11.5mm, FPM (50-306260-50)			
		JN694 (50-026098-00)	HC295 Ⓞ (23-21243-01/0) HC5008 Ⓞ	HR336 Ⓞ (x3) (24-30656-05/0)	NB628 Ⓞ 45x60x9mm, ACM (50-305272-00) NB469 Ⓞ 77x100x11.5mm, FPM (50-306260-50)			
HBS417 (22-29026B) M12x1.50x88mm (x14)			JJ508 (50-027392-00)	PA565 (x24) (50-305900-50) HR342 Ⓞ (x3) (24-30590-05/0)				
HBS055 Ⓞ (22-29012B) M10x1.50x153mm (x10)	JD5196 Ⓞ (31-029039-00) JD5197 Ⓞ (31-029040-00)	JM5092 (50-029087-00)		PA5025 (x16) (50-319386-00) HR5048 Ⓞ (24-31938-60/0)	NC006 Ⓞ (x2) 35x48x7mm, MVQ (50-319161-00) NC065 Ⓞ 30x40x7mm, FPM (50-306142-00) NB698 Ⓞ 80x98x10mm, FPM (50-319273-00)			
HBS227 Ⓞ (22-17018B) M12x1.25x218mm (x10)	JD468 Ⓞ (31-028377-00) (MLS)	JM5204 (50-029935-00)		HR363 Ⓞ	NA5053 30x42x7mm, FPM (50-319488-00) NA5070 Ⓞ 31x41x7mm, FPM (50-319524-00)	HL5031 [245]Ⓞ		
HBS370 Ⓞ (22-17026B) M12x1.25x225mm (x10)	JD5376 Ⓞ (31-029969-00)	JM5204 (50-029935-00) JM7055 (Steel Elastomer)		HR5095 Ⓞ	NA5053 30x42x7mm, FPM (50-319488-00) NA5070 Ⓞ 31x41x7mm, FPM (50-319524-00)	HL5031 [245]Ⓞ		
HBS298 Ⓞ (22-29016B) M12x1.50x235mm (x10)	JD5255 Ⓞ (31-029721-00) JD5277 Ⓞ (31-029723-00) JD5256 Ⓞ (31-029722-00)	JM5159 (50-029633-00)	JH5057 (31-029575-00)	HR791 Ⓞ 24-30614-76/0	NA5069 Ⓞ 55x68x8mm, FPM (50-319515-00) NA5209 Ⓞ 99x114x11mm, FPM (50-319514-00)			
HBS416 Ⓞ (22-29025B) M11x1.50x163mm (x10)								
HBS416 Ⓞ (22-29025B) M11x1.50x163mm (x10)	JD5869 Ⓞ (31-030358-00) JD5870 Ⓞ (31-030359-00) JD5868 Ⓞ (31-030346-00)							

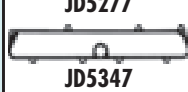

KW/PS



Signum 2.2L DTI Diesel		05/03 →		238		AB5671 (MLS), 1.30mm, 1 Notch AB5681 (MLS), 1.40mm, 2 Notches		CB5671▲■ (21-29011-21/0)		EB5670 (22-29011-00/0)	
Y 22 DTR	2172	4	84.00	Direct Injection, SOHC	92/125						
Signum 3.0L V6 CDTI Diesel		05/03 →		239		AG9770 (MLS), 0.60mm, 1 Hole ☒ AG9780 (MLS), 0.65mm, 2 Holes ☒ AG9790 (MLS), 0.70mm, 3 Holes ☒ AG9800 (MLS), 0.60mm, 1 Hole ☒ AG9810 (MLS), 0.65mm, 2 Holes ☒ AG9820 (MLS), 0.70mm, 3 Holes ☒		CG9770▲		EG9770 FG9770▲	
Y 30 DT	2958	6	87.50	Direct Injection, V6	130/177						
Z 30 DT	2958	6	87.50	Direct Injection, V6	135/184						
Signum 3.2L V6		05/03 →		240							
Z 32 SE	3175	6	88.50	Injection, DOHC, V6	155/211						
Sintra 2.2L DTI Diesel		07/97 →04/99		241		AB5671 (MLS), 1.30mm, 1 Notch AB5681 (MLS), 1.40mm, 2 Notches		CB5670▲■ (21-29011-20/0)		EB5670 (22-29011-00/0)	
X 22 DTH	2172	4	84.00	Direct Injection	85/115						
Sintra 2.2L i 16V		11/96 →04/99		242		BY250 (Fibre) (30-027987-10)		DY251 (21-27987-21/0)		EC100 (22-27206-01/0)	
X 22 XE	2198	4	86.00	Injection, DOHC	100/136						
Sintra 3.0L i 24V		11/96 →04/99		243		BY300 (Fibre) (30-027849-00)		DY300 (21-27849-20/0)			
X 30 XE	2962	6	86.00	MPI, DOHC, V6	155/211						
Speedster Convertible 2.0L Turbo		04/03 →		244		AG9570 (MLS) (30-030342-00)		CG9570 (21-30342-00/0)		EG9570	
Z 20 LET	1998	4	86.00	Injection, DOHC	140- 147/ 190- 200						
Speedster 2.2L		09/00 →		245		AG9580 (MLS) (30-030344-00)		CG9580 (21-30344-00/0)			
Z 22 SE	2198	4	86.00	Injection, DOHC	108/147						
Tigra 1.3L CDTI Diesel		06/04 →		246		AD5800 (MLS), 0.72mm (30-029762-00) AD5810 (MLS), 0.82mm, 1 Hole (30-029763-00) AD5820 (MLS), 0.92mm, 2 Holes (30-029764-00)		CD5800▲ (21-29762-20/0)			
Z 13 DT	1248	4	69.80	Direct Injection	51/70						
Tigra 1.4L		06/04 →		247		AH5030 (MLS) (30-030366-00)		CH5030 (21-30366-00/0)			
Z 14 XEP	1364	4	73.40	Injection, DOHC	66/89						







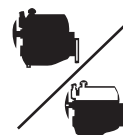



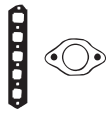

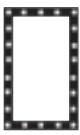

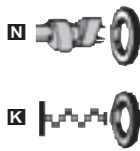









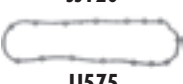



								
HBS298 Ⓢ (22-29016B) M12x1.50x235mm (x10)	JD5255 ■ (31-029721-00) JD5277 ■ ■ (31-029723-00) JD5256 ■ (31-029722-00)	JM5159 (50-029633-00)	JH5057 (31-029575-00)	HR791 ■ 24-30614-76/0	NA5069 ■ 55x68x8mm, FPM (50-319515-00) NA5209 ■ 99x114x11mm, FPM (50-319514-00)			 AD5800  JH5057  AD5810  JJ459  AD5820  JJ572  BY250  JJ573  BY300  JD451  JJ616  JD459  JD5202  JD5203  JD5255  JD5256  JD5277  JD5347  JD5412  JE5024  JM5094  JM5095  JM5159  JP016  JH5036
	JD5897 ■ (Steel Elastomer) JD5896 ■ JE5064 (Steel)	HM5292 ■		HR5094 ■				
HBS164 Ⓢ (22-29011B) M11x1.25x105mm (x16)		JM5071 (50-029232-00)	HR397 [57] 34-000410-00	HR280 ■ (x2) 24-30614-75/0	NC006 (x4) 35x48x7mm, MVQ (50-319161-00) NB884 ■ 38x50x5.5mm, FPM (50-319010-00) NB806 ■ 90x104x11mm, FPM (50-306552-00)			
HBS298 Ⓢ (22-29016B) M12x1.50x235mm (x10)	JD5255 ■ (31-029721-00) JD5347 ■ ■ (31-029942-00) JD5256 ■ (31-029722-00)	JM5159 (50-029633-00)	JH5057 (31-029575-00)	HR791 ■ 24-30614-76/0	NA5069 ■ 55x68x8mm, FPM (50-319515-00) NA5209 ■ 99x114x11mm, FPM (50-319514-00)			
HBS054 Ⓢ (22-29013B) M11x1.25x105mm (x10)	JD451 ■ (31-027699-00) JD450 ■ (31-027684-00)	JP016 (50-027683-00)	JJ459 [148] (31-027206-00)	HR791 ■ 24-30614-76/0	NC006 (x2) 35x48x7mm, MVQ (50-319161-00) NB700 ■ 31x50x8mm, FPM (50-306551-50) NB806 ■ 90x104x11mm, FPM (50-306552-00)			
HBS164 Ⓢ (22-29011B) M11x1.25x105mm (x16)	JD5202 ■ (50-027980-00) JD5203 ■ ■ (x3) (50-027979-00) JD459 ■ (x2) (31-027698-00)	JM5095 ■ (50-027697-00) JM5094 ■ (50-027696-00) HM5294 ■ (24-27696-00/0)	JJ573 ■ (50-027851-00) JJ572 ■ (50-027852-00)	HR5062 ■ 24-30614-73/0	NC006 (x4) 35x48x7mm, MVQ (50-319161-00) NB884 ■ 38x50x5.5mm, FPM (50-319010-00) NB806 ■ 90x104x11mm, FPM (50-306552-00)			
HBS054 Ⓢ (22-29013B) M11x1.25x105mm (x10)	JD451 ■ (31-027699-00) JD5903 ■ (31-030367-00) (MLS)	JP016 (50-027683-00)	JJ616 (31-028386-00) JJ617 ■ (31-028385-00)	HR791 ■ 24-30614-76/0	NC006 (x2) 35x48x7mm, MVQ (50-319161-00) NB700 ■ 31x50x8mm, FPM (50-306551-50) NB806 ■ 90x104x11mm, FPM (50-306552-00)			
HBS416 Ⓢ (22-29025B) M11x1.50x163mm (x10)	KG5337 ■ (50-350435-00) (MVQ) JD5868 ■ (31-030346-00)				NA5108 ■ 42x55x7mm, FPM (50-319392-00) NB806 ■ 90x104x11mm, FPM (50-306552-00)			
HBS353 Ⓢ (22-17025B) M10x1.25x119mm (x10)	JD5411 ■ (50-030025-00) JD5412 ■ ■ (50-030026-00) JD5413 ■ (31-030027-00) (MLS)	JM5259 (31-030023-00)	HR397 [57] 34-000410-00	HR5088 ■ (24-31952-10/0)	NA5223 ■ 40x52x7mm, FPM (50-319520-00) NA5230 ■ 78x100x9mm, PTFE (50-319522-00)	KK5646 [45]		
HBS252 Ⓢ (22-29014B) M8x1.25x119mm (x12)	JD5904 ■ (x4) (50-030368-00) (FPM) JE5024 ■ (31-029170-00)	JM5071 (50-029232-00)	JH5036 (31-029169-00)	HR5048 ■ (24-31938-60/0)	NA5108 ■ 42x55x7mm, FPM (50-319392-00) NB698 ■ 80x98x10mm, FPM (50-319273-00)	JR5030 [11]		



KW/PS

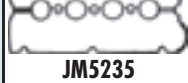
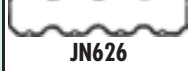

Tigra Coupe 1.4L 16V		07/94 → 12/00		248	AY210 (Fibre) (30-027985-00)	CY210 (21-27985-21/0)	EY230 (22-27665-01/0)
X 14 XE	1389	4	77.60	Injection, DOHC	66/89		
Tigra Coupe 1.6L 16V		08/97 → 08/98		249	AY220 (Fibre)	DY231 (21-27986-23/0)	EY230 (22-27665-01/0)
C 16 SEL	1598	4	79.00	Injection, SOHC	78/106		
Tigra Coupe 1.6L 16V		07/94 → 08/98		250	AY220 (Fibre)	CY220 (21-27986-21/0)	EY230 (22-27665-01/0)
X 16 XE	1598	4	79.00	Injection, DOHC	78/106		
Tigra 1.8L		06/04 →		251	AC5460 (MLS) (30-028674-00)	CC5460 (21-28674-20/0)	
Z 18 XE	1796	4	80.50	MPi, DOHC	92/125		
Vectra 1.4L S		04/88 → 06/92		252	BS260 (Fibre) (30-026329-10)	DS260 (21-26329-21/0)	EK470 (22-27194-05/0)
14 NV	1389	4	77.60	Carburettor, SOHC	53-55/ 72-75		
Vectra 1.6L		08/05 →		253	AB5540 (MLS) (30-029209-00)	CB5540 (21-29209-20/0)	EB5541 [8] (22-27665-03/0)
Vectra 1.6L 16V		06/04 →					
Z 16 XE	1598	4	79.00	MPi, DOHC	74/100		
Vectra 1.6L		01/06 →		254	AB5540 (MLS) (30-029209-00)	CB5540 (21-29209-20/0)	EB5541 [8] (22-27665-03/0)
Z 16 XEP	1598	4	79.00	Injection, DOHC	74-77/ 101- 105		
Vectra 1.6L		09/88 → 05/93		255	BP800 (Fibre) (30-025706-20)	DP800 (21-25706-26/0)	EK484 [129] (22-27194-01/0)
Vectra 1.6L S		09/88 → 05/93					
16 SV	1598	4	79.00	Carburettor, SOHC	60/82		
Vectra 1.6L i		09/93 → 11/95		256			
16 LZ2	1598	4	79.00	Injection, SOHC	55/75		
Vectra 1.6L i		09/93 → 11/95		257	BP800 (Fibre) (30-025706-20)	DP802 (21-25706-25/0)	EK484 [129] (22-27194-01/0)
X 16 SZ	1598	4	79.00	SPi, SOHC	52/71		







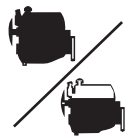

								
HBS055 Ⓢ (22-29012B) M10x1.25x153mm (x10)	JD5269 ■ (31-027984-00) JD445 ■□ (31-027881-00) JD444 ■ (31-027878-00)	JP009 ■ (50-027983-00) JP008 ■ (50-027982-00)	JJ575 [148] (50-027665-00)	HR791 ■ 24-30614-76/0	■ NC006 ■ (x2) 35x48x7mm, MVQ (50-319161-00) ■ NB697 ■ 26x42x8mm, FPM (50-306704-00) ■ NB698 ■ 80x98x10mm, FPM (50-319273-00)			 AB5540  JP008  AC5460  JP009  AY210  JH5005  AY220  JJ120  BP800  JJ575  BS260  JC281  JC824  JD444  JD445  JD448  JD5147  JD5148  JD5196  JD5197  JD5269  JE120  JM5059  JM5092  JM5235  JN626
HBS055 Ⓢ (22-29012B) M10x1.25x153mm (x10)	JD448 ■ (31-027880-00) JD445 ■□ (31-027881-00) JD444 ■ (31-027878-00)	JP009 ■ (50-027983-00) JP008 ■ (50-027982-00)	JJ575 [148] (50-027665-00)	HR791 ■ 24-30614-76/0	■ NC006 ■ (x2) 35x48x7mm, MVQ (50-319161-00) ■ NB697 ■ 26x42x8mm, FPM (50-306704-00) ■ NB698 ■ 80x98x10mm, FPM (50-319273-00)			
HBS055 Ⓢ (22-29012B) M10x1.25x153mm (x10)	JD448 ■ (31-027880-00) JD445 ■□ (31-027881-00) JD444 ■ (31-027878-00)	JP009 ■ (50-027983-00) JP008 ■ (50-027982-00)	JJ575 [148] (50-027665-00)	HR791 ■ 24-30614-76/0	■ NC006 ■ (x2) 35x48x7mm, MVQ (50-319161-00) ■ NB697 ■ 26x42x8mm, FPM (50-306704-00) ■ NB698 ■ 80x98x10mm, FPM (50-319273-00)			
HBS055 Ⓢ (22-29012B) M10x1.25x153mm (x10)	JD5196 ■ (31-029039-00) JD5197 ■ (31-029040-00)	JM5092 (50-029087-00)		PA5025 (x16) (50-319386-00) HR5048 ■ (24-319386-00/0)	■ NC006 ■ (x2) 35x48x7mm, MVQ (50-319161-00) ■ NC065 ■ 30x40x7mm, FPM (50-306142-00) ■ NB698 ■ 80x98x10mm, FPM (50-319273-00)			
HBS002 Ⓢ (22-29098B) M10x1.25x140mm (x10)	JC824 ■ (31-026334-00) JC281 ■ (31-024312-10) Ⓢ JE120 (31-024767-00)	JN626 (31-026099-10)	JH5005 [116] (31-027194-00) JJ120	PA565 (x8) (50-305900-50) HR342 ■ (24-305900-05/0)	■ NC006 ■ 35x48x7mm, MVQ (50-319161-00) ■ NB697 ■ 26x42x8mm, FPM (50-306704-00) ■ NB698 ■ 80x98x10mm, FPM (50-319273-00)	NB575 [2]■		
HBS055 Ⓢ (22-29012B) M10x1.25x153mm (x10)	JD5147 ■ (31-029203-00) JD5148 ■ (31-029204-00)	JM5059 (50-029202-00)		HR791 ■ 24-30614-76/0	■ NC006 ■ (x2) 35x48x7mm, MVQ (50-319161-00) ■ NB697 ■ 26x42x8mm, FPM (50-306704-00) ■ NB698 ■ 80x98x10mm, FPM (50-319273-00)			
HBS055 Ⓢ (22-29012B) M10x1.25x153mm (x10)	JD5147 ■ (31-029203-00) JD5148 ■ (31-029204-00)	JM5059 (50-029202-00) JM5235 (50-029985-00)		HR791 ■ 24-30614-76/0	■ NC006 ■ (x2) 35x48x7mm, MVQ (50-319161-00) ■ NB697 ■ 26x42x8mm, FPM (50-306704-00) ■ NB698 ■ 80x98x10mm, FPM (50-319273-00)			
HBS002 Ⓢ (22-29098B) M10x1.25x140mm (x10)	JC824 ■ (31-026334-00) JC281 ■ (31-024312-10) Ⓢ JE120 (31-024767-00)	JN626 (31-026099-10)	JH5005 (x2) [116] (31-027194-00) JJ120 (x2)	PA565 (x8) (50-305900-50) HR342 ■ (24-305900-05/0)	■ NC006 ■ 35x48x7mm, MVQ (50-319161-00) ■ NB697 ■ 26x42x8mm, FPM (50-306704-00) ■ NB698 ■ 80x98x10mm, FPM (50-319273-00)	NB575 [2]■		
HBS003 Ⓢ (22-29009B) M11x1.25x140mm (x10)								
HBS002 Ⓢ (22-29098B) M10x1.25x140mm (x10)	JC824 ■ (31-026334-00) JC281 ■ (31-024312-10)	JN626 (31-026099-10)	JH5005 [116] (31-027194-00) JJ120	PA565 (x8) (50-305900-50) HR342 ■ (24-305900-05/0)	■ NC006 ■ 35x48x7mm, MVQ (50-319161-00) ■ NB697 ■ 26x42x8mm, FPM (50-306704-00) ■ NB698 ■ 80x98x10mm, FPM (50-319273-00)	NB575 [2]■		

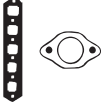

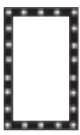
KW/PS

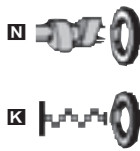

Vectra 1.6L i				10/95 → 07/03	258	BP800 (Fibre) (30-025706-20)	DP806 (21-25706-30/0)
X 16 SZR	1598	4	79.00	SPi, SOHC	55/75		
Vectra 1.6L i				09/88 → 11/95	259	BP800 (Fibre) (30-025706-20)	DP802 (21-25706-25/0)
C 16 NZ/C 16 NZ2	1598	4	79.00	SPi, SOHC	55/75		EK484 [129] (22-27194-01/0)
Vectra 1.6L i				09/88 → 10/90	260	BP800 (Fibre) (30-025706-20)	DP802 (21-25706-25/0)
E 16 NZ	1598	4	79.00	SPi, SOHC	55/75		EK484 [129] (22-27194-01/0)
Vectra 1.6L i 16V				10/95 → 07/02	261	AB5540 (MLS) (30-029209-00) Y16XE, Z16SE AY220 (Fibre) X16XEL	CB5540 (21-29209-20/0) Y16XE, Z16SE CY221 (21-27986-22/0) → 12/97 X16XEL DY232 (21-27986-25/0) 01/98 → X16XEL
Y 16 XE	1598	4	79.00	MPi	74/100		EY230 (22-27665-01/0) → Eng.02MB4997
Z 16 XE	1598	4	79.00	MPi, DOHC	74/100		→ Eng.20R22448
X 16 XEL	1598	4	79.00	Injection, DOHC	74/78/ 100/ 106		EB5541 [8] (22-27665-03/0) Eng.02MB4998 → Eng.20R22449 →
Vectra 1.7L D Diesel				09/88 → 11/95	262	BY330 (Fibre), 1.30mm (30-027492-10) BY340 (Fibre), 1.40mm, 1 Notch (30-027493-10) BY350 (Fibre), 1.50mm, 2 Notches (30-027494-10)	DL011▲ (21-26198-20/0)
17 D	1699	4	82.50	SOHC	42/57		EK485 (22-25011-04/0)
17 DR	1699	4	82.50	SOHC	42-44/ 57-60		
Vectra 1.7L TD Diesel				03/90 → 12/98	263	AB5010 (MLS), 1.40mm (30-029163-00) AB5020 (MLS), 1.45mm, 1 Hole (30-029164-00) AB5030 (MLS), 1.50mm, 2 Holes (30-029165-00)	CY811▲■ (21-27776-22/0)
17 DT (TC4EE1)/ X 17 DT (TC4EE1)	1686	4	79.00	SOHC	60/81		FY811▲ (20-27776-02/0)
Vectra 1.8L				04/02 →	264	AC5460 (MLS) (30-028674-00)	CC5460 (21-28674-20/0)
Vectra 1.8L 16V				04/02 →			
Vectra 1.8L i 16V				09/00 → 07/03			
Z 18 XEL	1796	4	80.50	Injection, DOHC	81-85/ 110- 116		
Z 18 XE	1796	4	80.50	MPi, DOHC	92/125		
Vectra 1.8L i				03/90 → 11/95	265	BP810 (Fibre) (30-025818-10)	DP810 (21-25818-22/0)
Vectra 1.8L S				09/88 → 10/90			EK482 (22-26131-01/0)
Vectra 1.8L S 4x4				01/89 → 07/89			
E 18 NVR	1796	4	84.80	Carburettor, SOHC	65/88		
18 SV	1796	4	84.80	Carburettor, SOHC	66/90		
C 18 NZ	1796	4	84.80	SPi, SOHC	66/90		







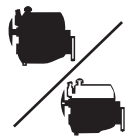



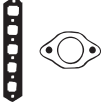

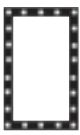

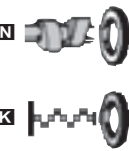









































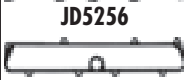





































































										
HBS002 Ⓢ (22-29098B) M10x1.25x140mm (x10)	JC824 ■ (31-026334-00) JC281 ■ (31-024312-10)	JN929 (50-027192-10)	JH5005 [116] (31-027194-00) JJ120	PA565 (x8) (50-305900-50) HR342 ■ (24-305900-05/0)	NC006 ■ 35x48x7mm, MVQ (50-319161-00) NB697 ■ 26x42x8mm, FPM (50-306704-00) NB698 ■ 80x98x10mm, FPM (50-319273-00)			AB5540 AC5460 AY220 BP800 BP810 BY330, BY340, BY350	JM5059 JM5092 JN626 JN693 JN777 JN929	
HBS002 Ⓢ (22-29098B) M10x1.25x140mm (x10)	JC824 ■ (31-026334-00) JC281 ■ (31-024312-10)	JN626 (31-026099-10)	JH5005 (x2) [116] (31-027194-00) JJ120 (x2)	PA565 (x8) (50-305900-50) HR342 ■ (24-305900-05/0)	NC006 ■ 35x48x7mm, MVQ (50-319161-00) NB697 ■ 26x42x8mm, FPM (50-306704-00) NB698 ■ 80x98x10mm, FPM (50-319273-00)		NB575 [2]■			
HBS002 Ⓢ (22-29098B) M10x1.25x140mm (x10)	JC824 ■ (31-026334-00) JC281 ■ (31-024312-10) Ⓢ JE120 [213] (31-024767-00)	JN626 (31-026099-10)	JH5005 (x2) [116] (31-027194-00) JJ120 (x2)	PA565 (x8) (50-305900-50) HR342 ■ (24-305900-05/0)	NC006 ■ 35x48x7mm, MVQ (50-319161-00) NB697 ■ 26x42x8mm, FPM (50-306704-00) NB698 ■ 80x98x10mm, FPM (50-319273-00)		NB575 [2]■			
HBS055 Ⓢ (22-29012B) M10x1.25x153mm (x10)	JD5269 ■ (31-027984-00) →12/97 X16XEL JD5229 ■ (31-028463-00) →12/97 X16XEL JD5147 ■ (31-029203-00) 01/98→ JD444 ■ (31-027878-00) X16XEL JD5148 ■ (31-029204-00) Y16XE, Z16SE	JP009 ■ (50-027983-00) →12/97 JP008 ■ (50-027982-00) →12/97 JM5059 (50-029202-00) 01/98→	JJ575 [148] (50-027665-00) →Eng.02MB4997 →Eng.20R22448	HR791 ■ 24-30614-76/0	NC006 ■ (x2) 35x48x7mm, MVQ (50-319161-00) NB697 ■ 26x42x8mm, FPM (50-306704-00) NB698 ■ 80x98x10mm, FPM (50-319273-00)			JC281 JC282 JC436 JC437 JC757 JC824 JD303 JD304 JD444 JD5147 JD5148 JD5196 JD5197 JD5229 JD5269	JP008 JP009 JH5005 JJ120 JJ200 JJ385 JJ575	
HBS074 Ⓢ (22-29100B) M11x1.25x154mm (x10)	JC436 ■ (31-028012-00) JC437 ■ (31-024854-10) Ⓢ JE119 (31-024520-00)	JN693 [128] (31-026198-10)	JJ200 (31-025011-00)	HR343 ■ (24-30602-50/0)	NC006 ■ 35x48x7mm, MVQ (50-319161-00) NB734 ■ 35x50x8mm, FPM NB806 ■ 90x104x11mm, FPM (50-306552-00)		NB575 [2]■			
HBS036 Ⓢ (22-29001B) M12x1.5x102mm (x10)	JD303 ■ JD5914 ■ (31-027778-00) JD304 ■ Ⓢ JE5029 (31-027779-00)	JN777 (50-027776-00)		PA658 (x8) (50-319265-00)	NJ449 40x52x6mm, NBR (50-319266-00) NJ449 ■ 40x52x6mm, NBR (50-319266-00) NK103 ■ 87x100x8.5mm, FPM					
HBS055 Ⓢ (22-29012B) M10x1.25x153mm (x10)	JD5196 ■ (31-029039-00) JD5197 ■ (31-029040-00)	JM5092 (50-029087-00)		PA5025 (x16) (50-319386-00) HR5048 ■ (24-31938-60/0)	NC006 ■ (x2) 35x48x7mm, MVQ (50-319161-00) NC065 ■ 30x40x7mm, FPM (50-306142-00) NB698 ■ 80x98x10mm, FPM (50-319273-00)					
HBS003 Ⓢ (22-29009B) M11x1.25x140mm (x10)	JC757 ■ (31-025817-10) JC282 ■ (31-024625-20) Ⓢ JE120 (31-024767-00)	JN693 [128] (31-026198-10)	JJ385 [148] (50-026131-00)	PA565 (x8) (50-305900-50) HR342 ■ (24-305900-05/0)	NC006 ■ 35x48x7mm, MVQ (50-319161-00) NB700 ■ 31x50x8mm, FPM (50-306551-50) NB806 ■ 90x104x11mm, FPM (50-306552-00)		NB575 [2]■			



KW/PS



Vectra 1.8L i		09/88 → 10/90		266		BP810 (Fibre) (30-025818-10)		DP810 (21-25818-22/0)		EK482 (22-26131-01/0)	
18 SV	1796	4	84.80	Carburettor, SOHC	66/90						
Vectra 1.8L i 16V		10/95 → 09/00		267		AC5460 (MLS) (30-028674-00) X18XE1 BY240 (Fibre) (30-027682-00) X18XE		CC5460 (21-28674-20/0) X18XE1 DY240 (21-27682-21/0) X18XE		EC130 (22-28793-00/0) X18XE HC5007 [212] (22-28386-00/0) X18XE	
X 18 XE1/X 18 XE	1796	4	80.50	MPi, DOHC	85/115						
Vectra 1.9L CDTI Diesel		04/04 →		268		AA5570 (MLS), 0.92mm, 1 Hole (30-029094-10) AA5580 (MLS), 1.02mm, 2 Holes (30-029095-10)		CG7390▲ (21-30144-00/0)		EE5181 (22-29832-01/0)	
Z 19 DT	1910	4	82.00	Direct Injection	74-88/ 100- 120						
Vectra 1.9L CDTI Diesel		04/04 →		269		AD5840 (MLS), 0.82mm, 0 Holes (30-029766-00) AD5850 (MLS), 0.92mm, 1 Hole (30-029767-00) AD5860 (MLS), 1.02mm, 2 Holes (30-029768-00)		CD5840▲ (21-29766-20/0)		EE5181 (22-29832-01/0)	
Z 19 DTH	1910	4	82.00	Direct Injection	88-110/ 120- 150						
Vectra 2.0L		04/88 → 09/89		270		BP820 (Fibre) (30-025819-10)		DP820 (21-25819-21/0)		EK482 (22-26131-01/0)	
C 20 NEF	1998	4	86.00	MPi, SOHC	74/100						
Vectra 2.0L 16V		01/89 → 10/90		271		BS720 (Fibre) (30-026310-10)		DS720 (21-26310-22/0)		ES720 (22-27206-00/0)	
Vectra 2.0L GT 16V											
Vectra 2.0L i 16V											
20 XEJ	1984	4	86.00	MPi, DOHC	110/150						
Vectra 2.0L 16V Turbo		03/03 →		272							
Vectra 2.0L Turbo		10/03 →									
Z 20 NET	1998	4	86.00	Injection	129/175						
Vectra 2.0L DI 16V Diesel		11/96 → 04/02		273		AB5671 (MLS), 1.30mm, 1 Notch AB5681 (MLS), 1.40mm, 2 Notches		CB5670▲■ (21-29011-20/0)		EB5670 (22-29011-00/0)	
X 20 DTL	1995	4	84.00	Direct Injection	60/81						

								
HBS003  (22-29009B) M11x1.25x140mm (x10)	JC757  (31-025817-10) JC282  (31-024625-20)  JE120 (31-024767-00)	JN693 [128] (31-026198-10)	JJ385 (x2) [148] (50-026131-00)	PA565 (x8) (50-305900-50) HR342  (24-30590-05/0)	 NC006  35x48x7mm, MVQ (50-319161-00)  NB700  31x50x8mm, FPM (50-306551-50)  NB806  90x104x11mm, FPM (50-306552-00)	NB575 [2] 	 AA5570, AA5580  JM5159  AC5460  JM5204  BP810  JM950  BP820  JM5092  BS720  JM693  BY240  JP016  JC282  JH5057  JC756  JJ385  JC757  JJ459  JD430  JJ459  JD451  JJ615  JD455  JJ615  JD468  JJ616  JD5196  JD5197  JD5255  JJ617  JD5256  JD5347  JD5376  JE120  JM5092	
HBS054  (22-29013B) M11x1.25x105mm (x10) X18XE HBS055  (22-29012B) M10x1.25x153mm (x10) X18XE1	JD451  (31-027699-00) X18XE JD5196  (31-029039-00) X18XE1 JD450  (31-027684-00) X18XE JD5197  (31-029040-00) X18XE1  JE120 (31-024767-00) X18XE	JM5092 (50-029087-00) X18XE1 JP016 (50-027683-00) X18XE	JJ615 (31-028793-00) X18XE JJ616  [212] (31-028386-00) X18XE JJ617  [212] (31-028385-00) X18XE	PA5025 (x16) (50-319386-00) X18XE1 HR5048  [212] (24-31938-60/0) X18XE1 HR791  [212] 24-30614-76/0 X18XE	 NC006  (x2) 35x48x7mm, MVQ (50-319161-00)  NC065  30x40x7mm, FPM (50-306142-00) X18XE1  NB700  31x50x8mm, FPM (50-306551-50) X18XE  NB698  80x98x10mm, FPM (50-319273-00) X18XE1  NB806  90x104x11mm, FPM (50-306552-00) X18XE			
HBS227  (22-17018B) M12x1.25x218mm (x10)	JD468  (31-028377-00) (MLS)	JM5204 (50-029935-00)		HR363 	 NA5053 30x42x7mm, FPM (50-319488-00)  NA5070  31x41x7mm, FPM (50-319524-00)	HL5031 [245] 		
HBS370  (22-17026B) M12x1.25x225mm (x10)	JD5376  (31-029969-00)	JM7055 (Steel Elastomer)		HR5095 	 NA5053 30x42x7mm, FPM (50-319488-00)  NA5070  31x41x7mm, FPM (50-319524-00)	HL5031 [245] 		
HBS003  (22-29009B) M11x1.25x140mm (x10)	JC756  (31-025820-20) JC282  (31-024625-20)	JN693 [128] (31-026198-10)	JJ385 [148] (50-026131-00)	PA565 (x8) (50-305900-50) HR342  (24-30590-05/0)	 NC006  35x48x7mm, MVQ (50-319161-00)  NB700  31x50x8mm, FPM (50-306551-50)  NB806  90x104x11mm, FPM (50-306552-00)	NB575 [2]  NB807 [2] 		
HBS035  (22-29005B) M11x1.25x110mm (x10) →Eng.14137011 HBS054  (22-29013B) M11x1.25x105mm (x10) Eng.14137012→	JD455  (31-026335-10) JD430  (31-025888-00)	JM950 (50-026336-10)	JJ459 (x2) [148] (31-027206-00)	HR342  (x2) (24-30590-05/0)	 NC006  (x2) 35x48x7mm, MVQ (50-319161-00)  NB884  38x50x5.5mm, FPM (50-319010-00)  NB806  90x104x11mm, FPM (50-306552-00)	NB575 [2] 		
HBS416  (22-29025B) M11x1.50x163mm (x10)			HR397 [57] 34-000410-00		 NA5108  42x55x7mm, FPM (50-319392-00)  NB806  90x104x11mm, FPM (50-306552-00)			
HBS298  (22-29016B) M12x1.50x235mm (x10)	JD5255  (31-029721-00) JD5347   (31-029942-00) JD5256  (31-029722-00)	JM5159 (50-029633-00)	JH5057 (31-029575-00)	HR791  24-30614-76/0	 NA5069  55x68x8mm, FPM (50-319515-00)  NA5209  99x114x11mm, FPM (50-319514-00)			







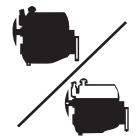



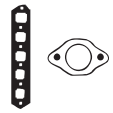

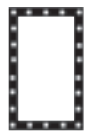

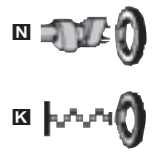





























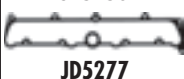
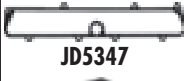

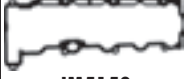



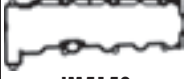

OPEL



KW/PS



Vectra 2.0L DTI Diesel 10/03 → 274						AB5671 (MLS), 1.30mm, 1 Notch AB5681 (MLS), 1.40mm, 2 Notches	CB5671 ▲■ (21-29011-21/0)	EB5670 (22-29011-00/0)
Vectra 2.0L DTI 16V Diesel 04/02 →								
Y 20 DTH	1995	4	84.00	Direct Injection	74/100			
Vectra 2.0L DTI 16V Diesel 06/97 → 07/03 275						AB5671 (MLS), 1.30mm, 1 Notch AB5681 (MLS), 1.40mm, 2 Notches	CB5670 ▲■ (21-29011-20/0) X20DTH CB5671 ▲■ (21-29011-21/0) Y20DTH	EB5670 (22-29011-00/0)
X 20 DTH/Y 20 DTH 1995 4 84.00 Direct Injection 74/100								
Vectra 2.0L GT 16V 02/90 → 11/95 276 Vectra 2.0L GT 16V 4x4 02/90 → 11/95 Vectra 2.0L i 16V 02/90 → 11/95						BS720 (Fibre) (30-026310-10)	DS720 (21-26310-22/0)	ES720 (22-27206-00/0)
C 20 XE 1998 4 86.00 MPi, DOHC 110/150								
Vectra 2.0L i 09/88 → 11/95 277 Vectra 2.0L i 4x4 01/89 → 11/95 Vectra 2.0L i GT 09/88 → 11/95						BP820 (Fibre) (30-025819-10)	DP820 (21-25819-21/0)	EK482 (22-26131-01/0)
20 NE/C 20 NE 1998 4 86.00 MPi, SOHC 85/115 20 SEH 1998 4 86.00 MPi, SOHC 95/129								
Vectra 2.0L i 10/95 → 04/02 278						BP820 (Fibre) (30-025819-10)	DP820 (21-25819-21/0)	HC5007 (22-28386-00/0)
20 NEJ 1998 4 86.00 Injection, SOHC 82/111								
Vectra 2.0L i 16V 06/94 → 09/00 279 Vectra 2.0L i 16V 4x4 06/94 → 11/95						BY250 (Fibre) (30-027987-10)	DY250 (21-27987-20/0)	EC130 (22-28793-00/0) HC5007 [212] (22-28386-00/0)
C 20 SEL/X 20 XEV 1998 4 86.00 Injection, DOHC 100/136								
Vectra 2.0L i Turbo 4x4 06/94 → 11/95 280						BY260 (Fibre) (30-027427-00)	DY260 (21-27427-21/0)	ES720 (22-27206-00/0)
C 20 LET 1998 4 86.00 MPi, DOHC 150/204								
Vectra 2.2L 16V 04/02 → 281 Vectra 2.2L i 16V 09/00 → 07/03						AG9580 (MLS) (30-030344-00)	CG9580 (21-30344-00/0)	
Z 22 SE 2198 4 86.00 Injection, DOHC 108/147								











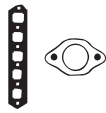

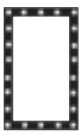

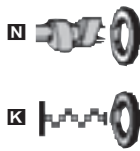









































































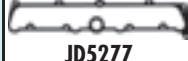

								
HBS298 Ⓢ [22-29016B] M12x1.50x235mm (x10)	JD5255 ■ (31-029721-00) JD5277 ■ ■ (31-029723-00) JD5256 ■ (31-029722-00)	JM5159 (50-029633-00)	JH5057 (31-029575-00)	HR791 ■ 24-30614-76/0	NA5069 ■ 55x68x8mm, FPM (50-319515-00) NA5209 ■ 99x114x11mm, FPM (50-319514-00)			 BP820  BS720  BY250  BY260  JC282  JC756  JD430  JD451  JD455  JD456  JD5255  JD5256  JD5277  JD5347  JE120  JM5159  JM950  JN693  JP016  JH5057
HBS298 Ⓢ [22-29016B] M12x1.50x235mm (x10)	JD5255 ■ (31-029721-00) JD5277 ■ ■ (31-029723-00) Y20DTH JD5347 ■ ■ (31-029942-00) X20DTH JD5256 ■ (31-029722-00)	JM5159 (50-029633-00)	JH5057 (31-029575-00)	HR791 ■ 24-30614-76/0	NA5069 ■ 55x68x8mm, FPM (50-319515-00) NA5209 ■ 99x114x11mm, FPM (50-319514-00)			 JJ385  JJ459  JJ615  JJ616  JJ617
HBS035 Ⓢ [22-29005B] M11x1.25x110mm (x10) →Eng.14003804 HBS054 Ⓢ [22-29013B] M11x1.25x105mm (x10) Eng.14003805→	JD455 ■ (31-026335-10) JD430 ■ (31-025888-00)	JM950 (50-026336-10)	JJ459 (x2) [148] (31-027206-00)	PA565 (x16) (50-305900-50) HR342 ■ (x2) (24-30590-05/0)	NC006 ■ (x2) 35x48x7mm, MVQ (50-319161-00) NB884 ■ 38x50x5.5mm, FPM (50-319010-00) NB806 ■ 90x104x11mm, FPM (50-306552-00)	NB575 [2]■ NB807 [2]■		 NB575  NB807  NB806  NB884  NC006
HBS003 Ⓢ [22-29009B] M11x1.25x140mm (x10)	JC756 ■ (31-025820-20) JC282 ■ (31-024625-20) ☉JE120 (31-024767-00)	JN693 [128] (31-026198-10)	JJ385 [148] (50-026131-00)	PA565 (x8) (50-305900-50) HR342 ■ (24-30590-05/0)	NC006 ■ 35x48x7mm, MVQ (50-319161-00) NB700 ■ 31x50x8mm, FPM (50-306551-50) NB806 ■ 90x104x11mm, FPM (50-306552-00)	NB575 [2]■ NB807 [2]■		 NB575  NB807  NB700  NB806
HBS003 Ⓢ [22-29009B] M11x1.25x140mm (x10)	JC756 ■ (31-025820-20) JC282 ■ (31-024625-20) ☉JE120 (31-024767-00)	JN693 [128] (31-026198-10)	JJ616 ■ (31-028386-00) JJ617 ■ (31-028385-00)	PA565 (x8) (50-305900-50) HR342 ■ (24-30590-05/0)	NC006 ■ 35x48x7mm, MVQ (50-319161-00) NB700 ■ 31x50x8mm, FPM (50-306551-50) NB806 ■ 90x104x11mm, FPM (50-306552-00)	NB807 [2]■		 NB807  JE120  JM5159  JM950
HBS054 Ⓢ [22-29013B] M11x1.25x105mm (x10)	JD451 ■ (31-027699-00) JD450 ■ (31-027684-00) ☉JE120 (31-024767-00)	JP016 (50-027683-00)	JJ615 (31-028793-00) JJ616 ■ [212] (31-028386-00) JJ617 ■ [212] (31-028385-00)	HR791 ■ 24-30614-76/0	NC006 ■ (x2) 35x48x7mm, MVQ (50-319161-00) NB700 ■ 31x50x8mm, FPM (50-306551-50) NB806 ■ 90x104x11mm, FPM (50-306552-00)			 JP016  JM5159  JM950  JN693  JP016
HBS035 Ⓢ [22-29005B] M11x1.25x110mm (x10) →Eng.14003804 HBS054 Ⓢ [22-29013B] M11x1.25x105mm (x10) Eng.14003805→	JD455 ■ (31-026335-10) JD456 ■ (31-027459-00)	JM950 (50-026336-10)	JJ459 (x2) [148] (31-027206-00)	PA565 (x16) (50-305900-50) HR342 ■ (x2) (24-30590-05/0)	NC006 ■ (x2) 35x48x7mm, MVQ (50-319161-00) NB884 ■ 38x50x5.5mm, FPM (50-319010-00) NB806 ■ 90x104x11mm, FPM (50-306552-00)	NB807 [2]■		 NB807  NB884  NB806
HBS416 Ⓢ [22-29025B] M11x1.50x163mm (x10)	KG5337 ■ (50-350435-00) (MVQ) JD5868 ■ (31-030346-00)				NA5108 ■ 42x55x7mm, FPM (50-319392-00) NB806 ■ 90x104x11mm, FPM (50-306552-00)			 NA5108  NB806



KW/PS



Model				Year Range	Power (kW/PS)	Engine Details	Accessories
Vectra 2.2L direct				10/03 →	282	AG9590 (MLS) (30-030345-00)	CG9590 (21-30345-00/0)
Z 22 YH	2198	4	86.00	Injection, DOHC	110-114/ 150-155		
Vectra 2.2L direct				10/03 →	283	AG9590 (MLS) (30-030345-00)	CG9590 (21-30345-00/0)
Z 22 YH	2198	4	86.00	Injection, DOHC	110-114/ 150-155		
Vectra 2.2L DTi Diesel				10/03 →	284	AB5671 (MLS), 1.30mm, 1 Notch	CB5671▲■ (21-29011-21/0)
Vectra 2.2L DTi 16V Diesel				04/02 →		AB5681 (MLS), 1.40mm, 2 Notches	EB5670 (22-29011-00/0)
Y 22 DTR	2172	4	84.00	Direct Injection, SOHC	92/125		
Vectra 2.2L DTi 16V Diesel				09/00 → 07/03	285	AB5671 (MLS), 1.30mm, 1 Notch	CB5670▲■ (21-29011-20/0)
Y 22 DTR	2172	4	84.00	Direct Injection, SOHC	92/125	AB5681 (MLS), 1.40mm, 2 Notches	EB5670 (22-29011-00/0)
Vectra 2.5L i 500 2.5L				05/98 → 09/00	286	BY270 (Fibre) (x2) (30-027690-00)	DY272 (21-27690-22/0) 10/95 → 09/00
Vectra 2.5L i V6				10/95 → 09/00			EY300
X 25 XE	2498	6	81.60	Injection, DOHC, V6	125/170		
Vectra 2.5L V6				02/93 → 11/95	287	BY270 (Fibre) (x2) (30-027690-00)	DY270 (21-27690-20/0)
C 25 XE	2498	6	81.60	Injection, DOHC, V6	125/170		
Vectra 2.6L i V6				09/00 → 07/03	288		
Y 26 SE	2597	6	83.20	Injection, DOHC, V6	125-132/ 170-180		
Vectra 3.0L CDTi Diesel				06/03 →	289	AG9770 (MLS), 0.60mm, 1 Hole <input checked="" type="checkbox"/> AG9780 (MLS), 0.65mm, 2 Holes <input checked="" type="checkbox"/> AG9790 (MLS), 0.70mm, 3 Holes <input checked="" type="checkbox"/> AG9800 (MLS), 0.60mm, 1 Hole <input checked="" type="checkbox"/> AG9810 (MLS), 0.65mm, 2 Holes <input checked="" type="checkbox"/> AG9820 (MLS), 0.70mm, 3 Holes <input checked="" type="checkbox"/>	CG9770▲ EG9770 FG9770▲
Y 30 DT	2958	6	87.50	Direct Injection, V6	130/177		
Z 30 DT	2958	6	87.50	Direct Injection, V6	135/184		
Vectra 3.0L CDTi Diesel				08/05 →	290	AG9770 (MLS), 0.60mm, 1 Hole <input checked="" type="checkbox"/> AG9780 (MLS), 0.65mm, 2 Holes <input checked="" type="checkbox"/> AG9790 (MLS), 0.70mm, 3 Holes <input checked="" type="checkbox"/> AG9800 (MLS), 0.60mm, 1 Hole <input checked="" type="checkbox"/> AG9810 (MLS), 0.65mm, 2 Holes <input checked="" type="checkbox"/> AG9820 (MLS), 0.70mm, 3 Holes <input checked="" type="checkbox"/>	CG9770▲ EG9770 FG9770▲
Z 30 DT	2958	6	87.50	Direct Injection, V6	135/184		

								 BY270
								 JD457
HBS416  (22-29025B) M11x1.50x163mm (x10)	JD5869  (x3) (31-030358-00) JD5870  (31-030359-00) JD5868  (31-030346-00)							 JD458
HBS416  (22-29025B) M11x1.50x163mm (x10)	JD5869  (x3) (31-030358-00) JD5870  (31-030359-00) JD5868  (31-030346-00)							 JD459
HBS298  (22-29016B) M12x1.50x235mm (x10)	JD5255  (31-029721-00) JD5277   (31-029723-00) JD5256  (31-029722-00)	JM5159 (50-029633-00)	JH5057 (31-029575-00)	HR791  24-30614-76/0	NA5069  55x68x8mm, FPM (50-319515-00) NA5209  99x114x11mm, FPM (50-319514-00)			 JD5201
HBS298  (22-29016B) M12x1.50x235mm (x10)	JD5255  (31-029721-00) JD5347   (31-029942-00) JD5256  (31-029722-00)	JM5159 (50-029633-00)	JH5057 (31-029575-00)	HR791  24-30614-76/0	NA5069  55x68x8mm, FPM (50-319515-00) NA5209  99x114x11mm, FPM (50-319514-00)			 JD5202
HBS164  (22-29011B) M11x1.25x105mm (x16)	JD5202  (x2) (50-027980-00) JD5203   (x3) (50-027979-00) JD459  (x2) (31-027698-00)	JD5204 (x2) (50-028690-00)	JJ573  (50-027851-00) JJ572  (50-027852-00)	HR5062  24-30614-73/0	NC006 (x4) 35x48x7mm, MVQ (50-319161-00) NB884  38x50x5.5mm, FPM (50-319010-00) NB806  90x104x11mm, FPM (50-306552-00)			 JD5203
HBS164  (22-29011B) M11x1.25x105mm (x16)	JD5201  (31-027700-00) JD458   (31-027688-00) JD457   (x2) (31-027686-00) JD459  (x2) (31-027698-00)	JM5095  (50-027697-00) JM5094  (50-027696-00) HM5294  (24-27696-00/0)	JH5052 (31-027689-00)	HR5062  24-30614-73/0	NC006 (x4) 35x48x7mm, MVQ (50-319161-00) NB884  38x50x5.5mm, FPM (50-319010-00) NB806  90x104x11mm, FPM (50-306552-00)			 JD5205
HBS164  (22-29011B) M11x1.25x105mm (x16)	JD5202  (x2) (50-027980-00) JD5203   (x3) (50-027979-00)	JD5204 (x2) (50-028690-00)		HR5062  24-30614-73/0	NC006 (x4) 35x48x7mm, MVQ (50-319161-00) NB884  38x50x5.5mm, FPM (50-319010-00) NB806  90x104x11mm, FPM (50-306552-00)			 JD5255
	JD5897  (Steel Elastomer) JD5896   JE5064 (Steel)	HM5292 		HR5094 				 JD5256
	JD5897  (Steel Elastomer) JD5896   JE5064 (Steel)	HM5292 		HR5094 				 JD5277
								 JD5347
								 JD5256
								 JD5204
								 JM5094
								 JM5095
								 JM5159
								 JH5052
								 JH5057
								 JJ572
								 JJ573



KW/PS

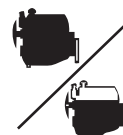

Vectra 3.2L V6				08/02 →	291			
Z 32 SE	3175	6	88.50	Injection, DOHC, V6	155/211			
Vivaro 1.9L DI Diesel				08/01 →	292	AC5070 (Fibre), 1.35mm, 2 Notches (30-029474-00)	CC5060▲ (21-29483-20/0)	EC5060 (22-29474-00/0)
Vivaro 1.9L DTI Diesel				08/01 →				
F9Q 774	1870	4	80.00	Direct Injection	60/81	→+0.653mm		
F9Q 760	1870	4	80.00	Direct Injection, SOHC	74/100	→0.653→+0.786mm		
Vivaro 1.9L DTI Diesel				08/01 →	293	AC5070 (Fibre), 1.35mm, 2 Notches (30-029474-00)	CC5060▲ (21-29483-20/0)	EC5060 (22-29474-00/0)
F9Q762	1870	4	80.00	Direct Injection	59-60/ 80-82	→+0.653mm		
Vivaro 2.0L 16V				08/01 →	294	AD5990 (MLS) (30-029781-00)	CD5991	ED5991
F4R 720	1998	4	82.70	DOHC	88/120			
Vivaro 2.5L DTI Diesel				05/03 →	295	AE5220 (MLS) (30-029037-00)		EE5220 (22-29037-00/0)
G9U 730	2463	4	89.00	Direct Injection	99/135			
Zafira 1.6L				07/05 →	296	AE5930 (MLS) (30-029999-00)	CE5930 (21-29999-20/0)	
Z 16 XEP	1598	4	79.00	Injection, DOHC	74-77/ 101- 105			
Zafira 1.6L 16V				04/99 →06/05	297	AB5540 (MLS) (30-029209-00)	CB5540 (21-29209-20/0)	EY230 (22-27665-01/0)
Z 16 XE	1598	4	79.00	MPI, DOHC	74/100	Z16XE	Z16XE	→Eng.02MB4997
X 16 XEL	1598	4	79.00	Injection, DOHC	74/78/ 100/ 106	AY220 (Fibre) X16XEL	DY232 (21-27986-25/0)	→Eng.20R22448
Zafira 1.6L CNG				09/01 →06/05	298	AB5540 (MLS) (30-029209-00)	CB5540 (21-29209-20/0)	EB541 [8] (22-27665-03/0)
Z 16 YNG	1598	4	79.00	Injection, DOHC	69-74/ 94-101		X16XEL	Eng.02MB4998→ Eng.20R22449→
Zafira 1.8L 16V				04/99 →09/00	299	AC5460 (MLS) (30-028674-00)	CC5460 (21-28674-20/0)	
X 18 XE1	1796	4	80.50	MPI, DOHC	85/115			
Zafira 1.8L 16V				09/00 →06/05	300	AC5460 (MLS) (30-028674-00)	CC5460 (21-28674-20/0)	
Z 18 XE	1796	4	80.50	MPI, DOHC	92/125			

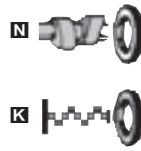
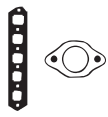

AB5540



AC5070, AC5080,
AC5090



AC5460



AE5220



AE5930



AY220



JD444



JD5147



JD5148



JD5196



JD5197



JD5400

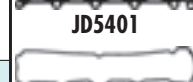

JD5401



JM5059



JM5092



JM5235

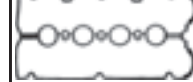

JJ575











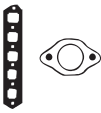

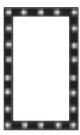

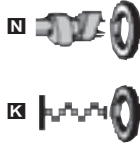









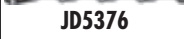

































HBS164 Ⓢ (22-29011B) M11x1.25x105mm (x16)		JM5071 (50-029232-00)				
HBS120 Ⓢ (22-51008B) M12x1.50x118mm (x10)	JD5189	JM5089 Ⓢ	JH5041 ● KG5012 16x23x1.5mm	HR646 Ⓢ 24-30670-60/0	☒ NF846 25x42x7mm, FPM/ACM (50-319516-00) ☒ NA5036 Ⓢ 42x54x6mm, FPM (50-319473-00) ☒ NF850 Ⓢ 85x105x8mm, FPM (50-319183-00)	HL5017 [245]Ⓢ
HBS120 Ⓢ (22-51008B) M12x1.50x118mm (x10) → Eng.C000156 HBS372 Ⓢ (22-51109B) M12x1.50x121mm (x10) Eng.C000157→	JD5189	JM5089 Ⓢ	JH5041 ● KG5012 16x23x1.5mm	HR646 Ⓢ 24-30670-60/0	☒ NF846 25x42x7mm, FPM/ACM (50-319516-00) ☒ NA5036 Ⓢ 42x54x6mm, FPM (50-319473-00) ☒ NF850 Ⓢ 85x105x8mm, FPM (50-319183-00)	HL5017 [245]Ⓢ
HBS310 Ⓢ (22-51108B) M12x1.50x117mm (x10)		HR397 [57] 34-000410-00			☒ NA5257 28x47x5.5mm	
HBS373 Ⓢ (22-51110B) M12x1.50x131mm (x10)						
HBS055 Ⓢ (22-29012B) M10x1.25x153mm (x10)	JD5400 Ⓢ (31-030002-00) JD5401 Ⓢ (31-030004-00)	JM5235 (50-029985-00)		HR5087 Ⓢ (24-31951-90/0)	☒ NC006 Ⓢ (x2) 35x48x7mm, MVQ (50-319161-00) ☒ NA5174 Ⓢ 31.5x42x7mm, FPM (50-319469-00) ☒ NB698 Ⓢ 80x98x10mm, FPM (50-319273-00)	
HBS055 Ⓢ (22-29012B) M10x1.25x153mm (x10)	JD5147 Ⓢ (31-029203-00) JD444 Ⓢ (31-027878-00) X16XEL JD5148 Ⓢ (31-029204-00) Z16XE	JM5059 (50-029202-00)	JJ575 [148] (50-027665-00) → Eng.02MB4997 → Eng.20R22448	HR791 Ⓢ 24-30614-76/0	☒ NC006 Ⓢ (x2) 35x48x7mm, MVQ (50-319161-00) ☒ NB697 Ⓢ 26x42x8mm, FPM (50-306704-00) ☒ NB698 Ⓢ 80x98x10mm, FPM (50-319273-00)	
HBS055 Ⓢ (22-29012B) M10x1.25x153mm (x10)	JD5147 Ⓢ (31-029203-00) JD5148 Ⓢ (31-029204-00)	JM5059 (50-029202-00)		HR280 Ⓢ 24-30614-75/0	☒ NC006 Ⓢ (x2) 35x48x7mm, MVQ (50-319161-00) ☒ NB697 Ⓢ 26x42x8mm, FPM (50-306704-00) ☒ NB698 Ⓢ 80x98x10mm, FPM (50-319273-00)	
HBS055 Ⓢ (22-29012B) M10x1.25x153mm (x10)	JD5196 Ⓢ (31-029039-00) JD5197 Ⓢ (31-029040-00)	JM5092 (50-029087-00)		HR5048 Ⓢ (24-31938-60/0)	☒ NC006 Ⓢ (x2) 35x48x7mm, MVQ (50-319161-00) ☒ NC065 Ⓢ 30x40x7mm, FPM (50-306142-00) ☒ NB698 Ⓢ 80x98x10mm, FPM (50-319273-00)	
HBS055 Ⓢ (22-29012B) M10x1.25x153mm (x10)	JD5196 Ⓢ (31-029039-00) JD5197 Ⓢ (31-029040-00)	JM5092 (50-029087-00)		PA5025 (x16) (50-319386-00) HR5048 Ⓢ (24-31938-60/0)	☒ NC006 Ⓢ (x2) 35x48x7mm, MVQ (50-319161-00) ☒ NC065 Ⓢ 30x40x7mm, FPM (50-306142-00) ☒ NB698 Ⓢ 80x98x10mm, FPM (50-319273-00)	



















KW/PS



Zafira 1.9L CDTI Diesel				07/05 →	301	AD5840 (MLS), 0.82mm, 0 Holes (30-029766-00)	CD5840▲ (21-29766-20/0)	EE5181 (22-29832-01/0)
Z 19 DTH	1910	4	82.00	Direct Injection	88-110/ 120- 150	AD5850 (MLS), 0.92mm, 1 Hole (30-029767-00)		
						AD5860 (MLS), 1.02mm, 2 Holes (30-029768-00)		
Zafira 1.9L CDTI Diesel				07/05 →	302	AA5570 (MLS), 0.92mm, 1 Hole (30-029094-10)	CG7390▲ (21-30144-00/0)	EE5181 (22-29832-01/0)
Z 19 DT	1910	4	82.00	Direct Injection	74-88/ 100- 120	AA5580 (MLS), 1.02mm, 2 Holes (30-029095-10)		
Zafira 2.0L				07/05 →	303	AG9570 (MLS) (30-030342-00)	CG9570 (21-30342-00/0)	EG9570
Zafira 2.0L OPC				09/01 →06/05				
Z 20 LET	1998	4	86.00	Injection, DOHC	140- 147/ 190- 200			
Z 20 LER	1998	4	86.00	Injection, DOHC	147/200			
Zafira 2.0L				01/06 →	304			EG9570
Z 20 LEH	1998	4	86.00	Injection	177/240			
Zafira 2.0L DI 16V Diesel				10/99 →06/05	305	AB5671 (MLS), 1.30mm, 1 Notch	CB5670▲■ (21-29011-20/0)	EB5670 (22-29011-00/0)
X 20 DTL	1995	4	84.00	Direct Injection	60/81	AB5681 (MLS), 1.40mm, 2 Notches		
Zafira 2.0L DTI 16V Diesel				09/00 →06/05	306	AB5671 (MLS), 1.30mm, 1 Notch	CB5671▲■ (21-29011-21/0)	EB5670 (22-29011-00/0)
Y 20 DTH	1995	4	84.00	Direct Injection	74/100	AB5681 (MLS), 1.40mm, 2 Notches		
Zafira 2.2L				07/05 →	307	AG9590 (MLS) (30-030345-00)	CG9590 (21-30345-00/0)	
Z 22 YH	2198	4	86.00	Injection, DOHC	110- 114/ 150- 155			
Zafira 2.2L 16V				09/00 →06/05	308	AG9580 (MLS) (30-030344-00)	CG9580 (21-30344-00/0)	
Z 22 SE	2198	4	86.00	Injection, DOHC	108/147			
Zafira 2.2L DTI 16V Diesel				01/02 →06/05	309	AB5671 (MLS), 1.30mm, 1 Notch	CB5671▲■ (21-29011-21/0)	EB5670 (22-29011-00/0)
Y 22 DTR	2172	4	84.00	Direct Injection, SOHC	92/125	AB5681 (MLS), 1.40mm, 2 Notches		

								 AA5570, AA5580  JD451  JD468  JD5255  JD5256  JD5277  JD5347  JD5376  JM5159  JM5204  JP016  JH5057  JJ616  JJ617
HBS370  (22-17026B) M12x1.25x225mm (x10)	JD5376  (31-029969-00)	JM5204 (50-029935-00) JM7055 (Steel Elastomer)		HR363  HR5095 	NA5053 30x42x7mm, FPM (50-319488-00) NA5070 31x41x7mm, FPM (50-319524-00)	HL5031 [245] 		
HBS227  (22-17018B) M12x1.25x218mm (x10)	JD468  (31-028377-00) (MLS)	JM5204 (50-029935-00)		HR363 	NA5053 30x42x7mm, FPM (50-319488-00) NA5070 31x41x7mm, FPM (50-319524-00)	HL5031 [245] 		
HBS054  (22-29013B) M11x1.25x105mm (x10)	JD451  (31-027699-00) JD5903  (31-030367-00) (MLS)	JP016 (50-027683-00)	JJ616  (31-028386-00) JJ617  (31-028385-00)	HR791  24-30614-76/0	NC006 (x2) 35x48x7mm, MVQ (50-319161-00) NB700 31x50x8mm, FPM (50-306551-50) NB806 90x104x11mm, FPM (50-306552-00)			
HBS054  (22-29013B) M11x1.25x105mm (x10)	JD5903  (31-030367-00) (MLS)				NC006 35x48x7mm, MVQ (50-319161-00) NB700 31x50x8mm, FPM (50-306551-50) NB806 90x104x11mm, FPM (50-306552-00)			
HBS298  (22-29016B) M12x1.50x235mm (x10)	JD5255  (31-029721-00) JD5347  (31-029942-00) JD5256  (31-029722-00)	JM5159 (50-029633-00)	JH5057 (31-029575-00)	HR791  24-30614-76/0	NA5069 55x68x8mm, FPM (50-319515-00) NA5209 99x114x11mm, FPM (50-319514-00)			
HBS298  (22-29016B) M12x1.50x235mm (x10)	JD5255  (31-029721-00) JD5277  (31-029723-00) JD5256  (31-029722-00)	JM5159 (50-029633-00)	JH5057 (31-029575-00)	HR791  24-30614-76/0	NA5069 55x68x8mm, FPM (50-319515-00) NA5209 99x114x11mm, FPM (50-319514-00)			
HBS416  (22-29025B) M11x1.50x163mm (x10)	JD5870  (31-030359-00) JD5868  (31-030346-00)		HR397 [57] 34-000410-00		NA5108 42x55x7mm, FPM (50-319392-00) NB806 90x104x11mm, FPM (50-306552-00)			
HBS416  (22-29025B) M11x1.50x163mm (x10)	KG5337  (50-350435-00) (MVQ) JD5868  (31-030346-00)				NA5108 42x55x7mm, FPM (50-319392-00) NB806 90x104x11mm, FPM (50-306552-00)			
HBS298  (22-29016B) M12x1.50x235mm (x10)	JD5255  (31-029721-00) JD5277  (31-029723-00) JD5256  (31-029722-00)	JM5159 (50-029633-00)	JH5057 (31-029575-00)	HR791  24-30614-76/0	NA5069 55x68x8mm, FPM (50-319515-00) NA5209 99x114x11mm, FPM (50-319514-00)			

		CC			9			CC			9
1KR (384 F)	Petrol	998	3	71.00	20	ES9A (XFV)	Petrol	2946	6	87.00	132
220A2 (160A)	Petrol	1581	4	86.40	202	ES9A (XFV)	Petrol	2946	6	87.00	169
8140.43S	Diesel	2798	4	94.40	201	ES9J4 (XFZ)	Petrol	2946	6	87.00	125
8140.63	Diesel	2798	4	94.40	200	ES9J4S (XFX/XFW)	Petrol	2946	6	87.00	126
CRD93 (U25/651/661)	Diesel	2500	4	93.00	215	ES9J4S (XFX/XFW)	Petrol	2946	6	87.00	168
CRD93 (U25/651/661)	Diesel	2500	4	93.00	216	ES9J4S (XFX/XFW)	Petrol	2946	6	87.00	185
CRD93L	Diesel	2498	4	93.00	147	EW10A (RFJ)	Petrol	1997	4	85.00	130
CRD93LS (U25/673)	Diesel	2500	4	93.00	147	EW10A (RFJ)	Petrol	1997	4	85.00	180
CRD93LS (U25/673)	Diesel	2500	4	93.00	217	EW10A (RFJ)	Petrol	1997	4	85.00	82
DJ5 (T9A)	Diesel	2446	4	92.00	198	EW10D (RLZ)	Petrol	1997	4	85.00	116
DJ5T (T8A/THZ)	Diesel	2446	4	92.00	198	EW10J4 (RFN)	Petrol	1997	4	85.00	116
DJ5TED (THX)	Diesel	2446	4	92.00	199	EW10J4 (RFN)	Petrol	1997	4	85.00	130
DK5ATE (THY)	Diesel	2446	4	92.00	159	EW10J4 (RFN)	Petrol	1997	4	85.00	162
DV4TD (8HX)	Diesel	1398	4	73.70	188	EW10J4 (RFN)	Petrol	1997	4	85.00	174
DV4TD (8HX)	Diesel	1398	4	73.70	45	EW10J4 (RFN)	Petrol	1997	4	85.00	179
DV4TD (8HX)	Diesel	1398	4	73.70	78	EW10J4 (RFN)	Petrol	1997	4	85.00	207
DV4TD (8HZ)	Diesel	1398	4	73.70	188	EW10J4 (RFN)	Petrol	1997	4	85.00	50
DV4TD (8HZ)	Diesel	1398	4	73.70	45	EW10J4 (RFN)	Petrol	1997	4	85.00	81
DV4TD (8HZ)	Diesel	1398	4	73.70	78	EW10J4 (RFR)	Petrol	1997	4	85.00	116
DV6ATED4 (9HX)	Diesel	1560	4	75.00	55	EW10J4 (RFR)	Petrol	1997	4	85.00	50
DV6ATED4 (9HX)	Diesel	1560	4	75.00	80	EW10J4S (RFK)	Petrol	1997	4	85.00	50
DV6TED4 (9HY)	Diesel	1560	4	75.00	127	EW10J4S (RFK)	Petrol	1997	4	85.00	81
DV6TED4 (9HY)	Diesel	1560	4	75.00	47	EW10J4S (RFK)	Petrol	1997	4	85.00	82
DV6TED4 (9HY)	Diesel	1560	4	75.00	55	EW12J4 (3FY)	Petrol	2230	4	86.00	131
DV6TED4 (9HY)	Diesel	1560	4	75.00	80	EW12J4 (3FY)	Petrol	2230	4	86.00	166
DV6TED4 (9HZ)	Diesel	1560	4	75.00	190	EW12J4 (3FZ)	Petrol	2230	4	86.00	123
DV6TED4 (9HZ)	Diesel	1560	4	75.00	47	EW12J4 (3FZ)	Petrol	2230	4	86.00	131
DV6TED4 (9HZ)	Diesel	1560	4	75.00	55	EW12J4 (3FZ)	Petrol	2230	4	86.00	165
DW10ATED (RHS)	Diesel	1997	4	85.00	119	EW12J4 (3FZ)	Petrol	2230	4	86.00	183
DW10ATED (RHS)	Diesel	1997	4	85.00	163	EW7A (6FY)	Petrol	1749	4	82.70	128
DW10ATED (RHS)	Diesel	1997	4	85.00	83	EW7J4 (6FZ)	Petrol	1749	4	82.70	112
DW10ATED (RHZ)	Diesel	1997	4	85.00	118	EW7J4 (6FZ)	Petrol	1749	4	82.70	128
DW10ATED (RHZ)	Diesel	1997	4	85.00	119	F1	Petrol	1118	4	74.00	26
DW10ATED (RHZ)	Diesel	1997	4	85.00	163	G1 / G2	Petrol	1294	4	76.70	27
DW10ATED (RHZ)	Diesel	1997	4	85.00	175	G1 / G2	Petrol	1294	4	76.70	88
DW10ATED (RHZ)	Diesel	1997	4	85.00	208	KFU (ET3J4)	Petrol	1360	4	75.00	187
DW10ATED4 (RHM)	Diesel	1997	4	85.00	182	KFU (ET3J4)	Petrol	1360	4	75.00	44
DW10ATED4 (RHT)	Diesel	1997	4	85.00	182	KFU (ET3J4)	Petrol	1360	4	75.00	52
DW10ATED4 (RHW)	Diesel	1997	4	85.00	176	KFU (ET3J4)	Petrol	1360	4	75.00	77
DW10ATED4 (RHW)	Diesel	1997	4	85.00	182	N9T	Petrol	2155	4	91.70	144
DW10ATED4 (RHW)	Diesel	1997	4	85.00	210	N9TE (176B)	Petrol	2155	4	91.70	144
DW10BTED (RHX)	Diesel	1997	4	85.00	209	N9TE (176X)	Petrol	2155	4	91.70	144
DW10BTED4 (RHR)	Diesel	1997	4	85.00	129	TU 3	Petrol	1360	4	75.00	99
DW10BTED4 (RHR)	Diesel	1997	4	85.00	164	TU1 (H1A/H1B/H3A)	Petrol	1124	4	72.00	25
DW10BTED4 (RHR)	Diesel	1997	4	85.00	181	TU1 (H1A/H1B/H3A)	Petrol	1124	4	72.00	9
DW10BTED4 (RHR)	Diesel	1997	4	85.00	211	TU1JP (HFX)	Petrol	1124	4	72.00	10
DW10BTED4 (RHR)	Diesel	1997	4	85.00	83	TU1JP (HFX)	Petrol	1124	4	72.00	224
DW10BTED4 (RHR)	Diesel	1997	4	85.00	85	TU1JP (HFX)	Petrol	1124	4	72.00	42
DW10TD (RHY)	Diesel	1997	4	85.00	120	TU1JP (HFZ)	Petrol	1124	4	72.00	42
DW10TD (RHY)	Diesel	1997	4	85.00	231	TU1M (HDY)	Petrol	1124	4	72.00	11
DW10TD (RHY)	Diesel	1997	4	85.00	51	TU1M (HDZ)	Petrol	1124	4	72.00	10
DW10TD (RHY)	Diesel	1997	4	85.00	73	TU1M (HDZ)	Petrol	1124	4	72.00	223
DW10TD (RHY)	Diesel	1997	4	85.00	84	TU1M (HDZ)	Petrol	1124	4	72.00	224
DW10UTD (RHV)	Diesel	1997	4	85.00	196	TU1M (HDZ)	Petrol	1124	4	72.00	25
DW10UTED4 (RHK)	Diesel	1997	4	85.00	182	TU1M (HDZ)	Petrol	1124	4	72.00	61
DW10UTED4 (RHK)	Diesel	1997	4	85.00	211	TU1M (HDZ)	Petrol	1124	4	72.00	8
DW12TED4 (4HX/4HW)	Diesel	2179	4	85.00	124	TU1M (HDZ)	Petrol	1124	4	72.00	87
DW12TED4 (4HX/4HW)	Diesel	2179	4	85.00	167	TU2.4	Petrol	1294	4	75.00	28
DW12TED4 (4HX/4HW)	Diesel	2179	4	85.00	184	TU2J2 (MFZ)	Petrol	1294	4	75.00	12
DW12UTED (4HY)	Diesel	2179	4	85.00	197	TU32	Petrol	1360	4	75.00	225
DW8 (WJZ)	Diesel	1868	4	82.20	205	TU3CP (KAY)	Petrol	1360	4	75.00	31
DW8 (WJZ)	Diesel	1868	4	82.20	229	TU3F2 (K1D)	Petrol	1360	4	75.00	31
DW8 (WJZ)	Diesel	1868	4	82.20	49	TU3F2 (K1D)	Petrol	1360	4	75.00	89
DW8 (WJZ)	Diesel	1868	4	82.20	67	TU3F2 (K2B)	Petrol	1360	4	75.00	89
DW8B (WJY)	Diesel	1868	4	82.20	205	TU3J2 (KFZ)	Petrol	1360	4	75.00	14
DW8B (WJY)	Diesel	1868	4	82.20	229	TU3JP (KFV)	Petrol	1360	4	75.00	186
DW8B (WJY)	Diesel	1868	4	82.20	67	TU3JP (KFW/K6D)	Petrol	1360	4	75.00	16
E1	Petrol	1118	4	74.00	86	TU3JP (KFW/K6D)	Petrol	1360	4	75.00	225
ES 9 J4	Petrol	2946	6	87.00	161	TU3JP (KFW/K6D)	Petrol	1360	4	75.00	43

		CC			9			CC			9
TU3JP (KFW/K6D)	Petrol	1360	4	75.00	62	XR5S (117)	Petrol	1472	4	78.00	57
TU3JP (KFW/K6D)	Petrol	1360	4	75.00	76	XU102C (R5A)	Petrol	1998	4	86.00	152
TU3JP (KFW/K6D)	Bi-Fuel	1360	4	75.00	226	XU10J2 (RFL)	Petrol	1998	4	86.00	195
TU3JP (KFX)	Petrol	1360	4	75.00	16	XU10J2 (RFU)	Petrol	1998	4	86.00	172
TU3JP (KFX)	Petrol	1360	4	75.00	225	XU10J2 (RFW)	Petrol	1998	4	86.00	195
TU3JP (KFX)	Petrol	1360	4	75.00	32	XU10J2 (RFX)	Petrol	1998	4	86.00	108
TU3JP (KFX)	Petrol	1360	4	75.00	43	XU10J2 (RFZ/R6A)	Petrol	1998	4	86.00	75
TU3JP (KFX)	Petrol	1360	4	75.00	62	XU10J2TE (RGX)	Petrol	1998	4	86.00	153
TU3M (KDY)	Petrol	1360	4	75.00	13	XU10J2TE (RGX)	Petrol	1998	4	86.00	121
TU3M (KDY)	Petrol	1360	4	75.00	31	XU10J2TE (RGX)	Petrol	1998	4	86.00	155
TU3M (KDY)	Petrol	1360	4	75.00	32	XU10J2TE (RGX)	Petrol	1998	4	86.00	177
TU3M (KDY)	Petrol	1360	4	75.00	89	XU10J2TE (RGY)	Petrol	1998	4	86.00	155
TU3M (KDZ)	Petrol	1360	4	75.00	31	XU10J4 (RFT)	Petrol	1998	4	86.00	109
TU3M (KDZ)	Petrol	1360	4	75.00	32	XU10J4 (RFT)	Petrol	1998	4	86.00	74
TU3M (KDZ)	Petrol	1360	4	75.00	89	XU10J4 (RFT/RFY)	Petrol	1998	4	86.00	109
TU3MC (KDX/KDY)	Petrol	1360	4	75.00	13	XU10J4 (RFT/RFY)	Petrol	1998	4	86.00	74
TU3MC (KDX/KDY)	Petrol	1360	4	75.00	62	XU10J4R (RFV/R6E)	Petrol	1998	4	86.00	117
TU3MC (KDX/KDY)	Petrol	1360	4	75.00	99	XU10J4R (RFV/R6E)	Petrol	1998	4	86.00	154
TU5J2 (NFW)	Petrol	1587	4	78.50	18	XU10J4R (RFV/R6E)	Petrol	1998	4	86.00	173
TU5J2 (NFW/NFY)	Petrol	1587	4	78.50	18	XU10J4R (RFV/R6E)	Petrol	1998	4	86.00	72
TU5J4 (NFX)	Petrol	1587	4	78.50	19	XU10J4RS (RFS)	Petrol	1998	4	86.00	72
TU5JP (NFT)	Petrol	1587	4	78.50	63	XU10J4TE (RGZ)	Petrol	1998	4	86.00	110
TU5JP (NFZ)	Petrol	1587	4	78.50	18	XU51C (B1A/B1C)	Petrol	1580	4	83.00	36
TU5JP (NFZ)	Petrol	1587	4	78.50	48	XU51C (B1A/B1C)	Petrol	1580	4	83.00	58
TU5JP (NFZ)	Petrol	1587	4	78.50	63	XU51C (B1A/B1C)	Petrol	1580	4	83.00	92
TU5JP4 (NFU/N6A)	Petrol	1587	4	78.50	189	XU51C (B1A/B1C/B1E)	Petrol	1580	4	83.00	100
TU5JP4 (NFU/N6A)	Petrol	1587	4	78.50	227	XU51C (B1A/B1C/B1E)	Petrol	1580	4	83.00	36
TU5JP4 (NFU/N6A)	Petrol	1587	4	78.50	46	XU51C (B1A/B1C/B1E)	Petrol	1580	4	83.00	92
TU5JP4 (NFU/N6A)	Petrol	1587	4	78.50	54	XU52C (B2A)	Petrol	1580	4	83.00	100
TU5JP4 (NFU/N6A)	Petrol	1587	4	78.50	79	XU52C (B2A)	Petrol	1580	4	83.00	92
TU9 (C1A/C1B)	Petrol	954	4	70.00	23	XU5CP (BAZ)	Petrol	1580	4	83.00	100
TU9M (CDY)	Petrol	954	4	70.00	6	XU5CP (BAZ)	Petrol	1580	4	83.00	36
TU9M (CDY)	Petrol	954	4	70.00	7	XU5CP (BAZ)	Petrol	1580	4	83.00	58
TU9M (CDZ)	Petrol	954	4	70.00	6	XU5CP (BAZ)	Petrol	1580	4	83.00	92
TU9M (CDZ)	Petrol	954	4	70.00	7	XU5J (180)	Petrol	1580	4	83.00	36
TUD3 (K9A/K9B/K9Y)	Diesel	1360	4	75.00	15	XU5J (180)	Petrol	1580	4	83.00	92
TUD5 (VJX)	Diesel	1527	4	77.00	17	XU5J (180A)	Petrol	1580	4	83.00	36
TUD5 (VJY/VJZ)	Diesel	1527	4	77.00	17	XU5J (B6B)	Petrol	1580	4	83.00	92
XC7P	Petrol	1618	4	84.00	218	XU5JP (BFZ)	Petrol	1580	4	83.00	101
XD2 (134)	Diesel	2304	4	94.00	138	XU5JP (BFZ)	Petrol	1580	4	83.00	111
XD2P / XD94	Diesel	2304	4	94.00	221	XU5M (BDZ)	Petrol	1580	4	83.00	100
XD2S (147)	Diesel	2304	4	94.00	145	XU5M (BDZ)	Petrol	1580	4	83.00	101
XD2S (147)	Diesel	2304	4	94.00	150	XU5M (BDZ)	Petrol	1580	4	83.00	92
XD3 (155)	Diesel	2498	4	94.00	146	XU5M2Z (BDY)	Petrol	1580	4	83.00	100
XD3P	Diesel	2498	4	94.00	222	XU5M2Z (BDY)	Petrol	1580	4	83.00	101
XD3T (152A)	Diesel	2498	4	94.00	147	XU5M2Z (BDY)	Petrol	1580	4	83.00	36
XD3T (152A)	Diesel	2498	4	94.00	151	XU5M2Z (BDY)	Petrol	1580	4	83.00	92
XD3TE (152B)	Diesel	2498	4	94.00	147	XU5M3Z (BDY)	Petrol	1580	4	83.00	100
XD88	Diesel	1948	4	88.00	134	XU5M3Z (BDY)	Petrol	1580	4	83.00	101
XD90	Diesel	2112	4	90.00	137	XU5M3Z (BDY)	Petrol	1580	4	83.00	36
XDPX90	Diesel	2112	4	90.00	220	XU5M3Z (BDY)	Petrol	1580	4	83.00	92
XL5 (118)	Petrol	1290	4	78.00	56	XU5S (171)	Petrol	1580	4	83.00	58
XM7	Petrol	1796	4	84.00	133	XU7JP (LFW)	Petrol	1761	4	83.00	170
XM7 (105)	Petrol	1796	4	84.00	139	XU7JP (LFW)	Petrol	1761	4	83.00	98
XM7A (105C)	Petrol	1796	4	84.00	139	XU7JP (LFZ)	Petrol	1761	4	83.00	102
XM7T (169B)	Petrol	1796	4	84.00	212	XU7JP (LFZ)	Petrol	1761	4	83.00	64
XN1	Petrol	1971	4	88.00	136	XU7JP (LFZ)	Petrol	1761	4	83.00	98
XN1 (106)	Petrol	1971	4	88.00	136	XU7JP4 (LFY)	Petrol	1761	4	83.00	113
XN1 (106)	Petrol	1971	4	88.00	140	XU7JP4 (LFY)	Petrol	1761	4	83.00	65
XN1A (106E)	Petrol	1971	4	88.00	140	XU92C	Petrol	1905	4	83.00	59
XN1P	Petrol	1971	4	88.00	219	XU92C (D2A)	Petrol	1905	4	83.00	40
XN1T (170)	Petrol	1971	4	88.00	214	XU92C (D2A/D2C/D2D)	Petrol	1905	4	83.00	104
XN1T (170B)	Petrol	1971	4	88.00	214	XU9J1 (DFZ)	Petrol	1905	4	83.00	104
XN1T (170D)	Petrol	1971	4	88.00	214	XU9J1 (DFZ)	Petrol	1905	4	83.00	40
XN2 (107)	Petrol	1971	4	88.00	135	XU9J1 (DFZ)	Petrol	1905	4	83.00	59
XN6	Petrol	1971	4	88.00	141	XU9J1 (DFZ)	Petrol	1905	4	83.00	95
XN6	Petrol	1971	4	88.00	149	XU9J4 (D6C/DFW)	Petrol	1905	4	83.00	106
XR5 (142)	Petrol	1472	4	78.00	57	XU9J4 (D6C/DFW)	Petrol	1905	4	83.00	97
XR5A (142)	Petrol	1472	4	78.00	57	XU9J4 (DFW)	Petrol	1905	4	83.00	106



CC



9



CC



9

XU9J4 (DFW)	Petrol	1905	4	83.00	97
XU9JA (D6B)	Petrol	1905	4	83.00	40
XU9JA (D6B)	Petrol	1905	4	83.00	95
XU9JAZ (DKZ)	Petrol	1905	4	83.00	104
XU9JAZ (DKZ)	Petrol	1905	4	83.00	41
XU9JAZ (DKZ)	Petrol	1905	4	83.00	95
XU9M (DDZ)	Petrol	1905	4	83.00	104
XU9M (DDZ)	Petrol	1905	4	83.00	95
XU9S (D2B)	Petrol	1905	4	83.00	95
XUD11A (P9A/PJZ)	Diesel	2138	4	86.00	156
XUD11ATE (PHZ/P8A/P8B)	Diesel	2088	4	85.00	157
XUD11BTE (P8C)	Diesel	2088	4	85.00	122
XUD11BTE (P8C)	Diesel	2088	4	85.00	158
XUD11BTE (P8C)	Diesel	2088	4	85.00	178
XUD7 (161A)	Diesel	1769	4	80.00	37
XUD7 (161A)	Diesel	1769	4	80.00	93
XUD7 (A9A)	Diesel	1769	4	80.00	228
XUD7 (A9A)	Diesel	1769	4	80.00	66
XUD7TE (A8A)	Diesel	1769	4	80.00	103
XUD7TE (A8B)	Diesel	1769	4	80.00	38
XUD7TE (A8B)	Diesel	1769	4	80.00	94
XUD7TE (AJZ)	Diesel	1769	4	80.00	103
XUD9 (162)	Diesel	1905	4	83.00	60
XUD9 (162)	Diesel	1905	4	83.00	96
XUD9 (D9A)	Diesel	1905	4	83.00	60
XUD9 (D9A)	Diesel	1905	4	83.00	96
XUD9 (DJZ/D9A/162)	Diesel	1905	4	83.00	105
XUD9 (DJZ/D9A/162)	Diesel	1905	4	83.00	39
XUD9 (DJZ/D9A/162)	Diesel	1905	4	83.00	68
XUD9 (DJZ/D9A/162)	Diesel	1905	4	83.00	96
XUD9A (D9B)	Diesel	1905	4	83.00	204
XUD9A (D9B/DJY)	Diesel	1905	4	83.00	192
XUD9A (D9B/DJY/DJZ)	Diesel	1905	4	83.00	105
XUD9A (D9B/DJY/DJZ)	Diesel	1905	4	83.00	213
XUD9A (DJY/D9B)	Diesel	1905	4	83.00	105
XUD9A (DJY/D9B)	Diesel	1905	4	83.00	192
XUD9A (DJY/D9B)	Diesel	1905	4	83.00	230
XUD9A (DJY/D9B)	Diesel	1905	4	83.00	68
XUD9BSD (DHV/DHW)	Diesel	1905	4	83.00	69
XUD9SD (DHW)	Diesel	1905	4	83.00	114
XUD9TE	Diesel	1905	4	83.00	193
XUD9TE (D8B)	Diesel	1905	4	83.00	206
XUD9TE (DHX)	Diesel	1905	4	83.00	115
XUD9TE (DHX)	Diesel	1905	4	83.00	171
XUD9TE (DHX)	Diesel	1905	4	83.00	206
XUD9TE (DHX/DHY/D8A)	Diesel	1905	4	83.00	107
XUD9TE (DHX/DHY/D8A)	Diesel	1905	4	83.00	115
XUD9TE (DHX/DHY/D8A)	Diesel	1905	4	83.00	193
XUD9TE (DHX/DHY/D8A)	Diesel	1905	4	83.00	70
XUD9UTF (D8C/DHX)	Diesel	1905	4	83.00	194
XV8 (108C)	Petrol	954	4	70.00	1
XV8 (108C)	Petrol	954	4	70.00	22
XW3S	Petrol	1124	4	72.00	3
XW7 (109F)	Petrol	1124	4	72.00	2
XW7 (109F)	Petrol	1124	4	72.00	24
XW7 (109N)	Petrol	1124	4	72.00	24
XY6B (150)	Petrol	1360	4	75.00	29
XY6B (150)	Petrol	1360	4	75.00	30
XY6B (150)	Petrol	1360	4	75.00	5
XY7 (150D)	Petrol	1360	4	75.00	29
XY7 (150D)	Petrol	1360	4	75.00	30
XY7 (150G)	Petrol	1360	4	75.00	29
XY7 (150G)	Petrol	1360	4	75.00	30
XY8 (150B)	Petrol	1360	4	75.00	29
XY8 (150H)	Petrol	1360	4	75.00	29
XY8 (150H)	Petrol	1360	4	75.00	30
XZ5 (129)	Petrol	1219	4	75.00	4
Y2	Petrol	1442	4	76.70	91
ZDJ (851)	Petrol	2165	4	88.00	143

ZDJL (851B)	Petrol	2165	4	88.00	143
ZDJL (851X)	Petrol	2165	4	88.00	143
ZEJ (829)	Petrol	1995	4	88.00	142
ZN3J (154X)	Petrol	2849	6	91.00	148
ZPJ (UFZ)	Petrol	2963	6	93.00	160
ZPJ4 (UKZ)	Petrol	2963	6	93.00	160

Type Mines OU C.N.I.T.*	Encadré N°	Type Mines OU C.N.I.T.*	Encadré N°	Type Mines OU C.N.I.T.*	Encadré N°	Type Mines OU C.N.I.T.*	Encadré N°
104		1AVJY2	17	1CVJY2	17	MPE1002BY061	8
104A11	2	1AVJYE	17	1CVJYE	17	MPE1101B0407	13
104A17	2	1AVJYF	17	1CVJYF	17	MPE1101BE069	13
104A21	4	1AVJZ2	17	1CVJZ2	17	MPE1101BG071	13
104A27	4	1AVJZD	17	1CVJZD	17	MPE1101BK075	13
104A31	5	1AVJZE	17	1CVJZE	17	MPE1101BM077	13
104A37	5	1AVJZF	17	1CVJZF	17	MPE1101BP759	16
104A41	1	1CC1A1	6	1SC1A1	6	MPE1101BQ760	16
104C01	1	1CC1A2	6	1SCDY1	6	MPE1101BW572	13
104C07	1	1CCDY1	6	1SCDZ2	6	MPE1101BX573	13
104C11	2	1CCDY2	6	1SCDZD	7	MPE1102B0574	13
104C12	3	1CCDYE	7	1SCDZE	7	MPE1102BE067	13
104C17	2	1CCDZ1	6	1SH1A1	8	MPE1102BL074	13
104C31	5	1CCDZ2	6	1SH1A2	8	MPE1102BT761	16
104C37	5	1CCDZD	7	1SH3A1	11	MPE1201B8089	18
104S01	1	1CCDZE	7	1SHDZ2	8	MPE1301BK091	18
104S11	2	1CCDZW	7	1SHDZD	10	MPE1401BJ661	19
106		1CH1A1	8	1SHDZE	10	MPE1401BU382	19
1AC1A1	6	1CH1A2	8	1SHFXF	10	MPE1401BV092	19
1ACDY1	6	1CH3A1	8	1SK9B1	15	MPE3101BR076	16
1ACDY2	6	1CH3A2	11	1SK9B2	15	MPE3102BQ073	16
1ACDYE	7	1CHDY1	8	1SK9B9	15	MPE3201BC087	18
1ACDZ1	6	1CHDY2	8	1SK9Y2	15	MPE5001B9414	17
1ACDZ2	6	1CHDYE	11	1SVJXF	17	MPE5001BN101	17
1ACDZD	7	1CHDZ1	8	1SVJY2	17	MPE5001BP102	17
1ACDZE	7	1CHDZ2	8	1SVJYE	17	MPE5001BP103	17
1ACDZW	7	1CHDZ8	8	1SVJZD	17	MPE5001BR662	17
1AH1A1	8	1CHDZD	10	1SVJZE	17	MPE5002BC415	17
1AH1A2	8	1CHDZE	10	MPE000AB0050	17	MPE5002BL097	17
1AH3A1	8	1CHDZE/GPL	10	MPE000AB2052	17	MPE5002BM098	17
1AH3A2	8	1CHFXF	10	MPE000AB2210	16	MPE5002BN099	17
1AH3A8	11	1CK2D2	13	MPE000AB3211	16	MPE5002BP100	17
1AHDY2	8	1CK5A2	16	MPE000AB5213	13	MPE5002BU663	17
1AHDYE	11	1CK6B2	14	MPE000AB6020	7	MPEZ001BF063	10
1AHDZ1	8	1CK9B1	15	MPE000AB6214	13	MPEZ002BF061	10
1AHDZ2	8	1CK9B2	15	MPE000AB7215	13	VPE000AB5082	17
1AHDZ8	8	1CK9Y2	15	MPE000AB8022	6	VPE1001B1057	7
1AHDZD	10	1CKDX2	13	MPE000ABC026	8	VPE1001B7063	8
1AHDZE	10	1CKDX8	13	MPE000ABD027	8	VPE1001BS569	8
1AHDZE/GPL	10	1CKDY2	13	MPE000ABE028	8	VPE1001BT570	8
1AHFXF	10	1CKFWF	16	MPE000ABG066	18	VPE5001BX102	17
1AK2D2	13	1CKFWU	16	MPE000ABJ032	13	VPE5001BZ104	17
1AK5A2	16	1CKFXD	16	MPE000ABJ068	18	107	
1AK9B1	15	1CKFXE	16	MPE000ABK034	13	MPE1011SG160	20
1AK9B2	15	1CKFXE/IF	16	MPE000ABM036	13	MPE1011SH355	20
1AK9B9	15	1CKFXL	16	MPE000ABM072	18	MPE1011SX784	20
1AK9Y2	15	1CKFXS	16	MPE000ABP074	18	MPE1012S1786	20
1AKDX8	13	1CKFXT	16	MPE000ABP075	17	MPE1012SK162	20
1AKDY2	13	1CKFXT/IF	16	MPE000ABS078	17	MPE1012SL357	20
1AKFWF	16	1CKFXU/IFL4	16	MPE000ABS721	13	MPE3011SP356	20
1AKFXE	16	1CKFZ2	14	MPE000ABW046	18	MPE3012SS358	20
1AKFXE/IF	16	1CMFZ2	12	MPE000ABW082	17	MPE5011SK213	21
1AKFXL	16	1CNFWE	18	MPE000ABX047	19	MPE5011SS354	21
1AKFXS	16	1CNFX2	19	MPE1001BJ569	6	MPE5012SN214	21
1AKFXT	16	1CNFXE	19	MPE1001BK570	8	PM8HTC	21
1AKFXT/IF	16	1CNFXE/D3	19	MPE1001BP053	6	PMCFCAC	20
1AKFXU/IFL4	16	1CNFXF	19	MPE1001BR056	6	PN8HTC	21
1ANFZ2	18	1CNFY2	18	MPE1001BS057	7	PNCFCAC	20
1ANFZ4	18	1CNFZ2	18	MPE1001BX062	8	UPE1011SG160	20
1ANFZE	18	1CNFZ4	18	MPE1001BY063	8	UPE1012SK162	20
1ANFZL	18	1CNFZE	18	MPE1002BK568	7	UPE5011SK213	21
1ANFZT	18	1CNFZL	18	MPE1002BN571	8	UPE5012SN214	21
1AVJUF	17	1CNFZT	18	MPE1002BR054	7		
1AVJXF	17	1CVJUF	17	MPE1002BS055	7		
		1CVJXF	17	MPE1002BX060	8		

* C.N.I.T. = Code National d'Identification du Type (code D2.1 sur nouvelles cartes grises)

Type Mines OU C.N.I.T.*	Encadré N°	Type Mines OU C.N.I.T.*	Encadré N°	Type Mines OU C.N.I.T.*	Encadré N°	Type Mines OU C.N.I.T.*	Encadré N°
205		20CKA2	31	741S17	24	2CHFXF	42
20AA91	37	20CKD2	29	741S41	30	2CHFYE	42
20AA92	37	20CKD21	29	741S47	30	2CHFZ2	42
20AB14	36	20CL11	23	741S90	37	2CHFZE	42
20ABD2	36	20CL12	24	741S98	37	2CHFZW	42
20ABD21	36	20CM11	25	742A47	27	2CK6C2	43
20ABD4	36	20CM22	28	742A52	33	2CKFUF	44
20ABD41	36	20CN11	23	742A57	33	2CKFWA	43
20AC11	23	20CN12	23	742C47	27	2CKFWB	43
20AC12	23	20DBA2	36	742C67	36	2CKFWB/IF	43
20AC27	36	20DBD2	36	MPE000AJF312	37	2CKFWF	43
20ACD1	23	20DDF2	40	MPE000AJG313	37	2CKFWR	43
20ACD2	23	20DH12	25	MPE000AJH314	32	2CKFXE	43
20ADF4	40	20DHD2	25	MPE000AJJ315	29	2CKFXP	43
20ADJ2	39	20DK12	31	MPE1101JQ231	29	2CKFXW	43
20AF12	26	20DK22	31	MPE1102JQ229	31	2CNFUF	46
20AH11	25	20DK221	29	MPE1401BV092	36	2CNFUR	46
20AH12	25	20DKA2	31	MPE5001JR230	37	2CNFUU	46
20AH31	25	20DKD2	31	MPE5002JR228	37	2CNFZE	48
20AH32	25	20DT12	29	VPE000AJP313	37	2CNFZP	48
20AHD2	25	20SA82	38	VPE000AJR315	31	2CNFZW	48
20AK11	31	20SA91	37	VPE5001J0230	37	2CRFKA	50
20AK12	31	20SA92	37			2CRFNF	50
20AK121	31	20SC11	23	206		2CRFRE	50
20AK31	31	20SDJ2	39	2A8HXF	45	2CRFRE/IF	50
20AK32	31	20SH11	25	2A8HZA	45	2CRFRE/IFWRC	50
20AKA2	31	20SH12	25	2A8HZF	45	2CRFRE/WRC	50
20AKD2	32	20SHD2	25	2AHFXA	42	2CRHYE	51
20AKD21	32	20SK11	31	2AHFXA/IF	42	2CRHYF	51
20AKD22	32	20SK12	31	2AHFXF	42	2CRHYU	51
20AKH1	31	20SK31	31	2AHFYE	42	2CRHYX	51
20AL11	24	20SL11	29	2AHFZ2	42	2CWJYF	49
20AL12	24	20SL12	29	2AHFZE	42	2CWJZT	49
20AN11	23	20TA92	37	2AHFZW	42	2CWJZW	49
20AN12	23	741A01	22	2AK6C2	43	2D9HZA	47
20CA91	37	741A07	22	2AK6C8	43	2DNFUA	46
20CA92	37	741A11	24	2AKFUA	44	2DNFUB	46
20CB14	36	741A17	24	2AKFUF	44	2DNFUF	46
20CB141	36	741A28	36	2AKFWA	43	2DNFUR	46
20CB62	36	741A37	30	2AKFWB	43	2DRFNF	50
20CB622	36	741A41	30	2AKFWF	43	2E8HXF	45
20CBD2	36	741A47	30	2AKFWR	43	2E8HZA	45
20CBD21	36	741A57	30	2AKFX4	43	2E8HZF	45
20CBD4	36	741A661	36	2AKFXE	43	2EHFXF	42
20CBD41	36	741A90	37	2AKFXF	43	2EKFUF	44
20CC11	23	741A98	37	2AKFXP	43	2EKFWA	43
20CC12	23	741B17	24	2AKFXW	43	2EKFWA/IFL5	43
20CCD1	23	741B57	29	2ANFUF	46	2EKFWF	43
20CCD2	23	741B66	36	2ANFUR	46	2ERFNF	50
20CD62	40	741B86	40	2ANFUU	46	2ERHYF	51
20CDF2	40	741C01	22	2ANFZE	48	2H9HYA	47
20CDF2A	40	741C07	22	2ANFZP	48	2H9HZA	47
20CDF4	40	741C11	24	2ANFZW	48	2HKFUA	44
20CDJ2	39	741C17	24	2ARHYE	51	2HKFUF	44
20CDK2	41	741C27	36	2ARHYF	51	2HNFUA	46
20CDK4	41	741C28	36	2ARHYU	51	2HNFUB	46
20CH11	25	741C37	29	2AWJYF	49	2HNFUF	46
20CH12	25	741C47	29	2AWJYU	49	2HNFUR	46
20CH31	25	741C57	30	2AWJZT	49	2HRHYF	51
20CHD2	25	741C66	36	2AWJZW	49	2J9HYA	47
20CJ22	36	741C661	36	2C8HXF	45	2J9HZA	47
20CK12	31	741C86	40	2C8HZA	45	2JNFUA	46
20CK121	31	741C90	37	2C8HZF	45	2JNFUB	46
20CK32	31	741C98	37	2CHFXA	42	2JNFUF	46
		741S11	24	2CHFXA/IF	42	2JNFUR	46

* C.N.I.T. = Code National d'Identification du Type (code D2.1 sur nouvelles cartes grises)

Type Mines OU C.N.I.T.*	Encadré N°	Type Mines OU C.N.I.T.*	Encadré N°	Type Mines OU C.N.I.T.*	Encadré N°	Type Mines OU C.N.I.T.*	Encadré N°
2JRHYF	51	MPE1204KP988	44	MPE5102K4363	49	MPE5312TY327	55
2K9HYA	47	MPE1204KR991	44	MPE5102KA660	49	MPE5312TZ328	55
2K9HZA	47	MPE1204KT993	44	MPE5102KC565	49	UPE1211TE270	52
2KKFUA	44	MPE1301KU699	46	MPE5102KJ438	49	UPE1212TL275	52
2KKFUF	44	MPE1301KZ643	46	MPE5102KK695	49	UPE1311TP271	54
2KNFUA	46	MPE1302K2644	46	MPE5102KY321	49	UPE1312TW276	54
2KNFUB	46	MPE1304KW889	46	MPE5201K1546	51	UPE5011T3267	53
2KNFUF	46	MPE1305K9645	46	MPE5201K9748	51	UPE5011TA626	53
2KNFUR	46	MPE1311K5127	46	MPE5201KG658	51	UPE5011TR316	53
2KRHYF	51	MPE1311K6128	46	MPE5201KZ411	51	UPE5012TA272	53
2S8HXF	45	MPE1312K3123	46	MPE5202K0410	51	UPE5211TC317	55
2S8HZA	45	MPE1312K4124	46	MPE5202K2545	51	UPE5211TP268	55
2S8HZF	45	MPE1312K5064	46	MPE5202KH657	51	UPE5211TV627	55
2SHFXU	42	MPE1312K9129	46	MPE5204K0891	51	UPE5212TV273	55
2SHFZW	42	MPE1312KA130	46	MPE5204K1892	51	UPE5311T9304	55
2SRHYE	51	MPE1314KF131	46	MPE5212K4061	51	UPE5311TZ269	55
2SWJYU	49	MPE1314KG132	46	MPE5311KR295	47	UPE5312T6274	55
2SWJZW	49	MPE1315KJ133	46	MPE5311KS077	47	UPE5312TC305	55
2TWJYU	49	MPE1315KK134	46	MPE5312KU296	47	WA8HZC	53
2TWJZW	49	MPE1501KJ412	50	MPE5312KV078	47	WA9HVL	55
MPE000AK2431	48	MPE1501KJ413	50	MPE5314K0079	47	WA9HXC	55
MPE000AK4433	49	MPE1501KM646	50	MPE5314KZ297	47	WA9HYC	55
MPE000AK5434	49	MPE1501KN647	50	MPE5315KB149	47	WA9HZC	55
MPE000AK6435	43	MPE1501KT459	50	UPE5014KY265	45	WAKFUC	52
MPE000AK7436	43	MPE1501KU460	50	VPE1001KF317	42	WANFUC	54
MPE000AKW425	42	MPE1504KF888	50	VPE5101K6322	49	WANFUF	54
MPE000AKX426	42	MPE1505KW648	50	VPE5101KJ564	49	WC8HZC	53
MPE1001K6317	42	MPE1515K3266	50			WC9HXC	55
MPE1001K8743	42	MPE1701KX928	50	207		WC9HYC	55
MPE1001KD324	42	MPE1711KB262	50	M10PGTVP000F218	52	WC9HZC	55
MPE1001KF362	42	MPE3101K1393	43	MPE1211T3320	52	WCKFUC	52
MPE1001KR593	42	MPE3101KD768	43	MPE1211TE270	52	WCNFUC	54
MPE1002K6315	42	MPE3101KN706	43	MPE1212TE329	52		
MPE1002KB744	42	MPE3102K2392	43	MPE1212TL275	52	305	
MPE1002KG361	42	MPE3102KE767	43	MPE1212TX736	52	5810	56
MPE1002KU594	42	MPE3102KP705	43	MPE1311TG323	54	581A01	56
MPE1004KY885	42	MPE3201KF494	48	MPE1311TP271	54	581A11	57
MPE1101KD641	43	MPE3202KG493	48	MPE1312TR332	54	581A12	57
MPE1101KG741	43	MPE3301K1700	46	MPE1312TW276	54	581A21	57
MPE1101KJ222	43	MPE3301KX696	46	MPE5011T3267	53	581A21/A	57
MPE1101KU367	43	MPE3302K0697	46	MPE5011TR316	53	581AC1	57
MPE1101KV368	43	MPE3304K3890	46	MPE5012T2325	53	581D01	56
MPE1102KG642	43	MPE3305K7698	46	MPE5012TA272	53	581D11	57
MPE1102KJ221	43	MPE3311K4253	46	MPE5012TJ730	53	581E11	57
MPE1102KJ742	43	MPE3312K3250	46	MPE5211T4478	55	581E11/Z	57
MPE1102KU365	43	MPE3312K7254	46	MPE5211TC317	55	581E14	57
MPE1102KV366	43	MPE3312KC065	46	MPE5211TP268	55	581E27	58
MPE1104K9886	43	MPE3314KC255	46	MPE5211TR429	55	581E40	60
MPE1104KA887	43	MPE3315KB252	46	MPE5212T8480	55	581E48	60
MPE1111K9248	43	MPE5001KA794	45	MPE5212TN326	55	581E54	58
MPE1112KA247	43	MPE5002JR228	49	MPE5212TP655	55	581E56	58
MPE1114KG249	43	MPE5002KB793	45	MPE5212TV273	55	581E76	59
MPE1201K7370	48	MPE5004KJ893	45	MPE5212TX433	55	581E84	59
MPE1201K9566	48	MPE5011K3107	45	MPE5311T3661	55	581E86	59
MPE1201KE984	44	MPE5011KH387	45	MPE5311T9304	55	581M01	56
MPE1201KH987	44	MPE5011KR264	45	MPE5311TB342	55	581M11	57
MPE1201KJ989	44	MPE5012K4106	45	MPE5311TF479	55	581M11/Z	57
MPE1201KM992	44	MPE5012KJ386	45	MPE5311TN318	55	581M27	58
MPE1201KT320	48	MPE5012KS263	45	MPE5311TP319	55	581M40	60
MPE1202K8369	48	MPE5014KA108	45	MPE5311TV653	55	581M48	60
MPE1202KC567	48	MPE5014KY265	45	MPE5311TY717	55	581M54	58
MPE1202KH985	44	MPE5101K9564	49	MPE5311TZ269	55	581M56	58
MPE1202KM990	44	MPE5101KF437	49	MPE5312T0656	55	581M74	59
MPE1202KU319	48	MPE5101KH694	49	MPE5312T6274	55	581M76	59
MPE1204KM986	44	MPE5101KX322	49	MPE5312TC305	55	581M84	59
				MPE5312TJ481	55	581M86	59

* C.N.I.T. = Code National d'Identification du Type (code D2.1 sur nouvelles cartes grises)

Type Mines OU C.N.I.T.*	Encadré N°	Type Mines OU C.N.I.T.*	Encadré N°	Type Mines OU C.N.I.T.*	Encadré N°	Type Mines OU C.N.I.T.*	Encadré N°
306		7BDHVE	69	7CK5A2	62	7EKFXW	62
7AA9A2	66	7BDHY2	70	7CKDX2	62	7EL6A2	64
7AA9AT	66	7BDHYE	70	7CKDX9	62	7EL6A4	64
7AD8A2	70	7BDJY2	68	7CKFWF	62	7ELFYE	65
7AD8AD	70	7BDJYE	68	7CKFXE	62	7ELFYE/GPL	65
7AD9B2	68	7BDJYT	68	7CKFXT	62	7ELFYF	65
7AD9BD	68	7BK2D2	62	7CKFXW	62	7ELFYF/D4	65
7ADHVE	69	7BK2D9	62	7CL6A2	64	7ELFYT	65
7ADHY2	70	7BK5A2	62	7CLFYE	65	7ELFYT/GPL	65
7ADHYE	70	7BKDX2	62	7CLFYF	65	7ELFYW	65
7ADJY2	68	7BKDX9	62	7CLFZ2	64	7ELFZP	64
7ADJYE	68	7BKFWF	62	7CLFZ4	64	7ENFTF	63
7ADJYE	68	7BKFX2	62	7CLFZ8	64	7ENFTR	63
7ADJYT	68	7BKFXE	62	7CLFZ9	64	7ENFZE	63
7ADJZ2	68	7BKFXT	62	7CLFZP	64	7ENFZW	63
7AHDY2	61	7BKFXT/GPL	62	7CNFZ2	63	7ERFVE	72
7AHDZ2	61	7BKFXT/IF	62	7CNFZ9	63	7ERFVP	72
7AK2D2	62	7BKFXW	62	7CNFZE	63	7ERFVW	72
7AK5A2	62	7BL6A2	64	7CR6D2	75	7ERHYE	73
7AKDX2	62	7BL6A4	64	7CR6E2	72	7ERHYF	73
7AKDX9	62	7BL6A9	64	7CRFS2	72	7EWJYF	67
7AKFWF	62	7BLFYE	65	7CRFSH	72	7EWJZT	67
7AKFXE	62	7BLFYE/GPL	65	7CRFSW	72	7HRHYE	73
7AKFXT	62	7BLFYF	65	7CRFT2	74	7HRHYF	73
7AKFXT/GPL	62	7BLFYF/D4	65	7CRFV2	72	7JRHYP	73
7AKFXW	62	7BLFYT	65	7CRFVE	72	7SA9A2	66
7AL6A2	64	7BLFYT/GPL	65	7CRFVP	72	7SA9AE	66
7AL6A4	64	7BLFYW	65	7CRFX2	75	7SD9B2	68
7AL6A9	64	7BLFZ2	64	7CRFX4	75	7SDJY2	68
7ALFYE	65	7BLFZ4	64	7CRFX8	75	7SDJYE	68
7ALFYE/GPL	65	7BLFZ8	64	7CRFY2	74	7SDJYT	68
7ALFYF	65	7BLFZ9	64	7CRHYE	73	7SDJZ2	68
7ALFYF/D4	65	7BLFZP	64	7CWJYF	67	7SHDY2	61
7ALFYT	65	7BLFZW	64	7CWJZT	67	7SHDZ2	61
7ALFYT/GPL	65	7BNFTF	63	7DL6A2	64	7SK2D2	62
7ALFYW	65	7BNFTR	63	7DL6A4	64	7SKDX2	62
7ALFZ2	64	7BNFZ2	63	7DLFYE	65	7SKFXE	62
7ALFZ4	64	7BNFZ8	63	7DLFYF	65	7SWJYF	67
7ALFZ8	64	7BNFZ9	63	7DLFYT	65	MPE000AD0145	62
7ALFZ9	64	7BNFZE	63	7DLFZ2	64	MPE000AD0242	72
7ALFZP	64	7BNFZW	63	7DLFZ4	64	MPE000AD1146	62
7ANFTF	63	7BRFVE	72	7DLFZ8	64	MPE000AD2147	65
7ANFTR	63	7BRFVP	72	7DLFZP	64	MPE000AD4149	64
7ANFZ2	63	7BRFVW	72	7DNFTF	63	MPE000AD8153	64
7ANFZ9	63	7BRFX2	75	7DNFTR	63	MPE000AD9154	65
7ANFZE	63	7BRFX4	75	7DNFZ2	63	MPE000ADA155	65
7ANFZW	63	7BRFX8	75	7DNFZE	63	MPE000ADC157	64
7AR6D2	75	7BRHYE	73	7DNFZE/IF	63	MPE000ADD158	64
7ARFT2	74	7BRHYF	73	7DR6D2	75	MPE000ADF160	64
7ARFV2	72	7BWJYF	67	7DR6E2	72	MPE000ADG161	64
7ARFVE	72	7BWJZT	67	7DRFVE	72	MPE000ADH162	63
7ARFVP	72	7CA9A2	66	7DRFVP	72	MPE000ADJ128	70
7ARFVW	72	7CA9AT	66	7DRFVW	72	MPE000ADJ163	63
7ARFX2	75	7CD8A2	70	7DRFX2	75	MPE000ADJ164	63
7ARFX4	75	7CD9B2	68	7DRFX4	75	MPE000ADK165	63
7ARFX8	75	7CDHVE	69	7ED9BD	68	MPE000ADL130	70
7ARFY2	74	7CDHY2	70	7EDHVE	69	MPE000ADL166	63
7ARHYE	73	7CDHYE	70	7EDHYE	70	MPE000ADM167	72
7ARHYF	73	7CDJY2	68	7EDJYE	68	MPE000ADN168	72
7AWJYF	67	7CDJYE	68	7EDJYT	68	MPE000ADN423	70
7AWJZT	67	7CDJYT	68	7EK5A2	62	MPE000ADP170	72
7BD8A2	70	7CDJZ2	68	7EKFWF	62	MPE000ADP424	70
7BD8AD	70	7CHDY2	61	7EKFXE	62	MPE000ADQ171	72
7BD9B2	68	7CHDZ2	61	7EKFXT	62	MPE000ADQ717	72
7BD9BD	68	7CK2D2	62	7EKFXT/GPL	62	MPE000ADR136	68

* C.N.I.T. = Code National d'Identification du Type (code D2.1 sur nouvelles cartes grises)

Type Mines OU C.N.I.T.*	Encadré N°	Type Mines OU C.N.I.T.*	Encadré N°	Type Mines OU C.N.I.T.*	Encadré N°	Type Mines OU C.N.I.T.*	Encadré N°	
MPE000ADS137	68	MPE3302DB618	63	307		3CRHRJ	83	
MPE000ADS173	72	MPE3302DC619	63				3CRHSB	83
MPE000ADT138	68	MPE3304DD167	64		3A8HZB	78	3CRHY	84
MPE000ADT174	72	MPE3304DJ622	63		3A8HZB/T	78	3CRHYB	84
MPE000ADU139	62	MPE3305DE166	64		3A9HXC	80	3CRHYM	84
MPE000ADV140	62	MPE3305DK621	63		3A9HXC/T	80	3E8HZB	78
MPE000ADV176	72	MPE3501D2178	72		3A9HYB	80	3E9HXC	80
MPE000ADW177	72	MPE3502D0174	72		3A9HYB/T	80	3E9HYB	80
MPE000ADX142	62	MPE3502D2176	72		3A9HZB	80	3E9HYC	80
MPE000ADZ144	62	MPE3504DC182	72		3A9HZB/T	80	3E9HZB	80
MPE1101D0150	62	MPE3504MJ883	72		3A9HZC	80	3E9HZC	80
MPE1101DQ625	62	MPE3504MS929	72		3AK6DY	76	3EKFUB	77
MPE1101DT373	62	MPE3505DC180	72		3AKFUB	77	3EKFUC	77
MPE1101DZ149	62	MPE5001DT141	68		3AKFUC	77	3ENFUB	79
MPE1102D0148	62	MPE5001DU142	68		3AKFUC/T	77	3ENFUC	79
MPE1102DQ623	62	MPE5002DR137	68		3AKFWB	76	3ENFUE	79
MPE1102DR624	62	MPE5002DS138	68		3AKFWB/T	76	3ENFUF	79
MPE1102DT371	62	MPE5002DT139	68		3AN6A5	79	3ERFJC	82
MPE1102DU372	62	MPE5002DU140	67		3ANFUB	79	3ERFJF	82
MPE1102DX145	62	MPE5004D1143	68		3ANFUE	79	3ERFNB	81
MPE1102DY146	62	MPE5004D2144	67		3ANFUF	79	3ERFNC	81
MPE1102DZ147	62	MPE5101D7727	67		3ANFUL	79	3ERFNE	81
MPE1104D0374	62	MPE5101DW389	67		3ARFJC	82	3ERFNF	81
MPE1104D7151	62	MPE5101DW558	67		3ARFJF	82	3ERHRH	83
MPE1104D8152	62	MPE5102D7725	67		3ARFKC	82	3ERHSB	83
MPE1104DD387	62	MPE5102D8726	67		3ARFN8	81	3ERHY	84
MPE1104DX626	62	MPE5102DW556	67		3ARFNB	81	3ERHYB	84
MPE1201D9379	63	MPE5102DX388	67		3ARFNE	81	3G9HXC	80
MPE1201DU170	63	MPE5102DX557	67	3ARHRH	83	3G9HYB	80	
MPE1202D9377	63	MPE5102DZ390	67	3ARHRJ	83	3GKFUC	77	
MPE1202DA378	63	MPE5104D3559	67	3ARHSB	83	3H9HYB	80	
MPE1202DU168	63	MPE5104D4391	67	3ARHY	84	3H9HYC	80	
MPE1202DV169	63	MPE5104DE728	67	3ARHYB	84	3H9HZB	80	
MPE1204D2172	63	MPE5201D2712	73	3ARHYB/T	84	3HNFUB	79	
MPE1204DH381	63	MPE5201D3458	73	3ARHYM	84	3HNFUC	79	
MPE1205D3171	63	MPE5201D7135	70	3BNFU	79	3HNFUE	79	
MPE1205DJ380	63	MPE5201DL476	73	3BNFUC	79	3HNFUF	79	
MPE1302D0613	63	MPE5201DP443	73	3BRFJC	82	3HNFUN	79	
MPE1302D1614	63	MPE5202D0708	73	3BRFJF	82	3HRFJC	82	
MPE1304D8617	63	MPE5202D3711	73	3BRFKC	81	3HRFJF	82	
MPE1305D9616	63	MPE5202D7133	70	3BRFNC	81	3HRFNB	81	
MPE1401D1157	65	MPE5202D8134	70	3BRFNF	81	3HRFNC	81	
MPE1401DU671	65	MPE5202DJ472	73	3BRHRH	83	3HRFNE	81	
MPE1401DY542	65	MPE5202DK473	73	3C8HZB	78	3HRFNF	81	
MPE1402D0154	65	MPE5202DP441	73	3C8HZM	78	3HRHRH	83	
MPE1402D1155	65	MPE5202DP442	73	3C9HXC	80	3HRHRJ	83	
MPE1402D2156	65	MPE5202DP477	73	3C9HYB	80	3HRHSB	83	
MPE1402DU669	65	MPE5202DZ707	73	3C9HYC	80	3HRHY	84	
MPE1402DV670	65	MPE5204D6710	73	3C9HZB	80	3HRHYB	84	
MPE1402DZ153	65	MPE5204DE136	70	3C9HZC	80	MPE1101MT752	76	
MPE1404D2673	65	MPE5204DQ475	73	3CKFUB	77	MPE1102MW753	76	
MPE1404DB161	65	MPE5204DV444	73	3CKFUC	77	MPE1201MA978	77	
MPE1404DC162	65	MPEG00ADV139	62	3CKFWB	76	MPE1201MD981	77	
MPE1405D3672	65	MPEZ102D6146	62	3CN6A5	79	MPE1202MD979	77	
MPE1405DB159	65	MPEZ102D8148	62	3CNFUB	79	MPE1202MG982	77	
MPE1405DC160	65	VPE000AD0136	68	3CNFUE	79	MPE1204MJ980	77	
MPE1501DV177	72	VPE000ADR127	68	3CNFUF	79	MPE1204ML983	77	
MPE1502DT173	72	VPE000ADT129	68	3CNFUL	79	MPE1211MP190	77	
MPE1505D5179	72	VPE000ADV131	68	3CRFJC	82	MPE1212MR191	77	
MPE1701DK376	72	VPE000ADW132	68	3CRFKC	82	MPE1214MW192	77	
MPE1701DL183	72	VPE000ADZ135	68	3CRFN8	81	MPE1301M3900	79	
MPE1701DM184	72	VPE1101D9150	62	3CRFNB	81	MPE1301MS731	79	
MPE1701DN185	72	VPE5001D2141	68	3CRFNC	81	MPE1301MU769	79	
MPE3302D5163	64	VPE5001D3142	68	3CRFNE	81	MPE1302MV732	79	
MPE3302D6164	64	VPE5101D5389	68	3CRFNF	81	MPE1302MX770	79	
				3CRHRH	83			

* C.N.I.T. = Code National d'Identification du Type (code D2.1 sur nouvelles cartes grises)

Type Mines OU C.N.I.T.*	Encadré N°	Type Mines OU C.N.I.T.*	Encadré N°	Type Mines OU C.N.I.T.*	Encadré N°	Type Mines OU C.N.I.T.*	Encadré N°
MPE1304MM877	79	MPE3505M4939	81	MPE5514M5220	83	10CD62	95
MPE1304MN878	79	MPE3506M4937	81	MPE5515M8221	83	10CD92	96
MPE1305MA935	79	MPE3506MB908	81	MPE5516MC223	83	10CDD2	95
MPE1306M6832	79	MPE3506MN884	81	MPE7511MX309	83	10CDE2	95
MPE1306MS879	79	MPE3506MX930	81	MPE7512M0310	83	10CDF2	95
MPE1311ME195	79	MPE3611MA166	82	MPE7516MA312	83	10CDF4	95
MPE1311MK140	79	MPE3611MV151	82	MPE9312M2520	79	10CDJ2	96
MPE1311MM045	79	MPE3612ME168	81	MPE9316MC522	79	10CDK2	95
MPE1311MN046	79	MPE3612MZ153	81	UPE5211ML175	80	10CE11	86
MPE1312MJ198	79	MPE3614M5155	82	UPE5212MP176	80	10CE12	86
MPE1312MP142	79	MPE3614MK170	82	UPE5214MT177	80	10CG10	86
MPE1312MR048	79	MPE3615M9157	82	UPE5311M6186	80	10CG12	88
MPE1312MS049	79	MPE3615MP172	82	UPE5312M9187	80	10CG22	92
MPE1312MT050	79	MPE3616MD159	82	UPE5316MJ189	80	10CK12	89
MPE1314MP199	79	MPE3616MS174	82	UPE5511MV216	83	10CK22	89
MPE1314MU144	79	MPE5001MG773	78	UPE5514M5220	83	10CKD2	89
MPE1315MS201	79	MPE5002MJ774	78			10SA92	93
MPE1315MY146	79	MPE5004M7880	78	308		10SD92	96
MPE1316M1147	79	MPE5201MS729	84	4ARHRH	85	10SE11	88
MPE1316MV202	79	MPE5202MV730	84	4ARHRJ	85	10SE12	88
MPE1501M2818	81	MPE5204ML874	84	4CRHRH	85	10SG11	88
MPE1501ME733	81	MPE5206M6830	84	4CRHRJ	85	10SG12	88
MPE1502M5819	81	MPE5211MH135	80	4CRHRJ/1	85	2510	86
MPE1502MH734	81	MPE5211ML175	80	MPE5511VQ662	85	2511	86
MPE1504M2873	81	MPE5211MQ241	80	MPE5511VU472	85	2590	86
MPE1505MX938	81	MPE5212MK136	80	MPE5512V1477	85	2591	86
MPE1506MP831	81	MPE5212MP176	80	MPE5512VT663	85	2711	86
MPE1516MG009	81	MPE5212MT242	80	MPE7511V2535	85	2791	86
MPE1611M3165	82	MPE5212MV244	80	MPE7512VE545	85	3AA8B2	94
MPE1611MP150	82	MPE5214MP137	80			3AA9A2	93
MPE1612M7167	81	MPE5214MT177	80	309		3AA9A9	93
MPE1612MS152	81	MPE5301M3827	83	10AA92	93	3AB2B2	92
MPE1614MD169	82	MPE5301M8771	83	10AB11	92	3AB2B4	92
MPE1614MY154	82	MPE5302M6828	83	10AB12	92	3AB2B42	92
MPE1615M2156	82	MPE5302MB772	83	10AB14	92	3AB5A2	92
MPE1615MH171	82	MPE5304MX876	83	10AB22	92	3ABDY2	92
MPE1616M2384	82	MPE5306MF829	83	10AB31	92	3ABDY4	92
MPE1616M6158	82	MPE5311M6186	80	10AB32	92	3ABDZ2	92
MPE1616ML173	82	MPE5311M9286	80	10AB62	92	3AD2A2	95
MPE1705MV977	81	MPE5311MP035	80	10ABA2	92	3AD2H2	95
MPE1711MV183	82	MPE5311MX080	80	10ABA4	92	3AD6B2	95
MPE1712MY184	82	MPE5311MZ179	80	10AD22	95	3AD9A2	96
MPE1715M5185	81	MPE5312M0081	80	10AD62	95	3ADDZ2	95
MPE1715MF256	81	MPE5312M2180	80	10AD64	95	3ADFZ4	95
MPE1715MS075	81	MPE5312M9187	80	10AD92	96	3ADJZ2	96
MPE3301M9900	79	MPE5312MC287	80	10ADD2	95	3ADKZ2	95
MPE3301MP757	79	MPE5312MR036	80	10ADF2	95	3ADKZ4	95
MPE3302MC901	79	MPE5314M5082	80	10ADF4	95	3AE1A2	86
MPE3302MR758	79	MPE5314M7181	80	10ADJ2	96	3AG1A2	88
MPE3304MH902	79	MPE5314ME188	80	10ADK2	95	3AHDZ2	87
MPE3304MW881	79	MPE5314MH288	80	10AE11	86	3AJ2A2	92
MPE3306M1882	79	MPE5314MW037	80	10AE12	86	3AK1D2	89
MPE3306MM903	79	MPE5316M1038	80	10AG12	88	3AK1G2	89
MPE3311MJ194	79	MPE5316M3076	80	10AG22	88	3AK2B2	89
MPE3311MR141	79	MPE5316MA083	80	10AJ22	92	3AK2D2	89
MPE3312MP197	79	MPE5316MC182	80	10AK12	89	3AK3A1	89
MPE3312MV143	79	MPE5316MJ189	80	10AK22	89	3AK3AZ	89
MPE3314M1145	79	MPE5501MW994	83	10AKD2	89	3AKDY2	89
MPE3314MV200	79	MPE5502MZ995	83	10AY22	91	3AKDZ2	89
MPE3316M2203	79	MPE5504M4996	83	10CA92	93	3AY2A2	91
MPE3316M8148	79	MPE5506M9997	83	10CB12	92	3CA8B2	94
MPE3501M7781	81	MPE5511MV216	83	10CB14	92	3CA9A2	93
MPE3501M9916	81	MPE5512MC425	83	10CB62	92	3CA9A9	93
MPE3502MA782	81	MPE5512MZ218	83	10CBA2	92	3CB2A2	86
MPE3502MC917	81	MPE5512MZ290	83	10CBA4	92	3CB2A4	92
				10CD22	95		

* C.N.I.T. = Code National d'Identification du Type (code D2.1 sur nouvelles cartes grises)

Type Mines OU C.N.I.T.*	Encadré N°	Type Mines OU C.N.I.T.*	Encadré N°	Type Mines OU C.N.I.T.*	Encadré N°	Type Mines OU C.N.I.T.*	Encadré N°
3CB2B2	92	15BDK4	104	4BRFX2	108	8BP8CD	122
3CB2B4	92	15BK11	99	4BRFX4	108	8BP8CE	122
3CBDY2	92	15BK11/1	99	4BRFX7	108	8BR6E2	117
3CBDY4	92	15BK11BC	99	4BRFY2	109	8BR6E4	117
3CBDZ2	92	15BK12	99	4BRGZ7	110	8BRFNA	116
3CD2A2	95	15BK121	99	4EB2A2	100	8BRFNR	116
3CD2H2	95	15BK21	99	4EB2A4	100	8BRFRE	116
3CD6B2	95	15BK22	99	4EB5A2	101	8BRFRE/IF	116
3CD6C2	97	15BK31	99	4EBDY2	101	8BRFRR/IF	116
3CD9A2	96	15BK32	99	4EBDY4	101	8BRFV2	116
3CDDZ2	95	15EA82	103	4EBFZ2	101	8BRFV4	116
3CDFW2	97	15EA92	103	4EBFZ4	101	8BRFVD	117
3CDFZ4	95	15EAJ2	103	4ED2H2	104	8BRFVE	117
3CDJZ2	96	15EB12	100	4ED2H4	104	8BRFVN	117
3CDKZ2	95	15EB12/31	100	4ED2H8	104	8BRFVP	117
3CDKZ4	95	15EB32	100	4ED5A2	104	8BRFVT	116
3CE1A2	86	15EB52	100	4ED6D2	104	8BRFVW	116
3CG1A2	88	15EBD2	100	4ED8A2	107	8BRGX2	121
3CHDZ2	87	15EBD4/1	100	4EDHY2	107	8BRGXE	121
3CK1D2	89	15ED22	104	4EDJZ2	105	8BRHSF	119
3CK1G2	89	15ED22/1	104	4EKDX2	99	8BRHYE	120
3CK2B2	89	15ED22/31	104	4EL6A2	102	8BRHYF	120
3CK2D2	89	15ED24	104	4ELFZ2	102	8BRHZE	118
3CKDY2	89	15ED24/1	104	4ELFZ4	102	8BRHZF	118
3CKDZ2	89	15ED24/31	104	4ER6D2	108	8BRHZR	118
3SA9A2	93	15ED52	104	4ER6D4	108	8BRLZF	116
3SD9A2	96	15ED54	104	4ERFX2	108	8BXFXA	126
3SE1A2	86	15ED62	104	4ERFX4	108	8BXFXB	126
3SG1A2	88	15ED62/2	104	4ERFX7	108	8BXFXF	126
3SK1G2	89	15ED64	104	4SB2A2	100	8BXFXR	126
		15ED64/2	104	4SBDY2	101	8BXFZ2	125
405		15ED92	105	4SBFZ2	101	8BXFZ4	125
15B8A2	100	15EDD2	104	4SD9B2	105	8BXFZE	125
15BA82	103	15EDD2/2	104			8BXFZP	125
15BA92	103	15EDD7	104	406		8C3FZA	123
15BAJ2	103	15EDF2	104	8B3FZE	123	8C4HXF	124
15BB12	100	15EDF4	104	8B3FZF	123	8CRFNA	116
15BB12/31	100	15EDF4/2	104	8B4HXF	124	8CRFNR	116
15BB22	100	15EDJ2	105	8B6FZF	112	8CRFR6	116
15BB24	100	15EDK2	104	8B6FZF/GPL	112	8CRFRE	116
15BB32	100	15EDK4	104	8B6FZR	112	8CRFRE/IF	116
15BB52	100	15SD92	105	8BBFZ2	111	8CRFRF	116
15BBD2	100	4BB2A2	100	8BBFZD	111	8CRFRR	116
15BBD4	100	4BB2A4	100	8BBFZE	111	8CRFV2	117
15BBD4/1	100	4BB5A2	101	8BD8B	115	8CRFV8	117
15BD22	104	4BBDY2	101	8BD8B2	115	8CRFVE	117
15BD22/1	104	4BBDY4	101	8BD8BD	115	8CRFVP	117
15BD22/31	104	4BBFZ2	101	8BDHVF	114	8CRFVT	117
15BD22A	104	4BBFZ4	101	8BDHWE	114	8CXFX3	126
15BD24	104	4BD2H2	104	8BDHX2	115	8CXFX6	126
15BD24/1	104	4BD2H4	104	8BDHXE	115	8CXFX9	126
15BD24/31	104	4BD2H6	104	8BDHXP	115	8CXFXA	126
15BD52	104	4BD2H8	104	8BL6A2	113	8CXFXB	126
15BD54	104	4BD5A2	104	8BLFY2	113	8CXFXF	126
15BD621	106	4BD5A4	104	8BLFY8	113	8CXFXR	126
15BD671	106	4BD6D2	104	8BLFYD	113	8CXFZ4	125
15BD92	105	4BD6D4	104	8BLFYE	113	8CXFZE	125
15BDD2	104	4BD8A2	107	8BLFYE/GPL	113	8CXFZP	125
15BDD7	104	4BD9B2	105	8BLFYF/IF	113	8E3FZE	123
15BDF2	104	4BDHY2	107	8BLFYF	113	8E3FZF	123
15BDF2/1	106	4BDJZ2	105	8BLFYF/IF	113	8E4HXF	124
15BDF21	106	4BKDX2	99	8BLFYS	113	8E6FZF	112
15BDF4/2	104	4BL6A2	102	8BLFYT	113	8E6FZF/GPL	112
15BDF7/1	106	4BLFZ2	102	8BLFYT/GPL	113	8E6FZR	112
15BDJ2	105	4BLFZ4	102	8BLFYW	113	8ED8BD	115
15BDK2	104			8BP8C2	122		

* C.N.I.T. = Code National d'Identification du Type (code D2.1 sur nouvelles cartes grises)

Type Mines OU C.N.I.T.*	Encadré N°	Type Mines OU C.N.I.T.*	Encadré N°	Type Mines OU C.N.I.T.*	Encadré N°	Type Mines OU C.N.I.T.*	Encadré N°
8EDHWE	114	MPE000AA0403	113	MPE1402A5029	113	MPE1904AS652	126
8EDHX2	115	MPE000AA1113	113	MPE1402A6030	113	MPE3402AB417	113
8EDHXE	115	MPE000AA1185	117	MPE1402A6418	113	MPE3402AG749	112
8EDHXP	115	MPE000AA1246	113	MPE1402A7031	113	MPE3402AJ036	113
8ELFYE	113	MPE000AA1404	113	MPE1402AD037	113	MPE3404AJ420	113
8ELFYE/1	113	MPE000AA2114	113	MPE1402AD425	113	MPE3404AL750	112
8ELFYE/GPL	113	MPE000AA2186	125	MPE1402AL627	112	MPE3404AP038	113
8ELFYE/IF	113	MPE000AA2405	117	MPE1402AP049	113	MPE3404AQ040	113
8ELFYF	113	MPE000AA3054	121	MPE1402AP630	112	MPE3501A6537	116
8ELFYR/IF	113	MPE000AA3115	113	MPE1404AB419	113	MPE3501A7017	116
8ELFYT	113	MPE000AA3187	125	MPE1404AC032	113	MPE3501AD023	116
8ELFYT/GPL	113	MPE000AA4116	113	MPE1404AD033	113	MPE3501AW721	116
8ELFYW	113	MPE000AA4188	125	MPE1404AD421	113	MPE3501AY468	116
8EP8CE	122	MPE000AA4407	117	MPE1404AE034	113	MPE3502A2010	117
8ER6E2	117	MPE000AA5056	117	MPE1404AE422	113	MPE3502A5534	117
8ERFNA	116	MPE000AA5092	117	MPE1404AF035	113	MPE3502AE022	117
8ERFNR	116	MPE000AA5117	125	MPE1404AG424	113	MPE3502AV718	116
8ERFRE	116	MPE000AA5408	116	MPE1404AJ039	113	MPE3502AX465	117
8ERFRE/IF	116	MPE000AA6057	117	MPE1404AJ427	113	MPE3504A0719	116
8ERFV2	117	MPE000AA6093	117	MPE1404AL041	113	MPE3504A2466	117
8ERFV4	117	MPE000AA6118	125	MPE1404AP953	112	MPE3504A3467	117
8ERFVE	117	MPE000AA7094	117	MPE1404AT631	112	MPE3504A8012	117
8ERFVP	117	MPE000AA7410	116	MPE1404AU632	112	MPE3504AA535	117
8ERFVW	117	MPE000AA8411	117	MPE1501A0016	117	MPE3504AB960	116
8ERGXE	121	MPE000AA9096	122	MPE1501AE612	116	MPE3504AE963	116
8ERHSF	119	MPE000AAA413	117	MPE1501AH457	116	MPE3504AK024	117
8ERHYE	120	MPE000AAL097	122	MPE1502A1015	117	MPE3801AA450	125
8ERHYE/1	120	MPE000AAM098	122	MPE1502A6020	117	MPE3801AC125	125
8ERHYF	120	MPE000AAN002	113	MPE1502AD609	117	MPE3802AA448	125
8ERHZE	118	MPE000AAN099	122	MPE1502AG454	116	MPE3802AC123	125
8ERHZE/1	118	MPE000AAP004	117	MPE1502AN461	117	MPE3804AF449	125
8ERHZF	118	MPE000AAP100	114	MPE1502AU820	116	MPE3804AJ126	125
8ERHZR	118	MPE000AAP101	114	MPE1504A1011	117	MPE3901A7656	126
8ERLZF	116	MPE000AAQ005	122	MPE1504A3013	117	MPE3901A9949	126
8EXFXA	126	MPE000AAQ102	114	MPE1504A4959	116	MPE3902A7654	126
8EXFXB	126	MPE000AAQ235	125	MPE1504A8018	117	MPE3904AC655	126
8EXFXF	126	MPE000AAR006	115	MPE1504AF025	117	MPE5102AW002	114
8EXFXR	126	MPE000AAR236	125	MPE1504AJ610	116	MPE5104A1003	114
8EXFZE	125	MPE000AAS007	122	MPE1504AJ611	117	MPE5202A5813	120
8EXFZP	125	MPE000AAS104	111	MPE1504AL455	117	MPE5202AA042	115
8F6FZF	112	MPE000AAS237	125	MPE1504AM456	117	MPE5202AB043	115
8F6FZR	112	MPE000AAT008	122	MPE1504AS462	117	MPE5202AG691	120
8FDHWE	114	MPE000AAT105	115	MPE1504AZ821	116	MPE5202AM478	120
8FDHXE	115	MPE000AAT238	125	MPE1602AF116	121	MPE5202AV451	120
8FDHXP	115	MPE000AAT396	113	MPE1602AG117	121	MPE5204A0452	120
8FLFYE	113	MPE000AAU009	113	MPE1602AK775	116	MPE5204A1453	120
8FLFYE/IF	113	MPE000AAU106	115	MPE1604A0776	116	MPE5204AA814	120
8FLFYF	113	MPE000AAU178	117	MPE1604AL118	121	MPE5204AB815	120
8FLFYT	113	MPE000AAU239	125	MPE1701AJ862	123	MPE5204AG044	115
8FP8CE	122	MPE000AAU397	113	MPE1702AJ824	123	MPE5204AH045	115
8FRFNA	116	MPE000AAV010	113	MPE1702AK596	123	MPE5204AL692	120
8FRFNR	116	MPE000AAV107	115	MPE1704AA970	123	MPE5204AR479	120
8FRFRE/1	116	MPE000AAV179	117	MPE1704AN825	123	MPE5204AS480	120
8FRFRE/IF	116	MPE000AAV240	125	MPE1801A1447	125	MPE5302A8357	118
8FRFVE	117	MPE000AAV398	113	MPE1801A3122	125	MPE5302AJ974	118
8FRFVP	117	MPE000AAW180	117	MPE1801A5124	125	MPE5302AL783	119
8FRHSF	119	MPE000AAW399	113	MPE1802A1445	125	MPE5302AN469	118
8FRHYF	120	MPE000AAX181	117	MPE1802A3120	125	MPE5302AN688	118
8FRHZE	118	MPE000AAX400	113	MPE1804A6446	125	MPE5302AP046	122
8FRHZF	118	MPE000AAY085	121	MPE1804A8121	125	MPE5302AP047	122
MPE000AA0015	117	MPE000AAY110	113	MPE1901AL554	126	MPE5302AQ048	122
MPE000AA0087	121	MPE000AAY401	113	MPE1901AN653	126	MPE5302AR049	122
MPE000AA0112	113	MPE000AAZ086	121	MPE1901AR585	126	MPE5302AX964	118
MPE000AA0184	117	MPE000AAZ402	113	MPE1901AR948	126	MPE5304A3966	118
MPE000AA0245	113	MPE1402A4416	113	MPE1902AN651	126	MPE5304AD358	118

* C.N.I.T. = Code National d'Identification du Type (code D2.1 sur nouvelles cartes grises)

Type Mines OU C.N.I.T.*	Encadré N°	Type Mines OU C.N.I.T.*	Encadré N°	Type Mines OU C.N.I.T.*	Encadré N°	Type Mines OU C.N.I.T.*	Encadré N°
MPE5304AE359	118	6JXFVJ	132	504A11	136	551A56	147
MPE5304AN975	118	MPE1412PB055	128	504A12	135	551A56/A	147
MPE5304AP976	118	MPE1412PC056	128	504A13	136	551A57	146
MPE5304AQ784	118	MPE1414PH057	128	504A14	135	551A58	146
MPE5304AS470	118	MPE1512P2230	128	504A20	137	551A58A	146
MPE5304AS689	118	MPE1512P4002	130	504A40	138	551A59	147
MPE5304AT435	118	MPE1512P6004	130	504A45	138	551A66	144
MPE5304AT471	118	MPE1512PC337	128	504B12	135	551A71	139
MPE5304AT532	118	MPE1514P7231	128	504B14	135	551A73	139
MPE5304AT690	118	MPE1514P9003	130	504C12	135	551A76	148
MPE5304AU436	118	MPE1514PB005	130	504C14	135	551A77	139
MPE5304AU533	118	MPE1514PH338	128	504D11	136	551A79	148
MPE5304AW050	122	MPE1612PA228	130	504D13	136	551A84	143
MPE5304AX051	122	MPE1614PF229	130	504D20	137	551A86	143
MPE5501AL704	124	MPE1711PT239	131	504D40	138	551A89	143
MPE5502AK701	124	MPE1712PH225	131	504D80	137	551A96	144
MPE5504A7950	124	MPE1712PM000	131	504E20	137	551A99	144
MPE5504AP702	124	MPE1714PM226	131	504EA1	133	551AF4	140
MPE7302A4965	118	MPE1714PR001	131	504F01	133	551AF6	140
MPE7302AF904	118	MPE1911PF205	132	504F11	136	551D11	140
MPE7302AN754	118	MPE3512P2066	130	504F13	136	551D13	140
MPE7302AU955	118	MPE3512P3067	130	504F20	137	551D17	140
MPE7304AK905	118	MPE3512PV095	130	504F40	138	551D18	140
MPE7304AS755	118	MPE3512PW096	130	504F45	138	551D40	145
MPE7304AZ956	118	MPE3514P8068	130	504F80	137	551D48	145
		MPE3514PC097	130	504F81	133	551D50	146
407		MPE3612PB259	130	504H20	137	551D53	147
6D3FYF	131	MPE3614PG260	130	504K40	134	551D55	146
6D3FYH	131	MPE3712PX041	131	504M01	133	551D57	146
6D3FZF	131	MPE3712PY236	131	504M03	133	551D58	146
6D3FZH	131	MPE3714P2042	131	504M20	134	551D58DG	146
6D6FYC	128	MPE3714P3237	131	504M40	138	551D59	147
6D6FZB	128	MPE3902PE998	132	504M45	138	551D86	143
6D9HYB	127	MPE3904PJ999	132	504M51	133	551D89	143
6D9HYC	127	MPE3911PX206	132	504M53	133	551DG1	140
6D9HZC	127	MPE3912PP099	132	504MY1	136	551DH8	146
6DRFJC	130	MPE3914PU100	132	504MY3	136	551F11	140
6DRFJF	130	MPE5312P7207	127	504R48	138	551F13	140
6DRFNB	130	MPE5312PB053	127	504U20	134	551F17	140
6DRFNE	130	MPE5312PQ359	127	504V40	138	551F18	140
6DRHRE	129	MPE5312PY101	127	504V48	138	551F40	145
6DRHRG	129	MPE5314P0523	127	504V57	133	551F50	146
6DRHRH	129	MPE5314P3102	127	504V58	138	551F55	146
6DRHRJ	129	MPE5314PC208	127			551F56	147
6DXFVJ	132	MPE5314PG054	127	505		551F57	146
6E3FYF	131	MPE5511PJ467	129	551A01	139	551F58	146
6E3FYH	131	MPE5512PK006	129	551A03	139	551F58DG	146
6E3FZF	131	MPE5512PQ109	129	551A11	140	551F59	147
6E3FZH	131	MPE5512PS086	129	551A12	142	551F86	143
6E6FYC	128	MPE5514PP007	129	551A13	140	551F89	143
6E6FZB	128	MPE5514PV110	129	551A14	142	551FB1	140
6E9HYB	127	MPE5614PK707	130	551A16	142	551G11	140
6E9HYC	127	MPE7512P7059	129	551A17	140	551G17	140
6E9HZC	127	MPE7512PB257	129	551A18	140	551G58	146
6ERFJC	130	MPE7512PQ103	129	551A19	142	551H11/1	140
6ERFJF	130	MPE7512PY111	129	551A34	143	551H17	140
6ERFNB	130	MPE7514P3112	129	551A36	143	551H17/1	140
6ERFNE	130	MPE7514PC060	129	551A40	145	551H58	146
6ERHRE	129	MPE7514PG258	129	551A44	145	551S11	140
6ERHRG	129	MPE7514PV104	129	551A45	145	551S11/1	140
6ERHRH	129	MPE9612PV649	130	551A46	145	551S17	140
6ERHRJ	129	UPE5314P3102	127	551A48	145	551S17/1	140
6EXFVJ	132			551A50	146	551S17DG	140
6J3FYH	131	504		551A53	146	551S40	145
6JRHRH	129	5040	133	551A54	147	551S48	145
6JXFVH	132	504000	133	551A55	146	551S50	146

* C.N.I.T. = Code National d'Identification du Type (code D2.1 sur nouvelles cartes grises)

Type Mines OU C.N.I.T.*	Encadré N°	Type Mines OU C.N.I.T.*	Encadré N°	Type Mines OU C.N.I.T.*	Encadré N°	Type Mines OU C.N.I.T.*	Encadré N°
551S58	146	6BRGY4	155	MPE1902L5683	168	MPE5306H7765	176
BA815	143	6BSFZ2	160	MPE1902LR547	168	MPE5306HC795	176
BA816	143	6BSFZ4	160	MPE3702L6576	165	MPE5306HF798	176
BA81E	143	6BSKZ2	160	MPE3702LS562	165	MPE5306HP649	176
BA82F	143	6BTHY2	159	MPE3702LX786	165	MPE5306HP650	175
BA82R	143	6BTHYE	159	MPE3712L8117	165	MPE5306HU486	175
BA916	148	6BUFZ2	160	MPE3902L9548	168	VPE000AHP218	172
BA917	148	6BUFZ4	160	MPE3902LN684	168	VPE000AHQ219	172
BA919	148	6BUKZ2	160	MPE3912L8122	168	VPE000AHS221	171
BA91F	148	6BXFZ2	161	MPE5302L0787	163	VPE000AHT222	178
BA91J	148	6BXFZ4	161	MPE5302LB579	163	VPE1406HA204	172
BA91R	148	6BXFZE	161	MPE5312LD120	163	VPE5206HX199	171
BD815	143	6BXFZP	161	MPE5502LB947	167	VPE5306H3486	178
BD81E	143	MPE000AF1205	154	MPE5502LF563	167	VPE5306HA202	178
BF327	143	MPE000AF2206	154	MPE5502LT577	167		
BF816	143	MPE000AF3207	159	MPE5512LD524	164	807	
BF81F	143	MPE000AF4208	161	MPE5512LP280	164	EA3FZC	183
CF221	143	MPE000AF5209	161	MPE5512LP281	164	EA4HWB	184
CF327	143	MPE000AFX201	157	MPE5512LW119	167	EA4HWG	184
		MPE000AFY202	157	MPE7502L0578	167	EARFJC	180
		MPE000AFZ203	154	MPE7512L1118	167	EARFNC	179
604		MPE1502FD191	154			EARFNE	179
604A40	150	MPE1602FP193	155	806		EARHME	182
604A45	150	MPE1802FN196	161	221DC2	171	EARHTB	182
604A46	150	MPE3602F7194	155	221DH2	171	EARHWB	182
604A55	151	MPE3802FU197	161	221DH2/8S	171	EAXFWF	185
604A56	151	MPE5302F3189	157	221DH2/S	171	EB3FZC	183
		MPE5502F4195	159	221LA2	170	EB4HWB	184
		MPE7302FA190	157	221LA2/1	170	EB4HWG	184
605				221PA2	178	EBRFJC	180
6BP8A2	157	607		221PA2/8S	178	EBRFJF	180
6BP8A4	157	9D3FZ2	165	221PA2/S	178	EBRFNC	179
6BP8B2	157	9D3FZ6	165	221RA2	177	EBRFNE	179
6BP8B2/1	157	9D3FZB	165	221RA2/8S	177	EBRFNF	179
6BP8B4	157	9D3FZC	165	221RB2	172	EBRHME	182
6BP8B4/1	157	9D3FZE	165	221RB2/7S	172	EBRRH	181
6BP8C2	158	9D3FZF	165	221RB2/S	172	EBRHTB	182
6BP8C4	158	9D3FZF	165	221RB9	172	EBXFWF	185
6BP8CE	158	9D4HXB	167	AFRFNC	174	MPE1506NV800	179
6BP8CE/IF	158	9D4HXC	167	AFRFNF	174	MPE1616NK232	180
6BP8CP	158	9D4HXG	167	AFRFVB/IF	173	MPE1616NM234	180
6BP9A2	156	9DRFN5	162	AFRHWB	176	MPE1706NG801	183
6BPHZ2	157	9DRFNB	162	AFRHZA	175	MPE1706NH802	183
6BPHZ4	157	9DRFNC	162	AFRHZA/S	175	MPE3506NU926	179
6BPJZ2	156	9DRHSB	163	MPE000AH9441	172	MPE3506NV927	179
6BR2A2	152	9DRHZB	163	MPE000AHE216	170	MPE3616NF451	180
6BR2A8	152	9DXFX2	168	MPE000AHG218	172	MPE3616NG452	180
6BR5A2	152	9DXFX5	168	MPE000AHH219	177	MPE3616NR233	180
6BR6A2	153	9DXFX6	168	MPE000AHJ220	171	MPE3616NT235	180
6BR6A4	153	9DXFXB	168	MPE000AHJ221	171	MPE5306NQ803	182
6BR6A8	153	9DXFXC	168	MPE000AHK222	178	MPE5306NR804	182
6BR6E2	154	9DXFXE	168	MPE1306HN200	170	MPE5306NT806	182
6BR6E4	154	9U3FYH	166	MPE1306HP201	170	MPE5506NE807	184
6BRDZ2	152	9U3FZC	165	MPE1406H1204	172	MPE5506NF808	184
6BRFV2	154	9U3FZF	165	MPE1506HD763	174	MPE5516N0052	184
6BRFV4	154	9U4HXC	167	MPE1506HL796	174	MPE5516NQ333	181
6BRFV9	154	9U4HXG	167	MPE1506HP581	174	MPE5516NR334	181
6BRFVE	154	9URHRH	164	MPE1506HU223	172	MPE5516NZ051	184
6BRFVP	154	9URHSB	163	MPE1606HK203	177	MPE7306N5945	182
6BRFZ2	153	9UXFVJ	169	MPE3506H7582	174	MPE7306N6946	182
6BRFZ4	153	MPE1502LJ833	162	MPE3506HK764	174		
6BRFZ8	153	MPE1502LV713	162	MPE3506HS797	174	1007	
6BRFZ9	153	MPE1702L9549	165	MPE5206HN198	171	KM8HXB	188
6BRGX2	155	MPE1702LG714	165	MPE5206HP199	171	KM8HZB	188
6BRGX4	155	MPE1702LZ575	165	MPE5306H1202	178	KM8HXC	188
6BRGXE	155	MPE1712L1116	165	MPE5306H4762	176	KM9HXC	190
6BRGXP	155	MPE1712LV279	166				
6BRGY2	155						

* C.N.I.T. = Code National d'Identification du Type (code D2.1 sur nouvelles cartes grises)

Type Mines OU C.N.I.T.*	Encadré N°	Type Mines OU C.N.I.T.*	Encadré N°	Type Mines OU C.N.I.T.*	Encadré N°	Type Mines OU C.N.I.T.*	Encadré N°
KMKFUC	187	231G42	199	232J42	199	233JL2	201
KMKFVB	186	231G52	198	232J44	199	233JL4	201
KMNFUC	189	231G82	194	232J52	198	233K22	195
MPE1111R2367	186	231GH2	201	232J54	198	233K4	199
MPE1111R4685	186	231GL2	201	232J92	198	233K52	198
MPE1111RG090	186	231H22	195	232J94	199	233K52/1	198
MPE1111RJ092	186	231H42	199	232JH2	201	233K54	198
MPE1111RV227	186	231H52	198	232JL2	201	233KH2	201
MPE1211RJ277	187	231H82	194	232JL4	201	233KL2	201
MPE1311RQ687	189	231HL2	201	232K22	195	233KL2/1	201
MPE1311RX306	189	231J42	199	232K52	198	233KL4	201
MPE3311RX688	189	231J52	198	232K54	198	233L22	195
MPE5011R3682	188	231JL2	201	232KH2	201	233L42	199
MPE5011RG088	188	231U42	199	232KL2	201	233L42/1	199
MPE5011RG113	188	231U82	194	232KL4	201	233L44	199
MPE5011RH114	188	231V22/D	195	232L22	195	233L52	198
MPE5311RR360	190	231V24	195	232L44	199	233L52/1	198
MPE5311RY683	190	231V42	199	232L52	198	233L54	198
UPE5011RH114	188	231V52	198	232L54	198	233LL4	201
UPE5311RR360	190	231V52/D	198	232L92	198	233N42	199
		231V54/D	198	232LL4	201	233N44	199
		231V82	193	232N42	199	234G42	199
		231V94	198	232N44	199	234G52	198
		231VH2/D	201	232V22/D	195	234GH2	201
		231VL2/D	201	232V24	195	234GL2	201
		232B02	198	232V44	199	234K42	199
		232B22	195	232V52	198	234K52	198
		232B22/1	195	232V52/D	198	234KH2	201
		232B24	195	232V52/G	198	234KL2	201
		232B42	199	232V52/H	198	MPE000AE0277	198
		232B42/1	199	232V54/D	198	MPE000AE5282	198
		232B44	199	232V94	198	MPE000AE6283	198
		232B52	198	232VH2/D	201	MPE000AE8285	198
		232B52/1	198	232VH2/G	201	MPE000AE9286	195
		232B54	198	232VH2/H	201	MPE000AEA190	195
		232B72	194	232VL2/D	201	MPE000AEA251	195
		232B82	193	232VL2/G	201	MPE000AEA287	195
		232B92	198	232VL2/H	201	MPE000AEB252	198
		232B94	199	233B22	195	MPE000AEC192	194
		232BH2/1	201	233B42	199	MPE000AEC253	198
		232BL2	201	233B52	198	MPE000AEC289	195
		232BL2/1	201	233BL2	201	MPE000AED254	194
		232BL4/1	201	233F42	199	MPE000AEE255	194
		232E82	194	233F82	194	MPE000AEV200	198
		232F42	199	233G22	195	MPE000AEX274	198
		232F82	194	233G42	199	MPE000AEX299	198
		232G22	195	233G42/1	199	MPE000AEY275	198
		232G42	199	233G52	198	MPE000AEZ276	198
		232G42/1	199	233G52/1	198	MPE000AEZ301	198
		232G52	198	233G82	194	MPE1303E1514	195
		232G82	194	233GH2	201	MPE1303EJ496	195
		232GH2	201	233GL2	201	MPE1303EQ503	195
		232GL2	201	233GL2/1	201	MPE1303EZ512	195
		232GL4	201	233H22	195	MPE1403E4834	195
		232H22	195	233H42	199	MPE1403E5835	195
		232H42	199	233H42/1	199	MPE1403EE844	195
		232H42/1	199	233H52	198	MPE5203E8325	193
		232H44	199	233H82	194	MPE5203E8846	196
		232H52	198	233HL2	201	MPE5203E9520	198
		232H82	194	233J22	195	MPE5203EA521	198
		232H92	198	233J42	199	MPE5203EN789	196
		232HL2	201	233J44	199	MPE5203EP342	198
		232HL4	201	233J52	198	MPE5203EP791	196
		232J02	198	233J54	198	MPE5203EQ343	198
		232J12	195	233J92	198	MPE5203EQ792	196
		232J22	195	233JH2	201	MPE5203ER344	198

* C.N.I.T. = Code National d'Identification du Type (code D2.1 sur nouvelles cartes grises)

Type Mines OU C.N.I.T.*	Encadré N°	Type Mines OU C.N.I.T.*	Encadré N°	Type Mines OU C.N.I.T.*	Encadré N°	Type Mines OU C.N.I.T.*	Encadré N°
MPE5203ER502	193	ZBZMA	201	BERFNF	207	J5	
MPE5203EW507	198	ZBZMD	201	BERHZB	208		
MPE5203EY836	196	ZBZMF	201	BHRHZB	208	280A11	212
MPE5203EZ837	196	ZBZMG	201	BSRHXA	209	280A11M	212
MPE5303E4505	198	ZBZMH	201	BSRHXB	209	280B62	213
MPE5303E5348	198	ZBZMN	201	BSRHZB	208	280C22	214
MPE5303E6349	198	ZCPAF	201	BTRHWP	210	280C221	214
MPE5303E7350	198	ZCPMD	201	BTWJYB	205	280C51	215
MPE5303E8351	198	ZCPMF	201	BTWJZA	205	280C511	215
MPE5303E9352	198	ZCPMH	201	BWDHXA	206	280C52	215
MPE5303EF516	198	ZCPMM	201	BYDHXA	206	280C521	215
MPE5303EG517	198	ZCPWA	201	BYRHXA	209	280C82	213
MPE5303EH518	198	ZCPWC	201	BYRHXB	209	280C92	217
MPE5303EK909	197	ZCPWD	201	BYRHZB	208	280C94	217
MPE5303EL910	197	ZCPWN	201	BZDHXA	206	280G22	214
MPE5303EM911	197	ZCRMMD	197	BZRFNC	207	280G221	214
MPE5303EN912	197	ZCRMF	197	BZRHWP	210	280G222	214
MPE5303EP913	197	ZCRMH	197	BZRHXA	209	280G223	214
MPE5303EY499	198	ZCRMM	197	BZRHXB	209	280G224	214
MPE5503E4679	201	ZCTMF	195	BZWJYB	205	280G225	214
MPE5503E5680	201	ZCTMM	195	BZWJZA	205	280G226	214
MPE5503E6850	201	ZCZMA	201	MPE1503G1589	207	280G227	214
MPE5503E8852	201	ZCZMC	201	MPE1503G2590	207	280G22M	214
MPE5503E9853	201	ZCZMD	201	MPE1503G9863	207	280G52	215
MPE5503EP675	201	ZCZMF	201	MPE1513G5010	207	280G521	215
MPE5503ER677	201	ZCZMG	201	MPE1513G6011	207	280G522	215
MPE5503EW840	201	ZCZMH	201	MPE1513G8013	207	280G523	215
MPE5503EY842	201	ZCZMN	201	MPE1513G9014	207	280G524	215
MPE6203EW346	198	Expert		MPE3503GG634	207	280G525	215
MPE6303E2500	198				MPE3503GH635	207	280G526
MPE6303E8506	198	222AA2	202	MPE3513G0071	207	280G527	215
MPE6303EL519	199	222DA2	206	MPE3513G1072	207	280H22	214
MPE6306EP261	198	222DB2	204	MPE3513G2073	207	280H52	215
MPE7503ED851	201	222LA9	203	MPE3513GG015	207	280H92	217
MPE7503EH855	201	222LB9	203	MPE3513GZ070	207	28G224M	214
VPE5303EP516	199	223AA2	202	MPE5103GX225	204	290A62	213
ZAAMF	196	223DA2	206	MPE5303G3865	208	290B54	216
ZAAMP	196	223DB2	204	MPE5303G5637	208	290B62	213
ZAPAP	201	223DH2	206	MPE5303G6638	208	290B94	217
ZAPMF	201	224AA2/5	202	MPE5303G7639	210	290C02	213
ZAPMP	201	224AA2/6	202	MPE5313G7020	208	290C22	214
ZARMF	197	224AA2/8	202	MPE5313G9022	208	290C42	214
ZARMP	197	224AA2/9	202	MPE5313GA023	208	290C52	216
ZATMF	195	224DA2	206	MPE5313GH030	208	290C54	216
ZBAMD	196	224DB2	204	MPE5313GJ031	208	290C92	217
ZBAMF	196	224DH2	206	MPE5313GJ032	208	290C94	217
ZBAMNB	196	224LA9	203	MPE5313GK033	208	290G221	214
ZBAMP	196	224LB9	203	MPE5313GL034	208	290G222	214
ZBPAF	201	225DA2	206	MPE5414GL349	211	290G223	214
ZBPAP	201	226DA2	206	MPE5514GK399	211	290G224	214
ZBPMD	201	BARFNC	207	XARHKH	211	290G42	214
ZBPMFB	201	BARFNF	207	XARHRH	211	290G52	216
ZBPMFBAY	201	BARHWP	210	XCRHKH	211	290G521	216
ZBPMH	201	BARHZB	208	XCRHRH	211	290G522	216
ZBPMP	201	BBRFNC	207	XDRHKH	211	290G523	216
ZBPWF	201	BBRFNF	207	XDRHRH	211	290G524	216
ZBPWN	201	BBRHZB	208	XERHKH	211	290G525	216
ZBRMD	197	BCRHZB	208	XERHRH	211	290G526	216
ZBRMF	197	BDRFNC	207	XFRHKH	211	290G527	216
ZBRMH	197	BDRFNF	207	XGRHKH	211	290G541	216
ZBRMN	197	BDRHWP	210	XSRHKH	211	290G62	213
ZBRMNB	197	BDRHZ	208	XTRHKH	211	290G921	217
ZBRMP	197	BDRHZA	208	XTRHRH	211	290G922	217
ZBTMF	195	BDRHZB	208	XURHKH	211	290G923	217
ZBTMP	195	BERFNC	207	XVRHKH	211	290G924	217
				XWRHKH	211	290G926	217

* C.N.I.T. = Code National d'Identification du Type (code D2.1 sur nouvelles cartes grises)

Type Mines OU C.N.I.T.*	Encadré N°	Type Mines OU C.N.I.T.*	Encadré N°	Type Mines OU C.N.I.T.*	Encadré N°	Type Mines OU C.N.I.T.*	Encadré N°
290G941	217	5BHDZD	223	GJRHYK	231		
290K32	214	5BHDZE/GPL	223	GJWJYB	229		
290K42	214	5BHFXF	223	MPE000ACA120	225		
290K52	216	5BK5A2	225	MPE000ACB121	230		
290M62	213	5BK5AG	225	MPE000ACC061	225		
290R62	213	5BK6C2	225	MPE000ACC122	230		
J9		5BKFXD	225	MPE000ACD062	230		
888A10	218	5BKFXE/GPL	225	MPE000ACG417	225		
888A30	219	5BRHYE	231	MPE1104C0109	225		
888A30/1	219	5BRHYF	231	MPE1104C5599	225		
888A31	219	5BWJYF	229	MPE1104CW396	225		
888A31/1	219	5BWJZE	229	MPE1104CX106	225		
888A33	219	5BWJZT	229	MPE1104CY107	225		
888A33/1	219	5CD9BD	230	MPE1104CY664	225		
888A35	219	5CKFXD	225	MPE1303CJ922	227		
888A35/1	219	5CKFXE	225	MPE1303CK923	227		
888A39	219	5CKFXE/GPL	225	MPE1313CN246	227		
888A39/1	219	5CRHYE	231	MPE5103C7918	229		
888A60	220	5CRHYF	231	MPE5103C8919	229		
888A70	222	5CWJYF	229	MPE5104C0715	229		
888A70/1	222	5CWJZE	229	MPE5104C3330	229		
888A71	222	5DHDZE	224	MPE5104C4331	229		
888A71/1	222	5EK5AG	225	MPE5104CC400	229		
888A73	221	5FA9AD	228	MPE5104CD401	229		
888A73/1	222	5FDJYE	230	MPE5113C5139	229		
888A75	221	5FHDZD	224	MPE5203CN924	231		
888A75/1	222	5FHDZE	224	MPE5203CP925	231		
888A79	222	5FK5A2	225	MPE5204CC778	231		
888A79/1	222	5FK5AG	225	MPE5204CD779	231		
888B31	219	5FK6C2	225	MPE5204CE780	231		
888B31/1	219	5FKFWF	225	MPE5204CM666	231		
888B71	221	5FKFWF/GPL	225	MPE5204CX605	231		
888B71/1	222	5FKFXD	225	MPE9103CY933	226		
888C30	219	5FKFXE	225	MPE9113CE039	226		
888C30/1	219	5FKFXE/GPL	225	VPE000ACL122	229		
888C33	219	5FKFXF	225	VPE5004CF113	229		
888C33/1	219	5FNFUF	227				
888C39	219	5FNFUU	227				
888C70	222	5FRHYE	231				
888C70/1	222	5FRHYF	231				
888C73	222	5FRHYU	231				
888C73/1	222	5FWJYF	229				
888C76	222	5FWJZE	229				
888C79	221	5FWJZT	229				
888C79/1	222	GBHFXB	223				
888D33	219	GBKFWB	226				
888D33/1	219	GBKFWBGL	226				
888D35	219	GBKFWC	226				
888D35/1	219	GBKFWCGN	226				
888D39	219	GBNFUB	227				
888D39/1	219	GBRHYB	231				
888D73	221	GBWJYB	229				
888D73/1	222	GBWJYBDG	229				
888D75	221	GBWJYBDGL	229				
888D75/1	222	GCKFWB	226				
888D79	222	GCKFWBGNV	226				
888D79/1	222	GCKFWBGPL	226				
		GCRHYB	231				
		GCRHYBDG	231				
		GCRHYBDGL	231				
		GCVJYB	229				
		GJKFWB	226				
		GJKFWBGPL	226				
		GJNFUB	227				
		GJNFUC	227				
		GJRHYB	231				
Partner							
5AHDZA	223						
5AHDZE/GPL	223						
5AHFXF	223						
5BA9AD	228						
5BD9BD	230						
5BDJYE	230						

* C.N.I.T. = Code National d'Identification du Type (code D2.1 sur nouvelles cartes grises)

IDENTIFICATION JOINTS DE CULASSE - Moteur Diesel CYLINDER HEAD GASKET IDENTIFICATION - Diesel Engine PEUGEOT - CITROËN - Moteur XUD7 Atmo / XUD7 N.A. Engine

Moteurs / Engines XUD7 Atmo / N.A. → Alésage / Bore = 80 mm - 1769 cm³

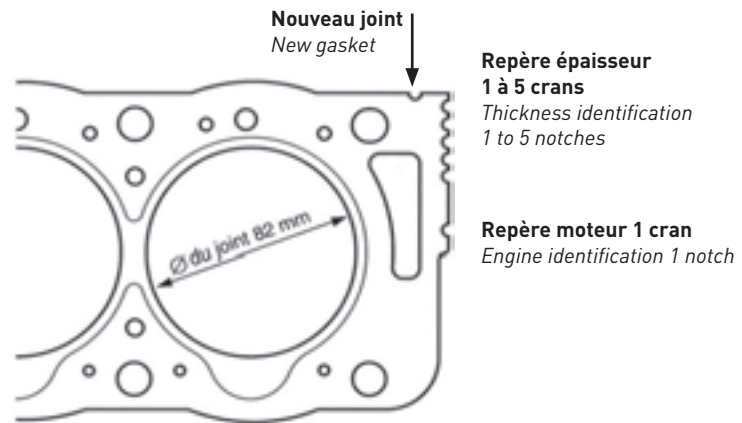
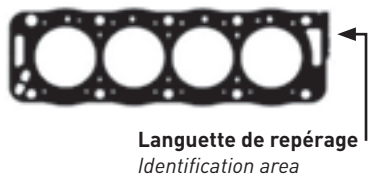

ANCIENS JOINTS FIBREUX (3 épaisseurs différentes) OLD FIBER GASKETS (3 different thicknesses)

	} 1 Cran / Notch
	} 2 Crans / Notches
	} 3 Crans / Notches

NOUVEAUX JOINTS FIBREUX (5 épaisseurs différentes) NEW FIBER GASKETS (5 different thicknesses)

	} 1 Cran / Notch	BX 830 Ép. / Thick. = 1,36 mm*
	} 2 Crans / Notches	BX 840 Ép. / Thick. = 1,40 mm*
	} 3 Crans / Notches	BX 850 Ép. / Thick. = 1,44 mm*
	} 4 Crans / Notches	BX 860 Ép. / Thick. = 1,48 mm*
	} 5 Crans / Notches	BX 870 Ép. / Thick. = 1,52 mm*

* L'épaisseur correspond à l'épaisseur serrée sur moteur.
* The above thickness refers to the assembled thickness.



Attention: mesurer systématiquement les dépassements de pistons au PMH pour déterminer le joint de culasse d'épaisseur optimale (voir les notes techniques en fin de catalogue pour identifier la correspondance entre le dépassement du piston et la réf. de joint).

Warning: it is strongly recommended that the gasket selection be made after measuring the UDC piston protrusion; see the technical notes at the end of the catalogue to have the link between the piston protrusion and the gasket part number.

IDENTIFICATION JOINTS DE CULASSE - Moteur Diesel CYLINDER HEAD GASKET IDENTIFICATION - Diesel Engine PEUGEOT - CITROËN - Moteur XUD7 Turbo / XUD7 T.C. Engine

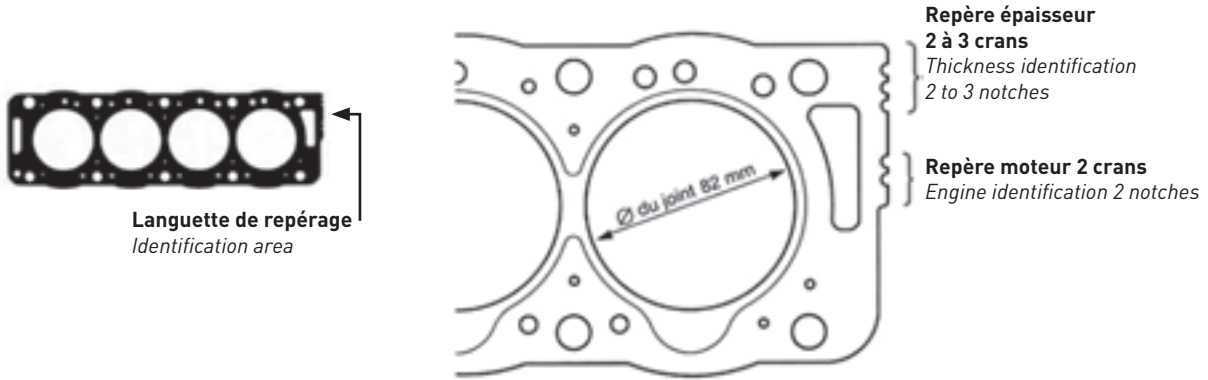
Moteurs / Engines XUD7 Turbo / T.C. → Alésage / Bore = 80 mm - 1769 cm³



 } 2 Crans / Notches	 } 3 Crans / Notches
BX 780 Ép. / Thick. = 1,65 mm*	BX 790 Ép. / Thick. = 1,80 mm*
* L'épaisseur indiquée correspond à l'épaisseur libre (avant montage). * The above thickness refers to the thickness before the assembly of the engine.	

Attention: mesurer systématiquement les dépassements de pistons au PMH pour déterminer le joint de culasse d'épaisseur optimale (voir les notes techniques en fin de catalogue pour identifier la correspondance entre le dépassement du piston et la réf. de joint).

Warning: it is strongly recommended that the gasket selection be made after measuring the UDC piston protusion; see the technical notes at the end of the catalogue to have the link between the piston protusion and the gasket part number.

IDENTIFICATION JOINTS DE CULASSE - Moteur Diesel CYLINDER HEAD GASKET IDENTIFICATION - Diesel Engine PEUGEOT - CITROËN - Moteur XUD9 Atmo / XUD9 N.A. Engine

Moteurs / Engines XUD9 Atmo / N.A. → Alésage / Bore = 83 mm - 1905 cm³

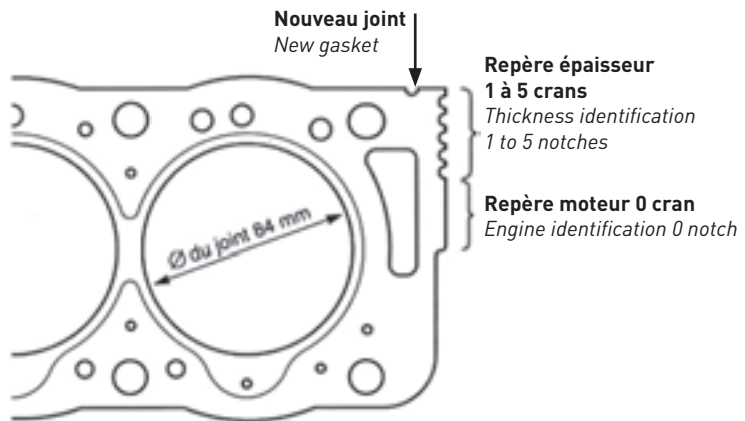
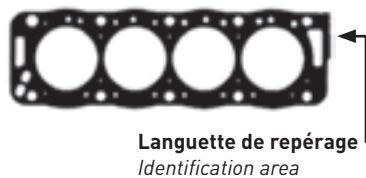

ANCIENS JOINTS FIBREUX (3 épaisseurs différentes) <i>OLD FIBER GASKETS</i> <i>(3 different thicknesses)</i>	
	} 2 Crans / Notch
	} 3 Crans / Notches
	} 4 Crans / Notches

Ces joints ne sont plus disponibles.
The gaskets are deleted.

NOUVEAUX JOINTS FIBREUX (5 épaisseurs différentes) <i>NEW FIBER GASKETS (5 different thicknesses)</i>		
	} 1 Cran / Notch	BX 880 Ép. / Thick. = 1,36 mm*
	} 2 Crans / Notches	BX 890 Ép. / Thick. = 1,40 mm*
	} 3 Crans / Notches	BX 900 Ép. / Thick. = 1,44 mm*
	} 4 Crans / Notches	BX 910 Ép. / Thick. = 1,48 mm*
	} 5 Crans / Notches	BX 920 Ép. / Thick. = 1,52 mm*

* L'épaisseur correspond à l'épaisseur serrée sur moteur.
* The above thickness refers to the assembled thickness.

Attention: mesurer systématiquement les dépassements de pistons au PMH pour déterminer le joint de culasse d'épaisseur optimale (voir les notes techniques en fin de catalogue pour identifier la correspondance entre le dépassement du piston et la réf. de joint).

Warning: it is strongly recommended that the gasket selection be made after measuring the UDC piston protrusion; see the technical notes at the end of the catalogue to have the link between the piston protrusion and the gasket part number.

IDENTIFICATION JOINTS DE CULASSE - Moteur Diesel CYLINDER HEAD GASKET IDENTIFICATION - Diesel Engine PEUGEOT - CITROËN - Moteur XUD9 Turbo / XUD9 T.C. Engine

Moteurs / Engines XUD9 Turbo / T.C. → Alésage / Bore = 83 mm - 1905 cm³

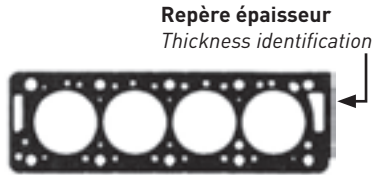



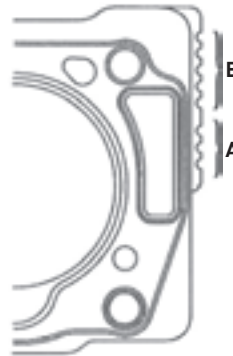

Joint métal-élastomère PAYEN
Steel elastomer gasket PAYEN
A = Repère moteur = 3 crans
A = Engine identification = 3 notches
B = Repère épaisseur = 1 à 5 crans
B = Thickness identification = 1 to 5 notches

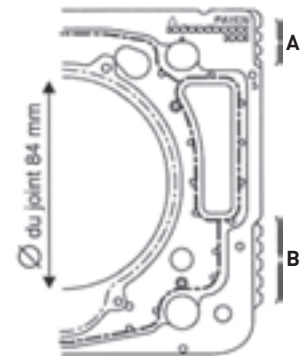





Joint métallique multifeuille
Multi-layer steel gasket
(ELRING)

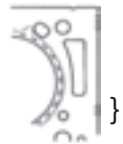

Joint métal-élastomère
Steel elastomer gasket
PAYEN

ANCIENS JOINTS FIBREUX OLD FIBER GASKETS	
 } 1 Cran / Notch	
 } 2 Crans / Notches	BV 920
 } 3 Crans / Notches	BV 930
 } 4 Crans / Notches	

NOUVEAUX JOINTS METAL-ELASTOMERE (5 + 1 épaisseurs différentes) STEEL ELASTOMER GASKETS (5 + 1 different thicknesses)	
 } 1 Cran / Notch	BX 930 Ép. / Thick. = 1,36 mm*
 } 2 Crans / Notches	BX 940 Ép. / Thick. = 1,40 mm*
 } 3 Crans / Notches	BX 950 Ép. / Thick. = 1,44 mm*
 } 4 Crans / Notches	BX 960 Ép. / Thick. = 1,48 mm*
 } 5 Crans / Notches	BX 970 Ép. / Thick. = 1,52 mm*
 } 0 Cran / Notch	BX 980 Ép. / Thick. = 1,59 mm* Pour bloc rectifié For resurfaced block

* L'épaisseur indiquée correspond à l'épaisseur serrée sur moteur.
* The above thickness refers to the assembled thickness.

IDENTIFICATION JOINTS DE CULASSE - Moteur Diesel CYLINDER HEAD GASKET IDENTIFICATION - Diesel Engine PEUGEOT - CITROËN - Moteur / Engine XUD11 ATA et / and BTE

Moteurs / Engines XUD11 ATE et / and BTE → Alésage / Bore = 85 mm - 2088 cm³

Anciens joints de culasse fibreux 4 épaisseurs
Old fiber gaskets (4 different thicknesses)

Nouveaux joints métalliques multifeuilles (5+2 classes)
New multi-layer steel gaskets

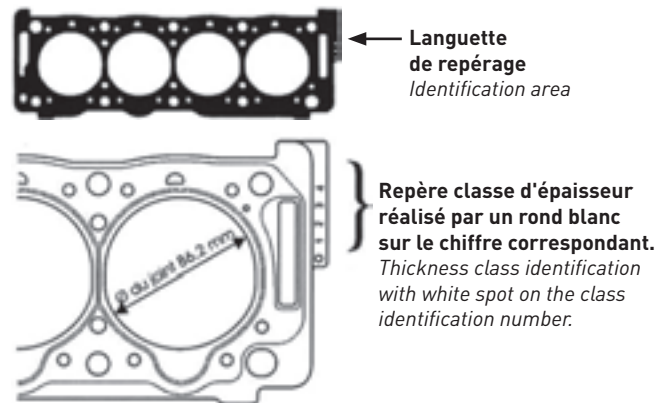
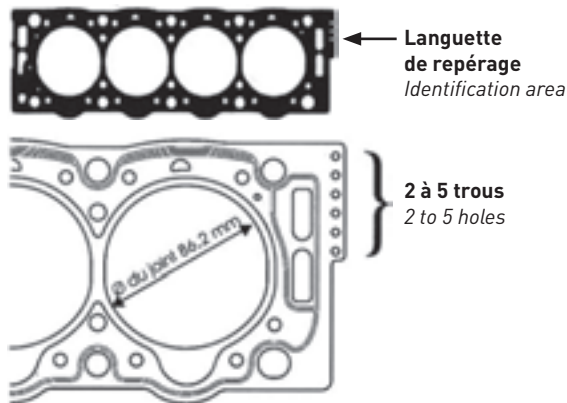

ANCIENS JOINTS FIBREUX (4 épaisseurs différentes) <i>OLD FIBER GASKETS</i> <i>(4 different thicknesses)</i>	
	2 Trous / Holes
	3 Trous / Holes
	4 Trous / Holes
	5 Trous / Holes

ANCIENS JOINTS FIBREUX (5 classes) <i>OLD FIBER GASKETS</i> <i>(3 classes)</i>	NOUVEAUX JOINTS MÉTALLIQUES MULTIFEUILLES (3 + 2 classes) <i>NEW MULTI-LAYER STEEL GASKETS</i> <i>(3 + 2 classes)</i>	
		BY 930 Classe / Class 0 (1 + 2 trous / holes) Ép. / Thick. = 1,35 mm*
		BY 941 Classe / Class 1 Ép. / Thick. = 1,52 mm*
		BY 961 Classe / Class 2 Ép. / Thick. = 1,62 mm*
		BY 981 Classe / Class 3 Ép. / Thick. = 1,72 mm*
		BY 990 Classe / Class 6 (1 + 4 trous / holes) Ép. / Thick. = 1,77 mm*

Attention: mesurer systématiquement les dépassements de pistons au PMH pour déterminer le joint de culasse d'épaisseur optimale (voir les notes techniques en fin de catalogue pour identifier la correspondance entre le dépassement du piston et la réf. de joint).

Warning: it is strongly recommended that the gasket selection be made after measuring the UDC piston protrusion; see the technical notes at the end of the catalogue to have the link between the piston protrusion and the gasket part number.

* L'épaisseur correspond à l'épaisseur serrée sur moteur.
* The above thickness refers to the assembled thickness.

IDENTIFICATION JOINTS DE CULASSE - Moteur Diesel CYLINDER HEAD GASKET IDENTIFICATION - Diesel Engine PEUGEOT - CITROËN - Moteur DW8 Atmo / DW8 N.A. Engine

Moteurs / Engines DW8 Atmo / DW8 N.A.

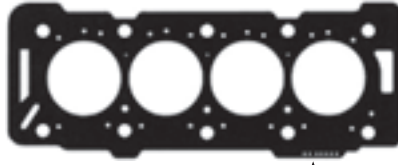

Languette de repérage
Identification area

	1 Trou /Hole	AA5830 Ép. / Thick. = 1,26 mm*
	2 Troux /Holes	AA5840 Ép. / Thick. = 1,30 mm*
	3 Troux /Holes	AA5850 Ép. / Thick. = 1,34 mm*
	4 Troux /Holes	AA5860 Ép. / Thick. = 1,38 mm*
	5 Troux /Holes	AA5870 Ép. / Thick. = 1,42 mm*
	2 Troux /Holes	AA5880 Ép. / Thick. = 1,46 mm*
<p>* L'épaisseur correspond à l'épaisseur serrée sur moteur. * The above thickness refers to the assembled thickness.</p>		

Attention: mesurer systématiquement les dépassements de pistons au PMH pour déterminer le joint de culasse d'épaisseur optimale (voir les notes techniques en fin de catalogue pour identifier la correspondance entre le dépassement du piston et la réf. de joint).



Warning: it is strongly recommended that the gasket selection be made after measuring the UDC piston protrusion; see the technical notes at the end of the catalogue to have the link between the piston protrusion and the gasket part number.

IDENTIFICATION JOINTS DE CULASSE - Moteur Diesel CYLINDER HEAD GASKET IDENTIFICATION - Diesel Engine PEUGEOT - CITROËN - Moteur DW10 Turbo / DW10 T.C. Engine

Moteurs / Engines DW10 Turbo / DW10 T.C.



Languette de repérage
Identification area

	1 Cran /Noth	AC5011 Ép. / Thick. = 1,30 mm*
	3 Crans /Nothes	AC5031 Ép. / Thick. = 1,40 mm*
	5 Crans /Nothes	AC5051 Ép. / Thick. = 1,50 mm*
<p>* L'épaisseur correspond à l'épaisseur serrée sur moteur. * The above thickness refers to the assembled thickness.</p>		

Attention: mesurer systématiquement les dépassements de pistons au PMH pour déterminer le joint de culasse d'épaisseur optimale (voir les notes techniques en fin de catalogue pour identifier la correspondance entre le dépassement du piston et la réf. de joint).

Warning: it is strongly recommended that the gasket selection be made after measuring the UDC piston protrusion; see the technical notes at the end of the catalogue to have the link between the piston protrusion and the gasket part number.



KW/PS



104 1.0L					09/83 → 06/88	1		
XV8 (108C)	954	4	70.00	Carburettor	33/45	BF290 (Fibre), 1.20mm [33] (30-023670-10) →11/85 BN570 (Fibre), 1.20mm [35] (30-026351-10) 11/85→	DN571▲	EH950 [36]
104 1.1L					08/80 → 06/88	2		
104 Coupe 1.1L					08/79 → 06/88			
XW7 (109F)	1124	4	72.00	Carburettor	37/50	BH950 (Fibre), 1.20mm, 1 Notch [33] (30-025152-10) →11/85 BL620 (Fibre), 1.40mm [33] [34] →11/85 BN580 (Fibre), 1.20mm [35] (30-026021-10) 11/85→	DN571▲	EH950 [36]
104 Coupe 1.1L					09/73 → 09/79	3		
XW3S	1124	4	72.00	Carburettor	48/65	BH950 (Fibre), 1.20mm, 1 Notch [33] (30-025152-10) BL620 (Fibre), 1.40mm [33] [34]	DN571▲	EH950 [36]
104 1.2L					08/79 → 06/83	4		
XZ5 (129)	1219	4	75.00	Carburettor	42/57	BH950 (Fibre), 1.20mm, 1 Notch [33] (30-025152-10) BL620 (Fibre), 1.40mm [33] [34]	DN571▲	EH950 [36]

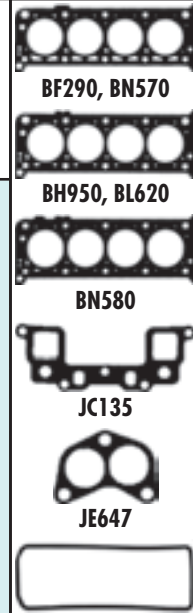
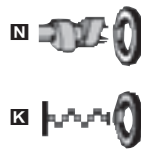
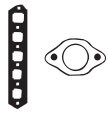

JC135 11/85 →

JN596 (50-023671-00)

● PA349 (33-102290-10) 22x16x2mm

HR300

NF678 35x50x8mm, ACM
 NF641 78x100x10mm, MVQ

HR571 [37] → Eng. 6.335.440
HR564 [37] Eng. 6.335.441 →
NF526 (x2) [2]
NF334 (x2) [38]
NF836 (x2) [38]
HG108 [39] [40]
HL442 [39] [41]
NF735 (x2) [42]
HG087 [43] [44]
LV847 [45]
LT832 [46]

JC135 JE647 [47] (31-022193-10)

JN596 (50-023671-00)

● PA349 (33-102290-10) 22x16x2mm

HR300

NF678 35x50x8mm, ACM
 NF641 78x100x10mm, MVQ

HR564 [37]
NF526 (x2) [2]
NF334 (x2) [38]
NF836 (x2) [38]
HG108 [39] [40]
HL442 [39] [41]
NF735 [42]
HG087 [43] [44]
HG104 [43] [48]
LV847 [45]
LT832 [46]

JC135 01/80 → JE647 [47] (31-022193-10)

JN596 (50-023671-00)

● PA349 (33-102290-10) 22x16x2mm

HR300

NF678 35x50x8mm, ACM
 NF641 78x100x10mm, MVQ

HR571 [37] → 12/79
HR564 [37] 01/80 →
NF526 (x2) [2]
NF334 (x2) [38]
NF836 (x2) [38]
HG108 [39] [40]
HL442 [39] [41]
NF735 [42]
HG087 [43] [44]
LV847 [45]
LT832 [46]

JN596 (50-023671-00)

● PA349 (33-102290-10) 22x16x2mm

HR300

NF678 35x50x8mm, ACM
 NF641 78x100x10mm, MVQ

HR564 [37]
NF526 (x2) [2]
NF334 (x2) [38]
NF836 (x2) [38]
HG108 [39] [40]
HL442 [39] [41]
NF735 [42]
HG087 [43] [44]
HG104 [43] [48]
LV847 [45]
LT832 [46]



KW/PS



104 1.4L						08/79 → 06/83	5	BH950 (Fibre), 1.20mm, 1 Notch [33]		DN582▲	EH950 [36]	
104 Coupe 1.4L						08/79 → 06/84						
XY6B (150)	1360	4	75.00	Carburettor	53/72			→01/82 BL620 (Fibre), 1.40mm [33] [34] →01/82 BN580 (Fibre), 1.20mm [35] (30-026021-10) 01/82→				
106 1.0L						09/91 → 04/96		6	BS810 (Fibre), 1.30mm (30-026850-00) BR490 (Fibre), 1.50mm [34] (30-029800-00)		DS810 (21-26850-20/0) DT012▲ (21-26853-20/0)	EH951 [8] (22-25605-00/0) EH952 (22-25605-02/0)
TU9M (CDY)/TU9M (CDZ)	954	4	70.00	SPi	37/50							
106 1.0L i						05/96 →		7	BS810 (Fibre), 1.30mm (30-026850-00) BR490 (Fibre), 1.50mm [34] (30-029800-00)		DS810 (21-26850-20/0) DT012▲ (21-26853-20/0)	EH951 [8] (22-25605-00/0) EH952 (22-25605-02/0)
TU9M (CDY)/TU9M (CDZ)	954	4	70.00	SPi	37/50							
106 1.1L						09/91 → 04/96		8	AD5700 (Fibre), 1.25mm (30-026851-00) AD5710 (Fibre), 1.50mm [34] (30-029799-00)		DT010 (21-26851-20/0) DT012▲ (21-26853-20/0)	EH951 [8] (22-25605-00/0) EH952 (22-25605-02/0)
TU1M (HDZ)	1124	4	72.00	SPi	44/60							
106 1.1L						09/91 →		9	AD5700 (Fibre), 1.25mm (30-026851-00) AD5710 (Fibre), 1.50mm [34] (30-029799-00)		DT010 (21-26851-20/0) DT012▲ (21-26853-20/0)	EH951 [8] (22-25605-00/0)
TU1 (H1A/H1B/H3A)	1124	4	72.00	Carburettor	40/54							
106 1.1L i						05/96 →		10	AD5700 (Fibre), 1.25mm (30-026851-00) TU1M AC5700 (Fibre), 1.26mm (30-029572-00) TU1JP AD5710 (Fibre), 1.50mm [34] (30-029799-00) TU1M		CC5700 (21-29572-20/0) TU1JP DT010 (21-26851-20/0) TU1M DT012▲ (21-26853-20/0) TU1M	EH951 [8] (22-25605-00/0) TU1M EH952 (22-25605-02/0) TU1M
TU1JP (HFX) TU1M (HDZ)	1124 1124	4 4	72.00 72.00	MPi SPi	44/60 44/60							
106 1.1L i						01/97 →		11	BS810 (Fibre), 1.30mm (30-026850-00) BR490 (Fibre), 1.50mm [34] (30-029800-00)		DT012▲ (21-26853-20/0)	EH951 [8] (22-25605-00/0) EH952 (22-25605-02/0)
TU1M (HDY)	1124	4	72.00	Carburettor	40/54							

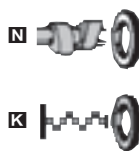
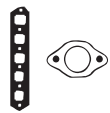

AC5700



AD5700, AD5710



BH950, BL620



BN580



BS810, BR490



JC135



JC702



JD551



JE189



JN596



JN658



JJ586











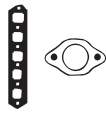

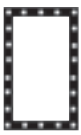















	JC135	JN596 (50-023671-00)	PA349 (33-102290-10) 22x16x2mm	HR300	NF678 35x50x8mm, ACM NF641 78x100x10mm, MVQ	HR564 [37] NF526 (x2) [2] NF334 (x2) [38] NF836 (x2) [38] HG108 [39] [40] HL442 [39] [41] NF735 [42] HG092 [43] [44] HG093 [43] [48] LV847 [45] LT832 [46]		
HBS039 (22-15010B) M10x1.50x175mm (x10)	JD551 (x2) (31-029803-00) JC702 (x2) (31-029804-00) JE189 (31-029805-00)	JN658 (50-026853-00)	JJ586 (31-029806-00) PB852 16x24x1.5mm PA349 (33-102290-10) 22x16x2mm	HR642	NF817 36x50x7mm, FPM (50-319112-00) NF870 42x66x6mm, FPM/ACM (50-319113-00) NF857 85x105x9mm, FPM/ACM (50-319478-00)	HL5011 [245] HR564 [37] NF836 [38] NF826 [38] PA850 [13] PA858 [13]		
HBS039 (22-15010B) M10x1.50x175mm (x10)	JD551 (x2) (31-029803-00) JC702 (x2) (31-029804-00) JE189 (31-029805-00)	JN658 (50-026853-00)	JJ586 (31-029806-00) PB852 16x24x1.5mm PA349 (33-102290-10) 22x16x2mm	HR642	NF817 36x50x7mm, FPM (50-319112-00) NF870 42x66x6mm, FPM/ACM (50-319113-00) NF857 85x105x9mm, FPM/ACM (50-319478-00)	HL5011 [245] HR564 [37] NA5205 [38] NA5204 [38] PA850 [13] PA858 [13]		
HBS039 (22-15010B) M10x1.50x175mm (x10)	JD551 (x2) (31-029803-00) JC702 (x2) (31-029804-00) JE189 (31-029805-00)	JN658 (50-026853-00)	JJ586 (31-029806-00) PB852 16x24x1.5mm PA349 (33-102290-10) 22x16x2mm	HR642	NF817 36x50x7mm, FPM (50-319112-00) NF870 42x66x6mm, FPM/ACM (50-319113-00) NF857 85x105x9mm, FPM/ACM (50-319478-00)	HL5011 [245] HR564 [37] NF836 [38] NF826 [38] PA850 [13] PA858 [13]		
HBS039 (22-15010B) M10x1.50x175mm (x10)	JD551 (x2) (31-029803-00) JC702 (31-029804-00) JE189 (31-029805-00)	JN658 (50-026853-00)	JJ586 (31-029806-00) PB852 16x24x1.5mm PA349 (33-102290-10) 22x16x2mm	HR642	NF817 36x50x7mm, FPM (50-319112-00) NF870 42x66x6mm, FPM/ACM (50-319113-00) NF857 85x105x9mm, FPM/ACM (50-319478-00)	HL5011 [245] HR564 [37] NA5205 [38] NA5204 [38] NF826 [38] PA850 [13] PA858 [13]		
HBS039 (22-15010B) M10x1.50x175mm (x10)	JD551 (x2) (31-029803-00) TU1M JD5828 HA5028 JC702 (x2) (31-029804-00) TU1M JE189 (31-029805-00) TU1M	JN658 (50-026853-00)	JJ586 (31-029806-00) PB852 16x24x1.5mm PA349 (33-102290-10) 22x16x2mm	HR642	NF817 36x50x7mm, FPM (50-319112-00) NF870 42x66x6mm, FPM/ACM (50-319113-00) NF857 85x105x9mm, FPM/ACM (50-319478-00)	HL5011 [245] HR564 [37] NA5205 [38] NA5204 [38] PA850 [13]		
HBS039 (22-15010B) M10x1.50x175mm (x10)	JD551 (x2) (31-029803-00) JC702 (x2) (31-029804-00) JE189 (31-029805-00)	JN658 (50-026853-00)	JJ586 (31-029806-00) PB852 16x24x1.5mm PA349 (33-102290-10) 22x16x2mm	HR642	NF817 36x50x7mm, FPM (50-319112-00) NF870 42x66x6mm, FPM/ACM (50-319113-00) NF857 85x105x9mm, FPM/ACM (50-319478-00)	HL5011 [245] HR564 [37] NA5205 [38] NA5204 [38] PA850 [13] PA858 [13]		



KW/PS



106 1.3L					10/93 → 04/96	12		DY130▲ (21-26853-21/0)	EH951 [8] (22-25605-00/0) EH952 (22-25605-02/0)
TU2J2 (MFZ)	1294	4	75.00	MPi		72/98			
106 1.4L					09/91 → 04/96	13	AY110 (Fibre) TU3MC (iron / fonte) AD5700 (Fibre), 1.25mm (30-026851-00) TU3M AD5710 (Fibre), 1.50mm [34] (30-029799-00) TU3M BY170 (Fibre), 1.50mm [34] TU3MC (iron / fonte)	DT010 (21-26851-20/0) TU3M DT012▲ (21-26853-20/0) TU3M DY130▲ (21-26853-21/0) TU3MC (iron / fonte)	EH951 [8] (22-25605-00/0) TU3M EH952 (22-25605-02/0) TU3M EY130 (22-28758-00/0) TU3MC (iron / fonte)
TU3MC (KDX/KDY)	1360	4	75.00	SPi		55-56/ 75-76			
TU3M (KDY)	1360	4	75.00	Carburettor		55-58/ 75-79			
106 1.4L					09/91 → 04/96	14	AY110 (Fibre) (iron / fonte) AD5700 (Fibre), 1.25mm (30-026851-00) TU3J2 AD5710 (Fibre), 1.50mm [34] (30-029799-00) TU3J2 BY170 (Fibre), 1.50mm [34] (iron / fonte)	DT010 (21-26851-20/0) TU3J2 DT012▲ (21-26853-20/0) TU3J2 DY130▲ (21-26853-21/0) (iron / fonte)	EH951 [8] (22-25605-00/0) TU3J2 EH952 (22-25605-02/0) TU3J2 EY130 (22-28758-00/0) (iron / fonte)
TU3J2 (KFZ)	1360	4	75.00	MPi		69/93			
106 1.4L D Diesel					09/92 → 04/96	15	BS730 (Steel Elastomer), 1.80mm (30-026845-20) BY120 (Fibre), 1.80mm (30-029802-00)	DS731▲ (21-26844-21/0)	EH951 [8] (22-25605-00/0) EH952 (22-25605-02/0)
TUD3 (K9A/K9B/K9Y)	1360	4	75.00	SOHC		39/53			
106 1.4L i					05/96 →	16	AD5700 (Fibre), 1.25mm (30-026851-00) AD5710 (Fibre), 1.50mm [34] (30-029799-00)	DT012▲ (21-26853-20/0)	EH951 [8] (22-25605-00/0)
TU3JP (KFW/ K6D)/TU3JP (KFX)	1360	4	75.00	MPi, SOHC		55/75			
106 1.5L D Diesel					06/94 → 04/96	17	BY150 (Fibre), 1.75mm (30-028755-00)	DY150▲ (21-28757-20/0)	
TUD5 (VJX)	1527	4				43/58			
TUD5 (VJY/VJZ)	1527	4	77.00			40/54			
	1527	4	77.00			42/57			
106 1.6L					06/93 → 04/96	18	BY180 (Fibre), 1.37mm (30-028756-00) AY120 (Fibre), 1.57mm [34] (30-029801-00)	DY130▲ (21-26853-21/0)	EY130 (22-28758-00/0)
106 1.6L i					05/96 →				
TU5J2 (NFW)	1587	4	78.50	MPi		65/88			
TU5J2 (NFW/NFY)	1587	4	78.50	MPi, DOHC		65/88			
TU5JP (NFZ)	1587	4	78.50	MPi		65/88			
106 1.6L S16					05/96 →	19	AE5010 (MLS), 1.37mm (30-029786-00) AE5020 (MLS), 1.57mm (30-029787-00) AE5030 (MLS), 1.77mm	CE5010 (21-29786-20/0)	
TU5J4 (NFX)	1587	4	78.50	MPi		87/118			

						 		
HBS039 [22-15010B] M10x1.50x175mm (x10)	JC702 (x2) (31-029804-00) JE189 (31-029805-00)	JN658 (50-026853-00)	JJ586 (31-029806-00) ● PB852 16x24x1.5mm ● PA349 (33-102290-10) 22x16x2mm	HR642	NF817 36x50x7mm, FPM (50-319112-00) NF870 42x66x6mm, FPM/ACM (50-319113-00) NF857 85x105x9mm, FPM/ACM (50-319478-00)	HL5011 [245] HR564 [37] NF836 [38] NF826 [38] PA850 [13] PA858 [13]	 AD5700, AD5710  AE5010, AE5020, AE5030  AY120  BS730, BY120  BY150  BY170, BY180	
HBS039 [22-15010B] M10x1.50x175mm (x10)	JD551 (x2) (31-029803-00) JC702 (x2) (31-029804-00) JE189 (31-029805-00)	JN658 (50-026853-00)	JJ586 (31-029806-00) TU3M JJ587 TU3MC (iron / fonte) ● PB852 16x24x1.5mm ● PA349 (33-102290-10) 22x16x2mm	HR642	NF817 36x50x7mm, FPM (50-319112-00) NF870 42x66x6mm, FPM/ACM (50-319113-00) NF857 85x105x9mm, FPM/ACM (50-319478-00)	HL5011 [245] HR564 [37] NF836 [38] NF826 [38] PA850 [13] PA858 [13]	 JC702  JD538  JD551  JE189  JF067	
HBS082 [22-15001B] M10x1.50x185mm (x10)	JF067	JN758	JJ586 (31-029806-00) ● PB852 16x24x1.5mm ● PA349 (33-102290-10) 22x16x2mm	HR642	NF817 36x50x7mm, FPM (50-319112-00) NF870 42x66x6mm, FPM/ACM (50-319113-00) NF857 85x105x9mm, FPM/ACM (50-319478-00)	HL5011 [245] HR564 [37] NF836 [38] NF826 [38] PA850 [13] PA858 [13] PB259 [14]	 JN658  JN758  JP041	
HBS039 [22-15010B] M10x1.50x175mm (x10)	JD538 (x4) (31-029472-00) JD5828 HA5028 JC702 (x2) (31-029804-00) JE5072 (MLS)	JN658 (50-026853-00)	● PB852 16x24x1.5mm	HR642	NF817 36x50x7mm, FPM (50-319112-00) NF870 42x66x6mm, FPM/ACM (50-319113-00) NF857 85x105x9mm, FPM/ACM (50-319478-00)	HL5011 [245] HR564 [37] NA5205 [38] NA5204 [38] PA850 [13]	 JN658  JN758  JP041	
HBS113 [22-15015B] M11x1.50x185mm (x10)		JP041 (50-028757-00)	JJ587 ● PB907 14x21x2mm	HR642	NF817 36x50x7mm, FPM (50-319112-00) NF870 42x66x6mm, FPM/ACM (50-319113-00) NF857 85x105x9mm, FPM/ACM (50-319478-00)	HL5011 [245] NA5205 [38] NA5204 [38] PB259 [14]	 JJ586  JJ587	
HBS039 [22-15010B] M10x1.50x175mm (x10)	JD530 (x4) JC702 (x2) (31-029804-00) JE189 (31-029805-00)	JN658 (50-026853-00)	JJ587 ● PB852 16x24x1.5mm ● PA349 (33-102290-10) 22x16x2mm	HR642	NF817 36x50x7mm, FPM (50-319112-00) NF870 42x66x6mm, FPM/ACM (50-319113-00) NF857 85x105x9mm, FPM/ACM (50-319478-00)	HL5011 [245] NA5205 [38] NA5204 [38]	 JJ586  JJ587	
HBS254 [22-53009B] M10x1.50x122mm (x10)	JE5044 (31-030016-00) (MLS)	HR397 [57] 34-000410-00			NA5260 38x50x6mm NF870 42x66x6mm, FPM/ACM (50-319113-00) NF857 85x105x9mm, FPM/ACM (50-319478-00)	HL5038 [245] NA5205 [38] NA5204 [38]		







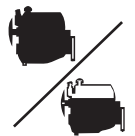



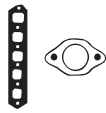

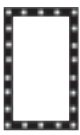

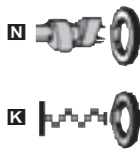













































































































PEUGEOT



KW/PS

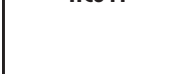

107 1.0L					06/05 →	20	AG9310 (MLS)	CG9310	EG9310
1KR (384 F)	998	3	71.00	Injection					
107 1.4L HDI Diesel					06/05 →	21	AD5130 (MLS), 1.25mm, 2 Notches, +3 Notches (30-029277-00) AD5140 (MLS), 1.30mm, 3 Notches, +3 Notches (30-029278-00) AD5150 (MLS), 1.35mm, 1 Notch, +3 Notches (30-029279-00) AD5160 (MLS), 1.40mm, +3 Notches, 4 Notches (30-029280-00) AD5170 (MLS), 1.45mm, +3 Notches, 5 Notches (30-029281-00)	CD5130▲ (21-29277-00/0)	ED5130
	1398	4				40/54			
205 1.0L					02/83 → 10/87	22	BF290 (Fibre), 1.20mm [33] (30-023670-10) →11/85 BN570 (Fibre), 1.20mm [35] (30-026351-10) 11/85 →	DN571▲	EH950 [36]
XV8 (108C)	954	4	70.00	Carburettor		33/45			
205 1.0L					10/87 → 09/98	23	BS810 (Fibre), 1.30mm (30-026850-00) BR490 (Fibre), 1.50mm [34] (30-029800-00)	DS810 (21-26850-20/0) DT012▲ (21-26853-20/0)	EH951 [8] (22-25605-00/0) EH952 (22-25605-02/0)
TU9 (C1A/C1B)	954	4	70.00	Carburettor		33/45			
205 1.1L					02/83 → 10/90	24	BH950 (Fibre), 1.20mm, 1 Notch [33] (30-025152-10) →11/85 BL620 (Fibre), 1.40mm [33] [34] →11/85 BN580 (Fibre), 1.20mm [35] (30-026021-10) 11/85 →	DN571▲	EH950 [36]
XW7 (109N) XW7 (109F)	1124 1124	4 4	72.00 72.00	Carburettor Carburettor		36/49 37/50			
205 1.1L					10/87 → 09/98	25	AD5700 (Fibre), 1.25mm (30-026851-00) AD5710 (Fibre), 1.50mm [34] (30-029799-00)	DT010 (21-26851-20/0) DT012▲ (21-26853-20/0)	EH951 [8] (22-25605-00/0) EH952 (22-25605-02/0)
TU1 (H1A/H1B/H3A) TU1M (HDZ)	1124 1124	4 4	72.00 72.00	Carburettor SPi		40/54 44/60			
205 1.2L					01/87 → 12/90	26	BF100 (Fibre), 1.30mm BG480 (Fibre), 1.80mm [34]	DF106▲■○ (21-21887-20/0) DF107▲■	EF102
F1	1118	4	74.00	Carburettor		46/62			
205 1.3L					02/84 → 10/87	27	BF170 (Fibre), 1.30mm (30-023495-10) BG490 (Fibre), 1.80mm [34]	DF106▲■○ (21-21887-20/0) DF107▲■	EF102
G1 / G2	1294	4	76.70	Carburettor		47-48/ 64-65			
205 1.3L Rallye					10/87 → 10/90	28	AD5700 (Fibre), 1.25mm (30-026851-00) AD5710 (Fibre), 1.50mm [34] (30-029799-00)	DT013▲ (21-26853-22/0)	EH951 [8] (22-25605-00/0) EH952 (22-25605-02/0)
TU2.4	1294	4	75.00	Carburettor		70/95			

								 AD5130, AD5140, AD5150, AD5160, AD5170	 JJ586
		JD5845  (NBR) JD5846  (MLS) JD5863  (Steel Elastomer)	JM7042 (ACM)			 NA5260 38x50x6mm		 AD5700, AD5710	
HBS359  (22-15018B) M11x1.50x150mm (x10)	HA5029   (24-35042-80/0) JD5829  (31-030265-00)		 KG5157 10x20x2mm				HL5033 [245] 	 BF100, BG480	
	JC135 	JN596 (50-023671-00)	 PA349 (33-102290-10) 22x16x2mm	HR300 	 NF678  35x50x8mm, ACM  NF641  78x100x10mm, MVQ		HR571 [37]  →Eng.5.114.184 HR564 [37]  Eng.5.114.185→ NF836 (x2) [38]  HG108 [39] [40]  HL442 [39] [41]  HG087 [43] [44]  LT832 [46]	 BF170, BG490	 BF290, BN570
HBS039  (22-15010B) M10x1.50x175mm (x10)	JD551  (x2) (31-029803-00) JC702  (x2) (31-029804-00)  JE189 (31-029805-00)	JN658 (50-026853-00)	JJ586 (31-029806-00)  PB852 16x24x1.5mm  PA349 (33-102290-10) 22x16x2mm	HR642 	 NF817 36x50x7mm, FPM (50-319112-00)  NF870  42x66x6mm, FPM/ACM (50-319113-00)  NF857  85x105x9mm, FPM/ACM (50-319478-00)		HL5011 [245]  HR564 [37]  NF836 [38]  NF826 [38]  PA850 [13] PA858 [13]	 BH950, BL620	 BN580
	JC135 	JN596 (50-023671-00)	 PA349 (33-102290-10) 22x16x2mm	HR300 	 NF678  35x50x8mm, ACM  NF641  78x100x10mm, MVQ		HR564 [37]  NF836 (x2) [38]  HG108 [39] [40]  HL442 [39] [41]  HG087 [43] [44]  HG104 [43] [48]  LT832 [46]	 BS810, BR490	 JB836
HBS039  (22-15010B) M10x1.50x175mm (x10)	JD551  (x2) (31-029803-00) JC702  (x2) (31-029804-00)  JE189 (31-029805-00)	JN658 (50-026853-00)	JJ586 (31-029806-00)  PB852 16x24x1.5mm  PA349 (33-102290-10) 22x16x2mm	HR642 	 NF817 36x50x7mm, FPM (50-319112-00)  NF870  42x66x6mm, FPM/ACM (50-319113-00)  NF857  85x105x9mm, FPM/ACM (50-319478-00)		HL5011 [245]  HR564 [37]  NF836 [38]  NF826 [38]  PA850 [13] PA858 [13]	 JB837	 JC135
	JB836  JB837  (31-021888-10)	JN238 (31-021887-00)	HC341   KG5290 20.4x27x3mm		 NF694  40x58x8mm, ACM  NF692  71x88x8mm, MVQ		NF836 (x2) [38] 	 JC702	 JD551
HBS039  (22-15010B) M10x1.50x175mm (x10)	JB836  JB837  (31-021888-10)	JN238 (31-021887-00)	HC341   KG5290 20.4x27x3mm		 NF694  40x58x8mm, ACM  NF692  71x88x8mm, MVQ		NF836 (x2) [38] 	 JN238	 JN596
HBS039  (22-15010B) M10x1.50x175mm (x10)	JC702  (x2) (31-029804-00)  JE189 (31-029805-00)	JN658 (50-026853-00)	JJ586 (31-029806-00)  PB852 16x24x1.5mm	HR569  24-30667-00/0	 NF817 36x50x7mm, FPM (50-319112-00)  NF870  42x66x6mm, FPM/ACM (50-319113-00)  NF857  85x105x9mm, FPM/ACM (50-319478-00)		HL5011 [245]  HR564 [37]  NF836 [38]  NF826 [38]  PA850 [13] PA858 [13]	 JN658	 HC341











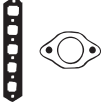

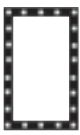

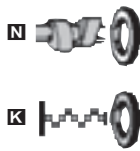



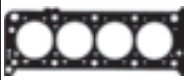



PEUGEOT



KWPS



205 1.4L						01/87 → 05/89	29	BN580 (Fibre), 1.20mm [35] (30-026021-10)	DN582▲	EH950 [36]			
205 Convertible 1.4L CJ						03/88 → 05/89							
205 Convertible 1.4L CT						04/86 → 12/88							
XY7 (150D)/XY7 (150G)	1360	4	75.00	Carburettor	44/60								
XY6B (150)	1360	4	75.00	Carburettor	53/72								
XY8 (150H)	1360	4	75.00	Carburettor	58/79								
XY8 (150B)	1360	4	75.00	Carburettor	58-59/ 79-80								
205 1.4L						02/83 → 10/87	30	BH950 (Fibre), 1.20mm, 1 Notch [33] (30-025152-10) →11/85 BL620 (Fibre), 1.40mm [33][34] →11/85 BN580 (Fibre), 1.20mm [35] (30-026021-10) 11/85→	DN582▲	EH950 [36]			
XY7 (150D)/XY7 (150G)	1360	4	75.00	Carburettor	44/60								
XY6B (150)	1360	4	75.00	Carburettor	53/72								
XY8 (150H)	1360	4	75.00	Carburettor	58/79								
205 1.4L						08/87 → 09/93	31	AD5700 (Fibre), 1.25mm (30-026851-00) AD5710 (Fibre), 1.50mm [34] (30-029799-00)	DT010 (21-26851-20/0) DT012▲ (21-26853-20/0)	EH951 [8] (22-25605-00/0) EH952 (22-25605-02/0)			
205 Convertible 1.4L CJ						01/89 → 12/94							
TU3CP (KAY)	1360	4	75.00	Carburettor	44/60								
TU3F2 (K1D)	1360	4	75.00	Carburettor	49/67								
TU3M (KDZ)	1360	4	75.00	SPi	55/75								
TU3M (KDY)	1360	4	75.00	Carburettor	55-58/ 75-79								
205 1.4L						07/88 → 09/98	32	AD5700 (Fibre), 1.25mm (30-026851-00) AD5710 (Fibre), 1.50mm [34] (30-029799-00)	DT010 (21-26851-20/0) TU3M DT012▲ (21-26853-20/0)	EH951 [8] (22-25605-00/0) EH952 (22-25605-02/0) TU3M			
TU3JP (KFX)	1360	4	75.00	MPi, SOHC	55/75								
TU3M (KDZ)	1360	4	75.00	SPi	55/75								
TU3M (KDY)	1360	4	75.00	Carburettor	55-58/ 75-79								
205 1.4L						06/87 → 12/89	33	BF170 (Fibre), 1.30mm (30-023495-10) BG490 (Fibre), 1.80mm [34]	DF106▲■○ (21-21887-20/0) DF107▲■	EF102			
	1442	4			63/86								
205 1.4L i						01/91 →	34	BY130 (Fibre), 1.28mm (30-029099-00) BY170 (Fibre), 1.50mm [34]	DY130▲ (21-26853-21/0)	EY130 (22-28758-00/0)			
TU3 F (Cast Iron Block)/ TU3 F2 (Cast Iron Block)/ TU3 F2C (Cast Iron Block)/ TU3 FJ2 (Cast Iron Block)/ TU3 FM (Cast Iron Block)	1360	4	75.00	SPi									
205 1.5L						02/84 → 10/87	35	BF170 (Fibre), 1.30mm (30-023495-10) BG490 (Fibre), 1.80mm [34]	DF106▲■○ (21-21887-20/0) DF107▲■	EF102			
	1442	4			63/86								

								
HBS039 ® (22-15010B) M10x1.50x175mm (x10)	JC135 ■	JN596 (50-023671-00)	● PA349 (33-102290-10) 22x16x2mm	HR300 ■	☒ NF678 ■ 35x50x8mm, ACM ☒ NF641 ■ 78x100x10mm, MVQ	HR564 [37]■ NF836 (x2) [38]■ HG108 [39] [40]■ HL442 [39] [41]■ HG092 [43] [44]■ HG093 [43] [48]■ LT832 [46]		 AD5700, AD5710  BF170, BG490  BH950, BL620  BN580  BY130  BY170  JB836  JB837  JC135  JC702  JD538  JD551  JE189  JN238  JN596  JN658  HC341
	JC135 ■	JN596 (50-023671-00)	● PA349 (33-102290-10) 22x16x2mm	HR300 ■	☒ NF678 ■ 35x50x8mm, ACM ☒ NF641 ■ 78x100x10mm, MVQ	HR564 [37]■ NF836 (x2) [38]■ HG108 [39] [40]■ HL442 [39] [41]■ HG092 [43] [44]■ HG093 [43] [48]■ LT832 [46]		
HBS039 ® (22-15010B) M10x1.50x175mm (x10)	JD551 ■ (x2) (31-029803-00) JC702 ■ (x2) (31-029804-00) ⊙ JE189 (31-029805-00)	JN658 (50-026853-00)	JJ586 (31-029806-00) ● PB852 16x24x1.5mm ● PA349 (33-102290-10) 22x16x2mm	HR642 ■	☒ NF817 36x50x7mm, FPM (50-319112-00) ☒ NF870 ■ 42x66x6mm, FPM/ACM (50-319113-00) ☒ NF857 ■ 85x105x9mm, FPM/ACM (50-319478-00)	HL5011 [245]■ HR564 [37]■ NF836 [38]■ →-06/99 NF826 [38]■ →-06/99 PA850 [13] PA858 [13]		
HBS039 ® (22-15010B) M10x1.50x175mm (x10)	JD538 ■ (x4) (31-029472-00) TU3JP JD551 ■ (x2) (31-029803-00) TU3M HA5028 ■ ■ JC702 ■ (x2) (31-029804-00) ⊙ JE189 (31-029805-00) TU3M ⊙ JE5072 (MLS)	JN658 (50-026853-00)	JJ586 (31-029806-00) TU3M ● PB852 16x24x1.5mm ● PA349 (33-102290-10) 22x16x2mm	HR642 ■	☒ NF817 36x50x7mm, FPM (50-319112-00) ☒ NF870 ■ 42x66x6mm, FPM/ACM (50-319113-00) ☒ NF857 ■ 85x105x9mm, FPM/ACM (50-319478-00)	HL5011 [245]■ HR564 [37]■ NF836 [38]■ NF826 [38]■ PA850 [13] PA858 [13]		
HBS039 ® (22-15010B) M10x1.50x175mm (x10)	JB836 ■ JB837 ■ (31-021888-10)	JN238 (31-021887-00)	HC341 ■ ● PA349 (33-102290-10) 22x16x2mm	HR569 ■ 24-30667-00/0	☒ NF694 ■ 40x58x8mm, ACM ☒ NF692 ■ 71x88x8mm, MVQ	NF836 (x2) [38]■		
HBS039 ® (22-15010B) M10x1.50x175mm (x10)	JC702 ■ (x2) (31-029804-00) ⊙ JE189 (31-029805-00)	JN658 (50-026853-00)	JJ587 ● PB852 16x24x1.5mm	HR642 ■	☒ NF817 36x50x7mm, FPM (50-319112-00) ☒ NF870 ■ 42x66x6mm, FPM/ACM (50-319113-00) ☒ NF857 ■ 85x105x9mm, FPM/ACM (50-319478-00)	HL5011 [245]■ HR564 [37]■ NA5205 [38]■ NF836 [38]■ NA5204 [38]■ NF826 [38]■		
HBS039 ® (22-15010B) M10x1.50x175mm (x10)	JB836 ■ JB837 ■ (31-021888-10)	JN238 (31-021887-00)	HC341 ■ ● PA349 (33-102290-10) 22x16x2mm	HR569 ■ 24-30667-00/0	☒ NF694 ■ 40x58x8mm, ACM ☒ NF692 ■ 71x88x8mm, MVQ	NF836 (x2) [38]■		



KW/PS

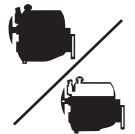

205 1.6L	08/86 → 09/98	36
205 1.6L Aut.	05/90 → 09/98	
205 1.6L GTI	12/84 → 12/89	
205 Aut.	10/87 → 09/98	
205 Convertible 1.6L CJ	08/92 → 12/94	
205 Convertible 1.6L CTI	04/86 → 10/90	
205 GTI	10/87 → 12/89	
205 GTX	01/87 → 10/91	

XU51C (B1A/B1C/B1E)	1580	4		83.00	Carburettor	58/79 85/116 53-55/ 72-75
XU5CP (BAZ)	1580	4		83.00	Carburettor	54-55/ 74-75
XU51C (B1A/B1C)	1580	4		83.00	Carburettor	55/75
XU5M3Z (BDY)	1580	4		83.00	Carburettor	65-66/ 88-90
XU5M2Z (BDY)	1580	4		83.00	Carburettor	65-71/ 88-97
XU5J (180)/XU5J (180A)	1580	4		83.00	MPi	76/103
	1592	4				69/94

BL650 (Fibre), 1.20mm (30-026859-10)
BR510 (Fibre), 1.44mm [34] (30-026858-10)

DN590▲ (21-25204-21/0)

EL650 (22-25198-00/0)
GL650

205 1.7L D Diesel	08/83 → 09/98	37
205 Van 1.7L D Diesel	03/94 →	

XUD7 (161A)	1769	4		80.00		44/60
-------------	------	---	--	-------	--	-------

BX830 (Fibre), 1.36mm, 1 Notch (30-028484-00) ☞ 0.56 → 0.67mm
BX840 (Fibre), 1.40mm, 2 Notches (30-028485-00) ☞ 0.68 → 0.71mm
BX850 (Fibre), 1.44mm, 3 Notches (30-028486-00) ☞ 0.72 → 0.75mm
BX860 (Fibre), 1.48mm, 4 Notches (30-028487-00) ☞ 0.76 → 0.79mm
BX870 (Fibre), 1.52mm, 5 Notches (30-028488-00) ☞ 0.80 → 0.83mm

DJ720▲ (21-25202-22/0)

EL890 (22-25198-01/0)
GJ720▲ (20-25202-02/0)











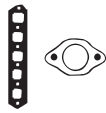

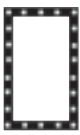





























205 1.7L TD Diesel	01/90 → 09/98	38
---------------------------	---------------	-----------

XUD7TE (A8B)	1769	4		80.00		57/78
--------------	------	---	--	-------	--	-------

BR780 (Fibre), 1.65mm, 2 Notches ☞ 0.65 → 0.77mm
BR790 (Fibre), 1.80mm, 3 Notches (30-026855-10) ☞ 0.77 → 0.82mm

DJ720▲ (21-25202-22/0)

EL890 (22-25198-01/0)
GJ720▲ (20-25202-02/0)







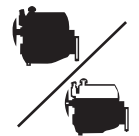



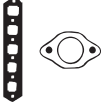

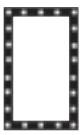

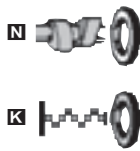

















































































								 BL650
HBS038  (22-15003B) M11x1.50x175mm (x10) HBS083  (22-15002B) M11x1.50x168mm (x10)	JC750  JC415  (x4) (31-025205-20)	JN547 (50-025204-10)	JJ283 [6] (31-025198-10) PA349 (33-102290-10) 22x16x2mm PB907 14x21x2mm	HR569  24-30667-00/0	NF817  36x50x7mm, FPM (50-319112-00) NA5191  42x62x7mm, PTFE (50-319500-00) NA5192  90x110x7mm, PTFE (50-319501-00)	HL5019 [245]  HR566 [37]  NF836 [38]  NF826 [38]  KA611 [13] LC292 (x2) [14]	 BR780, BR790  BX830, BX840, BX850, BX860, BX870  JC415  JC423  JC750  JC759  JC991  JN544  JN547  JJ283	
HBS084  (22-15005B) M12x1.50x123mm (x10)	JC759 [60] (31-028417-00) (Steel) JC423  (x2) (31-025199-10)	JN544 (50-025202-00)	JJ283 [6] (31-025198-10) PA349 (33-102290-10) 22x16x2mm PB907 14x21x2mm	HR569  24-30667-00/0	NF841  35x50x8mm, FPM (50-319310-00) NA5191  42x62x7mm, PTFE (50-319500-00) NA5192  90x110x7mm, PTFE (50-319501-00)	HL5010 [245]  NF836 [38]  NF826 [38]  KA611 [13]		
HBS084  (22-15005B) M12x1.50x123mm (x10)	JC759 [60] (31-028417-00) (Steel) →12/90 JC991 (31-028595-00) 01/91 →	JN544 (50-025202-00)	JJ283 [6] (31-025198-10) PA349 (33-102290-10) 22x16x2mm PB907 14x21x2mm	HR569  24-30667-00/0	NA5191  42x62x7mm, PTFE (50-319500-00)	NF836 [38]  NF826 [38]  KA611 [13]		



KW/PS



205 1.9L D Diesel				10/87 → 09/98		39	BX880 (Fibre), 1.36mm, 1 Notch (30-028475-00) -0.56 → 0.67mm BX890 (Fibre), 1.40mm, 2 Notches (30-028476-00) -0.68 → 0.71mm BX900 (Fibre), 1.44mm, 3 Notches (30-028477-00) -0.72 → 0.75mm BX910 (Fibre), 1.48mm, 4 Notches (30-028478-00) -0.76 → 0.79mm BX920 (Fibre), 1.52mm, 5 Notches (30-028479-00) -0.80 → 0.83mm	DJ720▲ (21-25202-22/0)	EL890 (22-25198-01/0) GJ720▲ (20-25202-02/0)
XUD9 (DIZ/D9A/162)	1905	4	83.00		47/64				
205 1.9L GTI				10/86 → 09/98		40	BL650 (Fibre), 1.20mm (30-026859-10) BR510 (Fibre), 1.44mm [34] (30-026858-10)	DN590▲ (21-25204-21/0)	EL650 (22-25198-00/0) GL650
205 Convertible 1.9L CTI				10/87 → 12/94					
XU92C (D2A)	1905	4	83.00	Carburettor	75/102				
XU911 (DFZ)	1905	4	83.00	MPi	90/122				
XU9JA (D6B)	1905	4	83.00	MPi, SOHC	94/128				
XU9JA (D6B)	1905	4	83.00	MPi, SOHC	94-96/ 128- 131				
205 1.9L GTI				10/87 → 10/94		41	BL650 (Fibre), 1.20mm (30-026859-10) BR510 (Fibre), 1.44mm [34] (30-026858-10)	DN590▲ (21-25204-21/0)	EL650 (22-25198-00/0) GL650
XU9JAZ (DKZ)	1905	4	83.00	MPi	90/122				
206 1.1L				07/02 →		42	AC5700 (Fibre), 1.26mm (30-029572-00)	CC5700 (21-29572-20/0)	EC5700
206 1.1L i				09/98 →					
TU1JP (HFZ)/TU1JP (HFZ)	1124	4	72.00	MPi	44/60				
206 1.4L				07/02 →		43	AD5700 (Fibre), 1.25mm (30-026851-00) AD5710 (Fibre), 1.50mm [34] (30-029799-00)	DT012▲ (21-26853-20/0)	EH951 [8] (22-25605-00/0)
206 1.4L i				09/98 →					
TU3JP (KFW/K6D)/TU3JP (KFX)	1360	4	75.00	MPi, SOHC	55/75				
206 1.4L 16V				10/03 →		44	AG9030 (Fibre), 1.4mm (30-030263-00)	CG9030	EG9030
KFU (ET3J4)	1360	4	75.00	Carburettor	65/88				
206 1.4L HDI Diesel				07/02 →		45	AD5130 (MLS), 1.25mm, 2 Notches, +3 Notches (30-029277-00) AD5140 (MLS), 1.30mm, 3 Notches, +3 Notches (30-029278-00) AD5150 (MLS), 1.35mm, 1 Notch, +3 Notches (30-029279-00) AD5160 (MLS), 1.40mm, +3 Notches, 4 Notches (30-029280-00) AD5170 (MLS), 1.45mm, +3 Notches, 5 Notches (30-029281-00)	CD5130▲ (21-29277-00/0)	ED5130
206 1.4L HDI eco 70 Diesel				09/01 →					
DV4TD (8HZ)	1398	4	73.70	Direct Injection	50/68				
DV4TD (8HX)	1398	4	73.70	Common Rail	52/71				

								
HBS084  [22-15005B] M12x1.50x123mm (x10)	JC423  (x2) [31-025199-10]	JN544 [50-025202-00]	JJ283 [6] [31-025198-10] PA349 [33-102290-10] 22x16x2mm PB907 14x21x2mm	HR569  24-30667-00/0	NF841 35x50x8mm, FPM [50-319310-00] →12/93 NB959 35x50x7mm, FPM [50-306644-50] 01/94→ NA5191  42x62x7mm, PTFE [50-319500-00] NA5192  90x110x7mm, PTFE [50-319501-00]	HL5010 [245]  HL5012 [245]  NF836 [38]  NF826 [38]  KA611 [13]	 AC5700  AD5130, AD5140, AD5150, AD5160, AD5170  AD5700, AD5710  BL650  BX880, BX890, BX900, BX910, BX920	
HBS038  [22-15003B] M11x1.50x175mm (x10) HBS083  [22-15002B] M11x1.50x168mm (x10)	JC750  JC415  (x4) [31-025205-20]	JN547 [50-025204-10]	JJ283 [6] [31-025198-10] PA349 [33-102290-10] 22x16x2mm PB907 14x21x2mm	HR569  24-30667-00/0	NF817 36x50x7mm, FPM [50-319112-00] NA5191  42x62x7mm, PTFE [50-319500-00] NA5192  90x110x7mm, PTFE [50-319501-00]	HL5019 [245]  HR566 [37]  NF836 [38]  NF826 [38]  KA611 [13] LC292 (x2) [14]	 JC415  JC423  JC702  JC750  JD538	
HBS038  [22-15003B] M11x1.50x175mm (x10) HBS083  [22-15002B] M11x1.50x168mm (x10)	JC415  (x4) [31-025205-20]	JN547 [50-025204-10]	JJ283 [6] [31-025198-10] PA349 [33-102290-10] 22x16x2mm PB907 14x21x2mm	HR569  24-30667-00/0	NF817 36x50x7mm, FPM [50-319112-00] NA5191  42x62x7mm, PTFE [50-319500-00] NA5192  90x110x7mm, PTFE [50-319501-00]	HL5019 [245]  HR566 [37]  NF836 [38]  NF826 [38]  KA611 [13] LC292 (x2) [14]	 JD538  JN544  JN547  JN658  JJ283	
HBS039  [22-15010B] M10x1.50x175mm (x10)	JD538  [31-029472-00] JD5828  HA5028   	JN658 [50-026853-00]	PB852 16x24x1.5mm PA349 [33-102290-10] 22x16x2mm	HR642 	NF817 36x50x7mm, FPM [50-319112-00] NF870  42x66x6mm, FPM/ACM [50-319113-00] NF857  85x105x9mm, FPM/ACM [50-319478-00]	HL5011 [245]  HR564 [37]  NA5205 [38]  NA5204 [38]  PA850 [13]	 JN544  JN547  JN658  JJ283	
HBS039  [22-15010B] M10x1.50x175mm (x10)	JD538  (x4) [31-029472-00] JD5828  HA5028    JC702  (x2) [31-029804-00]  JE5072 (MLS)	JN658 [50-026853-00]	PB852 16x24x1.5mm	HR642 	NF817 36x50x7mm, FPM [50-319112-00] NF870  42x66x6mm, FPM/ACM [50-319113-00] NF857  85x105x9mm, FPM/ACM [50-319478-00]	HL5011 [245]  HR564 [37]  NA5205 [38]  NA5204 [38]  PA850 [13]	 JN544  JN547  JN658  JJ283	
	JD5882  (FPM) JD5831   JE5072 (MLS)	JM7051 JM7052						
HBS359  [22-15018B] M11x1.50x150mm (x10)	HA5029    [24-35042-80/0] JD5829  [31-030265-00]		KG5157 10x20x2mm		NA5258 27x47x7mm NA5259  40x55x6.4mm	HL5033 [245] 		











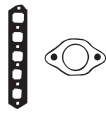

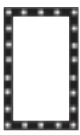

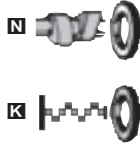

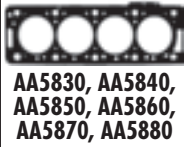









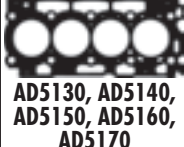

















































PEUGEOT



KW/PS













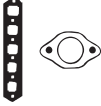

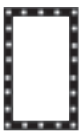

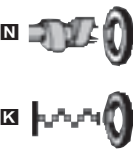

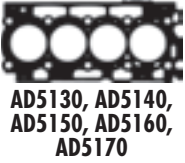











































































206 1.6L 16V					09/00 →	46	AD5180 (MLS), 0.62mm (30-029785-00)		CD5180 (21-29785-20/0)	ED5180
TU5JP4 (NFU/N6A)	1587	4	78.50	MPi		80/109				
206 1.6L HDI FAP 110 Diesel					05/04 →	47	AD5130 (MLS), 1.25mm, 2 Notches, +3 Notches (30-029277-00) AD5140 (MLS), 1.30mm, 3 Notches, +3 Notches (30-029278-00) AD5150 (MLS), 1.35mm, 1 Notch, +3 Notches (30-029279-00) AD5160 (MLS), 1.40mm, +3 Notches, 4 Notches (30-029280-00) AD5170 (MLS), 1.45mm, +3 Notches, 5 Notches (30-029281-00)		CD5140▲ (21-29278-00/0)	
DV6TED4 (9HY)/ DV6TED4 (9HZ)	1560	4	75.00	HDI, DOHC		80/109				
206 1.6L i					09/98 →12/00	48	BY180 (Fibre), 1.37mm (30-028756-00) AY120 (Fibre), 1.57mm [34] (30-029801-00)		DY130▲ (21-26853-21/0)	EY130 (22-28758-00/0)
TU5JP (NFZ)	1587	4	78.50	MPi		65/88				
206 1.9L D Diesel					09/98 →11/01	49	AA5830 (Steel Elastomer), 1.26mm, 1 Hole (30-029190-00) ☞0.51→0.54mm AA5840 (Steel Elastomer), 1.30mm, 2 Holes (30-029191-00) ☞0.55→0.58mm AA5850 (Steel Elastomer), 1.34mm, 3 Holes (30-029192-00) ☞0.59→0.62mm AA5860 (Steel Elastomer), 1.38mm, 4 Holes (30-029193-00) ☞0.63→0.66mm AA5870 (Steel Elastomer), 1.42mm, 5 Holes (30-029194-00) ☞0.67→0.70mm AA5880 (Steel Elastomer), 1.46mm, 6 Holes (30-029195-00) ☞0.71→0.75mm		CA5830▲ (21-29482-20/0)	EA5830
DW8 (WJZ)	1868	4	82.20	SOHC		51/69				
206 2.0L 16V					07/02 →	50	AD5300 (MLS)		CD5300	ED5300
206 2.0L RC					07/03 →					
206 2.0L S16					04/99 →10/00					
EW10J4 (RFR)	1997	4	85.00	Injection, DOHC			99/135			
EW10J4 (RFN)	1997	4	85.00	MPi, DOHC		100/136				
EW10J4S (RFK)	1997	4	85.00	Injection, DOHC		130/177				
206 2.0L HDI Diesel					07/02 →	51	AC5011 (MLS), 1.30mm, 1 Hole ☞0.47→0.605mm		CC5010▲ (21-29484-20/0)	EA5830
206 2.0L HDI 90 Diesel					12/99 →		AC5031 (MLS), 1.40mm, 3 Holes (30-029479-10) ☞0.655→0.705mm AC5051 (MLS), 1.50mm, 5 Holes (30-029481-10) ☞0.755→0.83mm			
DW10TD (RHY)	1997	4	85.00	Common Rail		63/86				
207 1.4L 16V					02/06 →	52	AG9030 (Fibre), 1.4mm (30-030263-00)		CG9030	EG9030
KFU (ET3J4)	1360	4	75.00	Carburettor		65/88				

								 AA5830, AA5840, AA5850, AA5860, AA5870, AA5880
HBS254  (22-53009B) M10x1.50x122mm (x10)	HA5032  (24-35043-10/0) JD5831   (MLS)	JM7035 (50-030267-00)	JH5107 (ACM) ● PB852 16x24x1.5mm ● PA349 (33-102290-10) 22x16x2mm		 NA5260 38x50x6mm  NF870 42x66x6mm, FPM/ACM (50-319113-00)  NF857 85x105x9mm, FPM/ACM (50-319478-00)	HL5038 [245]  NA5205 [38]  NA5204 [38] 	 AD5130, AD5140, AD5150, AD5160, AD5170	
HBS359  (22-15018B) M11x1.50x150mm (x10)	JD5830  (50-030266-00) HA5031   (24-35043-00/0) HA5030   (24-35042-90/0) JD5829  (31-030265-00)	JM7034 (50-030264-00)			 NA5258 27x47x7mm  NA5259 40x55x6.4mm	HL5033 [245] 	 AD5180  AY120  BY180	
HBS039  (22-15010B) M10x1.50x175mm (x10)	JD530  (x4) JC702  (x2) (31-029804-00)  (31-029805-00)	JN658 (50-026853-00)	JJ587 ● PB852 16x24x1.5mm ● PA349 (33-102290-10) 22x16x2mm	HR642 	 NF817 36x50x7mm, FPM (50-319112-00)  NF870 42x66x6mm, FPM/ACM (50-319113-00)  NF857 85x105x9mm, FPM/ACM (50-319478-00)	HL5011 [245]  NA5205 [38]  NA5204 [38] 	 JC702  JE189	
HBS084  (22-15005B) M12x1.50x123mm (x10) → Eng.08469 HBS245  (22-53008B) M12x1.50x125mm (x10) Eng.08470 →	HA5008  JD5192  (x2)	JM5088  JM5089 	● KG5157 10x20x2mm ● PB907 14x21x2mm	HR569  24-30667-00/0	 NB959 35x50x7mm, FPM (50-306644-50)  NA5191 42x62x7mm, PTFE (50-319500-00)  NA5192 90x110x7mm, PTFE (50-319501-00)	HL5012 [245]  NA5205 [38]  NA5204 [38] 	 JN658  JJ587	
HBS259  (22-53010B) M11x1.50x144.5mm (x10)	JD5833 	JM5283  JM5139 	● PB907 14x21x2mm		 NA5256 40x55x6.5mm			
HBS261  (22-53014B) M12x1.50x131mm (x10)	JD5191  JD5190 	JM5087	● KG5157 10x20x2mm ● PB907 14x21x2mm	HR5046  (x2)	 NA5035 27x47x7mm, FPM (50-319474-00)  NA5191 42x62x7mm, PTFE (50-319500-00)  NA5192 90x110x7mm, PTFE (50-319501-00)	HL5016 [245]  NA5205 [38]  NA5204 [38] 		
	JD5882  (FPM) JD5831   (MLS)	JM7051 JM7052						



KW/PS













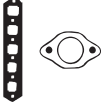

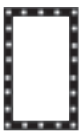

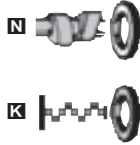

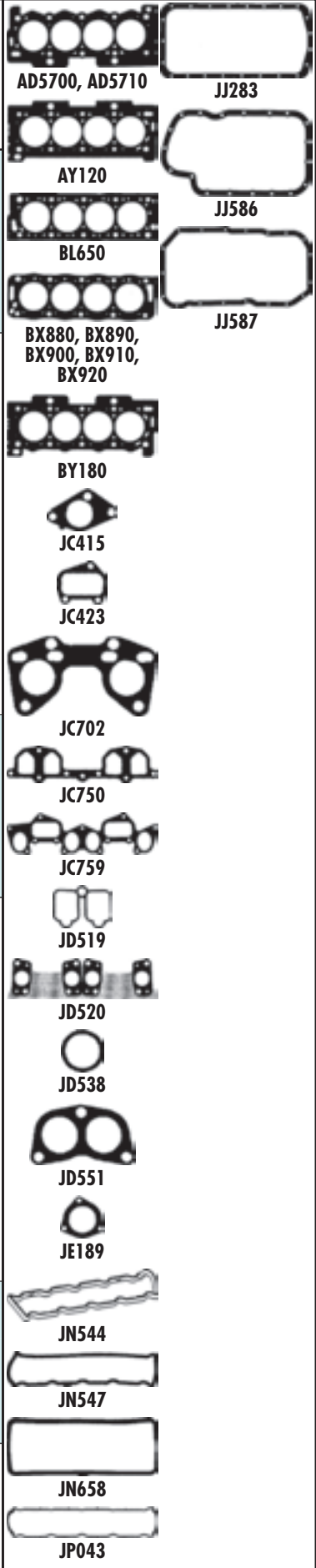

























































							 <p>AD5130, AD5140, AD5150, AD5160, AD5170</p>  <p>AD5180</p>  <p>BF570, BP760</p>  <p>BL650</p>  <p>JB875</p>  <p>JC415</p>  <p>JC750</p>  <p>JE145</p>  <p>JE647</p>  <p>JN547</p>  <p>JJ057</p>  <p>JJ283</p>
HBS359  (22-15018B) M11x1.50x150mm (x10)	HA5029   (24-35042-80/0) JD5829  (31-030265-00)		KG5157 10x20x2mm			HL5033 [245] 	
HBS254  (22-53009B) M10x1.50x122mm (x10)	HA5032   (24-35043-10/0) JD5831   JE5072 (MLS)	JM7035 (50-030267-00)	JH5107 (ACM) PB852 16x24x1.5mm PA349 (33-102290-10) 22x16x2mm		 NA5260 38x50x6mm  NF870  42x66x6mm, FPM/ACM (50-319113-00)  NF857  85x105x9mm, FPM/ACM (50-319478-00)	HL5038 [245]  NA5205 [38]  NA5204 [38] 	
HBS359  (22-15018B) M11x1.50x150mm (x10)	JD5830   (50-030266-00) HA5031    (24-35043-00/0) HA5030    (24-35042-90/0) JD5829  (31-030265-00)	JM7034 (50-030264-00)			 NA5258 27x47x7mm  NA5259  40x55x6.4mm	HL5033 [245] 	
	JB875   JE647 [47] (31-022193-10)		JJ057 PA349 (33-102290-10) 22x16x2mm	HR300 	 NF640  60.5x78x9mm, MVQ	HR573 [37]  Paper →Eng.9285506 NF528 (x2) [2]   NF539 (x2) [2]   NF836 (x2) [38]  KA525 [13] LV851 [51] HG088 [43]  LT832 [46]	
	JB875   JE145 [47]		JJ057 PA349 (33-102290-10) 22x16x2mm	HR300 	 NF640  60.5x78x9mm, MVQ	HR573 [37]  Paper →Eng.9285506 NF528 (x2) [2]   NF539 (x2) [2]   NF836 (x2) [38]  KA525 [13] LV851 [51] HG088 [43]  LT832 [46]	
HBS038  (22-15003B) M11x1.50x175mm (x10) HBS083  (22-15002B) M11x1.50x168mm (x10)	JC750  JC415  (x4) (31-025205-20)	JN547 (50-025204-10)	JJ283 [6] (31-025198-10) PA349 (33-102290-10) 22x16x2mm PB907 14x21x2mm	HR569  24-30667-00/0	 NF817 36x50x7mm, FPM (50-319112-00)  NA5191  42x62x7mm, PTFE (50-319500-00)  NA5192  90x110x7mm, PTFE (50-319501-00)	HL5019 [245]  HR566 [37]  NF528 (x2) [2]   NF539 (x2) [2]   NF836 [38]  NF826 [38]  KA611 [13] LC292 (x2) [14]	



KW/PS



305 1.9L				10/82 → 12/88		59	BL650 (Fibre), 1.20mm (30-026859-10) BR510 (Fibre), 1.44mm [34] (30-026858-10)	DN590▲ (21-25204-21/0)	EL650 (22-25198-00/0) GL650
XU92C	1905	4	83.00	Carburettor	75/102				
XU911 (DFZ)	1905	4	83.00	MPi	90/122				
305 1.9L D Diesel				10/82 → 12/88		60	BX880 (Fibre), 1.36mm, 1 Notch (30-028475-00) ☞0.56 → 0.67mm BX890 (Fibre), 1.40mm, 2 Notches (30-028476-00) ☞0.68 → 0.71mm BX900 (Fibre), 1.44mm, 3 Notches (30-028477-00) ☞0.72 → 0.75mm BX910 (Fibre), 1.48mm, 4 Notches (30-028478-00) ☞0.76 → 0.79mm BX920 (Fibre), 1.52mm, 5 Notches (30-028479-00) ☞0.80 → 0.83mm	DJ720▲ (21-25202-22/0)	EL890 (22-25198-01/0) GJ720▲ (20-25202-02/0)
XUD9 (D9A)	1905	4	83.00		47/64				
XUD9 (16Z)	1905	4	83.00		47-48/ 64-65				
306 1.1L				05/93 → 05/01		61	AD5700 (Fibre), 1.25mm (30-026851-00) AD5710 (Fibre), 1.50mm [34] (30-029799-00)	DT010 (21-26851-20/0) DT012▲ (21-26853-20/0)	EH951 [8] (22-25605-00/0) EH952 (22-25605-02/0)
TU1M (HDZ)	1124	4	72.00	SPi	44/60				
306 1.4L				05/93 → 04/02		62	AD5700 (Fibre), 1.25mm (30-026851-00) AD5710 (Fibre), 1.50mm [34] (30-029799-00)	DT010 (21-26851-20/0) TU3M DT012▲ (21-26853-20/0)	EH951 [8] (22-25605-00/0) EH952 (22-25605-02/0) TU3M
TU3JP (KFW/ K6D)/TU3JP (KFX)	1360	4	75.00	MPi, SOHC	55/75				
TU3MC (KDX/KDY)	1360	4	75.00	SPi	55-56/ 75-76				
306 1.6L				05/93 → 04/02		63	BY180 (Fibre), 1.37mm (30-028756-00) AY120 (Fibre), 1.57mm [34] (30-029801-00)	DY130▲ (21-26853-21/0)	EY130 (22-28758-00/0)
TU5JP (NFZ)	1587	4	78.50	MPi	65/88				
TU5JP (NFT)	1587	4	78.50	Injection	72/98				
306 1.6L SR				06/94 → 10/00					
306 Convertible 1.6L				04/96 → 04/02					
306 1.8L				05/93 → 04/02		64	BL650 (Fibre), 1.20mm (30-026859-10) BR510 (Fibre), 1.44mm [34] (30-026858-10)	CY130▲ (21-28759-20/0)	EL650 (22-25198-00/0)
XU7JP (LFZ)	1761	4	83.00	MPi	74/100				
306 1.8L ST				06/94 → 05/01					
306 Convertible 1.8L				03/94 → 04/02					

								
HBS038  (22-15003B) M11x1.50x175mm (x10) HBS083  (22-15002B) M11x1.50x168mm (x10)	JC750  JC415  (x4) (31-025205-20)	JN547 (50-025204-10)	JJ283 [6] (31-025198-10) PA349 (33-102290-10) 22x16x2mm PB907 14x21x2mm	HR569  24-30667-00/0	NF817 36x50x7mm, FPM (50-319112-00) NA5191  42x62x7mm, PTFE (50-319500-00) NA5192  90x110x7mm, PTFE (50-319501-00)	HL5019 [245]  HR566 [37]  NF836 [38]  NF826 [38]  KA611 [13] LC292 (x2) [14]	AD5700, AD5710 JJ283 AY120 BL650 BX880, BX890, BX900, BX910, BX920 BY180 JC415 JC423 JC702 JC750 JC759 JD519 JD520 JD538 JD551 JE189 JN544 JN547 JN658 JP043	
HBS084  (22-15005B) M12x1.50x123mm (x10)	JC759 [60] (31-028417-00) (Steel) JC423  (x2) (31-025199-10)	JN544 (50-025202-00)	JJ283 [6] (31-025198-10) PA349 (33-102290-10) 22x16x2mm PB907 14x21x2mm	HR569  24-30667-00/0	NF841 35x50x8mm, FPM (50-319310-00) →12/93 NB959 35x50x7mm, FPM (50-306644-50) 01/94 → NA5191  42x62x7mm, PTFE (50-319500-00) NA5192  90x110x7mm, PTFE (50-319501-00)	HL5010 [245]  HL5012 [245]  NF539 (x2) [2]  NF528 (x2) [2]  NF836 [38]  NF826 [38]  KA611 [13]	BX880, BX890, BX900, BX910, BX920 BY180 JC415 JC423 JC702 JC750 JC759 JD519 JD520 JD538 JD551 JE189 JN544 JN547 JN658 JP043	
HBS039  (22-15010B) M10x1.50x175mm (x10)	JD551  (x2) (31-029803-00) JC702  (x2) (31-029804-00) JE189  (31-029805-00)	JN658 (50-026853-00)	JJ586 (31-029806-00) PB852 16x24x1.5mm PA349 (33-102290-10) 22x16x2mm	HR642 	NF817 36x50x7mm, FPM (50-319112-00) NF870  42x66x6mm, FPM/ACM (50-319113-00) NF857  85x105x9mm, FPM/ACM (50-319478-00)	HL5011 [245]  HR564 [37]  NA5205 [38]  NA5204 [38]  PA850 [13] PA858 [13]	JN544 JN547 JN658 JP043	
HBS039  (22-15010B) M10x1.50x175mm (x10)	JD538  (x4) (31-029472-00) TU3JP JD551  (x2) (31-029803-00) TU3M JD5828  HA5028  JC702  (x2) (31-029804-00) JE189  (31-029805-00) TU3M JE5072 (MLS)	JN658 (50-026853-00)	JJ586 (31-029806-00) PB852 16x24x1.5mm PA349 (33-102290-10) 22x16x2mm	HR642 	NF817 36x50x7mm, FPM (50-319112-00) NF870  42x66x6mm, FPM/ACM (50-319113-00) NF857  85x105x9mm, FPM/ACM (50-319478-00)	HL5011 [245]  HR564 [37]  NA5205 [38]  NA5204 [38]  PA850 [13] PA858 [13]	JN544 JN547 JN658 JP043	
HBS039  (22-15010B) M10x1.50x175mm (x10)	JD530  (x4) JC702  (x2) (31-029804-00) JE189  (31-029805-00)	JN658 (50-026853-00)	JJ587 PB852 16x24x1.5mm PA349 (33-102290-10) 22x16x2mm	HR642 	NF817 36x50x7mm, FPM (50-319112-00) NF870  42x66x6mm, FPM/ACM (50-319113-00) NF857  85x105x9mm, FPM/ACM (50-319478-00)	HL5011 [245]  NA5205 [38]  NA5204 [38] 	JN544 JN547 JN658 JP043	
HBS260  (22-53011B) M11x1.50x168mm (x10)	JD519  (x2) JD520  (x4)	JP043 (50-028759-00)	JJ283 [6] (31-025198-10) PA349 (33-102290-10) 22x16x2mm PB907 14x21x2mm	HR569  24-30667-00/0	NF817 36x50x7mm, FPM (50-319112-00) NA5191  42x62x7mm, PTFE (50-319500-00) NA5192  90x110x7mm, PTFE (50-319501-00)	HL5019 [245]  HR566 [37]  NA5205 [38]  NA5204 [38]  KA611 [13]	JN544 JN547 JN658 JP043	



KW/PS

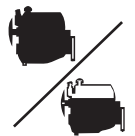

306 1.8L 16V		03/97 → 04/02		65		AD5100 (Fibre)		CD5100			
306 Convertible 1.8L 16V		07/00 → 04/02						→ Eng.7965			
XU7JP4 (LFY)	1761	4	83.00	MPi	81/110						
306 1.8L D Diesel		05/93 → 05/01		66		BX830 (Fibre), 1.36mm, 1 Notch (30-028484-00) -0.56 → 0.67mm BX840 (Fibre), 1.40mm, 2 Notches (30-028485-00) -0.68 → 0.71mm BX850 (Fibre), 1.44mm, 3 Notches (30-028486-00) -0.72 → 0.75mm BX860 (Fibre), 1.48mm, 4 Notches (30-028487-00) -0.76 → 0.79mm BX870 (Fibre), 1.52mm, 5 Notches (30-028488-00) -0.80 → 0.83mm		DJ720▲ (21-25202-22/0)		EL890 (22-25198-01/0) GJ720▲ (20-25202-02/0)	
XUD7 (A9A)	1769	4	80.00		44/60						
306 1.9L D Diesel		09/98 → 04/02		67		AA5830 (Steel Elastomer), 1.26mm, 1 Hole (30-029190-00) -0.51 → 0.54mm AA5840 (Steel Elastomer), 1.30mm, 2 Holes (30-029191-00) -0.55 → 0.58mm AA5850 (Steel Elastomer), 1.34mm, 3 Holes (30-029192-00) -0.59 → 0.62mm AA5860 (Steel Elastomer), 1.38mm, 4 Holes (30-029193-00) -0.63 → 0.66mm AA5870 (Steel Elastomer), 1.42mm, 5 Holes (30-029194-00) -0.67 → 0.70mm AA5880 (Steel Elastomer), 1.46mm, 6 Holes (30-029195-00) -0.71 → 0.75mm		CA5830▲ (21-29482-20/0)		EA5830	
DW8 (WJZ)/DW8B (WJY)	1868	4	82.20	SOHC	51/69						
306 1.9L D Diesel		05/93 → 04/02		68		BX880 (Fibre), 1.36mm, 1 Notch (30-028475-00) -0.56 → 0.67mm BX890 (Fibre), 1.40mm, 2 Notches (30-028476-00) -0.68 → 0.71mm BX900 (Fibre), 1.44mm, 3 Notches (30-028477-00) -0.72 → 0.75mm BX910 (Fibre), 1.48mm, 4 Notches (30-028478-00) -0.76 → 0.79mm BX920 (Fibre), 1.52mm, 5 Notches (30-028479-00) -0.80 → 0.83mm		DJ720▲ (21-25202-22/0)		EL890 (22-25198-01/0) GJ720▲ (20-25202-02/0)	
306 1.9L SLD Diesel		06/94 → 05/01									
XUD9 (DJZ/D9A/162)	1905	4	83.00		47/64						
XUD9A (DJY/D9B)	1905	4	83.00		51/69						

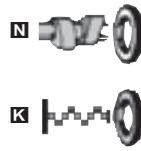
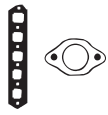

AA5830, AA5840,
AA5850, AA5860,
AA5870, AA5880



BX830, BX840,
BX850, BX860,
BX870, BX880,
BX890, BX900,
BX910, BX920



JC759



























JD539



JN544



JJ283







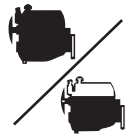



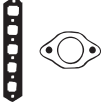

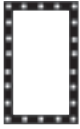































































<p>HBS089 </p> <p>(22-15016B)</p> <p>M11x1.50x159mm (x10)</p>	<p>JD5832 </p> <p>JD539 </p>		<p>PB907</p> <p>14x21x2mm</p>	<p>HR5080 </p> <p>(24-30710-45/0)</p> <p>→Eng.07359</p> <p>HR5081 </p> <p>(24-30721-87/0)</p> <p>Eng.07360 →</p> <p>→Eng.07965</p>	<p>NF817  36x50x7mm, FPM (50-319112-00)</p> <p>NA5191  42x62x7mm, PTFE (50-319500-00)</p> <p>NA5192  90x110x7mm, PTFE (50-319501-00)</p>	<p>HL5019 [245] </p> <p>HR566 [37] </p> <p>NA5205 [38] </p> <p>NA5204 [38] </p> <p>KA611 [13]</p>
<p>HBS084 </p> <p>(22-15005B)</p> <p>M12x1.50x123mm (x10)</p> <p>→Eng.08469</p>	<p>JC759 [60]</p> <p>(31-028417-00)</p> <p>(Steel)</p>	<p>JN544</p> <p>(50-025202-00)</p>	<p>JJ283 [6]</p> <p>(31-025198-10)</p> <p>PA349</p> <p>(33-102290-10)</p> <p>22x16x2mm</p> <p>PB907</p> <p>14x21x2mm</p>	<p>HR569 </p> <p>24-30667-00/0</p>	<p>NF841  35x50x8mm, FPM (50-319310-00)</p> <p>→01/94</p> <p>NB959  35x50x7mm, FPM (50-306644-50)</p> <p>02/94 →</p> <p>NA5191  42x62x7mm, PTFE (50-319500-00)</p> <p>NA5192  90x110x7mm, PTFE (50-319501-00)</p>	<p>HL5010 [245] </p> <p>HL5012 [245] </p> <p>NA5205 [38] </p> <p>NA5204 [38] </p> <p>KA611 [13]</p>
<p>HBS084 </p> <p>(22-15005B)</p> <p>M12x1.50x123mm (x10)</p> <p>→Eng.08469</p> <p>HBS245 </p> <p>(22-53008B)</p> <p>M12x1.50x125mm (x10)</p> <p>Eng.08470 →</p>	<p>HA5008 </p> <p>JD5192  (x2)</p>	<p>JM5088 </p> <p>JM5089 </p>	<p>KG5157</p> <p>10x20x2mm</p> <p>PB907</p> <p>14x21x2mm</p>	<p>HR569 </p> <p>24-30667-00/0</p>	<p>NB959  35x50x7mm, FPM (50-306644-50)</p> <p>NA5191  42x62x7mm, PTFE (50-319500-00)</p> <p>NA5192  90x110x7mm, PTFE (50-319501-00)</p>	<p>HL5012 [245] </p> <p>NA5205 [38] </p> <p>NA5204 [38] </p>
<p>HBS084 </p> <p>(22-15005B)</p> <p>M12x1.50x123mm (x10)</p>	<p>JC759 [60]</p> <p>(31-028417-00)</p> <p>(Steel)</p>	<p>JN544</p> <p>(50-025202-00)</p>	<p>JJ283 [6]</p> <p>(31-025198-10)</p> <p>PA349</p> <p>(33-102290-10)</p> <p>22x16x2mm</p> <p>PB907</p> <p>14x21x2mm</p>	<p>HR569 </p> <p>24-30667-00/0</p>	<p>NB959  35x50x7mm, FPM (50-306644-50)</p> <p>NA5191  42x62x7mm, PTFE (50-319500-00)</p> <p>NA5192  90x110x7mm, PTFE (50-319501-00)</p>	<p>HL5012 [245] </p> <p>NA5205 [38] </p> <p>NA5204 [38] </p> <p>KA611 [13]</p>



KW/PS



306 1.9L D Diesel		03/98 → 04/02		69				
XUD9BSD (DHV/DHW)	1905	4	83.00		55/75	BX930 (Steel Elastomer), 1.36mm, 1 Notch (30-028503-00) BX940 (Steel Elastomer), 1.40mm, 2 Notches (30-028504-00) BX950 (Steel Elastomer), 1.44mm, 3 Notches (30-028505-00) BX960 (Steel Elastomer), 1.48mm, 4 Notches (30-028506-00) BX970 (Steel Elastomer), 1.52mm, 5 Notches (30-028507-00) BX980 (Steel Elastomer), 1.59mm → 0.83mm →	DJ720▲ (21-25202-22/0)	EL890 (22-25198-01/0) GJ720▲ (20-25202-02/0)
306 1.9L DT Diesel		05/93 → 05/01		70				
306 1.9L SRDT Diesel		06/94 → 05/01						
306 1.9L TD Diesel		02/97 → 04/02						
XUD9TE (DHX/DHY/D8A)	1905	4	83.00		66/89	BX930 (Steel Elastomer), 1.36mm, 1 Notch (30-028503-00) BX940 (Steel Elastomer), 1.40mm, 2 Notches (30-028504-00) BX950 (Steel Elastomer), 1.44mm, 3 Notches (30-028505-00) BX960 (Steel Elastomer), 1.48mm, 4 Notches (30-028506-00) BX970 (Steel Elastomer), 1.52mm, 5 Notches (30-028507-00) BX980 (Steel Elastomer), 1.59mm → 0.83mm →	DJ720▲ (21-25202-22/0)	EL890 (22-25198-01/0) GJ720▲ (20-25202-02/0)
306 2.0L		05/93 →		71				
						BV140 (Fibre), 1.25mm (30-028760-00) BY320 (Fibre), 1.45mm [34]	CY080▲ (21-28759-21/0)	ES820 (22-25198-03/0)
306 2.0L		03/97 → 04/02		72				
306 2.0L 16V		03/97 → 05/01						
306 2.0L S16		03/96 → 05/01						
306 Convertible 2.0L 16V		03/97 → 04/02						
XU10J4R (RFV/R6E)	1998	4	86.00	MPi	99/135	AY070 (Fibre) (30-029744-00)	CY070	
XU10J4RS (RFS)	1998	4	86.00	Carburettor	120- 123/ 163- 167			
306 2.0L HDI 90 Diesel		06/99 → 04/02		73				
DW10TD (RHY)	1997	4	85.00	Common Rail	63/86	AC5011 (MLS), 1.30mm, 1 Hole → 0.47 → 0.605mm AC5031 (MLS), 1.40mm, 3 Holes (30-029479-10) → 0.655 → 0.705mm AC5051 (MLS), 1.50mm, 5 Holes (30-029481-10) → 0.755 → 0.83mm	CC5010▲ (21-29484-20/0)	EA5830
306 2.0L S16		05/93 → 05/01		74				
XU10J4 (RFT)	1998	4	86.00	MPi	110- 112/ 150- 152	AY090 (Fibre), 1.25mm (30-028762-00) AY100 (Fibre), 1.45mm [34]	CY090▲	ES820 (22-25198-03/0)
XU10J4 (RFT/RFY)	1998	4	86.00	MPi	112/152			







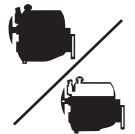



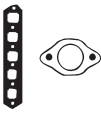

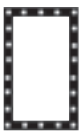

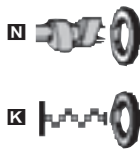





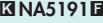
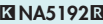

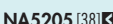
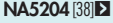



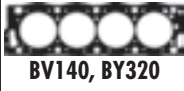









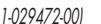











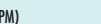



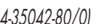



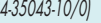

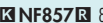

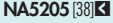
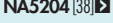



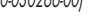

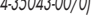

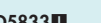

									 AY070	 AY090, AY100	 BV140, BY320	 BX930, BX940, BX950, BX960, BX970, BX980	 HA510	 JC759	 JC991	 JD520	 JD536	 JD539	 JN544	 JP043	 JP044	 JJ283	
HBS084  (22-15005B) M12x1.50x123mm (x10)	JC759 [60] (31-028417-00) (Steel)	JN544 (50-025202-00)	JJ283 [6] (31-025198-10) ● PA349 (33-102290-10) 22x16x2mm ● PB907 14x21x2mm	HR569  24-30667-00/0	NB959 35x50x7mm, FPM (50-306644-50) NA5191  42x62x7mm, PTFE (50-319500-00) NA5192  90x110x7mm, PTFE (50-319501-00)	HL5012 [245]  NA5205 [38]  NA5204 [38]  KA611 [13]																	
HBS088  (22-15014B) M12x1.50x145mm (x10) →Eng.08574 HBS277  (22-53018B) M12x1.50x148mm (x10) Eng.08575 →	JC759 [60] (31-028417-00) (Steel) JC991 (31-028595-00) US87 & CEE19-5	JN544 (50-025202-00)	JJ283 [6] (31-025198-10) ● PA349 (33-102290-10) 22x16x2mm ● PB907 14x21x2mm	HR569  24-30667-00/0	NF841 35x50x8mm, FPM (50-319310-00) →12/93 NB959 35x50x7mm, FPM (50-306644-50) 01/94 → NA5191  42x62x7mm, PTFE (50-319500-00) NA5192  90x110x7mm, PTFE (50-319501-00)	HL5010 [245]  HL5012 [245]  NA5205 [38]  NA5204 [38]  KA611 [13]																	
HBS084  (22-15005B) M12x1.50x123mm (x10)	HA510  JD520  (x4)	JP043 (50-028759-00)	JJ283 [6] (31-025198-10) ● PA349 (33-102290-10) 22x16x2mm ● PB907 14x21x2mm	HR569  24-30667-00/0	NF817 36x50x7mm, FPM (50-319112-00) NA5191  42x62x7mm, PTFE (50-319500-00) NA5192  90x110x7mm, PTFE (50-319501-00)	HL5019 [245]  NA5205 [38]  NF836 [38]  NA5204 [38]  NF826 [38]  KA611 [13]																	
HBS087  (22-15013B) M12x1.50x110mm (x10) →Eng.08581 HBS278  (22-53019B) M12x1.50x110mm (x10) Eng.08582 →	JD536  JD539 		● PB907 14x21x2mm	HR5080  (24-30710-45/0) →Eng.07359 HR5081  (24-30721-87/0) Eng.07360 → →Eng.07965	NF817 (x2) 36x50x7mm, FPM (50-319112-00) NA5191  42x62x7mm, PTFE (50-319500-00) NA5192  90x110x7mm, PTFE (50-319501-00)	HL5019 [245]  NA5205 [38]  NA5204 [38]  KA611 [13] XU10J4RS																	
HBS261  (22-53014B) M12x1.50x131mm (x10)	JD5191  JD5190 	JM5087	● KG5157 10x20x2mm ● PB907 14x21x2mm	HR5046  (x2)	NA5035 27x47x7mm, FPM (50-319474-00) NA5191  42x62x7mm, PTFE (50-319500-00) NA5192  90x110x7mm, PTFE (50-319501-00)	HL5016 [245]  NA5205 [38]  NA5204 [38] 																	
HBS087  (22-15013B) M12x1.50x110mm (x10) →Eng.08581 HBS278  (22-53019B) M12x1.50x110mm (x10) Eng.08582 →	JD536 	JP044 (50-028763-00)	JJ283 [6] (31-025198-10) ● PA349 (33-102290-10) 22x16x2mm ● PB907 14x21x2mm	HR642  (x2)	NF817 (x2) 36x50x7mm, FPM (50-319112-00) NA5191  42x62x7mm, PTFE (50-319500-00) NA5192  90x110x7mm, PTFE (50-319501-00)	HL5019 [245]  NA5205 [38]  NA5204 [38]  KA611 [13] XU10J4RS																	

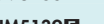
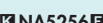

KW/PS



306 2.0L ST 07/94 → 05/01 75						BV140 (Fibre), 1.25mm (30-028760-00)	CY080▲ (21-28759-21/0)	ES820 (22-25198-03/0)
306 2.0L XSi 05/93 → 05/01								
306 Convertible 2.0L 03/94 → 04/02								
XU10J2 (RFX)	1998	4	86.00	MPi	89/96/ 121- 131	AD5700 (Fibre), 1.25mm (30-026851-00) AD5710 (Fibre), 1.50mm [34] (30-029799-00)	DT012▲ (21-26853-20/0)	EH951 [8] (22-25605-00/0)
307 1.4L 08/00 → 76								
TU3JP (KFW/K6D)	1360	4	75.00	MPi, SOHC	55/75			
307 1.4L 16V 11/03 → 77						AG9030 (Fibre), 1.4mm (30-030263-00)	CG9030	EG9030
KFU (ET3J4)	1360	4	75.00	Carburettor	65/88			
307 1.4L HDI Diesel 10/01 → 78						AD5130 (MLS), 1.25mm, 2 Notches, +3 Notches (30-029277-00) AD5140 (MLS), 1.30mm, 3 Notches, +3 Notches (30-029278-00) AD5150 (MLS), 1.35mm, 1 Notch, +3 Notches (30-029279-00) AD5160 (MLS), 1.40mm, +3 Notches, 4 Notches (30-029280-00) AD5170 (MLS), 1.45mm, +3 Notches, 5 Notches (30-029281-00)	CD5130▲ (21-29277-00/0)	ED5130
DV4TD (8HZ)	1398	4	73.70	Direct Injection	50/68			
DV4TD (8HX)	1398	4	73.70	Common Rail	52/71			
307 1.6L 16V 08/00 → 79								
TU5JP4 (NFU/N6A)	1587	4	78.50	MPi	80/109	AD5180 (MLS), 0.62mm (30-029785-00)	CD5180 (21-29785-20/0)	ED5180
307 1.6L HDI Diesel 04/05 → 80								
307 1.6L HDI 110 FAP Diesel 02/04 →						AD5130 (MLS), 1.25mm, 2 Notches, +3 Notches (30-029277-00) AD5140 (MLS), 1.30mm, 3 Notches, +3 Notches (30-029278-00) AD5150 (MLS), 1.35mm, 1 Notch, +3 Notches (30-029279-00) AD5160 (MLS), 1.40mm, +3 Notches, 4 Notches (30-029280-00) AD5170 (MLS), 1.45mm, +3 Notches, 5 Notches (30-029281-00)	CD5140▲ (21-29278-00/0)	
DV6ATED4 (9HX)	1560	4	75.00	HDi	66/92			
DV6TED4 (9HY)	1560	4	75.00	HDi, DOHC	80/109			
307 2.0L 03/02 → 81								
307 2.0L 16V 08/00 →						AD5300 (MLS)	CD5300	ED5300
EW10J4 (RFN)	1997	4	85.00	MPi, DOHC	100/136			
EW10J4S (RFK)	1997	4	85.00	Injection, DOHC	130/177	AD5300 (MLS)	CD5300	ED5300
307 2.0L 16V 03/05 → 82								
EW10A (RFJ)	1997	4	85.00	MPi, DOHC	103/140	AD5300 (MLS)	CD5300	ED5300
EW10J4S (RFK)	1997	4	85.00	Injection, DOHC	130/177			

								
HBS084  (22-15005B) M12x1.50x123mm (x10)	HA510  JD520  (x4) JP043 (50-028759-00)	JJ283 [6] (31-025198-10) ● PA349 (33-102290-10) 22x16x2mm ● PB907 14x21x2mm	HR569  24-30667-00/0	NF817 36x50x7mm, FPM (50-319112-00) NA5191  42x62x7mm, PTFE (50-319500-00) NA5192  90x110x7mm, PTFE (50-319501-00)	HL5019 [245]  NA5205 [38]  NA5204 [38]  KA611 [13]	 AD5130, AD5140, AD5150, AD5160, AD5170  AD5180  AD5700, AD5710  BV140, BY320  HA510  JC702  JD520  JD538  JN658  JP043  JJ283		
HBS039  (22-15010B) M10x1.50x175mm (x10)	JD538  (x4) (31-029472-00) JD5828  HA5028  JC702  (x2) (31-029804-00)  JE5072 (MLS)	JN658 (50-026853-00)	● PB852 16x24x1.5mm	HR642 	NF817 36x50x7mm, FPM (50-319112-00) NF870  42x66x6mm, FPM/ACM (50-319113-00) NF857  85x105x9mm, FPM/ACM (50-319478-00)	HL5011 [245]  HR564 [37]  NA5205 [38]  06/99 → NA5204 [38]  06/99 → PA850 [13]		
	JD5882  (FPM) JD5831   JE5072 (MLS)	JM7051 JM7052						
HBS359  (22-15018B) M11x1.50x150mm (x10)	HA5029  (24-35042-80/0) JD5829  (31-030265-00)		● KG5157 10x20x2mm		NA5258 27x47x7mm NA5259  40x55x6.4mm	HL5033 [245] 		
HBS254  (22-53009B) M10x1.50x122mm (x10)	HA5032  (24-35043-10/0) JD5831   JE5072 (MLS)	JM7035 (50-030267-00)	JH5107 (ACM) ● PB852 16x24x1.5mm ● PA349 (33-102290-10) 22x16x2mm		NA5260 38x50x6mm NF870  42x66x6mm, FPM/ACM (50-319113-00) NF857  85x105x9mm, FPM/ACM (50-319478-00)	HL5038 [245]  NA5205 [38]  NA5204 [38] 		
HBS359  (22-15018B) M11x1.50x150mm (x10)	JD5830  (50-030266-00) HA5031   (24-35043-00/0) HA5030   (24-35042-90/0) JD5829  (31-030265-00)	JM7034 (50-030264-00)	● KG5157 10x20x2mm		NA5258 27x47x7mm NA5259  40x55x6.4mm	HL5033 [245] 		
HBS259  (22-53010B) M11x1.50x144.5mm (x10)	JD5833 	JM5283  JM5139 	● PB907 14x21x2mm		NA5256  40x55x6.5mm	HL5037 [245] 		
HBS259  (22-53010B) M11x1.50x144.5mm (x10)	JD5835  50-030167-00 (FPM)	JM5283  JM5139 	● PB907 14x21x2mm		NA5256  40x55x6.5mm	HL5037 [245] 		











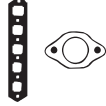

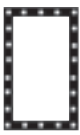

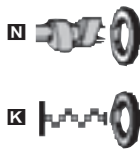











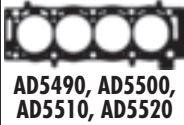





























































































PEUGEOT



KW/PS



307 2.0L HDI 110 FAP Diesel 08/00 → 83				AD5490 (MLS), 1.25mm [30-029789-00]	CC5010▲ [21-29484-20/0] → Eng.8331	EA5830
307 2.0L HDI 135 FAP Diesel 10/03 →				AD5500 (MLS), 1.30mm [30-029790-00]	CC5011▲ Eng.8332 →	
DW10ATED (RHS)	1997	4	85.00	Common Rail, DOHC	81/110	
DW10BTED4 (RHR)	1997	4	85.00	Direct Injection	100/136	
307 2.0L HDI 90 Diesel 08/00 → 84				AC5011 (MLS), 1.30mm, 1 Hole -0.47 → -0.605mm	CC5010▲ [21-29484-20/0]	EA5830
DW10TD (RHY)	1997	4	85.00	Common Rail	63/86	
				AC5031 (MLS), 1.40mm, 3 Holes [30-029479-10]		
				-0.655 → -0.705mm		
				AC5051 (MLS), 1.50mm, 5 Holes [30-029481-10]		
				-0.755 → -0.83mm		
308 2.0L HDI Diesel 09/07 → 85					CD5500▲	ED5500
DW10BTED4 (RHR)	1997	4	85.00	Direct Injection	100/136	
309 1.1L 10/85 → 07/89 86				BF100 (Fibre), 1.30mm	DF106▲■○ [21-21887-20/0]	EF102
E1	1118	4	74.00	Carburettor	40/54	
				BG480 (Fibre), 1.80mm [34]	DF107▲■	
309 1.1L 08/90 → 12/93 87				AD5700 (Fibre), 1.25mm [30-026851-00]	DT010 [21-26851-20/0]	EH951 [8] [22-25605-00/0]
TU1M (HDZ)	1124	4	72.00	SPi	44/60	
				AD5710 (Fibre), 1.50mm [34] [30-029799-00]	DT012▲ [21-26853-20/0]	EH952 [22-25605-02/0]
309 1.3L 10/85 → 07/89 88				BF170 (Fibre), 1.30mm [30-023495-10]	DF106▲■○ [21-21887-20/0]	EF102
G1 / G2	1294	4	76.70	Carburettor	47-48/ 64-65	
				BG490 (Fibre), 1.80mm [34]	DF107▲■	
309 1.4L 03/89 → 12/93 89				AD5700 (Fibre), 1.25mm [30-026851-00]	DT010 [21-26851-20/0]	EH951 [8] [22-25605-00/0]
TU3F2 (K1D)	1360	4	75.00	Carburettor	49/67	
TU3M (KDZ)	1360	4	75.00	SPi	55/75	
TU3M (KDY)	1360	4	75.00	Carburettor	55-58/ 75-79	
TU3F2 (K2B)	1360	4	75.00	Carburettor	62/84	
309 1.4L i 01/91 → 90				BY130 (Fibre), 1.28mm [30-029099-00]	DY130▲ [21-26853-21/0]	EY130 [22-28758-00/0]
TU3 F (Cast Iron Block) / TU3 F2 (Cast Iron Block) / TU3 F2C (Cast Iron Block) / TU3 FJ2 (Cast Iron Block) / TU3 FM (Cast Iron Block)	1360	4	75.00	SPi		
				BY170 (Fibre), 1.50mm [34]		
309 1.5L 06/87 → 12/89 91				BF170 (Fibre), 1.30mm [30-023495-10]	DF106▲■○ [21-21887-20/0]	EF102
Y2	1442	4	76.70	Carburettor	61-63/ 83-86	
				BG490 (Fibre), 1.80mm [34]	DF107▲■	

								
HBS261  (22-53014B) M12x1.50x131mm (x10)		JM5141 (50-030271-00)	● KG5157 10x20x2mm ● PB907 14x21x2mm	HR5046  (x2)	 NA5035 27x47x7mm, FPM (50-319474-00)  NA5191  42x62x7mm, PTFE (50-319500-00)  NA5192  90x110x7mm, PTFE (50-319501-00)	HL5016 [245]  NA5205 [38]  NA5204 [38] 	 AD5490, AD5500, AD5510, AD5520  AD5700, AD5710  BF100, BG480  BF170, BG490  BY130  BY170  JB836  JB837  JC702  JD551  JE189  JN238  JN658  HC341  JJ586  JJ587	
HBS261  (22-53014B) M12x1.50x131mm (x10)	JD5191  JD5190 	JM5087	● KG5157 10x20x2mm ● PB907 14x21x2mm	HR5046  (x2)	 NA5035 27x47x7mm, FPM (50-319474-00)  NA5191  42x62x7mm, PTFE (50-319500-00)  NA5192  90x110x7mm, PTFE (50-319501-00)	HL5016 [245]  NA5205 [38]  NA5204 [38] 		
	JD5881 	HM5289 	● KG5157 10x20x2mm ● PB907 14x21x2mm	HR5046  (x2)	 NA5035 27x47x7mm, FPM (50-319474-00)  NA5191  42x62x7mm, PTFE (50-319500-00)  NA5192  90x110x7mm, PTFE (50-319501-00)	HL5016 [245]  NA5205 [38]  NA5204 [38] 		
	JB836  JB837  (31-021888-10)	JN238 (31-021887-00)	HC341  ● KG5290 20.4x27x3mm		 NF694  40x58x8mm, ACM  NF692  71x88x8mm, MVQ	NF836 [38]  NF826 [38] 		
HBS039  (22-15010B) M10x1.50x175mm (x10)	JD551  (x2) (31-029803-00) JC702  (x2) (31-029804-00) ● JE189 (31-029805-00)	JN658 (50-026853-00)	JJ586 (31-029806-00) ● PB852 16x24x1.5mm ● PA349 (33-102290-10) 22x16x2mm	HR642 	 NF817 36x50x7mm, FPM (50-319112-00)  NF870  42x66x6mm, FPM/ACM (50-319113-00)  NF857  85x105x9mm, FPM/ACM (50-319478-00)	HL5011 [245]  HR564 [37]  NF836 [38]  NF826 [38]  PA850 [13] PA858 [13]		
	JB836  JB837  (31-021888-10)	JN238 (31-021887-00)	HC341  ● PA349 (33-102290-10) 22x16x2mm	HR569  24-30667-00/0	 NF694  40x58x8mm, ACM  NF692  71x88x8mm, MVQ	NF836 (x2) [38]  NF826 [38] 		
HBS039  (22-15010B) M10x1.50x175mm (x10)	JD551  (x2) (31-029803-00) JC702  (x2) (31-029804-00) ● JE189 (31-029805-00)	JN658 (50-026853-00)	JJ586 (31-029806-00) ● PB852 16x24x1.5mm ● PA349 (33-102290-10) 22x16x2mm	HR642 	 NF817 36x50x7mm, FPM (50-319112-00)  NF870  42x66x6mm, FPM/ACM (50-319113-00)  NF857  85x105x9mm, FPM/ACM (50-319478-00)	HL5011 [245]  HR564 [37]  NF836 [38]  NF826 [38]  PA850 [13] PA858 [13]		
HBS039  (22-15010B) M10x1.50x175mm (x10)	JC702  (x2) (31-029804-00) ● JE189 (31-029805-00)	JN658 (50-026853-00)	JJ587 ● PB852 16x24x1.5mm	HR642 	 NF817 36x50x7mm, FPM (50-319112-00)  NF870  42x66x6mm, FPM/ACM (50-319113-00)  NF857  85x105x9mm, FPM/ACM (50-319478-00)	HL5011 [245]  NF836 [38]  NF826 [38] 		
	JB836  JB837  (31-021888-10)	JN238 (31-021887-00)	HC341  ● PA349 (33-102290-10) 22x16x2mm	HR569  24-30667-00/0	 NF694  40x58x8mm, ACM  NF692  71x88x8mm, MVQ	NF836 (x2) [38]  NF826 [38] 		



KW/PS



309 1.6L					10/85 → 12/93	92	BL650 (Fibre), 1.20mm (30-026859-10)		DN590▲ (21-25204-21/0)	EL650 (22-25198-00/0) GL650
XU51C (B1A/B1C/B1E)	1580	4			59/80					
	1580	4			69/94					
	1580	4	83.00	Carburettor	53-55/ 72-75		BR510 (Fibre), 1.44mm [34] (30-026858-10)			
XU5CP (BAZ)	1580	4	83.00	Carburettor	54-55/ 74-75					
XU51C (B1A/B1C)	1580	4	83.00	Carburettor	55/75					
XU5M (BDZ)	1580	4	83.00	SPi	65-66/ 88-90					
XU5M3Z (BDY)	1580	4	83.00	Carburettor	65-66/ 88-90					
XU5M2Z (BDY)	1580	4	83.00	Carburettor	65-71/ 88-97					
XU52C (B2A)	1580	4	83.00	Carburettor	68/92					
XU5J (180)/XU5J (B6B)	1580	4	83.00	MPi	76/103					
	1592	4			69/94					
309 1.8L D Diesel					07/89 → 12/93	93	BX830 (Fibre), 1.36mm, 1 Notch (30-028484-00) -0.56 → 0.67mm		DJ720▲ (21-25202-22/0)	EL890 (22-25198-01/0) GJ720▲ (20-25202-02/0)
XUD7 (161A)	1769	4	80.00		44/60					
							BX840 (Fibre), 1.40mm, 2 Notches (30-028485-00) -0.68 → 0.71mm			
							BX850 (Fibre), 1.44mm, 3 Notches (30-028486-00) -0.72 → 0.75mm			
							BX860 (Fibre), 1.48mm, 4 Notches (30-028487-00) -0.76 → 0.79mm			
							BX870 (Fibre), 1.52mm, 5 Notches (30-028488-00) -0.80 → 0.83mm			
309 1.8L TD Diesel					08/89 → 12/93	94	BR780 (Fibre), 1.65mm, 2 Notches -0.65 → 0.77mm		DJ720▲ (21-25202-22/0)	EL890 (22-25198-01/0) GJ720▲ (20-25202-02/0)
XUD7TE (A8B)	1769	4	80.00		57/78					
							BR790 (Fibre), 1.80mm, 3 Notches (30-026855-10) -0.77 → 0.82mm			
309 1.9L					10/85 → 12/93	95	BL650 (Fibre), 1.20mm (30-026859-10)		DN590▲ (21-25204-21/0)	EL650 (22-25198-00/0) GL650
309 1.9L GTI					10/86 → 12/93					
XU9S (D2B)	1905	4	83.00	Carburettor	75/102					
XU9J1 (DFZ)/XU9JAZ (DKZ)	1905	4	83.00	MPi	90/122		BR510 (Fibre), 1.44mm [34] (30-026858-10)			
XU9M (DDZ)	1905	4	83.00	SPi	90/122					
XU9JA (D6B)	1905	4	83.00	MPi, SOHC	94-96/ 128- 131					

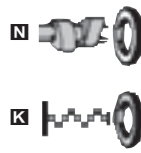
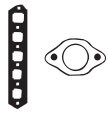

BL650



BR780, BR790



BX830, BX840,
BX850, BX860,
BX870



JC415



JC423



JC750



JC991





JN544





JN547



JJ283



HBS038 
(22-15003B)
M11x1.50x175mm (x10)
HBS083 
(22-15002B)
M11x1.50x168mm (x10)

JC750 
JC415  (x4)
(31-025205-20)

JN547
(50-025204-10)

JJ283 [6]
(31-025198-10)
● **PA349**
(33-102290-10)
22x16x2mm
● **PB907**
14x21x2mm

HR569 
24-30667-00/0

NF817  36x50x7mm, FPM
(50-319112-00)
NA5191  42x62x7mm, PTFE
(50-319500-00)
NA5192  90x110x7mm, PTFE
(50-319501-00)

HL5019 [245] 
HR566 [37] 
NF836 [38] 
NF826 [38] 



HBS084 
(22-15005B)
M12x1.50x123mm (x10)



JC423  (x2)
(31-025199-10)

JN544
(50-025202-00)

JJ283 [6]
(31-025198-10)
● **PA349**
(33-102290-10)
22x16x2mm
● **PB907**
14x21x2mm

HR569 
24-30667-00/0

NF841  35x50x8mm, FPM
(50-319310-00)
NA5191  42x62x7mm, PTFE
(50-319500-00)
NA5192  90x110x7mm, PTFE
(50-319501-00)

HL5010 [245] 
NF836 [38] 
NF826 [38] 
KA611 [13]



HBS084 
(22-15005B)
M12x1.50x123mm (x10)

JC991
(31-028595-00)
01/91 →



JN544
(50-025202-00)



JJ283 [6]
(31-025198-10)
● **PA349**
(33-102290-10)
22x16x2mm
● **PB907**
14x21x2mm

HR569 
24-30667-00/0

NF841  35x50x8mm, FPM
(50-319310-00)
NA5191  42x62x7mm, PTFE
(50-319500-00)
NA5192  90x110x7mm, PTFE
(50-319501-00)

HL5010 [245] 
NF836 [38] 
NF826 [38] 
KA611 [13]



HBS038 
(22-15003B)
M11x1.50x175mm (x10)
HBS083 
(22-15002B)
M11x1.50x168mm (x10)





JC750 
JC415  (x4)
(31-025205-20)

JN547
(50-025204-10)

JJ283 [6]
(31-025198-10)
● **PA349**
(33-102290-10)
22x16x2mm
● **PB907**
14x21x2mm

HR569 
24-30667-00/0

NF817  36x50x7mm, FPM
(50-319112-00)
NA5191  42x62x7mm, PTFE
(50-319500-00)
NA5192  90x110x7mm, PTFE
(50-319501-00)











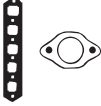

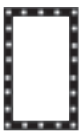

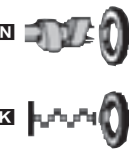

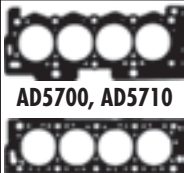



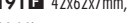
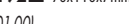























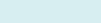

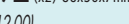
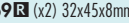
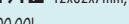
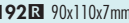







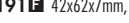
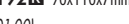









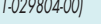

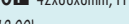
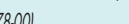















HL5019 [245] 
HR566 [37] 
NF836 [38] 
NF826 [38] 
KA611 [13]

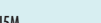

KW/PS

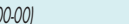
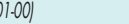

309 1.9L D Diesel				06/86 → 12/93		96	BX880 (Fibre), 1.36mm, 1 Notch (30-028475-00) -0.56 → 0.67mm		DJ720▲ (21-25202-22/0)	EL890 (22-25198-01/0) GJ720▲ (20-25202-02/0)
XUD9 (D9A)/XUD9 (DJZ/D9A/162)	1905	4	83.00		47/64					
XUD9 (162)	1905	4	83.00		47-48/ 64-65		BX890 (Fibre), 1.40mm, 2 Notches (30-028476-00) -0.68 → 0.71mm			
							BX900 (Fibre), 1.44mm, 3 Notches (30-028477-00) -0.72 → 0.75mm			
							BX910 (Fibre), 1.48mm, 4 Notches (30-028478-00) -0.76 → 0.79mm			
							BX920 (Fibre), 1.52mm, 5 Notches (30-028479-00) -0.80 → 0.83mm			
309 1.9L GTI 16V				08/89 → 12/93		97	BR510 (Fibre), 1.44mm [34] (30-026858-10)		DR510	EL650 (22-25198-00/0)
XU9J4 (DFW)	1905	4	83.00	MPi	90/122					
XU9J4 (D6C/DFW)	1905	4	83.00	MPi	116/158					
404 1.8L i				05/93 →		98	BL650 (Fibre), 1.20mm (30-026859-10) BR510 (Fibre), 1.44mm [34] (30-026858-10)		CY130▲ (21-28759-20/0)	EL650 (22-25198-00/0)
XU7JP (LFW)/XU7JP (LFZ)	1761	4	83.00	MPi	74/100					
405 1.4L				01/87 → 10/96		99	AD5700 (Fibre), 1.25mm (30-026851-00) AD5710 (Fibre), 1.50mm [34] (30-029799-00)		DT010 (21-26851-20/0) DT012▲ (21-26853-20/0)	EH951 [8] (22-25605-00/0) EH952 (22-25605-02/0)
TU 3	1360	4	75.00	Injection	44-51/ 60-69					
TU3MC (KDX/KDY)	1360	4	75.00	SPi	55-56/ 75-76					
405 1.6L				01/87 → 12/92		100	BL650 (Fibre), 1.20mm (30-026859-10) BR510 (Fibre), 1.44mm [34] (30-026858-10)		DN590▲ (21-25204-21/0)	EL650 (22-25198-00/0) GL650
XU51C (B1A/B1C/B1E)	1580	4	83.00	Carburettor	69/94 53-55/ 72-75					
XU5CP (BAZ)	1580	4	83.00	Carburettor	54-55/ 74-75					
XU5M (BDZ)	1580	4	83.00	SPi	65-66/ 88-90					
XU5M3Z (BDY)	1580	4	83.00	Carburettor	65-66/ 88-90					
XU5M2Z (BDY)	1580	4	83.00	Carburettor	65-71/ 88-97					
XU52C (B2A)	1580	4	83.00	Carburettor	68/92					
405 1.6L				08/92 → 10/96		101	BL650 (Fibre), 1.20mm (30-026859-10) BR510 (Fibre), 1.44mm [34] (30-026858-10)		CY130▲ (21-28759-20/0) XU5JP DN590▲ (21-25204-21/0) XU5M	EL650 (22-25198-00/0) GL650 XU5M
XU5JP (BFZ)	1580	4	83.00	MPi	65/88					
XU5M (BDZ)	1580	4	83.00	SPi	65-66/ 88-90					
XU5M3Z (BDY)	1580	4	83.00	Carburettor	65-66/ 88-90					
XU5M2Z (BDY)	1580	4	83.00	Carburettor	65-71/ 88-97					

								
HBS084  (22-15005B) M12x1.50x123mm (x10)	JC759 [60] (31-028417-00) (Steel) JC423  (x2) (31-025199-10)	JN544 (50-025202-00)	JJ283 [6] (31-025198-10) PA349 (33-102290-10) 22x16x2mm PB907 14x21x2mm	HR569  24-30667-00/0	NF841 35x50x8mm, FPM (50-319310-00) NA5191  42x62x7mm, PTFE (50-319500-00) NA5192  90x110x7mm, PTFE (50-319501-00)	HL5010 [245]  NF836 [38]  NF826 [38]  KA611 [13]	AD5700, AD5710 BL650  BX880, BX890, BX900, BX910, BX920  JC415  JC423  JC702  JC750  JC759  JD519  JD520  JD551  JE189  JN544  JN547  JN658  JP043  JP044  JJ283  JJ586 	
HBS038  (22-15003B) M11x1.50x175mm (x10)	JD5763  (x2) JD5764 	JP044 (50-028763-00)	JJ283 [6] (31-025198-10) PA349 (33-102290-10) 22x16x2mm	HR642  (x2)	NF817  (x2) 36x50x7mm, FPM (50-319112-00) NF869  (x2) 32x45x8mm, MVQ NA5191  42x62x7mm, PTFE (50-319500-00) NA5192  90x110x7mm, PTFE (50-319501-00)	HL5019 [245]  HR566 [37]  NF836 [38]  NF826 [38]  KA611 [13] LC292 (x2) [14]		
HBS260  (22-53011B) M11x1.50x168mm (x10)	JD519  JD520 	JP043 (50-028759-00)	JJ283 [6] (31-025198-10) PA349 (33-102290-10) 22x16x2mm PB907 14x21x2mm	HR569  24-30667-00/0	NF817 36x50x7mm, FPM (50-319112-00) NA5191  42x62x7mm, PTFE (50-319500-00) NA5192  90x110x7mm, PTFE (50-319501-00)	HL5019 [245]  HR566 [37]  NA5205 [38]  NF836 [38]  NA5204 [38]  NF826 [38]  KA611 [13]		
HBS039  (22-15010B) M10x1.50x175mm (x10)	JD551  (x2) (31-029803-00) JC702  (x2) (31-029804-00) JE189  (31-029805-00)	JN658 (50-026853-00)	JJ586 (31-029806-00) PB852 16x24x1.5mm PA349 (33-102290-10) 22x16x2mm	HR642 	NF817 36x50x7mm, FPM (50-319112-00) NF870  42x66x6mm, FPM/ACM (50-319113-00) NF857  85x105x9mm, FPM/ACM (50-319478-00)	HL5011 [245]  HR564 [37]  NF836 [38]  NF826 [38]  PA850 [13] PA858 [13]		
HBS038  (22-15003B) M11x1.50x175mm (x10) HBS083  (22-15002B) M11x1.50x168mm (x10)	JC750  JC415  (x4) (31-025205-20)	JN547 (50-025204-10)	JJ283 [6] (31-025198-10) PA349 (33-102290-10) 22x16x2mm PB907 14x21x2mm	HR569  24-30667-00/0	NF817 36x50x7mm, FPM (50-319112-00) NA5191  42x62x7mm, PTFE (50-319500-00) NA5192  90x110x7mm, PTFE (50-319501-00)	HL5019 [245]  HR566 [37]  NF836 [38]  NF826 [38]  KA611 [13]		
HBS038  (22-15003B) M11x1.50x175mm (x10) →Eng.07448 HBS083  (22-15002B) M11x1.50x168mm (x10) HBS260  (22-53011B) M11x1.50x168mm (x10) Eng.07448 →	JC750  XU5M JD519  (x2) XU5JP JD520  (x4) XU5JP	JN547 (50-025204-10) XU5M JP043 (50-028759-00) XU5JP	JJ283 [6] (31-025198-10) PA349 (33-102290-10) 22x16x2mm PB907 14x21x2mm	HR569  24-30667-00/0	NF817 36x50x7mm, FPM (50-319112-00) NA5191  42x62x7mm, PTFE (50-319500-00) NA5192  90x110x7mm, PTFE (50-319501-00)	HL5019 [245]  HR566 [37]  NF836 [38]  NF826 [38]  KA611 [13]		



KW/PS



405 1.8L					08/92 → 10/96	102			CY130▲	EL650
XU7JP (LFZ)	1761	4	83.00	MPi		74/100	BL650 (Fibre), 1.20mm (30-026859-10) BR510 (Fibre), 1.44mm [34] (30-026858-10)		(21-28759-20/0)	(22-25198-00/0)
405 1.8L T D Diesel					03/88 → 12/92	103			DJ720▲	EL890
405 1.8L TD Diesel					10/88 → 08/92		BR780 (Fibre), 1.65mm, 2 Notches -0.65 → 0.77mm BR790 (Fibre), 1.80mm, 3 Notches (30-026855-10) -0.77 → 0.82mm		(21-25202-22/0)	(22-25198-01/0) GJ720▲ (20-25202-02/0)
XUD7TE (AJZ)	1769	4	80.00			44/66/ 60/90				
XUD7TE (A8A)	1769	4	80.00			66/90				
405 1.9L					07/87 → 12/93	104			DN590▲	EL650
405 1.9L 4x4					07/88 → 12/92		BL650 (Fibre), 1.20mm (30-026859-10) BR510 (Fibre), 1.44mm [34] (30-026858-10)		(21-25204-21/0)	(22-25198-00/0) GL650
405 1.9L Injection					07/87 → 12/92					
XU92C (D2A/D2C/D2D)	1905	4		Carburettor		93/126				
XU911 (DFZ)/XU9JAZ (DKZ)	1905	4	83.00	MPi		70/95				
XU9M (DDZ)	1905	4	83.00	SPi		90/122				
405 1.9L D Diesel					03/88 → 10/96	105			DJ720▲	EL890
XUD9 (DJZ/D9A/162)	1905	4	83.00			47/64	BX880 (Fibre), 1.36mm, 1 Notch (30-028475-00) -0.56 → 0.67mm BX890 (Fibre), 1.40mm, 2 Notches (30-028476-00) -0.68 → 0.71mm BX900 (Fibre), 1.44mm, 3 Notches (30-028477-00) -0.72 → 0.75mm BX910 (Fibre), 1.48mm, 4 Notches (30-028478-00) -0.76 → 0.79mm BX920 (Fibre), 1.52mm, 5 Notches (30-028479-00) -0.80 → 0.83mm		(21-25202-22/0)	(22-25198-01/0) GJ720▲ (20-25202-02/0)
XUD9A (D9B/DJY/DJZ)/XUD9A (DJY/D9B)	1905	4	83.00			51/69				
405 1.9L Sport MI-16					07/87 → 12/92	106			DF180■○	EL650
405 1.9L Sport MI-16 4x4					04/88 → 12/92		BR510 (Fibre), 1.44mm [34] (30-026858-10)		DR510	(22-25198-00/0)
XU914 (DFW)	1905	4	83.00	MPi		90/122				
XU914 (D6C/DFW)	1905	4	83.00	MPi		116/158				

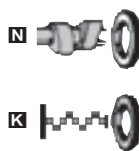
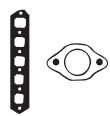

BL650



BR780, BR790



BX880, BX890,
BX900, BX910,
BX920



JC415



JC750



JC759



JC991



JD519



JD520



JN544

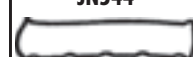

JN547



JP043

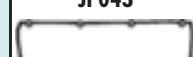

JP044



JJ283



HBS038 [22-15003B]
M11x1.50x175mm (x10)
→Eng.07448

HBS083 [22-15002B]
M11x1.50x168mm (x10)

HBS260 [22-53011B]
M11x1.50x168mm (x10)
Eng.07448 →

JD519 (x2)
JD520 (x4)

JP043
(50-028759-00)

JJ283 [6]
(31-025198-10)
● **PA349**
(33-102290-10)
22x16x2mm
● **PB907**
14x21x2mm

HR569 [24-30667-00/0]

NF817 36x50x7mm, FPM
(50-319112-00)
NA5191 42x62x7mm, PTFE
(50-319500-00)
NA5192 90x110x7mm, PTFE
(50-319501-00)

HL5019 [245] [5]
HR566 [37] [5]
NF836 [38] [4]
NF826 [38] [2]
KA611 [13]

HBS084 [22-15005B]
M12x1.50x123mm (x10)

JC759 [60]
(31-028417-00)
(Steel)
→12/90
JC991
(31-028595-00)
01/91 →

JN544
(50-025202-00)

JJ283 [6]
(31-025198-10)
● **PA349**
(33-102290-10)
22x16x2mm
● **PB907**
14x21x2mm

HR569 [24-30667-00/0]

NB959 35x50x7mm, FPM
(50-306644-50)
NF841 35x50x8mm, FPM
(50-319310-00)
NA5191 42x62x7mm, PTFE
(50-319500-00)
NA5192 90x110x7mm, PTFE
(50-319501-00)

HL5010 [245] [5]
HL5012 [245] [5]
NF836 [38] [4]
NF826 [38] [2]
KA611 [13]

HBS038 [22-15003B]
M11x1.50x175mm (x10)

HBS083 [22-15002B]
M11x1.50x168mm (x10)

JC750 [60]
JC415 (x4)
(31-025205-20)

JN547
(50-025204-10)

JJ283 [6]
(31-025198-10)
● **PA349**
(33-102290-10)
22x16x2mm
● **PB907**
14x21x2mm

HR569 [24-30667-00/0]

NF817 36x50x7mm, FPM
(50-319112-00)
NA5191 42x62x7mm, PTFE
(50-319500-00)
NA5192 90x110x7mm, PTFE
(50-319501-00)

HL5019 [245] [5]
HR566 [37] [5]
NF836 [38] [4]
NF826 [38] [2]
KA611 [13]

HBS084 [22-15005B]
M12x1.50x123mm (x10)

JC759 [60]
(31-028417-00)
(Steel)

JN544
(50-025202-00)

JJ283 [6]
(31-025198-10)
● **PA349**
(33-102290-10)
22x16x2mm
● **PB907**
14x21x2mm

HR569 [24-30667-00/0]

NF841 35x50x8mm, FPM
(50-319310-00)
→12/93
NB959 35x50x7mm, FPM
(50-306644-50)
01/94 →
NA5191 42x62x7mm, PTFE
(50-319500-00)
NA5192 90x110x7mm, PTFE
(50-319501-00)

HL5010 [245] [5]
HL5012 [245] [5]
NF836 [38] [4]
NF826 [38] [2]
KA611 [13]

HBS038 [22-15003B]
M11x1.50x175mm (x10)

JD5763 (x2)
JD5764

JP044
(50-028763-00)

JJ283 [6]
(31-025198-10)
● **PA349**
(33-102290-10)
22x16x2mm

HR642 (x2)

NF817 (x2) 36x50x7mm, FPM
(50-319112-00)
NF869 (x2) 32x45x8mm, MVQ
NA5191 42x62x7mm, PTFE
(50-319500-00)
NA5192 90x110x7mm, PTFE
(50-319501-00)







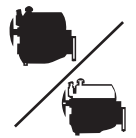



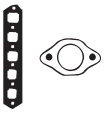

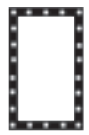

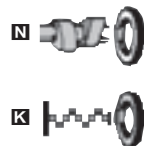

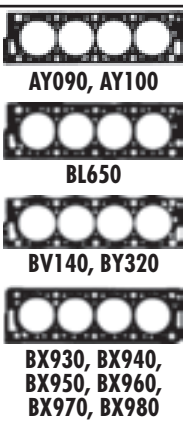























































HL5019 [245] [5]
HR566 [37] [5]
NF836 [38] [4]
NF826 [38] [2]
KA611 [13]
LC292 (x2) [14]



KW/PS



405 1.9L TD Diesel				08/92 → 10/96	107	BX930 (Steel Elastomer), 1.36mm, 1 Notch (30-028503-00) BX940 (Steel Elastomer), 1.40mm, 2 Notches (30-028504-00) BX950 (Steel Elastomer), 1.44mm, 3 Notches (30-028505-00) BX960 (Steel Elastomer), 1.48mm, 4 Notches (30-028506-00) BX970 (Steel Elastomer), 1.52mm, 5 Notches (30-028507-00) BX980 (Steel Elastomer), 1.59mm ↳0.83mm→	DJ720▲	EL890 (22-25198-01/0) GJ720▲ (20-25202-02/0)
XUD9TE (DHX/DHY/D8A)	1905	4	83.00		66/89			
405 2.0L				08/92 → 10/96	108	BV140 (Fibre), 1.25mm (30-028760-00) BY320 (Fibre), 1.45mm [34]	CY080▲	ES820 (22-25198-03/0)
XU10J2 (RFX)	1998	4	86.00	MPi	89-96/ 121- 131			
405 2.0L 4x4				08/92 → 10/96	109	AY090 (Fibre), 1.25mm (30-028762-00) AY100 (Fibre), 1.45mm [34]	CY090▲	ES820 (22-25198-03/0)
XU10J4 (RFT)	1998	4	86.00	MPi				
405 2.0L X4				08/92 → 10/95	110	AY090 (Fibre), 1.25mm (30-028762-00) AY100 (Fibre), 1.45mm [34]	CY090▲	ES820 (22-25198-03/0)
XU10J4 (RFT/RFY)	1998	4	86.00	MPi				
405 2.0L T 16 X4				08/92 → 10/95	111	BL650 (Fibre), 1.20mm (30-026859-10) BR510 (Fibre), 1.44mm [34] (30-026858-10)	CY130▲	EL650 (22-25198-00/0)
XU10J4TE (RGZ)	1998	4	86.00					
406 1.6L				11/95 → 05/04	112	AD5310 (MLS), 0.75mm	CD5310	ED5300
XU5JP (BFZ)	1580	4	83.00	MPi				
406 1.8L 16V				10/00 → 10/04	113	AD5100 (Fibre)	CD5100	→Eng.7965
EW7J4 (6FZ)	1749	4	82.70	MPi				
406 1.8L 16V				11/95 → 10/00				
XU7JP4 (LFY)	1761	4	83.00	MPi	81/110			

								
HBS088  (22-15014B) M12x1.50x145mm (x10) →Eng.08574 HBS277  (22-53018B) M12x1.50x148mm (x10) Eng.08575 →	JC759 [60] (31-028417-00) (Steel) JC991 (31-028595-00) US87 & CEE19-5 JC423  (x2) (31-025199-10)	JN544 (50-025202-00)	JJ283 [6] (31-025198-10) PA349 (33-102290-10) 22x16x2mm PB907 14x21x2mm	HR569  24-30667-00/0	NB959 35x50x7mm, FPM (50-306644-50) NF841 35x50x8mm, FPM (50-319310-00) NA5191  42x62x7mm, PTFE (50-319500-00) NA5192  90x110x7mm, PTFE (50-319501-00)	HL5010 [245]  HL5012 [245]  NF836 [38]  NF826 [38]  KA611 [13]	AY090, AY100 BL650 BV140, BY320 BX930, BX940, BX950, BX960, BX970, BX980 HA510 JC423 JC759 JC991 JD519 JD520 JD536 JN544 JP043 JP044 JJ283	
HBS084  (22-15005B) M12x1.50x123mm (x10)	HA510  JD520  (x4)	JP043 (50-028759-00)	JJ283 [6] (31-025198-10) PA349 (33-102290-10) 22x16x2mm PB907 14x21x2mm	HR569  24-30667-00/0	NF817 36x50x7mm, FPM (50-319112-00) NA5191  42x62x7mm, PTFE (50-319500-00) NA5192  90x110x7mm, PTFE (50-319501-00)	HL5019 [245]  NF836 [38]  NF826 [38]  KA611 [13]	HA510 JC423 JC759 JC991 JD519 JD520 JD536 JN544 JP043 JP044 JJ283	
HBS087  (22-15013B) M12x1.50x110mm (x10) →Eng.08581 HBS278  (22-53019B) M12x1.50x110mm (x10) Eng.08582 →	JD536 	JP044 (50-028763-00)	JJ283 [6] (31-025198-10) PA349 (33-102290-10) 22x16x2mm PB907 14x21x2mm	HR642  (x2)	NF817 (x2) 36x50x7mm, FPM (50-319112-00) NA5191  42x62x7mm, PTFE (50-319500-00) NA5192  90x110x7mm, PTFE (50-319501-00)	HL5019 [245]  NF836 [38]  NF826 [38]  KA611 [13] XU1014RS	HA510 JC423 JC759 JC991 JD519 JD520 JD536 JN544 JP043 JP044 JJ283	
HBS087  (22-15013B) M12x1.50x110mm (x10) →Eng.08581 HBS278  (22-53019B) M12x1.50x110mm (x10) Eng.08582 →	JD536 	JP044 (50-028763-00)	JJ283 [6] (31-025198-10) PA349 (33-102290-10) 22x16x2mm PB907 14x21x2mm	HR642  (x2)	NF817 (x2) 36x50x7mm, FPM (50-319112-00) NA5191  42x62x7mm, PTFE (50-319500-00) NA5192  90x110x7mm, PTFE (50-319501-00)	HL5019 [245]  NF824 [38]  NF836 [38]  KA611 [13] XU1014RS	HA510 JC423 JC759 JC991 JD519 JD520 JD536 JN544 JP043 JP044 JJ283	
HBS038  (22-15003B) M11x1.50x175mm (x10) →Eng.07448 HBS083  (22-15002B) M11x1.50x168mm (x10) HBS260  (22-53011B) M11x1.50x168mm (x10) Eng.07448 →	JD519  (x2) JD520  (x4)	JP043 (50-028759-00)	JJ283 [6] (31-025198-10) PA349 (33-102290-10) 22x16x2mm PB907 14x21x2mm	HR569  24-30667-00/0	NF817 36x50x7mm, FPM (50-319112-00) NA5191  42x62x7mm, PTFE (50-319500-00) NA5192  90x110x7mm, PTFE (50-319501-00)	HL5019 [245]  HR566 [37]  NA5205 [38]  NA5204 [38]  KA611 [13]	HA510 JC423 JC759 JC991 JD519 JD520 JD536 JN544 JP043 JP044 JJ283	
HBS259  (22-53010B) M11x1.50x144.5mm (x10)	JD5833 	JM5283  JM5139 	PB907 14x21x2mm		NA5256  40x55x6.5mm			
HBS089  (22-15016B) M11x1.50x159mm (x10)	JD536  JD5832 		PB907 14x21x2mm	HR5080  (24-30710-45/0) →Eng.07359 HR5081  (24-30721-87/0) Eng.07360 → →Eng.07965	NF817 36x50x7mm, FPM (50-319112-00) NA5191  42x62x7mm, PTFE (50-319500-00) NA5192  90x110x7mm, PTFE (50-319501-00)	HL5019 [245]  HR566 [37]  NA5205 [38]  NA5204 [38]  KA611 [13]		



KW/PS

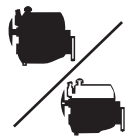

406 1.9L D Diesel				10/96 → 10/04		114	BX930 (Steel Elastomer), 1.36mm, 1 Notch (30-028503-00) BX940 (Steel Elastomer), 1.40mm, 2 Notches (30-028504-00) BX950 (Steel Elastomer), 1.44mm, 3 Notches (30-028505-00) BX960 (Steel Elastomer), 1.48mm, 4 Notches (30-028506-00) BX970 (Steel Elastomer), 1.52mm, 5 Notches (30-028507-00) BX980 (Steel Elastomer), 1.59mm →-0.83mm →	DJ720▲ (21-25202-22/0)	EL890 (22-25198-01/0) GJ720▲ (20-25202-02/0)
XUD9SD (DHW)	1905	4	83.00		66/89				
406 1.9L TD Diesel				01/96 → 10/04		115	BX930 (Steel Elastomer), 1.36mm, 1 Notch (30-028503-00) BX940 (Steel Elastomer), 1.40mm, 2 Notches (30-028504-00) BX950 (Steel Elastomer), 1.44mm, 3 Notches (30-028505-00) BX960 (Steel Elastomer), 1.48mm, 4 Notches (30-028506-00) BX970 (Steel Elastomer), 1.52mm, 5 Notches (30-028507-00) BX980 (Steel Elastomer), 1.59mm →-0.83mm →	DJ720▲ (21-25202-22/0)	EL890 (22-25198-01/0) GJ720▲ (20-25202-02/0)
XUD9TE (DHX) / XUD9TE (DHX/DHY/D8A)	1905	4	83.00		66/89				
406 2.0L 16V				01/99 → 10/04		116	AD5300 (MLS)	CD5300	ED5300
406 2.0L 16V HPi				05/01 → 10/04					
406 Coupe 2.0L 16V				01/99 → 12/04					
EW10J4 (RFR)	1997	4	85.00	Injection, DOHC	99/135				
EW10J4 (RFN)	1997	4	85.00	MPi, DOHC	100/136				
EW10D (RLZ)	1997	4	85.00	Injection, DOHC	103/140				
406 2.0L 16V				11/95 → 10/04		117	AY070 (Fibre) (30-029744-00)		
406 Coupe 2.0L 16V				03/97 → 12/04					
XU10J4R (RFV/R6E)	1998	4	86.00	MPi	99/135				
406 2.0L HDI 110 Diesel				06/98 → 04/04		118	AC5011 (MLS), 1.30mm, 1 Hole →-0.47 → -0.605mm AC5031 (MLS), 1.40mm, 3 Holes (30-029479-10) →-0.655 → -0.705mm AC5051 (MLS), 1.50mm, 5 Holes (30-029481-10) →-0.755 → -0.83mm	CC5010▲ (21-29484-20/0) →Eng.8331 CC5011▲ Eng.8332 →	EA5830
DW10ATED (RHZ)	1997	4	85.00	Common Rail	80/109				
406 2.0L HDI 110 FAP Diesel				08/01 → 10/04		119	AD5490 (MLS), 1.25mm (30-029789-00) AD5500 (MLS), 1.30mm (30-029790-00) AD5510 (MLS), 1.35mm (30-029791-00) AD5520 (MLS), 1.40mm (30-029792-00)	CC5010▲ (21-29484-20/0) →Eng.8331 CC5011▲ Eng.8332 →	EA5830
DW10ATED (RHZ)	1997	4	85.00	Common Rail	80/109				
DW10ATED (RHS)	1997	4	85.00	Common Rail, DOHC	81/110				

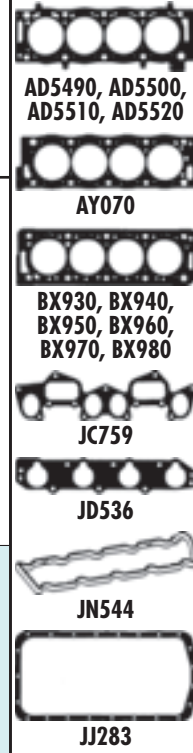
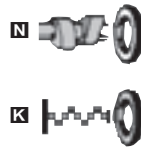
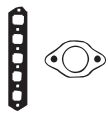









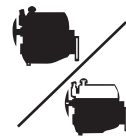



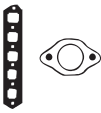

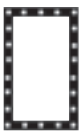

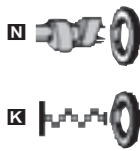



































































HBS084 [6] <i>(22-15005B)</i> M12x1.50x123mm (x10)	JC759 [60] <i>(31-028417-00)</i> (Steel) ECR EN95LS	JN544 <i>(50-025202-00)</i>	JJ283 [6] <i>(31-025198-10)</i> PA349 <i>(33-102290-10)</i> 22x16x2mm PB907 14x21x2mm	HR569 [5] 24-30667-00/0	NA959 35x50x7mm, FPM <i>(50-306644-50)</i> NF841 35x50x8mm, FPM <i>(50-319310-00)</i> NA5191 42x62x7mm, PTFE <i>(50-319500-00)</i> NA5192 90x110x7mm, PTFE <i>(50-319501-00)</i>	HL5010 [245] [5] HL5012 [245] [5] NF836 [38] [4] NF826 [38] [2] ZX, Xantia, Xsara KA611 [13]
HBS088 [6] <i>(22-15014B)</i> M12x1.50x145mm (x10) →Eng.08574 HBS277 [6] <i>(22-53018B)</i> M12x1.50x148mm (x10) Eng.08575→	JC759 [60] <i>(31-028417-00)</i> (Steel)	JN544 <i>(50-025202-00)</i>	JJ283 [6] <i>(31-025198-10)</i> PA349 <i>(33-102290-10)</i> 22x16x2mm PB907 14x21x2mm	HR569 [5] 24-30667-00/0	NA959 35x50x7mm, FPM <i>(50-306644-50)</i> NA5191 42x62x7mm, PTFE <i>(50-319500-00)</i> NA5192 90x110x7mm, PTFE <i>(50-319501-00)</i>	HL5012 [245] [5] NA5205 [38] [4] NA5204 [38] [2] KA611 [13]
HBS259 [6] <i>(22-53010B)</i> M11x1.50x144.5mm (x10)	JD5833 [1]	JM5283 [1] JM5139 [1]	PB907 14x21x2mm		NA5256 [1] 40x55x6.5mm	
HBS087 [6] <i>(22-15013B)</i> M12x1.50x110mm (x10) →Eng.08581 HBS278 [6] <i>(22-53019B)</i> M12x1.50x110mm (x10) Eng.08582→	JD536 [1] →Eng.07328		PB907 14x21x2mm	HR5080 [5] <i>(24-30710-45/0)</i> →Eng.07359 HR5081 [5] <i>(24-30721-87/0)</i> Eng.07360→ →Eng.07965	NF817 (x2) 36x50x7mm, FPM <i>(50-319112-00)</i> NA5191 42x62x7mm, PTFE <i>(50-319500-00)</i> NA5192 90x110x7mm, PTFE <i>(50-319501-00)</i>	HL5019 [245] [5] NA5205 [38] [4] NA5204 [38] [2] KA611 [13]
HBS261 [6] <i>(22-53014B)</i> M12x1.50x131mm (x10)	JD5191 [1] JD5190 [1]	JM5087	KG5157 10x20x2mm PB907 14x21x2mm	HR5046 [5] (x2)	NA5035 27x47x7mm, FPM <i>(50-319474-00)</i> NA5191 42x62x7mm, PTFE <i>(50-319500-00)</i> NA5192 90x110x7mm, PTFE <i>(50-319501-00)</i>	HL5016 [245] [5] NA5205 [38] [4] NA5204 [38] [2]
HBS261 [6] <i>(22-53014B)</i> M12x1.50x131mm (x10)		JM5141 <i>(50-030271-00)</i>	KG5157 10x20x2mm PB907 14x21x2mm	HR5046 [5] (x2)	NA5035 27x47x7mm, FPM <i>(50-319474-00)</i> NA5191 42x62x7mm, PTFE <i>(50-319500-00)</i> NA5192 90x110x7mm, PTFE <i>(50-319501-00)</i>	HL5016 [245] [5] NA5205 [38] [4] NA5204 [38] [2]

PEUGEOT



KW/PS









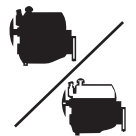



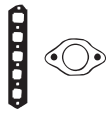

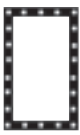

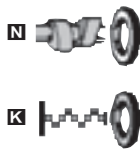

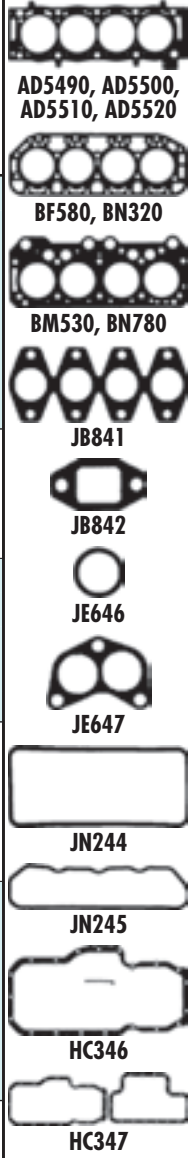





































































								 AD5130, AD5140, AD5150, AD5160, AD5170
HBS261  (22-53014B) M12x1.50x131mm (x10)	JD5191  JD5190 	JM5087	KG5157 10x20x2mm PB907 14x21x2mm	HR5046  (x2)	NA5035 27x47x7mm, FPM (50-319474-00) NA5191  42x62x7mm, PTFE (50-319500-00) NA5192  90x110x7mm, PTFE (50-319501-00)	HL5016 [245]  NA5205 [38]  NA5204 [38] 	 AD5490, AD5500, AD5510, AD5520  BY310, BY320	
HBS084  (22-15005B) M12x1.50x123mm (x10)	HA512  	JN547 (50-025204-10)	JJ283 [6] (31-025198-10) PA349 (33-102290-10) 22x16x2mm PB907 14x21x2mm	HR569  24-30667-00/0	NF817 36x50x7mm, FPM (50-319112-00) NA5191  42x62x7mm, PTFE (50-319500-00) NA5192  90x110x7mm, PTFE (50-319501-00)	HL5019 [245]  NA5205 [38]  NA5204 [38]  KA611 [13]	 HA512  JD230  JD529	
HBS125  (22-15007B) M12x1.50x150.5mm (x10)	JD529  (31-027540-00) JD230 	JP045 (50-028922-00)	PB907 14x21x2mm	HR805 	NF841 35x50x8mm, FPM (50-319310-00) NA5191  42x62x7mm, PTFE (50-319500-00) NA5192  90x110x7mm, PTFE (50-319501-00)	HL5010 [245]  NA5205 [38]  NA5204 [38]  KA611 [13]	 JN547  JP045  JJ283	
HBS309  (22-53020B) M11x1.50x128mm (x10)	JD5883  Soft Material Gasket	JM5283  JM5139 	PB907 14x21x2mm		NA5256  40x55x6.5mm			
HBS261  (22-53014B) M12x1.50x131mm (x10)		JM5141 (50-030271-00)	KG5157 10x20x2mm PB907 14x21x2mm	HR5046  (x2)	NA5035 27x47x7mm, FPM (50-319474-00) NA5191  42x62x7mm, PTFE (50-319500-00) NA5192  90x110x7mm, PTFE (50-319501-00)	HL5016 [245]  NA5205 [38]  NA5204 [38] 		
HBS272  (22-53016B) M10x1.50x147mm (x16)	JD5879  JD5880  (Steel Elastomer) JD5878  (MLS)		PB852 16x24x1.5mm	HR5062  24-30614-73/0	NA5260 38x50x6mm			
HBS272  (22-53016B) M10x1.50x147mm (x16)	JD5906  JD5907  (x2)  JE5069  JE5070  JE5071		PB852 16x24x1.5mm	HR5062  24-30614-73/0	NA5260 38x50x6mm			
HBS359  (22-15018B) M11x1.50x150mm (x10)	JD5830   (50-030266-00) HA5031    (24-35043-00/0) HA5030    (24-35042-90/0) JD5829  (31-030265-00)	JM7034 (50-030264-00)	KG5157 10x20x2mm		NA5258 27x47x7mm NA5259  40x55x6.4mm	HL5033 [245] 		
HBS259  (22-53010B) M11x1.50x144.5mm (x10)	JD5833 	JM5283  JM5139 	PB907 14x21x2mm		NA5256  40x55x6.5mm			



KW/PS



407 Coupe 2.0L HDI Diesel		10/05 →		129		AD5490 (MLS), 1.25mm (30-029789-00)		CD5500▲	ED5500
407 2.0L HDI 135 FAP Diesel		05/04 →		130		AD5500 (MLS), 1.30mm (30-029790-00)			
407 2.0L HDI 16V Diesel		09/05 →		131		AD5510 (MLS), 1.35mm (30-029791-00)			
407 Coupe 2.2L		10/05 →		132		AD5520 (MLS), 1.40mm (30-029792-00)			
407 2.0L		05/04 →		133		AG9750 (MLS)		CG9750	EG9750
407 2.0L 16V		09/05 →		134		AH5060 (MLS), 0.74mm ☒		CH5060☒	
407 2.2L		05/04 →		135		AH5070 (MLS), 0.95mm ☒		CH5040☒	
407 2.2L 16V		09/05 →		136		AH5040 (MLS), 0.74mm ☒			
407 Coupe 2.2L		10/05 →		137		AH5050 (MLS), 0.95mm ☒			
407 3.0L		05/04 →		138				DM710○	GM710■○ [36]
407 3.0L V6		10/05 →		139					
504 1.8L		01/71 → 12/89		140					
504 1.9L D Diesel		03/73 → 12/89		141		BF580 (Fibre), 1.40mm [22] Eng.2053777 →		DG050▲■	EF580
504 2.0L		10/74 → 08/84		142		BN320 (Fibre), 1.58mm, 1 Notch [22] Eng.2053777 →		[21-24586-24/0]	GF322 [63]
504 2.0L TI		01/71 → 06/83		143				DF580 [23]	→ Eng.2053776
504 Coupe 2.0L		08/82 → 08/84		144		BN780 (Fibre), 1.60mm [34]		[21-23775-21/0]	GF583 [23]
504 2.0L		03/71 → 07/86		145				Eng.2053777 →	GN320 [64]
504 2.1L D Diesel		02/71 → 07/86		146				Eng.2053777 →	Eng.2053777 →
504 2.0L		03/71 → 07/86		147		BM530 (Fibre), 1.40mm (30-025376-10)		DM530■	GM531○ [12]
504 2.1L D Diesel		02/71 → 07/86		148		BN780 (Fibre), 1.60mm [34]		DM533▲	
504 2.0L		03/71 → 07/86		149		BM530 (Fibre), 1.40mm (30-025376-10)		DM530■	GM533■○
504 2.1L D Diesel		02/71 → 07/86		150		BN780 (Fibre), 1.60mm [34]		DM533▲	
504 2.1L D Diesel		02/71 → 07/86		151		BF580 (Fibre), 1.40mm [22] Eng.1932463 →		DG050▲■	EF580
504 2.1L D Diesel		02/71 → 07/86		152		BN320 (Fibre), 1.58mm, 1 Notch [22] Eng.1932463 →		[21-24586-24/0]	GF322 [63]
504 2.1L D Diesel		02/71 → 07/86		153				DF580 [23]	→ Eng.1932462
504 2.1L D Diesel		02/71 → 07/86		154				[21-23775-21/0]	GF583 [23]
504 2.1L D Diesel		02/71 → 07/86		155				Eng.1932463 →	GN320 [64]
504 2.1L D Diesel		02/71 → 07/86		156				Eng.1932463 →	Eng.1932463 →

								
HBS261  (22-53014B) M12x1.50x131mm (x10)	JD5881 	HM5289 	● KG5157 10x20x2mm ● PB907 14x21x2mm	HR5046  (x2)	 NA5035 27x47x7mm, FPM (50-319474-00)  NA5191  42x62x7mm, PTFE (50-319500-00)  NA5192  90x110x7mm, PTFE (50-319501-00)	HL5016 [245]  NA5205 [38]  NA5204 [38] 	AD5490, AD5500, AD5510, AD5520 BF580, BN320 BM530, BN780 JB841 JB842 JE646 JE647 JN244 JN245 HC346 HC347	
HBS259  (22-53010B) M11x1.50x144.5mm (x10)	JD5833 	JM5283  JM5139 	● PB907 14x21x2mm		 NA5256  40x55x6.5mm	HL5037 [245] 		
HBS309  (22-53020B) M11x1.50x128mm (x10)	JD5883  Soft Material Gasket	JM5283  JM5139 	● PB907 14x21x2mm		 NA5256  40x55x6.5mm			
HBS272  (22-53016B) M10x1.50x147mm (x16)	JD5906  JD5907  (x2)  JE5069  JE5070  JE5071		● PB852 16x24x1.5mm	HR5062  24-30614-73/0				
HBS086  M11x1.50x179mm (x10) 06/85 → 04/89 HBS038  (22-15003B) M11x1.50x175mm (x10) 04/89 →	JB841  (31-018363-10)	JN244	● KJ647 18.3x24x2mm ● PA349 (33-102290-10) 22x16x2mm	HR569  24-30667-00/0		HL472 [37]  HR574 [37]  NF185 (x2) [2]   NF097 (x2) [38]		
	JB842  (x2)  JE646 (33-105030-10)	JN245 (50-024586-00)	HC346  ● PA349 (33-102290-10) 22x16x2mm	PA229 (x8) (50-324505-00)	 NF387  42x60x10mm, NBR (50-306429-00) → 08/85  NF780  45x60x7mm, ACM 09/85 →	NF185 (x2) [2]   NF097 (x2) [38] KA606 [13]		
HBS038  (22-15003B) M11x1.50x175mm (x10) HBS086  M11x1.50x179mm (x10)	JB841  (31-018363-10)  JE647 [47] (31-022193-10)	JN244	● PA349 (33-102290-10) 22x16x2mm	HR569  24-30667-00/0	 NF387  42x60x10mm, NBR (50-306429-00)	HL472 [37]  HR574 [37]  NF185 (x2) [2]  		
HBS038  (22-15003B) M11x1.50x175mm (x10) HBS086  M11x1.50x179mm (x10)	JB841  (31-018363-10)  JE647 [47] (31-022193-10)	JN244	● PA349 (33-102290-10) 22x16x2mm	HR569  24-30667-00/0	 NF387  42x60x10mm, NBR (50-306429-00)	HL472 [37]  HR574 [37]  NF185 (x2) [2]   NF097 (x2) [38] LT832 [46]		
	JB842  (x2)	JN245 (50-024586-00)	HC347  ● PA349 (33-102290-10) 22x16x2mm	PA229 (x8) (50-324505-00)	 NF387  42x60x10mm, NBR (50-306429-00) → 08/85  NF780  45x60x7mm, ACM 09/85 →	NF185 (x2) [2]   NF097 (x2) [38] KA606 [13]		











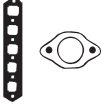

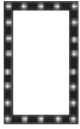

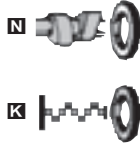

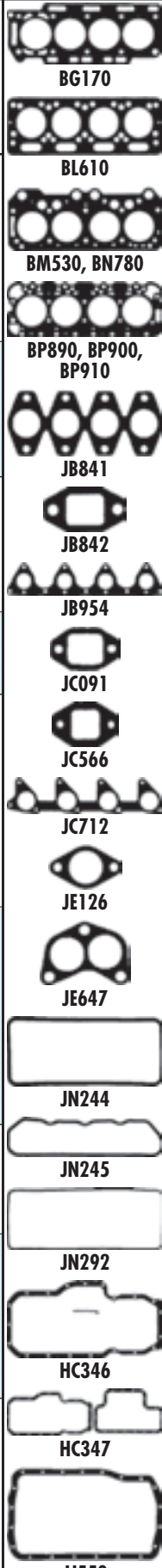

























































PEUGEOT



KW/PS



504 2.3L D Diesel				07/75 → 12/89	138			DG050▲■ (21-24586-24/0)	EH890 GG050▲○
XD2 (134)	2304	4	94.00		51/69	BP890 (Fibre), 1.53mm, 2 Notches (30-026144-10) BP900 (Fibre), 1.63mm, 3 Notches (30-026145-10) BP910 (Fibre), 1.73mm, 4 Notches (30-026146-10) 05/80 →			
505 1.8L				06/81 → 10/86	139			DM710○	GM710■○ [36]
XM7 (105)	1796	4	84.00	Carburettor	55-60/ 75-82				
XM7A (105C)	1796	4	84.00	Carburettor	62-66/ 90-90				
505 2.0L				09/80 → 09/91	140			DM530■ DM533▲	GM533■○
XN1 (106)/XN1A (106E)	1971	4			60/82	BM530 (Fibre), 1.40mm (30-025376-10)			
	1971	4			79/107	BN780 (Fibre), 1.60mm [34]			
	1971	4	88.00	Carburettor	57/77				
505 2.0L Export				01/83 → 12/86	141			DM530■ DM533▲	GM531○ [12]
XN6	1971	4	88.00	SPi		BM530 (Fibre), 1.40mm (30-025376-10) BN780 (Fibre), 1.60mm [34]			
505 2.0L TI,STI				08/79 → 10/86	142			DG171○	
ZEJ (829)	1995	4	88.00	MPi	81/110	BG170 (Fibre), 1.20mm (30-027064-10)			
505 2.2L				05/81 → 12/93	143			DG171○	
505 2.2L GTI				08/83 → 12/93		BG170 (Fibre), 1.20mm (30-027064-10)			
ZDJL (851X)	2165	4		Carburettor	96/130				
ZDJ (851)	2165	4	88.00	MPi	84/114				
ZDJL (851B)	2165	4	88.00	Injection	85/115 90/122				
505 2.2L T Injection				03/84 → 12/88	144				GL610○
N9TE (176X)	2155	4	91.70		110/150	BL610 (Fibre), 1.35mm			
N9TE (176B)	2155	4	91.70		114/155				
N9T	2155	4	91.70		128/174				
505 2.3L D Diesel				04/82 → 06/86	145			DG052▲ (21-24586-25/0)	EH890 GG052▲○ (20-24586-04/0)
505 2.3L TD Diesel				09/80 → 06/86					
XD2S (147)	2304	4	94.00		59/80	BP890 (Fibre), 1.53mm, 2 Notches (30-026144-10) BP900 (Fibre), 1.63mm, 3 Notches (30-026145-10) BP910 (Fibre), 1.73mm, 4 Notches (30-026146-10)			
505 2.5L D Diesel				06/81 → 12/93	146			DH890▲■	EH890 GH890▲○ (20-24586-05/0)
XD3 (155)	2498	4	94.00		51-55/ 70-75	BP890 (Fibre), 1.53mm, 2 Notches (30-026144-10) BP900 (Fibre), 1.63mm, 3 Notches (30-026145-10) BP910 (Fibre), 1.73mm, 4 Notches (30-026146-10)			











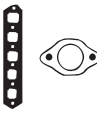



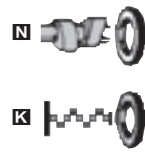







































































































								
HBS015  (22-53004B) M11x1.50x97.5mm (x8) M11x1.50x120mm (x7) M11x1.50x107.5mm (x7)	JB842  (x2)	JN245 (50-024586-00)	HC347  ● PA349 (33-102290-10) 22x16x2mm	PA229 (x8) (50-324505-00)	 NF387  42x60x10mm, NBR (50-306429-00)	NF097 (x2) [38] KA606 [13] NF334 [42]	BG170 BL610 BM530, BN780 BP890, BP900, BP910 JB841 JB842 JB954 JC091 JC566 JC712 JE126 JE647 JN244 JN245 JN292 HC346 HC347 JJ558	
HBS038  (22-15003B) M11x1.50x175mm (x10) HBS086  M11x1.50x179mm (x10)	JB841  (31-018363-10) ● JE647 [47] (31-022193-10) → Eng.1717000	JN244	● KJ647 18.3x24x2mm ● PA349 (33-102290-10) 22x16x2mm	HR569  24-30667-00/0	 NF387  42x60x10mm, NBR (50-306429-00)	HL472 [37]  HR574 [37]  NF097 (x2) [38] LT832 [46]		
HBS038  (22-15003B) M11x1.50x175mm (x10) HBS086  M11x1.50x179mm (x10) → Eng.1807897	JB841  (31-018363-10) ● JE647 [47] (31-022193-10) → Eng.1807897	JN244	● PA349 (33-102290-10) 22x16x2mm	HR569  24-30667-00/0	 NF387  42x60x10mm, NBR (50-306429-00)	HL472 [37]  HR574 [37]  NF097 (x2) [38] LT832 [46]		
HBS086  M11x1.50x179mm (x10) 06/85→	JB841  (31-018363-10)	JN244	● PA349 (33-102290-10) 22x16x2mm	HR300  HR569  24-30667-00/0		HL472 [37]  HR574 [37]  NF097 (x2) [38]		
HBS116  (22-51006B) M12x1.50x243mm (x10)	JB954 	JN292 (50-024771-00)	JJ558 (Felt) ● PA349 (33-102290-10) 22x16x2mm	HR569  24-30667-00/0	 NA5016 35x47x7mm, FPM/ACM (50-305690-50)  NF687 35x47x7mm, ACM (50-306251-00)  NF648  50x68x10mm, MVQ (50-306251-00)  NF843  50x68x10mm, FPM/ACM (50-305667-70)  NF844  90x110x11mm, FPM/ACM	HL5014 [245]  NF097 (x2) [38] NF849 [15]		
HBS302  (22-51106B) M12x1.50x204mm (x10)	JB954 	JN292 (50-024771-00)	JJ558 (Felt) ● PA349 (33-102290-10) 22x16x2mm	HR569  24-30667-00/0	 NA5016 35x47x7mm, FPM/ACM (50-305690-50)  NF687 35x47x7mm, ACM (50-306251-00)  NF648  50x68x10mm, MVQ (50-306251-00)  NF843  50x68x10mm, FPM/ACM (50-305667-70)  NF844  90x110x11mm, FPM/ACM	HL5014 [245]  NF097 (x2) [38] NF849 [15]		
	JC712 					NF097 (x2) [38]		
HBS015  (22-53004B) M11x1.50x97.5mm (x8) M11x1.50x120mm (x7) M11x1.50x107.5mm (x7)	JC091  (x2) (31-026150-10)	JN245 (50-024586-00)	HC346  ● PA349 (33-102290-10) 22x16x2mm	PA229 (x8) (50-324505-00)	 NF387  42x60x10mm, NBR (50-306429-00) → 10/83  NF780  45x60x7mm, ACM 10/83→	NF097 (x2) [38] KA606 [13]		
HBS015  (22-53004B) M11x1.50x97.5mm (x8) M11x1.50x120mm (x7) M11x1.50x107.5mm (x7) HBS016  (22-53005B) M11x1.50x120mm (x7) M11x1.50x107.5mm (x15)	JC566  (x2) ● JE126 (32-202265-10)	JN245 (50-024586-00)	HC346  ● PA349 (33-102290-10) 22x16x2mm		 NF780  45x60x7mm, ACM  NF387  42x60x10mm, NBR (50-306429-00) → 12/85	NF097 (x2) [38] KA606 [13]		



KW/PS



505 2.5L TD Diesel				10/83 → 12/93	147	BP890 (Fibre), 1.53mm, 2 Notches (30-026144-10) BP900 (Fibre), 1.63mm, 3 Notches (30-026145-10) BP910 (Fibre), 1.73mm, 4 Notches (30-026146-10)	DG052▲ (21-24586-25/0)	GM310▲
CRD93L	2498	4	93.00	Indirect Injection	70/95			
XD3T (152A)	2498	4	94.00		66/89			
XD3TE (152B)	2498	4	94.00		77/105			
CRD93LS (U25/673)	2500	4	93.00		70/95			
505 2.8L GTI V6				06/86 → 12/93	148			
ZN3J (154X)	2849	6	91.00	SPi	105/ 114/ 125/ 143/ 155/ 170			
604 2.0L				01/83 → 12/86	149	BM530 (Fibre), 1.40mm (30-025376-10) BN780 (Fibre), 1.60mm [34]	DM530■ DM533▲	GM531○ [12]
XN6	1971	4	88.00	SPi				
604 2.3L TD Diesel				09/79 → 05/83	150	BP890 (Fibre), 1.53mm, 2 Notches (30-026144-10) BP900 (Fibre), 1.63mm, 3 Notches (30-026145-10) BP910 (Fibre), 1.73mm, 4 Notches (30-026146-10)	DG052▲ (21-24586-25/0)	EH890 GG052▲○ (20-24586-04/0)
XD2S (147)	2304	4	94.00		59/80			
604 2.5L TD Diesel				08/83 → 12/86	151	BP890 (Fibre), 1.53mm, 2 Notches (30-026144-10) BP900 (Fibre), 1.63mm, 3 Notches (30-026145-10) BP910 (Fibre), 1.73mm, 4 Notches (30-026146-10)	DG052▲ (21-24586-25/0)	GM310▲
XD3T (152A)	2498	4	94.00		66/89			
605 2.0L				06/89 → 09/99	152	BS820 (Fibre), 1.25mm (30-027556-00)	DS820▲ (21-25204-22/0)	ES820 (22-25198-03/0)
XU102C (R5A)	1998	4		Injection	79/107 84/114			
	1998	4	86.00					
605 2.0L				06/89 → 09/99	153	BS820 (Fibre), 1.25mm (30-027556-00)	DS820▲ (21-25204-22/0)	ES820 (22-25198-03/0)
XU10J2 (RFZ/R6A)	1998	4	86.00	MPi	89-90/ 121- 123			
605 2.0L 16V				07/94 → 09/99	154	AY070 (Fibre) (30-029744-00)		
XU10J4R (RFV/R6E)	1998	4	86.00	MPi	99/135			

								
HBS015  (22-53004B) M11x1.50x97.5mm (x8) M11x1.50x120mm (x7) M11x1.50x107.5mm (x7) →09/87 HBS016  (22-53005B) M11x1.50x120mm (x7) M11x1.50x107.5mm (x15) 09/87→		JN245 (50-024586-00)	HC346  PA349 (33-102290-10) 22x16x2mm	PA229 (x8) (50-324505-00)	NF780  45x60x7mm, ACM	NF097 (x2) [38] KA606 [13]	 AY070  BM530, BN780  BP890, BP900, BP910  BS820  JB841  JC091  JC415  JD536  JD539  JN244  JN245  JN547  HC346  JJ283	
HBS127  (22-15009B) M12x1.50x178mm (x16)			PA349 (33-102290-10) 22x16x2mm	HR805  →Eng.1889 HR569  24-30667-00/0 Eng.1890→	NF761  42x62x10mm, FPM/ACM (50-319355-00) NF634  80x100x13mm, MVQ (50-319343-00)	NF097 (x2) [38]	 JB841  JC091  JC415  JD536  JD539  JN244  JN245  JN547  HC346  JJ283	
HBS086  M11x1.50x179mm (x10) 06/85→	JB841  (31-018363-10)	JN244	PA349 (33-102290-10) 22x16x2mm	HR300  HR569  24-30667-00/0		HL472 [37]  HR574 [37]  NF097 (x2) [38]	 JB841  JC091  JC415  JD536  JD539  JN244  JN245  JN547  HC346  JJ283	
HBS015  (22-53004B) M11x1.50x97.5mm (x8) M11x1.50x120mm (x7) M11x1.50x107.5mm (x7)	JC091  (x2) (31-026150-10)	JN245 (50-024586-00)	HC346  PA349 (33-102290-10) 22x16x2mm	PA229 (x8) (50-324505-00)	NF387  42x60x10mm, NBR (50-306429-00)	NF097 (x2) [38] KA606 [13]	 JN244  JN245  JN547  HC346  JJ283	
HBS015  (22-53004B) M11x1.50x97.5mm (x8) M11x1.50x120mm (x7) M11x1.50x107.5mm (x7) →08/87 HBS016  (22-53005B) M11x1.50x120mm (x7) M11x1.50x107.5mm (x15) 09/87→		JN245 (50-024586-00)	HC346  PA349 (33-102290-10) 22x16x2mm	PA229 (x8) (50-324505-00)	NF780  45x60x7mm, ACM	NF097 (x2) [38] KA606 [13]	 JN244  JN245  JN547  HC346  JJ283	
HBS084  (22-15005B) M12x1.50x123mm (x10)	JC415  (x4) (31-025205-20)	JN547 (50-025204-10)	JJ283 [6] (31-025198-10) PA349 (33-102290-10) 22x16x2mm PB907 14x21x2mm	HR569  24-30667-00/0	NF817  36x50x7mm, FPM (50-319112-00) NA5191  42x62x7mm, PTFE (50-319500-00) NA5192  90x110x7mm, PTFE (50-319501-00)	HL5019 [245]  NF836 [38]  NF826 [38]  KA611 [13]	 JN244  JN245  JN547  HC346  JJ283	
HBS084  (22-15005B) M12x1.50x123mm (x10)	JC415  (x4) (31-025205-20)	JN547 (50-025204-10)	JJ283 [6] (31-025198-10) PA349 (33-102290-10) 22x16x2mm PB907 14x21x2mm	HR569  24-30667-00/0	NF817  36x50x7mm, FPM (50-319112-00) NA5191  42x62x7mm, PTFE (50-319500-00) NA5192  90x110x7mm, PTFE (50-319501-00)	HL5019 [245]  NF825 [38] [66] NF824 [38] [66]  NF836 [38] [67]  NF826 [38] [67]  KA611 [13]	 JN244  JN245  JN547  HC346  JJ283	
HBS087  (22-15013B) M12x1.50x110mm (x10) →Eng.08581 HBS278  (22-53019B) M12x1.50x110mm (x10) Eng.08582→	JD536  →Eng.07328 JD539 		PB907 14x21x2mm	HR5080  (24-30710-45/0) →Eng.07359 HR5081  (24-30721-87/0) Eng.07360→ →Eng.07965	NF817 (x2)  36x50x7mm, FPM (50-319112-00) NA5191  42x62x7mm, PTFE (50-319500-00) NA5192  90x110x7mm, PTFE (50-319501-00)	HL5019 [245]  NF825 [38] NF824 [38]  KA611 [13]	 JN244  JN245  JN547  HC346  JJ283	







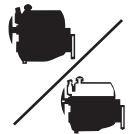



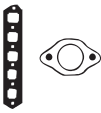

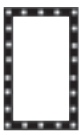

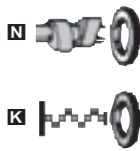

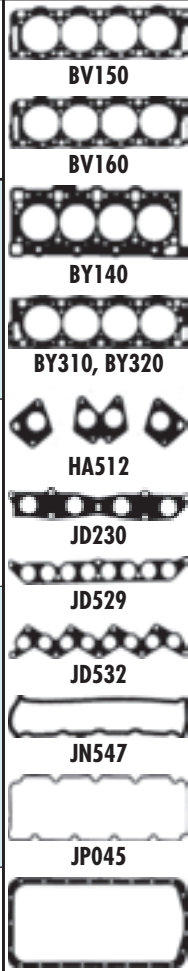

































































PEUGEOT



KW/PS



605 2.0L T				07/91 → 09/99		155			
XU10J2TE (RGY)	1998	4	86.00		104/141	BY310 (Fibre), 1.25mm (30-028761-00) BY320 (Fibre), 1.45mm [34]		DY310▲ (21-25204-25/0)	ES820 (22-25198-03/0)
XU10J2TE (RGX)	1998	4	86.00		108/147				
605 2.1L D Diesel				06/89 → 07/95		156			
XUD11A (P9A/PJZ)	2138	4	86.00		61/82	BV150 (Fibre), 1.58mm, 2 Notches ☞0.65 → 0.77mm BV160 (Fibre), 1.70mm, 3 Notches (30-027546-00) ☞0.77 → 0.82mm		DV150▲ (21-27540-20/0)	EV150 (22-25198-02/0)
605 2.1L TD Diesel				06/89 → 09/99		157			
XUD11ATE (PHZ/P8A/P8B)	2088	4	85.00		80/109	BY941 (MLS), 1.52mm (30-027543-20) ☞0.65 → 0.76mm BY961 (MLS), 1.62mm (30-028712-10) ☞0.82 → 0.86mm BY981 (MLS), 1.72mm (30-028714-10) ☞0.92 → 0.96mm		DV150▲ (21-27540-20/0)	EV150 (22-25198-02/0)
605 2.1L TD 12V Diesel				08/94 → 09/99		158			
XUD11BTE (P8C)	2088	4	85.00		81/110	BY941 (MLS), 1.52mm (30-027543-20) ☞0.65 → 0.76mm BY961 (MLS), 1.62mm (30-028712-10) ☞0.82 → 0.86mm BY981 (MLS), 1.72mm (30-028714-10) ☞0.92 → 0.96mm		DV150▲ (21-27540-20/0)	EV150 (22-25198-02/0)
605 2.5L TD Diesel				07/94 → 09/99		159			
DK5ATE (THY)	2446	4	92.00		95/129	BY140 (Fibre) (30-029752-00)		DY140▲ (21-29752-20/0)	EY140 (22-29752-00/0)
605 3.0L				10/89 → 09/99		160			
605 3.0L SV 24				08/89 → 09/99					
ZPJ (UFZ)	2963	6	93.00	MPi, V6	123/167				
ZPJ4 (UKZ)	2963	6	93.00	MPi	147/200				
605 3.0L V6				04/97 → 09/99		161			
ES 9 J4	2946	6	87.00	Injection	140/190	AG9710 (MLS), 1.40mm ☐ AG9720 (MLS), 1.65mm ☐ AG9730 (MLS), 1.40mm ☐ AG9740 (MLS), 1.65mm ☐		CG9720☐ CG9740☐	EG9710
607 2.0L				02/00 →		162			
EW10J4 (RFN)	1997	4	85.00	MPi, DOHC	100/136	AD5300 (MLS)		CD5300	ED5300
607 2.0L HDI Diesel				05/00 → 07/04		163			
DW10ATED (RHZ)	1997	4	85.00	Common Rail	80/109	AC5011 (MLS), 1.30mm, 1 Hole ☞0.47 → 0.605mm		CC5010▲ (21-29484-20/0) → Eng.8331	EA5830
DW10ATED (RHS)	1997	4	85.00	Common Rail, DOHC	81/110	AC5031 (MLS), 1.40mm, 3 Holes (30-029479-10) ☞0.655 → 0.705mm AC5051 (MLS), 1.50mm, 5 Holes (30-029481-10) ☞0.755 → 0.83mm		CC5011▲ Eng.8332 →	

								
HBS084  (22-15005B) M12x1.50x123mm (x10)	HA512 	JN547 (50-025204-10)	JJ283 [6] (31-025198-10) ● PA349 (33-102290-10) 22x16x2mm ● PB907 14x21x2mm	HR569  24-30667-00/0	NF817 36x50x7mm, FPM (50-319112-00) NA5191  42x62x7mm, PTFE (50-319500-00) NA5192  90x110x7mm, PTFE (50-319501-00)	HL5019 [245]  NF824 [38]  NF825 [38]  KA611 [13]		BV150 BV160 BY140 BY310, BY320
HBS115  (22-15006B) M12x1.50x145mm (x10)	JD529  (31-027540-00) JD230 	JP045 (50-028922-00)	JJ283 [6] (31-025198-10) ● PA349 (33-102290-10) 22x16x2mm	HR805 	NF841 35x50x8mm, FPM (50-319310-00) NA5191  42x62x7mm, PTFE (50-319500-00) NA5192  90x110x7mm, PTFE (50-319501-00)	HL5010 [245]  NF836 [38]  NF826 [38]  KA611 [13]		HA512 JD230 JD529 JD532
HBS115  (22-15006B) M12x1.50x145mm (x10) → Eng.05571 HBS125  (22-15007B) M12x1.50x150.5mm (x10) Eng.05572 →	JD529  (31-027540-00) JD230 	JP045 (50-028922-00)	JJ283 [6] (31-025198-10) ● PA349 (33-102290-10) 22x16x2mm ● PB907 14x21x2mm	HR805 	NF841 35x50x8mm, FPM (50-319310-00) NA5191  42x62x7mm, PTFE (50-319500-00) NA5192  90x110x7mm, PTFE (50-319501-00)	HL5010 [245]  NF824 [38]  NF825 [38]  KA611 [13]		JN547 JP045
HBS125  (22-15007B) M12x1.50x150.5mm (x10)	JD529  (31-027540-00) JD230 	JP045 (50-028922-00)	● PB907 14x21x2mm	HR805 	NF841 35x50x8mm, FPM (50-319310-00) NA5191  42x62x7mm, PTFE (50-319500-00) NA5192  90x110x7mm, PTFE (50-319501-00)	HL5010 [245]  NF824 [38]  NF825 [38]  KA611 [13]		JJ283
HBS114  (22-15017B) M12x1.50x138mm (x14) M10x1.50x148mm (x8)	JD532  JD531  (31-029755-00)		JJ588 (31-029758-00) ● PA349 (33-102290-10) 22x16x2mm	HR788 	NB959  35x50x7mm, FPM (50-306644-50) NF866  64x88x6mm, FPM/ACM NF867  98x120x7mm, FPM/ACM	HL5027 [245]  NF881 [38]  NF882 [38] 		
HBS127  (22-15009B) M12x1.50x178mm (x16)		HR397 [57] 34-000410-00	● PA349 (33-102290-10) 22x16x2mm		NF869 (x2) 32x45x8mm, MVQ NA5191  42x62x7mm, PTFE (50-319500-00) NF835  80x100x8mm, FPM/ACM (50-319239-00)	NF881 [38]  NF882 [38] 		
HBS272  (22-53016B) M10x1.50x147mm (x16)	JD5879  JD5880  (Steel Elastomer) JD5878  (MLS)		● PA349 (33-102290-10) 22x16x2mm		NF869 (x2) 32x45x8mm, MVQ NA5191  42x62x7mm, PTFE (50-319500-00) NF835  80x100x8mm, FPM/ACM (50-319239-00)	NF881 [38]  NF882 [38] 		
HBS259  (22-53010B) M11x1.50x144.5mm (x10)	JD5833 	JM5283  JM5139 	● PB907 14x21x2mm		NA5256  40x55x6.5mm	NA5205 [38]  NA5204 [38] 		
HBS261  (22-53014B) M12x1.50x131mm (x10)	JD5191  JD5190 	JM5087	● KG5157 10x20x2mm ● PB907 14x21x2mm	HR5046  (x2)	NA5035 27x47x7mm, FPM (50-319474-00) NA5191  42x62x7mm, PTFE (50-319500-00) NA5192  90x110x7mm, PTFE (50-319501-00)	HL5016 [245]  NA5205 [38]  NA5204 [38] 		







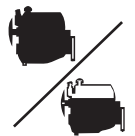



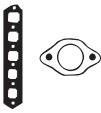

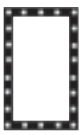

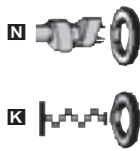



































































PEUGEOT



KW/PS



607 2.0L HDI Diesel				09/05 →		164	AD5490 (MLS), 1.25mm (30-029789-00) AD5500 (MLS), 1.30mm (30-029790-00) AD5510 (MLS), 1.35mm (30-029791-00) AD5520 (MLS), 1.40mm (30-029792-00)	CD5500▲	ED5500
DW10BTD4 (RHR)	1997	4	85.00	Direct Injection		100/136			
607 2.2L 16V				02/00 →		165	AG9750 (MLS)	CG9750	EG9750
EW12J4 (3FZ)	2230	4	86.00	MPi		118/160			
607 2.2L 16V				09/05 →		166			
EW12J4 (3FY)	2230	4	86.00	Injection, DOHC					
607 2.2L HDI Diesel				02/00 →		167	AD5490 (MLS), 1.25mm (30-029789-00) AD5500 (MLS), 1.30mm (30-029790-00) AD5510 (MLS), 1.35mm (30-029791-00) AD5520 (MLS), 1.40mm (30-029792-00)	CD5490▲ (21-29789-20/0)	ED5490 (22-29789-00/0)
DW12TED4 (4HX/4HW)	2179	4	85.00	Common Rail		100/136			
607 3.0L V6 24V				02/00 →		168	AH5060 (MLS), 0.74mm AH5070 (MLS), 0.95mm AH5040 (MLS), 0.74mm AH5050 (MLS), 0.95mm	CH5060 CH5040	
ES9J4S (XFX/XFW)	2946	6	87.00	MPi		152/207			
607 3.0L V6 24V				03/04 →		169	AH5060 (MLS), 0.74mm AH5070 (MLS), 0.95mm AH5040 (MLS), 0.74mm AH5050 (MLS), 0.95mm	CH5060 CH5040	
ES9A (XFV)	2946	6	87.00	Injection		155/211			
806 1.8L				07/95 → 08/02		170	BL650 (Fibre), 1.20mm (30-026859-10) BR510 (Fibre), 1.44mm [34] (30-026858-10)	CY131▲ (21-25204-24/0)	EL650 (22-25198-00/0)
XU7JP (LFW)	1761	4	83.00	MPi		73/99			
806 1.9L TD Diesel				07/95 → 08/02		171	BX930 (Steel Elastomer), 1.36mm, 1 Notch (30-028503-00) BX940 (Steel Elastomer), 1.40mm, 2 Notches (30-028504-00) BX950 (Steel Elastomer), 1.44mm, 3 Notches (30-028505-00) BX960 (Steel Elastomer), 1.48mm, 4 Notches (30-028506-00) BX970 (Steel Elastomer), 1.52mm, 5 Notches (30-028507-00) BX980 (Steel Elastomer), 1.59mm ☞0.83mm →	DJ720▲ (21-25202-22/0)	EL890 (22-25198-01/0) GJ720▲ (20-25202-02/0)
XUD9TE (DHX)	1905	4	83.00			66/89			
806 2.0L				06/94 → 08/02		172	BV140 (Fibre), 1.25mm (30-028760-00) BY320 (Fibre), 1.45mm [34]	CY082▲ (21-25204-23/0)	ES820 (22-25198-03/0)
XU10J2 (RFU)	1998	4	86.00	MPi		89-90/ 121- 123			

								 AD5490, AD5500, AD5510, AD5520  BL650  BV140, BY320  BX930, BX940, BX950, BX960, BX970, BX980  HA510  JC415  JC759  JD519  JN544  JN547  JJ283
HBS261  (22-53014B) M12x1.50x131mm (x10)	JD5881  Soft Material Gasket	HM5289 	KG5157 10x20x2mm PB907 14x21x2mm	HR5046  (x2)	NA5035 27x47x7mm, FPM (50-319474-00) NA5191  42x62x7mm, PTFE (50-319500-00) NA5192  90x110x7mm, PTFE (50-319501-00)	HL5016 [245]  NA5205 [38]  NA5204 [38] 		
HBS309  (22-53020B) M11x1.50x128mm (x10)	JD5883  Soft Material Gasket	JM5283  JM5139 	PB907 14x21x2mm		NA5256  40x55x6.5mm			
HBS309  (22-53020B) M11x1.50x128mm (x10)		JM5283  JM5139 	PB907 14x21x2mm					
HBS261  (22-53014B) M12x1.50x131mm (x10)		JM5141 (50-030271-00)	PB907 14x21x2mm	HR5046  (x2)	NA5035 27x47x7mm, FPM (50-319474-00) NA5191  42x62x7mm, PTFE (50-319500-00) NA5192  90x110x7mm, PTFE (50-319501-00)	HL5016 [245] 		
HBS272  (22-53016B) M10x1.50x147mm (x16)	JD5906  JD5907  (x2)  JE5069  JE5070  JE5071		PB852 16x24x1.5mm	HR5062  24-30614-73/0	NA5260 38x50x6mm			
HBS272  (22-53016B) M10x1.50x147mm (x16)	JD5906  JD5907  (x2)  JE5069  JE5070  JE5071		PB852 16x24x1.5mm	HR5062  24-30614-73/0				
HBS260  (22-53011B) M11x1.50x168mm (x10)	JD519  (x2) JC415  (x4) (31-025205-20)	JN547 (50-025204-10)	JJ283 [6] (31-025198-10) PB907 14x21x2mm	HR569  24-30667-00/0	NF817 36x50x7mm, FPM (50-319112-00) NA5191  42x62x7mm, PTFE (50-319500-00) NA5192  90x110x7mm, PTFE (50-319501-00)	HL5019 [245]  HR566 [37]  NA5205 [38]  NA5204 [38]  KA611 [13]		
HBS088  (22-15014B) M12x1.50x145mm (x10) →Eng.08574 HBS277  (22-53018B) M12x1.50x148mm (x10) Eng.08575 →	JC759 [60] (31-028417-00) (Steel)	JN544 (50-025202-00)	JJ283 [6] (31-025198-10) PA349 (33-102290-10) 22x16x2mm PB907 14x21x2mm	HR569  24-30667-00/0	NB959 35x50x7mm, FPM (50-306644-50) NF841 35x50x8mm, FPM (50-319310-00) NA5191  42x62x7mm, PTFE (50-319500-00) NA5192  90x110x7mm, PTFE (50-319501-00)	HL5010 [245]  HL5012 [245]  NA5205 [38] [61]  NA5204 [38] [61]  KA611 [13]		
HBS084  (22-15005B) M12x1.50x123mm (x10)	HA510   JC415  (x4) (31-025205-20)	JN547 (50-025204-10)	JJ283 [6] (31-025198-10) PA349 (33-102290-10) 22x16x2mm PB907 14x21x2mm	HR569  24-30667-00/0	NF817 36x50x7mm, FPM (50-319112-00) NA5191  42x62x7mm, PTFE (50-319500-00) NA5192  90x110x7mm, PTFE (50-319501-00)	HL5019 [245]  NA5205 [38]  NA5204 [38]  KA611 [13]		



KW/PS

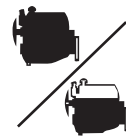

806 2.0L 16V		05/98 → 09/00			173	AY070 (Fibre) (30-029744-00)		
XU10J4R (RFV/R6E)	1998	4	86.00	MPi	99/135			
806 2.0L 16V		09/00 → 08/02			174	AD5300 (MLS)	CD5300	ED5300
EW10J4 (RFN)	1997	4	85.00	MPi, DOHC	100/136			
806 2.0L HDI Diesel		08/99 → 08/02			175	AC5011 (MLS), 1.30mm, 1 Hole ⊖0.47 → 0.605mm AC5020 (MLS), 1.35mm, 2 Holes (30-029478-00) ⊖0.605 → 0.655mm AC5031 (MLS), 1.40mm, 3 Holes (30-029479-10) ⊖0.655 → 0.705mm AC5040 (MLS), 1.45mm, 4 Holes (30-029480-00) ⊖0.705 → 0.755mm AC5051 (MLS), 1.50mm, 5 Holes (30-029481-10) ⊖0.755 → 0.83mm	CC5010▲ (21-29484-20/0) CC5011▲ Eng.8332 →	EA5830
DW10ATED (RHZ)	1997	4	85.00	Common Rail	80/109			
806 2.0L HDI 16V Diesel		08/99 → 08/02			176	AD5490 (MLS), 1.25mm (30-029789-00) AD5500 (MLS), 1.30mm (30-029790-00) AD5510 (MLS), 1.35mm (30-029791-00) AD5520 (MLS), 1.40mm (30-029792-00)		
DW10ATED4 (RHW)	1997	4	85.00	Common Rail	80/109			
806 2.0L T		06/94 → 08/02			177	BY310 (Fibre), 1.25mm (30-028761-00) BY320 (Fibre), 1.45mm [34]	DY310▲ (21-25204-25/0)	ES820 (22-25198-03/0)
XU10J2TE (RGX)	1998	4	86.00		108/147			
806 2.1L td 12V Diesel		06/96 → 08/99			178	BY941 (MLS), 1.52mm (30-027543-20) ⊖0.65 → 0.76mm BY961 (MLS), 1.62mm (30-028712-10) ⊖0.82 → 0.86mm BY981 (MLS), 1.72mm (30-028714-10) ⊖0.92 → 0.96mm	DV150▲ (21-27540-20/0)	EV150 (22-25198-02/0)
XUD11BTE (P8C)	2088	4	85.00		81/110			
807 2.0L		06/02 →			179	AD5300 (MLS)	CD5300	ED5300
EW10J4 (RFN)	1997	4	85.00	MPi, DOHC	100/136			
807 2.0L 16V		09/05 →			180	AD5300 (MLS)	CD5300	ED5300
EW10A (RFJ)	1997	4	85.00	MPi, DOHC	103/140			

HBS087 (22-15013B) M12x1.50x110mm (x10) →Eng.08581 HBS278 (22-53019B) M12x1.50x110mm (x10) Eng.08582 →	JD536 →Eng.07328		PB907 14x21x2mm	HR5080 (24-30710-45/0) →Eng.07359 HR5081 (24-30721-87/0) Eng.07360 → →Eng.07965	NF817 (x5) 36x50x7mm, FPM (50-319112-00) NA5191 42x62x7mm, PTFE (50-319500-00) NA5192 90x110x7mm, PTFE (50-319501-00)	HL5019 [245] NA5205 [38] NA5204 [38] KA611 [13]		
HBS259 (22-53010B) M11x1.50x144.5mm (x10)	JD5833	JM5283 JM5139	PB907 14x21x2mm		NA5256 40x55x6.5mm			
HBS261 (22-53014B) M12x1.50x131mm (x10)	JD5191 JD5190	JM5087	KG5157 10x20x2mm PB907 14x21x2mm	HR5046 (x2)	NA5035 27x47x7mm, FPM (50-319474-00) NA5191 42x62x7mm, PTFE (50-319500-00) NA5192 90x110x7mm, PTFE (50-319501-00)	HL5016 [245] NA5205 [38] NA5204 [38]		
HBS261 (22-53014B) M12x1.50x131mm (x10)		JM5141 (50-030271-00)	KG5157 10x20x2mm PB907 14x21x2mm	HR5046 (x2)	NA5035 27x47x7mm, FPM (50-319474-00) NA5191 42x62x7mm, PTFE (50-319500-00) NA5192 90x110x7mm, PTFE (50-319501-00)	HL5016 [245] NA5205 [38] NA5204 [38]		
HBS084 (22-15005B) M12x1.50x123mm (x10)	HA512	JN547 (50-025204-10)	JJ283 [6] (31-025198-10) PA349 (33-102290-10) 22x16x2mm PB907 14x21x2mm	HR569 24-30667-00/0	NF817 36x50x7mm, FPM (50-319112-00) NA5191 42x62x7mm, PTFE (50-319500-00) NA5192 90x110x7mm, PTFE (50-319501-00)	HL5019 [245] NF825 [38] NF824 [38] KA611 [13]		
HBS125 (22-15007B) M12x1.50x150.5mm (x10)	JD529 (31-027540-00) JD230	JP045 (50-028922-00)	PB907 14x21x2mm	HR805	NF841 35x50x8mm, FPM (50-319310-00) NA5191 42x62x7mm, PTFE (50-319500-00) NA5192 90x110x7mm, PTFE (50-319501-00)	HL5010 [245] NF824 [38] NF825 [38] KA611 [13]		
HBS259 (22-53010B) M11x1.50x144.5mm (x10)	JD5833	JM5283 JM5139	PB907 14x21x2mm		NA5256 40x55x6.5mm	HL5037 [245] NA5205 [38] NA5204 [38]		
HBS259 (22-53010B) M11x1.50x144.5mm (x10)	JD5833		PB907 14x21x2mm		NA5256 40x55x6.5mm	HL5037 [245] NA5205 [38] NA5204 [38]		



KW/PS

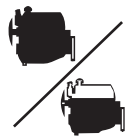

807 2.0L HDI Diesel				06/06 →		181		
DW10BTE4 (RHR)	1997	4	85.00	Direct Injection	100/136	AD5490 (MLS), 1.25mm (30-029789-00)	CD5500▲	ED5500
						AD5500 (MLS), 1.30mm (30-029790-00)		
						AD5510 (MLS), 1.35mm (30-029791-00)		
						AD5520 (MLS), 1.40mm (30-029792-00)		
807 2.0L HDI FAP Diesel				06/02 →		182		
DW10ATED4 (RHM)/ DW10ATED4 (RHT)	1997	4	85.00	Direct Injection, DOHC	79/107	AD5490 (MLS), 1.25mm (30-029789-00)	CD5490▲	ED5490
DW10ATED4 (RHW)	1997	4	85.00	Common Rail	80/109	AD5500 (MLS), 1.30mm (30-029790-00)	(21-29789-20/0)	(22-29789-00/0)
DW10UTED4 (RHK)	1997	4	85.00	Direct Injection, DOHC	85-88/ 116- 120	AD5510 (MLS), 1.35mm (30-029791-00)		
						AD5520 (MLS), 1.40mm (30-029792-00)		
807 2.2L				06/02 →		183		
EW12J4 (3FZ)	2230	4	86.00	MPi	118/160	AG9750 (MLS)	CG9750	EG9750
807 2.2L HDI FAP Diesel				06/02 →		184		
DW12TED4 (4HX/4HW)	2179	4	85.00	Common Rail	100/136	AD5490 (MLS), 1.25mm (30-029789-00)	CD5490▲	ED5490
						AD5500 (MLS), 1.30mm (30-029790-00)	(21-29789-20/0)	(22-29789-00/0)
						AD5510 (MLS), 1.35mm (30-029791-00)		
						AD5520 (MLS), 1.40mm (30-029792-00)		
807 3.0L V6				06/02 →		185		
ES9J4S (XFJ/XFW)	2946	6	87.00	MPi	152/207	AH5060 (MLS), 0.74mm <input checked="" type="checkbox"/>	CH5060 <input checked="" type="checkbox"/>	
						AH5070 (MLS), 0.95mm <input checked="" type="checkbox"/>	CH5040 <input checked="" type="checkbox"/>	
						AH5040 (MLS), 0.74mm <input checked="" type="checkbox"/>		
						AH5050 (MLS), 0.95mm <input checked="" type="checkbox"/>		
1007 1.4L				04/05 →		186		
TU3JP (KFV)	1360	4	75.00	Carburettor	55/75	AD5700 (Fibre), 1.25mm (30-026851-00)	DT012▲	EH951 [8]
						AD5710 (Fibre), 1.50mm [34] (30-029799-00)	(21-26853-20/0)	(22-25605-00/0)
1007 1.4L 16V				10/05 →		187		
KFU (ET3J4)	1360	4	75.00	Carburettor	65/88	AG9030 (Fibre), 1.4mm (30-030263-00)	CG9030	EG9030
1007 1.4L HDI Diesel				04/05 →		188		
DV4TD (8HZ)	1398	4	73.70	Direct Injection	50/68	AD5130 (MLS), 1.25mm, 2 Notches, +3 Notches (30-029277-00)	CD5130▲	ED5130
DV4TD (8HX)	1398	4	73.70	Common Rail	52/71	AD5140 (MLS), 1.30mm, 3 Notches, +3 Notches (30-029278-00)	(21-29277-00/0)	
						AD5150 (MLS), 1.35mm, 1 Notch, +3 Notches (30-029279-00)		
						AD5160 (MLS), 1.40mm, +3 Notches, 4 Notches (30-029280-00)		
						AD5170 (MLS), 1.45mm, +3 Notches, 5 Notches (30-029281-00)		
1007 1.6L 16V				04/05 →		189		
TU5JP4 (NFU/N6A)	1587	4	78.50	MPi	80/109	AD5180 (MLS), 0.62mm (30-029785-00)	CD5180	
							(21-29785-20/0)	

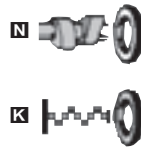
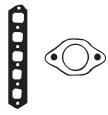

AD5130, AD5140,
AD5150, AD5160,
AD5170



AD5180



AD5490, AD5500,
AD5510, AD5520



AD5700, AD5710



JC702



JD538









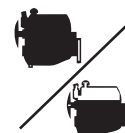

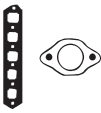

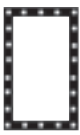

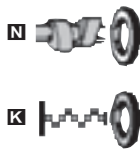



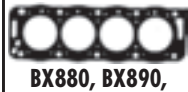



















































JN658



KW/PS



								 AD5130, AD5140, AD5150, AD5160, AD5170  AD5700, AD5710  BX880, BX890, BX900, BX910, BX920  BX930, BX940, BX950, BX960, BX970, BX980  JC423  JC759  JC991  JD538  JN544  JN658  JJ283
HBS359  (22-15018B) M11x1.50x150mm (x10)	JD5830  (50-030266-00) HA5031   (24-35043-00/0) HA5030   (24-35042-90/0) JD5829  (31-030265-00)	JM7034 (50-030264-00)				NA5258 27x47x7mm NA5259 40x55x6.4mm		
HBS039  (22-15010B) M10x1.50x175mm (x10)	JD538  (31-029472-00) JD5828   JE5072 (MLS)	JN658 (50-026853-00)	 PB852 16x24x1.5mm	HR642 		NF817 36x50x7mm, FPM (50-319112-00) NF870 42x66x6mm, FPM/ACM (50-319113-00) NF857 85x105x9mm, FPM/ACM (50-319478-00)		BX930, BX940, BX950, BX960, BX970, BX980  JC423  JC759  JC991  JD538  JN544  JN658  JJ283
HBS084  (22-15005B) M12x1.50x123mm (x10)	JC759 [60] (31-028417-00) (Steel) JC423  (x2) (31-025199-10)	JN544 (50-025202-00)	JJ283 [6] (31-025198-10)  PA349 (33-102290-10) 22x16x2mm  PB907 14x21x2mm	HR569  24-30667-00/0	NB959 35x50x7mm, FPM (50-306644-50) NA5191 42x62x7mm, PTFE (50-319500-00) NA5192 90x110x7mm, PTFE (50-319501-00)	HL5012 [245]  NF824 [38]  NF825 [38]  KA611 [13]		 JC759  JC991  JD538  JN544  JN658  JJ283
HBS088  (22-15014B) M12x1.50x145mm (x10) →Eng.08574 HBS277  (22-53018B) M12x1.50x148mm (x10) Eng.08575→	JC991 (31-028595-00) US87 & CEE19-5	JN544 (50-025202-00)	JJ283 [6] (31-025198-10)  PA349 (33-102290-10) 22x16x2mm  PB907 14x21x2mm	HR569  24-30667-00/0	NB959 35x50x7mm, FPM (50-306644-50) NA5191 42x62x7mm, PTFE (50-319500-00) NA5192 90x110x7mm, PTFE (50-319501-00)	HL5012 [245]  NF824 [38]  NF825 [38]  KA611 [13]		 JJ283
HBS088  (22-15014B) M12x1.50x145mm (x10) →Eng.08574 HBS277  (22-53018B) M12x1.50x148mm (x10) Eng.08575→	JC991 (31-028595-00)	JN544 (50-025202-00)	JJ283 [6] (31-025198-10)  PA349 (33-102290-10) 22x16x2mm  PB907 14x21x2mm	HR569  24-30667-00/0	NB959 35x50x7mm, FPM (50-306644-50) NA5191 42x62x7mm, PTFE (50-319500-00) NA5192 90x110x7mm, PTFE (50-319501-00)	HL5012 [245]  NF824 [38]  NF825 [38]  KA611 [13]		











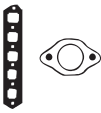

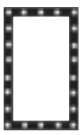

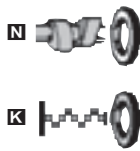







































































PEUGEOT

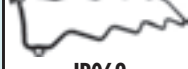

KW/PS



Boxer 2.0L						04/02 →	195	BV140 (Fibre), 1.25mm (30-028760-00)		CY081▲	ES820 (22-25198-03/0)
Boxer 2.0L i						03/94 →04/02		BY320 (Fibre), 1.45mm [34]			
Boxer 2.0L i 4x4						08/96 →04/02					
XU10J2 (RFW)	1998	4	86.00	MPi		80/109					
XU10J2 (RFL)	1998	4	86.00	MPi		81/110					
Boxer 2.0L HDI Diesel						08/01 →04/02	196	AC5011 (MLS), 1.30mm, 1 Hole ⊖0.47 →0.605mm AC5031 (MLS), 1.40mm, 3 Holes (30-029479-10) ⊖0.655 →0.705mm AC5051 (MLS), 1.50mm, 5 Holes (30-029481-10) ⊖0.755 →0.83mm		CC5010▲ (21-29484-20/0)	EA5830
DW10UTD (RHV)	1997	4	85.00	Direct Injection		62/84					
Boxer 2.2L HDI Diesel						04/02 →	197	AH5080 (MLS), 1.25mm, 1 Hole AH5090 (MLS), 1.30mm, 2 Holes AH5100 (MLS), 1.35mm, 3 Holes AH5110 (MLS), 1.40mm, 4 Holes			
DW12UTED (4HY)	2179	4	85.00	Direct Injection		74/100					
Boxer 2.5L D Diesel						03/94 →04/02	198	BY140 (Fibre) (30-029752-00)		DY140▲ (21-29752-20/0)	EY140 (22-29752-00/0)
Boxer 2.5L D 4x4 Diesel						07/96 →04/02					
Boxer 2.5L TD Diesel						03/94 →04/02					
Boxer 2.5L TD 4x4 Diesel						07/96 →04/02					
DJ5 (T9A)	2446	4	92.00			63/86					
DJ5T (T8A/THZ)	2446	4	92.00			76/103					
Boxer 2.5L TDI Diesel						01/97 →04/02	199	AE5050 (MLS) (30-029793-00)		CE5050▲ (21-29793-20/0)	
Boxer 2.5L TDI 4x4 Diesel						01/97 →04/02					
DJ5TED (THX)	2446	4	92.00			79/107					
Boxer 2.8L Diesel						01/99 →	200	AY680 (Fibre), 1.60mm (30-028607-00) AY690 (Fibre), 1.70mm (30-028608-00) AY700 (Fibre), 1.80mm (30-028609-00)		CY680▲ (21-28607-20/0)	FY690▲ (20-28607-00/0)
8140.63	2798	4	94.40	Sofim		64/87					
Boxer 2.8L HDI Diesel						11/00 →04/02	201	BX390 (Fibre), 1.20mm [71] (30-027867-00) BX400 (Fibre), 1.30mm [71] (30-027868-00) BX410 (Fibre), 1.40mm [71] (30-027883-00) BX420 (Fibre), 1.50mm [71] (30-027884-00)		DX392▲ (21-27867-22/0)	GX392▲ (20-27867-02/0)
Boxer 2.8L HDI 4x4 Diesel						04/02 →					
8140.43S	2798	4	94.40	Common Rail		107/146 92/125					
Expert 1.6L						02/96 →	202	AY460 (Fibre) [249] BR630 (Fibre) (30-027866-00)		DR630 (21-26294-21/0)	GR630 (20-26294-01/0)
220A2 (160A)	1581	4	86.40	SPi		59/80					











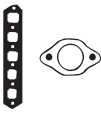

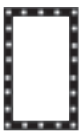

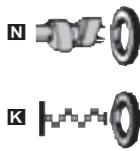











































								 AE5050	 JJ453
HBS084  (22-15005B) M12x1.50x123mm (x10)	JD519  (x2) JC415  (x4) (31-025205-20)	JN547 (50-025204-10)	JJ283 [6] (31-025198-10) ● PA349 (33-102290-10) 22x16x2mm ● PB907 14x21x2mm	HR569  24-30667-00/0	NF817 36x50x7mm, FPM (50-319112-00) NA5191  42x62x7mm, PTFE (50-319500-00) NA5192  90x110x7mm, PTFE (50-319501-00)	HL5019 [245]  NF825 [38] NF824 [38]  KA611 [13]		 AY460, BR630  AY680, AY690, AY700  BV140, BY320  BX390, BX400, BX410, BX420 	
HBS261  (22-53014B) M12x1.50x131mm (x10)	JD5191  JD5190 	JM5087	● KG5157 10x20x2mm ● PB907 14x21x2mm	HR5046  (x2)	NA5035 27x47x7mm, FPM (50-319474-00) NA5191  42x62x7mm, PTFE (50-319500-00) NA5192  90x110x7mm, PTFE (50-319501-00)	HL5016 [245]  NA5205 [38]  NA5204 [38] 		 BX390, BX400, BX410, BX420 	
HBS261  (22-53014B) M12x1.50x131mm (x10)			● PB907 14x21x2mm	HR5046 	NA5035 27x47x7mm, FPM (50-319474-00) NA5191  42x62x7mm, PTFE (50-319500-00) NA5192  90x110x7mm, PTFE (50-319501-00)	HL5016 [245] 		BY140  JC054  JC055  JC415 	
HBS114  (22-15017B) M12x1.50x138mm (x14) M10x1.50x148mm (x8)	JD532  JD531  (31-029755-00)		JJ588 (31-029758-00) ● PB852 16x24x1.5mm ● PA349 (33-102290-10) 22x16x2mm	HR788 	NB959  35x50x7mm, FPM (50-306644-50) NF866  64x88x6mm, FPM/ACM NF867  98x120x7mm, FPM/ACM	HL5027 [245]  NF881 [38] [69]  NF882 [38] [69]  KA835 [13]		 JD146  JD519 	
HBS273  (22-53017B) M12x1.50x163mm (x14) M10x1.50x174mm (x8)			● PA349 (33-102290-10) 22x16x2mm	HR642 	NB959 35x50x7mm, FPM (50-306644-50) NF866  64x88x6mm, FPM/ACM NF867  98x120x7mm, FPM/ACM	HL5027 [245]  NF881 [38] [69]  NF882 [38] [69]  KA835 [13]		 JD532  JF123 	
HBS255  (22-17021B) M12x1.25x90mm (x8) M12x1.25x160mm (x14)	JC054  (31-024274-10) JC055  (31-025031-10)  JF123 (31-027523-00)	JP069		JH5002	HR602  24-30670-61/0 NF885  [3] 70x159x16mm, FPM (50-307266-70) NF883  [3] 114x171x13mm, FPM (50-307265-70)	JR580 [11] LC280 [11] LC281 [11] LC282 [11] LS858 [11] LS859 [11] KV927 [46]		 JF150 	
HBS255  (22-17021B) M12x1.25x90mm (x8) M12x1.25x160mm (x14)	JC054  (x4) (31-024274-10) JC055  (x4) (31-025031-10)  JF123 (31-027523-00)	JP069		JH5002	HR602  24-30670-61/0 NF885  [3] 70x159x16mm, FPM (50-307266-70) NF883  [3] 114x171x13mm, FPM (50-307265-70)	KD929 [72] [73] KD931 [72] [73] Steel KD932 [72] [73] Steel JR580 [11] LC280 [11] LC281 [11] Rubber LC282 [11]		 JP069 	
HBS051  (22-17001B) M10x1.25x98mm (x5) M10x1.25x84mm (x5)	JD146 (31-027221-10)  JF150 (31-027151-00)	JP049 (31-026820-00)		JJ453	HR363 	KA293 [13] KA294 [13] KA354 [13] LA378 [53] KT465 [54] KT754 [11] KT756 [11] LR902 [11] KV122 [56]		 JH5002 	



KW/PS



Expert 1.8L		10/96 → 09/00			203	BL650 (Fibre), 1.20mm (30-026859-10) BR510 (Fibre), 1.44mm [34] (30-026858-10)	CY131▲ (21-25204-24/0)	EL650 (22-25198-00/0)
	1761	4			74/101			
Expert 1.9L D Diesel		02/96 →			204	BX880 (Fibre), 1.36mm, 1 Notch (30-028475-00) →0.56 →0.67mm BX890 (Fibre), 1.40mm, 2 Notches (30-028476-00) →0.68 →0.71mm BX900 (Fibre), 1.44mm, 3 Notches (30-028477-00) →0.72 →0.75mm BX910 (Fibre), 1.48mm, 4 Notches (30-028478-00) →0.76 →0.79mm BX920 (Fibre), 1.52mm, 5 Notches (30-028479-00) →0.80 →0.83mm	DJ720▲ (21-25202-22/0)	EL890 (22-25198-01/0) GJ720▲ (20-25202-02/0)
XUD9A (D9B)	1905	4	83.00		51/70			
Expert 1.9L D 70 Diesel		12/98 →			205	AA5830 (Steel Elastomer), 1.26mm, 1 Hole (30-029190-00) →0.51 →0.54mm AA5840 (Steel Elastomer), 1.30mm, 2 Holes (30-029191-00) →0.55 →0.58mm AA5850 (Steel Elastomer), 1.34mm, 3 Holes (30-029192-00) →0.59 →0.62mm AA5860 (Steel Elastomer), 1.38mm, 4 Holes (30-029193-00) →0.63 →0.66mm AA5870 (Steel Elastomer), 1.42mm, 5 Holes (30-029194-00) →0.67 →0.70mm AA5880 (Steel Elastomer), 1.46mm, 6 Holes (30-029195-00) →0.71 →0.75mm	CA5830▲ (21-29482-20/0)	EA5830
DW8 (WJZ)/DW8B (WJY)	1868	4	82.20	SOHC	51/69			
Expert 1.9L TD Diesel		02/96 →			206	BX930 (Steel Elastomer), 1.36mm, 1 Notch (30-028503-00) BX940 (Steel Elastomer), 1.40mm, 2 Notches (30-028504-00) BX950 (Steel Elastomer), 1.44mm, 3 Notches (30-028505-00) BX960 (Steel Elastomer), 1.48mm, 4 Notches (30-028506-00) BX970 (Steel Elastomer), 1.52mm, 5 Notches (30-028507-00) BX980 (Steel Elastomer), 1.59mm →0.83mm →	DJ720▲ (21-25202-22/0)	EL890 (22-25198-01/0) GJ720▲ (20-25202-02/0)
XUD9TE (D8B)/ XUD9TE (DHX)	1905	4	83.00		66/89			
Expert 2.0L		07/00 →			207	AD5300 (MLS)	CD5300	ED5300
EW10J4 (RFN)	1997	4	85.00	MPi, DOHC	100/136			

								
HBS260  (22-53011B) M11x1.50x168mm (x10)	JD519  (x2) JC415  (x4) (31-025205-20)	JN547 (50-025204-10)	JJ283 [6] (31-025198-10) PB907 14x21x2mm	HR569  24-30667-00/0	NF817 36x50x7mm, FPM (50-319112-00) NA5191  42x62x7mm, PTFE (50-319500-00) NA5192  90x110x7mm, PTFE (50-319501-00)	HL5019 [245]  HR566 [37]  NA5205 [38]  NA5204 [38]  KA611 [13]	 AA5830, AA5840, AA5850, AA5860, AA5870, AA5880  BL650  BX880, BX890, BX900, BX910, BX920  BX930, BX940, BX950, BX960, BX970, BX980  JC415  JC759  JD519  JN544  JN547  JJ283	
HBS084  (22-15005B) M12x1.50x123mm (x10)	JC759 [60] (31-028417-00) (Steel)	JN544 (50-025202-00)	JJ283 [6] (31-025198-10) PA349 (33-102290-10) 22x16x2mm PB907 14x21x2mm	HR569  24-30667-00/0	NB959 35x50x7mm, FPM (50-306644-50) NA5191  42x62x7mm, PTFE (50-319500-00) NA5192  90x110x7mm, PTFE (50-319501-00)	HL5012 [245]  NA5205 [38]  NA5204 [38]  KA611 [13]		
HBS084  (22-15005B) M12x1.50x123mm (x10) →Eng.08469 HBS245  (22-53008B) M12x1.50x125mm (x10) Eng.08470 →	HA5008   JD5192  (x2)	JM5088   JM5089 	KG5157 10x20x2mm PB907 14x21x2mm	HR569  24-30667-00/0	NB959 35x50x7mm, FPM (50-306644-50) NA5191  42x62x7mm, PTFE (50-319500-00) NA5192  90x110x7mm, PTFE (50-319501-00)	HL5012 [245]  NA5205 [38]  NA5204 [38] 		
HBS088  (22-15014B) M12x1.50x145mm (x10) →Eng.08574 HBS277  (22-53018B) M12x1.50x148mm (x10) Eng.08575 →	JC759 [60] (31-028417-00) (Steel)	JN544 (50-025202-00)	JJ283 [6] (31-025198-10) PA349 (33-102290-10) 22x16x2mm PB907 14x21x2mm	HR569  24-30667-00/0	NB959 35x50x7mm, FPM (50-306644-50) NA5191  42x62x7mm, PTFE (50-319500-00) NA5192  90x110x7mm, PTFE (50-319501-00)	HL5012 [245]  NF824 [38]  NF825 [38]  KA611 [13]		
HBS259  (22-53010B) M11x1.50x144.5mm (x10)	JD5833 		PB907 14x21x2mm		NA5256  40x55x6.5mm			







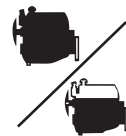



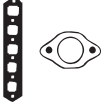

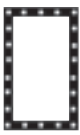

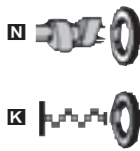

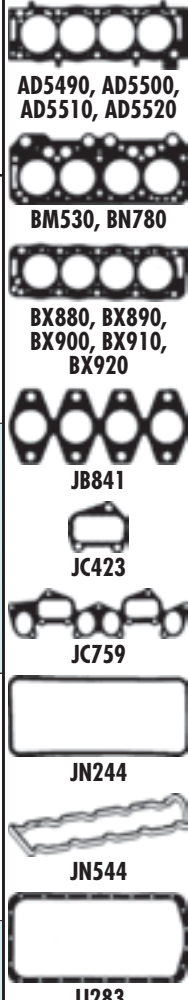









































PEUGEOT



KW/PS



Expert 2.0L HDI Diesel				07/00 →		208			
DW10ATED (RHZ)	1997	4	85.00	Common Rail	80/109	AC5011 (MLS), 1.30mm, 1 Hole [30-029479-10] [30-029479-10] [30-029479-10] [30-029479-10]	CC5010▲ (21-29484-20/0) →Eng.8331 CC5011▲ Eng.8332 →	EA5830	
Expert 2.0L HDI Diesel				07/00 →		209			
DW10BTED (RHZ)	1997	4	85.00	Direct Injection	69/93	AC5011 (MLS), 1.30mm, 1 Hole [30-029479-10] [30-029479-10] [30-029479-10] [30-029479-10]	CC5010▲ (21-29484-20/0)	EA5830	
Expert 2.0L HDI Diesel				07/00 →		210			
DW10ATED4 (RHW)	1997	4	85.00	Common Rail	80/109	AD5490 (MLS), 1.25mm [30-029789-00] AD5500 (MLS), 1.30mm [30-029790-00] AD5510 (MLS), 1.35mm [30-029791-00] AD5520 (MLS), 1.40mm [30-029792-00]			
Expert 2.0L HDI 120 Diesel				01/07 →		211	AD5490 (MLS), 1.25mm [30-029789-00] AD5500 (MLS), 1.30mm [30-029790-00] AD5510 (MLS), 1.35mm [30-029791-00] AD5520 (MLS), 1.40mm [30-029792-00]	CD5500▲	ED5500
Expert 2.0L HDI 140 Diesel				01/07 →					
DW10UTED4 (RHK)	1997	4	85.00	Direct Injection, DOHC	85-88/ 116- 120				
DW10BTED4 (RHR)	1997	4	85.00	Direct Injection	100/136				
J5 1.8L				01/83 → 11/88		212			
XM7T (169B)	1976	4	84.00	Carburettor	51/69		DM533▲	EM531	
J5 1.9L D Diesel				10/90 →		213			
XUD9A (D9B/DJY/DJZ)	1905	4	83.00		51/69	BX880 (Fibre), 1.36mm, 1 Notch [30-028475-00] [30-028475-00] [30-028475-00] [30-028475-00]	DJ720▲ (21-25202-22/0)	EL890 (22-25198-01/0) GJ720▲ (20-25202-02/0)	
J5 2.0L				09/81 → 09/90		214			
XN1T (170)/XN1T (170B)	1971	4	88.00	Carburettor	57/77	BM530 (Fibre), 1.40mm [30-025376-10]	DM530■ DM533▲	EM531	
XN1T (170D)	1971	4	88.00	Carburettor	62/84	BN780 (Fibre), 1.60mm [34]			

								
HBS261  (22-53014B) M12x1.50x131mm (x10)	JD5191  JD5190 	JM5087	KG5157 10x20x2mm PB907 14x21x2mm	HR5046  (x2)	NA5035 27x47x7mm, FPM (50-319474-00) NA5191  42x62x7mm, PTFE (50-319500-00) NA5192  90x110x7mm, PTFE (50-319501-00)	HL5016 [245]  NA5205 [38]  NA5204 [38] 		AD5490, AD5500, AD5510, AD5520 BM530, BN780 BX880, BX890, BX900, BX910, BX920 JB841 JC423 JC759 JN244 JN544 JJ283
HBS261  (22-53014B) M12x1.50x131mm (x10)	JD5191  JD5190 	JM5087	KG5157 10x20x2mm PB907 14x21x2mm	HR5046  (x2)	NA5035 27x47x7mm, FPM (50-319474-00) NA5191  42x62x7mm, PTFE (50-319500-00) NA5192  90x110x7mm, PTFE (50-319501-00)	HL5016 [245]  NA5205 [38]  NA5204 [38] 		
HBS261  (22-53014B) M12x1.50x131mm (x10)		JM5141 (50-030271-00)	KG5157 10x20x2mm PB907 14x21x2mm	HR5046  (x2)	NA5035 27x47x7mm, FPM (50-319474-00) NA5191  42x62x7mm, PTFE (50-319500-00) NA5192  90x110x7mm, PTFE (50-319501-00)	HL5016 [245]  NA5205 [38]  NA5204 [38] 		
HBS261  (22-53014B) M12x1.50x131mm (x10)	JD5881 	HM5289 	KG5157 10x20x2mm PB907 14x21x2mm	HR5046  (x2)	NA5035 27x47x7mm, FPM (50-319474-00) NA5191  42x62x7mm, PTFE (50-319500-00) NA5192  90x110x7mm, PTFE (50-319501-00)	HL5016 [245]  NA5205 [38]  NA5204 [38] 		
HBS038  (22-15003B) M11x1.50x175mm (x10) HBS086  M11x1.50x179mm (x10)	JB841  (31-018363-10)	JN244	PA349 (33-102290-10) 22x16x2mm	HR569  24-30667-00/0	NA5191  42x62x7mm, PTFE (50-319500-00)	HL472 [37]  NF369 (x2) [38]		
HBS084  (22-15005B) M12x1.50x123mm (x10)	JC759 [60] (31-028417-00) (Steel) JC423  (x2) (31-025199-10)	JN544 (50-025202-00)	JJ283 [6] (31-025198-10) PA349 (33-102290-10) 22x16x2mm PB907 14x21x2mm	HR569  24-30667-00/0	NF841 35x50x8mm, FPM (50-319310-00) NA5191  42x62x7mm, PTFE (50-319500-00) NA5192  90x110x7mm, PTFE (50-319501-00)	HL5010 [245]  NF369 (x2) [38] KA611 [13]		
HBS038  (22-15003B) M11x1.50x175mm (x10) HBS086  M11x1.50x179mm (x10)	JB841  (31-018363-10)	JN244	PA349 (33-102290-10) 22x16x2mm	HR569  24-30667-00/0	NA5191  42x62x7mm, PTFE (50-319500-00)	HL472 [37]  NF369 (x2) [38]		







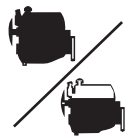



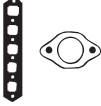

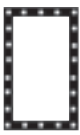

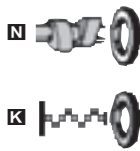









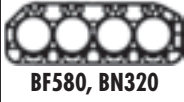
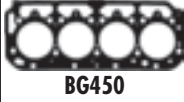
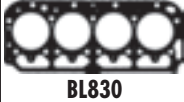

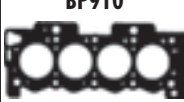









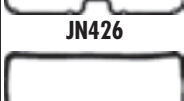







































PEUGEOT



KW/PS



J5 2.5L D Diesel		09/81 → 09/90			215	BG450 (Fibre), 1.35mm (30-025842-10)	DG452▲■ (21-25842-21/0)	GG452○ (20-25842-02/0) 12/83 →
CRD93 (U25/651/661)	2500	4	93.00		54/73			
J5 2.5L D Diesel		10/90 →			216	BG450 (Fibre), 1.35mm (30-025842-10)	DG452▲■ (21-25842-21/0)	GG452○ (20-25842-02/0)
J5 2.5L D 4x4 Diesel		10/90 →						
CRD93 (U25/651/661)	2500	4	93.00		54/73			
J5 2.5L TD Diesel		10/90 →			217	BL830 (Fibre), 1.80mm (30-026869-10)	DL831▲■	GL830
J5 2.5L TD 4x4 Diesel		10/90 →						
CRD93LS (U25/673)	2500	4	93.00		70/95			
J9 1.6L		03/80 → 06/87			218		DM710○	GM710■○ [36]
XC7P	1618	4	84.00	Carburettor	46/63			
J9 2.0L		03/80 → 06/87			219	BM530 (Fibre), 1.40mm (30-025376-10) BN780 (Fibre), 1.60mm [34]	DM530■ DM533▲	GM533■○
XN1P	1971	4	88.00	Carburettor	57/77			
J9 2.1L D Diesel		03/80 → 06/87			220	BF580 (Fibre), 1.40mm [22] BN320 (Fibre), 1.58mm, 1 Notch [22]	DF580 [23] (21-23775-21/0) DG050▲■ (21-24586-24/0)	EF580 GF583 [23] GN320 [64]
XDPX90	2112	4	90.00		41/55			
J9 2.3L D Diesel		03/80 → 07/82			221	BP890 (Fibre), 1.53mm, 2 Notches (30-026144-10) BP900 (Fibre), 1.63mm, 3 Notches (30-026145-10) BP910 (Fibre), 1.73mm, 4 Notches (30-026146-10) 05/80 →	DG050▲■ (21-24586-24/0)	EH890 GG050▲○
XD2P / XD94	2304	4	94.00		49/67			
J9 2.5L D Diesel		07/82 → 06/87			222	BP890 (Fibre), 1.53mm, 2 Notches (30-026144-10) BP900 (Fibre), 1.63mm, 3 Notches (30-026145-10) BP910 (Fibre), 1.73mm, 4 Notches (30-026146-10)	DH890▲■	EH890 GH890▲○ (20-24586-05/0)
XD3P	2498	4	94.00		53/72			
Partner 1.1L		06/96 →			223	BR490 (Fibre), 1.50mm [34] (30-029800-00)	DT012▲ (21-26853-20/0)	EH951 [8] (22-25605-00/0) EH952 (22-25605-02/0)
TU1M (HDZ)	1124	4	72.00	SPi	44/60			







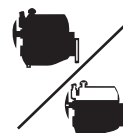



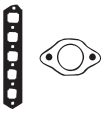

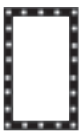

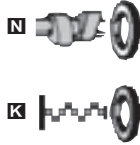











































































































								
HBS017  [22-15008B] M12x1.50x145mm (x8) M12x1.50x118mm (x9)	JB868  (x4) JB869  (x4)	JN426	PA217 16.3x22x2mm PA349 [33-102290-10] 22x16x2mm	HR340 	NF741 29x46x10mm, ACM NF637  48x65x10mm, FPM (50-306222-50) →12/83 NF776  75x90x11.5mm, FPM/ACM 01/84→ NF752  95x112x12.5mm, FPM 01/84→	HL5022 [245]  NF778 [70] 12/83→ NF369 (x2) [38]	 BF580, BN320  BG450  BL830  BM530, BN780  BP890, BP900, BP910  BR490  JB841  JB842  JB868  JB869  JC566  JC702  JD551  JE189  JN244  JN245  JN426  JN658	
HBS017  [22-15008B] M12x1.50x145mm (x8) M12x1.50x118mm (x9)	JB868  (x4) JB869  (x4)	JN426	PA217 16.3x22x2mm PA349 [33-102290-10] 22x16x2mm	HR340 	NF741 29x46x10mm, ACM NF776  75x90x11.5mm, FPM/ACM NF752  95x112x12.5mm, FPM	HL5022 [245]  NF778 [70] NF369 (x2) [38]		
HBS017  [22-15008B] M12x1.50x145mm (x8) M12x1.50x118mm (x9)	JB868  (x4) JB869  (x4)	JN426	PA217 16.3x22x2mm PA349 [33-102290-10] 22x16x2mm	HR340 	NF741 29x46x10mm, ACM NF776  75x90x11.5mm, FPM/ACM NF752  95x112x12.5mm, FPM	HL5022 [245]  NF778 [70] NF369 (x2) [38]		
HBS038  [22-15003B] M11x1.50x175mm (x10) HBS086  M11x1.50x179mm (x10)	JB841  [31-018363-10]	JN244	KJ647 18.3x24x2mm PA349 [33-102290-10] 22x16x2mm	HR569  24-30667-00/0		HL472 [37]  HR574 [37]  NF096 (x2) [38]		
HBS038  [22-15003B] M11x1.50x175mm (x10) HBS086  M11x1.50x179mm (x10)	JB841  [31-018363-10]	JN244	PA349 [33-102290-10] 22x16x2mm	HR569  24-30667-00/0		HL472 [37]  HR574 [37]  NF096 (x2) [38]		
	JB842  (x2)	JN245 (50-024586-00)	HC346  PA349 [33-102290-10] 22x16x2mm	PA229 (x8) (50-324505-00)	NF387  42x60x10mm, NBR (50-306429-00)	NF096 (x2) [38] KA606 [13]		
	JB842  (x2)	JN245 (50-024586-00)	HC346  PA349 [33-102290-10] 22x16x2mm	PA229 (x8) (50-324505-00)	NF387  42x60x10mm, NBR (50-306429-00)	NF096 (x2) [38] KA606 [13]		
HBS015  [22-53004B] M11x1.50x97.5mm (x8) M11x1.50x120mm (x7) M11x1.50x107.5mm (x7) →08/87 HBS016  [22-53005B] M11x1.50x120mm (x7) M11x1.50x107.5mm (x15) 09/87→	JC566  (x2)	JN245 (50-024586-00)	HC346  PA349 [33-102290-10] 22x16x2mm		NF387  42x60x10mm, NBR (50-306429-00)	NF096 (x2) [38] KA606 [13]		
HBS039  [22-15010B] M10x1.50x175mm (x10)	JD551  (x2) [31-029803-00] JC702  (x2) [31-029804-00]  JE189 [31-029805-00]	JN658 (50-026853-00)	JJ586 [31-029806-00] PB852 16x24x1.5mm PA349 [33-102290-10] 22x16x2mm	HR642 	NF817 36x50x7mm, FPM (50-319112-00) NF870  42x66x6mm, FPM/ACM (50-319113-00) NF857  85x105x9mm, FPM/ACM (50-319478-00)	HL5011 [245]  HR564 [37]  NA5205 [38]  NA5204 [38]  PA850 [13]		



KW/PS



Partner 1.1L				06/96 →	224			AD5700 (Fibre), 1.25mm (30-026851-00)	CC5700 (21-29572-20/0)	EH951 [8] (22-25605-00/0)
TU1JP (HFX)	1124	4	72.00	MPI	44/60			TU1M	TU1JP	TU1M
TU1M (HDZ)	1124	4	72.00	SPi	44/60			AC5700 (Fibre), 1.26mm (30-029572-00)	DT010 (21-26851-20/0)	EH952 (22-25605-02/0)
								TU1JP	TU1M	TU1M
								BS810 (Fibre), 1.30mm (30-026850-00)	DT012▲ (21-26853-20/0)	
								TU1M+	TU1M	
								AD5710 (Fibre), 1.50mm [34] (30-029799-00)		
								TU1M		
								BR490 (Fibre), 1.50mm [34] (30-029800-00)		
								TU1M+		
Partner 1.4L				06/96 →	225			AD5700 (Fibre), 1.25mm (30-026851-00)	DT012▲ (21-26853-20/0)	EH951 [8] (22-25605-00/0)
TU32	1360	4	75.00		51-52/ 70-71			AD5710 (Fibre), 1.50mm [34] (30-029799-00)		
TU3JP (KFW/ K6D)/TU3JP (KFX)	1360	4	75.00	MPI, SOHC	55/75					
Partner 1.4L BiFuel				04/03 →	226			AD5700 (Fibre), 1.25mm (30-026851-00)	DT012▲ (21-26853-20/0)	EH951 [8] (22-25605-00/0)
TU3JP (KFW/K6D)	1360	4	75.00	MPI, SOHC	55/75			AD5710 (Fibre), 1.50mm [34] (30-029799-00)		
Partner 1.6L 16V				07/01 →	227			AD5180 (MLS), 0.62mm (30-029785-00)	CD5180 (21-29785-20/0)	ED5180
TU5JP4 (NFU/N6A)	1587	4	78.50	MPI	80/109					
Partner 1.8L D Diesel				06/96 →	228			BX830 (Fibre), 1.36mm, 1 Notch (30-028484-00)	DJ720▲ (21-25202-22/0)	EL890 (22-25198-01/0)
XUD7 (A9A)	1769	4	80.00		44/60			0.56 → 0.67mm		GJ720▲ (20-25202-02/0)
								BX840 (Fibre), 1.40mm, 2 Notches (30-028485-00)		
								0.68 → 0.71mm		
								BX850 (Fibre), 1.44mm, 3 Notches (30-028486-00)		
								0.72 → 0.75mm		
								BX860 (Fibre), 1.48mm, 4 Notches (30-028487-00)		
								0.76 → 0.79mm		
								BX870 (Fibre), 1.52mm, 5 Notches (30-028488-00)		
								0.80 → 0.83mm		

								
HBS039  [22-15010B] M10x1.50x175mm (x10)	JD551  (x2) (31-029803-00) TU1M JD5828  HA5028   JC702  (x2) (31-029804-00) TU1M  JE189 (31-029805-00) TU1M	JN658 (50-026853-00)	JJ586 (31-029806-00) TU1M  PB852 16x24x1.5mm  PA349 (33-102290-10) 22x16x2mm	HR642 	 NF817 36x50x7mm, FPM (50-319112-00)  NF870  42x66x6mm, FPM/ACM (50-319113-00)  NF857  85x105x9mm, FPM/ACM (50-319478-00)	HL5011 [245]  HR564 [37]  NA5205 [38]  NA5204 [38]  PA850 [13]	 AC5700  AD5180  AD5700, AD5710  BS810, BR490  BX830, BX840, BX850, BX860, BX870  JC702  JC759  JD538  JD551  JE189  JN544  JN658  JJ283  JJ586	
HBS039  [22-15010B] M10x1.50x175mm (x10)	JD538  (x4) (31-029472-00) JD5828  HA5028   JC702  (x2) (31-029804-00)  JE5072 (MLS)	JN658 (50-026853-00)	 PB852 16x24x1.5mm  PA349 (33-102290-10) 22x16x2mm	HR642 	 NF817 36x50x7mm, FPM (50-319112-00)  NF870  42x66x6mm, FPM/ACM (50-319113-00)  NF857  85x105x9mm, FPM/ACM (50-319478-00)	HL5011 [245]  HR564 [37]  NA5205 [38]  NA5204 [38]  PA850 [13]	 JC702  JC759  JD538  JD551  JE189  JN544  JN658  JJ283  JJ586	
HBS039  [22-15010B] M10x1.50x175mm (x10)	JD538  (x4) (31-029472-00) JC702  (x2) (31-029804-00)  JE5072 (MLS)	JN658 (50-026853-00)	 PB852 16x24x1.5mm	HR642 	 NF817 36x50x7mm, FPM (50-319112-00)  NF870  42x66x6mm, FPM/ACM (50-319113-00)  NF857  85x105x9mm, FPM/ACM (50-319478-00)	HL5011 [245]  HR564 [37]  NA5205 [38]  NA5204 [38]  PA850 [13]	 JD551  JE189  JN544  JN658  JJ283  JJ586	
HBS254  [22-53009B] M10x1.50x122mm (x10)	HA5032   [24-35043-10/0] JD5831   JE5072 (MLS)	JM7035 (50-030267-00)	 PB852 16x24x1.5mm  PA349 (33-102290-10) 22x16x2mm		 NA5260 38x50x6mm  NF870  42x66x6mm, FPM/ACM (50-319113-00)  NF857  85x105x9mm, FPM/ACM (50-319478-00)	HL5038 [245]  NA5205 [38]  NA5204 [38] 	 JN544  JN658  JJ283  JJ586	
HBS084  [22-15005B] M12x1.50x123mm (x10)	JC759 [60] (31-028417-00) (Steel)	JN544 (50-025202-00)	JJ283 [6] (31-025198-10)  PA349 (33-102290-10) 22x16x2mm  PB907 14x21x2mm	HR569  24-30667-00/0	 NB959 35x50x7mm, FPM (50-306644-50)  NA5191  42x62x7mm, PTFE (50-319500-00)  NA5192  90x110x7mm, PTFE (50-319501-00)	HL5012 [245]  NA5205 [38]  NA5204 [38]  KA611 [13]	 JN544  JN658  JJ283  JJ586	



KW/PS

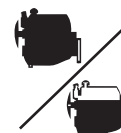

Partner 1.9L D Diesel					06/96 →	229		
Partner 1.9L D 4x4 Diesel					04/04 →		CA5830▲	EA5830
DW8 (WJZ)/DW8B (WJY)	1868	4	82.20	SOHC	51/69	AA5830 (Steel Elastomer), 1.26mm, 1 Hole (30-029190-00) ☞0.51 → 0.54mm AA5840 (Steel Elastomer), 1.30mm, 2 Holes (30-029191-00) ☞0.55 → 0.58mm AA5850 (Steel Elastomer), 1.34mm, 3 Holes (30-029192-00) ☞0.59 → 0.62mm AA5860 (Steel Elastomer), 1.38mm, 4 Holes (30-029193-00) ☞0.63 → 0.66mm AA5870 (Steel Elastomer), 1.42mm, 5 Holes (30-029194-00) ☞0.67 → 0.70mm AA5880 (Steel Elastomer), 1.46mm, 6 Holes (30-029195-00) ☞0.71 → 0.75mm	(21-29482-20/0)	
Partner 1.9L D Diesel					06/96 →	230		
XUD9A (DJY/D9B)	1905	4	83.00		51/69	BX880 (Fibre), 1.36mm, 1 Notch (30-028475-00) ☞0.56 → 0.67mm BX890 (Fibre), 1.40mm, 2 Notches (30-028476-00) ☞0.68 → 0.71mm BX900 (Fibre), 1.44mm, 3 Notches (30-028477-00) ☞0.72 → 0.75mm BX910 (Fibre), 1.48mm, 4 Notches (30-028478-00) ☞0.76 → 0.79mm BX920 (Fibre), 1.52mm, 5 Notches (30-028479-00) ☞0.80 → 0.83mm	DJ720▲ (21-25202-22/0)	EL890 (22-25198-01/0) GJ720▲ (20-25202-02/0)
Partner 2.0L HDI Diesel					02/00 →	231		
Partner 2.0L HDI 4x4 Diesel					04/04 →		CC5010▲	EA5830
DW10TD (RHY)	1997	4	85.00	Common Rail	63/86	AC5011 (MLS), 1.30mm, 1 Hole ☞0.47 → 0.605mm AC5031 (MLS), 1.40mm, 3 Holes (30-029479-10) ☞0.655 → 0.705mm AC5051 (MLS), 1.50mm, 5 Holes (30-029481-10) ☞0.755 → 0.83mm	(21-29484-20/0)	

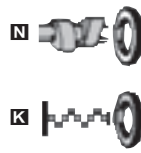
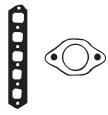

AA5830, AA5840,
AA5850, AA5860,
AA5870, AA5880



BX880, BX890,
BX900, BX910,
BX920



JC759



JN544



JJ283

HBS084

(22-15005B)
M12x1.50x123mm (x10)
→Eng.08469
HBS245

(22-53008B)
M12x1.50x125mm (x10)
Eng.08470 →

HA5008

JD5192 (x2)

JM5088

JM5089

KG5157

10x20x2mm
PB907

14x21x2mm

HR569

24-30667-00/0

NB959 35x50x7mm, FPM
(50-306644-50)
NA5191 42x62x7mm, PTFE
(50-319500-00)
NA5192 90x110x7mm, PTFE
(50-319501-00)

HL5012 [245]

NA5205 [38]

NA5204 [38]

HBS084

(22-15005B)
M12x1.50x123mm (x10)

JC759 [60]
(31-028417-00)
(Steel)

JN544
(50-025202-00)

JJ283 [6]
(31-025198-10)
PA349
(33-102290-10)
22x16x2mm
PB907

14x21x2mm

HR569

24-30667-00/0

NB959 35x50x7mm, FPM
(50-306644-50)
NA5191 42x62x7mm, PTFE
(50-319500-00)
NA5192 90x110x7mm, PTFE
(50-319501-00)

HL5012 [245]

NA5205 [38]

NA5204 [38]

KA611 [13]

HBS261

(22-53014B)
M12x1.50x131mm (x10)

JD5191

JD5190

JM5087

KG5157

10x20x2mm
PB907

14x21x2mm

HR5046 (x2)

NA5035 27x47x7mm, FPM
(50-319474-00)
NA5191 42x62x7mm, PTFE
(50-319500-00)
NA5192 90x110x7mm, PTFE
(50-319501-00)

HL5016 [245]

NA5205 [38]

NA5204 [38]







PROTON

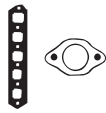

KW/PS

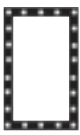

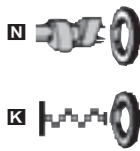
Persona 300 313i 03/96 → 1						BT430 (Graphite) (30-028224-00)	DT430 (21-28224-20/0)	
Mitsubishi G13B	1299	4	71.00	Injection, SOHC	55/75			
Persona 300 315 GLi/GLSi 03/96 → 2						BT430 (Graphite) (30-028224-00)	DT430 (21-28224-20/0)	
Persona 300 315 GLSi 09/96 →								
Mitsubishi G15B	1468	4	75.50	Injection, SOHC	64-66/ 87-90			
Persona 300 316 03/96 → 3						BT890 (Graphite) (30-028919-00)	DT890	
Persona 300 316 GLXi 03/96 →								
4 G92	1597	4	81.00	Injection, SOHC	70-83/ 95-113			
Persona 400 413 01/94 → 4						BT430 (Graphite) (30-028224-00)	DT430 (21-28224-20/0)	
Persona 400 413 GLSi 01/94 →								
4 G13	1299	4	71.00	Injection, SOHC	50-56/ 68-76			
Persona 400 415 GLi/GLSi 01/94 → 5						BT430 (Graphite) (30-028224-00)	DT430 (21-28224-20/0)	
4 G15	1468	4	75.50	Injection, SOHC	64-66/ 86-90			
Persona 400 415 GLi/GLSi 01/94 → 6						BT430 (Graphite) (30-028224-00)	DT430 (21-28224-20/0)	
4 G15	1468	4	75.50	Injection, SOHC	64-66/ 86-90			
Persona 400 416 GLXi 01/94 → 7						BT890 (Graphite) (30-028919-00)	DT890	GT890
Persona 400 416 i 12/95 →								
4 G92	1597	4	81.00	Injection, SOHC	70-83/ 95-113			
Persona 400 418 05/96 → 8						BT890 (Graphite) (30-028919-00)	DT890	GT890
Persona 400 418 GLXi 05/96 →								
4 G93	1834	4			85/115			
Persona 400 420 D Diesel 09/96 → 9						AG5300 (Graphite), 1.45mm, 2 Holes	CG5520 ▲	EG6280
Persona 400 420 GLS D Diesel 05/96 →						AG5301 (Graphite), 1.5mm, 3 Notches		
Persona 400 420 TD Diesel 09/96 →						4D68		
4 D 68	1998	4	82.70		48/65			
4 D 68 T	1998	4	82.70		60/82			
Saga 1.3L 01/85 → 10						BN330 (Graphite) (30-028175-00)	DN330 (21-28175-20/0)	GN330 GN331
G13B	1299	4	71.00	SOHC				
Saga 1.5L 01/85 → 11						BN230 (Graphite) (30-026719-10)	DN230 →12/85 DN233 (21-26719-23/0) 01/87→12/88	GN230 →12/86 GN233 01/87→12/88
G15B	1468	4	75.50	SOHC				
Saga 1.5L 01/94 → 12						BT430 (Graphite) (30-028224-00)	DT430 (21-28224-20/0)	
4 G15	1468	4	75.50		64-66/ 86-90			
Satria 1.5L 07/00 → 13						BT430 (Graphite) (30-028224-00)	DT430 (21-28224-20/0)	
4 G15	1468	4	75.50	Injection, SOHC	64-66/ 86-90			

								
HBS477 (22-75009B)	JD5757 ■	JN897						BN230
	JD5757 ■	JN897						BN330
HBS215 ⊕ (22-76001B) M10x1.25x95mm (x10)	JD5781 ■			PA425 (x16) (50-306560-50)	NJ242 35x50x8mm, NBR NK143 85x103x8mm, FPM			BT430
	JD5757 ■	JN897						BT890
HBS477 (22-75009B)	JD5757 ■ JD023 ■	JN897		PA968 (x12)	NJ242 35x50x8mm, NBR NJ252 30x46x7mm, NBR NJ006 72x96x9mm, FPM/ACM			HA414
	JD5757 ■ JD023 ■	JN897		PA968 (x12)	NJ242 35x50x8mm, NBR NJ252 30x46x7mm, NBR NJ006 72x96x9mm, FPM/ACM			JC023
HBS215 ⊕ (22-76001B) M10x1.25x95mm (x10)	JD5781 ■ JD007 ■	JN800		PA425 (x16) (50-306560-50)	NJ242 35x50x8mm, NBR NK143 85x103x8mm, FPM			JC122
HBS215 ⊕ (22-76001B) M10x1.25x95mm (x10)	JD5781 ■ JD007 ■	JN800		PA425 (x16) (50-306560-50)	NJ242 35x50x8mm, NBR NK143 85x103x8mm, FPM			JC123
HBS421 (22-76024B) M11x1.25x118mm (x10)					NJ242 35x50x8mm, NBR NJ005 44x60x7mm, NBR NK143 85x103x8mm, FPM			JC719
	JC122 ■ JC123 ■ HA414 ■ ■ JC023 ■ ⊕ JE199	JN317 (50-026219-00)	JJ098	KJ570 (x8) KJ577 (x4) [202]	NJ242 35x50x8mm, NBR NJ252 30x46x7mm, NBR NJ006 72x96x9mm, FPM/ACM			JC793
	JC122 ■ →12/87 JC123 ■ →12/88 JC793 ■ 01/87→12/88 HA414 ■ ■ →12/88 JC023 ■ JC719 ■	JN317 (50-026219-00) →12/88	JJ098 →12/88	KJ570 (x8) →12/88 KJ577 (x4) [202] →12/88	NJ242 35x50x8mm, NBR NJ252 30x46x7mm, NBR NJ006 72x96x9mm, FPM/ACM			JD007
	JD5757 ■ JD023 ■	JN897		PA968 (x12)	NJ242 35x50x8mm, NBR NJ252 30x46x7mm, NBR NJ006 72x96x9mm, FPM/ACM			JD023
	JD5757 ■ JD023 ■	JN897		PA968 (x12)	NJ242 35x50x8mm, NBR NJ252 30x46x7mm, NBR NJ006 72x96x9mm, FPM/ACM			JN317
								JN897
								JJ098







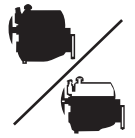

PROTON

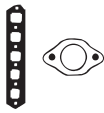

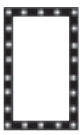

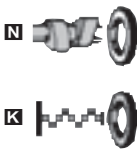
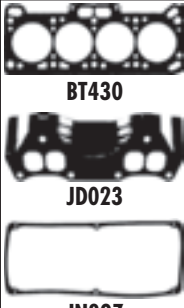













KW/PS



















Wira 1.3L				08/00 →	14	BT430 (Graphite)	DT430
4 G13	1299	4	71.00	Injection, SOHC	50-56/ 68-76	(30-028224-00)	(21-28224-20/0)
Wira 1.5L				08/00 →	15	BT430 (Graphite)	DT430
4 G15	1468	4	75.50	Injection, SOHC	64-66/ 86-90	(30-028224-00)	(21-28224-20/0)
4 G 15 M	1468	4	75.50		64-67/ 87-91		









						
	JD5757  JD023 	JN897				
	JD5757  JD023 	JN897		PA968 (x12)	<input checked="" type="checkbox"/> NJ242 35x50x8mm, NBR <input checked="" type="checkbox"/> NJ252 30x46x7mm, NBR <input checked="" type="checkbox"/> NJ006 72x96x9mm, FPM/ACM	JN897

		CC			9			CC			9
688 11	Petrol	1108	4	70.00	175	A7L 752	Petrol	1647	4	79.00	204
688 12	Petrol	1108	4	70.00	175	C1C 700	Petrol	956	4	65.00	177
688 12	Petrol	1108	4	70.00	242	C1C 708	Petrol	956	4	65.00	172
688 13	Petrol	1108	4	70.00	178	C1C 708	Petrol	956	4	65.00	174
688.10	Petrol	1108	4	70.00	188	C1E 700	Petrol	1108	4	70.00	6
689 710	Petrol	956	4	65.00	173	C1E 714	Petrol	1108	4	70.00	175
689 710	Petrol	956	4	65.00	176	C1E 715	Petrol	1108	4	70.00	189
800	Petrol	847	4	58.00	171	C1E 715	Petrol	1108	4	70.00	195
800 705	Petrol	847	4	58.00	171	C1E 715	Petrol	1108	4	70.00	6
807 727	Petrol	1565	4	77.00	204	C1E 718	Petrol	1108	4	70.00	175
810.02	Petrol	1289	4	73.00	201	C1E 719	Petrol	1108	4	70.00	175
8140.23.2565	Diesel	2800	4	94.40	133	C1E 720	Petrol	1108	4	70.00	189
8140.23.2585	Diesel	2800	4	94.40	133	C1E 720	Petrol	1108	4	70.00	195
8140.23.2585	Diesel	2800	4	94.40	4	C1E 720	Petrol	1108	4	70.00	6
8140.23.2585	Diesel	2800	4	94.40	5	C1E 726	Petrol	1108	4	70.00	178
8140.23.2585 (S(WA7))	Diesel	2800	4	94.40	133	C1E 750	Petrol	1108	4	70.00	179
8140.23.2585 (S(WA7))	Diesel	2800	4	94.40	4	C1E 750	Petrol	1108	4	70.00	236
8140.23.2585 (S(WA7))	Diesel	2800	4	94.40	5	C1E 752	Petrol	1108	4	70.00	179
8140.23.3700	Diesel	2800	4	94.40	133	C1E 752	Petrol	1108	4	70.00	236
8140.23.3700	Diesel	2800	4	94.40	4	C1E 754	Petrol	1108	4	70.00	179
8140.23.3700	Diesel	2800	4	94.40	5	C1E 754	Petrol	1108	4	70.00	236
8140.27.2500	Diesel	2499	4	93.00	131	C1E 756	Petrol	1108	4	70.00	179
8140.27.2510	Diesel	2499	4	93.00	131	C1E 756	Petrol	1108	4	70.00	236
8140.27.2580	Diesel	2499	4	93.00	131	C1E 760	Petrol	1108	4	70.00	179
8140.43.2585	Diesel	2800	4	94.40	133	C1E 760	Petrol	1108	4	70.00	236
8140.43.2585	Diesel	2800	4	94.40	4	C1E 762	Petrol	1108	4	70.00	236
8140.43.2585	Diesel	2800	4	94.40	5	C1E 792	Petrol	1108	4	70.00	236
8140.43.3700	Diesel	2800	4	94.40	133	C1G 700	Petrol	1237	4	71.50	190
8140.43.3700	Diesel	2800	4	94.40	4	C1G 700	Petrol	1237	4	71.50	196
8140.43.3700	Diesel	2800	4	94.40	5	C1G 702	Petrol	1237	4	71.50	180
8140.43.3900	Diesel	2800	4	94.40	133	C1G 710	Petrol	1237	4	71.50	190
8140.43.3900	Diesel	2800	4	94.40	4	C1G 710	Petrol	1237	4	71.50	196
8140.43.3900	Diesel	2800	4	94.40	5	C1G 720	Petrol	1237	4	71.50	180
8140.61.2300	Diesel	2445	4	93.00	127	C1G 722	Petrol	1237	4	71.50	180
8140.61.2300	Diesel	2445	4	93.00	130	C1G 730	Petrol	1237	4	71.50	209
8140.61.240	Diesel	2445	4	93.00	288	C1J 700	Petrol	1397	4	76.00	276
8140.67.2510	Diesel	2499	4	93.00	129	C1J 700	Petrol	1397	4	76.00	277
829 720	Petrol	1995	4	88.00	284	C1J 715	Petrol	1397	4	76.00	191
829 721	Petrol	1995	4	88.00	284	C1J 715	Petrol	1397	4	76.00	197
829 730	Petrol	1995	4	88.00	123	C1J 760	Petrol	1397	4	76.00	192
829 731	Petrol	1995	4	88.00	123	C1J 760	Petrol	1397	4	76.00	198
840 726	Petrol	1397	4	76.00	182	C1J 764	Petrol	1397	4	76.00	192
840 730	Petrol	1397	4	76.00	182	C1J 764	Petrol	1397	4	76.00	198
840 730	Petrol	1397	4	76.00	184	C1J 768	Petrol	1397	4	76.00	183
841 705	Petrol	1647	4	79.00	278	C1J 768	Petrol	1397	4	76.00	238
841 717	Petrol	1647	4	79.00	202	C1J 770	Petrol	1397	4	76.00	198
841.25	Petrol	1647	4	79.00	202	C1J 780	Petrol	1397	4	76.00	183
841.26	Petrol	1647	4	79.00	202	C1J 780	Petrol	1397	4	76.00	238
843 723	Petrol	1647	4	79.00	71	C1J 782	Petrol	1397	4	76.00	185
843 724	Petrol	1647	4	79.00	71	C1J 782	Petrol	1397	4	76.00	198
847 700	Petrol	1397	4	76.00	276	C1J 784	Petrol	1397	4	76.00	185
847 701	Petrol	1397	4	76.00	276	C1J 788	Petrol	1397	4	76.00	185
847 720	Petrol	1397	4	76.00	70	C1J 792	Petrol	1397	4	76.00	191
847 725	Petrol	1397	4	76.00	181	C1J 796	Petrol	1397	4	76.00	191
852 710	Diesel	2068	4	86.00	206	C2J 700	Petrol	1397	4	76.00	183
852 710	Diesel	2068	4	86.00	207	C2J 713	Petrol	1397	4	76.00	181
852 720	Diesel	2068	4	86.00	286	C2J 717	Petrol	1397	4	76.00	197
852 750	Diesel	2068	4	86.00	286	C2J 718	Petrol	1397	4	76.00	197
A1M 705	Petrol	1647	4	79.00	278	C2J 720	Petrol	1397	4	76.00	191
A1M 707	Petrol	1647	4	79.00	278	C2J 720	Petrol	1397	4	76.00	197
A1M 708	Petrol	1647	4	79.00	278	C2J 730	Petrol	1397	4	76.00	191
A2M 723	Petrol	1647	4	79.00	202	C2J 730	Petrol	1397	4	76.00	197
A5L 717	Petrol	1565	4	77.00	204	C2J 755	Petrol	1397	4	76.00	197
A5L 718	Petrol	1565	4	77.00	204	C2J 757	Petrol	1397	4	76.00	197
A5L 750	Petrol	1565	4	77.00	72	C2J 766	Petrol	1397	4	76.00	191
A6M 725	Petrol	1647	4	79.00	203	C2J 766	Petrol	1397	4	76.00	197
A6M 725	Petrol	1647	4	79.00	71	C2J 767	Petrol	1397	4	76.00	191
A6M 726	Petrol	1647	4	79.00	203	C2J 767	Petrol	1397	4	76.00	197
A6M 726	Petrol	1647	4	79.00	71	C2J 768	Petrol	1397	4	76.00	191

		CC			9			CC			9
C2J 768	Petrol	1397	4	76.00	197	E7J 635	Petrol	1390	4	75.80	85
C2J 770	Petrol	1397	4	76.00	219	E7J 706	Petrol	1390	4	75.80	212
C2J 772	Petrol	1397	4	76.00	211	E7J 710	Petrol	1390	4	75.80	14
C2J 780	Petrol	1397	4	76.00	183	E7J 711	Petrol	1390	4	75.80	14
C2J 781	Petrol	1397	4	76.00	183	E7J 718	Petrol	1390	4	75.80	15
C2J 782	Petrol	1397	4	76.00	183	E7J 719	Petrol	1390	4	75.80	15
C2J 784	Petrol	1397	4	76.00	183	E7J 720	Petrol	1390	4	75.80	239
C2J 784	Petrol	1397	4	76.00	238	E7J 724	Petrol	1390	4	75.80	239
C2J 788	Petrol	1397	4	76.00	183	E7J 726	Petrol	1390	4	75.80	239
C2J 789	Petrol	1397	4	76.00	183	E7J 728	Petrol	1390	4	75.80	239
C2J 798	Petrol	1397	4	76.00	183	E7J 742	Petrol	1390	4	75.80	212
C3G 700	Petrol	1239	4	74.00	291	E7J 754	Petrol	1390	4	75.80	15
C3G 702	Petrol	1239	4	74.00	291	E7J 756	Petrol	1390	4	75.80	15
C3G 710	Petrol	1239	4	74.00	237	E7J 757	Petrol	1390	4	75.80	15
C3G 712	Petrol	1239	4	74.00	237	E7J 764	Petrol	1390	4	75.80	137
C3G 720	Petrol	1239	4	74.00	9	E7J 764	Petrol	1390	4	75.80	138
C3J 700	Petrol	1397	4	76.00	183	E7J 773	Petrol	1390	4	75.80	239
C3J 700	Petrol	1397	4	76.00	238	E7J 780	Petrol	1390	4	75.80	16
C3J 702	Petrol	1397	4	76.00	183	E7J 780	Petrol	1390	4	75.80	85
C3J 702	Petrol	1397	4	76.00	238	F1N 720	Petrol	1721	4	81.00	279
C3J 710	Petrol	1397	4	76.00	210	F1N 722	Petrol	1721	4	81.00	279
C3J 710	Petrol	1397	4	76.00	211	F1N 724	Petrol	1721	4	81.00	279
C3J 760	Petrol	1397	4	76.00	183	F2N 700	Petrol	1721	4	81.00	194
C3J 760	Petrol	1397	4	76.00	238	F2N 700	Petrol	1721	4	81.00	200
C3J 762	Petrol	1397	4	76.00	238	F2N 704	Petrol	1721	4	81.00	194
C6J 750	Petrol	1397	4	76.00	182	F2N 704	Petrol	1721	4	81.00	200
D4F 702	Petrol	1149	4	69.00	293	F2N 708	Petrol	1721	4	81.00	194
D4F 704	Petrol	1149	4	69.00	293	F2N 708	Petrol	1721	4	81.00	200
D4F 708	Petrol	1149	4	69.00	294	F2N 710	Petrol	1721	4	81.00	194
D4F 712	Petrol	1149	4	69.00	11	F2N 710	Petrol	1721	4	81.00	200
D4F 712	Petrol	1149	4	69.00	84	F2N 710	Petrol	1721	4	81.00	220
D4F 714	Petrol	1149	4	69.00	11	F2N 712	Petrol	1721	4	81.00	213
D4F 714	Petrol	1149	4	69.00	84	F2N 712	Petrol	1721	4	81.00	220
D4F 716	Petrol	1149	4	69.00	84	F2N 724	Petrol	1721	4	81.00	213
D4F 740	Petrol	1149	4	69.00	12	F2N 728	Petrol	1721	4	81.00	213
D4F 740	Petrol	1149	4	69.00	13	F2N 730	Petrol	1721	4	81.00	194
D4F 740	Petrol	1149	4	69.00	164	F2N 730	Petrol	1721	4	81.00	200
D4F 764	Petrol	1149	4	69.00	12	F2N 732	Petrol	1721	4	81.00	200
D4F 764	Petrol	1149	4	69.00	13	F2N 740	Petrol	1721	4	81.00	187
D4F 764	Petrol	1149	4	69.00	164	F2N 742	Petrol	1721	4	81.00	187
D4F 772	Petrol	1149	4	69.00	295	F2N 742	Petrol	1721	4	81.00	200
D7F 700	Petrol	1149	4	69.00	292	F2N 750	Petrol	1721	4	81.00	220
D7F 701	Petrol	1149	4	69.00	292	F2N 752	Petrol	1721	4	81.00	220
D7F 702	Petrol	1149	4	69.00	292	F2N 770	Petrol	1721	4	81.00	27
D7F 703	Petrol	1149	4	69.00	292	F2N 798	Petrol	1721	4	81.00	194
D7F 704	Petrol	1149	4	69.00	292	F2N 798	Petrol	1721	4	81.00	200
D7F 706	Petrol	1149	4	69.00	292	F3N 702	Petrol	1721	4	81.00	187
D7F 710	Petrol	1149	4	69.00	8	F3N 708	Petrol	1721	4	81.00	194
D7F 710	Petrol	1149	4	69.00	83	F3N 708	Petrol	1721	4	81.00	200
D7F 720	Petrol	1149	4	69.00	8	F3N 716	Petrol	1721	4	81.00	187
D7F 720	Petrol	1149	4	69.00	83	F3N 717	Petrol	1721	4	81.00	187
D7F 722	Petrol	1149	4	69.00	8	F3N 718	Petrol	1721	4	81.00	194
D7F 722	Petrol	1149	4	69.00	83	F3N 718	Petrol	1721	4	81.00	200
D7F 726	Petrol	1149	4	69.00	8	F3N 722	Petrol	1721	4	81.00	187
D7F 726	Petrol	1149	4	69.00	83	F3N 722	Petrol	1721	4	81.00	220
D7F 730	Petrol	1149	4	69.00	8	F3N 723	Petrol	1721	4	81.00	220
D7F 744	Petrol	1149	4	69.00	83	F3N 726	Petrol	1721	4	81.00	220
D7F 746	Petrol	1149	4	69.00	83	F3N 740	Petrol	1721	4	81.00	213
E5F 710	Petrol	1171	4	75.80	10	F3N 741	Petrol	1721	4	81.00	213
E6J 700	Petrol	1390	4	75.80	212	F3N 742	Petrol	1721	4	81.00	213
E6J 701	Petrol	1390	4	75.80	212	F3N 742	Petrol	1721	4	81.00	214
E7F 700	Petrol	1171	4	75.80	7	F3N 743	Petrol	1721	4	81.00	213
E7F 706	Petrol	1171	4	75.80	7	F3N 743	Petrol	1721	4	81.00	214
E7F 708	Petrol	1171	4	75.80	7	F3N 746	Petrol	1721	4	81.00	213
E7F 750	Petrol	1171	4	75.80	7	F3P 670	Petrol	1794	4	82.70	96
E7J 624	Petrol	1390	4	75.80	137	F3P 678	Petrol	1794	4	82.70	96
E7J 626	Petrol	1390	4	75.80	137	F3P 682	Petrol	1783	4	82.70	215
E7J 626	Petrol	1390	4	75.80	138	F3P 700	Petrol	1794	4	82.70	215
E7J 634	Petrol	1390	4	75.80	85	F3P 704	Petrol	1794	4	82.70	215

		CC			9			CC			9
F3P 705	Petrol	1794	4	82.70	215	F4R 774	Petrol	1998	4	82.70	163
F3P 706	Petrol	1794	4	82.70	215	F4R 776	Petrol	1998	4	82.70	161
F3P 707	Petrol	1794	4	82.70	215	F4R 776	Petrol	1998	4	82.70	266
F3P 708	Petrol	1794	4	82.70	215	F4R 776	Petrol	1998	4	82.70	82
F3P 710	Petrol	1794	4	82.70	28	F4R 780	Petrol	1998	4	82.70	103
F3P 712	Petrol	1794	4	82.70	28	F4R 780	Petrol	1998	4	82.70	108
F3P 714	Petrol	1794	4	82.70	28	F4R 784	Petrol	1998	4	82.70	109
F3P 720	Petrol	1794	4	82.70	96	F4R 786	Petrol	1998	4	82.70	109
F3P 724	Petrol	1794	4	82.70	96	F4R 786	Petrol	1998	4	82.70	113
F3P 754	Petrol	1794	4	82.70	28	F4R 787	Petrol	1998	4	82.70	109
F3P 755	Petrol	1794	4	82.70	28	F4R 787	Petrol	1998	4	82.70	113
F3P 758	Petrol	1794	4	82.70	28	F4R 790	Petrol	1998	4	82.70	40
F3P 760	Petrol	1794	4	82.70	215	F4R 791	Petrol	1998	4	82.70	40
F3P 764	Petrol	1794	4	82.70	215	F4R 794	Petrol	1998	4	82.70	45
F3P 765	Petrol	1794	4	82.70	215	F4R 795	Petrol	1998	4	82.70	45
F3R 611	Petrol	1998	4	82.70	107	F4R 797	Petrol	1998	4	82.70	41
F3R 722	Petrol	1998	4	82.70	105	F4R 797	Petrol	1998	4	82.70	45
F3R 723	Petrol	1998	4	82.70	105	F4R 811	Petrol	1998	4	82.70	104
F3R 728	Petrol	1998	4	82.70	44	F4R 820	Petrol	1998	4	82.70	283
F3R 729	Petrol	1998	4	82.70	44	F4R 830	Petrol	1998	4	82.70	34
F3R 742	Petrol	1998	4	82.70	44	F4R 886	Petrol	1998	4	82.70	110
F3R 750	Petrol	1998	4	82.70	162	F4R 887	Petrol	1998	4	82.70	110
F3R 751	Petrol	1998	4	82.70	162	F4R 897	Petrol	1998	4	82.70	41
F3R 752	Petrol	1998	4	82.70	162	F5R 700	Petrol	1998	4	86.00	112
F3R 768	Petrol	1998	4	82.70	44	F5R 740	Petrol	1998	4	82.70	160
F3R 769	Petrol	1998	4	82.70	44	F7P 704	Petrol	1763	4	82.00	216
F3R 791	Petrol	1998	4	82.70	162	F7P 722	Petrol	1763	4	82.00	29
F3R 796	Petrol	1998	4	82.70	162	F7R 700	Petrol	1998	4	82.70	35
F4P 720	Petrol	1783	4	82.70	150	F7R 710	Petrol	1998	4	82.70	159
F4P 720	Petrol	1783	4	82.70	259	F7R 710	Petrol	1998	4	82.70	267
F4P 722	Petrol	1783	4	82.70	150	F7R 714	Petrol	1998	4	82.70	159
F4P 722	Petrol	1783	4	82.70	259	F8M 700	Diesel	1595	4	78.00	193
F4P 760	Petrol	1783	4	82.70	97	F8M 700	Diesel	1595	4	78.00	199
F4P 770	Petrol	1783	4	82.70	97	F8M 720	Diesel	1595	4	78.00	186
F4P 770	Petrol	1783	4	82.70	98	F8M 720	Diesel	1595	4	78.00	193
F4P 771	Petrol	1783	4	82.70	97	F8M 720	Diesel	1595	4	78.00	199
F4P 773	Petrol	1783	4	82.70	97	F8M 720	Diesel	1595	4	78.00	240
F4P 774	Petrol	1783	4	82.70	97	F8M 730	Diesel	1595	4	78.00	186
F4P 774	Petrol	1783	4	82.70	98	F8M 730	Diesel	1595	4	78.00	193
F4P 775	Petrol	1783	4	82.70	97	F8M 730	Diesel	1595	4	78.00	199
F4R 700	Petrol	1998	4	82.70	40	F8M 730	Diesel	1595	4	78.00	240
F4R 701	Petrol	1998	4	82.70	40	F8M 736	Diesel	1595	4	78.00	240
F4R 712	Petrol	1998	4	82.70	108	F8M 760	Diesel	1595	4	78.00	240
F4R 713	Petrol	1998	4	82.70	103	F8Q 606	Diesel	1870	4	80.00	280
F4R 713	Petrol	1998	4	82.70	108	F8Q 620	Diesel	1870	4	80.00	151
F4R 714	Petrol	1998	4	82.70	108	F8Q 622	Diesel	1870	4	80.00	151
F4R 715	Petrol	1998	4	82.70	108	F8Q 624	Diesel	1870	4	80.00	151
F4R 720	Petrol	1998	4	82.70	285	F8Q 630	Diesel	1870	4	80.00	31
F4R 722	Petrol	1998	4	82.70	285	F8Q 630	Diesel	1870	4	80.00	92
F4R 730	Petrol	1998	4	82.70	33	F8Q 632	Diesel	1870	4	80.00	92
F4R 738	Petrol	1998	4	82.70	274	F8Q 640	Diesel	1870	4	80.00	241
F4R 738	Petrol	1998	4	82.70	33	F8Q 662	Diesel	1870	4	80.00	31
F4R 740	Petrol	1998	4	82.70	265	F8Q 662	Diesel	1870	4	80.00	92
F4R 741	Petrol	1998	4	82.70	265	F8Q 678	Diesel	1870	4	80.00	30
F4R 744	Petrol	1998	4	82.70	265	F8Q 682	Diesel	1870	4	80.00	241
F4R 760	Petrol	1998	4	82.70	1	F8Q 706	Diesel	1870	4	80.00	217
F4R 761	Petrol	1998	4	82.70	1	F8Q 710	Diesel	1870	4	80.00	221
F4R 762	Petrol	1998	4	82.70	298	F8Q 722	Diesel	1870	4	80.00	241
F4R 763	Petrol	1998	4	82.70	298	F8Q 724	Diesel	1870	4	80.00	241
F4R 764	Petrol	1998	4	82.70	113	F8Q 730	Diesel	1870	4	80.00	30
F4R 765	Petrol	1998	4	82.70	113	F8Q 732	Diesel	1870	4	80.00	30
F4R 766	Petrol	1998	4	82.70	297	F8Q 740	Diesel	1870	4	80.00	218
F4R 767	Petrol	1998	4	82.70	297	F8Q 742	Diesel	1870	4	80.00	217
F4R 770	Petrol	1998	4	82.70	157	F8Q 744	Diesel	1870	4	80.00	218
F4R 770	Petrol	1998	4	82.70	265	F8Q 774	Diesel	1870	4	80.00	241
F4R 770	Petrol	1998	4	82.70	81	F8Q 776	Diesel	1870	4	80.00	241
F4R 771	Petrol	1998	4	82.70	157	F8Q 784	Diesel	1870	4	80.00	154
F4R 771	Petrol	1998	4	82.70	265	F8Q 786	Diesel	1870	4	80.00	154
F4R 771	Petrol	1998	4	82.70	81	F8Q 790	Diesel	1870	4	80.00	151

		CC			9			CC			9
F9Q 664	Diesel	1870	4	80.00	99	G9T 710	Diesel	2188	4	87.00	48
F9Q 674	Diesel	1870	4	80.00	99	G9T 712	Diesel	2188	4	87.00	2
F9Q 680	Diesel	1870	4	80.00	38	G9T 722	Diesel	2188	4	87.00	126
F9Q 710	Diesel	1870	4	80.00	102	G9T 742	Diesel	2188	4	87.00	48
F9Q 716	Diesel	1870	4	80.00	102	G9T 743	Diesel	2188	4	87.00	48
F9Q 717	Diesel	1870	4	80.00	102	G9U 720	Diesel	2463	4	89.00	128
F9Q 718	Diesel	1870	4	80.00	99	G9U 730	Diesel	2464	4	89.00	290
F9Q 722	Diesel	1870	4	80.00	39	G9U 754	Diesel	2463	4	89.00	128
F9Q 730	Diesel	1870	4	80.00	155	J5R 716	Petrol	1995	4	88.00	284
F9Q 731	Diesel	1870	4	80.00	155	J5R 718	Petrol	1995	4	88.00	123
F9Q 731	Diesel	1870	4	80.00	263	J5R 722	Petrol	1995	4	88.00	284
F9Q 732	Diesel	1870	4	80.00	152	J5R 726	Petrol	1995	4	88.00	284
F9Q 732	Diesel	1870	4	80.00	261	J5R 728	Petrol	1995	4	88.00	123
F9Q 733	Diesel	1870	4	80.00	152	J6R 234	Petrol	1995	4	88.00	42
F9Q 733	Diesel	1870	4	80.00	261	J6R 236	Petrol	1995	4	88.00	42
F9Q 734	Diesel	1870	4	80.00	155	J6R 706	Petrol	1995	4	88.00	227
F9Q 734	Diesel	1870	4	80.00	263	J6R 707	Petrol	1995	4	88.00	227
F9Q 736	Diesel	1870	4	80.00	155	J6R 716	Petrol	1995	4	88.00	205
F9Q 736	Diesel	1870	4	80.00	263	J6R 734	Petrol	1995	4	88.00	42
F9Q 740	Diesel	1870	4	80.00	261	J6R 758	Petrol	1995	4	88.00	222
F9Q 744	Diesel	1870	4	80.00	155	J6R 759	Petrol	1995	4	88.00	222
F9Q 744	Diesel	1870	4	80.00	263	J6R 760	Petrol	1995	4	88.00	227
F9Q 750	Diesel	1870	4	80.00	100	J6R 762	Petrol	1995	4	88.00	227
F9Q 750	Diesel	1870	4	80.00	99	J6R 763	Petrol	1995	4	88.00	227
F9Q 752	Diesel	1870	4	80.00	99	J6R 792	Petrol	1995	4	88.00	222
F9Q 754	Diesel	1870	4	80.00	99	J6R 793	Petrol	1995	4	88.00	222
F9Q 756	Diesel	1870	4	80.00	100	J7R 720	Petrol	1995	4	88.00	228
F9Q 756	Diesel	1870	4	80.00	99	J7R 721	Petrol	1995	4	88.00	228
F9Q 758	Diesel	1870	4	80.00	101	J7R 722	Petrol	1995	4	88.00	227
F9Q 759	Diesel	1870	4	80.00	101	J7R 723	Petrol	1995	4	88.00	227
F9Q 760	Diesel	1870	4	80.00	281	J7R 726	Petrol	1995	4	88.00	228
F9Q 762	Diesel	1870	4	80.00	281	J7R 732	Petrol	1995	4	88.00	243
F9Q 770	Diesel	1870	4	80.00	122	J7R 733	Petrol	1995	4	88.00	243
F9Q 772	Diesel	1870	4	80.00	121	J7R 734	Petrol	1995	4	88.00	244
F9Q 780	Diesel	1870	4	80.00	32	J7R 735	Petrol	1995	4	88.00	244
F9Q 780	Diesel	1870	4	80.00	91	J7R 740	Petrol	1995	4	88.00	223
F9Q 782	Diesel	1870	4	80.00	91	J7R 746	Petrol	1995	4	88.00	222
F9Q 790	Diesel	1870	4	80.00	91	J7R 747	Petrol	1995	4	88.00	222
F9Q 800	Diesel	1870	4	80.00	152	J7R 750	Petrol	1995	4	88.00	222
F9Q 803	Diesel	1870	4	80.00	153	J7R 751	Petrol	1995	4	88.00	222
F9Q 803	Diesel	1870	4	80.00	262	J7R 752	Petrol	1995	4	88.00	224
F9Q 804	Diesel	1870	4	80.00	153	J7R 756	Petrol	1995	4	88.00	224
F9Q 804	Diesel	1870	4	80.00	262	J7R 760	Petrol	1995	4	88.00	43
F9Q 808	Diesel	1870	4	80.00	152	J7R 768	Petrol	1995	4	88.00	43
F9Q 812	Diesel	1870	4	80.00	260	J7T 600	Petrol	2165	4	88.00	287
F9Q 812	Diesel	1870	4	80.00	262	J7T 706	Petrol	2165	4	88.00	231
F9Q 812	Diesel	1870	4	80.00	78	J7T 707	Petrol	2165	4	88.00	231
F9Q 816	Diesel	1870	4	80.00	153	J7T 708	Petrol	2165	4	88.00	231
F9Q 816	Diesel	1870	4	80.00	79	J7T 714	Petrol	2165	4	88.00	231
F9Q 818	Diesel	1870	4	80.00	153	J7T 715	Petrol	2165	4	88.00	231
F9Q 818	Diesel	1870	4	80.00	79	J7T 730	Petrol	2165	4	88.00	231
F9Q 820	Diesel	1870	4	80.00	38	J7T 731	Petrol	2165	4	88.00	231
F9Q 826	Diesel	1870	4	80.00	38	J7T 732	Petrol	2165	4	88.00	231
G8T 706	Diesel	2188	4	87.00	114	J7T 733	Petrol	2165	4	88.00	231
G8T 714	Diesel	2188	4	87.00	50	J7T 754	Petrol	2165	4	88.00	226
G8T 716	Diesel	2188	4	87.00	50	J7T 755	Petrol	2165	4	88.00	226
G8T 740	Diesel	2188	4	87.00	249	J7T 760	Petrol	2165	4	88.00	248
G8T 752	Diesel	2188	4	87.00	114	J7T 761	Petrol	2165	4	88.00	248
G8T 760	Diesel	2188	4	87.00	117	J7T 762	Petrol	2165	4	88.00	247
G8T 760	Diesel	2188	4	87.00	50	J7T 770	Petrol	2165	4	88.00	49
G8T 790	Diesel	2188	4	87.00	114	J7T 772	Petrol	2165	4	88.00	49
G8T 794	Diesel	2188	4	87.00	114	J7T 773	Petrol	2165	4	88.00	49
G9T 600	Diesel	2188	4	87.00	116	J7T 776	Petrol	2165	4	88.00	49
G9T 600	Diesel	2188	4	87.00	300	J7T 780	Petrol	2165	4	88.00	287
G9T 645	Diesel	2188	4	87.00	51	J7T 782	Petrol	2165	4	88.00	125
G9T 700	Diesel	2188	4	87.00	115	J7T 788	Petrol	2165	4	88.00	125
G9T 700	Diesel	2188	4	87.00	300	J8S 240	Diesel	2068	4	86.00	46
G9T 702	Diesel	2188	4	87.00	115	J8S 330	Diesel	2068	4	86.00	124
G9T 702	Diesel	2188	4	87.00	299	J8S 600	Diesel	2068	4	86.00	225

		CC			9			CC			9
J8S 610	Diesel	2068	4	86.00	47	K4M 790	Petrol	1598	4	79.50	170
J8S 612	Diesel	2068	4	86.00	46	K4M 791	Petrol	1598	4	79.50	170
J8S 620	Diesel	2068	4	86.00	286	K4M 792	Petrol	1598	4	79.50	169
J8S 702	Diesel	2068	4	86.00	234	K4M 794	Petrol	1598	4	79.50	169
J8S 704	Diesel	2068	4	86.00	225	K4M 800	Petrol	1598	4	79.50	24
J8S 706	Diesel	2068	4	86.00	229	K4M 800	Petrol	1598	4	79.50	26
J8S 708	Diesel	2068	4	86.00	230	K4M 801	Petrol	1598	4	79.50	26
J8S 711	Diesel	2068	4	86.00	206	K4M 804	Petrol	1598	4	79.50	24
J8S 711	Diesel	2068	4	86.00	207	K7J 701	Petrol	1390	4	79.50	85
J8S 712	Diesel	2068	4	86.00	74	K7J700	Petrol	1390	4	79.50	268
J8S 714	Diesel	2068	4	86.00	225	K7J700	Petrol	1390	4	79.50	85
J8S 736	Diesel	2068	4	86.00	229	K7M 702	Petrol	1598	4	79.50	149
J8S 738	Diesel	2068	4	86.00	230	K7M 703	Petrol	1598	4	79.50	149
J8S 740	Diesel	2068	4	86.00	225	K7M 720	Petrol	1598	4	79.50	149
J8S 758	Diesel	2068	4	86.00	286	K7M 744	Petrol	1598	4	79.50	25
J8S 760	Diesel	2068	4	86.00	246	K7M 745	Petrol	1598	4	79.50	25
J8S 772	Diesel	2068	4	86.00	47	K7M 790	Petrol	1598	4	79.50	149
J8S 774	Diesel	2068	4	86.00	46	K9K 700	Diesel	1461	4	76.00	18
J8S 776	Diesel	2068	4	86.00	47	K9K 700	Diesel	1461	4	76.00	20
J8S 778	Diesel	2068	4	86.00	47	K9K 700	Diesel	1461	4	76.00	270
J8S 784	Diesel	2068	4	86.00	225	K9K 700	Diesel	1461	4	76.00	86
J8S 786 (KAT)	Diesel	2068	4	86.00	225	K9K 702	Diesel	1461	4	76.00	18
J8S 788	Diesel	2068	4	86.00	225	K9K 702	Diesel	1461	4	76.00	270
K4J 700	Petrol	1390	4	79.50	17	K9K 702	Diesel	1461	4	76.00	272
K4J 712	Petrol	1390	4	79.50	17	K9K 702	Diesel	1461	4	76.00	86
K4J 712	Petrol	1390	4	79.50	269	K9K 704	Diesel	1461	4	76.00	18
K4J 713	Petrol	1390	4	79.50	17	K9K 704	Diesel	1461	4	76.00	20
K4J 714	Petrol	1390	4	79.50	136	K9K 704	Diesel	1461	4	76.00	86
K4J 714	Petrol	1390	4	79.50	252	K9K 710	Diesel	1461	4	76.00	18
K4J 730	Petrol	1390	4	79.50	135	K9K 710	Diesel	1461	4	76.00	86
K4J 730	Petrol	1390	4	79.50	136	K9K 712	Diesel	1461	4	76.00	19
K4J 730	Petrol	1390	4	79.50	252	K9K 714	Diesel	1461	4	76.00	18
K4J 732	Petrol	1390	4	79.50	134	K9K 714	Diesel	1461	4	76.00	271
K4J 732	Petrol	1390	4	79.50	136	K9K 714	Diesel	1461	4	76.00	87
K4J 750	Petrol	1390	4	79.50	136	K9K 716	Diesel	1461	4	76.00	18
K4J 750	Petrol	1390	4	79.50	252	K9K 718	Diesel	1461	4	76.00	18
K4J 770	Petrol	1390	4	79.50	165	K9K 718	Diesel	1461	4	76.00	87
K4J 780	Petrol	1390	4	79.50	17	K9K 722	Diesel	1461	4	76.00	139
K4M 700	Petrol	1598	4	79.50	147	K9K 722	Diesel	1461	4	76.00	141
K4M 700	Petrol	1598	4	79.50	258	K9K 722	Diesel	1461	4	76.00	142
K4M 701	Petrol	1598	4	79.50	147	K9K 722	Diesel	1461	4	76.00	253
K4M 701	Petrol	1598	4	79.50	258	K9K 722	Diesel	1461	4	76.00	255
K4M 704	Petrol	1598	4	79.50	147	K9K 724	Diesel	1461	4	76.00	144
K4M 704	Petrol	1598	4	79.50	258	K9K 724	Diesel	1461	4	76.00	255
K4M 708	Petrol	1598	4	79.50	147	K9K 728	Diesel	1461	4	76.00	140
K4M 708	Petrol	1598	4	79.50	23	K9K 728	Diesel	1461	4	76.00	143
K4M 708	Petrol	1598	4	79.50	257	K9K 728	Diesel	1461	4	76.00	254
K4M 708	Petrol	1598	4	79.50	258	K9K 728	Diesel	1461	4	76.00	75
K4M 709	Petrol	1598	4	79.50	257	K9K 729	Diesel	1461	4	76.00	143
K4M 710	Petrol	1598	4	79.50	94	K9K 729	Diesel	1461	4	76.00	144
K4M 711	Petrol	1598	4	79.50	94	K9K 729	Diesel	1461	4	76.00	254
K4M 714	Petrol	1598	4	79.50	94	K9K 729	Diesel	1461	4	76.00	255
K4M 716	Petrol	1598	4	79.50	95	K9K 729	Diesel	1461	4	76.00	75
K4M 720	Petrol	1598	4	79.50	94	K9K 729	Diesel	1461	4	76.00	76
K4M 724	Petrol	1598	4	79.50	94	K9K 732	Diesel	1461	4	76.00	145
K4M 740	Petrol	1598	4	79.50	273	K9K 732	Diesel	1461	4	76.00	256
K4M 746	Petrol	1598	4	79.50	23	K9K 734	Diesel	1461	4	76.00	145
K4M 748	Petrol	1598	4	79.50	23	K9K 740	Diesel	1461	4	76.00	18
K4M 750	Petrol	1598	4	79.50	89	K9K 740	Diesel	1461	4	76.00	272
K4M 752	Petrol	1598	4	79.50	89	K9K 740	Diesel	1461	4	76.00	296
K4M 753	Petrol	1598	4	79.50	89	K9K 750	Diesel	1461	4	76.00	18
K4M 760	Petrol	1598	4	79.50	146	K9K 752	Diesel	1461	4	76.00	168
K4M 760	Petrol	1598	4	79.50	148	K9K 752	Diesel	1461	4	76.00	18
K4M 761	Petrol	1598	4	79.50	146	K9K 760	Diesel	1461	4	76.00	271
K4M 761	Petrol	1598	4	79.50	148	K9K 762	Diesel	1461	4	76.00	271
K4M 761	Petrol	1598	4	79.50	257	K9K 764	Diesel	1461	4	76.00	168
K4M 761	Petrol	1598	4	79.50	77	K9K 764	Diesel	1461	4	76.00	19
K4M 782	Petrol	1598	4	79.50	257	K9K 764	Diesel	1461	4	76.00	22
K4M 782	Petrol	1598	4	79.50	77	K9K 766	Diesel	1461	4	76.00	167



CC



9



CC



9

K9K 766	Diesel	1461	4	76.00	19
K9K 766	Diesel	1461	4	76.00	22
K9K 768	Diesel	1461	4	76.00	166
K9K 768	Diesel	1461	4	76.00	19
K9K 768	Diesel	1461	4	76.00	22
K9K 768	Diesel	1461	4	76.00	271
K9K 780	Diesel	1461	4	76.00	93
K9K 792	Diesel	1461	4	76.00	120
K9K 792	Diesel	1461	4	76.00	271
K9K 800	Diesel	1461	4	76.00	88
K9K 802	Diesel	1461	4	76.00	88
K9K 804	Diesel	1461	4	76.00	88
K9K 806	Diesel	1461	4	76.00	88
K9K 840	Diesel	1461	4	76.00	271
L7X 700	Petrol	2946	6	87.00	118
L7X 701	Petrol	2946	6	87.00	118
L7X 713	Petrol	2946	6	87.00	251
L7X 720	Petrol	2946	6	87.00	3
L7X 721	Petrol	2946	6	87.00	3
L7X 727	Petrol	2946	6	87.00	54
L7X 731	Petrol	2946	6	87.00	119
L7X 760	Petrol	2946	6	87.00	37
L7X 762	Petrol	2946	6	87.00	275
L7X 762	Petrol	2946	6	87.00	36
M9R 700	Diesel	1995	4	84.00	156
M9R 700	Diesel	1995	4	84.00	264
M9R 700	Diesel	1995	4	84.00	80
M9R 780	Diesel	1995	4	84.00	282
N7Q 700	Petrol	1948	4	83.00	111
N7Q 704	Petrol	1948	4	83.00	111
N7Q 710	Petrol	1948	4	83.00	245
N7Q 711	Petrol	1948	4	83.00	245
P9X 701	Diesel	2958	6	87.50	301
P9X 701	Diesel	2958	6	87.50	53
S8U 720	Diesel	2445	4	93.00	288
S8U 722	Diesel	2445	4	93.00	288
S8U 731	Diesel	2445	4	93.00	127
S8U 731	Diesel	2445	4	93.00	130
S8U 742	Diesel	2499	4	93.00	129
S8U 762	Diesel	2445	4	93.00	250
S8U 763	Diesel	2499	4	93.00	250
S9U 702	Diesel	2499	4	93.00	131
S9U 714	Diesel	2499	4	93.00	131
S9W 702	Diesel	2799	4	94.40	132
V4Y 701	Petrol	3498	6	95.50	302
V4Y 711	Petrol	3498	6	95.50	55
V4Y 715	Petrol	3498	6	95.50	55
Z7V 708	Petrol	2664	6	88.00	232
Z7V 709	Petrol	2664	6	88.00	232
Z7V 711	Petrol	2664	6	88.00	232
Z7W 700	Petrol	2849	6	91.00	233
Z7W 702	Petrol	2849	6	91.00	233
Z7W 706	Petrol	2849	6	91.00	233
Z7W 707	Petrol	2849	6	91.00	233
Z7W 709	Petrol	2849	6	91.00	233
Z7W 712	Petrol	2849	6	91.00	52
Z7W 713	Petrol	2849	6	91.00	52
Z7W 717	Petrol	2849	6	91.00	52

Type Mines OU C.N.I.T.*	Encadré N°	Type Mines OU C.N.I.T.*	Encadré N°	Type Mines OU C.N.I.T.*	Encadré N°	Type Mines OU C.N.I.T.*	Encadré N°
Avantime		B57A05A	7	BB0U0F	32	BR11	12
DE01	2	B57ABC	7	BB0V	32	BR15	26
DE0106	2	B57B01	14	BB0W	11	BR1A	18
DE04	3	B57B02	14	BB0WEH	11	BR1A0H	17
DE0T	3	B57B05	14	BB10	8	BR1B	18
DE0T02	3	B57B05A	14	BB11	11	BR1B0A	26
DE0T06	3	B57BB1	14	BB13	17	BR1B0H	26
DE0U	1	B57BB5	14	BB14	23	BR1C	21
DE0U02	1	B57BB8	14	BB17	16	BR1D	12
DE0U06	1	B57BK1	14	BB19	11	BR1E	17
DE0V	1	B57BK2	14	BB1D0F	23	BR1E05	12
DE0V06	1	B57BK5	14	BB1DEA	23	BR1F	18
MRE1711PR100	1	B57C05	28	BB1DEF	23	BR1F05	19
MRE1711PS101	1	B57C05A	28	BB1J	23	BR1F0H	19
MRE1901P8946	3	B57CB5	28	BB1K	8	BR1G	18
MRE1911PA099	3	B57CBC	28	BB1KEF	8	BR1G0H	19
MRE3911PY142	3	B57I05	30	BB1L	17	BR1H06	19
MRE3911PZ143	3	B57IB5	30	BB1LOF	17	BR1J	26
MRE5611P1144	2	B57J01	15	BB1LEA	17	BR1J0H	12
Clio		B57J05	15	BB1LEF	17	BR1JBH	12
35700000	28	B57L05	30	BB1R	23	BR1L	12
357A02	28	B57N04	10	BB1W	18	BR1M	26
357D02	28	B57N05	10	BB24	18	BR1N	19
357D02A	28	B57P05	14	BB26	23	BR1R0H	12
357F04	7	B57R05	7	BB27	11	BR1T	19
357F05	7	B57S04	7	BB28	8	BR1U	13
357G05	7	B57S05	7	BB2C	32	BR1Y	26
357J05	7	B57T	15	BB2D	8	BR2C06	21
357K05	8	B57T01	15	BB2DEF	8	BR2N06	19
357K0C	8	B57T05	15	BB2G	19	BRA0T6	17
357K0F	8	B57U05	28	BB2G05	19	BRAC06	21
357L05	7	B57Y05	14	BB2H	8	BRAN06	19
357N05	30	BB00	25	BB2J	18	BRCB0A	26
357U02	28	BB000F	25	BB2J05	18	BRCF05	19
357U05	28	BB01	23	BB2K	23	BRCF0H	19
357V05	28	BB02	31	BB2T	11	BRCH06	19
357Y05	8	BB020F	31	BB2T05	11	BREU0H	13
557A02	28	BB05	11	BB2U	11	BREUBH	13
557B05	15	BB05CF	11	BB2U05	11	BROV	18
557D02	28	BB07	18	BB2V	11	C57105	6
557D02A	28	BB07CF	18	BB3AOC	8	C57204	10
557F04	7	BB07EF	18	BB3A0F	8	C57205	10
557F05	7	BB08	18	BB3E	23	C57205A	10
557G05	7	BB080F	18	BB3G	23	C57301	14
557J05	7	BB08EF	18	BB3H	23	C57305	14
557K05	8	BBOA	8	BB3KCF	8	C57305A	14
557K0C	8	BBOAOC	8	BB3KEF	8	C57405	27
557K0F	8	BBOA0F	8	BB3M	18	C57405A	27
557L05	7	BBOB	8	BB3M05	18	C57505	29
557N05	30	BBOB0F	8	BB3N	18	C57605	30
557R05	7	BB0C	16	BB3N05	18	C576B5	30
557U02	28	BB0C0F	16	BBR7CF	18	C57705	9
557U05	28	BB0D	25	BBR7EF	18	C57802	28
557U0C	28	BB0DOA	25	BBTJ05	18	C57905	28
557Y	8	BB0D0F	25	BR00	17	C57A04	7
557Y05	8	BBOE	31	BR01	12	C57A05	7
657K05	8	BBOE0E	31	BR02	12	C57A05A	7
657K0F	8	BBOE0F	31	BR03	12	C57AB5	7
B57105	6	BBOF	8	BR05	26	C57ABC	7
B57204	10	BBOFCF	8	BR09	24	C57AK5	7
B57205	10	BBOH	23	BR0A	17	C57B01	14
B57205A	10	BBOH0F	23	BR0B	26	C57B02	14
B57301	14	BB0J	31	BROE	12	C57B05	14
B57305	14	BB0JOE	31	BROF	19	C57B05A	14
B57405	27	BB0J0F	31	BROG	19	C57BB1	14
B57405A	27	BB0L	17	BR0H	19	C57BB5	14
B57605	30	BB0LOA	17	BROJ	12	C57BK1	14
B57605A	30	BB0LOF	17	BROQ	12	C57BK5	14
B576B5	30	BBOP	17	BROR	12	C57C05	28
B57705	9	BBOPEA	17	BR0S	12	C57C05A	28
B57802	28	BBOPEG	17	BROT	24	C57CB5	28
B57A04	7	BB0S	16	BROU	24	C57D05	29
B57A05	7	BB0SOA	16	BROV	18	C57H05	28
		BB0SOF	16	BROW	18	C57HB5	28
		BB0T	23	BROY	26	C57I05	30

* C.N.I.T. = Code National d'Identification du Type (code D2.1 sur nouvelles cartes grises)

Type Mines OU C.N.I.T.*	Encadré N°	Type Mines OU C.N.I.T.*	Encadré N°	Type Mines OU C.N.I.T.*	Encadré N°	Type Mines OU C.N.I.T.*	Encadré N°
C57IB5	30	CB1G	33	CR1F05	19	M10RENV0000E126	13
C57J01	15	CB1H	36	CR1F0H	19	M10RENV0000H032	12
C57J05	15	CB1K	8	CR1G	18	M10RENV0000L072	24
C57J0E	15	CB1KEF	8	CR1G0H	19	M10RENV0000M001	24
C57L05	30	CB1L	17	CR1H06	19	M10RENV0000M073	17
C57M05	35	CB1LOF	17	CR1J	26	M10RENV0000M098	24
C57R04	7	CB1LEA	17	CR1J0H	12	M10RENV0000N002	17
C57R05	7	CB1LEF	17	CR1JBH	12	M10RENV0000N038	12
C57S04	7	CB1NOF	33	CR1L	12	M10RENV0000N099	24
C57S05	7	CB1S	33	CR1M	26	M10RENV0000P003	26
C57T02	15	CB1T	33	CR1N	19	M10RENV0000P004	26
C57T05	15	CB1U	36	CR1N06	34	M10RENV0000P075	26
C57T05A	15	CB1W	18	CR1Q0H	12	M10RENV0000P100	13
C57U05	28	CB20	33	CR1ROH	12	M10RENV0000P101	13
C57Y05	14	CB21	33	CR1T	19	M10RENV0000R005	12
CB01	23	CB220F	33	CR1U	13	M10RENV0000R006	12
CB05	11	CB26	23	CR1Y	26	M10RENV0000R782	26
CB05CF	11	CB27	11	CR1Y0A	26	M10RENV0000S043	12
CB05EF	11	CB2C	32	CR1Y0H	26	M10RENV0000S079	12
CB07	18	CB2D	8	CR2C06	21	M10RENV0000U106	13
CB07CF	18	CB2DEF	8	CR2D0H	12	M10RENV0000V107	13
CB07EF	18	CB2G	19	CR2E0H	17	M10RENV0000W011	12
CB080F	18	CB2G05	19	CR2J0A	26	M10RENV0000W047	24
CB08EF	18	CB2H	8	CR2N06	19	M10RENV0000X012	12
CB0A	8	CB2J	18	CRAC06	21	M10RENV0000X048	17
CB0A0C	8	CB2J05	18	CRC90H	24	M10RENV0000Y085	12
CB0A0F	8	CB2P	33	CRCB0A	26	M10RENV0000Z014	12
CB0B	16	CB2T	11	CRCF05	19	M10RENV0000Z050	26
CB0B0F	8	CB2T05	11	CRCF0H	19	MRE000AE7790	8
CB0C	16	CB2U	11	CRCH06	19	MRE000AE8791	8
CB0C0F	16	CB2U05	11	CREU0H	13	MRE000AE9792	8
CB0D	25	CB2V	11	CREUBH	13	MRE000AEA793	8
CB0D0A	25	CB3A0C	8	KR02	13	MRE000AEG580	8
CB0D0F	25	CB3A0F	8	KR0A	17	MRE000AEH412	30
CB0E	31	CB3E	23	KR0B	24	MRE000AEJ802	14
CB0E0E	31	CB3G	23	KR0E	13	MRE000AEK803	14
CB0E0F	31	CB3H	23	KR0F	22	MRE000AEL804	14
CB0F	8	CB3KEF	8	KR0G	22	MRE000AEM805	14
CB0FCF	8	CB3M	18	KR0H	22	MRE000AEP807	14
CB0H	23	CB3N	18	KR0J	13	MRE000AET266	8
CB0H0F	23	CBBM05	18	KR1A0H	17	MRE000AEW269	8
CB0J	31	CBBN05	18	KR1B0A	24	MRE000AEY817	30
CB0J0E	31	CBCJ05	18	KR1B0H	24	MRE000AEZ818	30
CB0J0F	31	CBCU05	11	KR1E05	13	MRE001AE0139	8
CB0L	17	CBR7EF	18	KR1F05	22	MRE001AE0466	14
CB0LOA	17	CR00	17	KR1F0H	22	MRE001AE1140	8
CB0LOF	17	CR02	12	KR1G0H	22	MRE001AE1467	14
CB0M	33	CR03	12	KR1H06	22	MRE001AE2141	8
CB0M0F	33	CR05	26	KR1J0H	13	MRE001AE2468	25
CB0P	17	CR09	24	KR1N	22	MRE001AE3142	8
CB0POG	17	CR0A	17	KR1U	13	MRE001AE3469	25
CB0PEG	17	CR0B	26	KRCF05	22	MRE001AE4046	15
CB0S	16	CR0E	12	KRCF0H	22	MRE001AE4143	14
CB0S0F	16	CR0F	19	KRCH06	22	MRE001AE4337	8
CB0T	23	CR0G	19	LB00	25	MRE001AE4470	31
CB0T0F	23	CR0H	19	LB02	31	MRE001AE5144	14
CB0U	32	CR0J	12	LB03	16	MRE001AE5338	8
CB0U0F	32	CR0N	34	M10RENV00000015	12	MRE001AE5471	31
CB0V	32	CR0Q	12	M10RENV00000051	12	MRE001AE6145	25
CB0W	11	CR0R	12	M10RENV00001052	12	MRE001AE6339	8
CB0WOH	11	CR0S	12	M10RENV00003090	12	MRE001AE6472	31
CB0WEH	11	CR0T	24	M10RENV00003769	24	MRE001AE7146	25
CB10	8	CR0U	24	M10RENV00006057	12	MRE001AE7340	8
CB11	11	CR0V	18	M10RENV00007022	21	MRE001AE7473	31
CB13	17	CR0Y	26	M10RENV00007058	12	MRE001AE8147	31
CB14	23	CR11	12	M10RENV00007119	24	MRE001AE8341	14
CB15	33	CR15	26	M10RENV00008120	24	MRE001AE9148	31
CB17	16	CR190H	24	M10RENV00009121	13	MRE001AE9342	14
CB19	11	CR1A0H	17	M10RENV0000A025	24	MRE001AEA149	31
CB1A	37	CR1B0A	26	M10RENV0000A061	12	MRE001AEA343	25
CB1A06	37	CR1B0H	26	M10RENV0000B026	17	MRE001AEA476	25
CB1C	33	CR1C	21	M10RENV0000B062	12	MRE001AEB150	31
CB1D0F	23	CR1E	17	M10RENV0000C027	26	MRE001AEB344	25
CB1DEA	23	CR1E05	12	M10RENV0000C803	26	MRE001AEB477	25
CB1DEF	23	CR1EB5	12	M10RENV0000D028	26	MRE001AEC345	31

* C.N.I.T. = Code National d'Identification du Type (code D2.1 sur nouvelles cartes grises)

Type Mines OU C.N.I.T.*	Encadré N°	Type Mines OU C.N.I.T.*	Encadré N°	Type Mines OU C.N.I.T.*	Encadré N°	Type Mines OU C.N.I.T.*	Encadré N°
MRE001AED346	31	MRE1132EL549	12	MRE3101EQ032	15	MRE5022EU133	18
MRE001AEE347	31	MRE1132ET194	12	MRE3102ET712	15	MRE5022EV752	19
MRE001AEF348	31	MRE1132EU195	13	MRE3201E0359	25	MRE5022EW559	19
MRE001AEJ352	25	MRE1134EJ640	13	MRE3201EL696	25	MRE5024EJ929	22
MRE001AEW462	8	MRE1201E7045	25	MRE3202E0357	25	MRE5031E3592	19
MRE001AEX463	8	MRE1201EE731	25	MRE3202ES701	25	MRE5032EL547	19
MRE001AEY464	8	MRE1202E3039	25	MRE3301E0798	17	MRE5034EJ638	22
MRE001AEZ465	8	MRE1202EN023	28	MRE3301E3898	17	MRE5034EP317	22
MRE1001E5997	8	MRE1211ER998	24	MRE3302E1797	17	MRE5101E3912	32
MRE1001ED362	8	MRE1212EQ995	24	MRE3302E4897	17	MRE5101EW711	32
MRE1001EF001	8	MRE1221E0000	24	MRE3311E1482	23	MRE5102E4911	32
MRE1001EF910	8	MRE1221E9566	24	MRE3311E2483	23	MRE5102EX710	32
MRE1001EG002	8	MRE1221EG573	24	MRE3311EA031	17	MRE5111EF474	18
MRE1001EH003	8	MRE1222E5560	24	MRE3311EB262	17	MRE5111EG475	18
MRE1001EK042	8	MRE1222EY553	24	MRE3311EC033	23	MRE5111EK576	18
MRE1001EL043	8	MRE1301EA365	23	MRE3311EG486	17	MRE5111EM578	18
MRE1002E6996	8	MRE1301EA778	17	MRE3311EX478	17	MRE5111ET125	18
MRE1002ED360	8	MRE1301EJ859	23	MRE3312EB030	17	MRE5111EU029	18
MRE1002EG036	8	MRE1301EJ980	23	MRE3312EC261	17	MRE5112EL575	18
MRE1002EG909	8	MRE1301EL861	17	MRE3312ED032	23	MRE5112EN577	18
MRE1002EH037	8	MRE1302EB777	17	MRE3312EF458	17	MRE5112EU124	18
MRE1002EW016	8	MRE1302EJ979	23	MRE3312EG459	17	MRE5112EV028	18
MRE1002EX017	8	MRE1302EK858	23	MRE3312EK463	23	MRE5112EX454	18
MRE1011E7064	8	MRE1302EM860	17	MRE3312EL464	23	MRE5112EY455	18
MRE1011EF485	8	MRE1311EA001	17	MRE3312EP468	17	MRE5211EK979	19
MRE1011EW477	8	MRE1311EB487	17	MRE3312EQ469	17	MRE5211EP984	19
MRE1012E8063	8	MRE1311EG977	17	MRE3421E1011	23	MRE5212ED970	19
MRE1012EE457	8	MRE1311EL982	17	MRE3421E1568	26	MRE5212EJ975	19
MRE1012EP467	8	MRE1311EQ017	17	MRE3421E2012	23	MRE5221ED389	18
MRE1021E4387	12	MRE1311ES479	17	MRE3421E8575	26	MRE5221EF391	19
MRE1021EQ761	12	MRE1311EX484	23	MRE3422E1009	23	MRE5221EQ571	19
MRE1021EZ055	12	MRE1311EZ062	23	MRE3422E2010	23	MRE5221ET768	19
MRE1022EM755	12	MRE1312E0061	23	MRE3422EQ555	26	MRE5221EU769	19
MRE1022EZ053	12	MRE1312EB000	17	MRE3422EX562	26	MRE5221EX578	19
MRE1022EZ380	12	MRE1312EB460	17	MRE3424EA923	24	MRE5222EF558	19
MRE1101E3960	11	MRE1312EE973	17	MRE3432E1565	26	MRE5222EM565	19
MRE1101E6927	11	MRE1312EG465	23	MRE3432ED541	26	MRE5222ET766	18
MRE1101E9894	16	MRE1312EH466	23	MRE3434EB632	24	MRE5222EU767	19
MRE1101EJ613	14	MRE1312EL470	17	MRE3434EK120	24	MRE5222EX382	19
MRE1101ES974	11	MRE1312ER016	17	MRE3434EW653	24	MRE5222EZ384	19
MRE1101EU976	11	MRE1312ES599	17	MRE5001E0046	31	MRE5224E1928	22
MRE1101EW044	14	MRE1312EY968	17	MRE5001E1047	31	MRE5224E8935	22
MRE1102E3013	14	MRE1321E5552	17	MRE5001E2727	31	MRE5231ED618	19
MRE1102E4959	11	MRE1321EK567	17	MRE5001E4729	31	MRE5231EM591	19
MRE1102E7926	11	MRE1321ER574	17	MRE5001E9698	31	MRE5232E4546	19
MRE1102EA893	16	MRE1322E6551	17	MRE5001EB700	31	MRE5232EU572	19
MRE1102EJ029	14	MRE1322E9554	17	MRE5001ED896	18	MRE5234E2637	22
MRE1102EK612	14	MRE1322EG561	17	MRE5001EJ999	18	MRE5234E9123	22
MRE1102ES038	14	MRE1411ER978	23	MRE5001EV005	31	MRE5234EM657	22
MRE1102ET973	11	MRE1411EW983	23	MRE5002E3726	31	MRE5311E0985	19
MRE1102EV975	11	MRE1412E9969	23	MRE5002E5728	31	MRE5311E1476	19
MRE1111E0981	11	MRE1412EP974	23	MRE5002EA697	31	MRE5311EV980	19
MRE1111E1472	11	MRE1421E3504	26	MRE5002EB019	31	MRE5312EJ456	19
MRE1111EA481	11	MRE1421E3576	26	MRE5002EC699	31	MRE5312EP971	19
MRE1111EF741	11	MRE1421E7508	26	MRE5002EE895	18	MRE5312ET976	19
MRE1111EG742	11	MRE1421EW569	26	MRE5002EK998	18	MRE5321EM388	19
MRE1111EL068	11	MRE1422E0499	26	MRE5002EW040	31	MRE5321EP390	19
MRE1111EL650	11	MRE1422E3502	26	MRE5002EX041	31	MRE5322E6381	19
MRE1111EM651	11	MRE1422EL556	26	MRE5011E4473	18	MRE5322E8383	19
MRE1111ES682	11	MRE1422ES563	26	MRE5011E7573	18	MRE5324EH934	22
MRE1112EF678	12	MRE1424E5924	24	MRE5011E8574	18	MRE5331EP620	19
MRE1112EF739	12	MRE1432EW566	26	MRE5011EK999	18	MRE5332E6574	19
MRE1112EG740	12	MRE1434E6633	24	MRE5012E8572	18	MRE5332EG548	19
MRE1112EJ451	12	MRE1434EF121	24	MRE5012EJ996	18	MRE5334EC116	22
MRE1112EL648	11	MRE1434ER654	24	MRE5012EL452	18	MRE5334EE639	22
MRE1112EM067	11	MRE1701EE753	33	MRE5012EM453	18	MRE5334EJ644	22
MRE1112EM649	12	MRE1701EG913	33	MRE5021E7572	19	MRE5334EK124	22
MRE1112ET462	12	MRE1711EG003	33	MRE5021EC505	19	MRE5334EY659	22
MRE1112ET972	12	MRE1711ER208	33	MRE5021ET134	19	MRE9011EJ148	8
MRE1121ED386	12	MRE1711ES209	33	MRE5021EU135	18	MRE9011EN602	8
MRE1121EY759	12	MRE1811E8603	33	MRE5021EZ758	19	MRE9012EJ147	8
MRE1122E8379	12	MRE1821E9506	34	MRE5022E9500	19	MRE9012EP601	8
MRE1122EU753	12	MRE1821EQ268	34	MRE5022EP746	18	MRE9131EU112	13
MRE1124EJ931	13	MRE1831E3596	34	MRE5022EQ747	18	MRE9131EW114	13
MRE1124EJ932	13	MRE1911E0391	36	MRE5022ET132	19	MRE9132E5581	13

* C.N.I.T. = Code National d'Identification du Type (code D2.1 sur nouvelles cartes grises)

Type Mines OU C.N.I.T.*	Encadré N°	Type Mines OU C.N.I.T.*	Encadré N°	Type Mines OU C.N.I.T.*	Encadré N°	Type Mines OU C.N.I.T.*	Encadré N°
MRE9132ER107	13	J11405	46	JKOT	48	MRE3716H4299	41
MRE9132ET109	13	J11505	46	JKOU	38	MRE3716H5300	41
MREZ001E2043	8	J11605	43	JKOY	53	MRE3716H6301	41
MREZ002EY037	8	J11608	43	JKOYAC	53	MRE3716H7302	41
S57104	6	J11705	49	JKOYCC	53	MRE3716HH869	41
S57105	6	J11708	49	JK1D	41	MRE3716HJ871	41
S57205	7	J63305	47	JKAFAB	55	MRE3716HW873	41
S576	30	J63325	47	JKAFCB	55	MRE3716HY875	41
S57605	30	J63405	47	M10RENV000J651	55	MRE3716HZ269	41
S576B5	30	J63505	47	M10RENV000K653	55	MRE3726H0233	41
S57A05	7	J63525	47	M10RENV000P683	40	MRE3726H2235	41
S57I05	30	J63555	47	M10RENV000R685	41	MRE3726H8762	41
S57IB5	30	J63605	43	M10RENV000S686	41	MRE3726H9763	41
S57L	30	J63615	43	M10RENV000T687	41	MRE3726HA764	41
S57L05	30	J63705	49	M10RENV000U688	41	MRE3726HB765	41
S57R05	7	J63708	49	M10RENV000V689	41	MRE3726HW229	41
SB07	20	J63712	49	M10RENV000W690	41	MRE3726HY231	41
SB07CF	20	J63805	52	M10RENV000X691	41	MRE3806HF495	54
SB08	18	J63845	52	M10RENV000Y692	41	MRE3806HG496	54
SB09	20	J63D05	47	MRE000AH0658	44	MRE3916H8308	55
SB090F	20	J63E05	46	MRE000AH3661	44	MRE3916H9309	55
SB0A	8	J63G05	49	MRE000AHR516	44	MRE3916HA310	55
SB0A0F	8	J63J22	52	MRE001AHB499	44	MRE3926H0238	55
SB0E	31	JE0A02	44	MRE001AHE502	44	MRE3926H1239	55
SB0EOE	31	JE0A05	44	MRE001AHG504	44	MRE3926H2240	55
SB0EOF	31	JE0A15	44	MRE001AHH505	50	MRE3926H3047	55
SB0F	8	JE0G02	54	MRE001AHJ118	43	MRE3926H3241	55
SB0H	23	JE0GL2	54	MRE001AHK508	54	MRE3926H4048	55
SB0J	31	JE0H05	50	MRE001AHL121	44	MRE5306NK502	39
SBOR0F	31	JE0HL5	50	MRE001AHL509	54	MRE5406HE492	50
SB10	8	JE0K05	48	MRE001AHN123	44	MRE5406HG494	50
SB1K	8	JE0KL5	48	MRE001AHP124	50	MRE5406HM863	48
SB2J	18	JE0L02	40	MRE001AHP125	50	MRE5406HP503	50
SB3A	18	JE0L05	40	MRE1406HY488	44	MRE5406HP865	48
SB3A0F	8	JE0LL5	40	MRE1406HZ489	44	MRE5406HQ504	50
SB3KEF	8	JE0M05	39	MRE1406NF499	44	MRE5416HG202	38
SB3M	18	JE0N05	40	MRE1606HA807	40	MRE5416HH275	38
SB8M05	18	JE0NL5	40	MRE1606HB614	40	MRE5416HJ276	38
SBR7EF	20	JE0P05	50	MRE1606HB808	40	MRE5416HL279	38
SBR8EF	18	JE0PL5	50	MRE1606HC615	40	MRE5416HM280	38
SBR9EF	20	JE0S05	48	MRE1616HJ038	40	MRE5426HM279	38
SROA	17	JE0SL5	48	MRE1616HJ039	40	MRE5426HN280	38
SROF	19	JK00	55	MRE1716H9188	45	MRE5506HV862	48
SROG	19	JK00AB	55	MRE1716H9285	45	MRE5506HX864	48
SROH	19	JK00CB	55	MRE1716HA189	45	MRE5616H2204	48
SROJ	12	JK07	51	MRE1716HA286	45	MRE5616H3205	48
SROS	12	JK07AB	51	MRE1716HA868	41	MRE5616H4206	48
SR1FOH	19	JK07CB	51	MRE1716HB190	45	MRE5616H5207	48
SR1G0H	19	JK08	41	MRE1716HB287	45	MRE5616H7281	48
SR1J0H	12	JK09	40	MRE1716HC191	45	MRE5616H8282	48
SR1U	13	JK09A6	40	MRE1716HC288	45	MRE5616H9283	48
URE5012EJ996	19	JK09B6	40	MRE1716HC870	41	MRE5616H9793	48
URE5021E7572	19	JK0A	41	MRE1716HE872	41	MRE5616HA284	48
URE5022EU133	19	JK0AA6	41	MRE1716HF219	45	MRE5616HA794	48
URE5211EK979	19	JK0AAB	41	MRE1716HH221	45	MRE5616HJ512	48
URE5212ED970	19	JK0AB6	41	MRE1716HP265	45	MRE5616HK513	48
URE5221EQ571	19	JK0ABB	41	MRE1716HQ266	45	MRE5616HM515	48
URE5311E0985	19	JK0AC6	41	MRE1716HR267	45	MRE5626HB212	48
VRE000AEG790	8	JK0AD6	41	MRE1716HR874	41	MRE5626HC213	48
VRE000AEJ792	8	JK0ADB	41	MRE1716HS268	45	MRE5626HD214	48
VRE000AEJ793	8	JK0B	45	MRE1726H0882	41	MRE5626HE215	48
VRE001AEE338	8	JK0D	45	MRE1726H1883	41	MRE7616HA303	48
VRE1001EP002	6	JK0F	55	MRE1726H2884	41	MRE7616HB304	48
VRE1001ET042	8	JK0G	38	MRE1726H3885	41	MRE7616HC305	48
VRE1001EU043	8	JK0H	48	MRE1726HP228	41	MRE7616HD306	48
VRE5001E4005	30	JK0HA6	48	MRE1726HR230	41	MRE7616HN607	48
VRE5001E9046	30	JK0HAB	48	MRE1726HT232	41	MRE7616HP608	48
VRE5001EA047	30	JK0HC6	48	MRE1726HV234	41	MRE7616HP609	48
VRE5001EB727	30	JK0HCB	48	MRE3406H3487	44	MRE7616HQ610	48
VRE5001ED729	30	JK0J	53	MRE3606HJ809	40	MRE7626HJ250	51
VRE5001EJ698	30	JK0K	40	MRE3606HJ810	40	MRE7626HK251	51
VRE5001EK700	30	JK0L	40	MRE3616HQ040	40	MRE7626HL216	48
		JK0N	41	MRE3716H0270	41	MRE7626HL252	51
		JK0P	55	MRE3716H1271	41	MRE7626HM217	48
		JK0S	55	MRE3716H2272	41	MRE7626HM253	51
Espace							
J11205	42						

* C.N.I.T. = Code National d'Identification du Type (code D2.1 sur nouvelles cartes grises)

Type Mines OU C.N.I.T.*	Encadré N°	Type Mines OU C.N.I.T.*	Encadré N°	Type Mines OU C.N.I.T.*	Encadré N°	Type Mines OU C.N.I.T.*	Encadré N°
MRE7626HN218	48	JMG4NA	79	MRE5526AM822	79	FC4AAF	83
MRE7626HP219	48	JMG5D6	79	MRE5536AN143	79	FC5SAF	90
MRE7716H0804	53	JMG6D6	76	MRE5536AP144	79	FCASA8	89
MRE7716H1223	53	JMG6N6	76	MRE5536AS148	79	FCAVA8	91
MRE7716H2224	53	JMGED6	76	MRE5626A5770	80	FW0B	88
MRE7716H3225	53	JMGEN6	76	MRE5626A6771	80	FW0BB5	88
MRE7716H4226	53	JMGKD6	80	MRE5626A7772	80	FW0BC5	88
MRE7716H8291	53	JMGKDB	80	MRE5626AJ165	80	FW0BK5	88
MRE7716H9292	53	JMGKN6	80	MRE5626AL423	80	FW0C	88
MRE7716HV289	53	JMGKNB	80	MRE5626AR429	80	FW0CB6	88
MRE7716HV835	53	JMJ4N6	79	MRE7526AE517	79	FW0CK6	88
MRE7716HW290	53	JMJ4NA	79	MRE7526AM525	79	FW0F	88
MRE7716HZ803	53	JMJ6N6	76	MRE7526AR530	79	FW0FB6	88
MRE7726HQ247	53	JMJEN6	76	MRE7626A3532	80	FW0FC6	88
MRE7726HR248	53	JMJKN6	80	MRE7626AU523	80	FW0FK6	88
S11205	42	JMJKNB	80	MRE7626AZ528	80	FW0G	88
S11205T	42	JMJRN6	77	URE5626A0086	80	FW0GB5	88
S11505	46	JMK4D6	79	URE7526AR530	79	FW0GC5	88
S63505	47	JMPKD6	80			FW0GF5	88
S63525	47	JMS406	79	Kangoo		FW1BE5	88
S63535	47	JMT4N6	79	FC00	89	FW1BF5	88
S63705	49	MRE1416A1594	77	FC01	83	FW1BH5	88
S63D05	47	MRE1416AS621	77	FC05	84	FW1BM5	88
		MRE1416AY397	77	FC07	86	KC00	89
Fuego		MRE1426AA056	77	FC07AF	86	KC01	83
136004	70	MRE1426AC058	77	FC07BF	86	KC05	84
136005	70	MRE1426AJ513	77	FC08	86	KC07	86
136204	71	MRE1426AK454	77	FC09	86	KC08	86
136205	71	MRE1426AM129	77	FC09AF	86	KC08EF	86
136300	73	MRE1426AN130	77	FC0A	83	KC08GF	86
136500	72	MRE1426AY529	77	FC0AAF	83	KC09	86
136600	74	MRE1436A5377	77	FC0B	85	KC0A	83
136B00	73	MRE1516AB400	81	FC0BAA	85	KC0AAF	83
R136004	70	MRE1516AC401	81	FC0BAF	85	KC0AAG	83
R136005	70	MRE1516AC595	81	FC0C	85	KC0B	85
R1362	71	MRE1516AD596	81	FC0CAF	85	KC0BEF	85
R136204	71	MRE1526AQ511	81	FC0D	92	KC0CAF	85
R136205	71	MRE1526AV516	81	FC0DAF	92	KC0CBF	85
R1363	73	MRE1716AP623	82	FC0EAF	92	KC0DAF	92
R136301	73	MRE1726AD417	82	FC0E	92	KC0EAF	92
R136500	72	MRE3516AL598	81	FC0EAF	92	KC0EAG	92
R136A	72	MRE3526AY416	81	FC0EBF	92	KC0EBF	92
		MRE5316A0591	75	FC0F	83	KC0F	83
		MRE5316AV913	76	FC0HBF	85	KC0H01	85
JM02D5	75	MRE5326A1591	75	FC0J	92	KC0HAF	85
JM0CDH	77	MRE5326A4594	76	FC0JAF	92	KC0HGF	85
JM0G	78	MRE5326A5595	76	FC0L	89	KC0J	92
JM0GD6	78	MRE5326A6596	75	FC0M	85	KC0JAF	92
JM0L	79	MRE5326AG581	76	FC0N	92	KC0JAG	92
JM0U	81	MRE5326AN940	76	FC0P	89	KC0JCF	92
JM0UD6	81	MRE5326AQ810	76	FC0PA8	89	KC0JEF	92
JM0UDA	81	MRE5326AQ943	76	FC0S	89	KC0K	83
JM0UN6	81	MRE5326AS521	76	FC0SA8	89	KC0L	89
JM0UNA	81	MRE5326AS582	76	FC0T	84	KC0M	85
JM0W	82	MRE5326AV815	76	FC0U	91	KC0MCF	85
JM0WN6	82	MRE5326AW428	76	FC0V	91	KC0N	92
JM14	79	MRE5326AY527	76	FC0VA8	91	KC0P	89
JM15	79	MRE5336A1141	76	FC0W	84	KC0PA8	89
JM16	76	MRE5336A2142	76	FC1D	84	KC0PAF	89
JM17	79	MRE5336A7147	75	FC1DAF	84	KC0S	89
JM1D	79	MRE5336AY138	76	FC1DBF	84	KC0SA8	89
JM1E	76	MRE5416AC593	78	FC1DGF	84	KC0SAF	89
JM1K	80	MRE5416AJ344	78	FC1E	87	KC0T	84
JM1R	77	MRE5421AU171	79	FC1EAF	87	KC0U	91
JM1R06	77	MRE5426A4426	79	FC1EBF	87	KC0V	91
JM1R0A	77	MRE5426AX164	79	FC1ECF	87	KC0VA8	91
JM1RD6	77	MRE5426AZ166	79	FC1EHF	87	KC0VAF	91
JM1RN6	77	MRE5516AE876	79	FC1F	86	KC0W	84
JM1U	81	MRE5516AG878	79	FC1FAF	86	KC0WGF	84
JMAUN6	81	MRE5526A0678	79	FC1G	87	KC1	90
JMAUNA	81	MRE5526AC424	79	FC1GAF	87	KC1D	84
JMAWN6	82	MRE5526AC679	79	FC1GBF	87	KC1E	87
JMG4D6	79	MRE5526AF682	79	FC1N	89	KC1EGF	87
JMG4DA	79	MRE5526AG816	79	FC1R	86	KC1F	87
JMG4N6	79	MRE5526AK820	79	FC1S	86	KC1G	87

* C.N.I.T. = Code National d'Identification du Type (code D2.1 sur nouvelles cartes grises)

Type Mines OU C.N.I.T.*	Encadré N°	Type Mines OU C.N.I.T.*	Encadré N°	Type Mines OU C.N.I.T.*	Encadré N°	Type Mines OU C.N.I.T.*	Encadré N°
KC1N	89	MRE2212KN692	89	VRE5002KM403	92	BG0A	94
KC1R	86	MRE2212KX059	89	VRE5002KP405	92	BG0A05	94
KC1S	86	MRE3212KC132	89			BG0A0A	94
KC4AAF	83	MRE3212KM688	89	Laguna		BG0B	97
KCAPA8	89	MRE5002K6396	92	OB	119	BG0B05	98
KCAVA8	91	MRE5002K6723	92	556A	108	BG0C	98
KCAVAK	91	MRE5002K7397	92	A56A	108	BG0C05	97
KCE8EF	86	MRE5002K8725	92	B560	96	BG0D	119
KCEDEF	84	MRE5002KA957	86	B5600C	96	BG0DOB	119
KCR7EF	86	MRE5002KA982	92	B5600F	96	BG0E	99
KCR8EF	86	MRE5002KB958	86	B560PF	96	BG0E05	99
KCTEEF	87	MRE5002KB983	92	B56105	94	BG0E0A	99
KCTGEF	87	MRE5002KD403	92	B56205	114	BG0F	115
KW0B	88	MRE5002KE404	92	B56305	97	BG0F06	115
KW0BB5	88	MRE5002KF405	92	B56405	97	BG0F0B	115
KW0BD5	88	MRE5002KF987	86	B5640C	97	BG0G	99
KW0C	88	MRE5002KG406	92	B5660E	114	BG0G06	99
KW0CB6	88	MRE5002KY848	92	B56805C	94	BG0J	97
KW0CD6	88	MRE5004K4390	92	B56905	117	BG0J0A	97
KW0F	88	MRE5004K5391	92	B569LE	117	BG0K	108
KW0FB6	88	MRE5012K0619	86	B56AK5	96	BG0K05	108
KW0FD6	88	MRE5012K2657	86	B56B05	96	BG0K0A	108
KW0G	88	MRE5012K5563	86	B56BJC	96	BG0L	94
KW0GB5	88	MRE5012K6564	86	B56BK5	96	BG0L05	94
KW2C	88	MRE5012KB109	86	B56C02	105	BG0M	97
KW2CG6	88	MRE5012KC570	86	B56C05	105	BG0M0A	97
KW2F	88	MRE5012KD111	86	B56C0C	105	BG0N	112
KW2FG6	88	MRE5012KE112	92	B56CD2	105	BG0N05	112
MRE000APN964	83	MRE5012KX616	86	B56CD5	105	BG0NOA	112
MRE000APP965	85	MRE5022KJ018	87	B56CDD	105	BG0P	108
MRE000APQ967	92	MRE5022KJ019	86	B56CK2	105	BG0R	99
MRE000APR968	92	MRE5022KN023	86	B56CK5	105	BG0R06	99
MRE001APK112	83	MRE5022KT029	87	B56CKC	105	BG0S	113
MRE001APL113	85	MRE5022KV031	86	B56D05	111	BG0S06	113
MRE001APN115	92	MRE5032K4488	86	B56F05	114	BG0S0B	113
MRE001APN151	83	MRE5032K5489	86	B56F25	114	BG0T	110
MRE001APP116	92	MRE5032KM093	86	B56H02	105	BG0U	94
MRE001APP152	85	MRE5102KF916	91	B56HKC	105	BG0V	97
MRE001APQ154	92	MRE5112K9133	86	B56J02	102	BG0V05	97
MRE001APR155	92	MRE5112K9618	86	B56J05	102	BG0W	108
MRE001APT157	83	MRE5112KB135	86	B56L02	105	BG0Y	119
MRE001APV159	92	MRE5112KC136	86	B56L05	105	BG0Z	109
MRE1002K6638	83	MRE5112KE659	86	B56L0G	107	BG10	101
MRE1002K7639	83	MRE5112KJ567	86	B56L3G	107	BG12	101
MRE1002KR393	83	MRE5112KK568	86	B56LDA	105	BG15B6	99
MRE1002KX399	83	MRE5122KJ105	86	B56LDE	105	BG19B6	116
MRE1002KX981	83	MRE5122KQ113	86	B56M05	111	BG1A	99
MRE1002KY400	83	MRE5222K3116	87	B56MLE	111	BG1FB6	115
MRE1004KE387	83	MRE5222KR104	87	B56N02	105	BG1FBB	115
MRE1012KU686	83	MRE5222KT045	87	B56N05	105	BG1G	95
MRE1102K5627	85	MRE5222UL936	87	B56P05	114	BG1GB6	99
MRE1102K6628	85	MRE5232K2089	87	B56S05	96	BG1H	95
MRE1102K9401	85	MRE5232K4479	87	B56SJC	96	BG1K	119
MRE1102KA402	85	MRE5322UW937	88	B56SK5	96	BG1L	113
MRE1102KB985	85	MRE5332KD090	88	B56T05	96	BG1M	110
MRE1102KJ640	85	MRE5332KF092	88	B56U0G	107	BG1N	116
MRE1102KJ641	85	MRE5332KF480	88	B56V02	118	BG1P	113
MRE1102KR904	85	MRE5332KW486	88	B56V05	118	BG1PBA	108
MRE1102KS905	85	MRE6112K0060	91	B56VL2	118	BG1PBE	108
MRE1112K6663	85	MRE6212KQ489	91	B56VL5	118	BG1TB6	110
MRE1112K7664	84	MRE9012KM690	83	B56W05	99	BG1V	101
MRE1112KGO55	84	MRE9012KV153	83	B56Y05	97	BG1W	99
MRE1112KJ021	84	MRE9012KZ606	83	B56Y0C	97	BG1Y	109
MRE1112KJ022	84	MSM5304AY002	88	BG0	99	BG1ZB6	109
MRE1112KU130	84	URE5222K3116	87	BG00	108	BG1ZBB	109
MRE1112KU615	84	VRE000APW964	83	BG01	119	BG3L05	95
MRE1122K4078	84	VRE000APZ967	92	BG02	119	BG42B6	101
MRE1122K5079	84	VRE001AP0155	92	BG03	109	BG42BA	101
MRE1122K8082	84	VRE001APW151	83	BG04	97	BG4AB6	99
MRE1122KN025	84	VRE001APX116	92	BG0405	97	BG4HBE	95
MRE1212KF687	89	VRE001APX152	85	BG05	99	BG4KBB	119
MRE1212KH689	89	VRE001APZ154	92	BG06	97	BG4NBB	116
MRE1212KW025	89	VRE1002K6399	83	BG0606	97	BG4VB6	101
MRE1232K9485	90	VRE1102KE627	85	BG08	101	BG4VBA	101
MRE2212KM691	89	VRE1102KJ401	85	BG09	116	BG4WB6	99

* C.N.I.T. = Code National d'Identification du Type (code D2.1 sur nouvelles cartes grises)

Type Mines OU C.N.I.T.*	Encadré N°	Type Mines OU C.N.I.T.*	Encadré N°	Type Mines OU C.N.I.T.*	Encadré N°	Type Mines OU C.N.I.T.*	Encadré N°
BGCFB6	115	K56LGC	105	KG1FBB	115	MRE000ABC701	105
BGCFBB	115	K56M05	111	KG1G	95	MRE000ABD023	105
BGCCB6	99	K56MHE	111	KG1GB6	100	MRE000ABD217	105
BGCPBA	108	K56MJE	111	KG1H	95	MRE000ABD508	114
BGCPBE	108	K56N02	105	KG1K	119	MRE000ABD896	117
BGCTB6	110	K56N05	105	KG1L	110	MRE000ABE096	111
BGCZB6	109	K56S0C	96	KG1N	116	MRE000ABE157	96
BGCZBB	109	K56SG5	96	KG1V	101	MRE000ABE678	96
BGE2B6	101	K56TF5	96	KG1W	99	MRE000ABE703	105
BGEAB6	99	K56V02	118	KG1Y	109	MRE000ABE897	117
BGEHBE	95	K56V05	118	KG42B6	101	MRE000ABF025	105
BGEKBB	119	K56VJ2	118	KG42BA	101	MRE000ABF061	114
BGEVB6	101	K56VJ5	118	KG43B6	101	MRE000ABF158	96
BGEWB6	99	K56W05	99	KG4AB6	99	MRE000ABF510	114
BGRF06	115	K56WF5	99	KG4NBB	116	MRE000ABF704	105
BGRF0B	115	K56Y05	97	KG4VB6	101	MRE000ABG062	114
BGRG06	99	K56YF5	97	KG4WB6	99	MRE000ABG220	111
BGRR06	99	K56Z	96	KGCGB6	100	MRE000ABG511	114
BT00	93	KG0	99	KGE3B6	101	MRE000ABG705	105
BT05	103	KG00	108	KGEVB6	101	MRE000ABH512	117
BT06	104	KG01	119	KGRF0B	115	MRE000ABH900	118
BT0A	93	KG02	119	KGRG06	100	MRE000ABJ064	96
BT0A06	93	KG03	109	KT0A	93	MRE000ABJ065	96
BT0F	103	KG04	97	KT0A06	93	MRE000ABJ513	117
BT0F06	103	KG0405	97	KT0AE6	93	MRE000ABJ999	96
BT0H	104	KG05	99	KT1A06	93	MRE000ABK066	96
BT0W	103	KG06	98	M10RENV0008253	103	MRE000ABM226	117
BT0Y	104	KG08	101	M10RENV000A255	104	MRE000ABN033	114
BT1A06	93	KG09	116	M10RENV000B256	104	MRE000ABN227	117
BT1F06	103	KG0A	94	M10RENV000S298	103	MRE000ABN712	114
BT1H0E	104	KG0A05	94	M10RENV000T299	104	MRE000ABP035	96
BT1W0D	103	KG0A0A	94	M10RENV000W241	103	MRE000ABP714	114
BT1Y0E	104	KG0B	97	MRE000AB0470	114	MRE000ABQ036	96
BT1YDE	104	KG0C	97	MRE000AB0689	96	MRE000ABQ072	96
K560	96	KG0C05	97	MRE000AB1011	96	MRE000ABQ679	96
K5600C	96	KG0D	119	MRE000AB1471	96	MRE000ABR716	117
K560G5	96	KG0D0B	119	MRE000AB1859	96	MRE000ABS717	117
K560GC	96	KG0DOB	119	MRE000AB1884	105	MRE000ABU173	105
K560PF	96	KG0E	99	MRE000AB2472	96	MRE000ABY881	105
K56105	94	KG0E05	99	MRE000AB2885	105	MRE000ABZ469	114
K561F5	94	KG0F	115	MRE000AB3013	96	MRE000ABZ688	96
K56205	114	KG0F06	115	MRE000AB3049	105	MRE000AC0433	105
K56305	97	KG0G	100	MRE000AB3473	96	MRE000AC0857	118
K563F5	97	KG0G06	100	MRE000AB4183	114	MRE000AC1107	96
K56405	97	KG0J	97	MRE000AB4474	96	MRE000AC2435	114
K564F5	97	KG0J0A	97	MRE000AB4499	105	MRE000AC3109	96
K56605	114	KG0K	108	MRE000AB5051	105	MRE000AC3436	117
K566F5	114	KG0K05	108	MRE000AB5087	105	MRE000AC3727	96
K56805	94	KG0K0A	108	MRE000AB5184	114	MRE000AC4983	105
K568F5	94	KG0L	94	MRE000AB5500	105	MRE000AC5244	105
K56905	117	KG0L05	94	MRE000AB6185	96	MRE000AC6245	105
K5690E	117	KG0M	97	MRE000AB6501	105	MRE000AC6985	105
K569FE	117	KG0M0A	97	MRE000AB7089	105	MRE000AC7731	96
K569HE	117	KG0N	112	MRE000AB7186	96	MRE000AC7986	105
K569JE	117	KG0N05	112	MRE000AB7211	105	MRE000AC8987	105
K56C02	105	KG0NOA	112	MRE000AB7477	96	MRE000AC9248	105
K56C0C	105	KG0P	108	MRE000AB7502	105	MRE000AC9988	105
K56CGC	105	KG0R	99	MRE000AB7696	96	MRE000ACB117	105
K56CKC	105	KG0R06	99	MRE000AB8187	96	MRE000ACB250	114
K56CKE	105	KG0S	113	MRE000AB8478	96	MRE000ACC251	117
K56D05	111	KG0S06	113	MRE000AB8503	105	MRE000ACC991	111
K56F05	114	KG0S0B	113	MRE000AB9188	96	MRE000ACE993	114
K56FF5	114	KG0T	110	MRE000AB9213	105	MRE000ACF739	111
K56H01	105	KG0TB6	110	MRE000AB9443	96	MRE000ACF994	117
K56HG C	105	KG0U	94	MRE000AB9892	114	MRE000ACH741	114
K56J	102	KG0V	97	MRE000ABA092	105	MRE000ACH838	96
K56J02	102	KG0W	108	MRE000ABA214	105	MRE000ACH996	118
K56J05	102	KG0Y	119	MRE000ABA444	96	MRE000ACJ415	96
K56JF5	102	KG0Z	109	MRE000ABB021	105	MRE000ACJ742	117
K56L02	105	KG10	101	MRE000ABB215	105	MRE000ACJ997	118
K56L0A	105	KG12	101	MRE000ABB506	111	MRE000ACK744	111
K56L0C	105	KG13	101	MRE000ABB700	105	MRE000ACL745	111
K56L0G	105	KG15B6	99	MRE000ABB869	96	MRE000ACM419	96
K56L3G	105	KG1A	99	MRE000ABB894	114	MRE000ACM746	118
K56LFE	105	KG1FB6	115	MRE000ABC216	105	MRE000ACN420	96

* C.N.I.T. = Code National d'Identification du Type (code D2.1 sur nouvelles cartes grises)

Type Mines OU C.N.I.T.*	Encadré N°	Type Mines OU C.N.I.T.*	Encadré N°	Type Mines OU C.N.I.T.*	Encadré N°	Type Mines OU C.N.I.T.*	Encadré N°
MRE000ACN844	105	MRE001ACH219	105	MRE1404C3962	97	MRE3904CM878	119
MRE000ACP421	96	MRE001ACJ221	105	MRE1404C4963	97	MRE3912CV890	119
MRE000ACQ423	96	MRE001ACJ256	111	MRE1404C6965	97	MRE3912CZ894	119
MRE000ACS971	96	MRE001ACK222	105	MRE1404C8931	97	MRE3914C9900	119
MRE000ACU427	105	MRE001ACK258	114	MRE1404CP876	97	MRE3914CD904	119
MRE000ACV234	96	MRE001ACL223	105	MRE1404CQ877	97	MRE5202C4321	114
MRE000ACV852	111	MRE001ACL259	117	MRE1404CT880	97	MRE5202CW058	114
MRE000ACW429	105	MRE001ACL550	102	MRE1412C3117	97	MRE5204BR086	114
MRE000ACX103	96	MRE001ACM224	105	MRE1412C6932	94	MRE5212CN885	99
MRE000ACX854	114	MRE001ACN261	118	MRE1412CD939	94	MRE5214C1895	99
MRE000ACY855	117	MRE001ACN552	111	MRE1412CG069	97	MRE5302C0598	102
MRE000ACY977	96	MRE001ACP227	111	MRE1412CP174	97	MRE5302C3310	102
MRE001AB0009	96	MRE001ACP262	118	MRE1414C8118	97	MRE5302C5966	99
MRE001AB2435	114	MRE001ACP263	102	MRE1414CL070	97	MRE5302C7932	99
MRE001AB4304	114	MRE001ACP553	117	MRE1414CP946	94	MRE5302CJ325	102
MRE001AB4437	114	MRE001ACR229	114	MRE1512C1856	108	MRE5302CP719	102
MRE001AB5183	105	MRE001ACR265	111	MRE1512C5145	108	MRE5302CQ757	102
MRE001AB5402	96	MRE001ACR556	105	MRE1512CC928	108	MRE5302CV823	99
MRE001AB6281	96	MRE001ACS230	117	MRE1512CJ935	108	MRE5304B1280	102
MRE001AB6306	114	MRE001ACS266	117	MRE1512CY853	108	MRE5304B2281	102
MRE001AB6439	117	MRE001ACS363	96	MRE1514C1949	108	MRE5304BM714	102
MRE001AB7016	96	MRE001ACT267	118	MRE1514CA146	108	MRE5304BN715	102
MRE001AB8308	117	MRE001ACT558	105	MRE1514CU942	108	MRE5304BQ754	102
MRE001AB9187	105	MRE001ACU232	118	MRE1602C3971	108	MRE5304BR755	102
MRE001AB9309	117	MRE001ACU390	102	MRE1602C8721	111	MRE5304BU589	102
MRE001ABC021	105	MRE001ACV233	118	MRE1602CA335	111	MRE5304BW821	99
MRE001ABC445	102	MRE001ACV269	94	MRE1602CC337	111	MRE5312CA546	99
MRE001ABD446	102	MRE001ACW234	102	MRE1602CH306	111	MRE5312CC548	99
MRE001ABE314	102	MRE001ACW392	111	MRE1602CK600	111	MRE5312CK071	99
MRE001ABE447	117	MRE001ACX393	117	MRE1604B7717	108	MRE5314CF547	99
MRE001ABF024	105	MRE001ACY236	96	MRE1604C8972	108	MRE5402CA961	99
MRE001ABF315	102	MRE001ACY394	118	MRE1622C9950	103	MRE5402CD601	117
MRE001ABF412	96	MRE001ACZ395	118	MRE1622CC978	103	MRE5402CF348	117
MRE001ABF448	117	MRE1202CE052	96	MRE1622CJ959	103	MRE5402CG349	117
MRE001ABG025	105	MRE1202CF053	96	MRE1622U0826	103	MRE5402CH059	117
MRE001ABG316	117	MRE1202CH055	96	MRE1622U5831	103	MRE5402CL354	117
MRE001ABJ161	96	MRE1202CL314	96	MRE1632CP310	103	MRE5402CQ323	117
MRE001ABJ610	102	MRE1202CN316	96	MRE1712C3317	113	MRE5402CR324	117
MRE001ABK611	102	MRE1202CP318	96	MRE1712CS888	113	MRE5402CU873	99
MRE001ABL454	94	MRE1204B8079	96	MRE1712CW892	113	MRE5404B0294	117
MRE001ABL612	117	MRE1204BD084	96	MRE1714C8318	113	MRE5404B2296	117
MRE001ABM455	94	MRE1302C1611	94	MRE1802C2343	118	MRE5404B3297	117
MRE001ABM613	117	MRE1302C3322	94	MRE1802C3308	118	MRE5404B5590	117
MRE001ABN032	114	MRE1302C6907	94	MRE1802C4345	118	MRE5404BF090	117
MRE001ABN323	94	MRE1302CT869	94	MRE1802C6602	118	MRE5404BG285	117
MRE001ABP034	114	MRE1302CU604	94	MRE1812C1959	109	MRE5404C4879	100
MRE001ABR036	117	MRE1304BL592	94	MRE1814C8962	110	MRE5404CH964	100
MRE001ABR194	114	MRE1304BP596	94	MRE3402C5599	105	MRE5412C1854	99
MRE001ABS037	117	MRE1304BQ597	94	MRE3402CB968	97	MRE5412C2855	99
MRE001ABS619	94	MRE1304BR282	94	MRE3402CD607	105	MRE5412C4857	99
MRE001ABT171	96	MRE1304BS283	94	MRE3402CQ329	105	MRE5412C8667	99
MRE001ABT196	114	MRE1304CB908	94	MRE3404BB286	105	MRE5412CF929	99
MRE001ABT293	105	MRE1304CC970	94	MRE3404CG969	97	MRE5412CH391	99
MRE001ABT620	94	MRE1304CE875	94	MRE3512CH927	108	MRE5412CW231	99
MRE001ABV198	117	MRE1402C0636	97	MRE3512CP122	108	MRE5412CY851	99
MRE001ABV428	105	MRE1402C3930	97	MRE3512CP934	108	MRE5414C1232	100
MRE001ABW199	117	MRE1402C4870	97	MRE3514CT123	108	MRE5414C6952	99
MRE001ABW271	96	MRE1402C5350	105	MRE3514CZ941	112	MRE5414CC861	100
MRE001ABX297	105	MRE1402C5799	97	MRE3712C3893	109	MRE5414CE669	100
MRE001ABY007	96	MRE1402C5871	97	MRE3712C8449	113	MRE5414CF864	99
MRE001AC0396	94	MRE1402C6606	105	MRE3712CZ889	109	MRE5414CG865	100
MRE001AC2398	105	MRE1402C6642	97	MRE3714CD450	113	MRE5414CJ867	99
MRE001AC4242	96	MRE1402C7352	97	MRE3714CD899	113	MRE5414CZ945	99
MRE001AC4375	105	MRE1402C7643	97	MRE3714CH903	113	MRE5422C7956	93
MRE001AC5207	96	MRE1402CA610	97	MRE3722C0961	104	MRE5422CH190	99
MRE001AC8379	105	MRE1402CB065	105	MRE3722UM832	104	MRE5422CK193	99
MRE001ACA248	105	MRE1402CJ874	97	MRE3722UW842	104	MRE5422CY196	99
MRE001ACB213	96	MRE1402CN332	105	MRE3732C5153	104	MRE5422CZ948	93
MRE001ACC250	105	MRE1402CP333	105	MRE3732CK168	104	MRE5422UR825	93
MRE001ACC383	111	MRE1404B0633	97	MRE3802C7342	118	MRE5422UW830	93
MRE001ACD251	105	MRE1404B1634	97	MRE3802C9344	118	MRE5424C5199	100
MRE001ACE252	105	MRE1404BU300	105	MRE3802CA309	118	MRE5424C8202	100
MRE001ACE385	114	MRE1404BV301	97	MRE3802CD603	118	MRE5424CR997	93
MRE001ACF253	105	MRE1404BW302	97	MRE3804BJ289	118	MRE5424UJ849	93
MRE001ACF386	117	MRE1404BY595	97	MRE3902C1872	119	MRE5424UP854	93

* C.N.I.T. = Code National d'Identification du Type (code D2.1 sur nouvelles cartes grises)

Type Mines OU C.N.I.T.*	Encadré N°	Type Mines OU C.N.I.T.*	Encadré N°	Type Mines OU C.N.I.T.*	Encadré N°	Type Mines OU C.N.I.T.*	Encadré N°
MRE5432C7470	93	FC30A1	123	MRE5113MP726	121	RJ22	123
MRE5432C8471	93	FC30A2	123	MRE5203M5989	126	RJ25	129
MRE5432CX072	93	FD0C	132	MRE5203M6990	126	RJ26	129
MRE5434C2073	93	FD0G	126	MRE5203ME840	126	RJ2E	125
MRE5434CH476	93	FD0L	122	MRE5213M1729	126	RJ2G	129
MRE5434CJ477	93	FD0M	128	MRE5213M4732	126	RJ2H	131
MRE5512C0940	99	FD0N	126	MRE5213M8736	126	RJ2J	131
MRE5512CQ930	99	FD0P	121	MRE5213MC413	126	RJ52	123
MRE5512CT933	99	FD0U	128	MRE5213MD414	126	RJ55	129
MRE5514C8944	99	FD0V	128	MRE5213MG417	126	RJ56	129
MRE5514CB947	99	FD1M	128	MRE5213MP426	126	RJ5E	125
MRE5514CF951	99	FD1N	126	MRE5213MR428	126	RJ5G	129
MRE5514CJ954	99	FD2G	126	MRE5213MU431	126	RJ5H	131
MRE5522C6194	99	FD3G	126	MRE5213MV432	126	RJ5J	131
MRE5522CA198	99	FDAKD5	121	MRE5213MW724	126	RJ92	123
MRE5612CA552	115	FDAPD5	121	MRE5213MX725	126	RL92	123
MRE5612CF848	115	FDAUD6	128	MRE5413M8425	128	UD0C	132
MRE5612CG849	115	FDAVD5	128	MRE5413MA427	128	UD0G	126
MRE5614C1090	115	FDBEH5	128	MRE5413MD430	128	UD0V	128
MRE5614C1212	115	FDBUD6	128	MRE5413MH434	128	UD1G	126
MRE5614C6605	116	FDBUH6	128	MRE5413MJ727	128	UDCCG5	132
MRE5614CF553	115	FDBVD5	128	MRE5413MK013	128	UDCUG6	128
MRE5614CT858	116	FDBVH5	128	MRE5413MK728	128	UDCUK6	128
MRE5614CU859	115	FDCCH5	132	MRE5413MM730	128	UDCVG5	128
MRE7302CV720	102	FDCCCL5	132	MRE5413MQ734	128	UDCVK5	128
MRE7522C1122	101	FDCUD6	128	MRE5413MR735	128	VRE5103MH517	129
MRE7522CY119	101	FDCUE6	128	MRE5413MT737	128		
MRE7612C8253	115	FDCUH6	128	MRE5413MU411	128	Megane	
MRE7612CJ554	115	FDCUJ6	128	MRE5413MV412	128	BA00	147
MRE7612CN850	115	FDCUL6	128	MRE5413MZ416	128	BA04	147
MRE7614C1860	115	FDCUM6	128			BA0402	147
MRE7614CN555	115	FDCVD5	128	QH72	123	BA0405	147
MRE9312C6178	95	FDCVE5	128	QH74	130	BA05	152
MRE9314CN252	95	FDCVH5	128	QH92	123	BA07	162
MREZ304BF596	95	FDCVJ5	128	QH94	130	BA08	155
S56605	114	FDCVM5	128	QHA4	130	BA09	154
S56F05	114	HD0C	132	QJ72	123	BA0905	154
S56J05	102	HD0G	126	QJ74	130	BA0A	151
		HD0U	128	QJ92	123	BA0A05	151
		HD0V	128	QJ94	130	BA0B	147
		HD1G	126	R8D2	123	BA0B	136
		HDCUG6	128	R8D5	129	BA0E	137
		HDCUK6	128	R8D6	129	BA0E05	137
		HDCVG5	128	R8DE	125	BA0F	149
		HDCVK5	128	R8DG	129	BA0F02	149
		JD0B	132	RC92	123	BA0F05	149
		JD0G	126	RD8H	131	BA0F0F	149
		JD0L	122	RD8J	131	BA0G	162
		JD0M	128	RF12	123	BA0G02	162
		JD0N	126	RF13	124	BA0G05	162
		JD0P	121	RF1E	125	BA0G0C	162
		JD1G	126	RF1G	129	BA0GLA	162
		JD1L	122	RH12	123	BA0GLC	162
		JDAMD6	128	RH15	129	BA0H	159
		JDAMH6	128	RH16	129	BA0H05	159
		JDAND5	126	RH1E	125	BA0K	154
		JDANH5	126	RH1G	129	BA0K05	154
		JDAPD5	121	RH1H	131	BA0L	149
		JDCMH6	128	RH1J	131	BA0L05	149
		JDCNH5	126	RH2E	125	BA0N	155
		JDEMD6	128	RH2G	129	BA0N05	155
		JDEMH6	128	RH2H	131	BA0NM2	155
		JDEND5	126	RH52	123	BA0NM5	155
		JDENH5	126	RH55	129	BA0R	151
		JDEPD5	121	RH56	129	BA0R05	151
		JDGMH6	128	RH5E	125	BA0S	149
		JDGNH5	126	RH5G	129	BA0T	137
		JDKMD6	128	RH5H	131	BA0T05	137
		JDKND5	126	RH92	123	BA0U	151
		JDNJD5	126	RJ12	123	BA0U05	151
		JDNM	128	RJ15	129	BA0V	137
		JDNMD6	128	RJ16	129	BA0VM5	137
		JDNN	126	RJ1E	125	BA0W	136
		MRE5113M4415	121	RJ1G	129	BA0W05	136
		MRE5113MM433	121	RJ1H	131	BA0Y	154
				RJ1J	131		

* C.N.I.T. = Code National d'Identification du Type (code D2.1 sur nouvelles cartes grises)

Type Mines OU C.N.I.T.*	Encadré N°	Type Mines OU C.N.I.T.*	Encadré N°	Type Mines OU C.N.I.T.*	Encadré N°	Type Mines OU C.N.I.T.*	Encadré N°
BAOY05	154	CM05	157	EA0B	147	JA0F	149
BA10	136	CM080H	136	EA0B02	147	JA0F02	149
BA11	147	CM0B	136	EA0B05	147	JA0F05	149
BA12	150	CM0B0H	136	EA0C	157	JA0G	162
BA1A	150	CM0C	148	EA0D	136	JA0G02	162
BA1D	159	CM0C0H	148	EA0D05	136	JA0G05	162
BA1F	152	CM0F	139	EA0F	149	JA0G0A	162
BA1H	136	CM0G	152	EA0F0G	149	JA0J	151
BA1J	147	CM0H	136	EA0G	162	JA0J05	151
BA1K	147	CM0J	148	EA0G0A	162	JA0K	154
BA1M	150	CM0L	153	EA0G0C	162	JA0K05	154
BA1R	150	CM0U	157	EA0H	159	JA0L	149
BA1U	155	CM0W	161	EA0H05	159	JA0L05	149
BM00	152	CM14	153	EA0P	160	JA0N	155
BM02	140	CM16	145	EA0P05	160	JA0N05	155
BM05	157	CM17	153	EA0W	136	JA0Y	154
BM08	136	CM1B	148	EA0W05	136	JA0Y05	154
BM080H	136	CM1C	152	EA11	147	KA01	152
BM0B	136	CM1D	153	EA13	157	KA04	147
BM0B0H	136	CM1E	145	EA1H	136	KA0402	147
BM0C	148	CM1F	144	EA1J	147	KA0405	147
BM0COA	148	CM1G	152	EA1S	157	KA05	152
BM0COH	148	CM1K	156	EM05	157	KA0505	152
BM0F	139	CM1M	157	EM0C	148	KA0B	147
BM0F05	139	CM1N	157	EM0C0H	148	KA0D	136
BM0G	152	CM1R	146	EM0G	152	KA0F	149
BM0H	136	CM1R0A	146	EM0J	148	KA0J	151
BM0J	148	CM1R0H	146	EM0J0A	148	KA0J05	151
BM0J0H	148	CM1S	136	EM0JH	148	KA0N	155
BM0L	153	CM1S0H	136	EM0U	157	KA0N02	155
BM0M	163	CM1U	157	EM0U06	157	KA0N05	155
BM0M06	163	CMK406	153	EM0U0A	157	KA0R	151
BM0T	139	CMR205	140	EM0W	161	KA0V	138
BM0U	157	CMR20A	140	EM0W0C	161	KA0V05	138
BM0U06	157	CMS406	153	EM14	153	KA0W	136
BM0U0A	157	CMS40A	153	EM17	153	KA0W05	136
BM0W	161	CMSD06	153	EM1B	148	KA10	136
BM0W06	161	CMSE06	145	EM1C	152	KA11	147
BM11	163	CMSF05	144	EM1D	153	KA12	150
BM13	144	CMSK06	156	EM1E	145	KA1A	150
BM14	153	DA03	160	EM1G	152	KA1H	136
BM16	145	DA0305	162	EM1K	156	KA1J	147
BM17	153	DA04	147	EM1M	157	KA1R	150
BM1A	136	DA0402	147	EM1N	157	KA1U	155
BM1B	148	DA0405	147	EM1N06	157	KM00	152
BM1C	152	DA05	152	EM1R	146	KM02	143
BM1D	153	DA0B	147	EM1R0A	146	KM05	157
BM1E	145	DA0C	158	EM1R0H	146	KM0B	136
BM1F	144	DA0D	136	EM1T	161	KM0B0H	136
BM1G	152	DA0F	149	EM1U	157	KM0C	146
BM1K	156	DA0F02	149	EMK406	153	KM0C0H	148
BM1M	157	DA0F0G	149	EMK40A	153	KM0F	142
BM1N	157	DA0G	162	EMKD06	153	KM0G	152
BM1N06	157	DA0G02	162	EMPK06	156	KM0H	136
BM1R	146	DA0G05	162	EMRG06	152	KM0J	148
BM1R0A	146	DA0G0A	162	EMS406	153	KM0J0A	148
BM1R0H	146	DA0G0C	162	EMS40A	153	KM0L	153
BM1S	136	DA0H	159	EMSD06	153	KM0T	142
BM1S0H	136	DA0H05	159	EMSD0A	153	KM0U	157
BM1T	161	DA0N	155	EMSE06	145	KM0U06	157
BM1U	157	DA0N05	155	EMSK06	156	KM0U0A	157
BM1U06	157	DA0NM5	155	FA0J	151	KM0Y	148
BM1V	163	DA0P	160	FA0J05	151	KM13	143
BMK406	153	DA0W	136	FA0N	155	KM14	153
BMMJ0A	148	DA0W05	136	FA0Y	154	KM16	145
BMR205	144	DA10	136	FA0Y05	154	KM17	153
BMR20A	140	DA11	147	GM02	140	KM1B	148
BMRG06	152	DA13	158	GMOF	144	KM1C	152
BMS406	153	DA1H	136	GM1E	145	KM1D	153
BMS40A	153	DA1J	147	GM1F	144	KM1E	144
BMSD06	153	DA1S	158	JA0202	162	KM1F	144
BMSEA6	145	EA03	160	JA020C	162	KM1G	152
BMSF05	144	EA0305	160	JA0E	138	KM1K	156
CM00	152	EA04	147	JA0E05	138	KM1M	157
CM02	140	EA0402	147	JA0E5	138	KM1M06	157

* C.N.I.T. = Code National d'Identification du Type (code D2.1 sur nouvelles cartes grises)

Type Mines OU C.N.I.T.*	Encadré N°	Type Mines OU C.N.I.T.*	Encadré N°	Type Mines OU C.N.I.T.*	Encadré N°	Type Mines OU C.N.I.T.*	Encadré N°
KM1N	157	LM0J0H	148	MRE000AAJ357	149	MRE000AKK639	162
KM1R	146	LM0L	153	MRE000AAJ550	137	MRE000AKL931	151
KM1ROA	146	LM0T	141	MRE000AAJ902	137	MRE000AKM641	151
KM1ROH	146	LM0U	157	MRE000AAK128	137	MRE000AKM932	151
KM1S	136	LM0U06	157	MRE000AAK358	149	MRE000AKN933	149
KM1S0H	136	LM0U0A	157	MRE000AAL129	149	MRE000AKP934	162
KM1U	157	LM13	144	MRE000AAL359	162	MRE000AKP935	149
KMK406	153	LM14	153	MRE000AAM324	151	MRE000AKS938	151
KMR205	143	LM16	145	MRE000AAM554	151	MRE000AKW748	137
KMR20A	143	LM17	153	MRE000AAN361	151	MRE000AKX749	149
KMRG06	152	LM1A	135	MRE000AAN519	151	MRE000AKY750	149
KMS406	153	LM1B	148	MRE000AAN555	149	MRE000AL8953	138
KMS40A	153	LM1C	152	MRE000AAP132	151	MRE000AL9954	149
KMS6B6	145	LM1D	153	MRE000AAP133	149	MRE000ALA955	149
KMSD06	153	LM1E	145	MRE000AAP362	149	MRE000ALB956	162
KMSEB6	144	LM1F	144	MRE000AAP363	151	MRE000ALC957	154
KMSFB5	144	LM1G	152	MRE000AAP520	137	MRE000ALD958	149
KMSK06	156	LM1G06	152	MRE000AAP557	154	MRE000ALE959	154
LA00	147	LM1K	156	MRE000AAP617	149	MRE000ALJ963	154
LA01	152	LM1M	157	MRE000AAP618	149	MRE000ALP642	138
LA04	147	LM1N	157	MRE000AAP776	149	MRE000ALP643	149
LA05	152	LM1N06	157	MRE000AAP909	151	MRE000ALQ644	149
LA0505	152	LM1S	135	MRE000AAQ134	154	MRE000ALR645	162
LA07	162	LM1S0H	135	MRE000AAQ558	154	MRE000ALS646	154
LA08	155	LM1U	157	MRE000AAR293	137	MRE000ALT647	149
LA0A	151	LMK406	153	MRE000AAR559	154	MRE000ALU648	154
LA0A05	151	LMR20A	143	MRE000AAR620	159	MRE000ALV649	162
LA0B	147	LMR2C5	144	MRE000AAR778	151	MRE000AN3946	162
LA0B02	147	LMRG06	152	MRE000AAS524	151	MRE000AN4947	162
LA0D	136	LMS406	153	MRE000AAS621	162	MRE000AN5948	162
LA0E	137	LMS40A	153	MRE000AAT525	149	MRE000AN6949	149
LA0E05	137	LMSD06	153	MRE000AAT622	149	MRE000AN7950	149
LA0F	149	LMSEC6	145	MRE000AAU296	162	MRE000AN8951	162
LA0F02	149	LMSFB5	144	MRE000AAU562	149	MRE001AA2084	151
LA0F0F	149	LMSK06	156	MRE000AAU623	149	MRE001AA3085	137
LA0G	162	MRE000AA0144	151	MRE000AAU781	149	MRE001AA5087	149
LA0G05	162	MRE000AA1145	137	MRE000AAU914	151	MRE001AA6088	149
LA0G0C	162	MRE000AA1278	138	MRE000AAV297	151	MRE001AA7089	162
LA0K	154	MRE000AA2279	149	MRE000AAV527	154	MRE001AA9091	155
LA0L	149	MRE000AA2340	138	MRE000AAV624	162	MRE001AAA092	162
LA0L05	149	MRE000AA2922	155	MRE000AAW140	149	MRE001AAV077	137
LA0N	155	MRE000AA3280	149	MRE000AAW298	149	MRE001AAW078	149
LA0N05	155	MRE000AA3341	149	MRE000AAW528	154	MRE001AAZ081	162
LA0R	151	MRE000AA4281	162	MRE000AAW564	151	MRE001AJL058	162
LA0S	149	MRE000AA4342	149	MRE000AAX141	162	MRE001AJN060	149
LA0U	151	MRE000AA4766	137	MRE000AAX917	149	MRE001AJP061	162
LA0V	137	MRE000AA5149	151	MRE000AAY142	159	MRE001AJP062	162
LA0W	136	MRE000AA5343	162	MRE000AAY300	154	MRE001AK0072	162
LA0Y	154	MRE000AA6150	149	MRE000AAY918	149	MRE001AK3075	151
LA0Y05	154	MRE000AA6344	154	MRE000AAZ301	154	MRE001AK4076	162
LA10	136	MRE000AA6768	149	MRE000AAZ531	137	MRE001AKR063	137
LA11	147	MRE000AA7284	154	MRE000AJ5625	162	MRE001AKT065	149
LA12	150	MRE000AA8152	154	MRE000AJ6626	149	MRE001AKY070	151
LA1A	150	MRE000AA8346	154	MRE000AJ7627	149	MRE001AKZ071	149
LA1C	147	MRE000AAA287	149	MRE000AJ9762	162	MRE001AL0132	154
LA1H	136	MRE000AAA772	154	MRE000AJA763	149	MRE001AL1097	154
LA1J	147	MRE000AAB288	136	MRE000AJB764	149	MRE001AL1133	151
LA1K	147	MRE000AAC289	159	MRE000AJS939	162	MRE001AL2134	151
LA1M	150	MRE000AAC350	149	MRE000AJU941	149	MRE001AL3099	154
LA1R	150	MRE000AAD351	162	MRE000AK1753	151	MRE001AL4136	154
LA1U	155	MRE000AAE122	149	MRE000AK3755	151	MRE001AL6138	162
LM00	152	MRE000AAE316	151	MRE000AK4756	151	MRE001AL7103	154
LM02	143	MRE000AAE352	159	MRE000AK5757	149	MRE001AL8104	162
LM05	157	MRE000AAF123	149	MRE000AK6758	162	MRE001ALE631	138
LM08	134	MRE000AAF317	137	MRE000AK7759	149	MRE001ALF632	149
LM0B	135	MRE000AAG124	149	MRE000AK9628	151	MRE001ALG633	149
LM0B0H	135	MRE000AAG318	149	MRE000AKA629	137	MRE001ALM093	138
LM0C	148	MRE000AAH125	162	MRE000AKB630	149	MRE001ALM639	154
LM0COH	148	MRE000AAH319	149	MRE000AKC631	149	MRE001ALN094	149
LM0F	141	MRE000AAH355	151	MRE000AKD632	162	MRE001ALN640	151
LM0FC5	141	MRE000AAH549	151	MRE000AKE924	137	MRE001ALP095	149
LM0G	152	MRE000AAJ126	162	MRE000AKG926	149	MRE001ALP096	162
LM0H	135	MRE000AAJ320	162	MRE000AKH636	151	MRE001ALP641	155
LM0J	148	MRE000AAJ321	162	MRE000AKJ637	151	MRE001ALP642	162
LM0J0A	148	MRE000AAJ356	137	MRE000AKJ928	162	MRE001ALQ643	162

* C.N.I.T. = Code National d'Identification du Type (code D2.1 sur nouvelles cartes grises)

Type Mines OU C.N.I.T.*	Encadré N°	Type Mines OU C.N.I.T.*	Encadré N°	Type Mines OU C.N.I.T.*	Encadré N°	Type Mines OU C.N.I.T.*	Encadré N°
MRE001ALU126	138	MRE1301AE786	147	MRE1525AU032	157	MRE3512AH250	157
MRE001ALV127	149	MRE1301AG788	147	MRE1525AY036	157	MRE3514A2389	157
MRE001ALW125	149	MRE1301AJ766	147	MRE1601A4660	160	MRE3515AE496	157
MRE001ALW128	149	MRE1301AN831	147	MRE1601A7239	162	MRE3515AF497	157
MRE001ALX129	162	MRE1302A8656	147	MRE1601A8567	162	MRE3525A1033	157
MRE001ALY130	162	MRE1302AC951	147	MRE1601AG733	159	MRE5002A4210	151
MRE001ALZ131	162	MRE1302AE953	147	MRE1601AN122	162	MRE5002A5671	151
MRE001ANJ051	159	MRE1302AH762	147	MRE1601AR902	160	MRE5002A9578	151
MRE001ANJ052	162	MRE1302AJ764	147	MRE1602A6175	159	MRE5002AH126	151
MRE001ANL054	149	MRE1302AK668	147	MRE1605A3457	159	MRE5002AM167	151
MRE001ANM055	162	MRE1302AR833	147	MRE1605AN732	159	MRE5002AN811	151
MRE001ANN056	155	MRE1302AT835	147	MRE1605AW450	159	MRE5002AP558	151
MRE001ANP057	162	MRE1304A0838	147	MRE1605AW644	160	MRE5002AP812	151
MRE1102A3211	137	MRE1304A7651	147	MRE1605AX900	157	MRE5002AR815	151
MRE1102A3247	138	MRE1304AK955	147	MRE1615AF105	157	MRE5002AT271	151
MRE1102A3574	137	MRE1304AR768	147	MRE1615AK085	157	MRE5002AT659	151
MRE1102AJ554	137	MRE1305A0836	147	MRE1711AX642	161	MRE5002AU272	151
MRE1102AK264	138	MRE1305A5647	147	MRE1712AS635	161	MRE5004A8767	151
MRE1102AL168	137	MRE1305AL954	147	MRE1715A9646	161	MRE5004AR653	151
MRE1102AN655	137	MRE1305AV770	147	MRE1715AM756	161	MRE5006AC537	151
MRE1102AP559	137	MRE1306AM626	162	MRE1721AE586	161	MRE5006AD538	151
MRE1102AQ622	137	MRE1311AP638	136	MRE1721AW895	161	MRE5006AP549	151
MRE1102AR562	137	MRE1312AB367	135	MRE1721AX896	161	MRE5006AU749	151
MRE1102AV178	137	MRE1312AE237	136	MRE1722AE584	161	MRE5102AV942	155
MRE1102AX180	137	MRE1312AF626	135	MRE1722AW893	161	MRE5104AU937	155
MRE1102AX241	138	MRE1312AG239	136	MRE1722AX894	161	MRE5111A3236	139
MRE1102AZ667	137	MRE1312AG627	135	MRE1725AH035	161	MRE5111AL351	139
MRE1104AL649	138	MRE1312AK631	136	MRE1912A0490	163	MRE5111AZ523	139
MRE1106A2529	138	MRE1312AL632	136	MRE1922AX583	163	MRE5112A0364	139
MRE1106A7534	138	MRE1314AU382	136	MRE1932AZ135	163	MRE5112A0522	139
MRE1106AG543	138	MRE1314AV383	136	MRE3201A3233	149	MRE5112A4235	139
MRE1111A4637	136	MRE1321A5071	136	MRE3202A0555	149	MRE5112AB533	139
MRE1111A6312	136	MRE1322A3067	136	MRE3202A1265	149	MRE5112AC534	139
MRE1112A7311	136	MRE1322AZ063	135	MRE3202A2169	149	MRE5112AM350	139
MRE1112AZ630	136	MRE1324AE074	136	MRE3202AK212	149	MRE5112AZ363	139
MRE1201A3663	136	MRE1401AM238	162	MRE3202AK575	149	MRE5114AK380	142
MRE1201A3882	136	MRE1401AS571	162	MRE3206AK531	149	MRE5114AM540	142
MRE1201A7570	149	MRE1402A3217	162	MRE3206AY545	149	MRE5202A5166	154
MRE1201AR227	149	MRE1402AJ268	162	MRE3301A1706	147	MRE5202A5263	154
MRE1201AS943	136	MRE1402AK270	162	MRE3301AJ881	147	MRE5202AK181	154
MRE1201AY234	149	MRE1402AL174	162	MRE3302A0703	147	MRE5202AQ248	154
MRE1201AZ235	149	MRE1402AR920	150	MRE3302A1704	147	MRE5211AL923	139
MRE1202A0198	149	MRE1404AU919	150	MRE3302AM883	147	MRE5212AH917	139
MRE1202A0561	149	MRE1405AE452	162	MRE3302AS889	147	MRE5212AJ918	144
MRE1202A0816	136	MRE1405AJ456	162	MRE3305A0891	147	MRE5212AL921	139
MRE1202A1781	136	MRE1406A8541	162	MRE3305A5702	147	MRE5214AJ925	144
MRE1202A7884	136	MRE1411AR242	148	MRE3401A0573	162	MRE5214AT925	144
MRE1202A9146	149	MRE1412AP370	148	MRE3401AR237	162	MRE5221A9777	139
MRE1202A9243	149	MRE1412AP371	148	MRE3402A8216	162	MRE5222AK786	139
MRE1202AB888	136	MRE1412AS241	148	MRE3402AP269	162	MRE5222AY775	141
MRE1202AG214	149	MRE1412AU243	148	MRE3402AQ173	162	MRE5222AZ510	139
MRE1202AJ579	149	MRE1412AW051	150	MRE3405AN455	162	MRE5224A2509	144
MRE1202AK254	149	MRE1414A2053	150	MRE3406AD540	162	MRE5224A3607	142
MRE1202AQ939	136	MRE1414A6384	148	MRE3406AP552	162	MRE5224A4608	144
MRE1202AS941	136	MRE1414A7385	148	MRE3411A8314	148	MRE5224A5609	142
MRE1202AV132	149	MRE1414AM037	150	MRE3412A9313	148	MRE5224AL589	144
MRE1202AW266	149	MRE1415AT491	148	MRE3412AB315	148	MRE5224AL783	142
MRE1202AX170	149	MRE1415AU492	148	MRE3412AB581	146	MRE5301AQ240	155
MRE1202AY171	149	MRE1421AD069	146	MRE3412AQ585	148	MRE5301AQ664	155
MRE1202AZ657	136	MRE1422AB065	146	MRE3412AW372	148	MRE5301AR787	155
MRE1204AR936	136	MRE1422AN138	146	MRE3414AE386	146	MRE5301AT789	155
MRE1204AS901	136	MRE1424A3150	146	MRE3414AV586	146	MRE5301AV572	155
MRE1204AW650	136	MRE1424AN073	146	MRE3415A1493	148	MRE5302A3251	155
MRE1205AJ890	136	MRE1425AS076	146	MRE3421AJ068	148	MRE5302A9221	155
MRE1205AR449	149	MRE1511A8249	157	MRE3421AK070	146	MRE5302AE165	155
MRE1205AT451	149	MRE1511AJ357	157	MRE3422AD061	148	MRE5302AE262	155
MRE1205AU646	136	MRE1512A1373	157	MRE3422AG064	148	MRE5302AJ582	155
MRE1205AV938	136	MRE1512A2374	157	MRE3422AJ066	146	MRE5302AM658	155
MRE1205AW454	149	MRE1512A9248	157	MRE3422AU139	146	MRE5302AP564	155
MRE1206AD530	149	MRE1512AK356	157	MRE3422AW141	146	MRE5302AP782	155
MRE1206AR544	149	MRE1514AJ387	157	MRE3424AA151	146	MRE5302AR275	155
MRE1212AJ119	136	MRE1514AV388	157	MRE3424AS072	146	MRE5302AR785	155
MRE1212AK120	136	MRE1515A6494	157	MRE3425AX075	148	MRE5302AS179	155
MRE1301AB952	147	MRE1515A7495	157	MRE3511AG251	157	MRE5302AY670	155
MRE1301AC662	147	MRE1525A0778	157	MRE3512A9375	157		

* C.N.I.T. = Code National d'Identification du Type (code D2.1 sur nouvelles cartes grises)

Type Mines OU C.N.I.T.*	Encadré N°	Type Mines OU C.N.I.T.*	Encadré N°	Type Mines OU C.N.I.T.*	Encadré N°	Type Mines OU C.N.I.T.*	Encadré N°
MRE5304AK652	155	MRE5522A8392	153	VRE5002A2271	151	JP1B	166
MRE5304AT783	152	MRE5522A9684	153	VRE5006A2748	151	JP1C	164
MRE5306A8539	155	MRE5522AB880	153	VRE5006A3749	151	JP1CF5	164
MRE5306AK551	155	MRE5522AH692	153	VRE5006AL537	151	JP1F	165
MRE5311AN527	140	MRE5522AJ403	153	VRE5006AM538	151	JP1FF5	165
MRE5311AU922	145	MRE5522AS872	153	VRE5006AX549	151	JP1SF5	164
MRE5312AM366	144	MRE5524AD878	153	VRE5006AY550	151	JP3705	166
MRE5312AM754	144	MRE5524AF176	153	VRE5212AH917	139	JP37F5	166
MRE5312AP526	144	MRE5524AJ690	153	VRE5212AL921	139	JP3B05	166
MRE5312AQ916	145	MRE5524AK400	153	VRE5221A9777	144	JP3BF5	166
MRE5312AT919	145	MRE5525AD039	153	VRE5222AK786	139	JP3C05	164
MRE5312AU920	145	MRE5525AD876	153	VRE5222AZ510	139	JPGCF5	164
MRE5312AX535	144	MRE5525AJ688	153	VRE5322AE612	145	MRE1016SQ993	164
MRE5312AY536	144	MRE5525AK398	153			MRE1026SK210	164
MRE5314A2924	144	MRE5621AC776	156	Modus		MRE1026SP409	164
MRE5314A7541	143	MRE5621AJ007	156	FPOC	164	MRE1026SQ410	164
MRE5314AR755	143	MRE5621AL397	156	FPOC05	164	MRE1116S7745	164
MRE5321A0600	145	MRE5621AW602	156	FPOD	167	MRE1116SB749	164
MRE5321A1601	145	MRE5622A1774	156	FPOD05	167	MRE1116SV988	164
MRE5322A0598	145	MRE5622AJ005	156	FPOE	166	MRE1116SW989	164
MRE5322AE612	145	MRE5622AK006	156	FPOE05	166	MRE1116SY991	164
MRE5322AS590	145	MRE5622AK394	156	FPOG	166	MRE1136S1058	164
MRE5322AZ597	145	MRE5622AV405	156	FPOG05	166	MRE1136SV052	164
MRE5324AA604	144	MRE5622AV599	156	FPOK	164	MRE1216S1826	169
MRE5324AB605	144	MRE5624AN781	156	FPOK05	164	MRE1226SH550	169
MRE5324AC606	144	MRE5624AQ008	156	JPO1	165	MRE1316SU748	165
MRE5324AU588	144	MRE5624AW402	156	JPO105	165	MRE1326SJ542	165
MRE5325AB603	145	MRE5625AN779	156	JPO8	166	MRE1326SL156	165
MRE5325AZ275	145	MRE5625AP077	156	JPO805	166	MRE1416S0744	170
MRE5411AB965	153	MRE5631A6065	156	JPO9	167	MRE1426SJ787	170
MRE5411AR521	152	MRE5632A7064	156	JPO9F6	167	MRE1426SU543	170
MRE5411AV525	153	MRE7302A0763	155	JPOA	165	MRE1436S0257	170
MRE5412A2530	152	MRE7302AY761	155	JPOA05	165	MRE1436S2259	170
MRE5412A9246	152	MRE7312A4694	143	JPOB	170	MRE1436S7034	170
MRE5412AC964	153	MRE7312A5695	140	JPOB05	170	MRE1436S9036	170
MRE5412AE348	152	MRE7314AB697	143	JPOB0A	170	MRE3416SQ764	170
MRE5412AJ352	152	MRE7525AK173	153	JPOBFA	170	MRE3426S1544	170
MRE5412AQ360	152	MRE9304AG769	147	JPOC	164	MRE3426SQ788	170
MRE5412AR361	152	MRE9324AA4780	148	JPOC05	164	MRE3426SU889	170
MRE5412AS520	152	SA05	152	JPOCF5	164	MRE3436S6221	170
MRE5412AW233	152	SA0505	152	JPOD	167	MRE3436S7258	170
MRE5412AW524	152	SA09	154	JPOD05	167	MRE3436S9260	170
MRE5414AB377	152	SA0905	154	JPOE	166	MRE3436SE035	170
MRE5414AC378	152	SA0A	151	JPOE05MO	166	MRE3436SG037	170
MRE5414AD537	152	SA0A05	151	JPOF	167	MRE5016SB747	166
MRE5414AE538	153	SA0N	155	JPOF05	167	MRE5016SC845	166
MRE5415AC498	152	SA0N05	155	JPOF06	167	MRE5026S6547	166
MRE5415AD499	152	SA0R	151	JPOF0H	167	MRE5036SN103	166
MRE5415AK542	152	SA0R05	151	JPOFF5	167	MRE5036SP044	166
MRE5415AL543	152	SA0U	151	JPOFFH	167	MRE5036SP104	166
MRE5421A0687	153	SA0U05	151	JPOG	166	MRE5036SQ045	166
MRE5421AU171	153	SA0Y	154	JPOG05	166	MRE5116SK746	167
MRE5422A0685	153	SA0Y05	154	JPOGF5	166	MRE5216SC825	167
MRE5422A8693	153	SA1U	155	JPOH	168	MRE5216SJ990	167
MRE5422AA404	153	SA1U05	155	JPOH06	168	MRE5226SC084	167
MRE5422AT168	153	SM02	144	JPOHF6	168	MRE5226SK408	167
MRE5422AU873	153	SM0F	139	JPOJ	165	MRE5226SP545	167
MRE5422AZ393	153	SM1E	145	JPOJ05	165	MRE5236S3038	167
MRE5424A8179	153	SM1F	144	JPOK	164	MRE5236S5040	167
MRE5424A9180	153	URE5221A9777	144	JPOK05	164	MRE5236S8201	167
MRE5424AA691	153	URE5314A2924	144	JPOL	169	MRE5236ST222	167
MRE5424AB401	153	URE5524AK400	153	JPOL05	169	MRE5236SV030	167
MRE5425A2038	152	URE5621AL397	156	JPOP	164	MRE5236SV224	167
MRE5425A4040	152	VRE000AAG284	154	JPOP05	164	MRE5236SW031	167
MRE5425A5041	152	VRE000AAH346	151	JPOS	164	MRE5316SP986	168
MRE5425AA689	153	VRE000AL3648	154	JPOS05	164	MRE5336SF198	168
MRE5425AB399	153	VRE000ALN959	151	JPOS0H	164	MRE5336SG199	168
MRE5511AA882	153	VRE000ALR963	151	JPOT	164	MRE5336SL046	168
MRE5512AA880	153	VRE001AL9132	151	JPOT05	164	MRE5336SM047	168
MRE5512AB881	153	VRE001ALA133	151	JPOU	170	URE5216SJ990	167
MRE5514AH883	153	VRE001ALC099	151	JPOU05	170	VRE1116S749	164
MRE5515AK884	153	VRE001ALD136	151	JPOU0A	170	VRE5016S744	166
MRE5521A3874	153	VRE001ALG103	151	JPOV	169	VRE5116S746	167
MRE5521A9395	153	VRE001ALV639	151	JPOV05	169		
MRE5521A9686	153	VRE001ALX641	151	JP17	166	R11	

* C.N.I.T. = Code National d'Identification du Type (code D2.1 sur nouvelles cartes grises)

Type Mines OU C.N.I.T.*	Encadré N°	Type Mines OU C.N.I.T.*	Encadré N°	Type Mines OU C.N.I.T.*	Encadré N°	Type Mines OU C.N.I.T.*	Encadré N°
B37100	195	135B	208	C53705	212	B48E05A	220
B37200	197	135B01	208	C53805	215	B48F05	220
B37300	197	235400	207	C53905	216	B48H04	221
B37300A	197	R19		C53A01	212	B48H05	221
B37300AB	197			C53A05	212	B48K02	226
B37301	197	353A05	215	C53B01	213	B48K05	226
B37400	199	353C05	215	C53B05	213	B48P05	225
B37500	198	353D05	215	C53C02	213	B48R05	223
B37600	200	353F02	215	C53C05	213	B48R08	223
B37600BC	200	453A05	215	C53D05	216	B48U02	219
B37601	200	453C05	215	C53E05	213	B48V05	225
B37A	197	453F02	215	C53I05	217	B48W05	225
B37C00	197	453H02	215	C53J05	217	B48Y08	223
B37D00	200	453H05	215	C53K05	218	K48005	225
B37E00	200	553A05	215	C53M05	213	K481	220
B37F00	200	553C05	215	C53P04	210	K48104	220
B37L00	200	553D05	215	C53P05	210	K48105	220
B37N00	200	553F02	215	C53T05	218	K481F4	220
B37R00	197	553H02	215	C53V02	215	K481F5	220
B37S00	196	553H05	215	C53W04	209	K482	220
C37100	195	853A05	215	C53W05	209	K48204	220
C37200	197	853C05	215	C53Z05	218	K48205	220
C37300	197	853F02	215	D53C02	213	K48205A	220
C37301	197	B53004	209	D53C05	213	K482F5	220
C37400	199	B53005	209	D53D05	216	K482F5A	220
C37500	198	B53104	210	D53V02	215	K483	222
C3750087	198	B53105	210	D53Y02	215	K48302	222
C37600	200	B53204	211	D53Y05	215	K48305	222
C37C00	197	B53205	210	D53Y42	215	K48308	222
C37D00	200	B53302	213	D53Y45	215	K483F2	222
C37E00	200	B53305	213	L53004	209	K483F5	222
C37F00	200	B53305A	213	L53005	209	K483K2	222
C37L00	200	B53405	217	L53104	211	K483K5	222
C37N00	200	B53405A	217	L53105	211	K48405	220
C37R00	197	B53505	212	L53204	211	K48605	225
C37S00	196	B53605	213	L53205	211	K48608	225
S37100	195	B53701	212	L53405	217	K486F5	225
S37200	197	B53704	212	L53505	212	K48705	225
S37400	199	B53705	212	L53605	213	K48805	225
S37S00	196	B53705BC	212	L53704	211	K488F5	225
R12		B53805	215	L53705	211	K48902	222
	R1170	B53905	216	L53805	215	K48905	222
R18		B53A01	212	L53905	216	K48C02	222
		B53A05	212	L53B01	213	K48C05	222
134100	202	B53B01	213	L53B05	213	K48E05	220
134101	202	B53B05	213	L53C02	213	K48F05	220
134102	202	B53C02	213	L53C05	213	K48H05	221
134200	203	B53C05	213	L53D05	216	K48HF5	221
134201	203	B53D05	216	L53F05	213	K48K02	226
134300	205	B53E05	213	L53H04	211	K48K05	226
134301	205	B53G05	212	L53H05	211	K48K08	226
134400	206	B53H04	210	L53I05	217	K48M	220
134401	206	B53H05	210	L53J05	217	K48M04	220
134402	206	B53I05	217	L53K05	218	K48M05	220
134500	204	B53J05	217	L53P04	211	K48N05	220
134A00	204	B53K05	218	L53P05	211	K48P05	225
1351	202	B53M05	213	L53T05	218	K48R05	223
135100	202	B53P04	210	S53004	209	K48S02	222
135101	202	B53P05	210	S53005	209	K48S05	222
135102	202	B53T05	218	S53405	217	K48V05	225
135104	202	B53V02	215	S53105	217	K48V08	225
135108	202	B53W04	209	S53J05	217	K48VF5	225
135200	203	B53W05	209	S53K05	217	K48W05	225
135201	203	B53Z05	218	R21		L48005	225
135300	205	C53004	209				L48104
135301	205	C53005	209	B48005	225	L48105	220
135400	207	C53104	210	B48204	220	L48202	220
135401	207	C53105	210	B48205	220	L48204	220
135402	207	C53204	211	B48205A	220	L48205	220
135500	204	C53205	211	B48605	225	L48205A	220
135600	207	C53302	213	B48705	225	L48301	222
135800	202	C53305	213	B48805	225	L48302	222
135801	202	C53405	217	B48D05	219	L48305	222
135A	204	C53505	212	B48E02	220	L48405	220
		C53701	212	B48E05	220	L48505	224

* C.N.I.T. = Code National d'Identification du Type (code D2.1 sur nouvelles cartes grises)

Type Mines OU C.N.I.T.*	Encadré N°	Type Mines OU C.N.I.T.*	Encadré N°	Type Mines OU C.N.I.T.*	Encadré N°	Type Mines OU C.N.I.T.*	Encadré N°
L48508	224	R4		S40405	186	F40NK5	241
L48705	225	112300	171	R6		F40NM5	241
L48805	225	112800	175	R1181	188	F40NP5	241
L48805E	225	112C00	172	R9		F40P	241
L48902	222	239B00	175	L42100	189	F40P05	241
L48905	222	3C2370	175	L42102	189	F40P35	241
L48A05	225	R1123	171	L42200	191	F40PK5	241
L48C02	222	R1128	175	L42202	191	F40PL5	241
L48C05	222	R112C	172	L42300	191	F40PM5	241
L48D05	219	R2370	175	L42301	191	F40PN5	241
L48E02	220	R239B	175	L42302	191	F40PP5	241
L48E05	220	R2430	175	L42400	193	F40PS5	241
L48F05	220	R5		L42500	192	F40R04	241
L48H05	221	122700	178	L42600	194	F40R05	241
L48I05	221	122900	181	L42601	194	F40RM5	241
L48J05	222	122901	181	L42C00	191	F40RP5	241
L48K02	226	122B00	182	L42C02	191	F40RV4	241
L48K05	226	139200	176	L42E00	194	F40RV5	241
L48L05	224	139700	178	L42F	194	F40RW5	241
L48L08	224	139900	181	L42F00	194	F40S01	239
L48M04	220	139901	181	L42J00	191	F40S05	239
L48M05	220	238700	178	L42L00	194	F40SM1	239
L48N05	220	822000	182	L42N00	194	F40SM5	239
L48O05	225	B40004	177	L42R00	191	F40T04	236
L48P05	225	B40005	177	L42S00	190	F40T05	236
L48Q05	223	B40104	179	Rapid		F40TM5	236
L48Q08	223	B40105	179	F400	235	F40U05	239
L48R05	223	B40205	183	F40004	235	F40UM5	239
L48R08	223	B40301	183	F40004A	235	F40UP2	239
L48S02	222	B40305	183	F400M4	235	F40UP5	239
L48S05	222	B40404	186	F401	236	F40UV5	239
L48U01	219	B40405	186	F40104	236	F40V05	239
L48U05	219	B40705	183	F40105	236	F40VM5	239
L48V05	225	B40801	187	F401K4	236	F40VP5	239
L48V05E	225	B40805	187	F401K5	236	G40A05	237
L48W05	225	B40F04	180	F401M4	236	G40AM5	237
L48Y05	223	B40F05	180	F401M5	236	G40B05	241
L48Y08	223	B40G05	187	F401P4	236	G40BM5	241
S48005	225	B40H04	179	F401P5	236	G40BP5	241
S48104	220	B40H05	179	F402	238	G40BV5	241
S48105	220	B40J01	183	F40205	238	G40BW5	241
S48205	220	B40J05	183	F402M5	238	G40C05	241
S48H05	221	B40K05	187	F404	240	G40CM5	241
S48V05	225	B40M05	183	F40404	240	G40CP5	241
R25		C40004	177	F40404A	240	MRE000AGU653	241
B29005	230	C40005	177	F40405	240	MRE5004GJ384	241
B29202	228	C40104	179	F40405A	240	VRE5004GR383	241
B29205	228	C40105	179	F404K5	240	Rodeo	
B29302	233	C40205	183	F404M4	240	5E1128	242
B29305	233	C40301	183	F404M4A	240	ACL2B	242
B29405	228	C40305	183	F404M5	240	Safrane	
B29605	229	C40404	186	F404P4	240	B54002	243
B29701	227	C40405	186	F404P5	240	B54005	243
B29705	227	C40505	185	F40604	237	B54005A	243
B29705A	227	C40705	183	F40605	237	B54102	247
B29801	232	C40801	187	F406M5	237	B54105	247
B29805	232	C40805	187	F406V4	237	B54202	244
B29A05	233	C40905	187	F406V5	237	B54205	244
B29B02	231	C40F04	180	F40705	238	B54302	248
B29B05	231	C40F05	180	F407M5	238	B54305	248
B29E01/1A	231	C40G05	187	F40DM5	239	B54605	246
B29E02	231	C40H04	179	F40E05	241	B54802	250
B29E05	231	C40H05	179	F40EK5	241	B54805	250
B29E05A	231	C40J01	183	F40EM5	241	B54822	250
B29F02	233	C40J05	183	F40EP5	241	B54E02	243
B29F05	233	C40K05	187	F40EV5	241	B54E05	243
B29H02	227	C40M05	183	F40H04	236	B54G0E	249
B29H05	227	R1222	176	F40H05	236	B54L02	245
B29W05	230	R2382	176	F40HM5	236	B54L05	245
R30		S40004	177	F40M05	238	B54L0C	245
127040	234	S40104	179	F40N	241	B54N02	251
R1270	234	S40105	179	F40N05	241	MRE000AD1663	245
		S40404	186			MRE000AD2337	249

* C.N.I.T. = Code National d'Identification du Type (code D2.1 sur nouvelles cartes grises)

Type Mines OU C.N.I.T.*	Encadré N°	Type Mines OU C.N.I.T.*	Encadré N°	Type Mines OU C.N.I.T.*	Encadré N°	Type Mines OU C.N.I.T.*	Encadré N°	
MRE000AD2664	245	JM14	262	MRE5216AN915	255	LB2A	269	
MRE000AD5667	249	JM15	262	MRE5236AD066	255	LB2B	269	
MRE000AD6668	245	JM16	256	MRE5306A5827	261	LB2E	270	
MRE000ADC311	245	JM17	262	MRE5306A6792	261	LB2K	273	
MRE000ADD312	243	JM1A	252	MRE5306AK551	263	LB3D	269	
MRE000ADF544	249	JM1B	257	MRE5306AK745	263	LB3E	273	
MRE000ADG315	249	JM1D	260	MRE5316AP518	254	LB3G	273	
MRE000ADG545	243	JM1E	256	MRE5316AW914	256	LB3H	273	
MRE000ADH546	245	JM1F	255	MRE5326A1591	254	LB3K	268	
MRE000ADJ256	245	JM1G	262	MRE5326A4594	256	LB3M	272	
MRE000ADJ547	245	JM1G06	262	MRE5326A5595	256	LB8D05	269	
MRE000ADY333	245	JM1K	264	MRE5326A6596	254	LB8K05	268	
MRE000ADZ334	243	JM1M	265	MRE5326AV815	256	LBND05	269	
MRE1502DG156	245	JM1N	265	MRE5326AW428	256	LBND0A	269	
MRE1502DH157	245	JM1S	252	MRE5336A1141	256	LBNM05	272	
MRE3502DL155	245	JM1SOH	252	MRE5336A2142	256			
MRE3802D9695	251	JM1T	266	MRE5336A7147	254	Trafic		
MRE5402DG154	249	JM1U	265	MRE5336AY138	256	ELOA	285	
		JM2A	254	MRE5416AB398	262	ELOB	281	
		JM2C	262	MRE5416AB955	262	ELOC	281	
		JMGDD6	262	MRE5416AJ344	262	ELOD	290	
		JMK406	262	MRE5416AZ519	262	ELOH	282	
		JMK4D6	262	MRE5421AU171	260	ELOL	285	
		JMPK06	264	MRE5426A4426	260	ELOM	282	
		JMRF05	253	MRE5426AX164	260	ELOP	282	
		JMRG06	262	MRE5426AZ166	260	ELOS	282	
		JMS406	262	MRE5516AG878	262	ELBAB6	285	
		JMS40A	262	MRE5526A0678	262	ELBBB5	281	
		JMS506	262	MRE5526AC424	262	ELBCB6	281	
		JMS606	256	MRE5526AC679	262	ELBD6	290	
		JMS706	262	MRE5526AF682	262	ELBDB6	290	
		JMSD06	260	MRE5526AM822	262	ELDBBH	290	
		JMSD0A	260	MRE5536AN143	262	ELBHBH	282	
		JMSE06	256	MRE5536AP144	262	ELBLB6	285	
		JMSF05	255	MRE5536AS148	262	ELBMB6	282	
		JMSK06	264	MRE5626A0086	264	ELBPB6	282	
		JMSK0B	264	MRE5626A5770	264	ELBSB6	282	
		MRE1206A3750	252	MRE5626A6771	264	FLOA	285	
		MRE1206A3944	252	MRE5626A7772	264	FLOB	281	
		MRE1206AH886	252	MRE6306A7887	261	FLOC	281	
		MRE1302AH277	258	MRE6306AB794	261	FLOD	290	
		MRE1306A0773	258	MRE7316AZ074	261	FLOH	282	
		MRE1306A5839	258	MRE7526AR530	260	FLOL	283	
		MRE1306AA747	258	URE5216AN915	255	FLOLA6	283	
		MRE1306AS923	258	URE5626A0086	264	FLOM	282	
		MRE1306AY771	258	URE7526AR530	260	FLON	283	
		MRE1306AZ542	252			FLOP	282	
		MRE1306AZ772	258			FLOS	282	
		MRE1316AL394	252	Sport Spider			FLOW	283
		MRE1326A3059	252	EFOH05	267	FLAAA6	285	
		MRE1326A4060	252	MRE000AA6829	267	FLABA5	281	
		MRE1406A0921	259	MRE000AA7830	267	FLACA6	281	
		MRE1406A4828	259	MRE1605JW477	267	FLADA6	290	
		MRE1416AP035	259	MRE1605JX478	267	FLADAH	290	
		MRE1416AP072	259			FLAHA6	282	
		MRE1416AX396	257			FLAHAA	282	
		MRE1516AB400	265	LB01	273	FLAMA6	282	
		MRE1516AC401	265	LB03	268	FLAPA6	282	
		MRE1606A9752	265	LB07	270	FLASA6	282	
		MRE1606AN791	265	LB07CF	270	FLBAA6	285	
		MRE1606AY899	265	LB0B	268	FLBAB6	285	
		MRE1616AL084	265	LB0K	269	FLBAC6	285	
		MRE1716AN622	266	LB0L	269	FLBAD6	285	
		MRE2606AS793	265	LB0P	269	FLBBA5	281	
		MRE2616AG137	265	LB13	269	FLBBB5	281	
		MRE3306AF746	258	LB17	268	FLBBC5	281	
		MRE3306AW885	258	LB18	273	FLBBD5	281	
		MRE3316A4019	258	LB1B	273	FLBCA6	281	
		MRE3416A3590	257	LB1J	273	FLBCB6	281	
		MRE3516AG399	265	LB1R	273	FLBCC6	281	
		MRE3606AR922	265	LB1V	273	FLBCD6	281	
		MRE3606AS790	265	LB1W	270	FLBDA6	290	
		MRE3616AT086	265	LB23	270	FLBDAH	290	
		MRE5116A3517	253	LB24	270	FLBDB6	290	
		MRE5116AC393	253	LB26	273	FLDBBH	290	
				LB29	271			

* C.N.I.T. = Code National d'Identification du Type (code D2.1 sur nouvelles cartes grises)

Type Mines OU C.N.I.T.*	Encadré N°	Type Mines OU C.N.I.T.*	Encadré N°	Type Mines OU C.N.I.T.*	Encadré N°	Type Mines OU C.N.I.T.*	Encadré N°
FLBDC6	290	JLBBB5	281	P358	279	T43F	286
FLBDCH	290	JLBCA6	281	P3X000	276	T4V100	278
FLBDD6	290	JLBCB6	281	P3X110	278	T4V300	286
FLBDDH	290	JLBDA6	290	P3X810	279	T4V800	279
FLBHA6	282	JLBDAH	290	PAY100	278	T4X100	278
FLBHAH	282	JLBDB6	290	PAY200	284	T4X300	286
FLBHB6	282	JLBDBH	290	PAY300	286	T4X405	289
FLBHBH	282	JLBHA6	282	PC82	284	T4X800	279
FLBHC6	282	JLBHAH	282	PC83	286	T4X805	279
FLBHCH	282	JLBHB6	282	PC8F	286	T552	284
FLBHD6	282	JLBHBH	282	PC92	284	T553	286
FLBHDH	282	JLBLB6	283	PC93	286	T554	289
FLBLA6	283	JLBPA6	282	PC9F	286	T558	279
FLBLC6	283	JLBPB6	282	PCG2	284	T55E	287
FLBLD6	283	JLBTA6	282	PCG3	286	T55F	286
FLBMA6	282	JLCAA6	285	PCGF	286	T55G	289
FLBMB6	282	JLCCA6	281	PCY200	284	T55J	280
FLBMC6	282	JLCDA6	290	PCY205	284	T55L	280
FLBMD6	282	JLCDAH	290	PCY300	286	T55M	289
FLBPA6	282	JLCHA6	282	PCY305	286	T5B3	286
FLBPB6	282	JLCHAH	282	PCY400	288	T5B8	279
FLBPC6	282	JLNAA6	285	T110	277	T5BA	287
FLBPD6	282	JLNCA6	281	T118	279	T5BE	287
FLBSA6	282	JLNDA6	290	T11E	287	T5BF	286
FLBSB6	282	JLNDAH	290	T11F	286	T5W100	278
FLBSC6	282	JLNHA6	282	T120	277	T5W300	286
FLBSD6	282	JLNHAH	282	T123	286	T5W800	279
FLFAA6	285	JLNLA6	283	T128	279	T5X000	276
FLFBA5	281	JLPHB6	282	T12E	287	T5X100	278
FLFCA6	281	JLPHBH	282	T12F	286	T5X101	278
FLFHA6	282	MRE1413LD407	283	T1X000	276	T5X200	284
FLFHAH	282	MRE1413LJ255	283	T1X004	277	T5X201	284
FLFMA6	282	MRE1413LM319	283	T1X305	286	T5X205	284
FLFPA6	282	MRE1413LN320	283	T1X805	279	T5X300	286
FLFSA6	282	MRE1423L2467	283	T2B2	284	T5X305	286
FLGAB6	285	MRE1423L3493	283	T2B3	286	T5X405	289
FLGBA5	281	MRE1423L6496	283	T2B4	289	T5X800	279
FLGBB5	281	MRE1423L8473	283	T2B8	279	T5X805	279
FLGCA6	281	MRE1423LD478	283	T2BE	287	T6W100	278
FLGDA6	290	MRE1423LT458	283	T2BF	286	T6W300	286
FLGDAH	290	MRE5113L2256	281	T2W300	286	T7B2	284
FLGDB6	290	MRE5113LG076	281	T2W305	286	T7B3	286
FLGDBH	290	MRE5113LJ078	281	T2W800	279	T7B4	289
FLGHA6	282	MRE5113LJ818	281	T2W805	279	T7BA	287
FLGHAH	282	MRE5113LP048	281	T318	279	T7BB	289
FLGHB6	282	MRE5113LU406	281	T31A	287	T7BG	289
FLGHBH	282	MRE5313L1077	281	T31E	287	T7CA	287
FLGLA6	283	MRE5313L3079	281	T31F	286	T7CE	287
FLGLB6	283	MRE5313L3819	281	T328	279	T7W200	284
FLGMA6	282	MRE5313L4044	281	T32E	287	T7W205	284
FLGMB6	282	MRE5313L5045	281	T32F	286	T7W300	286
FLGPA6	282	MRE5313LD405	281	T333	286	T7W305	286
FLGPB6	282	MRE5313LN257	281	T33F	286	T7W405	289
FLGSA6	282	MRE5313LS323	281	T358	279	T7WA05	287
FLGSB6	282	MRE5423L2455	282	T35A	287	T9X180	278
JLOA	285	MRE5423L7460	282	T35E	287	T9X181	278
JLOB	281	MRE5423L8461	282	T35F	286	T9X380	286
JLOC	281	MRE5423LC490	282	T3V100	278	TAX100	278
JLOD	290	MRE5423LH470	282	T3V300	284	TAX100M	278
JLOH	282	MRE5423LH495	282	T3X100	278	TAX101	278
JLOL	283	MRE5423LM475	282	T3X101	278	TAX300	286
JLON	283	MRE5423LR480	282	T3X300	286	TB12	284
JLOP	282	MRE5423LS481	282	T3X800	279	TB13	286
JLAAA6	285	MRE5433L1453	282	T3X805	279	TB14	289
JLABA5	281	MRE5433LD296	282	T414	289	TB1A	287
JLACA6	281	MRE5433LT287	282	T418	279	TB1B	289
JLADA6	290	MRE5513L0408	290	T41B	289	TB1E	287
JLADAH	290	MRE5513L8707	290	T41E	287	TB1G	289
JLAHA6	282	MRE5513LD324	290	T41F	286	TB22	284
JLAHAH	282	MRE5513LE325	290	T424	289	TB23	286
JLALA6	283	MRE5513LF326	290	T428	279	TB24	289
JLAPA6	282	MRE5513LG327	290	T42B	289	TB2A	287
JLBAA6	285	MRE5513LH328	290	T42E	287	TB2B	289
JLBAB6	285	MRE5513LJ329	290	T42F	286	TB2E	287
JLBAA5	281	P318	279	T434	289	TB2G	289

* C.N.I.T. = Code National d'Identification du Type (code D2.1 sur nouvelles cartes grises)

Type Mines OU C.N.I.T.*	Encadré N°	Type Mines OU C.N.I.T.*	Encadré N°	Type Mines OU C.N.I.T.*	Encadré N°	Type Mines OU C.N.I.T.*	Encadré N°
TB33	286	V41A	287	CNOE	296	S068M5	292
TB34	289	V422	284	CNOE05	296	S06C	293
TB3G	289	V423	286	CNOK	295	S06K	293
TB42	284	V424	289	CNOV	295	VRE000AF1325	292
TB43	286	V42A	287	CNA05	295	VRE000AF9369	292
TB44	289	V42B	289	CNBA05	295	VRE000AFJ670	292
TB4E	287	V42E	287	CNCA05	295	VRE000AFP676	292
TB4G	289	V42G	289	M10RENV001P196	295	VRE001AF4485	292
TB52	284	V494	289	MRE000AF0369	292	VRE001AF9490	292
TB54	289	V49B	289	MRE000AFA670	292	VRE001AFA042	292
TB5E	287	V4X200	284	MRE000AFU327	292	VRE001AFB043	292
TB5G	289	V4X208	284	MRE000AFY367	292	VRE001AFD045	292
TB62	284	V4X300	286	MRE001AF0490	291	VRE001AFS484	292
TB63	286	V4X308	286	MRE001AF1042	292	VRE1001F7867	292
TB64	289	V4X408	289	MRE001AF2043	292	VRE1001F8868	292
TB6A	287	V4Y408	289	MRE001AF4045	292	VRE1001FF160	292
TB6E	287	V5B2	284	MRE001AFJ484	292	VRE1001FM458	292
TB6G	289	V5B4	289	MRE001AFV485	292	VRE1001FP461	292
TB94	288	V5BA	287	MRE1001F6160	292	VRE1001FR463	292
TB9B	288	V5BB	289	MRE1001F9163	292	VRE1001FT465	291
TB9G	288	V5BE	287	MRE1001FD458	292	VRE1001FU466	291
TBX200	284	V5BG	289	MRE1001FG461	292		
TBX201	284	V5BM	289	MRE1001FJ463	292	Vel Satis	
TBX205	284	V5W100	278	MRE1001FK465	292	BJ01	302
TBX300	286	V5W208	284	MRE1001FL466	291	BJ010B	302
TBX305	286	V5W408	289	MRE1001FS473	292	BJOE	299
TBX405	289	V9X100	278	MRE1001FT474	292	BJOE06	299
TBXA05	287	V9X200	284	MRE1001FY867	292	BJOF	299
TBZ200	284	V9X300	286	MRE1001FZ868	291	BJOF0B	299
TBZ300	286	VRE5003LN437	280	MRE1011FH170	292	BJOG	299
TBZ405	288	VRE5006LD421	280	MRE1011FJ171	292	BJOH	299
TBZ800	279			MRE1011FP141	292	BJOH06	300
TC7G	289	Twingo		MRE1011FY115	292	BJOJ	301
TC94	288	C06005	293	MRE1101F7866	293	BJOK	298
TC9G	288	C0600K	293	MRE1111F9698	293	BJOK06	298
TC9M	289	C061CK	294	MRE1111FD702	293	BJOK0B	298
TCJG	288	C0620K	293	MRE1111FE703	293	BJOM	299
TCJM	288	C062CK	293	MRE1111FG705	293	BJOO	300
TCY405	288	C06305	291	MRE1111FP652	293	BJOP	298
TE1200	284	C0630P	291	MRE1111FV138	293	BJOP06	298
TE1A	287	C06355	291	MRE1111FW139	293	BJOPOB	298
TE2200	284	C0635P	291	MRE1121FD798	295	BJOU	302
TE2A	287	C06405	291	MRE1121UL694	295	BJOV	302
TE9200	284	C0640P	291	MRE1131FQ458	295	BJOV0B	302
TF1G	289	C06455	291	MRE1131FY466	295	BJOW	297
TF1J	280	C06455A	291	MRE3001FB159	292	BJOW06	297
TF1L	280	C0645P	291	MRE3001FL460	292	BJOW0B	298
TF1M	289	C0645PA	291	MRE3001FP464	292	BJR006	300
TF2G	289	C06601	292	MRE3001FP779	292	BJRFOB	299
TF2J	280	C06605	292	MRE3001FP780	292	BJRH0B	300
TF2L	280	C0660E	292	MRE3001FT759	292	BJRM06	300
TF2M	289	C0660G	292	MRE3011F7700	292	MRE1712RB091	298
TF3G	289	C066M1	292	MRE3011F8701	292	MRE1712RQ846	297
TF3J	280	C066M5	292	MRE3011FS757	292	MRE1712RX102	298
TF3L	280	C066M5G	292	MRE3011FT758	292	MRE3712R4103	298
TF3M	289	C066MG	292	MRE5021FJ802	296	MRE3712RD245	298
TG1G	289	C06701	292	MRE5021UQ697	296	MRE3712RX847	298
TH1G	289	C06705	292	MRE5031FW462	296	MRE3912RU098	302
THBJ	280	C0670E	292	MRE9011F8173	292	MRE3922R4046	302
THBL	280	C0670G	292	MRE9011FA588	292	MRE5412R9556	300
TJ1G	289	C068AE	292	MREZ011FZ171	292	MRE5412RT213	300
TMBE	287	C068M5	292	S06305	291	MRE5612RE214	299
TMBF	286	C06C05	293	S06405	291	MRE5612RH095	299
V2W200	284	C06D	293	S0640P	291	MRE5612RU557	300
V312	284	C06D05	293	S06455	291	MRE5612RV558	299
V313	286	C06D0K	293	S06455A	291	MRE7612RA337	299
V314	289	C06G0E	292	S0645P	291	MRE7622RC277	300
V31A	287	C06GN5	292	S0645PA	291	MRE7712RD560	301
V31B	289	C06H05	293	S06601	292	MRE7712RU092	301
V31E	287	C06K	293	S06605	292		
V31G	289	C06W05	293	S0660E	292		
V31M	289	C06W0K	293	S0660G	292		
V3X208	284	CNOA	295	S066M5	292		
V3X308	286	CNOA05	295	S066MG	292		
V412	284	CNOA0H	295	S06805	292		



* C.N.I.T. = Code National d'Identification du Type (code D2.1 sur nouvelles cartes grises)

IDENTIFICATION JOINTS DE CULASSE - Moteur Diesel CYLINDER HEAD GASKET IDENTIFICATION - Diesel Engine RENAULT - F9Q

Moteurs / Engines F9Q

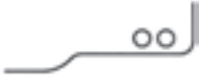

Languette de repérage
Identification area

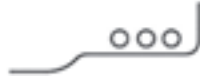
 <p>2 Trous / Holes</p>	 <p>1 Trou / Hole</p>	 <p>3 Trous / Holes</p>
<p>AC5070 Ép. / Thick. = 1,35 mm*</p>	<p>AC5080 Ép. / Thick. = 1,45 mm*</p>	<p>AC5090 Ép. / Thick. = 1,55 mm*</p>
<p>* L'épaisseur correspond à l'épaisseur serrée sur moteur. * The above thickness refers to the assembled thickness.</p>		





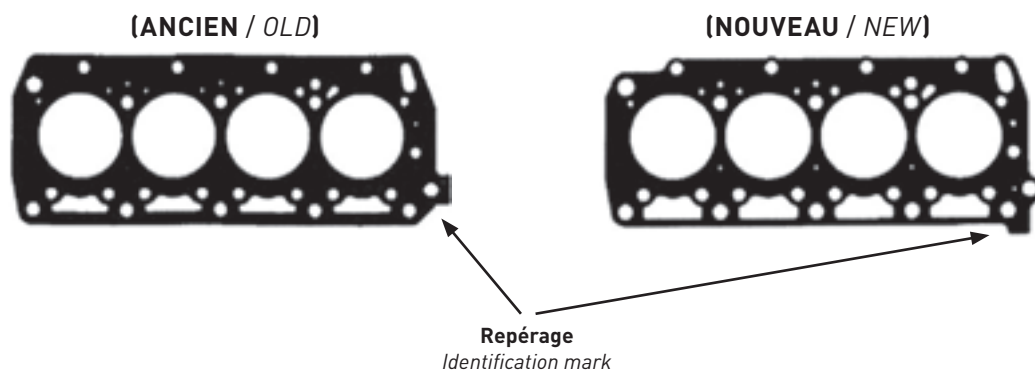

IDENTIFICATION JOINTS DE CULASSE - Moteur Diesel CYLINDER HEAD GASKET IDENTIFICATION - Diesel Engine RENAULT - J8S

Moteurs / Engines J8S

2 types de joints interchangeables / 2 kind of interchangeable gaskets



2 possibilités de repérage / 2 ways of identification

 2 Trous / Holes	 1 Trou / Hole	 3 Trous / Holes
ou / or	ou / or	ou / or
 1 Trou / Hole	 0 Trou / Hole	 2 Trous / Holes
BH 080 Ép. / Thick. = 1,60 mm*	BG 900 Ép. / Thick. = 1,70 mm*	BH 090 Ép. / Thick. = 1,80 mm*
Dépassement pistons: inférieur à 0,960 mm <i>Piston protusion</i> <i>up to 0,960 mm</i>	Dépassement pistons: de 0,960 à 1,040 mm <i>Piston protusion</i> <i>from 0,960 to 1,040 mm</i>	Dépassement pistons: supérieur à 1,040 mm <i>Piston protusion</i> <i>above 1,040 mm</i>







IDENTIFICATION JOINTS DE CULASSE - Moteur Diesel CYLINDER HEAD GASKET IDENTIFICATION - Diesel Engine RENAULT - F8M

Moteurs / Engines **F8M-720** → Avril 1988
F8M-730 → Avril 1988



Repérage /
Identification mark

2 possibilités de repérage / 2 ways of identification

 2 Trous / Holes ou / or  2 Trous / Holes	 0 ou 1 Trou / Hole ou / or  1 Trou / Hole	 3 Trous / Holes ou / or  3 Trous / Holes
<p>BL 960 Ép. / Thick. = 1,65</p>	<p>BL 970 Ép. / Thick. = 1,75</p>	<p>BL 980 Ép. / Thick. = 1,85</p>
<p>Dépassement pistons: inférieur à 0,885 mm Piston protusion up to 0,885 mm</p>	<p>Dépassement pistons: de 0,885 à 0,985 mm Piston protusion from 0,885 to 0,985 mm</p>	<p>Dépassement pistons: supérieur à 985 mm Piston protusion above 0,985 mm</p>

Moteurs / Engines **F8M-730** Avril 1988 →

2 types de joints interchangeables / 2 kind of interchangeable gaskets

(ANCIEN / OLD)









(NOUVEAU / NEW)



Repérage
Identification mark

2 possibilités de repérage / 2 ways of identification

 2 Trous / Holes ou / or  2 Trous / Holes	 0 ou 1 Trou / Hole ou / or  1 Trou / Hole	 3 Trous / Holes ou / or  3 Trous / Holes
<p>BS 010 Ép. / Thick. = 1,65</p>	<p>BS 020 Ép. / Thick. = 1,75</p>	<p>BS 030 Ép. / Thick. = 1,85</p>
<p>Dépassement pistons: inférieur à 0,885 mm Piston protusion up to 0,885 mm</p>	<p>Dépassement pistons: de 0,885 à 0,985 mm Piston protusion from 0,885 to 0,985 mm</p>	<p>Dépassement pistons: supérieur à 985 mm Piston protusion above 0,985 mm</p>







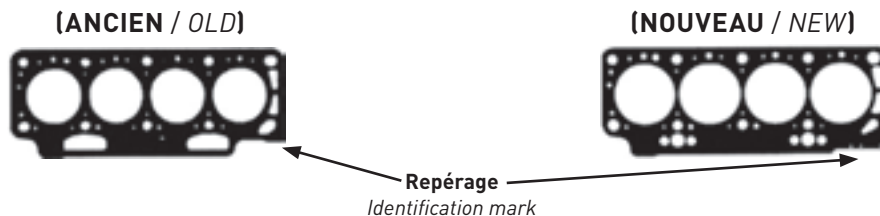

IDENTIFICATION JOINTS DE CULASSE - Moteur Diesel CYLINDER HEAD GASKET IDENTIFICATION - Diesel Engine RENAULT - F8Q

Moteurs / Engines **F8Q Atmo / F8Q N.A.**

2 types de joints interchangeables / 2 kind of interchangeable gaskets





3 possibilités de repérage / 3 ways of identification

 2 Trous / Holes ou / or  2 Trous / Holes ou / or  2 Trous / Holes Identification moteur 2 trous / Engine identification 2 holes	 0 ou 1 Trou / Hole ou / or  0 ou 1 Trou / Hole ou / or  1 Trou / Hole Identification moteur 2 trous / Engine identification 2 holes	 3 Trous / Holes ou / or  3 Trous / Holes ou / or  3 Trous / Holes Identification moteur 2 trous / Engine identification 2 holes
<p>BS 520 Ép. / Thick. = 1,65</p>	<p>BS 530 Ép. / Thick. = 1,75</p>	<p>BS 540 Ép. / Thick. = 1,85</p>
<p>Dépassement pistons: inférieur à 0,868 mm Piston protusion up to 0,868 mm</p>	<p>Dépassement pistons: de 0,868 à 1,000 mm Piston protusion from 0,868 to 1,000 mm</p>	<p>Dépassement pistons: supérieur à 1,000 mm Piston protusion above 1,000 mm</p>

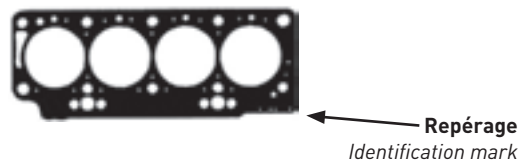
Moteurs / Engines **F8Q Turbo / F8Q T.C.**



 2 Trous / Holes Identification moteur 3 trous / Engine identification 3 holes	 1 Trou / Hole Identification moteur 3 trous / Engine identification 3 holes	 3 Trous / Holes Identification moteur 3 trous / Engine identification 3 holes
<p>AY 710 Ép. / Thick. = 1,40</p>	<p>AY 720 Ép. / Thick. = 1,50</p>	<p>AY 730 Ép. / Thick. = 1,60</p>
<p>Dépassement pistons: inférieur à 0,073 mm Piston protusion up to 0,073 mm</p>	<p>Dépassement pistons: de 0,073 à 0,206 mm Piston protusion from 0,073 to 0,206 mm</p>	<p>Dépassement pistons: supérieur à 0,206 mm Piston protusion above 0,206 mm</p>







RENAULT

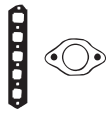

KW/PS

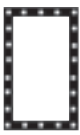

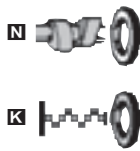
Avantime 2.0L 16V Turbo		11/01 → 05/03		1		AD5990 (MLS) (30-029781-00) AE5110 (MLS) (30-029811-00) AG9320 (MLS) (30-030286-00)	CE5110 (21-29811-20/0)	EE5110 (22-29811-00/0)
F4R 760/F4R 761	1998	4	82.70		120/163			
Avantime 2.2L dCi Diesel		05/02 → 05/03		2		AE5210 (MLS), 1.24mm (30-029250-00)	CE5210	EE5220 (22-29037-00/0)
G9T 712	2188	4	87.00		110/150			
Avantime 3.0L V6		09/01 → 05/03		3		AH5060 (MLS), 0.74mm <input checked="" type="checkbox"/> AH5070 (MLS), 0.95mm <input checked="" type="checkbox"/> AH5040 (MLS), 0.74mm <input checked="" type="checkbox"/> AH5050 (MLS), 0.95mm <input checked="" type="checkbox"/>	CH5060 <input checked="" type="checkbox"/> CH5040 <input checked="" type="checkbox"/>	
L7X 720/L7X 721	2946	6	87.00	MPi	152/207			
B110 2.8L TD Diesel				4		BX420 (Fibre), 1.50mm [71] (30-027884-00)	DX391▲ (21-27867-21/0)	
8140.23.2585	2800	4	94.40	Sofim, Direct Injection, Turbo Intercooled, Euro 2	90/122			
8140.23.2585 (S(WA7)/	2800	4	94.40	Sofim, Turbo Intercooled	90/122			
8140.23.3700								
8140.43.2585	2800	4	94.40	Sofim, Turbo Intercooled, Euro 2	90/122			
8140.43.3700/ 8140.43.3900	2800	4	94.40	Sofim, Turbo Intercooled	90/122			
B120 2.8L TD Diesel				5		BX420 (Fibre), 1.50mm [71] (30-027884-00)	DX391▲ (21-27867-21/0)	
8140.23.2585	2800	4	94.40	Sofim, Direct Injection, Turbo Intercooled, Euro 2	90/122			
8140.23.2585 (S(WA7)/	2800	4	94.40	Sofim, Turbo Intercooled	90/122			
8140.23.3700								
8140.43.2585	2800	4	94.40	Sofim, Turbo Intercooled, Euro 2	90/122			
8140.43.3700/ 8140.43.3900	2800	4	94.40	Sofim, Turbo Intercooled	90/122			
Clio 1.1L		01/91 → 09/98		6		BH680 (Fibre), 1.20mm (30-024764-10) BM790 (Fibre), 1.75mm [34]	DH683■○ (21-24764-25/0) DH687■ DN684■▲○	EH680 (22-20518-01/0)
C1E 700/ C1E 715/C1E 720	1108	4	70.00	Carburettor	35/47			
Clio 1.2L		05/90 → 09/98		7		BX720 (Fibre), 1.35mm (30-026446-10) BX730 (Fibre), 1.75mm [34]	DX720 (21-26446-24/0)	ES580 [36]
Clio Van 1.2L		01/91 → 09/98						
E7F 708/E7F 750	1171	4	75.80	SPi	43-44/ 58-60			
E7F 700/E7F 706	1171	4	75.80	SPi	55/75			
Clio 1.2L		01/96 → 05/05		8		BX630 (Fibre) (30-028934-00)	DX630 (21-28934-20/0)	EA140 (22-28935-00/0)
Clio Van 1.2L		09/98 →						
D7F 710/ D7F 720/ D7F 722/ D7F 726/D7F 730	1149	4	69.00	MPi	44/60			
Clio 1.2L		01/96 → 12/96		9		BV190 (Fibre), 1.25mm (30-027575-00) BX740 (Fibre), 1.75mm [34]	DV190▲ (21-27577-20/0) DX651 (21-27575-20/0) contains BV190	EV190 [36]
C3G 720	1239	4	74.00	SPi	40/54			
Clio 1.2L (B/C/S572)		05/90 → 03/96		10		BX720 (Fibre), 1.35mm (30-026446-10) BX730 (Fibre), 1.75mm [34]	DX720 (21-26446-24/0)	ES580 [36]
ESF 710	1171	4	75.80	Carburettor	40-44/ 55-60			

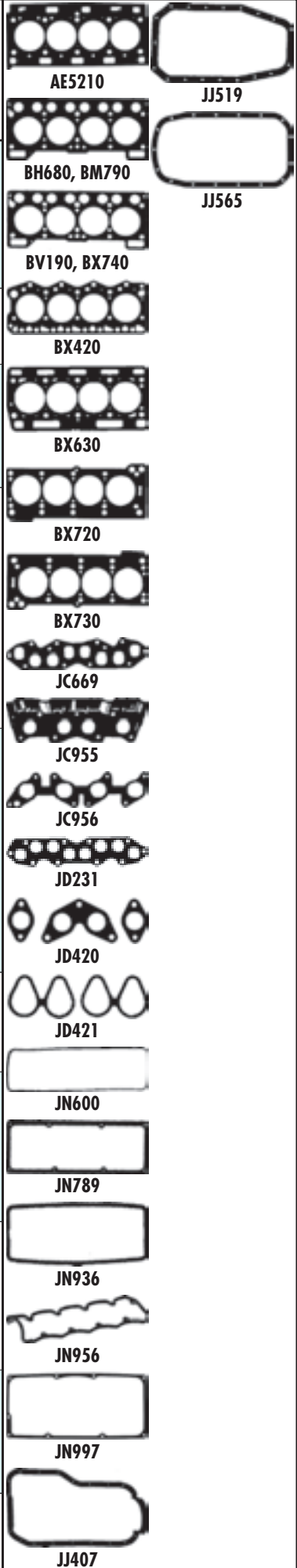
								
HBS310 ⊕ (22-51108B) M12x1.50x117mm (x10)	JD5911 ■ JD5910 ■	HR397 [57] 34-000410-00			NA5257 28x47x5.5mm			AE5210 BH680, BM790 BV190, BX740 BX420 BX630 BX720 BX730 JC669 JC955 JC956 JD231 JD420 JD421 JN600 JN789 JN936 JN956 JN997 JJ407
HBS373 ⊕ (22-51110B) M12x1.50x131mm (x10)	JD5891 ■ JD5892	HM5290 ■			NA5053 (x2) 30x42x7mm, FPM (50-319488-00) NF860 ■ 93x108x7mm, FPM		HL5035 [245] ■	
HBS272 ⊕ (22-53016B) M10x1.50x147mm (x16)	JD5906 ■ JD5907 ■ (x2) ⊕ JE5069 ⊕ JE5070 ⊕ JE5071				NA5260 38x50x6mm			
HBS255 ⊕ (22-17021B) M12x1.25x90mm (x8) M12x1.25x160mm (x14)		JN956	JJ519 (31-025623-00)	HR602 ■ 24-30670-61/0	NP067 50x70x10mm, FPM (50-307111-70) NF885 ■ [3] 70x159x16mm, FPM (50-307266-70) NF883 ■ [3] 114x171x13mm, FPM (50-307265-70)			
HBS255 ⊕ (22-17021B) M12x1.25x90mm (x8) M12x1.25x160mm (x14)		JN956	JJ519 (31-025623-00)	HR602 ■ 24-30670-61/0	NP067 50x70x10mm, FPM (50-307111-70) NF885 ■ [3] 70x159x16mm, FPM (50-307266-70) NF883 ■ [3] 114x171x13mm, FPM (50-307265-70)			
HBS104 ⊕ (22-51005B) M10x1.50x100mm (x10)	JC669 (31-026620-10)	JN600	HC486 ■ ■ PA349 (33-102290-10) 22x16x2mm	HR643 ■	NF834 ■ 35x50x8mm, FPM (50-319241-00) NF835 ■ 80x100x8mm, FPM/ACM (50-319239-00)	HR350 [37] ■ NF791 [38] JR635 [11]		
HBS102 ⊕ (22-51001B) M10x1.50x98mm (x5) M10x1.50x113mm (x5)	JC956 ■ JC955 ■ [133]	JN789 (31-026584-00)	JJ407 ■ PA349 (33-102290-10) 22x16x2mm	HR646 ■ 24-30670-60/0	NA5053 30x42x7mm, FPM (50-319488-00) NA5016 ■ 35x47x7mm, FPM (50-305690-50) NF835 ■ 80x100x8mm, FPM/ACM (50-319239-00)	HL5015 [245] ■ HR658 [37] ■		
HBS241 ⊕ (22-51102B) M9x1.25x103mm (x10)	JD421 ■ JD420 ■	JN997 →01/00 JM5131 (50-029881-00) 01/00 →	JJ565 ■ PA349 (33-102290-10) 22x16x2mm	HR789 ■	NA5053 30x42x7mm, FPM (50-319488-00) NF856 ■ 32x44x6mm, FPM/ACM	HL5021 [245] ■ NF791 [38]		
HBS104 ⊕ (22-51005B) M10x1.50x100mm (x10)	JD231	JN936 (50-027577-00)	HC486 ■ ■ PA349 (33-102290-10) 22x16x2mm	HR643 ■	NF834 ■ 35x50x8mm, FPM (50-319241-00) NF835 ■ 80x100x8mm, FPM/ACM (50-319239-00)	HT025 [37] ■ NF791 [38] LT839 [13] JR635 [11]		
HBS102 ⊕ (22-51001B) M10x1.50x98mm (x5) M10x1.50x113mm (x5)	JC956 ■ JC955 ■	JN789 (31-026584-00)	JJ407 ■ PA349 (33-102290-10) 22x16x2mm	HR656 ■ (24-31939-70/0)	NA5053 30x42x7mm, FPM (50-319488-00) NA5016 ■ 35x47x7mm, FPM (50-305690-50) NF835 ■ 80x100x8mm, FPM/ACM (50-319239-00)	HL5015 [245] ■		



KW/PS



Clio 1.2L 16V		06/01 → 05/05		11		AD5980 (MLS) (30-029780-00) AG7950 (MLS) D4F-712		CD5981		EG7950 D4F-712	
D4F 712/D4F 714	1149	4	69.00	MPi	55/75						
Clio 1.2L 16V		06/05 →		12		AD5980 (MLS) (30-029780-00)		CD5980 (21-29780-20/0)			
D4F 740	1149	4	69.00	MPi	55/75						
D4F 764	1149	4	69.00	MPi	57/77						
Clio 1.2L 16V		02/08 →		13		AD5980 (MLS) (30-029780-00)		CD5980 (21-29780-20/0)			
Clio 1.2L 16V Hi-Flex		07/08 →									
D4F 740	1149	4	69.00	MPi	55/75						
D4F 764	1149	4	69.00	MPi	57/77						
Clio 1.4L		01/91 → 09/98		14		BX720 (Fibre), 1.35mm (30-026446-10) BX730 (Fibre), 1.75mm [34]		DX720 (21-26446-24/0)		ES580 [36]	
E7J 710/E7J 711	1390	4	75.80	SPi	58-59/ 80-80						
Clio 1.4L		01/91 → 09/98		15		BX720 (Fibre), 1.35mm (30-026446-10) BX730 (Fibre), 1.75mm [34]		DS580 (21-26446-22/0) DX720 (21-26446-24/0)		ES580 [36]	
E7J 756/E7J 757	1390	4	75.80	SPi	55/75						
E7J 754	1390	4	75.80	SPi	55-59/ 75-80						
E7J 718/E7J 719	1390	4	75.80	SPi	58/79						
Clio 1.4L		09/98 → 05/05		16		BX720 (Fibre), 1.35mm (30-026446-10) BX730 (Fibre), 1.75mm [34]		DX721 (21-26446-23/0)		ES580 [36]	
E7J 780	1390	4	75.80	SPi	55/75						
Clio 1.4L 16V		10/99 → 05/05		17		AC5100 (MLS), 1.20mm (30-029743-00)		CC5100 (21-29743-20/0)			
K4J 712	1390	4	79.50	MPi	70-72/ 95-98						
K4J 700/ K4J 713/K4J 780	1390	4	79.50	MPi	72/98						
Clio 1.5L D Diesel		08/04 →		18		AE5200 (MLS) (30-029015-00) →05/04		CE5200▲ (21-29015-20/0) →09/03		EE5200	
Clio 1.5L D Mk III Diesel		11/07 →									
Clio 1.5L dCi Diesel		06/01 → 10/06									
Clio 1.5L dCi (B/CB3N) Diesel		02/07 →				AG9490 (MLS) (30-029497-00) 05/04 →					
K9K 700/K9K 704	1461	4	76.00	Direct Injection, SOHC	48/65 62/84						
K9K 752	1461	4	76.00		48/65 48-50/ 65-68						
K9K 714	1461	4	76.00		50/68						
K9K 750	1461	4	76.00		57-65/ 78-88						
K9K 702/K9K 710	1461	4	76.00	Direct Injection	60/81						
K9K 716	1461	4	76.00		60/82						
K9K 718	1461	4	76.00	Direct Injection	62/84						
K9K 740	1461	4	76.00	Direct Injection							
Clio 1.5L dCi Diesel		01/04 → 05/05		19		AE5200 (MLS) (30-029015-00) →05/04				EE5200	
K9K 768	1461	4	76.00		50/68						
K9K 766	1461	4	76.00		63/86						
K9K 712	1461	4	76.00		74/100	AG9490 (MLS) (30-029497-00)					
K9K 764	1461	4	76.00		78/106	05/04 →					

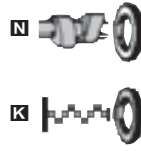
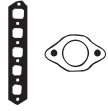

AC5100



AE5200



BX720



BX730



JC955



JC956



JN789













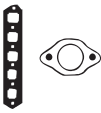

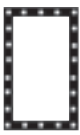

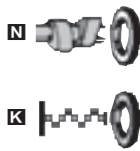















































































JJ407



KW/PS



Clio 1.5L dCi Diesel		06/01 →		20		AE5200 (MLS) (30-029015-00) →05/04 AG9490 (MLS) (30-029497-00)	CE5200▲ (21-29015-20/0) →09/03	EE5200
K9K 700/K9K 704	1461	4	76.00		48/65			
Clio 1.5L dCi Diesel		06/05 →		21		AG9490 (MLS) (30-029497-00) →05/04		EE5200
	1461	4			76/103			
Clio 1.5L dCi (KROF) Diesel		02/08 →		22		AG9490 (MLS) (30-029497-00)		EE5200
Clio 1.5L dCi (KROG) Diesel		02/08 →						
Clio 1.5L dCi (KROH) Diesel		02/08 →						
K9K 768	1461	4	76.00		50/68			
K9K 766	1461	4	76.00		63/86			
K9K 764	1461	4	76.00		78/106			
Clio 1.6L		11/03 →		23		AC5100 (MLS), 1.20mm (30-029743-00)	CC5100 (21-29743-20/0)	
Clio 1.6L 16V		09/98 →05/05						
K4M 746	1598	4	79.50	Injection, DOHC	79/107			
K4M 708/K4M 748	1598	4	79.50	MPi	79/81/ 107/ 109			
Clio 1.6L 16V (KROB)		02/08 →		24		AC5100 (MLS), 1.20mm (30-029743-00)	CC5100 (21-29743-20/0)	
Clio 1.6L 16V		06/05 →						
K4M 804	1598	4	79.50	MPi	65/88			
K4M 800	1598	4	79.50	MPi	82/111			
Clio 1.6L		09/98 →05/05		25		BY030 (Fibre) (30-028797-00)	DY030 (21-28797-20/0)	EA220 (22-28798-00/0)
K7M 744/K7M 745	1598	4	79.50	MPi	66/89			
Clio 1.6L 16V		06/05 →		26		AC5100 (MLS), 1.20mm (30-029743-00)	CC5100 (21-29743-20/0) CC5110	
K4M 800/K4M 801	1598	4	79.50	MPi	82/111			
Clio 1.7L		01/91 →12/93		27		BL910 (Fibre), 1.20mm (30-026613-00)	DL910 DL911 (21-26613-23/0)	EL960 [8] (22-27574-00/0)
F2N 770	1721	4	81.00	Carburettor	66-68/ 90-92			
Clio 1.8L		01/91 →09/98		28		BX600 (Fibre) (30-027850-00)	DX600 (21-27850-20/0)	EL960 [8] (22-27574-00/0)
Clio 1.8L Rsi		01/93 →09/98						
F3P 710	1794	4	82.70	SPi	70/95			
F3P 712	1794	4	82.70	MPi	70/95			
F3P 714	1794	4	82.70	SPi	70/95			
F3P 754/ F3P 755/F3P 758	1794	4	82.70	MPi	70/95			
Clio 1.8L 16V		08/91 →06/94		29		BX610 (Fibre) (30-026980-00)	DX610 (21-26980-21/0)	EL960 [8] (22-27574-00/0)
F7P 722	1763	4	82.00	MPi	101/137			

								
HBS299  [22-29019B] M11x1.50x125.0mm (x10)	JD5402  (31-030008-00)  KK5643 (31-030009-00)	JM7054 (NBR)		HR817  24-30614-78/0	 NA5215 28x42x5mm, FPM  NA5255 35x47x7mm	HL5026 [245] 		 AC5100  AE5200  BL910  BX600  BX610  BY030  JD409  JD410  JD411  JD419  JN732  JN789  JN996  JJ557
HBS299  [22-29019B] M11x1.50x125.0mm (x10)	JD5402  (31-030008-00)  KK5643 (31-030009-00)			HR817  24-30614-78/0	 NA5215 28x42x5mm, FPM			
HBS299  [22-29019B] M11x1.50x125.0mm (x10)	JD5402  (31-030008-00)  KK5643 (31-030009-00)	JM7054 (NBR)	JH5109 (NBR)	HR817  24-30614-78/0	 NA5215 28x42x5mm, FPM  NA5255 35x47x7mm			
HBS301  [22-51107B] M10x1.50x117mm (x10)	JD5393 	HR397 [57] 34-000410-00	JH5108  PA349 (33-102290-10) 22x16x2mm		 NA5215 (x2) 28x42x5mm, FPM  NA5016 35x47x7mm, FPM (50-305690-50)  NF835 80x100x8mm, FPM/ACM (50-319239-00)	HL5029 [245] 		
HBS301  [22-51107B] M10x1.50x117mm (x10)	JD5894   JE5063	HR397 [57] 34-000410-00	JH5109 (NBR)  PA349 (33-102290-10) 22x16x2mm		 NA5215 (x2) 28x42x5mm, FPM  NA5016 35x47x7mm, FPM (50-305690-50)  NF835 80x100x8mm, FPM/ACM (50-319239-00)	HL5029 [245] 		
HBS102  [22-51001B] M10x1.50x98mm (x5) M10x1.50x113mm (x5)	JD434  JD418 	JN789 (31-026584-00)	 PA349 (33-102290-10) 22x16x2mm	HR646  24-30670-60/0	 NA5053 30x42x7mm, FPM (50-319488-00)  NA5016 35x47x7mm, FPM (50-305690-50)  NF835 80x100x8mm, FPM/ACM (50-319239-00)	HL5015 [245]  NF791 [38]		
HBS301  [22-51107B] M10x1.50x117mm (x10)	JD5894   JE5063	HR397 [57] 34-000410-00	JH5109 (NBR)  PA349 (33-102290-10) 22x16x2mm		 NA5215 (x2) 28x42x5mm, FPM  NA5016 35x47x7mm, FPM (50-305690-50)  NF835 80x100x8mm, FPM/ACM (50-319239-00)	HL5029 [245] 		
HBS244  [22-51103B] M12x1.50x111mm (x10)	JD409 (31-026628-10)	JN732 (50-026632-00)	 PA349 (33-102290-10) 22x16x2mm	HR569  24-30667-00/0	 NF846 25x42x7mm, FPM/ACM (50-319516-00)  NF847 22x45x7mm, FPM/ACM  NF843 50x68x10mm, FPM/ACM (50-305667-70)  NF850 85x105x8mm, FPM (50-319183-00)	HL5013 [245]  NF791 [38] KA625 [13] NF849 [15]		
HBS244  [22-51103B] M12x1.50x111mm (x10)	JD419 (31-027573-00)	JN732 (50-026632-00)	 PA349 (33-102290-10) 22x16x2mm	HR569  24-30667-00/0	 NF846 25x42x7mm, FPM/ACM (50-319516-00)  NF847 22x45x7mm, FPM/ACM  NF843 50x68x10mm, FPM/ACM (50-305667-70)  NF850 85x105x8mm, FPM (50-319183-00)	HL5013 [245]  NF791 [38] KA625 [13] NF849 [15]		
HBS177  [22-51003B] M12x1.50x108mm (x10)	JD411  (31-026592-10) JD410  (31-026593-10)	JN996	 PB852 16x24x1.5mm  PA349 (33-102290-10) 22x16x2mm	HR646  (x2) 24-30670-60/0	 NF851 (x2) 25x40x7mm, FPM/ACM  NF843 50x68x10mm, FPM/ACM (50-305667-70)  NF850 85x105x8mm, FPM (50-319183-00)	NF791 [38] KA625 [13] NF849 [15]		







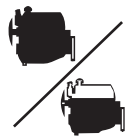



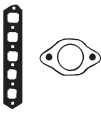

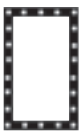

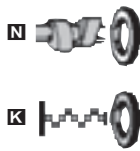

























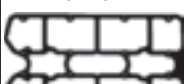
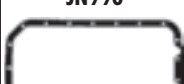





































RENAULT



KW/PS



Clio 1.9L D Diesel		01/91 → 09/98		30		BS520 (Fibre), 1.65mm, 2 Holes (30-026576-10) → 0.868mm		DL961▲ (21-26632-21/0)		EL960 [8] (22-27574-00/0)	
Clio Van 1.9L D Diesel		01/91 → 09/98		30		BS530 (Fibre), 1.75mm, 1 Hole (30-026577-10) → 0.868 → 1.000mm					
F8Q 730/F8Q 732	1870	4	80.00		47-48/ 64-65						
F8Q 678	1870	4	80.00		48-40/ 65-54						
Clio 1.9L D Diesel		09/98 → 05/05		31		AD5030 (Fibre), 1.4mm, 2 Holes (30-029749-00)		DL961▲ (21-26632-21/0)		EC5060 (22-29474-00/0)	
Clio Van 1.9L D Diesel		09/98 →		31		AD5040 (Fibre), 1.50mm, 1 Hole (30-029750-00)					
F8Q 630/F8Q 662	1870	4	80.00		47/64						
						AD5050 (Fibre), 1.60mm, 3 Holes (30-029751-00)					
Clio 1.9L dTi Diesel		02/00 → 05/05		32		AC5070 (Fibre), 1.35mm, 2 Notches (30-029474-00) → 0.653mm		CC5060▲ (21-29483-20/0)		EC5060 (22-29474-00/0)	
F9Q 780	1870	4	80.00		72/98						
						AC5080 (Fibre), 1.45mm, 1 Notch (30-029475-00) → 0.653 → 0.786mm					
						AC5090 (Fibre), 1.55mm, 3 Notches (30-029476-00) → 0.786mm →					
Clio 2.0L 16V Sport		02/00 → 05/05		33		AD5990 (MLS) (30-029781-00)		CD5991		ED5991	
F4R 730	1998	4	82.70	MPi	124/168						
F4R 738	1998	4	82.70	Injection, DOHC	132- 124/ 180- 168						
Clio 2.0L 16V Sport		02/06 →		34		AD5990 (MLS) (30-029781-00)		CD5991		ED5991	
F4R 830	1998	4	82.70	Injection, DOHC	145/197						
Clio 2.0L Williams		01/94 → 09/98		35		BX620 (Fibre), 1.35mm (30-027959-00)		DX620 (21-27959-20/0)		EL960 [8] (22-27574-00/0)	
F7R 700	1998	4	82.70	MPi	108- 110/ 147- 150						
Clio 3.0 V6 Sport (CB1H, CB2S)		12/02 →		36		AH5060 (MLS), 0.74mm		CH5060			
L7X 762	2946	6	87.00	MPi	187/254	AH5070 (MLS), 0.95mm		CH5040			
						AH5040 (MLS), 0.74mm					
						AH5050 (MLS), 0.95mm					
Clio V6 Sport		11/00 → 12/02		37		AH5060 (MLS), 0.74mm		CH5060			
L7X 760	2946	6	87.00	MPi	166/226	AH5070 (MLS), 0.95mm		CH5040			
						AH5040 (MLS), 0.74mm					
						AH5050 (MLS), 0.95mm					
Espace 1.9L dCi Diesel		11/02 →		38		AC5061 (MLS), 1.32mm (30-029473-10)		CC5060▲ (21-29483-20/0)		EC5060 (22-29474-00/0)	
F9Q 680/ F9Q 820/F9Q 826	1870	4	80.00		88/120						











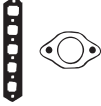

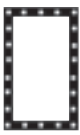

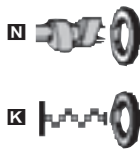





								
HBS244  (22-51103B) M12x1.50x111mm (x10)	JD409 (31-026628-10)	JN732 (50-026632-00)	JJ557 ● PA349 (33-102290-10) 22x16x2mm	HR569  24-30667-00/0	 NF846 25x42x7mm, FPM/ACM (50-319516-00)  NF843 50x68x10mm, FPM/ACM (50-305667-70)  NF850 85x105x8mm, FPM (50-319183-00)	HL5013 [245]  NF791 [38] KA625 [13] NF849 [15]		 AC5070, AC5080, AC5090  AD5030, AD5040, AD5050  BS520, BS530, BS540  BX620  JD409  JD410  JD411  JN732  JN996  JJ557
HBS120  (22-51008B) M12x1.50x118mm (x10)	JD409 (31-026628-10)	JN732 (50-026632-00)	JH5041 ● KG5012 16x23x1.5mm	HR569  24-30667-00/0	 NF846 25x42x7mm, FPM/ACM (50-319516-00)  NA5036 42x54x6mm, FPM (50-319473-00)  NF850 85x105x8mm, FPM (50-319183-00)	HL5017 [245] 		 BX620  JD409  JD410  JD411  JN732  JN996  JJ557
HBS120  (22-51008B) M12x1.50x118mm (x10)	JD5189	JM5086	JH5041 ● KG5012 16x23x1.5mm	HR646  24-30670-60/0	 NF846 25x42x7mm, FPM/ACM (50-319516-00)  NA5036 42x54x6mm, FPM (50-319473-00)  NF850 85x105x8mm, FPM (50-319183-00)	HL5017 [245] 		 JD411  JN732  JN996  JJ557
HBS310  (22-51108B) M12x1.50x117mm (x10)	JD5908  JD5910 	HR397 [57] 34-000410-00	JH5041 ● KG5012 16x23x1.5mm	PA5013 (x16)	 NA5257 28x47x5.5mm  NA5036 42x54x6mm, FPM (50-319473-00)  NF850 85x105x8mm, FPM (50-319183-00)	HL5039 [245] 		 JN996  JJ557
HBS310  (22-51108B) M12x1.50x117mm (x10)	JD5887  (Steel Elastomer) JD5888  (Steel Elastomer) JD5886 		JH5041 ● KG5012 16x23x1.5mm	PA5013 (x16)	 NA5257 28x47x5.5mm  NA5036 42x54x6mm, FPM (50-319473-00)  NF850 85x105x8mm, FPM (50-319183-00)			
HBS177  (22-51003B) M12x1.50x108mm (x10)	JD411  (31-026592-10) JD410  (31-026593-10)	JN996	JJ557 ● PB852 16x24x1.5mm ● PA349 (33-102290-10) 22x16x2mm	HR646  (x2) 24-30670-60/0	 NF846 25x42x7mm, FPM/ACM (50-319516-00)  NF843 50x68x10mm, FPM/ACM (50-305667-70)  NF850 85x105x8mm, FPM (50-319183-00)	HL5013 [245]  KA625 [13] NF849 [15]		
	JD5906  JD5907  (x2) ⊙ JE5069 ⊙ JE5070 ⊙ JE5071							
HBS272  (22-53016B) M10x1.50x147mm (x16)	JD5906  JD5907  (x2) ⊙ JE5069 ⊙ JE5070 ⊙ JE5071				 NA5260 38x50x6mm			
HBS372  (22-51109B) M12x1.50x121mm (x10)	JD5189	JM5086	JH5041 ● KG5012 16x23x1.5mm	HR646  24-30670-60/0	 NF846 25x42x7mm, FPM/ACM (50-319516-00)  NA5036 42x54x6mm, FPM (50-319473-00)  NF850 85x105x8mm, FPM (50-319183-00)	HL5017 [245] 		



KW/PS

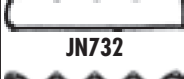

Espace 1.9L dTi Diesel		02/99 → 10/02			39	AC5070 (Fibre), 1.35mm, 2 Notches (30-029474-00) → 0.653mm AC5080 (Fibre), 1.45mm, 1 Notch (30-029475-00) → 0.653 → 0.786mm AC5090 (Fibre), 1.55mm, 3 Notches (30-029476-00) → 0.786mm →	CC5060▲ (21-29483-20/0)	EC5060 (22-29474-00/0)
F9Q 722	1870	4	80.00		72/98			
Espace 2.0L Espace 2.0L 16V		09/01 → 10/02 10/98 → 10/02			40	AD5990 (MLS) (30-029781-00)	CD5991	ED5991
F4R 790/F4R 791	1998	4	82.70	MPi	100/136			
F4R 700/F4R 701	1998	4	82.70	MPi	103/140			
Espace 2.0L		04/05 →			41	AE5110 (MLS) (30-029811-00)	CE5110 (21-29811-20/0)	EE5110 (22-29811-00/0)
F4R 797	1998	4	82.70		120/163			
F4R 897	1998	4	82.70	Injection, DOHC	125/170			
Espace 2.0L		07/84 → 12/90			42	BG170 (Fibre), 1.20mm (30-027064-10)	DG173 (21-27064-20/0)	EG176 [36] (22-24777-01/0)
J6R 734	1995	4	88.00	Carburettor	74/100			
J6R 234	1995	4	88.00	Carburettor	79-81/ 107- 110			
J6R 236	1995	4	88.00	Carburettor	80/108			
Espace 2.0L Espace 2.0L i Espace 2.0L i Quadra		01/91 → 10/96 01/89 → 12/90 03/88 → 12/92			43	BG170 (Fibre), 1.20mm (30-027064-10)	DG173 (21-27064-20/0)	EG176 [36] (22-24777-01/0)
J7R 768	1995	4	88.00	MPi	76/103			
J7R 760	1995	4	88.00	MPi	87-88/ 118- 120			
Espace 2.0L		11/96 → 10/00			44	BX600 (Fibre) (30-027850-00)	DX600 (21-27850-20/0)	EL960 [8] (22-27574-00/0)
F3R 728/ F3R 729/ F3R 742/ F3R 768/F3R 769	1998	4	82.70	MPi	84/114			
Espace 2.0L Turbo		11/02 →			45	AE5110 (MLS) (30-029811-00)	CE5110 (21-29811-20/0)	EE5110 (22-29811-00/0)
F4R 794/ F4R 795/F4R 797	1998	4	82.70		120/163			
Espace 2.1L TD Diesel		10/84 → 10/96			46	BH080 (Fibre), 1.60mm, 1 Hole (30-024772-10) → 0.96mm BG900 (Fibre), 1.70mm (30-024773-10) → 0.96 → 1.04mm BH090 (Fibre), 1.80mm, 2 Holes (30-024774-10) → 1.04mm →	DH080▲ (21-24775-21/0)	EG176 [36] (22-24777-01/0) GH080▲ [36]
J8S 240	2068	4	86.00	SOHC	65/88			
J8S 774	2068	4	86.00		65/88			
J8S 612	2068	4	86.00		66/89			











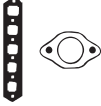

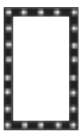











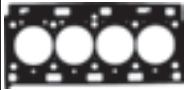











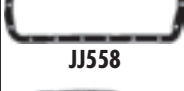





























								
HBS120 ® (22-51008B) M12x1.50x118mm (x10)	JD5189	JM5086	JH5041 ● KG5012 16x23x1.5mm	HR646 ■ 24-30670-60/0	■ NF846 25x42x7mm, FPM/ACM (50-319516-00) ■ NA5036 ■ 42x54x6mm, FPM (50-319473-00) ■ NF850 ■ 85x105x8mm, FPM (50-319183-00)	HL5017 [245]■	 AC5070, AC5080, AC5090  BG170  BG900  BH080, BH090	
HBS310 ® (22-51108B) M12x1.50x117mm (x10)	JD5908 ■ JD5910 ■	HR397 [57] 34-000410-00	JH5041 ● KG5012 16x23x1.5mm	PA5013 (x16)	■ NA5257 28x47x5.5mm ■ NA5036 ■ 42x54x6mm, FPM (50-319473-00) ■ NF850 ■ 85x105x8mm, FPM (50-319183-00)	HL5039 [245]■	 BX600  JB954  JC238	
HBS310 ® (22-51108B) M12x1.50x117mm (x10)	JD5911 ■		JH5041 ● KG5012 16x23x1.5mm	PA5013 (x16)	■ NA5257 28x47x5.5mm ■ NA5036 ■ 42x54x6mm, FPM (50-319473-00) ■ NF850 ■ 85x105x8mm, FPM (50-319183-00)		 JD245  JD419	
HBS116 ® (22-51006B) M12x1.50x243mm (x10)	JB954 ■ ● JC238 (31-025868-10)	JN292 (50-024771-00)	JJ558 (Felt) ● PB852 16x24x1.5mm ● PA349 (33-102290-10) 22x16x2mm	HR569 ■ 24-30667-00/0	■ NA5016 35x47x7mm, FPM/ACM (50-305690-50) ■ NF843 ■ 50x68x10mm, FPM/ACM (50-305667-70) ■ NF844 ■ 90x110x11mm, FPM/ACM	HL5014 [245]■ NF781 (x2) [38] NF849 [15]	 JN292  JN732  JN937	
HBS116 ® (22-51006B) M12x1.50x243mm (x10)	JB954 ■ ● JC238 (31-025868-10)	JN292 (50-024771-00)	JJ558 (Felt) JJ559 (Rubber/Metal) ● PB852 16x24x1.5mm ● PA349 (33-102290-10) 22x16x2mm	HR569 ■ 24-30667-00/0	■ NA5016 35x47x7mm, FPM/ACM (50-305690-50) ■ NF843 ■ 50x68x10mm, FPM/ACM (50-305667-70) ■ NF844 ■ 90x110x11mm, FPM/ACM	HL5014 [245]■ NF781 (x2) [38] NF849 [15]	 JJ557  JJ558	
HBS244 ® (22-51103B) M12x1.50x111mm (x10)	JD419 (31-027573-00)	JN732 (50-026632-00)	JJ557 ● PA349 (33-102290-10) 22x16x2mm	HR569 ■ 24-30667-00/0	■ NF846 25x42x7mm, FPM/ACM (50-319516-00) ■ NF843 ■ 50x68x10mm, FPM/ACM (50-305667-70) ■ NF850 ■ 85x105x8mm, FPM (50-319183-00)	HL5013 [245]■ KA625 [13] NF849 [15]	 JJ559	
HBS310 ® (22-51108B) M12x1.50x117mm (x10)	JD5911 ■ JD5910 ■		JH5041 ● KG5012 16x23x1.5mm	PA5013 (x16)	■ NA5257 28x47x5.5mm ■ NA5036 ■ 42x54x6mm, FPM (50-319473-00) ■ NF850 ■ 85x105x8mm, FPM (50-319183-00)	HL5039 [245]■		
HBS010 ® (22-51104B) M12x1.50x247mm (x2) M12x1.50x148mm (x4) M12x1.50x134mm (x8)	JD245	JN937 (31-028771-00)	JJ558 (Felt) JJ559 (Rubber/Metal) ● PB852 16x24x1.5mm ● PA349 (33-102290-10) 22x16x2mm	HR569 ■ 24-30667-00/0	■ NA5016 35x47x7mm, FPM/ACM (50-305690-50) ■ NF843 ■ 50x68x10mm, FPM/ACM (50-305667-70) ■ NF844 ■ 90x110x11mm, FPM/ACM	HL5014 [245]■ HR351 [37]■ NF781 [2] NF849 [15]		



kWPS



Espace 2.1L TD Diesel		01/91 → 10/96		47	BH080 (Fibre), 1.60mm, 1 Hole (30-024772-10) → 0.96mm BG900 (Fibre), 1.70mm (30-024773-10) → 0.96 → 1.04mm BH090 (Fibre), 1.80mm, 2 Holes (30-024774-10) → 1.04mm →		DH080▲ (21-24775-21/0)	EG176 [36] (22-24777-01/0)
J8S 610/ J8S 772/ J8S 776/J8S 778	2068	4	86.00	65/88				
Espace 2.2L dCi Diesel		07/00 → 10/02		48	AE5210 (MLS), 1.24mm (30-029250-00)		CE5210	EE5220 (22-29037-00/0)
G9T 710	2188	4	87.00	Common Rail	85/115 95-110/ 130- 150			
G9T 742/G9T 743	2188	4	87.00		110/150			
Espace 2.2L		07/86 → 10/96		49	BG170 (Fibre), 1.20mm (30-027064-10)		DG173 (21-27064-20/0)	EG176 [36] (22-24777-01/0)
Espace 2.2L 4x4 Mk II		03/91 → 12/96						
Espace 2.2L Quadra		01/88 → 12/90						
J7T 770/ J7T 772/J7T 776	2165	4	88.00	MPi	79-81/ 107- 110			
J7T 773	2165	4	88.00	MPi	79-81/ 108- 110			
Espace 2.2L 12V TD Diesel		11/96 → 10/00		50	AD5190 (Fibre) (30-029783-00)		CD5190 (21-29783-20/0)	EY070
G8T 714/ G8T 716/G8T 760	2188	4	87.00		83/113			
Espace 2.2L dCi Diesel		02/06 →		51	AE5210 (MLS), 1.24mm (30-029250-00)		CE5210	
G9T 645	2188	4	87.00	Direct Injection, DOHC	102/139			
Espace 2.8L V6		01/91 → 10/96		52	AG5270 (Fibre) ☒		CG5270	
Z7W 712/ Z7W 713/Z7W 717	2849	6	91.00	MPi	110/150			
Espace 3.0L dCi Diesel		11/02 →		53	AG9770 (MLS), 0.60mm, 1 Hole ☒ AG9780 (MLS), 0.65mm, 2 Holes ☒ AG9790 (MLS), 0.70mm, 3 Holes ☒ AG9800 (MLS), 0.60mm, 1 Hole ☒ AG9810 (MLS), 0.65mm, 2 Holes ☒ AG9820 (MLS), 0.70mm, 3 Holes ☒		CG9770▲	EG9770
P9X 701	2958	6	87.50		130/177			
Espace V6 24V		10/98 → 10/02		54	AG9710 (MLS), 1.40mm ☒ AG9720 (MLS), 1.65mm ☒ AG9730 (MLS), 1.40mm ☒ AG9740 (MLS), 1.65mm ☒		CG9720☒ CG9740☒	EG9710
L7X 727	2946	6	87.00	MPi	140/190			
Espace 3.5L V6		11/02 →		55	AE5910 (MLS) ☒ AG6130 (MLS) ☒			EG8230
V4Y 711 V4Y 715	3498 3498	6 6	95.50 95.50	Injection, DOHC, V6	177/240 177/241			
Express Box 1.0L		02/86 → 05/92		56	BH680 (Fibre), 1.20mm (30-024764-10) BM790 (Fibre), 1.75mm [34]		DH683■○ (21-24764-25/0) DH687■ DN684■▲○	EH680 (22-20518-01/0)
	949	4			27/37			











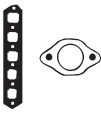

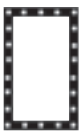

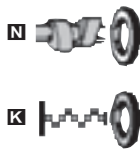

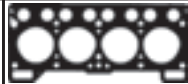









































































								
HBS010   (22-51104B) M12x1.50x247mm (x2) M12x1.50x148mm (x4) M12x1.50x134mm (x8)	JD245	JN937 (31-028771-00)	● PB852 16x24x1.5mm ● PA349 (33-102290-10) 22x16x2mm	HR569  24-30667-00/0	☒ NA5016 35x47x7mm, FPM/ACM (50-305690-50) ☒ NF843  50x68x10mm, FPM/ACM (50-305667-70) ☒ NF844  90x110x11mm, FPM/ACM	HL5014 [245]  HR351 [37]  NF781 (x2) [38] NF849 [15]		 AD5190  AE5210  BG170  BG900  BH080, BH090  BH680, BM790  JB954  JC238  JC669  JD245  JD435  JN292  JN600  JN937  JJ558  JJ562  JJ568
HBS373  (22-51110B) M12x1.50x131mm (x10)	JD5891  JD5892	HM5290 			☒ NA5053 (x2) 30x42x7mm, FPM (50-319488-00) ☒ NF860  93x108x7mm, FPM	HL5035 [245] 		
HBS116  (22-51006B) M12x1.50x243mm (x10)	JB954   JC238 (31-025868-10)	JN292 (50-024771-00)	JJ558 (Felt) JJ562 (Rubber) ● PB852 16x24x1.5mm ● PA349 (33-102290-10) 22x16x2mm	HR569  24-30667-00/0	☒ NA5016 35x47x7mm, FPM/ACM (50-305690-50) ☒ NF843  50x68x10mm, FPM/ACM (50-305667-70) ☒ NF844  90x110x11mm, FPM/ACM	HL5014 [245]  NF781 (x2) [38] NF849 [15]		
HBS119  (22-51010B) M11x1.50x207.5mm (x4) M11x1.50x185mm (x5) M11x1.50x103mm (x4) M11x1.50x185mm (x5)	JD435 	JP006 (50-028939-00)	JJ568 (31-028942-00) ● PA349 (33-102290-10) 22x16x2mm	HR788 	☒ NF858 33x43x6mm, FPM/ACM ☒ NF861  46x59x7mm, FPM ☒ NF860  93x108x7mm, FPM	HL5023 [245] 		
HBS373  (22-51110B) M12x1.50x131mm (x10)					☒ NA5053 30x42x7mm, FPM (50-319488-00)			
HBS127  (22-15009B) M12x1.50x178mm (x16)								
	JD5897  (Steel Elastomer) JD5896   JE5064 (Steel)	HM5292 		HR5094 				
HBS272  (22-53016B) M10x1.50x147mm (x16)	JD5879  JD5880  (Steel Elastomer) JD5878  (MLS)				☒ NA5260 38x50x6mm			
		JM5317 						
HBS104  (22-51005B) M10x1.50x100mm (x10)	JC669 (31-026620-10)	JN600	HC486  ● KJ647 18.3x24x2mm	HR643 	☒ NF834  35x50x8mm, FPM (50-319241-00) ☒ NF835  80x100x8mm, FPM/ACM (50-319239-00)	HR350 [37]  NF791 [38] JR635 [11]		



KWPS



Express Box 1.1L				07/85 → 04/95		57				
C1E 756/ C1E 760/C1E 792	1108	4	70.00	Carburettor		33/45	BH680 (Fibre), 1.20mm (30-024764-10)	DH683 ◻ ○ (21-24764-25/0)	EH680 (22-20518-01/0)	
C1E 750/ C1E 752/C1E 754	1108	4	70.00	Carburettor		33-34/ 45-46	BM790 (Fibre), 1.75mm [34]	DH687 ◻ DN684 ◻ ▲ ○		
C1E 762	1108	4	70.00	Carburettor		33-36/ 45-49				
Express Box 1.2L				09/91 → 03/98		58				
C3G 710/C3G 712	1239	4	74.00	SPi		40/54	BV190 (Fibre), 1.25mm (30-027575-00)	DV190 ▲ (21-27577-20/0)	EV190 [36]	
							BX740 (Fibre), 1.75mm [34]	DX651 (21-27575-20/0)	contains BV190	
Express Box 1.4L				07/85 → 03/98		59				
C1J 780	1397	4	76.00	Carburettor		43/58	BH690 (Fibre), 1.20mm (30-024733-10)	DH693 ◻ ○ DH699 ◻	EH680 (22-20518-01/0)	
C1J 768	1397	4	76.00	Carburettor		43-44/ 58-60	BM800 (Fibre), 1.75mm [34]	DN684 ◻ ▲ ○		
C3J 700/ C3J 702/ C3J 760/C3J 762	1397	4	76.00	SPi		43-44/ 58-60				
C2J 784	1397	4	76.00	Carburettor		44/60				
Express Box 1.4L				09/91 → 03/98		60				
E7J 720/ E7J 724/ E7J 726/E7J 773	1390	4	75.80	SPi		55-59/ 75-80	BX720 (Fibre), 1.35mm (30-026446-10)	DX720 (21-26446-24/0)	ES580 [36]	
E7J 728	1390	4	75.80	SPi		58-59/ 79-80	BX730 (Fibre), 1.75mm [34]			
Express Box 1.6L D Diesel				03/86 → 08/98		61				
F8M 720/ F8M 730/ F8M 736/F8M 760	1595	4	78.00			40/54	BL960 (Fibre), 1.65mm, 2 Holes [33] (30-026968-10) → 03/88 ◻ → 0.885mm BL970 (Fibre), 1.75mm, 1 Hole (30-026969-10) → 03/88 ◻ 0.885 → 0.985mm BL980 (Fibre), 1.85mm, 3 Holes → 03/88 ◻ 0.985mm → BS010 (Fibre), 1.65mm, 2 Holes (30-025301-20) 04/88 → ◻ → 0.885mm BS020 (Fibre), 1.75mm, 1 Hole (30-025302-20) 04/88 → ◻ 0.885 → 0.985mm BS030 (Fibre), 1.85mm, 3 Holes (30-025303-20) 04/88 → ◻ 0.985mm →	DL961 ▲ (21-26632-21/0)	EL960 [8] (22-27574-00/0)	
Express Box 1.9L D Diesel				09/91 → 03/98		62				
F8Q 640	1870	4	80.00			40/54	BS520 (Fibre), 1.65mm, 2 Holes (30-026576-10)	DL961 ▲ (21-26632-21/0)	EL960 [8] (22-27574-00/0)	
F8Q 722/ F8Q 724/ F8Q 774/F8Q 776	1870	4	80.00			47-48/ 64-67	◻ → 0.868mm BS530 (Fibre), 1.75mm, 1 Hole (30-026577-10)			
F8Q 682	1870	4	80.00			48/65	◻ 0.868 → 1.000mm BS540 (Fibre), 1.85mm, 3 Holes (30-026578-10) ◻ 1.000mm →			











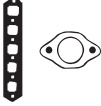

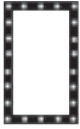

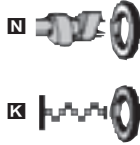

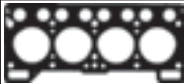

















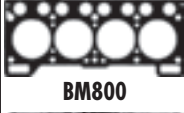





























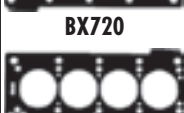

								 BH680, BM790, BH690	 JJ557
HBS104  (22-51005B) M10x1.50x100mm (x10)	JC669 (31-026620-10)	JN600	HC486  ● PA349 (33-102290-10) 22x16x2mm	HR643 	 NF834  35x50x8mm, FPM (50-319241-00)  NF835  80x100x8mm, FPM/ACM (50-319239-00)	HR350 [37]  NF791 [38] LT839 [13] JR635 [11]	 BL960, BL970, BL980	 BM800	
HBS104  (22-51005B) M10x1.50x100mm (x10)	JD231	JN936 (50-027577-00)	HC486  ● PA349 (33-102290-10) 22x16x2mm	HR643 	 NF834  35x50x8mm, FPM (50-319241-00)  NF835  80x100x8mm, FPM/ACM (50-319239-00)	HT025 [37]  NF791 [38] LT839 [13]	 BS010, BS020, BS030	 BS520, BS530, BS540	
HBS104  (22-51005B) M10x1.50x100mm (x10)	JC669 (31-026620-10)	JN600	HC486  ● PA349 (33-102290-10) 22x16x2mm	HR643 	 NF834  35x50x8mm, FPM (50-319241-00)  NF835  80x100x8mm, FPM/ACM (50-319239-00)	HR564 [37]  NF791 [38] LT839 [13]	 BV190, BX740		
HBS102  (22-51001B) M10x1.50x98mm (x5) M10x1.50x113mm (x5)	JC956  JC955  [133]	JN789 (31-026584-00)	JJ407 ● PA349 (33-102290-10) 22x16x2mm	HR646  24-30670-60/0	 NA5053 30x42x7mm, FPM (50-319488-00)  NA5016  35x47x7mm, FPM (50-305690-50)  NF835  80x100x8mm, FPM/ACM (50-319239-00)	HL5015 [245]  HR658 [37] 	 BX720	 BX730	
HBS244  (22-51103B) M12x1.50x111mm (x10)	JD409 (31-026628-10)	JN732 (50-026632-00)	JJ557 ● PA349 (33-102290-10) 22x16x2mm	HR569  24-30667-00/0	 NF846 25x42x7mm, FPM/ACM (50-319516-00)  NF843  50x68x10mm, FPM/ACM (50-305667-70)  NF850  85x105x8mm, FPM (50-319183-00)	HL5013 [245]  NF791 [38] KA625 [13] NF849 [15]	 JC669	 JC955	
HBS244  (22-51103B) M12x1.50x111mm (x10)	JD409 (31-026628-10)	JN732 (50-026632-00)	JJ557 ● PA349 (33-102290-10) 22x16x2mm	HR569  24-30667-00/0	 NF846 25x42x7mm, FPM/ACM (50-319516-00)  NF843  50x68x10mm, FPM/ACM (50-305667-70)  NF850  85x105x8mm, FPM (50-319183-00)	HL5013 [245]  NF791 [38] KA625 [13] NF849 [15]	 JC956	 JD231	
HBS244  (22-51103B) M12x1.50x111mm (x10)	JD409 (31-026628-10)	JN732 (50-026632-00)	JJ557 ● PA349 (33-102290-10) 22x16x2mm	HR569  24-30667-00/0	 NF846 25x42x7mm, FPM/ACM (50-319516-00)  NF843  50x68x10mm, FPM/ACM (50-305667-70)  NF850  85x105x8mm, FPM (50-319183-00)	HL5013 [245]  NF791 [38] KA625 [13] NF849 [15]	 JN600	 JN732	
HBS244  (22-51103B) M12x1.50x111mm (x10)	JD409 (31-026628-10)	JN732 (50-026632-00)	JJ557 ● PA349 (33-102290-10) 22x16x2mm	HR569  24-30667-00/0	 NF846 25x42x7mm, FPM/ACM (50-319516-00)  NF843  50x68x10mm, FPM/ACM (50-305667-70)  NF850  85x105x8mm, FPM (50-319183-00)	HL5013 [245]  NF791 [38] KA625 [13] NF849 [15]	 JN789	 JN936	
							 JJ407		



KW/PS



Extra Van 1.0L		02/86 → 05/92		63		BH680 (Fibre), 1.20mm (30-024764-10) BM790 (Fibre), 1.75mm [34]		DH683 (21-24764-25/0) DH687 DN684		EH680 (22-20518-01/0)	
	949	4			27/37						
Extra Van 1.1L		07/85 → 04/95		64		BH680 (Fibre), 1.20mm (30-024764-10) BM790 (Fibre), 1.75mm [34]		DH683 (21-24764-25/0) DH687 DN684		EH680 (22-20518-01/0)	
C1E 756/ C1E 760/C1E 792	1108	4	70.00	Carburettor	33/45						
C1E 750/ C1E 752/C1E 754	1108	4	70.00	Carburettor	33-34/ 45-46						
C1E 762	1108	4	70.00	Carburettor	33-36/ 45-49						
Extra Van 1.2L		09/91 → 03/98		65		BV190 (Fibre), 1.25mm (30-027575-00) BX740 (Fibre), 1.75mm [34]		DV190 (21-27577-20/0) DX651 (21-27575-20/0) contains BV190		EV190 [36]	
C3G 710/C3G 712	1239	4	74.00	SPi	40/54						
Extra Van 1.4L		07/85 → 03/98		66		BH690 (Fibre), 1.20mm (30-024733-10) BM800 (Fibre), 1.75mm [34]		DH693 DH699 DN684		EH680 (22-20518-01/0)	
C1J 780	1397	4	76.00	Carburettor	43/58						
C1J 768	1397	4	76.00	Carburettor	43-44/ 58-60						
C3J 700/ C3J 702/ C3J 760/C3J 762	1397	4	76.00	SPi	43-44/ 58-60						
C2J 784	1397	4	76.00	Carburettor	44/60						
Extra Van 1.4L		09/91 → 03/98		67		BX720 (Fibre), 1.35mm (30-026446-10) BX730 (Fibre), 1.75mm [34]		DX720 (21-26446-24/0)		ES580 [36]	
E7J 720/ E7J 724/ E7J 726/E7J 773	1390	4	75.80	SPi	55-59/ 75-80						
E7J 728	1390	4	75.80	SPi	58-59/ 79-80						
Extra Van 1.6L D Diesel		03/86 → 08/98		68		BL960 (Fibre), 1.65mm, 2 Holes [33] (30-026968-10) → 03/88 → 0.885mm BL970 (Fibre), 1.75mm, 1 Hole (30-026969-10) → 03/88 0.885 → 0.985mm BL980 (Fibre), 1.85mm, 3 Holes → 03/88 0.985mm → BSO10 (Fibre), 1.65mm, 2 Holes (30-025301-20) 04/88 → → 0.885mm BSO20 (Fibre), 1.75mm, 1 Hole (30-025302-20) 04/88 → 0.885 → 0.985mm BSO30 (Fibre), 1.85mm, 3 Holes (30-025303-20) 04/88 → 0.985mm →		DL961 (21-26632-21/0)		EL960 [8] (22-27574-00/0)	
F8M 720/ F8M 730/ F8M 736/F8M 760	1595	4	78.00		40/54						







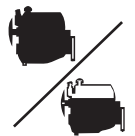



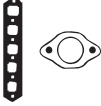

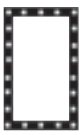

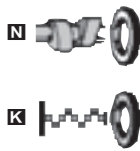



































































								 BH680, BM790, BH690	 JJ557
HBS104  (22-51005B) M10x1.50x100mm (x10)	JC669 (31-026620-10)	JN600	HC486  ● KJ647 18.3x24x2mm	HR643 	 NF834  35x50x8mm, FPM (50-319241-00)  NF835  80x100x8mm, FPM/ACM (50-319239-00)	HR350 [37]  NF791 [38] JR635 [11]	 BL960, BL970, BL980		
HBS104  (22-51005B) M10x1.50x100mm (x10)	JC669 (31-026620-10)	JN600	HC486  ● PA349 (33-102290-10) 22x16x2mm	HR643 	 NF834  35x50x8mm, FPM (50-319241-00)  NF835  80x100x8mm, FPM/ACM (50-319239-00)	HR350 [37]  NF791 [38] LT839 [13] JR635 [11]	 BM800		
HBS104  (22-51005B) M10x1.50x100mm (x10)	JD231	JN936 (50-027577-00)	HC486  ● PA349 (33-102290-10) 22x16x2mm	HR643 	 NF834  35x50x8mm, FPM (50-319241-00)  NF835  80x100x8mm, FPM/ACM (50-319239-00)	HT025 [37]  NF791 [38] LT839 [13]	 BS010, BS020, BS030		
HBS104  (22-51005B) M10x1.50x100mm (x10)	JC669 (31-026620-10)	JN600	HC486  ● PA349 (33-102290-10) 22x16x2mm	HR643 	 NF834  35x50x8mm, FPM (50-319241-00)  NF835  80x100x8mm, FPM/ACM (50-319239-00)	HR564 [37]  NF791 [38] LT839 [13]	 BV190, BX740		
HBS102  (22-51001B) M10x1.50x98mm (x5) M10x1.50x113mm (x5)	JC956  JC955  [133]	JN789 (31-026584-00)	JJ407 ● PA349 (33-102290-10) 22x16x2mm	HR646  24-30670-60/0	 NA5053 30x42x7mm, FPM (50-319488-00)  NA5016  35x47x7mm, FPM (50-305690-50)  NF835  80x100x8mm, FPM/ACM (50-319239-00)	HL5015 [245]  HR658 [37] 	 BX720 BX730		
HBS244  (22-51103B) M12x1.50x111mm (x10)	JD409 (31-026628-10)	JN732 (50-026632-00)	JJ557 ● PA349 (33-102290-10) 22x16x2mm	HR569  24-30667-00/0	 NF846 25x42x7mm, FPM/ACM (50-319516-00)  NF843  50x68x10mm, FPM/ACM (50-305667-70)  NF850  85x105x8mm, FPM (50-319183-00)	HL5013 [245]  NF791 [38] KA625 [13] NF849 [15]	 JC669 JC955 JC956		
							 JD231 JD409		
							 JN600 JN732 JN789		
							 JN936 JJ407		



KW/PS



Extra Van 1.9L D Diesel				09/91 → 03/98		69	BS520 (Fibre), 1.65mm, 2 Holes (30-026576-10) → 0.868mm BS530 (Fibre), 1.75mm, 1 Hole (30-026577-10) → 0.868 → 1.000mm BS540 (Fibre), 1.85mm, 3 Holes (30-026578-10) → 1.000mm →		DL961▲ (21-26632-21/0)	EL960 [8] (22-27574-00/0)
F8Q 640	1870	4	80.00			40/54				
F8Q 722/ F8Q 724/ F8Q 774/F8Q 776 F8Q 682	1870	4	80.00			47-48/ 64-67 48/65				
Fuego Coupe 1.4L TL/GTL				02/80 → 10/85		70	BH690 (Fibre), 1.20mm (30-024733-10) BM800 (Fibre), 1.75mm [34]		DH690■○	EH694 [36] GH691 ○ [36]
847 720	1397	4	76.00	Carburettor		47/64				
Fuego Coupe 1.6L TS/GTS				10/80 → 10/85		71			DF871○	EF870 [36]
843 723/843 724	1647	4	79.00	Carburettor		69-71/ 96-97				
A6M 725/A6M 726	1647	4	79.00	Carburettor		71/96				
Fuego Coupe 1.6L Turbo				08/83 → 10/85		72	BT080 (Fibre), 1.50mm			EF870 [36]
A5L 750	1565	4	77.00	Carburettor		97/132				
Fuego Coupe 2.0L TX/GTX				10/80 → 10/85		73	BG170 (Fibre), 1.20mm (30-027064-10)		DG170	EG176 [36] (22-24777-01/0)
829 710/J6R 710/ J6R 712/J6R 713/ J6R 715/J6R 726	1995	4	88.00	Carburettor		81/110				
Fuego Coupe 2.1L TD Diesel				08/82 → 10/85		74	BH080 (Fibre), 1.60mm, 1 Hole (30-024772-10) → 0.96mm BG900 (Fibre), 1.70mm (30-024773-10) → 0.96 → 1.04mm BH090 (Fibre), 1.80mm, 2 Holes (30-024774-10) → 1.04mm →		DH080▲ (21-24775-21/0)	EG176 [36] (22-24777-01/0) GH080▲ [36]
J8S 712	2068	4	86.00			65/88				
Grand Scénic 1.5L dCi Diesel				04/04 →		75	AE5200 (MLS) (30-029015-00) → 05/04 AG9490 (MLS) (30-029497-00) 05/04 →			EE5200
K9K 728/K9K 729	1461	4	76.00			74/101				
Grand Scénic 1.5L dCi Diesel				05/05 →		76	AG9490 (MLS) (30-029497-00)			EE5200
K9K 729	1461	4	76.00			74/101				
Grand Scénic 1.6L				04/04 →		77	AC5100 (MLS), 1.20mm (30-029743-00)		CC5100 (21-29743-20/0)	
K4M 761/K4M 782	1598	4	79.50	MPi		83/113				

								
HBS244  (22-51103B) M12x1.50x111mm (x10)	JD409 (31-026628-10)	JN732 (50-026632-00)	JJ557 ● PA349 (33-102290-10) 22x16x2mm	HR569  24-30667-00/0	NF846 25x42x7mm, FPM/ACM (50-319516-00) NF843  50x68x10mm, FPM/ACM (50-305667-70) NF850  85x105x8mm, FPM (50-319183-00)	HL5013 [245]  NF791 [38] KA625 [13] NF849 [15]		 AC5100  AE5200  BG170  BG900  BH080, BH090  BH690  BM800  BS520, BS530, BS540  BT080  JB855  JB954  JB997  JC238  JD245  JD409  JN292  JN600  JN697  JN732
HBS104  (22-51005B) M10x1.50x100mm (x10)	JB997	JN600	HC354  ● PA349 (33-102290-10) 22x16x2mm		NF722  35x50x10mm, MVQ NF834  35x50x8mm, FPM (50-319241-00) NF835  80x100x8mm, FPM/ACM (50-319239-00) NF634  80x100x13mm, MVQ (50-319343-00)	HR564 [37]  NF541 (x2) [2]  NF781 (x2) [38] NF545 [42] LT832 [46]		 HC354  JJ557  JJ558
	JB855  (x4) (31-022722-10)		● PA349 (33-102290-10) 22x16x2mm		NF685  45x60x10mm, ACM NF786  45x60x10mm, MVQ NF634  80x100x13mm, MVQ (50-319343-00) NF835  80x100x8mm, FPM/ACM (50-319239-00)	HR565 [37]  NF781 (x2) [38] LT832 [46]		
	JB855  (x4) (31-022722-10)		● PA349 (33-102290-10) 22x16x2mm		NF685  45x60x10mm, ACM NF786  45x60x10mm, MVQ NF835  80x100x8mm, FPM/ACM (50-319239-00) NF634  80x100x13mm, MVQ (50-319343-00)	HR565 [37]  NF781 (x2) [38]		
HBS116  (22-51006B) M12x1.50x243mm (x10)	JB954  ● JC238 (31-025868-10)	JN292 (50-024771-00)	JJ558 (Felt) (Felt) ● PB852 16x24x1.5mm ● PA349 (33-102290-10) 22x16x2mm	HR569  24-30667-00/0	NA5016 35x47x7mm, FPM/ACM (50-305690-50) NF687 35x47x7mm, ACM NF843  50x68x10mm, FPM/ACM (50-305667-70) NF844  90x110x11mm, FPM/ACM	HL5014 [245]  NF781 (x2) [38] NF545 [42] NF849 [15]		
HBS010   (22-51104B) M12x1.50x247mm (x2) M12x1.50x148mm (x4) M12x1.50x134mm (x8)	JD245	JN697 (31-024775-10)	JJ558 (Felt) (Felt) ● PB852 16x24x1.5mm ● PA349 (33-102290-10) 22x16x2mm	HR569  24-30667-00/0	NA5016 35x47x7mm, FPM/ACM (50-305690-50) NF648  50x68x10mm, MVQ (50-306251-00) NF843  50x68x10mm, FPM/ACM (50-305667-70) NF844  90x110x11mm, FPM/ACM	HL5014 [245]  HR351 [37]  NF781 (x2) [38] NF849 [15]		
HBS299  (22-29019B) M11x1.50x125.0mm (x10)	JD5402  (31-030008-00) ● KK5643 (31-030009-00)	JM7054 (NBR)	JH5109 (NBR)	HR817  24-30614-78/0	NA5215 28x42x5mm, FPM NA5255  35x47x7mm	HL5026 [245] 		
HBS299  (22-29019B) M11x1.50x125.0mm (x10)	JD5402  (31-030008-00)	JM7054 (NBR)	JH5109 (NBR)	HR817  24-30614-78/0	NA5215 28x42x5mm, FPM NA5255  35x47x7mm	HL5026 [245] 		
HBS301  (22-51107B) M10x1.50x117mm (x10)	JD5393  JD5894  ● JE5063		JH5108 ● PA349 (33-102290-10) 22x16x2mm		NA5215 (x2) 28x42x5mm, FPM NA5016  35x47x7mm, FPM (50-305690-50) NF835  80x100x8mm, FPM/ACM (50-319239-00)	HL5029 [245] 		



KW/PS

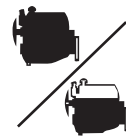

Grand Scénic 1.9L dCi Diesel		04/04 →		78	AC5061 (MLS), 1.32mm (30-029473-10)	CC5060▲ (21-29483-20/0)	EC5060 (22-29474-00/0) EC5061
F9Q 812	1870	4	80.00	Direct Injection, SOHC	88/120		
Grand Scénic 1.9L dCi Diesel		05/05 →		79	AC5061 (MLS), 1.32mm (30-029473-10)	CC5060▲ (21-29483-20/0)	EC5060 (22-29474-00/0)
F9Q 816/F9Q 818	1870	4	80.00		81/110 81-96/ 110- 131		
Grand Scénic 2.0L dCi Diesel		09/05 →		80	AG9760 (MLS)	CG9760	EG9760
M9R 700	1995	4	84.00	Direct Injection, DOHC	110/150		
Grand Scénic 2.0L		04/04 →		81	AD5990 (MLS) (30-029781-00)	CD5991	ED5991
F4R 770/F4R 771	1998	4	82.70	MPi	99/135		
Grand Scénic 2.0L		04/04 →		82	AE5110 (MLS) (30-029811-00)	CE5110 (21-29811-20/0)	EE5110 (22-29811-00/0)
F4R 776	1998	4	82.70	MPi, DOHC	120/163		
Kangoo 1.2L		03/98 →		83	BX630 (Fibre) (30-028934-00)	DX630 (21-28934-20/0)	EA140 (22-28935-00/0)
D7F 744/D7F 746	1149	4	69.00	MPi	43/58		
D7F 710/ D7F 720/ D7F 722/D7F 726	1149	4	69.00	MPi	44/60		
Kangoo 1.2L 16V		06/01 →		84	AD5980 (MLS) (30-029780-00) AG7950 (MLS) D4F-712	CD5981	EG7950 D4F-712
D4F 712/ D4F 714/D4F 716	1149	4	69.00	MPi	55/75		
Kangoo 1.4L		03/98 →		85	BX720 (Fibre), 1.35mm (30-026446-10) E7J BX730 (Fibre), 1.75mm [34] E7J		EA150 E7J
E7J 634/ E7J 635/E7J 780 K7J 701/K7J700	1390	4	75.80	SPi	55/75		
	1390	4	79.50	MPi	55/75		
Kangoo 1.5L dCi Diesel		12/01 →		86	AE5200 (MLS) (30-029015-00) →05/04 AG9490 (MLS) (30-029497-00) 05/04 →	CE5200▲ (21-29015-20/0) →09/03	EE5200
K9K 700/K9K 704 K9K 702/K9K 710	1461	4	76.00 76.00		48/65 60/81		
Kangoo 1.5L dCi Diesel		06/05 →		87	AE5200 (MLS) (30-029015-00) →05/04 AG9490 (MLS) (30-029497-00) 05/04 →		EE5200
K9K 714 K9K 718	1461	4	76.00 76.00	Direct Injection Direct Injection	50/68 62/84		
Kangoo 1.5L dCi Diesel		02/08 →		88	AG9490 (MLS) (30-029497-00)		EE5200
K9K 800 K9K 802 K9K 806 K9K 804	1461	4	76.00 76.00 76.00 76.00	 Direct Injection, SOHC Direct Injection, SOHC Direct Injection, SOHC	63/86 63/86 76/103 78/106		

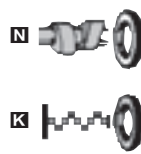
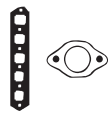

AE5200



BX630



BX720



BX730



JD420



JD421



JN789



JN997



JJ565

HBS372 Ⓢ (22-51109B) M12x1.50x121mm (x10)	JD5189 JD5890 (MLS) Ⓢ JE5061 (MLS) Ⓢ JE5062 (MLS)	JM5086	JH5041 ● KG5012 16x23x1.5mm	HR646 Ⓢ 24-30670-60/0	NA NF846 25x42x7mm, FPM/ACM (50-319516-00) NA NA5036 Ⓢ 42x54x6mm, FPM (50-319473-00) NA NF850 Ⓢ 85x105x8mm, FPM (50-319183-00)	HL5017 [245]Ⓢ
HBS372 Ⓢ (22-51109B) M12x1.50x121mm (x10)	JD5189	JM5086	JH5041 ● KG5012 16x23x1.5mm	HR646 Ⓢ 24-30670-60/0	NA NF846 25x42x7mm, FPM/ACM (50-319516-00) NA NA5036 Ⓢ 42x54x6mm, FPM (50-319473-00) NA NF850 Ⓢ 85x105x8mm, FPM (50-319183-00)	HL5017 [245]Ⓢ
	JD5895 Ⓢ (Steel Elastomer)	HM5291 Ⓢ				
HBS310 Ⓢ (22-51108B) M12x1.50x117mm (x10)	JD5908 Ⓢ JD5910 Ⓢ	HR397 [57] 34-000410-00	JH5041 ● KG5012 16x23x1.5mm	PA5013 (x16)	NA NA5257 28x47x5.5mm NA NA5036 Ⓢ 42x54x6mm, FPM (50-319473-00) NA NF850 Ⓢ 85x105x8mm, FPM (50-319183-00)	HL5039 [245]Ⓢ
HBS310 Ⓢ (22-51108B) M12x1.50x117mm (x10)	JD5911 Ⓢ JD5910 Ⓢ	HR397 [57] 34-000410-00	JH5041 ● KG5012 16x23x1.5mm	PA5013 (x16)	NA NA5257 28x47x5.5mm NA NA5036 Ⓢ 42x54x6mm, FPM (50-319473-00) NA NF850 Ⓢ 85x105x8mm, FPM (50-319183-00)	HL5039 [245]Ⓢ
HBS241 Ⓢ (22-51102B) M9x1.25x103mm (x10)	JD421 Ⓢ JD420 Ⓢ	JN997 →01/00 JM5131 (50-029881-00) 01/00→	JJ565 ● PA349 (33-102290-10) 22x16x2mm	HR789 Ⓢ	NA NA5053 30x42x7mm, FPM (50-319488-00) NA NF856 Ⓢ 32x44x6mm, FPM/ACM	HL5021 [245]Ⓢ NF791 [38]
HBS283 Ⓢ (22-72004B) M9x1.25x122mm (x10)		JM5185 D4F-712			NA NA5261 28x47x8mm, PTFE	HL5036 [245]Ⓢ
HBS102 Ⓢ (22-51001B) M10x1.50x98mm (x5) M10x1.50x113mm (x5) E7J	JD418 Ⓢ [133] E7J	JN789 (31-026584-00) E7J	● PA349 (33-102290-10) 22x16x2mm	HR646 Ⓢ 24-30670-60/0	NA NA5053 30x42x7mm, FPM (50-319488-00) E7J NA NA5016 Ⓢ 35x47x7mm, FPM (50-305690-50) E7J NA NF835 Ⓢ 80x100x8mm, FPM/ACM (50-319239-00) E7J	HL5015 [245]Ⓢ
HBS299 Ⓢ (22-29019B) M11x1.50x125.0mm (x10)	JD5402 Ⓢ (31-030008-00) Ⓢ KK5643 (31-030009-00)	JM7054 (NBR)		HR817 Ⓢ 24-30614-78/0	NA NA5215 28x42x5mm, FPM NA NA5255 Ⓢ 35x47x7mm	HL5026 [245]Ⓢ
HBS299 Ⓢ (22-29019B) M11x1.50x125.0mm (x10)	JD5402 Ⓢ (31-030008-00)	JM7054 (NBR)		HR817 Ⓢ 24-30614-78/0	NA NA5215 28x42x5mm, FPM NA NA5255 Ⓢ 35x47x7mm	
HBS299 Ⓢ (22-29019B) M11x1.50x125.0mm (x10)	JD5402 Ⓢ (31-030008-00)	JM7054 (NBR)		HR817 Ⓢ 24-30614-78/0	NA NA5215 28x42x5mm, FPM	

RENAULT



KWPS

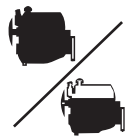

Kangoo 1.6L 16V 06/01 → 89						AC5100 (MLS), 1.20mm (30-029743-00)	CC5100 (21-29743-20/0)	
Kangoo 1.6L 16V 4x4 10/01 →								
K4M 750/K4M 753	1598	4	79.50	MPi	70/95			
K4M 752	1598	4	79.50	MPi	79/81/ 107/ 109			
Kangoo 1.6L 16V bivalent 06/05 → 90						AC5100 (MLS), 1.20mm (30-029743-00)	CC5100 (21-29743-20/0)	
	1598	4			60/82			
Kangoo 1.9L dCi Diesel 07/03 → 91						AC5070 (Fibre), 1.35mm, 2 Notches (30-029474-00)	CC5060▲ (21-29483-20/0)	EC5060 (22-29474-00/0)
Kangoo 1.9L dCi 4x4 Diesel 10/01 →								
Kangoo 1.9L dTi Diesel 02/00 →						→+0.653mm		
F9Q 782/F9Q 790	1870	4	80.00		59/80	AC5080 (Fibre), 1.45mm, 1 Notch (30-029475-00)		
F9Q 780	1870	4	80.00		72/98	→-0.653 →+0.786mm		
						AC5090 (Fibre), 1.55mm, 3 Notches (30-029476-00)		
						→-0.786mm →		
Kangoo D 55 1.9L Diesel 03/98 → 92						AD5030 (Fibre), 1.4mm, 2 Holes (30-029749-00)	DL961▲ (21-26632-21/0)	EC5060 (22-29474-00/0)
Kangoo D 65 1.9L Diesel 03/98 →								
F8Q 630/F8Q 662	1870	4	80.00		47/64	AD5040 (Fibre), 1.50mm, 1 Hole (30-029750-00)		
F8Q 632	1870	4	80.00		47-48/ 64-65			
						AD5050 (Fibre), 1.60mm, 3 Holes (30-029751-00)		
Laguna 1.5L dCi Diesel 10/07 → 93						AG9490 (MLS) (30-029497-00)		EE5200
Laguna 1.5L dCi Grandtour Diesel 10/07 →								
K9K 780	1461	4	76.00	Direct Injection, SOHC	76/103			
Laguna 1.6L 16V 11/97 → 03/01 94						AC5100 (MLS), 1.20mm (30-029743-00)	CC5100 (21-29743-20/0)	
K4M 710	1598	4	79.50	MPi	79/107			
K4M 714	1598	4	79.50	Injection, DOHC	79/107			
K4M 711/ K4M 720/K4M 724	1598	4	79.50	MPi	79/81/ 107/ 109			
Laguna 1.6L 16V 02/05 → 95						AC5100 (MLS), 1.20mm (30-029743-00)	CC5100 (21-29743-20/0)	
K4M 716	1598	4	79.50	Injection, DOHC	82/112			
Laguna 1.8L 11/93 → 03/01 96						BX600 (Fibre) (30-027850-00)	DX600 (21-27850-20/0)	EL960 [8] (22-27574-00/0)
F3P 670/F3P 678	1794	4	82.70	MPi	66/89			
F3P 720/F3P 724	1794	4	82.70	MPi	66-69/ 90-94			
Laguna 1.8L 16V 04/98 → 03/01 97						AD5990 (MLS) (30-029781-00)	CD5991	ED5991
F4P 770/ F4P 771/ F4P 773/ F4P 774/F4P 775	1783	4	82.70	MPi	85-89/ 116- 121			
F4P 760	1783	4	82.70	MPi	88/120			
Laguna 1.8L 16V 03/01 → 98						AD5990 (MLS) (30-029781-00)	CD5991	ED5991
F4P 770/F4P 774	1783	4	82.70	MPi	85-89/ 116- 121			

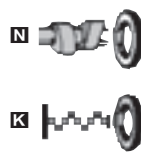
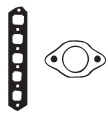

AC5070, AC5080,
AC5090



AC5100



AD5030, AD5040,
AD5050



BX600



JD409



JD419

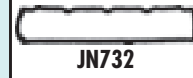

JN732



JJ557



KW/PS



Laguna 1.9L dCi Diesel				09/99 → 03/01	99	AC5061 (MLS), 1.32mm (30-029473-10)	CC5060▲ (21-29483-20/0)	EC5060 (22-29474-00/0)
F9Q 750	1870	4	80.00	Direct Injection, SOHC	55-88/ 75-120			
F9Q 718	1870	4	80.00		72/98			
F9Q 752	1870	4	80.00		74/101			
F9Q 754	1870	4	80.00		74-79/ 101- 107			
F9Q 674	1870	4	80.00		82/112			
F9Q 756	1870	4	80.00	Direct Injection, SOHC	88/120			
F9Q 664	1870	4	80.00					
Laguna 1.9L dCi Diesel				03/01 →	100	AC5061 (MLS), 1.32mm (30-029473-10)	CC5060▲ (21-29483-20/0)	EC5060 (22-29474-00/0)
F9Q 750	1870	4	80.00		55-88/ 75-120			
F9Q 756	1870	4	80.00		88/120			
Laguna 1.9L dCi Diesel				05/05 →	101	AC5061 (MLS), 1.32mm (30-029473-10)	CC5060▲ (21-29483-20/0)	EC5061
F9Q 758/F9Q 759	1870	4	80.00	SOHC	96/130			
Laguna 1.9L dTi Diesel				10/97 → 03/01	102	AC5070 (Fibre), 1.35mm, 2 Notches (30-029474-00) →0.653mm AC5080 (Fibre), 1.45mm, 1 Notch (30-029475-00) →0.653 → 0.786mm AC5090 (Fibre), 1.55mm, 3 Notches (30-029476-00) →0.786mm →	CC5060▲ (21-29483-20/0)	EC5060 (22-29474-00/0)
F9Q 717	1870	4	80.00	Direct Injection, SOHC	72-75/ 98-102			
F9Q 710/F9Q 716	1870	4	80.00		74/100			
Laguna 2.0L				09/99 → 02/01	103	AG9320 (MLS) (30-030286-00)		
Laguna 2.0L 16V				10/07 →				
Laguna 2.0L Mk II				09/02 → 05/05				
F4R 713	1998	4			103/140			
F4R 780	1998	4	82.70	MPi	99/135			
F4R 780	1998	4	82.70	MPi	103/140			
Laguna 2.0L 16V Turbo				10/07 →	104	AG9320 (MLS) (30-030286-00)		
F4R 811	1998	4	82.70	DOHC	125/170			
Laguna 2.0L				11/93 → 03/01	105	BX600 (Fibre) (30-027850-00)	DX600 (21-27850-20/0)	EL960 [8] (22-27574-00/0)
F3R 722/F3R 723	1998	4	82.70	MPi	70/95			
Laguna 2.0L				11/93 → 03/01	106	BX600 (Fibre) (30-027850-00)	DX600 (21-27850-20/0)	EL960 [8] (22-27574-00/0)
	1994	4			70/95			
Laguna 2.0L 16V				03/99 → 03/01	107	AD5990 (MLS) (30-029781-00)	CD5991	
F3R 611	1998	4	82.70	Injection, SOHC	83-85/ 113- 116			

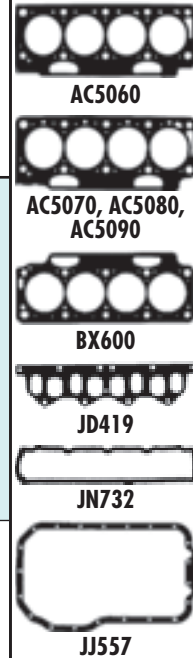
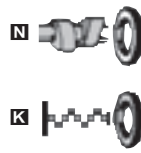
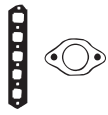

HBS372 Ⓢ (22-51109B) M12x1.50x121mm (x10)	JD5189	JM5086	JH5041 ● KG5012 16x23x1.5mm	HR646 Ⓢ 24-30670-60/0	NF846 25x42x7mm, FPM/ACM (50-319516-00) ☒ NA5036 Ⓢ 42x54x6mm, FPM (50-319473-00) ☒ NF850 Ⓢ 85x105x8mm, FPM (50-319183-00)	HL5017 [245]Ⓢ
HBS372 Ⓢ (22-51109B) M12x1.50x121mm (x10)	JD5189	JM5086	JH5041 ● KG5012 16x23x1.5mm	HR646 Ⓢ 24-30670-60/0	NF846 25x42x7mm, FPM/ACM (50-319516-00) ☒ NA5036 Ⓢ 42x54x6mm, FPM (50-319473-00) ☒ NF850 Ⓢ 85x105x8mm, FPM (50-319183-00)	HL5017 [245]Ⓢ
HBS372 Ⓢ (22-51109B) M12x1.50x121mm (x10)	JD5189 JD5890 (MLS) ☉ JE5061 (MLS) ☉ JE5062 (MLS)	JM5086	JH5041 ● KG5012 16x23x1.5mm	HR646 Ⓢ 24-30670-60/0	NF846 25x42x7mm, FPM/ACM (50-319516-00) ☒ NA5036 Ⓢ 42x54x6mm, FPM (50-319473-00) ☒ NF850 Ⓢ 85x105x8mm, FPM (50-319183-00)	HL5017 [245]Ⓢ
HBS120 Ⓢ (22-51008B) M12x1.50x118mm (x10)	JD5189	JM5086	JH5041 ● KG5012 16x23x1.5mm	HR646 Ⓢ 24-30670-60/0	NF846 25x42x7mm, FPM/ACM (50-319516-00) ☒ NA5036 Ⓢ 42x54x6mm, FPM (50-319473-00) ☒ NF850 Ⓢ 85x105x8mm, FPM (50-319183-00)	HL5017 [245]Ⓢ
	JD5908 Ⓢ JD5910 Ⓢ				NA5257 28x47x5.5mm	
					NA5257 28x47x5.5mm	
HBS244 Ⓢ (22-51103B) M12x1.50x111mm (x10)	JD419 (31-027573-00)	JN732 (50-026632-00)	JJ557 ● PA349 (33-102290-10) 22x16x2mm	HR569 Ⓢ 24-30667-00/0	NF846 25x42x7mm, FPM/ACM (50-319516-00) NF847 22x45x7mm, FPM/ACM ☒ NF843 Ⓢ 50x68x10mm, FPM/ACM (50-305667-70) ☒ NF850 Ⓢ 85x105x8mm, FPM (50-319183-00)	HL5013 [245]Ⓢ KA625 [13] NF849 [15]
HBS244 Ⓢ (22-51103B) M12x1.50x111mm (x10)	JD419 (31-027573-00)	JN732 (50-026632-00)	JJ557 ● PA349 (33-102290-10) 22x16x2mm	HR569 Ⓢ 24-30667-00/0	NF846 25x42x7mm, FPM/ACM (50-319516-00) ☒ NF843 Ⓢ 50x68x10mm, FPM/ACM (50-305667-70) ☒ NF850 Ⓢ 85x105x8mm, FPM (50-319183-00)	HL5013 [245]Ⓢ KA625 [13] NF849 [15]
HBS310 Ⓢ (22-51108B) M12x1.50x117mm (x10)			JH5041 ● KG5012 16x23x1.5mm	PA5013 (x16)	☒ NA5036 Ⓢ 42x54x6mm, FPM (50-319473-00) ☒ NF850 Ⓢ 85x105x8mm, FPM (50-319183-00)	



KW/PS



Laguna 2.0L 16V		09/99 → 03/01		108		AD5990 (MLS) (30-029781-00)		CD5991		ED5991	
F4R 712/ F4R 713/ F4R 714/F4R 715 F4R 780	1998	4	82.70	MPi	99/135						
	1998	4	82.70	MPi	103/140						
Laguna 2.0L 16V		01/05 →		109		AE5110 (MLS) (30-029811-00)		CE5110 (21-29811-20/0)		EE5110 (22-29811-00/0)	
F4R 786/F4R 787 F4R 784	1998	4	82.70	MPi	120/163						
	1998	4	82.70	Injection, DOHC	125/170						
Laguna 2.0L 16V		01/05 →		110		AD5990 (MLS) (30-029781-00)		CD5991			
F4R 886/F4R 887	1998	4	82.70	Injection, DOHC	150/204						
Laguna 2.0L 16V		06/95 → 03/01		111		BX650 (Fibre) (30-027376-10)		DX652 (21-27376-21/0)		EA5620 (22-27376-00/0)	
N7Q 700/N7Q 704	1948	4	83.00	MPi	102/139						
Laguna 2.0L 16V IDE		04/01 →		112		AG5420 (MLS)		CG5420		ED5991	
F5R 700	1998	4	86.00	Injection	103/140						
Laguna 2.0L 16V Turbo		01/03 →		113		AE5110 (MLS) (30-029811-00)		CE5110 (21-29811-20/0)		EE5110 (22-29811-00/0)	
F4R 764/F4R 765 F4R 786/F4R 787	1998	4	82.70		120/163						
	1998	4	82.70	MPi	120/163						
Laguna 2.2L D 12V Diesel		11/93 → 03/01		114		BY070 (Fibre) (30-027171-10) →11/95 BY080 (Fibre) (30-028943-00) 11/95 →		DY070▲ (21-28939-20/0)		EY070	
G8T 706/ G8T 752/ G8T 790/G8T 794	2188	4	87.00		61/82						
Laguna 2.2L dCi Diesel		10/01 →		115		AE5210 (MLS), 1.24mm (30-029250-00)		CE5210		EE5220 (22-29037-00/0)	
G9T 702	2188	4	87.00	Common Rail	95-110/ 130- 150						
G9T 700	2188	4	87.00	Direct Injection, DOHC	110/150						
Laguna 2.2L dCi Diesel		05/05 →		116		AE5210 (MLS), 1.24mm (30-029250-00)		CE5210		EE5220 (22-29037-00/0)	
Laguna 2.2L dCi Mk II Diesel		04/04 → 10/05									
G9T 600	2188	4	87.00	Direct Injection, DOHC							
Laguna 2.2L dT Diesel		03/96 → 03/01		117		AD5190 (Fibre) (30-029783-00)		CD5190 (21-29783-20/0)		EY070	
G8T 760	2188	4	87.00		83/113						
Laguna 3.0L 24V		03/97 → 03/01		118		AG9710 (MLS), 1.40mm AG9720 (MLS), 1.65mm AG9730 (MLS), 1.40mm AG9740 (MLS), 1.65mm		CG9720 CG9740		EG9710	
L7X 700/L7X 701	2946	6	87.00	MPi, V6	140/190						

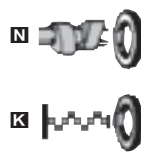
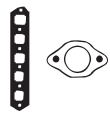

HBS310 ⊕ (22-51108B) M12x1.50x117mm (x10)	JD5908 ■ JD5910 ■	HR397 [57] 34-000410-00	JH5041 ● KG5012 16x23x1.5mm	PA5013 (x16)	■ NA5257 28x47x5.5mm ■ NA5036 ■ 42x54x6mm, FPM (50-319473-00) ■ NF850 ■ 85x105x8mm, FPM (50-319183-00)	HL5039 [245]■
HBS310 ⊕ (22-51108B) M12x1.50x117mm (x10)	JD5911 ■ JD5910 ■ ⊕ JE5060 (Steel)		JH5041 ● KG5012 16x23x1.5mm	PA5013 (x16)	■ NA5257 28x47x5.5mm ■ NA5036 ■ 42x54x6mm, FPM (50-319473-00) ■ NF850 ■ 85x105x8mm, FPM (50-319183-00)	
HBS310 ⊕ (22-51108B) M12x1.50x117mm (x10)			JH5041 ● KG5012 16x23x1.5mm	PA5013 (x16)	■ NA5257 28x47x5.5mm ■ NA5036 ■ 42x54x6mm, FPM (50-319473-00) ■ NF850 ■ 85x105x8mm, FPM (50-319183-00)	
HBS178 ⊕ (22-51009B) M12x1.75x157mm (x10)	JA5039 ■ (31-029601-00) JA5040 ■ (31-028657-00)		● KJ647 18.3x24x2mm	HR5060 ■ (24-30676-75/0)	■ NA5136 30x47x7mm, NBR (50-319470-00) ■ NA5138 44.5x57.2x6.75mm, FPM (50-319352-00) ■ NA5018 ■ 35x47x5.6mm, FPM ■ NA5017 ■ 98x110x8.5mm, FPM (50-319354-00)	
HBS431 (22-51111B)	JD5889 ■ (Steel Elastomer)	HR397 [57] 34-000410-00	JH5041 ● KG5012 16x23x1.5mm	PA5013 (x16)	■ NA5257 28x47x5.5mm ■ NA5036 ■ 42x54x6mm, FPM (50-319473-00) ■ NF850 ■ 85x105x8mm, FPM (50-319183-00)	HL5039 [245]■
HBS310 ⊕ (22-51108B) M12x1.50x117mm (x10)	JD5911 ■ JD5910 ■	HR397 [57] 34-000410-00	JH5041 ● KG5012 16x23x1.5mm	PA5013 (x16)	■ NA5257 28x47x5.5mm ■ NA5036 ■ 42x54x6mm, FPM (50-319473-00) ■ NF850 ■ 85x105x8mm, FPM (50-319183-00)	HL5039 [245]■
HBS119 ⊕ ⊕ (22-51010B) M11x1.50x207.5mm (x4) M11x1.50x185mm (x5) M11x1.50x103mm (x4) M11x1.50x185mm (x5)	JD5782 ■ →11/95 JD436 ■ (31-028940-00) 11/95→ JD435 ■	JP006 (50-028939-00)	JJ568 (31-028942-00) ● PA349 (33-102290-10) 22x16x2mm	HR788 ■	■ NF858 33x43x6mm, FPM/ACM ■ NF859 33x44x7mm, FPM/ACM ■ NF861 ■ 46x59x7mm, FPM ■ NF860 ■ 93x108x7mm, FPM	HL5023 [245]■
HBS373 ⊕ (22-51110B) M12x1.50x131mm (x10)	JD5891 ■ JD5892	HM5290 ■			■ NA5053 (x2) 30x42x7mm, FPM (50-319488-00) ■ NF860 ■ 93x108x7mm, FPM	HL5035 [245]■
HBS373 ⊕ (22-51110B) M12x1.50x131mm (x10)	JD5891 ■ JD5892 JD5912 ■ (MLS)	HM5290 ■			■ NA5053 30x42x7mm, FPM (50-319488-00)	
HBS119 ⊕ ⊕ (22-51010B) M11x1.50x207.5mm (x4) M11x1.50x185mm (x5) M11x1.50x103mm (x4) M11x1.50x185mm (x5)	JD435 ■	JP006 (50-028939-00)	JJ568 (31-028942-00) ● PA349 (33-102290-10) 22x16x2mm	HR788 ■	■ NF858 33x43x6mm, FPM/ACM ■ NF861 ■ 46x59x7mm, FPM ■ NF860 ■ 93x108x7mm, FPM	HL5023 [245]■
HBS272 ⊕ (22-53016B) M10x1.50x147mm (x16)	JD5879 ■ JD5880 ■ (Steel Elastomer) JD5878 ■ (MLS)				■ NA5260 38x50x6mm	



AD5190



AE5210



BX650



BY070



BY080



JA5039



JA5040



JD435



JD436



JJ568











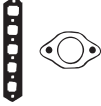

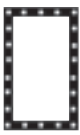

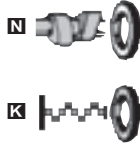



















































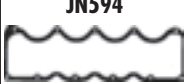

















RENAULT



KW/PS



Model					Year	Power	Part	Part	Part
Laguna 3.0L V6 24V					03/01 →	119	AH5060 (MLS), 0.74mm	CH5060	
L7X 731	2946	6	87.00	MPi	152/207	AH5070 (MLS), 0.95mm	CH5040		
						AH5040 (MLS), 0.74mm			
						AH5050 (MLS), 0.95mm			
Logan 1.5L dCi Diesel					04/07 →	120	AG9490 (MLS)		EE5200
K9K 792	1461	4	76.00		50/68	(30-029497-00)			
Master 1.9L dCi 80 Diesel					11/01 →	121	AC5061 (MLS), 1.32mm	CC5060	EC5060
F9Q 772	1870	4	80.00		60/81	(30-029473-10)	(21-29483-20/0)	(22-29474-00/0)	
Master 1.9L dTi Diesel					09/00 →	122	AC5070 (Fibre), 1.35mm, 2 Notches	CC5060	EC5060
F9Q 770	1870	4	80.00		59/80	(30-029474-00)	(21-29483-20/0)	(22-29474-00/0)	
						→ 0.653mm			
						AC5080 (Fibre), 1.45mm, 1 Notch			
						(30-029475-00)			
						→ 0.653 → 0.786mm			
						AC5090 (Fibre), 1.55mm, 3 Notches			
						(30-029476-00)			
						→ 0.786mm →			
Master 28-35 2.0L					08/80 → 07/98	123	BG170 (Fibre), 1.20mm	DG173	EG176 [36]
J5R 718	1995	4	88.00	Carburettor	57-60/ 78-82	(30-027064-10)	(21-27064-20/0)	(22-24777-01/0)	
J5R 728	1995	4	88.00	Carburettor	58/79				
829 730/829 731	1995	4	88.00	Carburettor	81/110				
Master 28-35 2.1 D Diesel					08/80 → 07/98	124	BH080 (Fibre), 1.60mm, 1 Hole	DH080	EG176 [36]
J8S 330	2068	4	86.00		44/60	(30-024772-10)	(21-24775-21/0)	(22-24777-01/0)	GH080 [36]
						→ 0.96mm			
						BG900 (Fibre), 1.70mm			
						(30-024773-10)			
						→ 0.96 → 1.04mm			
						BH090 (Fibre), 1.80mm, 2 Holes			
						(30-024774-10)			
						→ 1.04mm →			
Master 2.2L					08/80 → 07/98	125	BG170 (Fibre), 1.20mm	DG173	EG176 [36]
J7T 788	2165	4	88.00	MPi	67/91	(30-027064-10)	(21-27064-20/0)	(22-24777-01/0)	
J7T 782	2165	4	88.00	MPi	67-69/ 91-94				
Master 2.2L dCi 90 Diesel					09/00 →	126	AE5210 (MLS), 1.24mm	CE5210	EE5220
G9T 722	2188	4	87.00	Common Rail	66/89	(30-029250-00)		(22-29037-00/0)	
Master 28-35 2.4L D Diesel					08/80 → 08/89	127	BE580 (Fibre), 1.35mm	DE588 [109]	FY291 [110]
8140.61.2300/S8U 731	2445	4	93.00		52/71	(30-024116-10)	(21-26037-23/0)	(20-27426-00/0)	
Master 2.5L dCi 100 Diesel					10/03 →	128	AE5220 (MLS)		EE5220
G9U 754	2463	4	89.00	Direct Injection	73/99	(30-029037-00)		(22-29037-00/0)	
G9U 720	2463	4	89.00		85/115				











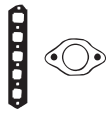

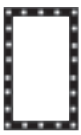

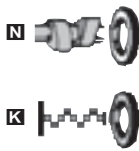









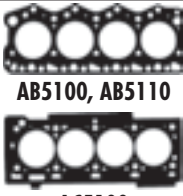

























































															
HBS272  (22-53016B) M10x1.50x147mm (x16)	JD5906  JD5907  (x2)  JE5069  JE5070  JE5071					NA5260 38x50x6mm							 AC5070, AC5080, AC5090	 AE5210	 AE5220
		JM7054 (NBR)											 BE580	 BG170	 BG900
HBS372  (22-51109B) M12x1.50x121mm (x10)	JD5189	JM5086	JH5041  KG5012 16x23x1.5mm	HR646  24-30670-60/0	NF846 25x42x7mm, FPM/ACM (50-319516-00) NA5036  42x54x6mm, FPM (50-319473-00) NF850  85x105x8mm, FPM (50-319183-00)		HL5017 [245] 						 BH080, BH090	 JB954	 JC054
HBS120  (22-51008B) M12x1.50x118mm (x10)	JD5189	JM5086	JH5041  KG5012 16x23x1.5mm	HR646  24-30670-60/0	NF846 25x42x7mm, FPM/ACM (50-319516-00) NA5036  [215] 42x54x6mm, FPM (50-319473-00) NF850  85x105x8mm, FPM (50-319183-00)		HL5017 [245] 						 JB954	 JC055	 JD245
HBS116  (22-51006B) M12x1.50x243mm (x10)	JB954 	JN292 (50-024771-00)	JJ558 (Felt)  PB852 16x24x1.5mm  PA349 (33-102290-10) 22x16x2mm	HR569  24-30667-00/0	NA5016 35x47x7mm, FPM/ACM (50-305690-50) NF843  50x68x10mm, FPM/ACM (50-305667-70) NF844  90x110x11mm, FPM/ACM		HL5014 [245]  NF849 [15]						 JD245	 JN292	 JN462
HBS010   (22-51104B) M12x1.50x247mm (x2) M12x1.50x148mm (x4) M12x1.50x134mm (x8)	JD245	JN697 (31-024775-10)	JJ558 (Felt)  PB852 16x24x1.5mm  PA349 (33-102290-10) 22x16x2mm	HR569  24-30667-00/0	NA5016 35x47x7mm, FPM/ACM (50-305690-50) NF843  50x68x10mm, FPM/ACM (50-305667-70) NF844  90x110x11mm, FPM/ACM		HL5014 [245]  HR351 [37]  NF849 [15]						 JN292	 JN462	 JN594
HBS116  (22-51006B) M12x1.50x243mm (x10)	JB954 	JN292 (50-024771-00)	JJ558 (Felt)  PB852 16x24x1.5mm  PA349 (33-102290-10) 22x16x2mm	HR569  24-30667-00/0	NA5016 35x47x7mm, FPM/ACM (50-305690-50) NF843  50x68x10mm, FPM/ACM (50-305667-70) NF844  90x110x11mm, FPM/ACM		HL5014 [245]  NF849 [15]						 JN697	 JJ100	 JJ519
HBS373  (22-51110B) M12x1.50x131mm (x10)	JD5891  JD5892	HM5290 			NA5053 (x2) 30x42x7mm, FPM (50-319488-00) NF860  93x108x7mm, FPM		HL5035 [245] 						 JJ100	 JJ519	 JJ558
HBS011  (22-51004B) M12x1.25x160mm (x10) M12x1.25x119mm (x12)	JC054  (31-024274-10) JC055  (31-025031-10)	JN462 (50-024272-00) →Eng.574478 JN594 [71] (50-026037-00) Eng.574479→	JJ100 JJ519 (31-025623-00)	HR602  24-30670-61/0 HR782 	NP067 50x70x10mm, FPM (50-307111-70) NP068 55x70x8mm, FPM (50-303186-00) NP067 50x70x10mm, FPM (50-307111-70)		JR580 [11]						 JJ558		
HBS373  (22-51110B) M12x1.50x131mm (x10)															



KWPS



Master 28-35 2.5L D Diesel		08/89 → 07/98		129	AY290 (Fibre), 1.60mm [112] (30-027426-00) AY300 (Fibre), 1.70mm [112] (30-026654-20) AY310 (Fibre), 1.80mm [112] (30-026655-20)	DE588▲ [109] (21-26037-23/0)	FY291▲ [12] (20-27426-00/0)
8140.67.2510/S8U 742	2499	4	93.00	55/75			
Master 28-35 2.5L D Diesel		09/80 → 07/98		130	BE580 (Fibre), 1.35mm (30-024116-10)	DE588▲ [109] (21-26037-23/0)	FY291▲ [110] (20-27426-00/0)
8140.61.2300/S8U 731	2445	4	93.00	52/71			
Master 28-35 2.5L TD Diesel		08/89 → 07/98		131	AB5100 (Fibre), 1.20mm [112] (30-027140-10) BR070 (Fibre), 1.20mm (30-025645-10) AY580 (Fibre), 1.30mm [112] (30-027141-10) AY590 (Fibre), 1.40mm [112] (30-027892-10) AB5110 (Fibre), 1.50mm (30-027147-10)	DS381▲ [111] (21-27141-20/0) Eng.1050634→	FB5100▲ [12] (20-27140-00/0)
Master 35 2.5L TD Diesel		08/89 → 07/98					
8140.27.2500	2499	4	93.00	69/93	Indirect Injection		
8140.27.2510/S9U 714	2499	4	93.00	69/93			
8140.27.2580/S9U 702	2499	4	93.00	72/98			
Master 2.8L dTi Diesel		07/98 → 10/01		132	BX390 (Fibre), 1.20mm [71] (30-027867-00) BX400 (Fibre), 1.30mm [71] (30-027868-00) BX410 (Fibre), 1.40mm [71] (30-027883-00) BX420 (Fibre), 1.50mm [71] (30-027884-00)	DX391▲ (21-27867-21/0)	GX410▲ (20-27867-03/0)
S9W 702	2799	4	94.40	84/114			
Master 2.8L TD Diesel		09/96 →		133	BX420 (Fibre), 1.50mm [71] (30-027884-00)	DX391▲ (21-27867-21/0)	GX410▲ (20-27867-03/0)
8140.23.2565	2800	4	94.40	78/106	Sofim, Turbo		
8140.23.2585	2800	4	94.40	90/122	Sofim, Direct Injection, Turbo Intercooled, Euro 2		
8140.23.2585 (S(WA7)/	2800	4	94.40	90/122	Sofim, Turbo Intercooled		
8140.23.3700							
8140.43.2585	2800	4	94.40	90/122	Sofim, Turbo Intercooled, Euro 2		
8140.43.3700/ 8140.43.3900	2800	4	94.40	90/122	Sofim, Turbo Intercooled		
Megane 1.4L		09/03 →		134	AC5100 (MLS), 1.20mm (30-029743-00)	CC5100 (21-29743-20/0)	
K4J 732	1390	4	79.50	60/82	Injection, DOHC		
Megane 1.4L		09/03 →		135	AC5100 (MLS), 1.20mm (30-029743-00)	CC5100 (21-29743-20/0)	
K4J 730	1390	4	79.50	72/98	MPi		
Megane 1.4L		09/03 →		136	AC5100 (MLS), 1.20mm (30-029743-00)	CC5100 (21-29743-20/0)	
Megane 1.4L 16V		03/99 →					
Megane Cabriolet 1.4L 16V		03/99 →					
K4J 732	1390	4	79.50	60/82	Injection, DOHC		
K4J 714/K4J 750	1390	4	79.50	70/95	MPi		
K4J 730	1390	4	79.50	72/98	MPi		

								
HBS011  (22-51004B) M12x1.25x160mm (x10) M12x1.25x119mm (x12)	JC054  (31-024274-10) JC055E  (31-025031-10)	JN462  (50-024272-00) →Eng.574478 JN594 [71] (50-026037-00) Eng.574479 →	JJ100	HR602  24-30670-61/0	NP067 50x70x10mm, FPM (50-307111-70) NP068 55x70x8mm, FPM (50-303186-00) NP067 50x70x10mm, FPM (50-307111-70) NF885  [3] 70x159x16mm, FPM (50-307266-70) NF883  [3] 114x171x13mm, FPM (50-307265-70)	HL5032 [245]  HJ271 [39]  JR580 [11] LC280 [11] LC281 [11] LC282 [11] KK5599 [45] KV927 [46]	 AB5100, AB5110  AC5100  AY290, AY300, AY310  BE580  BR070, AY580, AY590	
HBS011  (22-51004B) M12x1.25x160mm (x10) M12x1.25x119mm (x12)	JC054  (31-024274-10) JC055E  (31-025031-10)	JN462  (50-024272-00) →Eng.574478 JN594 [71] (50-026037-00) Eng.574479 →	JJ100 JJ519  (31-025623-00)	HR602  24-30670-61/0 HR782 	NP067 50x70x10mm, FPM (50-307111-70) NP068 55x70x8mm, FPM (50-303186-00) NP067 50x70x10mm, FPM (50-307111-70)	JR580 [11]	 BR070, AY580, AY590  BX390, BX400, BX410, BX420	
HBS011  (22-51004B) M12x1.25x160mm (x10) M12x1.25x119mm (x12)	JC054  (31-024274-10) JC055E  (31-025031-10)  JF123 (31-027523-00)	JN594 [71] (50-026037-00) Eng.574799 →	JJ519  (31-025623-00) LS856  (50-025627-00) LS857  (50-025628-00)	HR602  24-30670-61/0 HR781 	NP067 50x70x10mm, FPM (50-307111-70) NP068  55x70x8mm, FPM (50-303186-00) NF853  100x118x10mm, FPM (50-307096-70)	HJ271 [39]  KD929 [72][73] KV927 [46]	 JC054  JC055  JF123	
HBS011  (22-51004B) M12x1.25x160mm (x10) M12x1.25x119mm (x12)	JC054  (31-024274-10) JC055E  (31-025031-10)	JN956		HR602  24-30670-61/0	NP067 50x70x10mm, FPM (50-307111-70) NF885  [3] 70x159x16mm, FPM (50-307266-70) NF883  [3] 114x171x13mm, FPM (50-307265-70)	KD929 [72][73] KD931 [72][73] KD932 [72][73] KK5599 [45] KV927 [46]	 JN462  JN594  JN956	
HBS011  (22-51004B) M12x1.25x160mm (x10) M12x1.25x119mm (x12)	JC054  (31-024274-10) JC055E  (31-025031-10)	JN956		HR602  24-30670-61/0	NP067 50x70x10mm, FPM (50-307111-70) NF885  [3] 70x159x16mm, FPM (50-307266-70) NF883  [3] 114x171x13mm, FPM (50-307265-70)	KD929 [72][73] KD931 [72][73] KD932 [72][73] KK5599 [45] KV927 [46]	 JJ100  JJ519  LS856  LS857	
HBS301  (22-51107B) M10x1.50x117mm (x10)	JD5393  JD5893  (FPM) JD5394E 		JH5108	PA5013 (x16)	NA5215 28x42x5mm, FPM NA5016E  35x47x7mm, FPM (50-305690-50) NF835  80x100x8mm, FPM/ACM (50-319239-00)	HL5029 [245] 		
HBS301  (22-51107B) M10x1.50x117mm (x10)	JD5393  JD5394E 	HR397 [57] 34-000410-00	JH5108	PA5013 (x16)	NA5215 28x42x5mm, FPM NA5016E  35x47x7mm, FPM (50-305690-50) NF835  80x100x8mm, FPM/ACM (50-319239-00)	HL5029 [245] 		
HBS301  (22-51107B) M10x1.50x117mm (x10)	JD5393  JD5893  (FPM) JD5394E 	HR397 [57] 34-000410-00	JH5108	PA5013 (x16)	NA5215 28x42x5mm, FPM NA5016E  35x47x7mm, FPM (50-305690-50) NF835  80x100x8mm, FPM/ACM (50-319239-00)	HL5029 [245] 		

RENAULT



KW/PS



Megane 1.4L 09/96 → 137						BX720 (Fibre), 1.35mm (30-026446-10)	DX721 (21-26446-23/0) →02/97 DX722 03/97→	EA150
Megane 1.4L e 01/96 →								
Megane 1.4L Eco 01/96 →03/99								
E7J 624	1390	4	75.80	SPi	52/71	BX730 (Fibre), 1.75mm [34]	DX722 03/97→	EA150
E7J 626/E7J 764	1390	4	75.80	SPi	55/75			
Megane 1.4L e 03/99 → 138						BX720 (Fibre), 1.35mm (30-026446-10)	DX722	EA150
Megane Scenic 1.4L i 01/97 →09/99								
E7J 626/E7J 764	1390	4	75.80	SPi	55/75	BX730 (Fibre), 1.75mm [34]		
Megane 1.5L dCi Diesel 11/02 → 139						AE5200 (MLS) (30-029015-00) →05/04 AG9490 (MLS) (30-029497-00) 05/04→	CE5200▲ (21-29015-20/0) →09/03	EE5200
K9K 722	1461	4	76.00		60/81			
Megane 1.5L dCi Diesel 10/03 → 140						AE5200 (MLS) (30-029015-00) →05/04 AG9490 (MLS) (30-029497-00) 05/04→		EE5200
K9K 728	1461	4	76.00		74/101			
Megane 1.5L dCi Diesel 09/03 → 141						AE5200 (MLS) (30-029015-00) →05/04 AG9490 (MLS) (30-029497-00) 05/04→		EE5200
K9K 722	1461	4	76.00		60/81			
Megane 1.5L dCi Diesel 09/03 → 142						AE5200 (MLS) (30-029015-00) →05/04 AG9490 (MLS) (30-029497-00) 05/04→		EE5200
K9K 722	1461	4	76.00		60/81			
Megane 1.5L dCi Diesel 02/04 → 143						AE5200 (MLS) (30-029015-00) →05/04 AG9490 (MLS) (30-029497-00) 05/04→		EE5200
K9K 728/K9K 729	1461	4	76.00		74/101			
Megane 1.5L dCi Diesel 05/05 → 144						AG9490 (MLS) (30-029497-00)		EE5200
K9K 724	1461	4	76.00	Direct Injection, SOHC	63/86			
K9K 729	1461	4	76.00		74/101			
Megane 1.5L dCi Diesel 05/05 → 145						AG9490 (MLS) (30-029497-00)		EE5200
K9K 732	1461	4	76.00	Direct Injection, SOHC	78/106			
K9K 734	1461	4	76.00		78/106			
Megane 1.6L 16V 01/07 → 146						AC5100 (MLS), 1.20mm (30-029743-00)	CC5100 (21-29743-20/0)	
K4M 760	1598	4	79.50	MPi	79/81/ 107/ 109			
K4M 761	1598	4	79.50	MPi	83/113			
Megane 1.6L 16V 03/99 → 147						AC5100 (MLS), 1.20mm (30-029743-00)	CC5100 (21-29743-20/0)	
Megane Cabriolet 1.6L 16V 03/99 →								
K4M 700/ K4M 701/ K4M 704/K4M 708	1598	4	79.50	MPi	79/81/ 107/ 109			

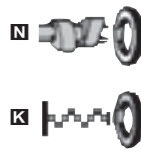
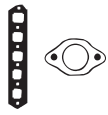

AC5100



AE5200



BX720



BX730



JC956



JN789

HBS102 Ⓢ (22-51001B) M10x1.50x98mm (x5) M10x1.50x113mm (x5)	JC956 ■ JD418 ■ [133]	JN789 (31-026584-00)	PA349 (33-102290-10) 22x16x2mm	HR646 ■ 24-30670-60/0	NA5053 30x42x7mm, FPM (50-319488-00) NA5016 ■ 35x47x7mm, FPM (50-305690-50) NF835 ■ 80x100x8mm, FPM/ACM (50-319239-00)	HL5015 [245]■
HBS102 Ⓢ (22-51001B) M10x1.50x98mm (x5) M10x1.50x113mm (x5)	JC956 ■ JD418 ■ [133]	JN789 (31-026584-00)	PA349 (33-102290-10) 22x16x2mm	HR646 ■ 24-30670-60/0	NA5053 30x42x7mm, FPM (50-319488-00) NA5016 ■ 35x47x7mm, FPM (50-305690-50) NF835 ■ 80x100x8mm, FPM/ACM (50-319239-00)	HL5015 [245]■
HBS299 Ⓢ (22-29019B) M11x1.50x125.0mm (x10)	JD5402 ■ (31-030008-00) KK5643 (31-030009-00)	JM7054 (NBR)		HR817 ■ 24-30614-78/0	NA5215 28x42x5mm, FPM NA5255 ■ 35x47x7mm	HL5026 [245]■
HBS299 Ⓢ (22-29019B) M11x1.50x125.0mm (x10)	JD5402 ■ (31-030008-00) KK5643 (31-030009-00)	JM7054 (NBR)	JH5109 (NBR)	HR817 ■ 24-30614-78/0	NA5215 28x42x5mm, FPM NA5255 ■ 35x47x7mm	HL5026 [245]■
HBS299 Ⓢ (22-29019B) M11x1.50x125.0mm (x10)	JD5402 ■ (31-030008-00)	JM7054 (NBR)	JH5109 (NBR)	HR817 ■ 24-30614-78/0	NA5215 28x42x5mm, FPM NA5255 ■ 35x47x7mm	
HBS299 Ⓢ (22-29019B) M11x1.50x125.0mm (x10)	JD5402 ■ (31-030008-00) KK5643 (31-030009-00)	JM7054 (NBR)		HR817 ■ 24-30614-78/0	NA5215 28x42x5mm, FPM NA5255 ■ 35x47x7mm	HL5026 [245]■
HBS299 Ⓢ (22-29019B) M11x1.50x125.0mm (x10)	JD5402 ■ (31-030008-00)	JM7054 (NBR)	JH5109 (NBR)	HR817 ■ 24-30614-78/0	NA5215 28x42x5mm, FPM NA5255 ■ 35x47x7mm	HL5026 [245]■
HBS299 Ⓢ (22-29019B) M11x1.50x125.0mm (x10)	JD5402 ■ (31-030008-00)	JM7054 (NBR)	JH5109 (NBR)	HR817 ■ 24-30614-78/0	NA5215 28x42x5mm, FPM NA5255 ■ 35x47x7mm	
	JD5393 ■ JD5894 ■ JE5063		JH5108			
HBS301 Ⓢ (22-51107B) M10x1.50x117mm (x10)	JD5393 ■	HR397 [57] 34-000410-00	JH5108 PA349 (33-102290-10) 22x16x2mm		NA5215 (x2) 28x42x5mm, FPM NA5016 ■ 35x47x7mm, FPM (50-305690-50) NF835 ■ 80x100x8mm, FPM/ACM (50-319239-00)	HL5029 [245]■







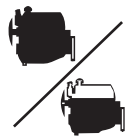



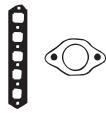

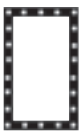































































RENAULT



KW/PS



Megane 1.6L 16V					11/02 →	148	AC5100 (MLS), 1.20mm (30-029743-00)	CC5100 (21-29743-20/0)	
K4M 760	1598	4	79.50	MPi		79/81/ 107/ 109			
K4M 761	1598	4	79.50	MPi		83/113			
Megane 1.6L e					01/96 →03/99	149	BY030 (Fibre) (30-028797-00)	DY030 (21-28797-20/0)	EA220 (22-28798-00/0)
Megane 1.6L i					01/96 →03/99				
Megane Cabriolet 1.6L e					10/96 →03/99				
Megane Scenic 1.6L e					01/97 →09/99				
Megane Scenic 1.6L i					01/97 →09/99				
K7M 720	1598	4	79.50	MPi		55/75			
K7M 702/ K7M 703/K7M 790	1598	4	79.50	MPi		66/89			
Megane 1.8L 16V					01/01 →	150	AD5990 (MLS) (30-029781-00)	CD5991	ED5991
F4P 720/F4P 722	1783	4	82.70	MPi		85/115			
Megane 1.9L D Diesel					09/96 →	151	BS520 (Fibre), 1.65mm, 2 Holes (30-026576-10)	DL961▲ (21-26632-21/0)	EL960 [8] (22-27574-00/0)
Megane 1.9L D Eco Diesel					01/96 →				
Megane Scenic 1.9L D Diesel					03/97 →09/99				
F8Q 620/ F8Q 622/F8Q 790	1870	4	80.00			47/64			
F8Q 624	1870	4	80.00			48/65			
							→+0.868mm		
							BS530 (Fibre), 1.75mm, 1 Hole (30-026577-10)		
							→-0.868 →+1.000mm		
							BS540 (Fibre), 1.85mm, 3 Holes (30-026578-10)		
							→-1.000mm →		
Megane 1.9L dCi Diesel					02/01 →	152	AC5061 (MLS), 1.32mm (30-029473-10)	CC5060▲ (21-29483-20/0)	EC5060 (22-29474-00/0)
F9Q 800	1870	4	80.00			55-88/ 75-120			
F9Q 808	1870	4	80.00	Direct Injection, SOHC		66-75/ 90-102			
F9Q 732	1870	4	80.00			72/98			
F9Q 733	1870	4	80.00			79-88/ 107- 120			
Megane 1.9L dCi Diesel					05/05 →	153	AC5061 (MLS), 1.32mm (30-029473-10)	CC5060▲ (21-29483-20/0)	EC5060 (22-29474-00/0)
F9Q 816/F9Q 818	1870	4	80.00			81-96/ 110- 131			EC5061
F9Q 803	1870	4	80.00	Direct Injection, SOHC		96/131			
F9Q 804	1870	4	80.00	Direct Injection, SOHC					
Megane 1.9L dT Diesel					01/96 →	154	AY710 (Steel Elastomer), 1.36mm, 2 Holes (30-029016-00)	DY040▲ (21-26632-23/0)	EL960 [8] (22-27574-00/0)
Megane 1.9L TDI Diesel					09/96 →				
Megane Scenic 1.9L dT Diesel					01/97 →09/99				
F8Q 786	1870	4	80.00			66/89			
F8Q 784	1870	4	80.00			66-69/ 90-94			
							→-0.073mm		
							AY720 (Steel Elastomer), 1.44mm, 1 Hole (30-029017-00)		
							→-0.073 →+0.206mm		
							AY730 (Steel Elastomer), 1.52mm, 3 Holes (30-029018-00)		
							→-0.206mm →		

								
HBS301  (22-51107B) M10x1.50x117mm (x10)	JD5393  JD5894   JE5063	HR397 [57] 34-000410-00	JH5108 ● PA349 (33-102290-10) 22x16x2mm		 NA5215 (x2) 28x42x5mm, FPM  NA5016  35x47x7mm, FPM (50-305690-50)  NF835  80x100x8mm, FPM/ACM (50-319239-00)	HL5029 [245] 		 AC5100  AY710, AY720, AY730  BS520, BS530, BS540  BY030  JD409  JD463  JN732  JN789  JJ557
HBS102  (22-51001B) M10x1.50x98mm (x5) M10x1.50x113mm (x5)	JD434  JD418 	JN789 (31-026584-00)	● PA349 (33-102290-10) 22x16x2mm	HR646  24-30670-60/0	 NA5053 30x42x7mm, FPM (50-319488-00)  NA5016  35x47x7mm, FPM (50-305690-50)  NF835  80x100x8mm, FPM/ACM (50-319239-00)	HL5015 [245]  NF791 [38]		
HBS310  (22-51108B) M12x1.50x117mm (x10)	JD5908  JD5910 	HR397 [57] 34-000410-00	● PA349 (33-102290-10) 22x16x2mm	PA5013 (x16)	 NA5257 28x47x5.5mm  NA5036  42x54x6mm, FPM (50-319473-00)  NF850  85x105x8mm, FPM (50-319183-00)			
HBS244  (22-51103B) M12x1.50x111mm (x10)	JD409 (31-026628-10)	JN732 (50-026632-00)	JJ557 ● PA349 (33-102290-10) 22x16x2mm	HR569  24-30667-00/0	 NF846 25x42x7mm, FPM/ACM (50-319516-00)  NF843  50x68x10mm, FPM/ACM (50-305667-70)  NF850  85x105x8mm, FPM (50-319183-00)	HL5013 [245]  NF791 [38] KA625 [13] NF849 [15]		
HBS372  (22-51109B) M12x1.50x121mm (x10)	JD5189	JM5086	JH5041 ● KG5012 16x23x1.5mm	HR646  24-30670-60/0	 NF846 25x42x7mm, FPM/ACM (50-319516-00)  NA5036  42x54x6mm, FPM (50-319473-00)  NF850  85x105x8mm, FPM (50-319183-00)	HL5017 [245] 		
HBS372  (22-51109B) M12x1.50x121mm (x10)	JD5189 JD5890 (MLS)  JE5061 (MLS)  JE5062 (MLS)	JM5086	JH5041 ● KG5012 16x23x1.5mm	HR646  24-30670-60/0	 NF846 25x42x7mm, FPM/ACM (50-319516-00)  NA5036  42x54x6mm, FPM (50-319473-00)  NF850  85x105x8mm, FPM (50-319183-00)	HL5017 [245] 		
HBS120  (22-51008B) M12x1.50x118mm (x10)	JD463	JN732 (50-026632-00)	JJ557 ● PA349 (33-102290-10) 22x16x2mm	HR569  24-30667-00/0	 NF846 25x42x7mm, FPM/ACM (50-319516-00)  NF843  50x68x10mm, FPM/ACM (50-305667-70)  NF850  85x105x8mm, FPM (50-319183-00)	HL5013 [245]  NF791 [38] KA625 [13] NF849 [15]		

RENAULT



KW/PS

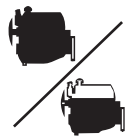

Megane 1.9L dTi Diesel 03/97 → 02/01 155					AC5070 (Fibre), 1.35mm, 2 Notches (30-029474-00) → +0.653mm AC5080 (Fibre), 1.45mm, 1 Notch (30-029475-00) → 0.653 → 0.786mm AC5090 (Fibre), 1.55mm, 3 Notches (30-029476-00) → 0.786mm →	CC5060▲ (21-29483-20/0)	EC5060 (22-29474-00/0)
Megane Scenic 1.9L dTi Diesel 04/97 → 09/99							
F9Q 744	1870	4	80.00		59/80		
F9Q 730/ F9Q 731/ F9Q 734/F9Q 736	1870	4	80.00		72/98		
Megane 2.0L dCi Diesel 09/05 → 156					AG9760 (MLS)	CG9760	EG9760
M9R 700	1995	4	84.00	Direct Injection, DOHC			
Megane 2.0L 09/03 → 157					AD5990 (MLS) (30-029781-00)	CD5991	ED5991
Megane 2.0L 16V 11/02 →							
Megane Cabriolet 2.0L 16V 01/02 →							
F4R 770/F4R 771	1998	4	82.70	MPi	99/135		
Megane 2.0L 16V 01/02 → 158					AD5990 (MLS) (30-029781-00)	CG5420	ED5991
	1998	4					
Megane 2.0L 16V 03/96 → 11/99 159					AD5990 (MLS) (30-029781-00)		EL960 [8] (22-27574-00/0)
Megane Cabriolet 2.0L 16V 10/96 → 11/99							
F7R 714	1998	4	82.70	MPi			
F7R 710	1998	4	82.70	MPi	108- 110/ 147- 150		
Megane 2.0L 16V IDE 11/99 → 160					AG5420 (MLS)	CG5420	ED5991
Megane Cabriolet 2.0L 16V IDE 11/99 →							
F5R 740	1998	4	82.70	Injection	103/140		
Megane 2.0L 16V Turbo 05/04 → 161					AE5110 (MLS) (30-029811-00)	CE5110 (21-29811-20/0)	EE5110 (22-29811-00/0)
F4R 776	1998	4	82.70	MPi, DOHC			
Megane 2.0L i 01/96 → 162					BX600 (Fibre) (30-027850-00)	DX600 (21-27850-20/0)	EL960 [8] (22-27574-00/0)
Megane Cabriolet 2.0L 04/97 →							
Megane Cabriolet 2.0L i 03/99 →							
Megane Scenic 2.0L i 01/97 → 09/99							
F3R 791/F3R 796	1998	4					
F3R 750/F3R 751	1998	4	82.70	MPi	80/109		
F3R 752	1998	4	82.70	MPi	84/114		
	1998	4	82.70	Injection, SOHC	84-80/ 114- 109		
Megane Renault Sport 05/04 → 163					AD5990 (MLS) (30-029781-00)	CD5991	ED5991
F4R 774	1998	4	82.70	Injection, DOHC			
Modus 1.2L 12/04 → 164					AD5980 (MLS) (30-029780-00)	CD5980 (21-29780-20/0)	
Modus 1.2L 16V Hi-Flex 10/08 →							
D4F 740	1149	4	69.00	MPi			
D4F 764	1149	4	69.00	MPi	57/77		

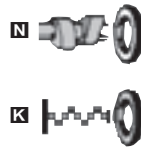
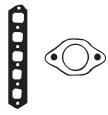

AC5070, AC5080,
AC5090



BX600



JD410



JD411



JD419

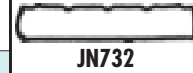

JN732

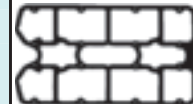

JN996



JJ557

HBS120 (22-511008B) M12x1.50x118mm (x10)	JD5189	JM5086	JH5041 [215] JJ557 F90 730 only ● KG5012 16x23x1.5mm	HR646 24-30670-60/0	NF846 25x42x7mm, FPM/ACM (50-319516-00) NA5036 [215] 42x54x6mm, FPM (50-319473-00) NF850 85x105x8mm, FPM (50-319183-00)	HL5017 [245]
	JD5895 (Steel Elastomer)	HM5291				
HBS310 (22-51108B) M12x1.50x117mm (x10)	JD5908 JD5910	HR397 [57] 34-000410-00	JH5041 ● KG5012 16x23x1.5mm	PA5013 (x16)	NA5257 28x47x5.5mm NA5036 42x54x6mm, FPM (50-319473-00) NF850 85x105x8mm, FPM (50-319183-00)	HL5039 [245]
HBS310 (22-51108B) M12x1.50x117mm (x10)	JD5889 (Steel Elastomer)	HR397 [57] 34-000410-00	JH5041 ● KG5012 16x23x1.5mm	PA5013 (x16)	NA5036 42x54x6mm, FPM (50-319473-00) NF850 85x105x8mm, FPM (50-319183-00)	HL5039 [245]
HBS177 (22-51003B) M12x1.50x108mm (x10)	JD411 (31-026592-10) JD410 (31-026593-10)	JN996	● PB852 16x24x1.5mm ● PA349 (33-102290-10) 22x16x2mm	HR646 (x2) 24-30670-60/0	NF846 25x42x7mm, FPM/ACM (50-319516-00) NF843 50x68x10mm, FPM/ACM (50-305667-70) NF850 85x105x8mm, FPM (50-319183-00)	HL5013 [245] KA625 [13] NF849 [15]
HBS431 (22-51111B)	JD5889 (Steel Elastomer)	HR397 [57] 34-000410-00	JH5041 ● KG5012 16x23x1.5mm	PA5013 (x16)	NA5257 28x47x5.5mm NA5036 42x54x6mm, FPM (50-319473-00) NF850 85x105x8mm, FPM (50-319183-00)	HL5039 [245]
HBS310 (22-51108B) M12x1.50x117mm (x10)	JD5911 JD5910	HR397 [57] 34-000410-00	JH5041 ● KG5012 16x23x1.5mm	PA5013 (x16)	NA5257 28x47x5.5mm NA5036 42x54x6mm, FPM (50-319473-00) NF850 85x105x8mm, FPM (50-319183-00)	HL5039 [245]
HBS244 (22-51103B) M12x1.50x111mm (x10)	JD419 (31-027573-00)	JN732 (50-026632-00)	JJ557 ● PA349 (33-102290-10) 22x16x2mm	HR569 24-30667-00/0	NF846 25x42x7mm, FPM/ACM (50-319516-00) NF847 22x45x7mm, FPM/ACM NF843 50x68x10mm, FPM/ACM (50-305667-70) NF850 85x105x8mm, FPM (50-319183-00)	HL5013 [245] NF791 [38] KA625 [13] NF849 [15]
HBS310 (22-51108B) M12x1.50x117mm (x10)			JH5041 ● KG5012 16x23x1.5mm	PA5013 (x16)	NA5257 28x47x5.5mm NA5036 42x54x6mm, FPM (50-319473-00) NF850 85x105x8mm, FPM (50-319183-00)	
HBS283 (22-72004B) M9x1.25x122mm (x10)	JD5885 JD5884	JM7053 (ACM)			NA5261 28x47x8mm, PTFE	HL5036 [245]











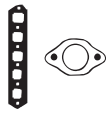

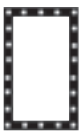

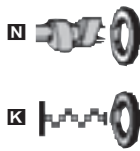

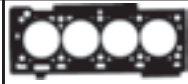



































































































RENAULT



KW/PS



Model					Year Range	Power (KW/PS)	Engine Code	Stroke	Accessories
Modus 1.4L					12/04 →	165	AC5100 (MLS), 1.20mm (30-029743-00)		CC5100 (21-29743-20/0)
K4J 770	1390	4	79.50	MPi		72/98			
Modus 1.5L dCi Diesel					12/04 →	166	AG9490 (MLS) (30-029497-00)		EE5200
K9K 768	1461	4	76.00			50/68			
Modus 1.5L dCi Diesel					12/04 →	167	AG9490 (MLS) (30-029497-00)		EE5200
K9K 766	1461	4	76.00			63/86			
Modus 1.5L dCi Diesel					12/04 →	168	AG9490 (MLS) (30-029497-00)		EE5200
K9K 752	1461	4	76.00	Direct Injection, SOHC		48-50/ 65-68			
K9K 764	1461	4	76.00			78/106			
Modus 1.6L					12/04 →	169	AC5100 (MLS), 1.20mm (30-029743-00)		CC5100 (21-29743-20/0)
K4M 792/K4M 794	1598	4	79.50	Injection, DOHC		65/88			
Modus 1.6L					12/04 →	170	AC5100 (MLS), 1.20mm (30-029743-00)		CC5110
K4M 790/K4M 791	1598	4	79.50	Injection, DOHC		82/112			
R4 0.8L					10/62 → 09/83	171	BF350 (Fibre), 1.50mm		DF351 ◻ ◯ (21-18032-26/0)
800/800 705	847	4	58.00	Carburettor		27/37		GF356 ◻ [36]	
R4 1.0L					06/87 → 06/93	172	BH680 (Fibre), 1.20mm (30-024764-10) BM790 (Fibre), 1.75mm [34]		DH681 ◻ (21-24764-24/0) EH684 [36] GH683 ◻ [36]
C1C 708	956	4	65.00	Carburettor		25/34			
R4 1.0L					12/85 → 06/93	173	BH680 (Fibre), 1.20mm (30-024764-10) BM790 (Fibre), 1.75mm [34]		DH681 ◻ (21-24764-24/0) EH684 [36] GH683 ◻ [36]
689 710	956	4	65.00	Carburettor		32/44			
R4 Van 1.0L					06/87 → 12/93	174	BH680 (Fibre), 1.20mm (30-024764-10) BM790 (Fibre), 1.75mm [34]		DH681 ◻ (21-24764-24/0) EH684 [36] GH683 ◻ [36]
C1C 708	956	4	65.00	Carburettor		25/34			
R4 1.1L					06/78 → 06/90	175	BH680 (Fibre), 1.20mm (30-024764-10) BM790 (Fibre), 1.75mm [34]		DH681 ◻ (21-24764-24/0) EH684 [36] GH683 ◻ [36]
R4 Van 1.1L					10/76 → 07/89				
688 12/C1E 714	1108	4	70.00	Carburettor		25/34			
C1E 718/C1E 719	1108	4	70.00	Carburettor		25-26/ 34-35			
688 11	1108	4	70.00	Carburettor		33/45			
R5 1.0L					01/72 → 12/85	176	BH680 (Fibre), 1.20mm (30-024764-10) BM790 (Fibre), 1.75mm [34]		DH681 ◻ (21-24764-24/0) EH684 [36] 01/76 → Eng.597296 → GH683 ◻ [36] 01/76 → Eng.597296 →
R5 Van 1.0L					01/72 → 12/85				
689 710	956	4	65.00	Carburettor		32/44			

								 AC5100	 BF350	 BH680, BM790	 JB850	 JB851	 JN248	 JN251	 HC354	 HC375
HBS301  (22-51107B) M10x1.50x117mm (x10)	JD5393  JD5893  (FPM) JD5394 	HR397 [57] 34-000410-00	JH5108	PA5013 (x16)	 NA5215 28x42x5mm, FPM  NA5016  35x47x7mm, FPM (50-305690-50)  NF835  80x100x8mm, FPM/ACM (50-319239-00)	HL5029 [245] 										
HBS299  (22-29019B) M11x1.50x125.0mm (x10)	JD5402  (31-030008-00)  KK5643 (31-030009-00)	JM7054 (NBR)	JH5109 (NBR)	HR817  24-30614-78/0	 NA5215 28x42x5mm, FPM  NA5255  35x47x7mm	HL5026 [245] 										
HBS299  (22-29019B) M11x1.50x125.0mm (x10)	JD5402  (31-030008-00)	JM7054 (NBR)	JH5109 (NBR)	HR817  24-30614-78/0	 NA5215 28x42x5mm, FPM  NA5255  35x47x7mm											
HBS299  (22-29019B) M11x1.50x125.0mm (x10)	JD5402  (31-030008-00)	JM7054 (NBR)	JH5109 (NBR)	HR817  24-30614-78/0	 NA5215 28x42x5mm, FPM  NA5255  35x47x7mm											
HBS301  (22-51107B) M10x1.50x117mm (x10)		HR397 [57] 34-000410-00	 PA349 (33-102290-10) 22x16x2mm		 NA5215 (x2) 28x42x5mm, FPM  NA5016  35x47x7mm, FPM (50-305690-50)  NF835  80x100x8mm, FPM/ACM (50-319239-00)	HL5029 [245] 										
HBS301  (22-51107B) M10x1.50x117mm (x10)	JD5894   JE5063	HR397 [57] 34-000410-00	JH5109 (NBR)  PA349 (33-102290-10) 22x16x2mm		 NA5215 (x2) 28x42x5mm, FPM  NA5016  35x47x7mm, FPM (50-305690-50)  NF835  80x100x8mm, FPM/ACM (50-319239-00)	HL5029 [245] 										
	JB850  (x2) (31-023208-10)	JN251	HC375   KJ647 18.3x24x2mm				NF541 (x2) [2]   KA527 [13] LT832 [46]									
HBS104  (22-51005B) M10x1.50x100mm (x10)	JB851 (31-022715-10)	JN248 (50-026305-00)	 KJ647 18.3x24x2mm		 NF535 30x42x8mm, NBR  NF834  35x50x8mm, FPM (50-319241-00)  NF835  80x100x8mm, FPM/ACM (50-319239-00)	HR350 [37]  JR635 [11]										
HBS104  (22-51005B) M10x1.50x100mm (x10)	JB851 (31-022715-10)	JN248 (50-026305-00)	 KJ647 18.3x24x2mm		 NF834  35x50x8mm, FPM (50-319241-00)  NF835  80x100x8mm, FPM/ACM (50-319239-00)	HR350 [37]  JR635 [11]										
HBS104  (22-51005B) M10x1.50x100mm (x10)	JB851 (31-022715-10)	JN248 (50-026305-00)	HC354   KJ647 18.3x24x2mm		 NF535 30x42x8mm, NBR  NF834  35x50x8mm, FPM (50-319241-00)  NF835  80x100x8mm, FPM/ACM (50-319239-00)	HR350 [37]  NF541 (x2) [2]   NF775 (x2) [38]										
HBS104  (22-51005B) M10x1.50x100mm (x10)	JB851 (31-022715-10)	JN248 (50-026305-00)	HC354   KJ647 18.3x24x2mm		 NF535 30x42x8mm, NBR  NF834  35x50x8mm, FPM (50-319241-00)  NF835  80x100x8mm, FPM/ACM (50-319239-00)	HR350 [37]  NF541 (x2) [2]   NF775 (x2) [38]										
HBS104  (22-51005B) M10x1.50x100mm (x10)	JB851 (31-022715-10)	JN248 (50-026305-00)	 KJ647 18.3x24x2mm HC354  01/76 → Eng.597296 →		 NF535 30x42x8mm, NBR  NF834  35x50x8mm, FPM (50-319241-00)  NF835  80x100x8mm, FPM/ACM (50-319239-00) 01/76 → Eng.597296 →	HR350 [37]  NF541 (x2) [2]   NF775 (x2) [38] JR635 [11]										

RENAULT



KW/PS



R5 1.0L Super 10/84 → 10/88 177						BH680 (Fibre), 1.20mm (30-024764-10)	DH683 ■ ○ (21-24764-25/0)	EH680 (22-20518-01/0)
R5 Van 1.0L Super 10/84 → 10/88								
C1C 700	956	4	65.00	Carburettor	30/41	BM790 (Fibre), 1.75mm [34]	DH687 ■ DN684 ■ ▲ ○	
R5 1.1L 09/80 → 12/85 178						BH680 (Fibre), 1.20mm (30-024764-10)	DH681 ○ (21-24764-24/0)	EH684 [36] GH683 ○ [36]
R5 Van 1.1L 09/80 → 12/85								
688 13/C1E 726	1108	4	70.00	Carburettor	33/45	BM790 (Fibre), 1.75mm [34]	DH685 ▲ ■	
R5 1.1L Super 10/84 → 03/95 179						BH680 (Fibre), 1.20mm (30-024764-10)	DH683 ■ ○ (21-24764-25/0)	EH680 (22-20518-01/0)
R5 Van 1.1L Super 10/84 → 12/96								
C1E 756/C1E 760	1108	4	70.00	Carburettor	33/45	BM790 (Fibre), 1.75mm [34]	DH687 ■ DN684 ■ ▲ ○	
C1E 750/	1108	4	70.00	Carburettor	33-34/			
C1E 752/C1E 754					45-46			
R5 1.2L Super 01/87 → 08/90 180						BH690 (Fibre), 1.20mm (30-024733-10)	DH687 ■ DH693 ■ ○ DN684 ■ ▲ ○	EH680 (22-20518-01/0)
R5 Van 1.2L Super 01/87 → 08/90								
C1G 702/ C1G 720/C1G 722	1237	4	71.50	Carburettor	40/54	BM800 (Fibre), 1.75mm [34]		
R5 1.4L 01/82 → 12/85 181						BH690 (Fibre), 1.20mm (30-024733-10)	DH685 ▲ ■	EF731 [36]
R5 Van 1.4L 01/82 → 12/85								
847 725	1397	4	76.00	Carburettor	43-46/ 59-63	BM800 (Fibre), 1.75mm [34]		
C2J 713	1397	4	76.00	Carburettor	46/63			
R5 1.4L Alpine Turbo 10/81 → 01/85 182						BF730 (Fibre), 1.40mm	DF731 ■ ○	EF731 [36]
R5 1.4L Turbo 06/80 → 01/85								
C6J 750	1397	4	76.00	Carburettor	79-81/ 108- 110			
840 726	1397	4	76.00		81/110			
840 730	1397	4	76.00	K-Jetronic	118/160			
R5 1.4L Super 10/84 → 12/96 183						BH690 (Fibre), 1.20mm (30-024733-10)	DH687 ■ DH693 ■ ○ DN684 ■ ▲ ○	EH680 (22-20518-01/0)
R5 Van 1.4L Super 10/84 → 12/96								
C1J 780	1397	4	76.00	Carburettor	43/58	BM800 (Fibre), 1.75mm [34]		
C1J 768	1397	4	76.00	Carburettor	43-44/ 58-60			
C3J 700/ C3J 702/C3J 760	1397	4	76.00	SPi	43-44/ 58-60			
C2J 784	1397	4	76.00	Carburettor	44/60			
C2J 782	1397	4	76.00	Carburettor	49/67			
C2J 700/C2J 780/C2J 781/ C2J 788/C2J 789/C2J 798	1397	4	76.00	Carburettor	52-53/ 71-72			
R5 1.4L Turbo GT Super 01/85 → 05/91 184						BF730 (Fibre), 1.40mm	DF731 ■ ○	EF731 [36]
840 730	1397	4	76.00	K-Jetronic	118/160			
R5 1.4L Turbo Super 04/85 → 08/90 185						BN360 (Fibre), 1.90mm (30-027578-00)	DN360 ■ ○ (21-27578-20/0) DN361 ▲ ■ ○ (21-26305-21/0)	EH682 [36]
R5 Van 1.4L Turbo Super 04/85 → 08/90								
C1J 782/C1J 788	1397	4	76.00		85/88/ 115/ 120			
C1J 784	1397	4	76.00	Carburettor	85-88/ 115- 120			

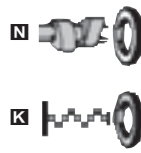
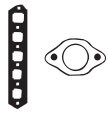

BF730



BH680, BM790,
BH690



BM800



BN360



JB851



JC669



JN248



JN369



JN600



HC354

HBS104 (22-51005B) M10x1.50x100mm (x10)	JC669 (31-026620-10)	JN600	HC486 ● PA349 (33-102290-10) 22x16x2mm	HR643	<input checked="" type="checkbox"/> NF834 35x50x8mm, FPM (50-319241-00) <input checked="" type="checkbox"/> NF835 80x100x8mm, FPM/ACM (50-319239-00)	HR350 [37] <input checked="" type="checkbox"/> NF791 [38] <input checked="" type="checkbox"/> JR635 [11]
HBS104 (22-51005B) M10x1.50x100mm (x10)	JB851 (31-022715-10)	JN248 (50-026305-00)	HC354 ● KJ647 18.3x24x2mm	HR643	<input checked="" type="checkbox"/> NF535 30x42x8mm, NBR <input checked="" type="checkbox"/> NF834 35x50x8mm, FPM (50-319241-00) <input checked="" type="checkbox"/> NF835 80x100x8mm, FPM/ACM (50-319239-00)	HR350 [37] <input checked="" type="checkbox"/> NF541 (x2) [2] <input checked="" type="checkbox"/> <input checked="" type="checkbox"/> NF775 (x2) [38]
HBS104 (22-51005B) M10x1.50x100mm (x10)	JC669 (31-026620-10)	JN600	HC486 ● PA349 (33-102290-10) 22x16x2mm	HR643	<input checked="" type="checkbox"/> NF834 35x50x8mm, FPM (50-319241-00) <input checked="" type="checkbox"/> NF835 80x100x8mm, FPM/ACM (50-319239-00)	HR350 [37] <input checked="" type="checkbox"/> NF791 [38] <input checked="" type="checkbox"/> JR635 [11]
HBS104 (22-51005B) M10x1.50x100mm (x10)	JC669 (31-026620-10)	JN600	HC486 ● PA349 (33-102290-10) 22x16x2mm	HR643	<input checked="" type="checkbox"/> NF834 35x50x8mm, FPM (50-319241-00) <input checked="" type="checkbox"/> NF835 80x100x8mm, FPM/ACM (50-319239-00)	HR378 [37] <input checked="" type="checkbox"/> NF791 [38] <input checked="" type="checkbox"/> JR635 [11]
HBS104 (22-51005B) M10x1.50x100mm (x10)	JB851 (31-022715-10)	JN248 (50-026305-00)	HC354 ● KJ647 18.3x24x2mm	HR643	<input checked="" type="checkbox"/> NF535 30x42x8mm, NBR <input checked="" type="checkbox"/> NF834 35x50x8mm, FPM (50-319241-00) <input checked="" type="checkbox"/> NF835 80x100x8mm, FPM/ACM (50-319239-00)	HR564 [37] <input checked="" type="checkbox"/> NF541 (x2) [2] <input checked="" type="checkbox"/> <input checked="" type="checkbox"/> NF775 (x2) [38] 5 door NF814 (x2) [38]
		JN369 (31-025215-00)	HC354 ● KJ647 18.3x24x2mm		<input checked="" type="checkbox"/> NF535 30x42x8mm, NBR <input checked="" type="checkbox"/> NF834 35x50x8mm, FPM (50-319241-00) <input checked="" type="checkbox"/> NF835 80x100x8mm, FPM/ACM (50-319239-00)	HR564 [37] <input checked="" type="checkbox"/> NF541 (x2) [2] <input checked="" type="checkbox"/> <input checked="" type="checkbox"/> NF814 (x2) [38] KA533 [13] JR635 [11] LT832 [46]
HBS104 (22-51005B) M10x1.50x100mm (x10)	JC669 (31-026620-10)	JN600	HC486 ● PA349 (33-102290-10) 22x16x2mm	HR643	<input checked="" type="checkbox"/> NF834 35x50x8mm, FPM (50-319241-00) <input checked="" type="checkbox"/> NF835 80x100x8mm, FPM/ACM (50-319239-00)	HR564 [37] <input checked="" type="checkbox"/> NF791 [38] <input checked="" type="checkbox"/> JR635 [11]
		JN369 (31-025215-00)	HC354 ● KJ647 18.3x24x2mm		<input checked="" type="checkbox"/> NF535 30x42x8mm, NBR <input checked="" type="checkbox"/> NF834 35x50x8mm, FPM (50-319241-00) <input checked="" type="checkbox"/> NF835 80x100x8mm, FPM/ACM (50-319239-00)	HR564 [37] <input checked="" type="checkbox"/> KA533 [13] JR635 [11]
HBS104 (22-51005B) M10x1.50x100mm (x10)	JC669 (31-026620-10)	JN600	HC486 ● PA349 (33-102290-10) 22x16x2mm		<input checked="" type="checkbox"/> NF834 35x50x8mm, FPM (50-319241-00) <input checked="" type="checkbox"/> NF835 80x100x8mm, FPM/ACM (50-319239-00) <input checked="" type="checkbox"/> NF634 [216] 80x100x13mm, MVQ (50-319343-00)	HR564 [37] <input checked="" type="checkbox"/>



KW/PS

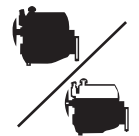

R5 1.6L D Super Diesel		10/84 → 12/96		186				
F8M 720/F8M 730	1595	4	78.00		40/54	BL970 (Fibre), 1.75mm, 1 Hole (30-026969-10) →03/88 ☒0.885→0.985mm BL980 (Fibre), 1.85mm, 3 Holes →03/88 ☒0.985mm→ BS010 (Fibre), 1.65mm, 2 Holes (30-025301-20) 04/88→ ☒→0.885mm BS020 (Fibre), 1.75mm, 1 Hole (30-025302-20) 04/88→ ☒0.885→0.985mm BS030 (Fibre), 1.85mm, 3 Holes (30-025303-20) 04/88→ ☒0.985mm→	DL961▲ (21-26632-21/0)	EL960 [8] (22-27574-00/0)
R5 1.7L i Super		10/86 → 08/91		187				
R5 1.7L Super		10/86 → 03/95				BL910 (Fibre), 1.20mm (30-026613-00)	DL910 DL911 (21-26613-23/0)	EL960 [8] (22-27574-00/0)
F3N 716/F3N 717	1721	4	81.00	SPi	54-55/ 73-75			
F2N 740/F2N 742	1721	4	81.00	Carburettor	64-66/ 87-90			
F3N 722	1721	4	81.00	MPi	66-70/ 90-95			
F3N 702	1721	4	81.00	MPi	68-69/ 92-94			
R6 1.1L		08/70 → 04/87		188				
688.10	1108	4	70.00	OHV	25-39/ 34-53	BH680 (Fibre), 1.20mm (30-024764-10) BM790 (Fibre), 1.75mm [34]	DH681○ (21-24764-24/0) DH685▲■	EH684 [36] GH683○ [36]
R9 1.1L		09/81 → 05/87		189				
C1E 715/C1E 720	1108	4	70.00	Carburettor	35/47	BH680 (Fibre), 1.20mm (30-024764-10) BM790 (Fibre), 1.75mm [34]	DH683■○ (21-24764-25/0) DH687■ DN684■▲○	EH680 (22-20518-01/0)
R9 1.2L		09/85 → 12/88		190				
C1G 700/C1G 710	1237	4	71.50	Carburettor	40/54	BH680 (Fibre), 1.20mm (30-024764-10) BH690 (Fibre), 1.20mm (30-024733-10) BM790 (Fibre), 1.75mm [34]	DH683■○ (21-24764-25/0) DH687■ DN684■▲○	EH680 (22-20518-01/0)
R9 1.4L		12/81 → 12/88		191				
C1J 715/ C1J 792/ C1J 796/C2J 730	1397	4	76.00	Carburettor	44/60	BH690 (Fibre), 1.20mm (30-024733-10) BM800 (Fibre), 1.75mm [34]	DH690■○ DN684■▲○	EH680 (22-20518-01/0)
C2J 720/ C2J 766/C2J 767	1397	4	76.00	Carburettor	49/67			
C2J 768	1397	4	76.00	Carburettor	49-50/ 67-68			
R9 1.4L Turbo		04/84 → 12/86		192				
C1J 760/C1J 764	1397	4	76.00	Carburettor	77/105	BN360 (Fibre), 1.90mm (30-027578-00)	DN360■○ (21-27578-20/0) DN361▲■○ (21-26305-21/0)	EH682 [36]

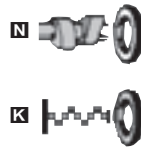
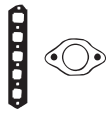

BH680, BM790,
BH690



BL910



BL970, BL980



BM800



BN360



BS010, BS020,
BS030

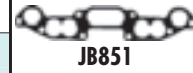

JB851



JB997



JC669



JD409



JN248



JN600



JN732



JJ557

HBS244
(22-51103B)
M12x1.50x111mm (x10)

JD409
(31-026628-10)

JN732
(50-026632-00)

JJ557
● **PA349**
(33-102290-10)
22x16x2mm

HR569
24-30667-00/0

NF846 25x42x7mm, FPM/ACM
(50-319516-00)
 NF843 50x68x10mm, FPM/ACM
(50-305667-70)
 NF850 85x105x8mm, FPM
(50-319183-00)

HL5013 [245]
NF791 [38]
KA625 [13]
NF849 [15]

HBS244
(22-51103B)
M12x1.50x111mm (x10)

JD409
(31-026628-10)

JN732
(50-026632-00)

JJ557
● **PA349**
(33-102290-10)
22x16x2mm

HR569
24-30667-00/0

NF846 25x42x7mm, FPM/ACM
(50-319516-00)
 NF847 22x45x7mm, FPM/ACM
 NF843 50x68x10mm, FPM/ACM
(50-305667-70)
 NF850 85x105x8mm, FPM
(50-319183-00)

HL5013 [245]
NF791 [38]
KA625 [13]
NF849 [15]

HBS104
(22-51005B)
M10x1.50x100mm (x10)

JB851
(31-022715-10)

JN248
(50-026305-00)

● **KJ647**
18.3x24x2mm

HR569

NF535 30x42x8mm, NBR
 NF834 35x50x8mm, FPM
(50-319241-00)
 NF835 80x100x8mm, FPM/ACM
(50-319239-00)

HR350 [37]
NF775 (x2) [38]

HBS104
(22-51005B)
M10x1.50x100mm (x10)

JC669
(31-026620-10)

JN600

HC486
● **PA349**
(33-102290-10)
22x16x2mm

HR643

NF834 35x50x8mm, FPM
(50-319241-00)
 NF835 80x100x8mm, FPM/ACM
(50-319239-00)

HR350 [37]
NF791 [38]

HBS104
(22-51005B)
M10x1.50x100mm (x10)

JC669
(31-026620-10)

JN600

HC486
● **PA349**
(33-102290-10)
22x16x2mm

HR643

NF834 35x50x8mm, FPM
(50-319241-00)
 NF835 80x100x8mm, FPM/ACM
(50-319239-00)

HR378 [37]
NF791 [38]

HBS104
(22-51005B)
M10x1.50x100mm (x10)

JB997
JC669
(31-026620-10)

JN600

HC486
● **PA349**
(33-102290-10)
22x16x2mm

HR643

NF834 35x50x8mm, FPM
(50-319241-00)
 NF835 80x100x8mm, FPM/ACM
(50-319239-00)

HR564 [37]
NF791 [38]

HBS104
(22-51005B)
M10x1.50x100mm (x10)

JC669
(31-026620-10)

JN600

HC486
● **PA349**
(33-102290-10)
22x16x2mm

HR643

NF834 35x50x8mm, FPM
(50-319241-00)
 NF835 80x100x8mm, FPM/ACM
(50-319239-00)

HR564 [37]
NF791 [38]



KW/PS



R9 1.6L D Diesel		10/82 → 12/88		193				
F8M 700/ F8M 720/F8M 730	1595	4	78.00		40/54	BL960 (Fibre), 1.65mm, 2 Holes [33] (30-026968-10) →0.885mm BL970 (Fibre), 1.75mm, 1 Hole (30-026969-10) →03/88 →0.885→0.985mm BL980 (Fibre), 1.85mm, 3 Holes →03/88 →0.985mm→ BS010 (Fibre), 1.65mm, 2 Holes (30-025301-20) 04/88→ →0.885mm BS020 (Fibre), 1.75mm, 1 Hole (30-025302-20) 04/88→ →0.885→0.985mm BS030 (Fibre), 1.85mm, 3 Holes (30-025303-20) 04/88→ →0.985mm→	DL961▲ (21-26632-21/0)	EL960 [8] (22-27574-00/0)
R9 1.7L		09/84 → 12/88		194				
F2N 730	1721	4	81.00	Carburettor	54-55/ 73-75	BL910 (Fibre), 1.20mm (30-026613-00)	DL910 DL911 (21-26613-23/0)	EL960 [8] (22-27574-00/0)
F3N 718	1721	4	81.00	SPi	54-55/ 73-75			
F2N 700/F2N 704	1721	4	81.00	Carburettor	59/80			
F2N 708/ F2N 710/F2N 798	1721	4	81.00	Carburettor	65/88			
F3N 708	1721	4	81.00	MPi	69/93			
R11 1.1L		03/83 → 06/86		195				
R11 Van 1.1L		03/83 → 06/86						
C1E 715/C1E 720	1108	4	70.00	Carburettor	35/47	BH680 (Fibre), 1.20mm (30-024764-10) BM790 (Fibre), 1.75mm [34]	DH683■○ (21-24764-25/0) DH687■ DN684■▲○	EH680 (22-20518-01/0)
R11 1.2L		10/84 → 12/88		196				
R11 Van 1.2L		10/84 → 12/88						
C1G 700/C1G 710	1237	4	71.50	Carburettor	40/54	BH690 (Fibre), 1.20mm (30-024733-10) BM800 (Fibre), 1.75mm [34]	DH693■○ DH699■ DN684■▲○	EH680 (22-20518-01/0)
R11 1.4L		03/83 → 12/88		197				
R11 Van 1.4L		03/83 → 09/86						
C1J 715/C2J 730	1397	4	76.00	Carburettor	44/60	BH690 (Fibre), 1.20mm (30-024733-10) BM800 (Fibre), 1.75mm [34]	DH687■ DH693■○ DN684■▲○	EH680 (22-20518-01/0)
C2J 720/ C2J 766/C2J 767	1397	4	76.00	Carburettor	49/67			
C2J 718/ C2J 757/C2J 768	1397	4	76.00	Carburettor	49-50/ 67-68			
C2J 717/C2J 755	1397	4	76.00	Carburettor	53/72			
R11 1.4L Turbo		04/84 → 12/88		198				
C1J 760/C1J 764	1397	4	76.00	Carburettor	77/105	BN360 (Fibre), 1.90mm (30-027578-00)	DN360■○ (21-27578-20/0) DN361▲■○ (21-26305-21/0)	EH682 [36]
C1J 770	1397	4	76.00	Carburettor	85/115			
C1J 782	1397	4	76.00		85/88/ 115/ 120			

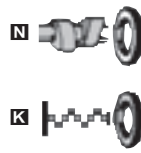
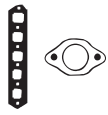





HBS244 
(22-51103B)
M12x1.50x111mm (x10)



JD409
(31-026628-10)

JN555
JN732
(50-026632-00)

JJ557
● **PA349**
(33-102290-10)
22x16x2mm

HR569 
24-30667-00/0

 **NF846** 25x42x7mm, FPM/ACM
(50-319516-00)
 **NF843** 50x68x10mm, FPM/ACM
(50-305667-70)
 **NF850** 85x105x8mm, FPM
(50-319183-00)

HL5013 [245] 
NF791 [38] 
KA625 [13]
NF849 [15]

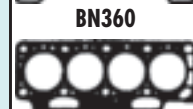
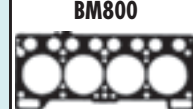
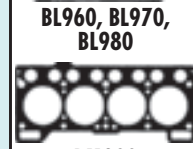
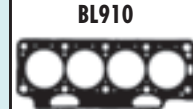
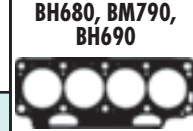



HBS244 
(22-51103B)
M12x1.50x111mm (x10)



JD409
(31-026628-10)

JN732
(50-026632-00)

JJ557
● **PA349**
(33-102290-10)
22x16x2mm

HR569 
24-30667-00/0

 **NF846** 25x42x7mm, FPM/ACM
(50-319516-00)
 **NF843** 50x68x10mm, FPM/ACM
(50-305667-70)
 **NF850** 85x105x8mm, FPM
(50-319183-00)

HL5013 [245] 
NF791 [38] 
KA625 [13]
NF849 [15]



HBS104 
(22-51005B)
M10x1.50x100mm (x10)



JC669
(31-026620-10)

JN600

HC486 
● **PA349**
(33-102290-10)
22x16x2mm

HR643 

 **NF834** 35x50x8mm, FPM
(50-319241-00)
 **NF835** 80x100x8mm, FPM/ACM
(50-319239-00)

HR350 [37] 
NF791 [38] 
LT839 [13]
JR635 [11]



HBS104 
(22-51005B)
M10x1.50x100mm (x10)



JC669
(31-026620-10)

JN600

HC486 
● **PA349**
(33-102290-10)
22x16x2mm

HR643 

 **NF834** 35x50x8mm, FPM
(50-319241-00)
 **NF835** 80x100x8mm, FPM/ACM
(50-319239-00)

HR378 [37] 
NF791 [38] 
LT839 [13]
JR635 [11]



HBS104 
(22-51005B)
M10x1.50x100mm (x10)



JC669
(31-026620-10)

JN600

HC486 
● **PA349**
(33-102290-10)
22x16x2mm

HR643 

 **NF834** 35x50x8mm, FPM
(50-319241-00)
 **NF835** 80x100x8mm, FPM/ACM
(50-319239-00)

HR564 [37] 
NF791 [38] 
LT839 [13]
JR635 [11]



HBS104 
(22-51005B)
M10x1.50x100mm (x10)

JC669
(31-026620-10)

JN600

HC486 
● **PA349**
(33-102290-10)
22x16x2mm

HR643 

 **NF834** 35x50x8mm, FPM
(50-319241-00)
 **NF835** 80x100x8mm, FPM/ACM
(50-319239-00)

HR564 [37] 
NF791 [38]
LT839 [13]
JR635 [11]



KW/PS

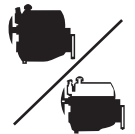

R11 1.6L D Diesel					08/83 → 12/88	199	BL960 (Fibre), 1.65mm, 2 Holes [33] (30-026968-10) → +0.885mm		DL961▲ (21-26632-21/0)	EL960 [8] (22-27574-00/0)
R11 Van 1.6L D Diesel					08/83 → 12/88		BL970 (Fibre), 1.75mm, 1 Hole (30-026969-10) → +0.885mm			
F8M 700/ F8M 720/F8M 730	1595	4	78.00			40/54	BL980 (Fibre), 1.85mm, 3 Holes → +0.885mm			
							BSO10 (Fibre), 1.65mm, 2 Holes (30-025301-20) 04/88 → → +0.885mm			
							BSO20 (Fibre), 1.75mm, 1 Hole (30-025302-20) 04/88 → → +0.885mm			
							BSO30 (Fibre), 1.85mm, 3 Holes (30-025303-20) 04/88 → → +0.985mm			
R11 1.7L					10/83 → 12/88	200	BL910 (Fibre), 1.20mm (30-026613-00)		DL910 DL911 (21-26613-23/0)	EL960 [8] (22-27574-00/0)
F2N 730	1721	4	81.00	Carburettor		54-55/ 73-75				
F3N 718	1721	4	81.00	SPi		54-55/ 73-75				
F2N 700/F2N 704	1721	4	81.00	Carburettor		59/80				
F2N 732	1721	4	81.00	Carburettor		64/87				
F2N 742	1721	4	81.00	Carburettor		64-66/ 87-90				
F2N 708/ F2N 710/F2N 798	1721	4	81.00	Carburettor		65/88				
F3N 708	1721	4	81.00	MPi		69/93				
R12 1.3L					10/69 → 08/80	201	BTO80 (Fibre), 1.50mm		DH686■▲○	EF380 [36] 01/76 → GT083■○ [36]
810.02	1289	4	73.00	Carburettor		40/54				
R18 1.6L					04/78 → 07/86	202			DF873○	EF870 [36] GF874○ [36]
R18 1.6L 4x4					01/83 → 07/86					
841 717/A2M 723	1647	4	79.00	Carburettor		54/73				
841.25/841.26	1647	4	79.00	Carburettor		58/79				
R18 1.6L TS					05/82 → 07/86	203			DF871○	EF870 [36]
A6M 725/A6M 726	1647	4	79.00	Carburettor		71/96				
R18 1.6L Turbo					10/80 → 07/86	204	BTO80 (Fibre), 1.50mm			EF870 [36]
R18 1.6L Turbo Inj.					09/82 → 07/86					
807 727	1565	4	77.00	Carburettor		63/85				
A5L 717/A5L 718	1565	4	77.00	Carburettor		92/125				
A7L 752	1647	4	79.00	Carburettor		80-82/ 109- 112				

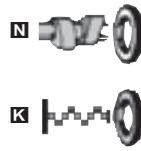
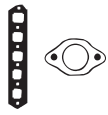

BL910



BL960, BL970,
BL980



BS010, BS020,
BS030



BT080



JB851



JB855



JD409



JE648



JN248



JN732



HC354



JJ557





HBS244 
(22-51103B)
M12x1.50x111mm (x10)



JD409
(31-026628-10)

JN732
(50-026632-00)

JJ557
● **PA349**
(33-102290-10)
22x16x2mm

HR569 
24-30667-00/0

 **NF846** 25x42x7mm, FPM/ACM
(50-319516-00)
 **NF843**  50x68x10mm, FPM/ACM
(50-305667-70)
 **NF850**  85x105x8mm, FPM
(50-319183-00)

HL5013 [245] 
NF791 [38] 
KA625 [13]
NF849 [15]





HBS244 
(22-51103B)
M12x1.50x111mm (x10)



JD409
(31-026628-10)

JN732
(50-026632-00)

JJ557
● **PA349**
(33-102290-10)
22x16x2mm

HR569 
24-30667-00/0

 **NF846** 25x42x7mm, FPM/ACM
(50-319516-00)
 **NF843**  50x68x10mm, FPM/ACM
(50-305667-70)
 **NF850**  85x105x8mm, FPM
(50-319183-00)

HL5013 [245] 
NF791 [38] 
KA625 [13]
NF849 [15]



HBS104 
(22-51005B)
M10x1.50x100mm (x10)

JB851
(31-022715-10)
 **JE648**

JN248
(50-026305-00)



● **KJ647**
18.3x24x2mm
HC354 
01/76 →







 **NF535** 30x42x8mm, NBR
 **NF722**  35x50x10mm, MVQ
 **NF834**  35x50x8mm, FPM
(50-319241-00)
 **NF634**  80x100x13mm, MVQ
(50-319343-00)
01/76 →



HR378 [37] 
NF541 (x2) [2] 
 **NF814** (x2) [38]

JB855  (x4)
(31-022722-10)

● **PA349**
(33-102290-10)
22x16x2mm

HR300 
HR569 
24-30667-00/0





 **NF786**  45x60x10mm, MVQ
 **NF835**  80x100x8mm, FPM/ACM
(50-319239-00)
 **NF634**  80x100x13mm, MVQ
(50-319343-00)



HR565 [37] 
NF541 (x2) [2] 
 **NF781** (x2) [38]

JB855  (x4)
(31-022722-10)

● **PA349**
(33-102290-10)
22x16x2mm





HR569 
24-30667-00/0

 **NF685**  45x60x10mm, ACM
 **NF835**  80x100x8mm, FPM/ACM
(50-319239-00)

HR565 [37] 
NF541 (x2) [2] 
 **NF781** (x2) [38]

JB855  (x4)
(31-022722-10)

● **PA349**
(33-102290-10)
22x16x2mm

 **NF786**  45x60x10mm, MVQ
 **NF835**  80x100x8mm, FPM/ACM
(50-319239-00)







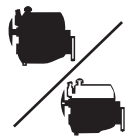



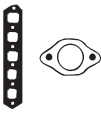

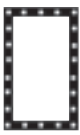

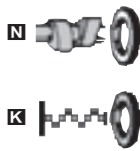











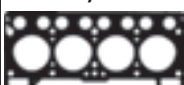



































































HR565 [37] 
NF781 (x2) [38]



KW/PS



R18 2.0L				10/81 → 07/86	205	BG170 (Fibre), 1.20mm (30-027064-10)	DG170	EG176 [36] (22-24777-01/0)
J6R 716	1995	4	88.00	Carburettor	77/105			
R18 2.1L D Diesel				11/81 → 07/86	206	BH080 (Fibre), 1.60mm, 1 Hole (30-024772-10) →0.96mm BG900 (Fibre), 1.70mm (30-024773-10) →0.96 →1.04mm BH090 (Fibre), 1.80mm, 2 Holes (30-024774-10) →1.04mm →	DH080▲ (21-24775-21/0)	EG176 [36] (22-24777-01/0) GH080▲ [36]
852 710/J8S 711	2068	4	86.00		49/67			
R18 2.1L D Diesel				11/80 → 07/86	207	BH080 (Fibre), 1.60mm, 1 Hole (30-024772-10) →0.96mm BG900 (Fibre), 1.70mm (30-024773-10) →0.96 →1.04mm BH090 (Fibre), 1.80mm, 2 Holes (30-024774-10) →1.04mm →	DH080▲ (21-24775-21/0)	EG176 [36] (22-24777-01/0) GH080▲ [36]
R18 Van 2.1L D Diesel				11/81 → 07/86				
852 710/J8S 711	2068	4	86.00		49/67			
R18 2.2L i				06/84 → 07/86	208	BG170 (Fibre), 1.20mm (30-027064-10)	DG173 (21-27064-20/0)	EG176 [36] (22-24777-01/0)
	2165	4			76/103			
R19 1.2L				01/88 → 12/95	209	BH690 (Fibre), 1.20mm (30-024733-10) BM800 (Fibre), 1.75mm [34]	DH693■○ DN684■▲○	EH680 (22-20518-01/0)
R19 Van 1.2L				01/88 → 12/95				
C1G 730	1237	4	71.50	Carburettor	40/54			
R19 1.4L				01/89 → 04/92	210	BH690 (Fibre), 1.20mm (30-024733-10) BM800 (Fibre), 1.75mm [34]	DH693■○ DH699■ DN684■▲○	EH680 (22-20518-01/0)
C3J 710	1397	4	76.00	SPi	43-44/ 58-60			
R19 1.4L				07/88 → 12/95	211	BH690 (Fibre), 1.20mm (30-024733-10) BM800 (Fibre), 1.75mm [34]	DH693■○ DH699■ DN684■▲○	EH680 (22-20518-01/0)
C2J 772 C3J 710	1397 1397	4 4	76.00 76.00	Carburettor SPi	43/58 43-44/ 58-60			
R19 1.4L				01/88 → 12/95	212	BX720 (Fibre), 1.35mm (30-026446-10) BX730 (Fibre), 1.75mm [34]	DS580 (21-26446-22/0) DX720 (21-26446-24/0)	ES580 [36]
E7J 742 E7J 706 E6J 700/E6J 701	1390 1390 1390	4 4 4	75.80 75.80 75.80	SPi SPi Carburettor	55/75 55-59/ 75-80 58-59/ 79-80			

								
HBS116  (22-51006B) M12x1.50x243mm (x10)	JB954 	JN292 (50-024771-00)	JJ558 (Felt) ● PB852 16x24x1.5mm ● PA349 (33-102290-10) 22x16x2mm	HR569  24-30667-00/0	NA5016  35x47x7mm, FPM/ACM (50-305690-50) ● NF687 35x47x7mm, ACM ● NF648  50x68x10mm, MVQ (50-306251-00) ● NF843  50x68x10mm, FPM/ACM (50-305667-70) ● NF844  90x110x11mm, FPM/ACM	HL5014 [245]  NF781 (x2) [38] NF849 [15]	 BG170  BG900  BH080, BH090  BH690  HR351 [37]  NF541 (x2) [2]  Berline NF781 (x2) [38] NF849 [15]	
HBS010  (22-51104B) M12x1.50x247mm (x2) M12x1.50x148mm (x4) M12x1.50x134mm (x8)		JN697 (31-024775-10)	JJ558 (Felt) ● PB852 16x24x1.5mm ● PA349 (33-102290-10) 22x16x2mm	HR569  24-30667-00/0	NA5016  35x47x7mm, FPM/ACM (50-305690-50) ● NF648  50x68x10mm, MVQ (50-306251-00) ● NF843  50x68x10mm, FPM/ACM (50-305667-70) ● NF844  90x110x11mm, FPM/ACM	HL5014 [245]  HR351 [37]  NF541 (x2) [2]  Berline NF781 (x2) [38] NF849 [15]	 BM800  BX720  BX730  JB954  JC669  JC955  JC956  JD245  JN292  JN600  JN697  JN789  JJ407  JJ558	
HBS010  (22-51104B) M12x1.50x247mm (x2) M12x1.50x148mm (x4) M12x1.50x134mm (x8)	JD245	JN697 (31-024775-10)	JJ558 (Felt) ● PB852 16x24x1.5mm ● PA349 (33-102290-10) 22x16x2mm	HR569  24-30667-00/0	NA5016  35x47x7mm, FPM/ACM (50-305690-50) ● NF648  50x68x10mm, MVQ (50-306251-00) ● NF843  50x68x10mm, FPM/ACM (50-305667-70) ● NF844  90x110x11mm, FPM/ACM	HL5014 [245]  HR351 [37]  NF541 (x2) [2]  Berline NF781 (x2) [38] NF849 [15]		
HBS116  (22-51006B) M12x1.50x243mm (x10)	JB954 	JN292 (50-024771-00)	JJ558 (Felt) (Felt) ● PB852 16x24x1.5mm ● PA349 (33-102290-10) 22x16x2mm	HR569  24-30667-00/0	NA5016  35x47x7mm, FPM/ACM (50-305690-50) ● NF648  50x68x10mm, MVQ (50-306251-00) ● NF843  50x68x10mm, FPM/ACM (50-305667-70) ● NF844  90x110x11mm, FPM/ACM	HL5014 [245]  NF781 (x2) [38] NF849 [15]		
HBS104  (22-51005B) M10x1.50x100mm (x10)	JC669 (31-026620-10)	JN600	HC486  ● PA349 (33-102290-10) 22x16x2mm	HR643 	● NF834  35x50x8mm, FPM (50-319241-00) ● NF835  80x100x8mm, FPM/ACM (50-319239-00)	HR378 [37]  NF791 [38]  LT839 [13] JR635 [11]		
HBS104  (22-51005B) M10x1.50x100mm (x10)	JC669 (31-026620-10)	JN600	HC486  ● PA349 (33-102290-10) 22x16x2mm	HR643 	● NF834  35x50x8mm, FPM (50-319241-00) ● NF835  80x100x8mm, FPM/ACM (50-319239-00) ● NF634  80x100x13mm, MVQ (50-319343-00)	HL5015 [245]  HR564 [37]  NF791 [38]  LT839 [13] JR635 [11]		
HBS104  (22-51005B) M10x1.50x100mm (x10)	JC669 (31-026620-10)	JN600	HC486  ● PA349 (33-102290-10) 22x16x2mm	HR643 	● NF834  35x50x8mm, FPM (50-319241-00) ● NF835  80x100x8mm, FPM/ACM (50-319239-00) ● NF634  80x100x13mm, MVQ (50-319343-00)	HR564 [37]  NF791 [38]  LT839 [13] JR635 [11]		
HBS102  (22-51001B) M10x1.50x98mm (x5) M10x1.50x113mm (x5)	JC956  JC955  [133]	JN789 (31-026584-00)	JJ407 ● PA349 (33-102290-10) 22x16x2mm	HR646  24-30670-60/0	● NA5053  30x42x7mm, FPM (50-319488-00) ● NA5016  35x47x7mm, FPM (50-305690-50) ● NF835  80x100x8mm, FPM/ACM (50-319239-00)	HL5015 [245]  HR658 [37]  NF791 [38] 		



KW/PS

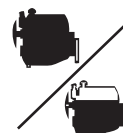

R19 1.7L						07/88 → 12/95	213	BL910 (Fibre), 1.20mm	DL910	EL960 [8]
R19 Cabriolet 1.7L						07/91 → 04/92		(30-026613-00)	DL911	(22-27574-00/0)
F3N 740/F3N 741	1721	4	81.00	SPi			54-55/ 73-75		(21-26613-23/0)	
F2N 712/F2N 728	1721	4	81.00	Carburettor			55/75			
F2N 724	1721	4	81.00	Carburettor			55-56/ 75-76			
F3N 743	1721	4	81.00	MPi			66/89			
F3N 742	1721	4	81.00	MPi			66-70/ 90-95			
F3N 746	1721	4	81.00	MPi			66-80/ 90-109			
R19 Cabriolet 1.7L						04/92 → 09/93	214	BX600 (Fibre)	DX600	EL960 [8]
F3N 743	1721	4	81.00	MPi			66/89	(30-027850-00)	(21-27850-20/0)	(22-27574-00/0)
F3N 742	1721	4	81.00	MPi			66-70/ 90-95			
R19 1.8L						04/92 → 12/95	215	BX600 (Fibre)	DX600	EL960 [8]
R19 Cabriolet 1.8L						04/92 → 06/96		(30-027850-00)	(21-27850-20/0)	(22-27574-00/0)
F3P 682	1783	4	82.70	MPi			79/107			
F3P 704/ F3P 705/ F3P 706/ F3P 707/F3P 708	1794	4	82.70	SPi			65-66/ 88-90			
F3P 760	1794	4	82.70	MPi			65-66/ 88-90			
F3P 764/F3P 765	1794	4	82.70	MPi			79/107			
F3P 700	1794	4	82.70	MPi			79-81/ 107- 110			
R19 1.8L 16V						06/89 → 12/95	216	BX610 (Fibre)	DX610	EL960 [8]
R19 Cabriolet 1.8L 16V						07/91 → 06/96		(30-026980-00)	(21-26980-21/0)	(22-27574-00/0)
F7P 704	1763	4	82.00	MPi			99-101/ 135- 137			
R19 1.9L D Diesel						09/88 → 12/95	217	BS520 (Fibre), 1.65mm, 2 Holes	DL961▲	EL960 [8]
R19 Van 1.9L D Diesel						01/88 → 12/95		(30-026576-10)	(21-26632-21/0)	(22-27574-00/0)
F8Q 706/F8Q 742	1870	4	80.00				47-48/ 64-65	→0.868mm		
								BS530 (Fibre), 1.75mm, 1 Hole		
								(30-026577-10)		
								→0.868 → 1.000mm		
								BS540 (Fibre), 1.85mm, 3 Holes		
								(30-026578-10)		
								→1.000mm →		
R19 1.9L dT Diesel						04/92 → 12/95	218	AY710 (Steel Elastomer), 1.36mm, 2 Holes	DY040▲	EL960 [8]
R19 1.9L TD Diesel						09/90 → 04/92		(30-029016-00)	(21-26632-23/0)	(22-27574-00/0)
R19 Van 1.9L dT Diesel						03/92 → 12/95		→0.073mm		
F8Q 744	1870	4	80.00				66/89	AY720 (Steel Elastomer), 1.44mm, 1 Hole		
F8Q 740	1870	4	80.00				66-68/ 90-93	(30-029017-00)		
								→0.073 → 0.206mm		
								AY730 (Steel Elastomer), 1.52mm, 3 Holes		
								(30-029018-00)		
								→0.206mm →		

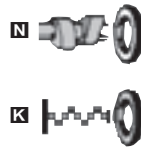
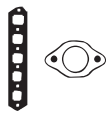

AY710, AY720,
AY730



BL910



BS520, BS530,
BS540



BX600



BX610



JD409



JD410



JD411



JD463



JN732



JN996



JJ557











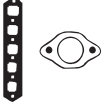

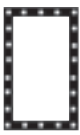

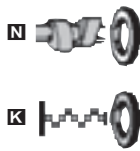











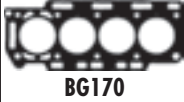



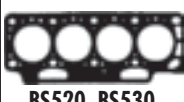











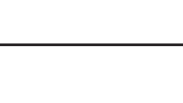













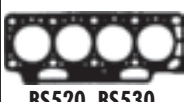

































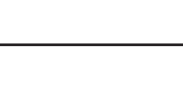



















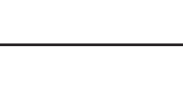

















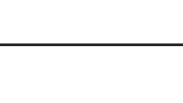









RENAULT



KW/PS

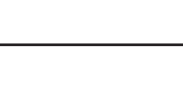

R21 1.4L					06/86 → 10/93	219	BH690 (Fibre), 1.20mm (30-024733-10)		DH693 DH699 DN684	EH680 (22-20518-01/0)
C2J 770	1397	4	76.00	Carburettor		51/69	BM800 (Fibre), 1.75mm [34]			
R21 1.7L					03/86 → 06/94	220	BL910 (Fibre), 1.20mm (30-026613-00)		DL910	EL960 [8] (22-27574-00/0)
R21 Van 1.7L					06/86 → 04/95					
F2N 750	1721	4	81.00	Carburettor		54/73				
F3N 726	1721	4	81.00	SPi		54/73				
F2N 712	1721	4	81.00	Carburettor		55/75				
F2N 752	1721	4	81.00	Carburettor		64/87				
F2N 710	1721	4	81.00	Carburettor		65/88				
F3N 722/F3N 723	1721	4	81.00	MPi		66-70/ 90-95				
R21 1.9L D Diesel					03/86 → 08/94	221	BS520 (Fibre), 1.65mm, 2 Holes (30-026576-10)		DL961	EL960 [8] (22-27574-00/0)
R21 Van 1.9L D Diesel					06/86 → 08/94		BS530 (Fibre), 1.75mm, 1 Hole (30-026577-10) BS540 (Fibre), 1.85mm, 3 Holes (30-026578-10)		(21-26632-21/0)	
F8Q 710	1870	4	80.00			47/64	→ 0.868mm → 0.868 → 1.000mm → 1.000mm →			
R21 2.0L					03/86 → 12/93	222	BG170 (Fibre), 1.20mm (30-027064-10)		DG173	EG176 [36] (22-24777-01/0)
R21 2.0L 4x4					03/89 → 12/93				(21-27064-20/0)	
J6R 758/ J6R 759/ J6R 792/J6R 793	1995	4	88.00	Carburettor		75/102				
J7R 750/J7R 751	1995	4	88.00	MPi		85/116				
J7R 746/J7R 747	1995	4	88.00	MPi		88/120				
R21 2.0L					02/90 → 06/94	223	BX580 (Fibre)		DX580	EG176 [36] (22-24777-01/0)
R21 2.0L 4x4					12/89 → 02/94				(21-27593-20/0)	
J7R 740	1995	4	88.00	MPi		99-100/ 134- 136				
R21 2.0L Turbo					04/87 → 10/92	224	BX590 (Fibre)		DX590	EG176 [36] (22-24777-01/0)
R21 2.0L Turbo 4x4					08/89 → 10/93					
J7R 756	1995	4	88.00			119/162				
J7R 752	1995	4	88.00			129/175				











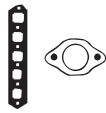

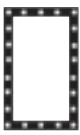

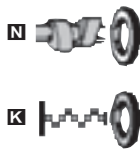





































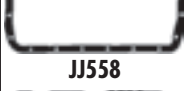













































								
HBS104  (22-51005B) M10x1.50x100mm (x10)	JC669 (31-026620-10)	JN600	HC486  - PA349 (33-102290-10) 22x16x2mm	HR643 	 NF834  35x50x8mm, FPM (50-319241-00)  NF835  80x100x8mm, FPM/ACM (50-319239-00)  NF634  [216] 80x100x13mm, MVQ (50-319343-00)	HR564 [37]  NF791 [38]  LT839 [13] JR635 [11]	 BG170  BH690  BL910  BM800  BS520, BS530, BS540  BX580  BX590  JB954  JC238  JC669  JD409  JD413  JD414  JN292  JN600  JN732  JN995	 JJ557  JJ558  JJ559  JJ562
HBS244  (22-51103B) M12x1.50x111mm (x10)	JD409 (31-026628-10)	JN732 (50-026632-00)	JJ557 - PA349 (33-102290-10) 22x16x2mm	HR569  24-30667-00/0	 NF846  25x42x7mm, FPM/ACM (50-319516-00)  NF843  50x68x10mm, FPM/ACM (50-305667-70)  NF850  85x105x8mm, FPM (50-319183-00)	HL5013 [245]  NF791 [38] KA625 [13] NF849 [15]	 BS520, BS530, BS540  BX580  BX590  JB954  JC238  JC669  JD409  JD413  JD414  JN292  JN600  JN732  JN995	 JJ559  JJ562
HBS244  (22-51103B) M12x1.50x111mm (x10)	JD409 (31-026628-10)	JN732 (50-026632-00)	JJ557 - PA349 (33-102290-10) 22x16x2mm	HR569  24-30667-00/0	 NF846  25x42x7mm, FPM/ACM (50-319516-00)  NF843  50x68x10mm, FPM/ACM (50-305667-70)  NF850  85x105x8mm, FPM (50-319183-00)	HL5013 [245]  NF791 [38] KA625 [13] NF849 [15]	 BX580  BX590  JB954  JC238  JC669  JD409  JD413  JD414  JN292  JN600  JN732  JN995	 JJ559  JJ562
HBS116  (22-51006B) M12x1.50x243mm (x10)	JB954  - JC238 (31-025868-10)	JN292 (50-024771-00)	JJ558 (Felt) JJ559 (Rubber/Metal) - PB852 16x24x1.5mm - PA349 (33-102290-10) 22x16x2mm	HR569  24-30667-00/0	 NA5016  35x47x7mm, FPM/ACM (50-305690-50)  NF843  50x68x10mm, FPM/ACM (50-305667-70)  NF844  90x110x11mm, FPM/ACM	HL5014 [245]  NF781 (x2) [38] NF849 [15]	 JC238  JC669  JD409  JD413  JD414  JN292  JN600  JN732  JN995	 JJ558  JJ559  JJ562
HBS116  (22-51006B) M12x1.50x243mm (x10)	JD414  - JD413 	JN995	JJ562 (Rubber) - PB852 16x24x1.5mm - PA349 (33-102290-10) 22x16x2mm	HR788 	 NB866  28x42x7mm, FPM  NF843  50x68x10mm, FPM/ACM (50-305667-70)  NF844  90x110x11mm, FPM/ACM	NF781 (x2) [38] NF849 [15]	 JD413  JD414  JN292  JN600  JN732  JN995	 JJ562
HBS116  (22-51006B) M12x1.50x243mm (x10)	 JC238 (31-025868-10)	JN994 (50-027601-00)	JJ559 (Rubber/Metal) → Eng.F0020986 2 - PB852 16x24x1.5mm - PA349 (33-102290-10) 22x16x2mm JJ562 (Rubber) Eng.F0020986 →	HR569  24-30667-00/0	 NA5016  35x47x7mm, FPM/ACM (50-305690-50)  NF843  50x68x10mm, FPM/ACM (50-305667-70)  NF844  90x110x11mm, FPM/ACM	HL5014 [245]  NF781 (x2) [38] NF849 [15]	 JD413  JD414  JN292  JN600  JN732  JN995	 JJ559  JJ562



KW/PS



R21 2.1L D Diesel		05/89 → 09/95		225		BH080 (Fibre), 1.60mm, 1 Hole (30-024772-10)		DH080▲ (21-24775-21/0)		EG176 [36] (22-24777-01/0)	
R21 2.1L D 4x4 Diesel		10/88 → 05/92									
R21 2.1L Turbo-D Diesel		03/86 → 06/94				→ +0.96mm				GH080▲ [36]	
R21 Van 2.1L D Diesel		06/86 → 08/94				BG900 (Fibre), 1.70mm (30-024773-10)					
J8S 704	2068	4	86.00		48-49/ 65-67		→ -0.96 → 1.04mm				
J8S 784	2068	4	86.00		51/69		BH090 (Fibre), 1.80mm, 2 Holes (30-024774-10)				
J8S 600/J8S 740	2068	4	86.00		53/72		→ 1.04mm →				
J8S 714/ J8S 786 (KAT)/J8S 788	2068	4	86.00		65/88						
R21 2.2L		06/86 → 06/94		226		BG170 (Fibre), 1.20mm (30-027064-10)		DG173 (21-27064-20/0)		EG176 [36] (22-24777-01/0)	
R21 2.2L 4x4		06/86 → 06/94									
J7T 754/J7T 755	2165	4	88.00	MPi	79/107						
R25 2.0L		04/84 → 12/93		227		BG170 (Fibre), 1.20mm (30-027064-10)		DG173 (21-27064-20/0)		EG176 [36] (22-24777-01/0)	
J6R 706/ J6R 707/ J6R 760/ J6R 762/J6R 763	1995	4	88.00	Carburettor	74/100						
J7R 722/J7R 723	1995	4	88.00	MPi	88/120						
R25 2.0L 12V		06/88 → 12/93		228		BX580 (Fibre)		DX580 (21-27593-20/0)		EG176 [36] (22-24777-01/0)	
J7R 726	1995	4	88.00	MPi	99-100/ 135- 136						
J7R 720/J7R 721	1995	4	88.00	MPi	103/140						
R25 2.1L D Diesel		04/84 → 12/92		229		BH080 (Fibre), 1.60mm, 1 Hole (30-024772-10)		DH080▲ (21-24775-21/0)		EG176 [36] (22-24777-01/0)	
J8S 706	2068	4	86.00		46/63		→ +0.96mm				GH080▲ [36]
J8S 736	2068	4	86.00		51/69		BG900 (Fibre), 1.70mm (30-024773-10)				
							→ -0.96 → 1.04mm				
							BH090 (Fibre), 1.80mm, 2 Holes (30-024774-10)				
							→ 1.04mm →				
R25 2.1L Turbo-D Diesel		04/84 → 12/92		230		BH080 (Fibre), 1.60mm, 1 Hole (30-024772-10)		DH080▲ (21-24775-21/0)		EG176 [36] (22-24777-01/0)	
J8S 708/J8S 738	2068	4	86.00		63/86		→ +0.96mm				GH080▲ [36]
							BG900 (Fibre), 1.70mm (30-024773-10)				
							→ -0.96 → 1.04mm				
							BH090 (Fibre), 1.80mm, 2 Holes (30-024774-10)				
							→ 1.04mm →				







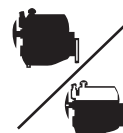



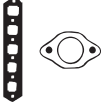

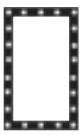

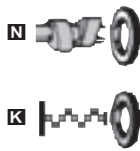

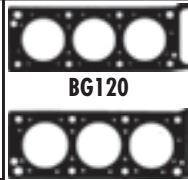























								
HBS010   (22-51104B) M12x1.50x247mm (x2) M12x1.50x148mm (x4) M12x1.50x134mm (x8)	JD245	JN697 (31-024775-10) Clamped injectors JN937 (31-028771-00) Screwed injectors	JJ559 (Rubber/Metal) ● PB852 16x24x1.5mm ● PA349 (33-102290-10) 22x16x2mm	HR569  24-30667-00/0	NA5016 35x47x7mm, FPM/ACM (50-305690-50) NF843  50x68x10mm, FPM/ACM (50-305667-70) NF844  90x110x11mm, FPM/ACM	HL5014 [245]  HR351 [37]  NF781 (x2) [38] NF849 [15]	 BG170  BG900  BH080, BH090  BX580  JB954  JC238  JD245  JD413  JD414  JN292  JN697  JN937  JN995  JJ558  JJ559  JJ562	
HBS116  (22-51006B) M12x1.50x243mm (x10)	JB954  JC238 (31-025868-10)	JN292 (50-024771-00)	JJ562 (Rubber) ● PB852 16x24x1.5mm ● PA349 (33-102290-10) 22x16x2mm	HR569  24-30667-00/0	NA5016 35x47x7mm, FPM/ACM (50-305690-50) NF843  50x68x10mm, FPM/ACM (50-305667-70) NF844  90x110x11mm, FPM/ACM	HL5014 [245]  NF781 (x2) [38] NF849 [15]	 JB954  JC238  JD245  JD413  JD414  JN292  JN697  JN937  JN995  JJ558  JJ559  JJ562	
HBS116  (22-51006B) M12x1.50x243mm (x10)	JB954  JC238 (31-025868-10)	JN292 (50-024771-00)	JJ558 (Felt) (Felt) ● PB852 16x24x1.5mm ● PA349 (33-102290-10) 22x16x2mm	HR569  24-30667-00/0	NA5016 35x47x7mm, FPM/ACM (50-305690-50) NF843  50x68x10mm, FPM/ACM (50-305667-70) NF844  90x110x11mm, FPM/ACM	HL5014 [245]  NF849 [15]	 JD413  JD414  JN292  JN697  JN937  JN995  JJ558  JJ559  JJ562	
HBS116  (22-51006B) M12x1.50x243mm (x10)	JD414  JD413	JN995	JJ562 (Rubber) ● PB852 16x24x1.5mm ● PA349 (33-102290-10) 22x16x2mm	HR788  24-30667-00/0	NB866 28x42x7mm, FPM NF843  50x68x10mm, FPM/ACM (50-305667-70) NF844  90x110x11mm, FPM/ACM	NF849 [15]	 JN697  JN937  JN995  JJ558  JJ559  JJ562	
HBS010   (22-51104B) M12x1.50x247mm (x2) M12x1.50x148mm (x4) M12x1.50x134mm (x8)	JD245	JN697 (31-024775-10) Clamped injectors JN937 (31-028771-00) Screwed injectors	JJ558 (Felt) (Felt) JJ559 (Rubber/Metal) ● PB852 16x24x1.5mm ● PA349 (33-102290-10) 22x16x2mm	HR569  24-30667-00/0	NA5016 35x47x7mm, FPM/ACM (50-305690-50) NF843  50x68x10mm, FPM/ACM (50-305667-70) NF844  90x110x11mm, FPM/ACM	HL5014 [245]  HR351 [37]  NF781 (x2) [38] NF849 [15]	 JN697  JN937  JN995  JJ558  JJ559  JJ562	
HBS010   (22-51104B) M12x1.50x247mm (x2) M12x1.50x148mm (x4) M12x1.50x134mm (x8)	JD245	JN697 (31-024775-10)	JJ559 (Rubber/Metal) → 05/87 → Eng.345498 J85-708 J85-738 ● PB852 16x24x1.5mm ● PA349 (33-102290-10) 22x16x2mm JJ562 (Rubber) 06/87 → Eng.345499 → J85-708	HR569  24-30667-00/0	NA5016 35x47x7mm, FPM/ACM (50-305690-50) NF843  50x68x10mm, FPM/ACM (50-305667-70) NF844  90x110x11mm, FPM/ACM	HL5014 [245]  HR351 [37]  NF781 (x2) [38] NF849 [15]	 JN697  JN937  JN995  JJ558  JJ559  JJ562	



KW/PS



R25 2.2L					04/84 → 12/92	231	BG170 (Fibre), 1.20mm (30-027064-10)	DG173 (21-27064-20/0)	EG176 [36] (22-24777-01/0)
J7T 708/ J7T 732/J7T 733	2165	4	88.00	MPi	79/107				
J7T 706/J7T 707	2165	4	88.00	MPi	89/121				
J7T 714/J7T 715	2165	4	88.00	MPi	89-91/ 121- 124				
J7T 730/J7T 731	2165	4	88.00	MPi	91/124				
R25 2.7L V6 Injection					04/84 → 08/89	232	BG120 (Fibre), 1.20mm		
Z7V 708/ Z7V 709/Z7V 711	2664	6	88.00	MPi	104/141		BG130 (Fibre), 1.20mm		
							(30-024150-10)		
R25 2.8L V6					06/87 → 02/90	233	AG5270 (Fibre)	CG5270	
R25 2.8L V6 Injection					06/86 → 12/92				
Z7W 702	2849	6	91.00	MPi	100/136				
Z7W 709	2849	6	91.00	MPi	110/150				
Z7W 706/Z7W 707	2849	6	91.00	MPi	110- 112/ 150- 153				
Z7W 700	2849	6	91.00	MPi	115/156				
R30 2.1L Turbo-D Diesel					02/82 → 03/86	234	BH080 (Fibre), 1.60mm, 1 Hole (30-024772-10) → 0.96mm	DH080▲ (21-24775-21/0)	EG176 [36] (22-24777-01/0) GH080▲ [36]
J8S 702	2068	4	86.00		63/86		BG900 (Fibre), 1.70mm (30-024773-10) → 0.96 → 1.04mm		
							BH090 (Fibre), 1.80mm, 2 Holes (30-024774-10) → 1.04mm →		
Rapid Van 1.0L					02/86 → 05/92	235	BH680 (Fibre), 1.20mm (30-024764-10)	DH683■○ (21-24764-25/0)	EH680 (22-20518-01/0)
	949	4			27/37		BM790 (Fibre), 1.75mm [34]	DH687■ DN684■▲○	
Rapid Van 1.1L					07/85 → 04/95	236	BH680 (Fibre), 1.20mm (30-024764-10)	DH683■○ (21-24764-25/0)	EH680 (22-20518-01/0)
C1E 756/ C1E 760/C1E 792	1108	4	70.00	Carburettor	33/45		BM790 (Fibre), 1.75mm [34]	DH687■ DN684■▲○	
C1E 750/ C1E 752/C1E 754	1108	4	70.00	Carburettor	33-34/ 45-46				
C1E 762	1108	4	70.00	Carburettor	33-36/ 45-49				
Rapid Van 1.2L					09/91 → 03/98	237	BV190 (Fibre), 1.25mm (30-027575-00)	DV190▲ (21-27577-20/0)	EV190 [36]
C3G 710/C3G 712	1239	4	74.00	SPi	40/54		BX740 (Fibre), 1.75mm [34]	DX651 (21-27575-20/0) contains BV190	
Rapid Van 1.4L					07/85 → 03/98	238	BH690 (Fibre), 1.20mm (30-024733-10)	DH693■○ DH699■ DN684■▲○	EH680 (22-20518-01/0)
C1J 780	1397	4	76.00	Carburettor	43/58		BM800 (Fibre), 1.75mm [34]		
C1J 768	1397	4	76.00	Carburettor	43-44/ 58-60				
C3J 700/ C3J 702/ C3J 760/C3J 762	1397	4	76.00	SPi	43-44/ 58-60				
C2J 784	1397	4	76.00	Carburettor	44/60				







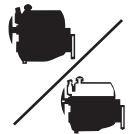

									
HBS116  (22-51006B) M12x1.50x243mm (x10)	JB954 	JN292 (50-024771-00)	JJ559 (Rubber/Metal) →05/87 ● PB852 16x24x1.5mm ● PA349 (33-102290-10) 22x16x2mm JJ562 (Rubber) 06/87→	HR569  24-30667-00/0	NA5016 35x47x7mm, FPM/ACM (50-305690-50) ● NF843 50x68x10mm, FPM/ACM (50-305667-70) ● NF844 90x110x11mm, FPM/ACM	HL5014 [245]  NF849 [15]		BG120 BG130 BG170 BG900 BH080, BH090 BH680, BM790, BH690 BM800 BV190, BX740 JB954 JC669 JD231 JD245 JN292 JN600 JN697 JN936 JJ558 JJ562	JJ562
HBS127  (22-15009B) M12x1.50x178mm (x16)		JN302  (31-026682-00) JN303 	● PA349 (33-102290-10) 22x16x2mm	HR569  (x2) 24-30667-00/0	NF687 35x47x7mm, ACM ● NF761 42x62x10mm, FPM/ACM (50-319355-00) ● NF835 80x100x8mm, FPM/ACM (50-319239-00)			BH080, BH090 BH680, BM790, BH690 BM800 BV190, BX740 JB954 JC669 JD231 JD245 JN292 JN600 JN697 JN936 JJ558 JJ562	
HBS127  (22-15009B) M12x1.50x178mm (x16)		JN302  (31-026682-00) JN303 	● PA349 (33-102290-10) 22x16x2mm	HR569  (x2) 24-30667-00/0	NF687 35x47x7mm, ACM			BH080, BH090 BH680, BM790, BH690 BM800 BV190, BX740 JB954 JC669 JD231 JD245 JN292 JN600 JN697 JN936 JJ558 JJ562	
HBS010   (22-51104B) M12x1.50x247mm (x2) M12x1.50x148mm (x4) M12x1.50x134mm (x8)	JD245	JN697 (31-024775-10)	JJ558 (Felt) (Felt) ● PB852 16x24x1.5mm ● PA349 (33-102290-10) 22x16x2mm	HR569  24-30667-00/0	NA5016 35x47x7mm, FPM/ACM (50-305690-50) ● NF843 50x68x10mm, FPM/ACM (50-305667-70) ● NF844 90x110x11mm, FPM/ACM	HL5014 [245]  HR351 [37]  NF781 (x2) [38] NF849 [15]		BH080, BH090 BH680, BM790, BH690 BM800 BV190, BX740 JB954 JC669 JD231 JD245 JN292 JN600 JN697 JN936 JJ558 JJ562	
HBS104  (22-51005B) M10x1.50x100mm (x10)	JC669 (31-026620-10)	JN600	HC486  ● KJ647 18.3x24x2mm	HR643 	● NF834 35x50x8mm, FPM (50-319241-00) ● NF835 80x100x8mm, FPM/ACM (50-319239-00)	HR350 [37]  NF791 [38] JR635 [11]		BH080, BH090 BH680, BM790, BH690 BM800 BV190, BX740 JB954 JC669 JD231 JD245 JN292 JN600 JN697 JN936 JJ558 JJ562	
HBS104  (22-51005B) M10x1.50x100mm (x10)	JC669 (31-026620-10)	JN600	HC486  ● PA349 (33-102290-10) 22x16x2mm	HR643 	● NF834 35x50x8mm, FPM (50-319241-00) ● NF835 80x100x8mm, FPM/ACM (50-319239-00)	HR350 [37]  NF791 [38] LT839 [13] JR635 [11]		BH080, BH090 BH680, BM790, BH690 BM800 BV190, BX740 JB954 JC669 JD231 JD245 JN292 JN600 JN697 JN936 JJ558 JJ562	
HBS104  (22-51005B) M10x1.50x100mm (x10)	JD231	JN936 (50-027577-00)	HC486  ● PA349 (33-102290-10) 22x16x2mm	HR643 	● NF834 35x50x8mm, FPM (50-319241-00) ● NF835 80x100x8mm, FPM/ACM (50-319239-00)	HT025 [37]  NF791 [38] LT839 [13]		BH080, BH090 BH680, BM790, BH690 BM800 BV190, BX740 JB954 JC669 JD231 JD245 JN292 JN600 JN697 JN936 JJ558 JJ562	
HBS104  (22-51005B) M10x1.50x100mm (x10)	JC669 (31-026620-10)	JN600	HC486  ● PA349 (33-102290-10) 22x16x2mm	HR643 	● NF834 35x50x8mm, FPM (50-319241-00) ● NF835 80x100x8mm, FPM/ACM (50-319239-00)	HR564 [37]  NF791 [38] LT839 [13]		BH080, BH090 BH680, BM790, BH690 BM800 BV190, BX740 JB954 JC669 JD231 JD245 JN292 JN600 JN697 JN936 JJ558 JJ562	

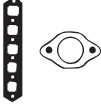

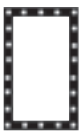
KW/PS

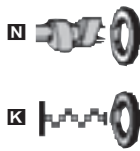

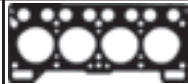
Rapid Van 1.4L				09/91 → 03/98	239	BX720 (Fibre), 1.35mm (30-026446-10) BX730 (Fibre), 1.75mm [34]	DX720 (21-26446-24/0)	ES580 [36]
E7J 720/ E7J 724/ E7J 726/E7J 773 E7J 728	1390	4	75.80	SPi	55-59/ 75-80			
	1390	4	75.80	SPi	58-59/ 79-80			
Rapid Van 1.6L D Diesel				03/86 → 08/98	240	BL960 (Fibre), 1.65mm, 2 Holes [33] (30-026968-10) →03/88 →0.885mm BL970 (Fibre), 1.75mm, 1 Hole (30-026969-10) →03/88 →0.885 → 0.985mm BL980 (Fibre), 1.85mm, 3 Holes →03/88 →0.985mm → BS010 (Fibre), 1.65mm, 2 Holes (30-025301-20) 04/88 → →0.885mm BS020 (Fibre), 1.75mm, 1 Hole (30-025302-20) 04/88 → →0.885 → 0.985mm BS030 (Fibre), 1.85mm, 3 Holes (30-025303-20) 04/88 → →0.985mm →	DL961▲ (21-26632-21/0)	EL960 [8] (22-27574-00/0)
F8M 720/ F8M 730/ F8M 736/F8M 760	1595	4	78.00		40/54			
Rapid Van 1.9L D Diesel				09/91 → 03/98	241	BS520 (Fibre), 1.65mm, 2 Holes (30-026576-10) →0.868mm BS530 (Fibre), 1.75mm, 1 Hole (30-026577-10) →0.868 → 1.000mm BS540 (Fibre), 1.85mm, 3 Holes (30-026578-10) →1.000mm →	DL961▲ (21-26632-21/0)	EL960 [8] (22-27574-00/0)
F8Q 640 F8Q 722/ F8Q 724/ F8Q 774/F8Q 776 F8Q 682	1870	4	80.00		40/54 47-48/ 64-67			
	1870	4	80.00		48/65			
Rodeo 1.1L				11/81 → 12/87	242	BH680 (Fibre), 1.20mm (30-024764-10) BM790 (Fibre), 1.75mm [34]	DH681○ (21-24764-24/0) DH685▲■	EH684 [36] GH683○ [36]
688 12	1108	4	70.00	Carburettor	25/34			
Safrane 2.0L				11/92 → 07/96	243		DX560 (21-28766-20/0)	EG176 [36] (22-24777-01/0)
J7R 732/J7R 733	1995	4	88.00	MPi	77/105			
Safrane 2.0L 12V				04/92 → 07/96	244	BX570 (Fibre) (30-028767-00)	DX570 (21-28767-20/0)	EG176 [36] (22-24777-01/0)
J7R 734/J7R 735	1995	4	88.00	MPi	97-99/ 132- 135			







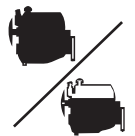



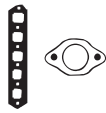

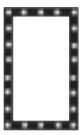

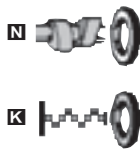











































									
HBS102 Ⓢ (22-51001B) M10x1.50x98mm (x5) M10x1.50x113mm (x5)	JC956 ■ JC955 ■ [133]	JN789 (31-026584-00)	JJ407 PA349 (33-102290-10) 22x16x2mm	HR646 ■ 24-30670-60/0	NA5053 30x42x7mm, FPM (50-319488-00) NA5016 ■ 35x47x7mm, FPM (50-305690-50) NF835 ■ 80x100x8mm, FPM/ACM (50-319239-00)	HL5015 [245]■ HR658 [37]■	BH680, BM790 BL960, BL970, BL980 BS010, BS020, BS030 BS520, BS530, BS540 BX570 BX720 BX730 JB851 JC955 JC956 JD409 JD416 JN248 JN292 JN732 JN789 JN995 HC354	JJ407 JJ557 JJ558 JJ559	
HBS244 Ⓢ (22-51103B) M12x1.50x111mm (x10)	JD409 (31-026628-10)	JN732 (50-026632-00)	JJ557 PA349 (33-102290-10) 22x16x2mm	HR569 ■ 24-30667-00/0	NF846 25x42x7mm, FPM/ACM (50-319516-00) NF843 ■ 50x68x10mm, FPM/ACM (50-305667-70) NF850 ■ 85x105x8mm, FPM (50-319183-00)	HL5013 [245]■ NF791 [38] KA625 [13] NF849 [15]	BS520, BS530, BS540 BX570 BX720 BX730 JB851 JC955 JC956 JD409 JD416 JN248 JN292 JN732 JN789 JN995 HC354	JJ557 JJ558 JJ559	
HBS244 Ⓢ (22-51103B) M12x1.50x111mm (x10)	JD409 (31-026628-10)	JN732 (50-026632-00)	JJ557 PA349 (33-102290-10) 22x16x2mm	HR569 ■ 24-30667-00/0	NF846 25x42x7mm, FPM/ACM (50-319516-00) NF843 ■ 50x68x10mm, FPM/ACM (50-305667-70) NF850 ■ 85x105x8mm, FPM (50-319183-00)	HL5013 [245]■ NF791 [38] KA625 [13] NF849 [15]	BS520, BS530, BS540 BX570 BX720 BX730 JB851 JC955 JC956 JD409 JD416 JN248 JN292 JN732 JN789 JN995 HC354	JJ557 JJ558 JJ559	
HBS104 Ⓢ (22-51005B) M10x1.50x100mm (x10)	JB851 (31-022715-10)	JN248 (50-026305-00)	HC354 ■ KJ647 18.3x24x2mm		NF535 30x42x8mm, NBR NF834 ■ 35x50x8mm, FPM (50-319241-00) NF835 ■ 80x100x8mm, FPM/ACM (50-319239-00)	HR350 [37]■ KA533 [13] JR635 [11]	BS520, BS530, BS540 BX570 BX720 BX730 JB851 JC955 JC956 JD409 JD416 JN248 JN292 JN732 JN789 JN995 HC354	JJ557 JJ558 JJ559	
HBS116 Ⓢ (22-51006B) M12x1.50x243mm (x10)		JN292 (50-024771-00)	JJ558 (Felt) JJ559 (Rubber/Metal) PB852 16x24x1.5mm PA349 (33-102290-10) 22x16x2mm	HR569 ■ 24-30667-00/0	NA5016 35x47x7mm, FPM/ACM (50-305690-50) NF843 ■ 50x68x10mm, FPM/ACM (50-305667-70) NF844 ■ 90x110x11mm, FPM/ACM	HL5014 [245]■ NF849 [15]	BS520, BS530, BS540 BX570 BX720 BX730 JB851 JC955 JC956 JD409 JD416 JN248 JN292 JN732 JN789 JN995 HC354	JJ557 JJ558 JJ559	
HBS302 Ⓢ (22-51106B) M12x1.50x204mm (x10)	JD416 ■ (31-028770-00)	JN995	PB852 16x24x1.5mm PA349 (33-102290-10) 22x16x2mm	HR788 ■	NB866 28x42x7mm, FPM NF843 ■ 50x68x10mm, FPM/ACM (50-305667-70) NF844 ■ 90x110x11mm, FPM/ACM	NF849 [15]	BS520, BS530, BS540 BX570 BX720 BX730 JB851 JC955 JC956 JD409 JD416 JN248 JN292 JN732 JN789 JN995 HC354	JJ557 JJ558 JJ559	



KW/PS



Safrane 2.0L 16V					07/96 → 12/00	245	BX650 (Fibre) (30-027376-10)	DX652 (21-27376-21/0)	EA5620 (22-27376-00/0)
N7Q 710/N7Q 711	1948	4	83.00	MPi		100/136			
Safrane 2.1L dT Diesel					11/93 → 07/96	246	BH080 (Fibre), 1.60mm, 1 Hole (30-024772-10) → 0.96mm BG900 (Fibre), 1.70mm (30-024773-10) → 0.96 → 1.04mm BH090 (Fibre), 1.80mm, 2 Holes (30-024774-10) → 1.04mm →	DH080▲ (21-24775-21/0)	EG176 [36] (22-24777-01/0)
J8S 760	2068	4	86.00			65-66/ 88-90			
Safrane 2.2L					04/92 → 07/96	247		DX560 (21-28766-20/0)	EG176 [36] (22-24777-01/0)
J7T 762	2165	4	88.00	MPi		79-81/ 107- 110			
Safrane 2.2L					04/92 → 07/96	248	BX570 (Fibre) (30-028767-00)	DX570 (21-28767-20/0)	EG176 [36] (22-24777-01/0)
J7T 760/J7T 761	2165	4	88.00	MPi		101/137			
Safrane 2.2L dT Diesel					07/96 → 12/00	249	AD5190 (Fibre) (30-029783-00)	CD5190 (21-29783-20/0)	EY070
G8T 740	2188	4	87.00			83/113			
Safrane 2.5L dT Diesel					12/92 → 07/96	250	AY290 (Fibre), 1.60mm [112] (30-027426-00) AY300 (Fibre), 1.70mm [112] (30-026654-20) AY310 (Fibre), 1.80mm [112] (30-026655-20)	DT752▲ (21-28648-20/0)	ET750 [12]
S8U 762 S8U 763	2445 2499	4 4	93.00 93.00			85/115 83/113			
Safrane 2.9L 24V					03/99 → 12/00	251	AG9710 (MLS), 1.40mm ◀ AG9720 (MLS), 1.65mm ◀ AG9730 (MLS), 1.40mm ▶ AG9740 (MLS), 1.65mm ▶	CG9710 CG9720◀ CG9740▶	EG9710
L7X 713	2946	6	87.00	MPi		140/190			
Scénic 1.4L 16V					09/99 → 08/03	252	AC5100 (MLS), 1.20mm (30-029743-00)	CC5100 (21-29743-20/0)	
K4J 714/K4J 750 K4J 730	1390 1390	4 4	79.50 79.50	MPi MPi		70/95 72/98			
Scénic 1.5L dCi Diesel					06/03 →	253	AE5200 (MLS) (30-029015-00) → 05/04 AG9490 (MLS) (30-029497-00) 05/04 →	CE5200▲ (21-29015-20/0) → 09/03	EE5200
K9K 722	1461	4	76.00			60/81			

								
HBS178  (22-51009B) M12x1.75x157mm (x10)	JA5039  (31-029601-00) JA5040  (31-028657-00)		KJ647 18.3x24x2mm	HR5060  (24-30676-75/0)	NA5136 30x47x7mm, NBR (50-319470-00) NA5138 44.5x57.2x6.75mm, FPM (50-319352-00) NA5018  35x47x5.6mm, FPM NA5017  98x110x8.5mm, FPM (50-319354-00)			AC5100 AD5190 AE5200 AY290, AY300, AY310 BG900 BH080, BH090 BX570 BX650 JA5039 JA5040 JC054 JC055 JD245 JD416 JD435 JN292 JN937 JN969 JN995 JJ549 JJ558 JJ559 JJ568 JJ569 JJ595 NA5215 28x42x5mm, FPM NA5016  35x47x7mm, FPM (50-305690-50) NF835  80x100x8mm, FPM/ACM (50-319239-00) NA5215 28x42x5mm, FPM NA5255  35x47x7mm
HBS010   (22-51104B) M12x1.50x247mm (x2) M12x1.50x148mm (x4) M12x1.50x134mm (x8)	JD245	JN937 (31-028771-00)	PB852 16x24x1.5mm PA349 (33-102290-10) 22x16x2mm	HR569  24-30667-00/0	NA5016 35x47x7mm, FPM/ACM (50-305690-50) NF843  50x68x10mm, FPM/ACM (50-305667-70) NF844  90x110x11mm, FPM/ACM	HL5014 [245]  HR351 [37]  NF849 [15]		AY290, AY300, AY310 BH080, BH090 BX570 BX650 JA5039 JA5040 JC054 JC055 JD245 JD416 JD435 JN292 JN937 JN969 JN995 JJ549 JJ558 JJ559 JJ568 JJ569 JJ595
HBS302  (22-51106B) M12x1.50x204mm (x10)		JN292 (50-024771-00)	JJ558 (Felt) JJ559 (Rubber/Metal) PB852 16x24x1.5mm PA349 (33-102290-10) 22x16x2mm	HR569  24-30667-00/0	NA5016 35x47x7mm, FPM/ACM (50-305690-50) NF843  50x68x10mm, FPM/ACM (50-305667-70) NF844  90x110x11mm, FPM/ACM	HL5014 [245]  NF849 [15]		AY290, AY300, AY310 BH080, BH090 BX570 BX650 JA5039 JA5040 JC054 JC055 JD245 JD416 JD435 JN292 JN937 JN969 JN995 JJ549 JJ558 JJ559 JJ568 JJ569 JJ595
HBS302  (22-51106B) M12x1.50x204mm (x10)	JD416  (31-028770-00)	JN995	PB852 16x24x1.5mm PA349 (33-102290-10) 22x16x2mm	HR788 	NB866 28x42x7mm, FPM NF843  50x68x10mm, FPM/ACM (50-305667-70) NF844  90x110x11mm, FPM/ACM	NF849 [15]		AY290, AY300, AY310 BH080, BH090 BX570 BX650 JA5039 JA5040 JC054 JC055 JD245 JD416 JD435 JN292 JN937 JN969 JN995 JJ549 JJ558 JJ559 JJ568 JJ569 JJ595
HBS119   (22-51010B) M11x1.50x207.5mm (x4) M11x1.50x185mm (x5) M11x1.50x103mm (x4) M11x1.50x185mm (x5)	JD435 	JP006 (50-028939-00)	JJ568 (31-028942-00) PA349 (33-102290-10) 22x16x2mm	HR788 	NF858 33x43x6mm, FPM/ACM NF861  46x59x7mm, FPM NF860  93x108x7mm, FPM	HL5023 [245] 		AY290, AY300, AY310 BH080, BH090 BX570 BX650 JA5039 JA5040 JC054 JC055 JD245 JD416 JD435 JN292 JN937 JN969 JN995 JJ549 JJ558 JJ559 JJ568 JJ569 JJ595
HBS011  (22-51004B) M12x1.25x160mm (x10) M12x1.25x119mm (x12)	JC054  (x4) (31-024274-10) JC055  (x4) (31-025031-10)	JN969 (50-027678-00)	JJ549 (31-028788-00) PB853 22x28x3mm					AY290, AY300, AY310 BH080, BH090 BX570 BX650 JA5039 JA5040 JC054 JC055 JD245 JD416 JD435 JN292 JN937 JN969 JN995 JJ549 JJ558 JJ559 JJ568 JJ569 JJ595
HBS272  (22-53016B) M10x1.50x147mm (x16)	JD5879  JD5880  (Steel Elastomer) JD5878  (MLS)		PA349 (33-102290-10) 22x16x2mm		NA5260 38x50x6mm			AY290, AY300, AY310 BH080, BH090 BX570 BX650 JA5039 JA5040 JC054 JC055 JD245 JD416 JD435 JN292 JN937 JN969 JN995 JJ549 JJ558 JJ559 JJ568 JJ569 JJ595
HBS301  (22-51107B) M10x1.50x117mm (x10)	JD5393  JD5893  (FPM) JD5394 	HR397 [57] 34-000410-00	JH5108	PA5013 (x16)	NA5215 28x42x5mm, FPM NA5016  35x47x7mm, FPM (50-305690-50) NF835  80x100x8mm, FPM/ACM (50-319239-00)	HL5029 [245] 		AY290, AY300, AY310 BH080, BH090 BX570 BX650 JA5039 JA5040 JC054 JC055 JD245 JD416 JD435 JN292 JN937 JN969 JN995 JJ549 JJ558 JJ559 JJ568 JJ569 JJ595
HBS299  (22-29019B) M11x1.50x125.0mm (x10)	JD5402  (31-030008-00)  KK5643 (31-030009-00)	JM7054 (NBR)		HR817  24-30614-78/0	NA5215 28x42x5mm, FPM NA5255  35x47x7mm	HL5026 [245] 		AY290, AY300, AY310 BH080, BH090 BX570 BX650 JA5039 JA5040 JC054 JC055 JD245 JD416 JD435 JN292 JN937 JN969 JN995 JJ549 JJ558 JJ559 JJ568 JJ569 JJ595



KW/PS

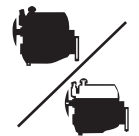

Scénic 1.5L dCi Diesel		11/03 →		254	AE5200 (MLS) (30-029015-00) →05/04 AG9490 (MLS) (30-029497-00) 05/04 →		EE5200
K9K 728/K9K 729	1461	4	76.00	74/101			
Scénic 1.5L dCi Diesel		05/05 →		255	AG9490 (MLS) (30-029497-00)		EE5200
K9K 722	1461	4	76.00	60/81	Direct Injection, SOHC		
K9K 724	1461	4	76.00	63/86			
K9K 729	1461	4	76.00	74/101			
Scénic 1.5L dCi Diesel		05/05 →		256	AG9490 (MLS) (30-029497-00)		EE5200
K9K 732	1461	4	76.00	78/106	Direct Injection, SOHC		
Scénic 1.6L		03/01 →08/03		257	AC5100 (MLS) , 1.20mm (30-029743-00)	CC5100 (21-29743-20/0)	
K4M 709	1598	4	79.50	79/107	Injection, DOHC		
K4M 708	1598	4	79.50	79/81/ 107/ 109	MPi		
K4M 761/K4M 782	1598	4	79.50	83/113	MPi		
Scénic 1.6L 16V		09/99 →08/03		258	AC5100 (MLS) , 1.20mm (30-029743-00)	CC5100 (21-29743-20/0)	
K4M 700/ K4M 701/ K4M 704/K4M 708	1598	4	79.50	79/81/ 107/ 109	MPi		
Scénic 1.8L 16V		01/01 →08/03		259	AD5990 (MLS) (30-029781-00)	CD5991	ED5991
F4P 720/F4P 722	1783	4	82.70	85/115	MPi		
Scénic 1.9L D Diesel		06/06 →		260	AC5061 (MLS) , 1.32mm (30-029473-10)		EC5060 (22-29474-00/0) EC5061
F9Q 812	1870	4	80.00	88/120	Direct Injection, SOHC		
Scénic 1.9L dCi Diesel		11/00 →08/03		261	AC5061 (MLS) , 1.32mm (30-029473-10)	CC5060▲ (21-29483-20/0)	EC5060 (22-29474-00/0)
Scénic 1.9L dCi RX4 Diesel		11/00 →08/03					
F9Q 732/F9Q 740	1870	4	80.00	72/98			
F9Q 733	1870	4	80.00	79-88/ 107- 120			
Scénic 1.9L dCi Diesel		06/03 →		262	AC5061 (MLS) , 1.32mm (30-029473-10)	CC5060▲ (21-29483-20/0)	EC5060 (22-29474-00/0) EC5061
F9Q 812	1870	4	80.00	88/120	Direct Injection, SOHC		
F9Q 803	1870	4	80.00	96/131	Direct Injection, SOHC		
F9Q 804	1870	4	80.00		Direct Injection, SOHC		
Scénic 1.9L dTi Diesel		09/99 →08/03		263	AC5070 (Fibre) , 1.35mm, 2 Notches (30-029474-00) →0.653mm AC5080 (Fibre) , 1.45mm, 1 Notch (30-029475-00) →0.653 →0.786mm AC5090 (Fibre) , 1.55mm, 3 Notches (30-029476-00) →0.786mm →	CC5060▲ (21-29483-20/0)	EC5060 (22-29474-00/0)
F9Q 744	1870	4	80.00	59/80			
F9Q 731/ F9Q 734/F9Q 736	1870	4	80.00	72/98			
Scénic 2.0L dCi Diesel		09/05 →		264	AG9760 (MLS)	CG9760	EG9760
M9R 700	1995	4	84.00	110/150	Direct Injection, DOHC		

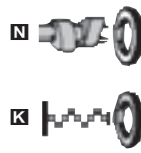
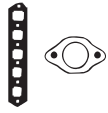

AC5070, AC5080,
AC5090



AC5100



AE5200



JJ557







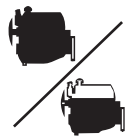



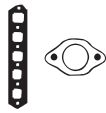

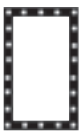

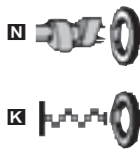

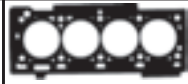











































































HBS299 Ⓢ (22-29019B) M11x1.50x125.0mm (x10)	JD5402 Ⓢ (31-030008-00) Ⓢ KK5643 (31-030009-00)	JM7054 (NBR)	JH5109	HR817 Ⓢ 24-30614-78/0	NA5215 28x42x5mm, FPM NA5255 Ⓢ 35x47x7mm	HL5026 [245]Ⓢ
HBS299 Ⓢ (22-29019B) M11x1.50x125.0mm (x10)	JD5402 Ⓢ (31-030008-00)	JM7054 (NBR)	JH5109 (NBR)	HR817 Ⓢ 24-30614-78/0	NA5215 28x42x5mm, FPM NA5255 Ⓢ 35x47x7mm	HL5026 [245]Ⓢ
HBS299 Ⓢ (22-29019B) M11x1.50x125.0mm (x10)	JD5402 Ⓢ (31-030008-00)	JM7054 (NBR)	JH5109 (NBR)	HR817 Ⓢ 24-30614-78/0	NA5215 28x42x5mm, FPM NA5255 Ⓢ 35x47x7mm	HL5026 [245]Ⓢ
HBS301 Ⓢ (22-51107B) M10x1.50x117mm (x10)	JD5393 Ⓢ JD5894 Ⓢ Ⓢ JE5063	HR397 [57] 34-000410-00	JH5108 ● PA349 (33-102290-10) 22x16x2mm		NA5215 (x2) 28x42x5mm, FPM NA5016 Ⓢ 35x47x7mm, FPM (50-305690-50) NF835 Ⓢ 80x100x8mm, FPM/ACM (50-319239-00)	HL5029 [245]Ⓢ
HBS301 Ⓢ (22-51107B) M10x1.50x117mm (x10)	JD5393 Ⓢ	HR397 [57] 34-000410-00	JH5108 ● PA349 (33-102290-10) 22x16x2mm		NA5215 (x2) 28x42x5mm, FPM NA5016 Ⓢ 35x47x7mm, FPM (50-305690-50) NF835 Ⓢ 80x100x8mm, FPM/ACM (50-319239-00)	HL5029 [245]Ⓢ
HBS310 Ⓢ (22-51108B) M12x1.50x117mm (x10)	JD5908 Ⓢ JD5910 Ⓢ	HR397 [57] 34-000410-00	● PA349 (33-102290-10) 22x16x2mm	PA5013 (x16)	NA5257 28x47x5.5mm NA5036 Ⓢ 42x54x6mm, FPM (50-319473-00) NF850 Ⓢ 85x105x8mm, FPM (50-319183-00)	
HBS372 Ⓢ (22-51109B) M12x1.50x121mm (x10)	JD5890 (MLS) Ⓢ JE5061 (MLS) Ⓢ JE5062 (MLS)	JM5086	JH5041 ● KG5012 16x23x1.5mm	HR646 Ⓢ 24-30670-60/0	NF846 25x42x7mm, FPM/ACM (50-319516-00) NA5036 Ⓢ 42x54x6mm, FPM (50-319473-00) NF850 Ⓢ 85x105x8mm, FPM (50-319183-00)	HL5017 [245]Ⓢ
HBS372 Ⓢ (22-51109B) M12x1.50x121mm (x10)	JD5189	JM5086	● KG5012 16x23x1.5mm	HR646 Ⓢ 24-30670-60/0	NF846 25x42x7mm, FPM/ACM (50-319516-00) NA5036 Ⓢ 42x54x6mm, FPM (50-319473-00) NF850 Ⓢ 85x105x8mm, FPM (50-319183-00)	HL5017 [245]Ⓢ
HBS372 Ⓢ (22-51109B) M12x1.50x121mm (x10)	JD5189 JD5890 (MLS) Ⓢ JE5061 (MLS) Ⓢ JE5062 (MLS)	JM5086	JH5041 ● KG5012 16x23x1.5mm	HR646 Ⓢ 24-30670-60/0	NF846 25x42x7mm, FPM/ACM (50-319516-00) NA5036 Ⓢ 42x54x6mm, FPM (50-319473-00) NF850 Ⓢ 85x105x8mm, FPM (50-319183-00)	HL5017 [245]Ⓢ
HBS120 Ⓢ (22-51008B) M12x1.50x118mm (x10)	JD5189	JM5086	JJ557 ● KG5012 16x23x1.5mm	HR646 Ⓢ 24-30670-60/0	NF846 25x42x7mm, FPM/ACM (50-319516-00) NF843 Ⓢ 50x68x10mm, FPM/ACM (50-305667-70) NF850 Ⓢ 85x105x8mm, FPM (50-319183-00)	
	JD5895 Ⓢ (Steel Elastomer)	HM5291 Ⓢ				



KW/PS



Scénic 2.0L 06/03 → 265						AD5990 (MLS) (30-029781-00)	CD5991	ED5991
Scénic 2.0L 16V 07/00 → 08/03								
Scénic 2.0L 16V IDE 09/99 → 08/03								
Scénic 2.0L 16V RX4 06/00 → 08/03								
F4R 770/F4R 771	1998	4	82.70	MPi	99/135			
F4R 740/	1998	4	82.70	MPi	102/139			
F4R 741/F4R 744								
Scénic 2.0L 16V Turbo 05/04 → 266						AE5110 (MLS) (30-029811-00)	CE5110 (21-29811-20/0)	EE5110 (22-29811-00/0)
F4R 776 1998 4 82.70 MPi, DOHC 120/163								
Sport Spider 2.0L 16V 03/95 → 10/99 267						AD5990 (MLS) (30-029781-00)		EL960 [8] (22-27574-00/0)
F7R 710 1998 4 82.70 MPi 108-110/147-150								
Thalia 1.4L 08/00 → 268						BY030 (Fibre) (30-028797-00)	DX630 (21-28934-20/0)	EA140 (22-28935-00/0)
K7J700 1390 4 79.50 MPi 55/75								
Thalia 1.4L 16V 08/00 → 269						AC5100 (MLS), 1.20mm (30-029743-00)	CC5100 (21-29743-20/0)	
K4J 712 1390 4 79.50 MPi 70-72/95-98								
Thalia 1.5L dCi Diesel 06/01 → 270						AE5200 (MLS) (30-029015-00) → 05/04 AG9490 (MLS) (30-029497-00) 05/04 →	CE5200▲ (21-29015-20/0) → 09/03	EE5200
K9K 700 1461 4 76.00 48/65 K9K 702 1461 4 76.00 60/81								
Thalia 1.5L dCi Diesel 02/03 → 271						AE5200 (MLS) (30-029015-00) → 05/04 AG9490 (MLS) (30-029497-00) 05/04 →	CE5200▲ (21-29015-20/0) → 09/03	EE5200
K9K 714 1461 4 76.00 Direct Injection 50/68 K9K 760/K9K 762 1461 4 76.00 Direct Injection, SOHC 50/68 K9K 768/ 1461 4 76.00 50/68 K9K 792/K9K 840 50/68								
Thalia 1.5L dCi Diesel 06/01 → 10/03 272						AE5200 (MLS) (30-029015-00)	CE5200▲ (21-29015-20/0)	EE5200
K9K 702 1461 4 76.00 60/81 K9K 740 1461 4 76.00 Direct Injection								
Thalia 1.6L 16V 04/02 → 273						AC5100 (MLS), 1.20mm (30-029743-00)	CC5100 (21-29743-20/0)	
K4M 740 1598 4 79.50 MPi 79/107								
Thalia 2.0L 09/01 → 274						AG9320 (MLS) (30-030286-00)		
F4R 738 1998 4 82.70 Injection, DOHC 132-124/180-168								

								 AC5100	 AE5200	 BY030	 JD410	 JD411	 JD420	 JD421	 JN996	 JN997	 JJ565
HBS310  (22-51108B) M12x1.50x117mm (x10)	JD5908  JD5910 	HR397 [57] 34-000410-00	JH5041 ● KG5012 16x23x1.5mm	PA5013 (x16)	 NA5257 28x47x5.5mm  NA5036  42x54x6mm, FPM (50-319473-00)  NF850  85x105x8mm, FPM (50-319183-00)	HL5039 [245] 											
HBS310  (22-51108B) M12x1.50x117mm (x10)	JD5911  JD5910 	HR397 [57] 34-000410-00	JH5041 ● KG5012 16x23x1.5mm	PA5013 (x16)	 NA5257 28x47x5.5mm  NA5036  42x54x6mm, FPM (50-319473-00)  NF850  85x105x8mm, FPM (50-319183-00)	HL5039 [245] 											
HBS177  (22-51003B) M12x1.50x108mm (x10)	JD411  (31-026592-10) JD410  (31-026593-10)	JN996 12/90 →	● PB852 16x24x1.5mm ● PA349 (33-102290-10) 22x16x2mm	HR646  (x2) 24-30670-60/0	 NF846 25x42x7mm, FPM/ACM (50-319516-00)  NF843  50x68x10mm, FPM/ACM (50-305667-70)  NF850  85x105x8mm, FPM (50-319183-00)	HL5013 [245]  KA625 [13] NF849 [15]											
HBS241  (22-51102B) M9x1.25x103mm (x10)	JD421  JD420 	JN997 →01/00 JM5131 (50-029881-00) 01/00 →	JJ565 ● PA349 (33-102290-10) 22x16x2mm	HR789 	 NA5053 30x42x7mm, FPM (50-319488-00)  NF856  32x44x6mm, FPM/ACM	NF791 [38]											
HBS301  (22-51107B) M10x1.50x117mm (x10)	JD5393  JD5893  (FPM) JD5394 	HR397 [57] 34-000410-00	JH5108	PA5013 (x16)	 NA5215 28x42x5mm, FPM  NA5016  35x47x7mm, FPM (50-305690-50)  NF835  80x100x8mm, FPM/ACM (50-319239-00)	HL5029 [245] 											
HBS299  (22-29019B) M11x1.50x125.0mm (x10)	JD5402  (31-030008-00) ● KK5643 (31-030009-00)	JM7054 (NBR)	JH5109 (NBR)	HR817  24-30614-78/0	 NA5215 28x42x5mm, FPM  NA5255  35x47x7mm	HL5026 [245] 											
HBS299  (22-29019B) M11x1.50x125.0mm (x10)	JD5402  (31-030008-00)	JM7054 (NBR)	JH5109 (NBR)	HR817  24-30614-78/0	 NA5215 28x42x5mm, FPM  NA5255  35x47x7mm	HL5026 [245] 											
HBS299  (22-29019B) M11x1.50x125.0mm (x10)	JD5402  (31-030008-00)	JM7054 (NBR)	JH5109 (NBR)	HR817  24-30614-78/0	 NA5215 28x42x5mm, FPM  NA5255  35x47x7mm	HL5026 [245] 											
HBS301  (22-51107B) M10x1.50x117mm (x10)	JD5393 	HR397 [57] 34-000410-00	JH5108		 NA5215 (x2) 28x42x5mm, FPM  NA5016  35x47x7mm, FPM (50-305690-50)  NF835  80x100x8mm, FPM/ACM (50-319239-00)	HL5029 [245] 											
	JD5908  JD5910 				 NA5257 28x47x5.5mm												

RENAULT



KW/PS



Model					Year	Power (KW/PS)	Engine Details	Accessories	Options
Thalia 3.0L V6 Turbo Sport					06/02 →	275	AH5060 (MLS), 0.74mm AH5070 (MLS), 0.95mm AH5040 (MLS), 0.74mm AH5050 (MLS), 0.95mm	CH5060 CH5040	
L7X 762	2946	6	87.00	MPI		187/254			
Trafic 1.4L					03/80 → 04/89	276	BH690 (Fibre), 1.20mm (30-024733-10) BM800 (Fibre), 1.75mm [34]	DH690	[36] [36] (20-24733-03/0) [36]
C1J 700	1397	4	76.00	Carburettor		35-36/ 48-50			
847 700/847 701	1397	4	76.00	Carburettor		47/64			
Trafic 1.4L					05/89 → 06/91	277	BH690 (Fibre), 1.20mm (30-024733-10) BM800 (Fibre), 1.75mm [34]	DH690	[36] [36] (20-24733-03/0) [36]
C1J 700	1397	4	76.00	Carburettor		35-36/ 48-50			
Trafic 1.6L					03/80 → 06/86	278		DF873	[36] [36]
Trafic 1.6L 4x4					03/80 → 08/86				
ATM 705	1647	4	79.00	Carburettor		48/65			
841 705/ ATM 707/ATM 708	1647	4	79.00	Carburettor		48-49/ 65-67			
Trafic 1.7L					06/86 → 08/94	279	BL910 (Fibre), 1.20mm (30-026613-00)	DL910 DL911 (21-26613-23/0)	[8] (22-27574-00/0)
F1N 720/ F1N 722/F1N 724	1721	4	81.00	Carburettor		50/68			
Trafic 1.9L D Diesel					06/97 → 03/01	280	AD5030 (Fibre), 1.4mm, 2 Holes (30-029749-00) AD5040 (Fibre), 1.50mm, 1 Hole (30-029750-00) AD5050 (Fibre), 1.60mm, 3 Holes (30-029751-00)	DL961 (21-26632-21/0)	 (22-29474-00/0)
F8Q 606	1870	4	80.00			40/54			
Trafic 1.9L dCi 100 Diesel					03/01 →	281	AC5061 (MLS), 1.32mm (30-029473-10)	CC5060 (21-29483-20/0)	 (22-29474-00/0)
Trafic 1.9L dCi 80 Diesel					03/01 →				
F9Q 762	1870	4	80.00			60/81			
F9Q 760	1870	4	80.00			74/100			
Trafic 2.0L dCi 115 Diesel					08/06 →	282	AG9760 (MLS)	CG9760	
Trafic 2.0L dCi 90 Diesel					08/06 →				
M9R 780	1995	4	84.00	Direct Injection, DOHC		84-66/ 114-90			
Trafic 2.0L 16V					08/06 →	283	AG9320 (MLS) (30-030286-00)		
F4R 820	1998	4	82.70	Injection, DOHC					
Trafic 2.0L					03/80 → 10/97	284	BG170 (Fibre), 1.20mm (30-027064-10)	DG173 (21-27064-20/0)	[36] (22-24777-01/0)
Trafic 2.0L 4x4					06/86 → 04/89				
J5R 722/J5R 726	1995	4	88.00	Carburettor		59/80			
J5R 716	1995	4	88.00	Carburettor		59-62/ 80-84			
829 720/829 721	1995	4	88.00	Carburettor		63/86			

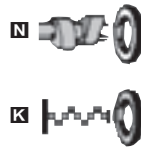
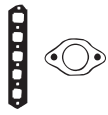

BG170

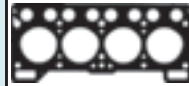

BH690



BL910



BM800



JB954



JB997



JC386



JD409



JN292



JN600



JN732



HC354



JJ558



JJ558



JJ558

JD5906 ■
JD5907 ■ (x2)
JE5069
JE5070
JE5071

HBS104 ⊕
(22-51005B)
M10x1.50x100mm (x10)

JB997

JN600

HC354 ■
PA349
(33-102290-10)
22x16x2mm

HR643 ■

NF834 ■ 35x50x8mm, FPM
(50-319241-00)
NF722 ■ 35x50x10mm, MVQ
NF835 ■ 80x100x8mm, FPM/ACM
(50-319239-00)
NF634 ■ 80x100x13mm, MVQ
(50-319343-00)

HR564 [37] ■

HBS104 ⊕
(22-51005B)
M10x1.50x100mm (x10)

JB997

JN600

HC354 ■
PA349
(33-102290-10)
22x16x2mm

HR643 ■

NF834 ■ 35x50x8mm, FPM
(50-319241-00)
NF835 ■ 80x100x8mm, FPM/ACM
(50-319239-00)
NF634 ■ 80x100x13mm, MVQ
(50-319343-00)

HR564 [37] ■

JC386
(31-025062-10)

PA349
(33-102290-10)
22x16x2mm

HR569 ■
24-30667-00/0

NF685 ■ 45x60x10mm, ACM
NF835 ■ 80x100x8mm, FPM/ACM
(50-319239-00)

HR565 [37] ■

HBS244 ⊕
(22-51103B)
M12x1.50x111mm (x10)

JD409
(31-026628-10)

JN732
(50-026632-00)

PA349
(33-102290-10)
22x16x2mm

HR569 ■
24-30667-00/0

NF846 25x42x7mm, FPM/ACM
(50-319516-00)
NF847 22x45x7mm, FPM/ACM
NF843 ■ 50x68x10mm, FPM/ACM
(50-305667-70)
NF850 ■ 85x105x8mm, FPM
(50-319183-00)

HL5013 [245] ■
KA625 [13]
NF849 [15]

HBS120 ⊕
(22-51008B)
M12x1.50x118mm (x10)

JD409
(31-026628-10)

JN732
(50-026632-00)

JH5041
KG5012
16x23x1.5mm

HR569 ■
24-30667-00/0

NF846 25x42x7mm, FPM/ACM
(50-319516-00)
NA5036 ■ 42x54x6mm, FPM
(50-319473-00)
NF850 ■ 85x105x8mm, FPM
(50-319183-00)

HL5017 [245] ■

HBS372 ⊕
(22-51109B)
M12x1.50x121mm (x10)

JD5189

JM5086

JH5041
KG5012
16x23x1.5mm

HR646 ■
24-30670-60/0

NF846 25x42x7mm, FPM/ACM
(50-319516-00)
NA5036 ■ 42x54x6mm, FPM
(50-319473-00)
NF850 ■ 85x105x8mm, FPM
(50-319183-00)

HL5017 [245] ■

JD5895 ■
(Steel Elastomer)

HMS291 ■

JD5908 ■

NA5257 28x47x5.5mm

HBS116 ⊕
(22-51006B)
M12x1.50x243mm (x10)

JB954 ■

JN292
(50-024771-00)

JJ558
(Felt)
(Felt)
PB852
16x24x1.5mm
PA349
(33-102290-10)
22x16x2mm

HR569 ■
24-30667-00/0

NA5016 35x47x7mm, FPM/ACM
(50-305690-50)
NF843 ■ 50x68x10mm, FPM/ACM
(50-305667-70)
NF844 ■ 90x110x11mm, FPM/ACM











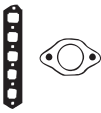

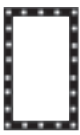

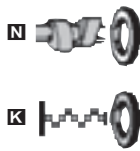





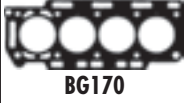











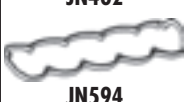































RENAULT



KW/PS

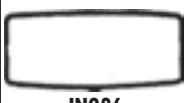

Trafic 2.0L 03/01 → 285					AD5990 (MLS) (30-029781-00)	CD5991	ED5991
F4R 720/F4R 722	1998	4	82.70	MPi	88/120		
Trafic 2.1L D Diesel 03/80 → 10/97 286					BH080 (Fibre), 1.60mm, 1 Hole (30-024772-10)	DH080▲ (21-24775-21/0)	EG176 [36] (22-24777-01/0)
Trafic 2.1L D 4x4 Diesel 11/86 → 04/89					BG900 (Fibre), 1.70mm (30-024773-10)		GH080▲ [36]
852 720/852 750	2068	4	86.00		43-44/ 58-60		
J8S 620/J8S 758	2068	4	86.00		47/64		
Trafic 2.2L 05/89 → 10/97 287					BH090 (Fibre), 1.80mm, 2 Holes (30-024774-10)	DG173 (21-27064-20/0)	EG176 [36] (22-24777-01/0)
Trafic 2.2L 4x4 05/89 → 10/97					BG170 (Fibre), 1.20mm (30-027064-10)		
J7T 780	2165	4	88.00	MPi	70/95		
J7T 600	2165	4	88.00	MPi	74/100		
Trafic 2.5L D Diesel 03/80 → 03/01 288					BE580 (Fibre), 1.35mm (30-024116-10)	DE588▲ [109] (21-26037-23/0)	FY291▲ [110] (20-27426-00/0)
8140.61.240/ S8U 720/S8U 722	2445	4	93.00		51/69		
Trafic 2.5L D Diesel 05/89 → 03/01 289					AY290 (Fibre), 1.60mm [112] (30-027426-00)	DE588▲ [109] (21-26037-23/0)	FY291▲ [12] (20-27426-00/0)
Trafic 2.5L D 4x4 Diesel 05/89 → 03/01					AY300 (Fibre), 1.70mm [112] (30-026654-20)		
8140.67.2500/ 8140.67.2550/ 8140.67.2580/ S8U 750/S8U 752/ S8U 758	2499	4	93.00		55/75		
Trafic 2.5L dCi 135 Diesel 03/01 → 290					AE5220 (MLS) (30-029037-00)		EE5220 (22-29037-00/0)
G9U 730	2464	4	89.00		99/135		
Twingo 1.2L 03/93 → 10/96 291					BV190 (Fibre), 1.25mm (30-027575-00)	DV190▲ (21-27577-20/0)	EV190 [36]
Twingo Van 1.2L 03/93 → 05/96					BX740 (Fibre), 1.75mm [34]	DX651 (21-27575-20/0)	
C3G 700/C3G 702	1239	4	74.00	SPi	40/54		
Twingo 1.2L 05/96 → 292					BX630 (Fibre) (30-028934-00)	DX630 (21-28934-20/0)	EA140 (22-28935-00/0)
Twingo Van 1.2L 05/96 →							
D7F 703/D7F 706	1149	4	69.00	MPi	43/58		
D7F 704	1149	4	69.00	MPi	43-44/ 58-60		
D7F 700/ D7F 701/D7F 702	1149	4	69.00	MPi	44/60		
Twingo 1.2L 16V 01/01 → 293					AD5980 (MLS) (30-029780-00)	CD5981	EG7950
D4F 702/D4F 704	1149	4	69.00	MPi	55/75		
Twingo 1.2L 16V 08/04 → 294					AD5980 (MLS) (30-029780-00)	CD5980 (21-29780-20/0)	EG7950
D4F 708	1149	4	69.00	Injection	44/60		

								
HBS310  (22-51108B) M12x1.50x117mm (x10)		HR397 [57] 34-000410-00	JH5041 ● KG5012 16x23x1.5mm	PA5013 (x16)	NA5257 28x47x5.5mm ■ NA5036 42x54x6mm, FPM (50-319473-00) ■ NF850 85x105x8mm, FPM (50-319183-00)	HL5039 [245] 		 AE5220  AY290, AY300, AY310  BE580  BG170  BG900  BH080, BH090  BV190, BX740  BX630  JB954  JC054  JC055  JD231  JD245  JD420  JD421  JN292  JN462  JN594  JN937  JN997  JJ100  JJ519  JJ558  JJ565
HBS010  (22-51104B) M12x1.50x247mm (x2) M12x1.50x148mm (x4) M12x1.50x134mm (x8)	JD245	JN697 (31-024775-10) Clamped injectors JN937 (31-028771-00) Screwed injectors	JJ558 (Felt) (Felt) ● PB852 16x24x1.5mm ● PA349 (33-102290-10) 22x16x2mm	HR569  24-30667-00/0	NA5016 35x47x7mm, FPM/ACM (50-305690-50) ■ NF843 50x68x10mm, FPM/ACM (50-305667-70) ■ NF844 90x110x11mm, FPM/ACM	HL5014 [245]  HR351 [37]  NF849 [15]		
HBS116  (22-51006B) M12x1.50x243mm (x10)	JB954 	JN292 (50-024771-00)	JJ558 (Felt) (Felt) ● PB852 16x24x1.5mm ● PA349 (33-102290-10) 22x16x2mm	HR569  24-30667-00/0	NA5016 35x47x7mm, FPM/ACM (50-305690-50) ■ NF843 50x68x10mm, FPM/ACM (50-305667-70) ■ NF844 90x110x11mm, FPM/ACM	HL5014 [245]  NF849 [15]		
HBS011  (22-51004B) M12x1.25x160mm (x10) M12x1.25x119mm (x12)	JC054  (31-024274-10) JC055  (31-025031-10)	JN462 (50-024272-00) →Eng.574478 JN594 [71] (50-026037-00) Eng.574479 →	JJ100 JJ519 (31-025623-00)	HR602  24-30670-61/0 HR782 	NP067 50x70x10mm, FPM (50-307111-70) ■ NP068 55x70x8mm, FPM (50-303186-00) ■ NP067 50x70x10mm, FPM (50-307111-70)	JR580 [11]		
HBS011  (22-51004B) M12x1.25x160mm (x10) M12x1.25x119mm (x12)	JC054  (31-024274-10) JC055  (31-025031-10)	JN462 (50-024272-00) →Eng.574478 JN594 [71] (50-026037-00) Eng.574479 →	JJ100 JJ519 (31-025623-00)	HR602  24-30670-61/0	NP067 50x70x10mm, FPM (50-307111-70) ■ NP068 55x70x8mm, FPM (50-303186-00) ■ NP067 50x70x10mm, FPM (50-307111-70) ■ NF885 [3] 70x159x16mm, FPM (50-307266-70) ■ NF883 [3] 114x171x13mm, FPM (50-307265-70)	HL5032 [245]  HJ271 [39]  JR580 [11] LC280 [11] LC281 [11] LC282 [11] KK5599 [45] KV927 [46]		
HBS373  (22-51110B) M12x1.50x131mm (x10)								
HBS104  (22-51005B) M10x1.50x100mm (x10)	JD231	JN936 (50-027577-00)	HC486  ● PA349 (33-102290-10) 22x16x2mm	HR643 	■ NF834 35x50x8mm, FPM (50-319241-00) ■ NF835 80x100x8mm, FPM/ACM (50-319239-00)	HT025 [37]  NF791 [38] LT839 [13] JR635 [11]		
HBS241  (22-51102B) M9x1.25x103mm (x10)	JD421  JD420 	JN997 →01/00 JM5131 (50-029881-00) 01/00 →	JJ565 ● PA349 (33-102290-10) 22x16x2mm	HR789 	■ NA5053 30x42x7mm, FPM (50-319488-00) ■ NF856 32x44x6mm, FPM/ACM	HL5021 [245]  NF791 [38]		
HBS283  (22-72004B) M9x1.25x122mm (x10)		JM5185			■ NA5261 28x47x8mm, PTFE	HL5036 [245] 		
HBS283  (22-72004B) M9x1.25x122mm (x10)	JD5885  JD5884 	JM5185 JM7053 (ACM)			■ NA5261 28x47x8mm, PTFE			 JN936









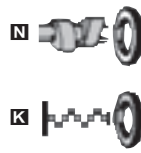
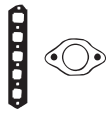









































KW/PS











Twingo 1.2L 16V				03/07 →	295		CD5140▲ (21-29278-00/0)	
D4F 772	1149	4	69.00	Injection				
Twingo 1.5L dCi Diesel				03/07 →	296	AG9490 (MLS) (30-029497-00)		EE5200
K9K 740	1461	4	76.00	Direct Injection				
Vel Satis 2.0L 16 V Turbo				04/04 →	297	AE5110 (MLS) (30-029811-00)	CE5110 (21-29811-20/0)	EE5110 (22-29811-00/0)
F4R 766/F4R 767	1998	4	82.70	Injection, DOHC				
Vel Satis 2.0L 16V Turbo				06/02 →	298	AE5110 (MLS) (30-029811-00)	CE5110 (21-29811-20/0)	EE5110 (22-29811-00/0)
F4R 762/F4R 763	1998	4	82.70		120/163			
Vel Satis 2.2L dCi Diesel				06/02 →	299	AE5210 (MLS), 1.24mm (30-029250-00)	CE5210	EE5220 (22-29037-00/0)
G9T 702	2188	4	87.00	Common Rail	95-110/ 130- 150			
Vel Satis 2.2L dCi Diesel				04/04 →	300	AE5210 (MLS), 1.24mm (30-029250-00)	CE5210	EE5220 (22-29037-00/0)
G9T 700	2188	4	87.00	Direct Injection, DOHC	110/150			
G9T 600	2188	4	87.00	Direct Injection, DOHC				
Vel Satis 3.0L dCi Diesel				06/02 →	301	AG9770 (MLS), 0.60mm, 1 Hole ☒ AG9780 (MLS), 0.65mm, 2 Holes ☒ AG9790 (MLS), 0.70mm, 3 Holes ☒ AG9800 (MLS), 0.60mm, 1 Hole ☒ AG9810 (MLS), 0.65mm, 2 Holes ☒ AG9820 (MLS), 0.70mm, 3 Holes ☒	CG9770▲	EG9770
P9X 701	2958	6	87.50		130/177			
Vel Satis 3.5L V6				06/02 →	302	AE5910 (MLS) ☒ AG6130 (MLS) ☒		EG8230
V4Y 701	3498	6	95.50		177/240			



AE5210

	JD5830   <i>(50-030266-00)</i> HA5031    <i>(24-35043-00/0)</i> HA5030    <i>(24-35042-90/0)</i> JD5829  <i>(31-030265-00)</i>	JM7034 <i>(50-030264-00)</i>			 NA5261 28x47x8mm, PTFE	
		JM7054 (NBR)			 NA5255  35x47x7mm	
HBS310  <i>(22-51108B)</i> M12x1.50x117mm (x10)	JD5911  JD5910 	HR397 [57] 34-000410-00	JH5041  KG5012 16x23x1.5mm	PA5013 (x16)	 NA5257 28x47x5.5mm  NA5036  42x54x6mm, FPM <i>(50-319473-00)</i>  NF850  85x105x8mm, FPM <i>(50-319183-00)</i>	
HBS310  <i>(22-51108B)</i> M12x1.50x117mm (x10)	JD5911  JD5910 	HR397 [57] 34-000410-00	JH5041  KG5012 16x23x1.5mm	PA5013 (x16)	 NA5257 28x47x5.5mm  NA5036  42x54x6mm, FPM <i>(50-319473-00)</i>  NF850  85x105x8mm, FPM <i>(50-319183-00)</i>	HL5039 [245] 
HBS373  <i>(22-51110B)</i> M12x1.50x131mm (x10)	JD5891  JD5892	HM5290 			 NA5053 (x2) 30x42x7mm, FPM <i>(50-319488-00)</i>  NF860  93x108x7mm, FPM	HL5035 [245] 
HBS373  <i>(22-51110B)</i> M12x1.50x131mm (x10)	JD5891  JD5892	HM5290 			 NA5053 30x42x7mm, FPM <i>(50-319488-00)</i>	
	JD5897  (Steel Elastomer) JD5896   JE5064 (Steel)	HM5292 		HR5094 		
		JM5317 				

		CC			9			CC			9
11 K2A	Petrol	1120	4	75.00	17	20 T4H	Petrol	1994	4	84.45	51
11 K2A	Petrol	1120	4	75.00	73	20 T4H	Petrol	1994	4	84.45	62
11 K2D	Petrol	1120	4	75.00	17	25 K4F	Petrol	2497	6	80.00	15
11 K2D	Petrol	1120	4	75.00	24	25 K4F	Petrol	2497	6	80.00	65
11 K2F	Petrol	1120	4	75.00	16	30 A	Petrol	3528	8	88.86	81
11 K2F	Petrol	1120	4	75.00	23	31 A	Petrol	3528	8	88.86	81
12 A2B	Petrol	1273	4		77	38 A	Petrol	3528	8	88.86	80
14 K2A	Petrol	1396	4	75.00	20	39 A	Petrol	3528	8	88.86	80
14 K2A	Petrol	1396	4	75.00	27	425 SL1RR	Diesel	2500	4	92.00	64
14 K2B	Petrol	1396	4	75.00	26	492 4 SHIRG	Diesel	2500	4	92.00	64
14 K2D	Petrol	1396	4	75.00	20	A Series (12 A2A)	Petrol	1275	4	70.61	76
14 K2D	Petrol	1396	4	75.00	27	A Series (12 A2L)	Petrol	1275	4	70.61	77
14 K2D	Petrol	1396	4	75.00	75	A+ Series	Petrol	1275	4	70.61	70
14 K2F	Petrol	1396	4	75.00	18	A+ Series (12 A2D)	Petrol	1275	4	70.61	77
14 K2F	Petrol	1396	4	75.00	29	A+ Series (12 A2E)	Petrol	1275	4	70.61	77
14 K2F	Petrol	1396	4	75.00	42	BB	Diesel	1996	4		78
14 K2F	Petrol	1396	4	75.00	74	C 25 A1	Petrol	2494	6		66
14 K4C	Petrol	1396	4	75.00	19	C 25 A2	Petrol	2494	6		66
14 K4C	Petrol	1396	4	75.00	28	C 27 A1	Petrol	2675	6	87.00	67
14 K4C	Petrol	1396	4	75.00	43	C 27 A2	Petrol	2675	6	87.00	67
14 K4C	Petrol	1396	4	75.00	75	D 16 A7	Petrol	1590	4	75.00	31
14 K4D	Petrol	1396	4	75.00	19	D 16 A7	Petrol	1590	4	75.00	46
14 K4D	Petrol	1396	4	75.00	28	D 16 A8	Petrol	1590	4	75.00	32
14 K4D	Petrol	1396	4	75.00	43	D 16 A8	Petrol	1590	4	75.00	45
14 K4F	Petrol	1396	4	75.00	1	D 16 A9	Petrol	1590	4	75.00	32
14 K4F	Petrol	1396	4	75.00	19	D 16 A9	Petrol	1590	4	75.00	45
14 K4F	Petrol	1396	4	75.00	28	D 16 Z2	Petrol	1590	4		31
14 K4F	Petrol	1396	4	75.00	43	D 16 Z2	Petrol	1590	4		46
14 K4F	Petrol	1396	4	75.00	6	EV 2	Petrol	1342	4	74.00	25
14 K4F	Petrol	1396	4	75.00	82	F 18 A3	Petrol	1849	4	85.00	54
14 K4M	Petrol	1396	4	75.00	1	F 20 Z1	Petrol	1997	4	85.00	55
14 K4M	Petrol	1396	4	75.00	82	F 20 Z2	Petrol	1997	4	85.00	55
16 H	Petrol	1598	4	76.50	30	H 23 A3	Petrol	2259	4	87.00	58
16 K4F	Petrol	1588	4	80.00	2	KV 6	Petrol	2497	6	80.00	15
16 K4F	Petrol	1588	4	80.00	33	M 47 R	Diesel	1950	4	84.00	13
16 K4F	Petrol	1588	4	80.00	44	M 8	Petrol	1994	4	84.45	59
16 K4F	Petrol	1588	4	80.00	68	Prima 65	Diesel	1994	4	84.45	71
16 K4F	Petrol	1588	4	80.00	7	Prima 80T	Diesel	1994	4	84.45	72
18 K4F	Petrol	1796	4	80.00	11	T 16	Petrol	1994	4	84.45	60
18 K4F	Petrol	1796	4	80.00	3	TUD 5	Diesel	1527	4	77.00	22
18 K4F	Petrol	1796	4	80.00	34	TUD3	Diesel	1361	4	75.00	21
18 K4F	Petrol	1796	4	80.00	8	VM 492 HT	Diesel	2393	4	92.00	79
18 K4K (VVC)	Petrol	1796	4	80.00	35	XUD 7TE	Diesel	1769	4	80.00	36
18 K4K (VVC)	Petrol	1796	4	80.00	4	XUD 7TE	Diesel	1769	4	80.00	48
18 K4K (VVC)	Petrol	1796	4	80.00	47	XUD9 A/B/L/Y	Diesel	1905	4	83.00	37
18 K4K (VVC)	Petrol	1796	4	80.00	69	XUD9 A/B/L/Y	Diesel	1905	4	83.00	49
20 HD	Petrol	1994	4	84.50	61						
20 HD M 16	Petrol	1994	4	84.50	61						
20 HS	Petrol	1994	4	84.50	63						
20 K4F	Petrol	1997	6	80.00	14						
20 K4F	Petrol	1997	6	80.00	9						
20 M4F	Petrol	1994	4	84.50	39						
20 M4F	Petrol	1994	4	84.50	50						
20 T2N (L Series)	Diesel	1994	4	84.45	10						
20 T2N (L Series)	Diesel	1994	4	84.45	41						
20 T2N (L Series)	Diesel	1994	4	84.45	5						
20 T2N (L Series)	Diesel	1994	4	84.45	53						
20 T2N (L Series)	Diesel	1994	4	84.45	56						
20 T2N (L Series)	Diesel	1994	4	84.45	83						
20 T2R (L Series)	Diesel	1994	4	84.45	10						
20 T2R (L Series)	Diesel	1994	4	84.45	41						
20 T2R (L Series)	Diesel	1994	4	84.45	5						
20 T2R (L Series)	Diesel	1994	4	84.45	53						
20 T4G	Petrol	1994	4	84.45	40						
20 T4G	Petrol	1994	4	84.45	52						
20 T4G	Petrol	1994	4	84.45	57						
20 T4G	Petrol	1994	4	84.45	60						
20 T4H	Petrol	1994	4	84.45	38						
20 T4H	Petrol	1994	4	84.45	50						



KW/PS









25 1.4L 16V					10/99 →	1			
14 K4M	1396	4	75.00			62/84	BW5750 (MLS) [246] (30-030305-00)	DW5757 [247] (21-30305-00/0)	ER320 [26] (22-29293-00/0)
14 K4F	1396	4	75.00	MPi, DOHC		76/103	BW750 (Steel Elastomer) (30-029292-00)	DW5759 ☒ ○ [246] [247]	ER321 [201] (22-29294-00/0)
							KM5001 [190] (40-029292-00)	DW757 (21-29292-24/0)	DW759 ☒ ○
25 1.6L 16V					10/99 →	2			
16 K4F	1588	4	80.00	MPi, DOHC		110/110	BW5750 (MLS) [246] (30-030305-00)	DW5757 [247] (21-30305-00/0)	ER322 (22-29294-01/0)
							BW750 (Steel Elastomer) (30-029292-00)	DW5759 ☒ ○ [246] [247]	
							KM5001 [190] (40-029292-00)	DW757 (21-29292-24/0)	DW759 ☒ ○
25 1.8L 16V					10/99 →	3			
18 K4F	1796	4	80.00	Injection, DOHC		87/118	BW5750 (MLS) [246] (30-030305-00)	DW5757 [247] (21-30305-00/0)	ER322 (22-29294-01/0)
							BW750 (Steel Elastomer) (30-029292-00)	DW5759 ☒ ○ [246] [247]	
							KM5001 [190] (40-029292-00)	DW757 (21-29292-24/0)	DW759 ☒ ○
25 1.8L 16V					02/00 →	4			
18 K4K (VVC)	1796	4	80.00	MPi, DOHC		86/ 146- 160	BW5750 (MLS) [246] (30-030305-00)	DW754 (21-29292-21/0)	ER322 (22-29294-01/0)
							BW750 (Steel Elastomer) (30-029292-00)		
							KM5001 [190] (40-029292-00)		
25 2.0L Diesel					04/00 → 01/05	5			
20 T2R (L Series)	1994	4	84.45	Direct Injection, SOHC, Turbo		63/86	BZ440 (MLS), 1.05mm, 1 Hole (30-029569-00)	DZ440 ▲ (21-29569-20/0)	EZ440 [12] (22-29569-00/0)
20 T2N (L Series)	1994	4	84.45	EFi, SOHC		74-83/ 101- 113	BZ450 (MLS), 1.20mm, 2 Holes (30-029570-00)		→ Ch.YD471564
							BZ460 (MLS), 1.35mm, 3 Holes (30-029571-00)		EZ441 [12] (22-29569-01/0)
									Ch.YD471565 →
45 1.4L					02/00 →	6			
14 K4F	1396	4	75.00	MPi, DOHC		76/103	BW5750 (MLS) [246] (30-030305-00)	DW5757 [247] (21-30305-00/0)	ER320 [26] (22-29293-00/0)
							BW750 (Steel Elastomer) (30-029292-00)	DW5759 ☒ ○ [246] [247]	ER321 [201] (22-29294-00/0)
							KM5001 [190] (40-029292-00)	DW757 (21-29292-24/0)	DW759 ☒ ○

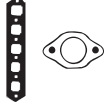

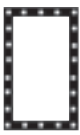
KW/PS

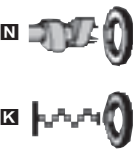







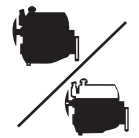



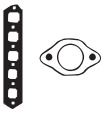

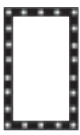













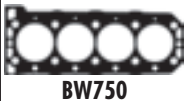













































	 						
HBS005 ® (22-89005B) M9x1.25x412mm (x10)	JD311 [192] (50-029305-00) (FPM) JC852 ® (31-029304-00)	JN963 (31-029297-00)		HR752 ® (24-31939-80/0)	NC065 ® (x2) 30x40x7mm, FPM (50-306142-00) Black NB998 ® (x2) 30x40x7mm, FPM (50-319402-00) Brown NB828 ® 27.5x39.5x7mm, FPM (50-319399-00) NB829 ® 79.95x116x11.5mm, FPM (50-319400-00)		
HBS005 ® (22-89005B) M9x1.25x412mm (x10)	JD311 [192] (50-029305-00) (FPM) JC852 ® (31-029304-00)	JN963 (31-029297-00)		HR752 ® (24-31939-80/0)	NC065 ® (x2) 30x40x7mm, FPM (50-306142-00) Black NB998 ® (x2) 30x40x7mm, FPM (50-319402-00) Brown NB828 ® 27.5x39.5x7mm, FPM (50-319399-00) NB829 ® 79.95x116x11.5mm, FPM (50-319400-00)		
HBS423 (22-89009B) M9x1.25x200mm (x16)	JA5079 [192] (x2) (31-029413-00) JA5078 [192] (x2) (31-029412-00)	JM5035 (x2) (31-029414-00)		HR5031 [192] (x2) (24-31939-81/0)	NC065 ® (x2) 30x40x7mm, FPM (50-306142-00) Black NB998 ® (x4) 30x40x7mm, FPM (50-319402-00) Brown NA5083 ® 32.5x45x7.7mm, FPM (50-319423-00) LK5000 [3] 89x116x10.2mm, FPM (50-319424-00)		
HBS282 ® (22-72002B) M11x1.50x230mm (x10)	JD657	JP097	JH5012	HR5051 ®	NB775 ® (x2) 40x52x7mm, FPM NB774 ® 35x45x7mm, FPM (50-319419-00) NB843 [3] 128x145x28mm, FPM (50-319420-00) →Ch.YD471063 LK5002 [3] 136x153x21mm, PTFE (50-319427-00) Ch.YD471064→		
HBS005 ® (22-89005B) M9x1.25x412mm (x10)	JD311 [192] (50-029305-00) (FPM) JC852 ® (31-029304-00)	JN963 (31-029297-00)		HR752 ® (24-31939-80/0)	NC065 ® (x2) 30x40x7mm, FPM (50-306142-00) Black NB998 ® (x2) 30x40x7mm, FPM (50-319402-00) Brown NB828 ® 27.5x39.5x7mm, FPM (50-319399-00) NB829 ® 79.95x116x11.5mm, FPM (50-319400-00)		
HBS005 ® (22-89005B) M9x1.25x412mm (x10)	JD311 [192] (50-029305-00) (FPM)	JN963 (31-029297-00)		HR752 ® (24-31939-80/0)	NC065 ® (x2) 30x40x7mm, FPM (50-306142-00) NB998 ® (x2) 30x40x7mm, FPM (50-319402-00) NB828 ® 27.5x39.5x7mm, FPM (50-319399-00) NB829 ® 79.95x116x11.5mm, FPM (50-319400-00)		



KWPS



75 2.0L CDT Diesel				02/99 →		13	BZ690 (MLS), 1.45mm, 1 Hole (30-028564-00) BZ700 (MLS), 1.55mm, 2 Holes (30-028565-00) BZ710 (MLS), 1.65mm, 3 Holes (30-028566-00)		DZ690▲■ (21-29456-20/0)	EZ690 (22-29457-00/0)
M 47 R	1950	4	84.00			85/116				
75 2.0L V6				02/99 →		14	AA5920 (MLS) (x2) (30-028596-20)		CA5920 (21-28596-20/0)	EA5920 [12] (22-28596-00/0)
20 K4F	1997	6	80.00	DOHC, V6		110/150				
75 2.5L V6				02/99 →10/01		15	AA5920 (MLS) (x2) (30-028596-20)		CA5920 (21-28596-20/0)	EA5920 [12] (22-28596-00/0)
KV 6	2497	6	80.00	Injection, DOHC, V6		129/175				
25 K4F	2497	6	80.00	V6		130/177				
100 111				01/95 →		16	BW5750 (MLS) [246] (30-030305-00) BW750 (Steel Elastomer) (30-029292-00) KM5001 [190] (40-029292-00)		DW756 (21-29292-23/0)	ER320 [26] (22-29293-00/0) ER321 [201] (22-29294-00/0)
11 K2F	1120	4	75.00	MPi, SOHC		44/60				
100 111 C/L/S				03/90 →12/98		17	BW5750 (MLS) [246] (30-030305-00) BW750 (Steel Elastomer) (30-029292-00) KM5001 [190] (40-029292-00)		DW750 [218] (21-29292-20/0) DW755 [219] (21-29292-22/0)	ER320 [26] (22-29293-00/0) ER321 [201] (22-29294-00/0)
100 Convertible 111				04/94 →						
11 K2A	1120	4	75.00	Carburettor, SOHC		44/60				
11 K2D	1120	4	75.00	SPi, SOHC		44/60				
100 114				01/95 →07/98		18	BW5750 (MLS) [246] (30-030305-00) BW750 (Steel Elastomer) (30-029292-00) KM5001 [190] (40-029292-00)		DW756 (21-29292-23/0)	ER320 [26] (22-29293-00/0) ER321 [201] (22-29294-00/0)
14 K2F	1396	4	75.00	MPi, SOHC		55/75				











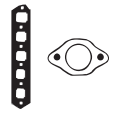

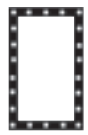

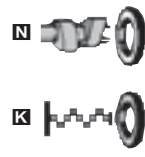













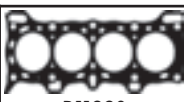



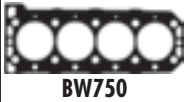

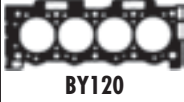

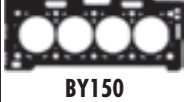

























































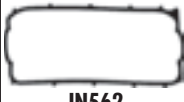















								
HBS121  [22-11006B] M12x1.50x146.5mm (x10)	HA5006  [24-29152-00/0] JD5183  (x2) [31-029124-00]	JM5076 [50-029456-00]	JH5032  [31-029457-00] JH5033  [31-029458-00]	PA5016 (x16) 50-307240-70 HR5045  24-30724-07/0	NA5103  55x68x8mm, PTFE [50-319391-00] NA5104  90x110x12mm, PTFE [50-319389-00]			 AA5920  JH5033  BW5750  BW750  BZ690, BZ700, BZ710  JA5078  JA5079  JD5183  JD654  JD655  JD656  LA564  JM5035  JM5076  JN736  JP065  JH5016  JH5032
HBS423 [22-89009B] M9x1.25x200mm (x16)	JA5079  (x2) [31-029413-00] JA5078  (x2) [31-029412-00]	JM5035 (x2) [31-029414-00]		HR5031  (x2) [24-31939-81/0]	NC065  (x2) 30x40x7mm, FPM [50-306142-00] Black NB998  (x4) 30x40x7mm, FPM [50-319402-00] Brown NA5083  32.5x45x7.7mm, FPM [50-319423-00] LK5000  [3] 89x116x10.2mm, FPM [50-319424-00]			
HBS423 [22-89009B] M9x1.25x200mm (x16)	JA5079  (x2) [31-029413-00] JA5078  (x2) [31-029412-00]	JM5035 (x2) [31-029414-00]		HR5031  (x2) [24-31939-81/0]	NC065  (x2) 30x40x7mm, FPM [50-306142-00] Black NB998  (x4) 30x40x7mm, FPM [50-319402-00] Brown NA5083  32.5x45x7.7mm, FPM [50-319423-00] LK5000  [3] 89x116x10.2mm, FPM [50-319424-00]			
HBS005  [22-89005B] M9x1.25x412mm (x10)	JD655  [31-029301-00] JD656  [31-029298-00] JD654  [31-029299-00]	JP065 [31-029296-00] (Rubber/Metal)	JH5016 [201] [50-029294-00] JJ404 [26] [50-029293-00]	HR656  [24-31939-70/0]	NC065  30x40x7mm, FPM [50-306142-00] Black NB998  30x40x7mm, FPM [50-319402-00] Brown NB828  27.5x39.5x7mm, FPM [50-319399-00] NB829  79.95x116x11.5mm, FPM [50-319400-00]			
HBS005  [22-89005B] M9x1.25x412mm (x10)	LA564  JD656  [31-029298-00] JD654  [31-029299-00]	JN736 [50-029295-00] (Rubber) JP065 [31-029296-00] (Rubber/Metal)	JH5016 [201] [50-029294-00] JJ404 [26] [50-029293-00]	HR656  [24-31939-70/0]	NC065  30x40x7mm, FPM [50-306142-00] Black NB998  30x40x7mm, FPM [50-319402-00] Brown NB828  27.5x39.5x7mm, FPM [50-319399-00] NB829  79.95x116x11.5mm, FPM [50-319400-00]			
HBS005  [22-89005B] M9x1.25x412mm (x10)	JD655  [31-029301-00] JD656  [31-029298-00] JD654  [31-029299-00]	JP065 [31-029296-00] (Rubber/Metal)	JH5016 [201] [50-029294-00] JJ404 [26] [50-029293-00]	HR656  [24-31939-70/0]	NC065  30x40x7mm, FPM [50-306142-00] Black NB998  30x40x7mm, FPM [50-319402-00] Brown NB828  27.5x39.5x7mm, FPM [50-319399-00] NB829  79.95x116x11.5mm, FPM [50-319400-00]			



KWPS



100 114 GSi 10/94 → 10/95 19						BW5750 (MLS) [246] (30-030305-00) BW750 (Steel Elastomer) (30-029292-00) KM5001 [190] (40-029292-00)	DW5757 [247] (21-30305-00/0) DW5759 ☒ ○ [246] [247] DW757 (21-29292-24/0) DW759 ☒ ○	ER320 [26] (22-29293-00/0) ER321 [201] (22-29294-00/0)
100 114 GTI 16V 03/90 → 12/98								
100 114 GTI/GT 16V 03/90 → 12/98								
100 Convertible 114 03/97 → 10/98								
14 K4C	1396	4	75.00	SPi, DOHC	66-70/ 90-95			
14 K4D	1396	4	75.00	SPi, DOHC	75/77			
14 K4F	1396	4	75.00	MPi, DOHC	76/103			
100 114 S/L/GTA 03/90 → 12/98 20						BW5750 (MLS) [246] (30-030305-00) BW750 (Steel Elastomer) (30-029292-00) KM5001 [190] (40-029292-00)	DW750 [218] (21-29292-20/0) DW755 [219] (21-29292-22/0)	ER320 [26] (22-29293-00/0) ER321 [201] (22-29294-00/0)
100 Convertible 114 04/94 →								
14 K2A	1396	4	75.00	Carburettor, SOHC	55/75			
14 K2D	1396	4	75.00	SPi, SOHC	55/75			
100 114 D Diesel 10/92 → 12/94 21						BY120 (Fibre), 1.80mm (30-029802-00)	DS731 ▲ (21-26844-21/0)	
TUD3	1361	4	75.00	SOHC	38/52			
100 115 D Diesel 12/94 → 12/98 22						BY150 (Fibre), 1.75mm (30-028755-00)	DY150 ▲ (21-28757-20/0)	
TUD 5	1527	4	77.00	SOHC	42/57			
200 211 01/98 → 03/00 23						BW5750 (MLS) [246] (30-030305-00) BW750 (Steel Elastomer) (30-029292-00) KM5001 [190] (40-029292-00)	DW756 (21-29292-23/0)	ER320 [26] (22-29293-00/0) ER321 [201] (22-29294-00/0)
11 K2F	1120	4	75.00	MPi, SOHC	44/60			
200 211 01/98 → 03/00 24						BW5750 (MLS) [246] (30-030305-00) BW750 (Steel Elastomer) (30-029292-00) KM5001 [190] (40-029292-00)	DW750 [218] (21-29292-20/0) DW755 [219] (21-29292-22/0)	ER320 [26] (22-29293-00/0) ER321 [201] (22-29294-00/0)
11 K2D	1120	4	75.00	SPi, SOHC	44/60			
200 213 S 09/85 → 09/89 25						BM990 (Graphite) (30-026714-10)	DM995 (21-26714-22/0)	EM992 GM990
EV 2	1342	4	74.00	SOHC	54/73			

								
HBS005  (22-89005B) M9x1.25x412mm (x10)	JD311  [192] (50-029305-00) (FPM) JC907   [217] (31-029302-00) JC877   [217] (31-029303-00) JC852  (31-029304-00)	JN963 (31-029297-00)	JH5016 [201] (50-029294-00) JJ404 [26] (50-029293-00)	HR752  (24-31939-80/0)	NC065  (x2) 30x40x7mm, FPM (50-306142-00) Black NB998  (x2) 30x40x7mm, FPM (50-319402-00) Brown NB828  27.5x39.5x7mm, FPM (50-319399-00) NB829  79.95x116x11.5mm, FPM (50-319400-00)			 BM990  JH5016  BW5750  JJ309  BW750  JJ404  BY120  JJ587  BY150  JC852  JC877  JC907  JD311  JD654  JD655  JD656  LA564  JN562  JN736  JN758  JN963  JP065
HBS005  (22-89005B) M9x1.25x412mm (x10)	LA564   (31-029298-00) JD656    (31-029298-00) JD654  (31-029299-00)	JN736 (50-029295-00) (Rubber) JP065 (31-029296-00) (Rubber/Metal)	JH5016 [201] (50-029294-00) JJ404 [26] (50-029293-00)	HR656  (24-31939-70/0)	NC065  30x40x7mm, FPM (50-306142-00) Black NB998  30x40x7mm, FPM (50-319402-00) Brown NB828  27.5x39.5x7mm, FPM (50-319399-00) NB829  79.95x116x11.5mm, FPM (50-319400-00)			 HL5011 [245]   HR564 [37]  
HBS082  (22-15001B) M10x1.50x185mm (x10)		JN758		HR642 	NF817  36x50x7mm, FPM (50-319112-00) NF870  42x66x6mm, FPM/ACM (50-319113-00) NF857  85x105x9mm, FPM/ACM (50-319478-00)		HL5011 [245]   HR564 [37]  	
HBS113  (22-150015B) M11x1.50x185mm (x10)			JJ587 PB907 14x21x2mm	HR642 	NF817  36x50x7mm, FPM (50-319112-00) NF870  42x66x6mm, FPM/ACM (50-319113-00) NF857  85x105x9mm, FPM/ACM (50-319478-00)		HL5011 [245]  	
HBS005  (22-89005B) M9x1.25x412mm (x10)	JD655   (31-029301-00) JD656    (31-029298-00) JD654  (31-029299-00)	JP065 (31-029296-00) (Rubber/Metal)	JH5016 [201] (50-029294-00) JJ404 [26] (50-029293-00)	HR656  (24-31939-70/0)	NC065  30x40x7mm, FPM (50-306142-00) Black NB998  30x40x7mm, FPM (50-319402-00) Brown NB828  27.5x39.5x7mm, FPM (50-319399-00) NB829  79.95x116x11.5mm, FPM (50-319400-00)			 JN562  JN736  JN758  JN963  JP065
HBS005  (22-89005B) M9x1.25x412mm (x10)	LA564   (31-029298-00) JD656    (31-029298-00) JD654  (31-029299-00)	JN736 (50-029295-00) (Rubber) JP065 (31-029296-00) (Rubber/Metal)	JH5016 [201] (50-029294-00) JJ404 [26] (50-029293-00)	HR656  (24-31939-70/0)	NC065  30x40x7mm, FPM (50-306142-00) Black NB998  30x40x7mm, FPM (50-319402-00) Brown NB828  27.5x39.5x7mm, FPM (50-319399-00) NB829  79.95x116x11.5mm, FPM (50-319400-00)			 JN562  JN736  JN758  JN963  JP065
		JN562 (50-026763-00)	JJ309	PA531  (x4) PA528  (x8)	NJ313  29x45x8mm, ACM NJ381  31x46x8mm, NBR NJ312  80x100x10mm, MVQ			



KWPS



200 214 (cat)				08/90 → 04/92		26	BW5750 (MLS) [246] (30-030305-00) BW750 (Steel Elastomer) (30-029292-00) KM5001 [190] (40-029292-00)		DW750 (21-29292-20/0)	ER320 [26] (22-29293-00/0)
14 K2B	1396	4	75.00	Carburettor, DOHC		55/75				
200 214				09/93 → 10/95		27	BW5750 (MLS) [246] (30-030305-00) BW750 (Steel Elastomer) (30-029292-00) KM5001 [190] (40-029292-00)		DW750 [218] (21-29292-20/0) DW755 [219] (21-29292-22/0)	ER320 [26] (22-29293-00/0) ER321 [201] (22-29294-00/0)
14 K2A	1396	4	75.00	Carburettor, SOHC		55/75				
14 K2D	1396	4	75.00	SPi, SOHC		55/75				
200 214 GSi/Si				01/90 → 10/95		28	BW5750 (MLS) [246] (30-030305-00) BW750 (Steel Elastomer) (30-029292-00) KM5001 [190] (40-029292-00)		DW5757 [247] (21-30305-00/0) DW5759 ☒ ○ [246] [247] DW757 (21-29292-24/0) DW759 ☒ ○	ER320 [26] (22-29293-00/0) ER321 [201] (22-29294-00/0)
200 214 Si				11/95 → 03/00						
200 214 Si/GSi				10/89 → 10/95						
14 K4C	1396	4	75.00	SPi, DOHC		66-70/ 90-95				
14 K4D	1396	4	75.00	SPi, DOHC		75/77				
14 K4F	1396	4	75.00	MPi, DOHC		76/103				
200 214 i				11/95 → 03/00		29	BW5750 (MLS) [246] (30-030305-00) BW750 (Steel Elastomer) (30-029292-00) KM5001 [190] (40-029292-00)		DW756 (21-29292-23/0)	ER320 [26] (22-29293-00/0) ER321 [201] (22-29294-00/0)
14 K2F	1396	4	75.00	MPi, SOHC		55/75				
200 216				03/85 → 09/89		30	BL380 (Fibre)		DL381 01/86 → 12/88 DL382 01/89 → 09/90	
200 216 Vitesse				03/85 → 09/89						
16 H	1598	4	76.50	Carburettor, SOHC		61-75/ 83-102				
200 216 GSi				10/89 → 10/95		31	BV350 (Graphite) (30-028143-00)		DV351 (21-28143-21/0) 01/92 →	
D 16 Z2	1590	4		Injection, SOHC		82/111				
D 16 A7	1590	4	75.00			85/116				
200 216 GTi				09/90 → 10/95		32	BS880 (Graphite) (30-028150-00)		DS881 (21-28150-20/0)	GS881
200 Coupe 216				10/92 → 06/99						
D 16 A8	1590	4	75.00	Injection, DOHC		90/122				
D 16 A9	1590	4	75.00			96/131				
200 216 Si				11/95 → 03/00		33	BW5750 (MLS) [246] (30-030305-00) BW750 (Steel Elastomer) (30-029292-00) KM5001 [190] (40-029292-00)		DW5757 [247] (21-30305-00/0) DW5759 ☒ ○ [246] [247] DW757 (21-29292-24/0) DW759 ☒ ○	ER322 (22-29294-01/0)
200 Convertible 216 1.6Li 16V				01/96 → 11/99						
16 K4F	1588	4	80.00	MPi, DOHC		110/110				

HBS005 ® [22-89005B] M9x1.25x412mm (x10)	LA564 JD656 JD654	JN736 (50-029295-00) (Rubber)	JJ404 [26] (50-029293-00)	HR656 (24-31939-70/0)	N K NC065 30x40x7mm, FPM (50-306142-00) NB828 27.5x39.5x7mm, FPM (50-319399-00) NB829 79.95x116x11.5mm, FPM (50-319400-00)		
HBS005 ® [22-89005B] M9x1.25x412mm (x10)	LA564 JD656 JD654	JN736 (50-029295-00) (Rubber) JP065 (31-029296-00) (Rubber/Metal)	JH5016 [201] (50-029294-00) JJ404 [26] (50-029293-00)	HR656 (24-31939-70/0)	N NC065 30x40x7mm, FPM (50-306142-00) Black NB998 30x40x7mm, FPM (50-319402-00) Brown NB828 27.5x39.5x7mm, FPM (50-319399-00) NB829 79.95x116x11.5mm, FPM (50-319400-00)		
HBS005 ® [22-89005B] M9x1.25x412mm (x10)	JD311 [192] (50-029305-00) (FPM) JC907 [217] (31-029302-00) JC877 [217] (31-029303-00) JC852 (31-029304-00)	JN963 (31-029297-00)	JH5016 [201] (50-029294-00) JJ404 [26] (50-029293-00)	HR752 (24-31939-80/0)	N NC065 (x2) 30x40x7mm, FPM (50-306142-00) Black NB998 (x2) 30x40x7mm, FPM (50-319402-00) Brown NB828 27.5x39.5x7mm, FPM (50-319399-00) NB829 79.95x116x11.5mm, FPM (50-319400-00)		
HBS005 ® [22-89005B] M9x1.25x412mm (x10)	JD655 (31-029301-00) JD656 (31-029298-00) JD654 (31-029299-00)	JP065 (31-029296-00) (Rubber/Metal)	JH5016 [201] (50-029294-00) JJ404 [26] (50-029293-00)	HR656 (24-31939-70/0)	N NC065 30x40x7mm, FPM (50-306142-00) Black NB998 30x40x7mm, FPM (50-319402-00) Brown NB828 27.5x39.5x7mm, FPM (50-319399-00) NB829 79.95x116x11.5mm, FPM (50-319400-00)		
	JC240	JN549 03/85 → 12/85		HR622 (x2)	N NB775 (x2) 40x52x7mm, FPM NB586 30x40x7mm, MVQ NB772 88.9x104.8x9.52mm, MVQ		
	JD075 JD052 JF024 (x2) JE625	JN744		PB355 (x8) PB356 (x8)	N NJ313 29x45x8mm, ACM NK159		
	JC674	JN925	JJ309	PB156 (x8)	N NJ381 31x46x8mm, NBR NJ312 80x100x10mm, MVQ		
HBS005 ® [22-89005B] M9x1.25x412mm (x10)	JD311 [192] (50-029305-00) (FPM) JC852 (31-029304-00)	JN963 (31-029297-00)		HR752 (24-31939-80/0)	N NC065 (x2) 30x40x7mm, FPM (50-306142-00) Black NB998 (x2) 30x40x7mm, FPM (50-319402-00) Brown NB828 27.5x39.5x7mm, FPM (50-319399-00) NB829 79.95x116x11.5mm, FPM (50-319400-00)		



KWPS



200 218i		06/97 → 10/99			34	BW5750 (MLS) [246] (30-030305-00) BW750 (Steel Elastomer) (30-029292-00) KM5001 [190] (40-029292-00)	DW5757 [247] (21-30305-00/0) DW5759 ☒ ○ [246] [247] DW757 (21-29292-24/0) DW759 ☒ ○	ER322 (22-29294-01/0)
18 K4F	1796	4	80.00	Rover K Series, Injection, DOHC	87/118			
200 218 K Vi		11/95 → 03/00			35	BW5750 (MLS) [246] (30-030305-00) BW750 (Steel Elastomer) (30-029292-00) KM5001 [190] (40-029292-00)	DW754 (21-29292-21/0)	ER322 (22-29294-01/0)
18 K4K (VVC)	1796	4	80.00	MPi, DOHC	86/ 146- 160			
200 218 TD Diesel		09/91 → 10/95			36	BR780 (Fibre), 1.65mm, 2 Notches ☒-0.65 → 0.77mm BR790 (Fibre), 1.80mm, 3 Notches (30-026855-10) ☒-0.77 → 0.82mm	DJ720 ▲ (21-25202-22/0)	EL890 (22-25198-01/0) GJ720 ▲ (20-25202-02/0)
XUD 7TE	1769	4	80.00		44/66/ 60/90			
200 218 D Diesel		09/91 → 10/95			37	BX880 (Fibre), 1.36mm, 1 Notch (30-028475-00) ☒-0.56 → 0.67mm BX890 (Fibre), 1.40mm, 2 Notches (30-028476-00) ☒-0.68 → 0.71mm BX900 (Fibre), 1.44mm, 3 Notches (30-028477-00) ☒-0.72 → 0.75mm BX910 (Fibre), 1.48mm, 4 Notches (30-028478-00) ☒-0.76 → 0.79mm BX920 (Fibre), 1.52mm, 5 Notches (30-028479-00) ☒-0.80 → 0.83mm	DJ720 ▲ (21-25202-22/0)	EL890 (22-25198-01/0) GJ720 ▲ (20-25202-02/0)
XUD9 A/B/L/Y	1905	4	83.00		52/71			
200 220 GTi		01/93 → 10/95			38	BS790 (Fibre) → 12/94 AB5400 (MLS) (30-029270-00) 01/95 →	DS792 [221] [222] → 12/94 DS795 [222] [223] → 12/94 DS797 [221] [224] 01/94 → 12/94 CB5400 (21-29270-20/0) 01/95 →	ES790 → 12/94 EB5400 [12] (22-29271-00/0) 01/95 →
20 T4H	1994	4	84.45	injection				
200 Coupe 220 GSi		05/94 → 06/99						
200 220 GTi		09/91 → 10/95			39	BS790 (Fibre)	DS793	EM682
20 M4F	1994	4	84.50	Injection, DOHC	103/140			

HBS005 Ⓢ (22-89005B) M9x1.25x412mm (x10)	JD311 [192] (50-029305-00) (FPM) JC852 (31-029304-00)	JN963 (31-029297-00)		HR752 (24-31939-80/0)	▣ NC065 (x2) 30x40x7mm, FPM (50-306142-00) Black ▣ NB998 (x2) 30x40x7mm, FPM (50-319402-00) Brown ▣ NB828 27.5x39.5x7mm, FPM (50-319399-00) ▣ NB829 79.95x116x11.5mm, FPM (50-319400-00)							AB5400 BR780, BR790 BS790 BW5750 BW750 BX880, BX890, BX900, BX910, BX920 JC852 JC908 JC909 JC949 JC950 JC991 JD311 JD563 JD564 JM5045 JN544 JN836 JN963 LB161 LB162	LB536 JH5022 JJ283 JJ315 JJ446
HBS005 Ⓢ (22-89005B) M9x1.25x412mm (x10)	JD564 [220] (31-029307-00) JD563 [220] (31-029306-00) JC852 (31-029304-00)	JN963 (31-029297-00)		HR752 (24-31939-80/0)	▣ NC065 (x2) 30x40x7mm, FPM (50-306142-00) Black ▣ NB998 (x2) 30x40x7mm, FPM (50-319402-00) Brown ▣ NB828 27.5x39.5x7mm, FPM (50-319399-00) ▣ NB829 79.95x116x11.5mm, FPM (50-319400-00)							JC908 JC909 JC949 JC950 JC991 JD311 JD563 JD564 JM5045 JN544 JN836 JN963 LB161 LB162	JJ283 JJ315 JJ446
HBS084 Ⓢ (22-15005B) M12x1.50x123mm (x10)	JC991 (31-028595-00)	JN544 (50-025202-00)	JJ283 [6] (31-025198-10) ● PA349 (33-102290-10) 22x16x2mm	HR569 24-30667-00/0	▣ NF746 36x50x7mm, ACM (50-306399-00) ▣ NA5191 42x62x7mm, PTFE (50-319500-00) ▣ NA5192 90x110x7mm, PTFE (50-319501-00)							JC908 JC909 JC949 JC950 JC991 JD311 JD563 JD564 JM5045 JN544 JN836 JN963 LB161 LB162	
HBS084 Ⓢ (22-15005B) M12x1.50x123mm (x10)		JN544 (50-025202-00)	JJ283 [6] (31-025198-10) ● PA349 (33-102290-10) 22x16x2mm	HR569 24-30667-00/0	▣ NF841 (x2) 35x50x8mm, FPM (50-319310-00) ▣ NA5191 42x62x7mm, PTFE (50-319500-00) ▣ NA5192 90x110x7mm, PTFE (50-319501-00)				HL5010 [245] Ⓢ			JC908 JC909 JC949 JC950 JC991 JD311 JD563 JD564 JM5045 JN544 JN836 JN963 LB161 LB162	
HBS305 Ⓢ (22-89007B) M11x1.50x162mm (x10)	JC950 [220] (31-029333-00) JC949 [220] JC909 (31-029335-00)	LB162 (Rubber/Metal) →12/94 LB161 (Rubber/Metal) →12/94 JM5045 (50-029331-00) (Rubber) 01/95→ LB536 (Rubber)	JJ446 →12/94 JH5022 (50-029271-00) 01/95→	HR802 Green →12/94 HR656 (x2) (24-31939-70/0) Black 01/94→	▣ NB775 (x4) 40x52x7mm, FPM 01/95→12/94 ▣ NB774 35x45x7mm, FPM (50-319419-00) ▣ NB843 [3] 128x145x28mm, FPM (50-319420-00)							JC908 JC909 JC949 JC950 JC991 JD311 JD563 JD564 JM5045 JN544 JN836 JN963 LB161 LB162	
HBS305 Ⓢ (22-89007B) M11x1.50x162mm (x10)	JC908 [220] JC909 (31-029335-00)	JN836	JJ315	HR802	▣ NB775 (x4) 40x52x7mm, FPM (50-319419-00) ▣ NB774 35x45x7mm, FPM (50-319419-00) ▣ NB772 88.9x104.8x9.52mm, MVQ							JC908 JC909 JC949 JC950 JC991 JD311 JD563 JD564 JM5045 JN544 JN836 JN963 LB161 LB162	











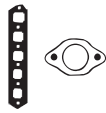

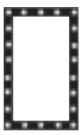

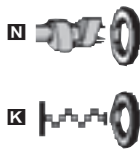









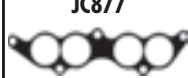







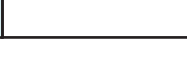











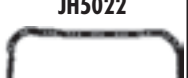







ROVER

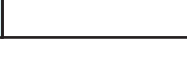

KW/PS

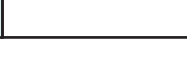

200 220 Turbo 01/93 → 10/95 40					BS860 (Fibre) →12/94 AB5400 (MLS) (30-029270-00) 01/95 →	DS860 [222] [223] →12/94 DS862 [221] [222] →12/94 CB5400 (21-29270-20/0) 01/95 →	ES790 →12/94 EB5400 [12] (22-29271-00/0) 01/95 →
200 Coupe 220 Turbo 10/92 → 06/99							
20 T4G	1994	4	84.45		100/136		
200 220 D/SD Diesel 11/95 → 03/00 41					BZ440 (MLS), 1.05mm, 1 Hole (30-029569-00) BZ450 (MLS), 1.20mm, 2 Holes (30-029570-00) BZ460 (MLS), 1.35mm, 3 Holes (30-029571-00)	DZ440 ▲ (21-29569-20/0)	EZ440 [12] (22-29569-00/0) →Ch.YD471564 EZ441 [12] (22-29569-01/0) Ch.YD471565 →
200 220 SDi Diesel 11/95 → 03/00							
20 T2R (L Series)	1994	4	84.45	Direct Injection, SOHC			
20 T2N (L Series)	1994	4	84.45	Efi, SOHC	74-83/ 101- 113		
400 1.4L 03/97 → 10/99 42					BW5750 (MLS) [246] (30-030305-00) BW750 (Steel Elastomer) (30-029292-00) KM5001 [190] (40-029292-00)	DW756 (21-29292-23/0)	ER320 [26] (22-29293-00/0) ER321 [201] (22-29294-00/0)
14 K2F	1396	4	75.00	MPi, SOHC			
400 414 01/93 → 04/95 43					BW5750 (MLS) [246] (30-030305-00) BW750 (Steel Elastomer) (30-029292-00) KM5001 [190] (40-029292-00)	DW5757 [247] (21-30305-00/0) DW5759 ☒ ○ [246] [247] DW757 (21-29292-24/0) DW759 ☒ ○	ER320 [26] (22-29293-00/0) ER321 [201] (22-29294-00/0)
400 414 GSi/SI 04/90 → 04/95							
400 414 Si 05/95 → 03/00							
14 K4C	1396	4	75.00	SPi, DOHC	66-70/ 90-95		
14 K4D	1396	4	75.00	SPi, DOHC	75/77		
14 K4F	1396	4	75.00	MPi, DOHC	76/103		
400 1.6L i 05/94 → 11/98 44					BW5750 (MLS) [246] (30-030305-00) BW750 (Steel Elastomer) (30-029292-00) KM5001 [190] (40-029292-00)	DW5757 [247] (21-30305-00/0) DW5759 ☒ ○ [246] [247] DW757 (21-29292-24/0) DW759 ☒ ○	ER322 (22-29294-01/0)
400 416 Si 05/95 → 03/00							
16 K4F	1588	4	80.00	MPi, DOHC	110/110		
16 K4F	1588	4	80.00		110/150		
400 1.6L i 05/94 → 11/98 45					BS880 (Graphite) (30-028150-00)	DS881 (21-28150-20/0)	GS881
400 416 GTI 04/90 → 04/95							
400 416 GTI/GTE 04/90 → 04/95							
D 16 A8	1590	4	75.00	Injection, DOHC	90/122		
D 16 A9	1590	4	75.00		96/131		

								
HBS305 Ⓢ (22-89007B) M11x1.50x162mm (x10)	JC950 ■ (31-029333-00) JC949 ■ JC909 ■ (31-029335-00)	LB162 ■ (Rubber/Metal) →12/94 LB161 ■ (Rubber/Metal) →12/94 JM5045 ■ (50-029331-00) (Rubber) 01/95→ LB536 ■ (Rubber)	JJ446 →12/94 JH5022 (50-029271-00) 01/95→	HR802 ■ Green →12/94 HR656 ■ (x2) (24-31939-70/0) Black 01/94→	NB775 (x4) 40x52x7mm, FPM 01/95→12/94 NB774 ■ 35x45x7mm, FPM (50-319419-00) NB843 ■ [3] 128x145x28mm, FPM (50-319420-00)			 AB5400  BS860  BS880  BW5750  BW750  BZ440, BZ450, BZ460  JC674  JC852  JC877  JC907  JC909  JC949  JC950  JD311  JD654  JD655  JD656  JD657  JM5045  JN925
HBS282 Ⓢ (22-72002B) M11x1.50x230mm (x10)	JD657	JP097	JH5012	HR5051 ■	NB775 ■ (x2) 40x52x7mm, FPM NB774 ■ 35x45x7mm, FPM (50-319419-00) NB843 ■ [3] 128x145x28mm, FPM (50-319420-00) →Ch.YD471564 LK5002 ■ [3] 136x153x21mm, PTFE (50-319427-00) Ch.YD471565→			 JN963  JP065  JP097  LB161  LB162  LB536  JH5012  JH5016  JH5022  JJ309  JJ404  JJ446
HBS005 Ⓢ (22-89005B) M9x1.25x412mm (x10)	JD655 ■ (31-029301-00) JD656 ■ (31-029298-00) JD654 ■ (31-029299-00)	JP065 (31-029296-00) (Rubber/Metal)	JH5016 [201] (50-029294-00) JJ404 [26] (50-029293-00)	HR656 ■ (24-31939-70/0)	NC065 ■ 30x40x7mm, FPM (50-306142-00) Black NB998 ■ 30x40x7mm, FPM (50-319402-00) Brown NB828 ■ 27.5x39.5x7mm, FPM (50-319399-00) NB829 ■ 79.95x116x11.5mm, FPM (50-319400-00)			 JH5016  JH5022  JJ309  JJ404  JJ446
HBS005 Ⓢ (22-89005B) M9x1.25x412mm (x10)	JD311 ■ [192] (50-029305-00) (FPM) JC907 ■ [217] (31-029302-00) JC877 ■ [217] (31-029303-00) JC852 ■ (31-029304-00)	JN963 (31-029297-00)	JH5016 [201] (50-029294-00) JJ404 [26] (50-029293-00)	HR752 ■ (24-31939-80/0)	NC065 ■ (x2) 30x40x7mm, FPM (50-306142-00) Black NB998 ■ (x2) 30x40x7mm, FPM (50-319402-00) Brown NB828 ■ 27.5x39.5x7mm, FPM (50-319399-00) NB829 ■ 79.95x116x11.5mm, FPM (50-319400-00)			 JD654  JD655  JD656  JD657  JM5045  JN925
HBS005 Ⓢ (22-89005B) M9x1.25x412mm (x10)	JD311 ■ [192] (50-029305-00) (FPM) JC852 ■ (31-029304-00)	JN963 (31-029297-00)		HR752 ■ (24-31939-80/0)	NC065 ■ (x2) 30x40x7mm, FPM (50-306142-00) Black NB998 ■ (x2) 30x40x7mm, FPM (50-319402-00) Brown NB828 ■ 27.5x39.5x7mm, FPM (50-319399-00) NB829 ■ 79.95x116x11.5mm, FPM (50-319400-00)			 JD654  JD655  JD656  JD657  JM5045  JN925
	JC674 ■	JN925	JJ309	PB156 ■ (x8)	NJ381 ■ 31x46x8mm, NBR NJ312 ■ 80x100x10mm, MVQ			



KW/PS

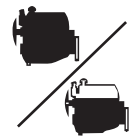

400 416 GSI		04/90 → 04/95		46		BV350 (Graphite) (30-028143-00)		DV351 (21-28143-21/0) 01/92 →	
400 416 GSI/GSE		04/90 → 04/95		46		BV350 (Graphite) (30-028143-00)		DV351 (21-28143-21/0) 01/92 →	
D 16 Z2	1590	4		Injection, SOHC	82/111				
D 16 A7	1590	4	75.00		85/116				
400 1.8L i		06/96 → 11/98		47		BW5750 (MLS) [246] (30-030305-00) BW750 (Steel Elastomer) (30-029292-00) KM5001 [190] (40-029292-00)		DW754 (21-29292-21/0)	
18 K4K (VVC)	1796	4	80.00	MPi, DOHC	86/ 146- 160				ER322 (22-29294-01/0)
400 1.8L TD Diesel		09/93 → 11/98		48		BR780 (Fibre), 1.65mm, 2 Notches →0.65 → 0.77mm BR790 (Fibre), 1.80mm, 3 Notches (30-026855-10) →0.77 → 0.82mm		DJ720▲ (21-25202-22/0)	
400 418 TD Diesel		09/91 → 04/95		48 <td colspan="2">BR780 (Fibre), 1.65mm, 2 Notches →0.65 → 0.77mm BR790 (Fibre), 1.80mm, 3 Notches (30-026855-10) →0.77 → 0.82mm</td> <td colspan="2">DJ720▲ (21-25202-22/0)</td>		BR780 (Fibre), 1.65mm, 2 Notches →0.65 → 0.77mm BR790 (Fibre), 1.80mm, 3 Notches (30-026855-10) →0.77 → 0.82mm		DJ720▲ (21-25202-22/0)	
XUD 7TE	1769	4	80.00		44/66/ 60/90				EL890 (22-25198-01/0) GJ720▲ (20-25202-02/0)
400 418 D Diesel		09/91 → 04/95		49		BX880 (Fibre), 1.36mm, 1 Notch (30-028475-00) →0.56 → 0.67mm BX890 (Fibre), 1.40mm, 2 Notches (30-028476-00) →0.68 → 0.71mm BX900 (Fibre), 1.44mm, 3 Notches (30-028477-00) →0.72 → 0.75mm BX910 (Fibre), 1.48mm, 4 Notches (30-028478-00) →0.76 → 0.79mm BX920 (Fibre), 1.52mm, 5 Notches (30-028479-00) →0.80 → 0.83mm		DJ720▲ (21-25202-22/0)	
400 418 D Diesel		09/91 → 04/95		49 <td colspan="2">BX880 (Fibre), 1.36mm, 1 Notch (30-028475-00) →0.56 → 0.67mm BX890 (Fibre), 1.40mm, 2 Notches (30-028476-00) →0.68 → 0.71mm BX900 (Fibre), 1.44mm, 3 Notches (30-028477-00) →0.72 → 0.75mm BX910 (Fibre), 1.48mm, 4 Notches (30-028478-00) →0.76 → 0.79mm BX920 (Fibre), 1.52mm, 5 Notches (30-028479-00) →0.80 → 0.83mm</td> <td colspan="2">DJ720▲ (21-25202-22/0)</td>		BX880 (Fibre), 1.36mm, 1 Notch (30-028475-00) →0.56 → 0.67mm BX890 (Fibre), 1.40mm, 2 Notches (30-028476-00) →0.68 → 0.71mm BX900 (Fibre), 1.44mm, 3 Notches (30-028477-00) →0.72 → 0.75mm BX910 (Fibre), 1.48mm, 4 Notches (30-028478-00) →0.76 → 0.79mm BX920 (Fibre), 1.52mm, 5 Notches (30-028479-00) →0.80 → 0.83mm		DJ720▲ (21-25202-22/0)	
XUD9 A/B/L/Y	1905	4	83.00		52/71				EL890 (22-25198-01/0) GJ720▲ (20-25202-02/0)
400 2.0L i		05/94 → 11/98		50		BS790 (Fibre) →12/94 AB5400 (MLS) (30-029270-00) 01/95 →		DS792 [221] [222] →12/94 DS795 [222] [223] →12/94 DS797 [221] [224] 01/94 → CB5400 (21-29270-20/0) 01/95 →	
400 420 GSI/SLI/GTI/Vite		01/93 → 04/95		50 <td colspan="2">BS790 (Fibre) →12/94 AB5400 (MLS) (30-029270-00) 01/95 →</td> <td colspan="2">DS792 [221] [222] →12/94 DS795 [222] [223] →12/94 DS797 [221] [224] 01/94 → CB5400 (21-29270-20/0) 01/95 →</td>		BS790 (Fibre) →12/94 AB5400 (MLS) (30-029270-00) 01/95 →		DS792 [221] [222] →12/94 DS795 [222] [223] →12/94 DS797 [221] [224] 01/94 → CB5400 (21-29270-20/0) 01/95 →	
400 420 GTI/GSI/Vitesse		02/92 → 04/95		50 <td colspan="2">BS790 (Fibre) →12/94 AB5400 (MLS) (30-029270-00) 01/95 →</td> <td colspan="2">DS792 [221] [222] →12/94 DS795 [222] [223] →12/94 DS797 [221] [224] 01/94 → CB5400 (21-29270-20/0) 01/95 →</td>		BS790 (Fibre) →12/94 AB5400 (MLS) (30-029270-00) 01/95 →		DS792 [221] [222] →12/94 DS795 [222] [223] →12/94 DS797 [221] [224] 01/94 → CB5400 (21-29270-20/0) 01/95 →	
20 T4H	1994	4	84.45	injection	100/136				ES790 →12/94 EB5400 [12] (22-29271-00/0) 01/95 →
20 M4F	1994	4	84.50	Injection, DOHC	103/140				
400 420 Si Lux		12/95 → 03/00		51		AB5400 (MLS) (30-029270-00)		CB5400 (21-29270-20/0)	
400 420 Si Lux		12/95 → 03/00		51 <td colspan="2">AB5400 (MLS) (30-029270-00)</td> <td colspan="2">CB5400 (21-29270-20/0)</td>		AB5400 (MLS) (30-029270-00)		CB5400 (21-29270-20/0)	
20 T4H	1994	4	84.45	injection	100/136				EB5400 [12] (22-29271-00/0)







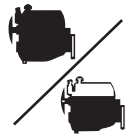



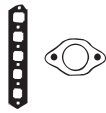

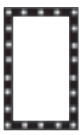

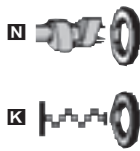

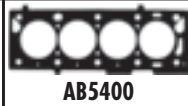
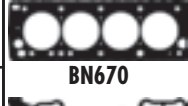
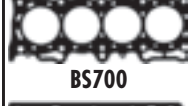







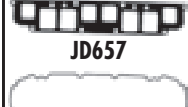





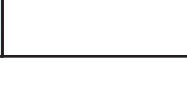







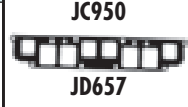
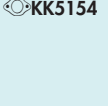





		JD075 JD052 JF024 (x2) JE625	JN744		PB355 (x8) PB356 (x8)	NJ313 29x45x8mm, ACM NK159	
HBS005 (22-89005B) M9x1.25x412mm (x10)	JD564 (31-029307-00) JD563 (31-029306-00) JC852 (31-029304-00)	JN963 (31-029297-00)		HR752 (24-31939-80/0)	NC065 (x2) 30x40x7mm, FPM (50-306142-00) Black NB998 (x2) 30x40x7mm, FPM (50-319402-00) Brown NB828 27.5x39.5x7mm, FPM (50-319399-00) NB829 79.95x116x11.5mm, FPM (50-319400-00)		 AB5400 JN963 BR780, BR790 LB161 BS790 LB162 BV350 LB536 BW5750 JH5022 BW750 JJ283 BX880, BX890, BX900, BX910, BX920 JC852 JJ446
HBS084 (22-15005B) M12x1.50x123mm (x10)	JC991 (31-028595-00)	JN544 (50-025202-00)	JJ283 [6] (31-025198-10) PA349 (33-102290-10) 22x16x2mm	HR569 24-30667-00/0	NF746 36x50x7mm, ACM (50-306399-00) NA5191 42x62x7mm, PTFE (50-319500-00) NA5192 90x110x7mm, PTFE (50-319501-00)		 BX880, BX890, BX900, BX910, BX920 JC852 JC909 JC949 JC950 JC991 JD052 JD075 JD563 JD564 JM5045 JN544 JN744
HBS084 (22-15005B) M12x1.50x123mm (x10)		JN544 (50-025202-00)	JJ283 [6] (31-025198-10) PA349 (33-102290-10) 22x16x2mm	HR569 24-30667-00/0	NF841 (x2) 35x50x8mm, FPM (50-319310-00) NA5191 42x62x7mm, PTFE (50-319500-00) NA5192 90x110x7mm, PTFE (50-319501-00)	HL5010 [245]	
HBS305 (22-89007B) M11x1.50x162mm (x10)	JC950 (31-029333-00) JC949 JC909 (31-029335-00)	LB162 (Rubber/Metal) →12/94 LB161 (Rubber/Metal) →12/94 JM5045 (50-029331-00) (Rubber) 01/95→ LB536 (Rubber)	JJ446 →12/94 JH5022 (50-029271-00) 01/95→	HR802 Green →12/94 HR656 (x2) (24-31939-70/0) Black 01/94→	NB775 (x4) 40x52x7mm, FPM NB774 35x45x7mm, FPM (50-319419-00) NB843 [3] 128x145x28mm, FPM (50-319420-00)		 JD075 JD563 JD564 JM5045 JN544 JN744
HBS305 (22-89007B) M11x1.50x162mm (x10)	JC950 (31-029333-00) JC949 JC909 (31-029335-00)	JM5045 (50-029331-00) (Rubber) LB536 (Rubber)	JH5022 (50-029271-00)	HR656 (x2) (24-31939-70/0)	NB775 (x2) 40x52x7mm, FPM NB774 35x45x7mm, FPM (50-319419-00) NB843 [3] 128x145x28mm, FPM (50-319420-00)		

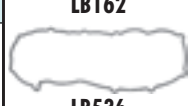
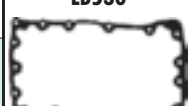

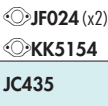
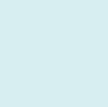
KW/PS



400 420 Turbo				01/93 → 04/95		52		BS860 (Fibre) →12/94 AB5400 (MLS) (30-029270-00) 01/95 →		DS860 [222] [223] →12/94 DS862 [221] [222] →12/94 CB5400 (21-29270-20/0) 01/95 →		ES790 →12/94 EB5400 [12] (22-29271-00/0) 01/95 →	
20 T4G	1994	4	84.45			100/136							
400 420 D Diesel				11/95 → 03/00		53		BZ440 (MLS), 1.05mm, 1 Hole (30-029569-00)		DZ440▲ (21-29569-20/0)		EZ440 [12] (22-29569-00/0) →Ch.YD471063 EZ441 [12] (22-29569-01/0) Ch.YD471064 →	
400 420 Di Diesel				05/95 → 03/00				BZ450 (MLS), 1.20mm, 2 Holes (30-029570-00)					
20 T2R (L Series)	1994	4	84.45	Direct Injection, SOHC		63/86							
20 T2N (L Series)	1994	4	84.45	EFI, SOHC		74-83/ 101- 113							
600 618 i/Si				03/96 → 02/99		54		BS700 (MLS) (30-028118-00)		DS700 (21-28118-20/0)			
F 18 A3	1849	4	85.00	SOHC		83/113							
600 620 i				08/93 → 06/96		55		BS700 (MLS) (30-028118-00)		DS700 (21-28118-20/0)			
600 620 Si				08/93 → 02/99									
F 20 Z2	1997	4	85.00	Injection		85/115							
F 20 Z1	1997	4	85.00	Injection, SOHC		96/131							
600 620 Sdi Diesel				12/94 → 02/99		56		BZ440 (MLS), 1.05mm, 1 Hole (30-029569-00)		DZ440▲ (21-29569-20/0)		EZ440 [12] (22-29569-00/0)	
20 T2N (L Series)	1994	4	84.45	EFI, SOHC		74-83/ 101- 113							
600 620 Ti Vitesse				07/94 → 02/99		57		BS860 (Fibre) →12/94 AB5400 (MLS) (30-029270-00) 01/95 →		DS860 [222] [223] →12/94 DS862 [221] [222] →12/94 CB5400 (21-29270-20/0) 01/95 →		ES790 →12/94 EB5400 [12] (22-29271-00/0) 01/95 →	
20 T4G	1994	4	84.45			100/136							
600 623 Si				08/93 → 02/99		58		BV030 (MLS) (30-028168-00)		DV030		GV030	
H 23 A3	2259	4	87.00	DOHC		116/158							
800 820				10/88 → 10/91		59		BN670 (Fibre)		DN671		EM682	
M 8	1994	4	84.45			74/100							







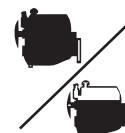



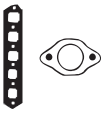

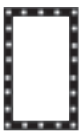

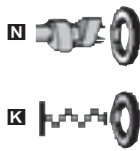































								
HBS305 ⊕ (22-89007B) M11x1.50x162mm (x10)	JC950 ⊕ ⊠ (31-029333-00) JC949 ⊕ ⊠ JC909 ⊕ (31-029335-00)	LB162 ⊕ (Rubber/Metal) →12/94 LB161 ⊕ (Rubber/Metal) →12/94 JM5045 ⊕ (50-029331-00) (Rubber) 01/95→ LB536 ⊕ (Rubber)	JJ446 →12/94 JH5022 (50-029271-00) 01/95→	HR802 ⊕ Green →12/94 HR656 ⊕ (x2) (24-31939-70/0) Black 01/94→	NB775 (x4) 40x52x7mm, FPM 01/95→12/94 NB774 ⊕ 35x45x7mm, FPM (50-319419-00) NB843 ⊕ [3] 128x145x28mm, FPM (50-319420-00)			 AB5400  BN670  BS700  BS860  BV030  BZ440, BZ450, BZ460  JC435  JC883  JC884  JC909  JC949  JC950  JD657  JM5045  JM5046  JP097  LB161  LB162  LB536  JH5012  JJ315  JJ446
HBS282 ⊕ (22-72002B) M11x1.50x230mm (x10)	JD657	JP097	JH5012	HR5051 ⊕	NB775 ⊕ (x2) 40x52x7mm, FPM NB774 ⊕ 35x45x7mm, FPM (50-319419-00) NB843 ⊕ [3] 128x145x28mm, FPM (50-319420-00) →Ch.YD471063 LK5002 ⊕ [3] 136x153x21mm, PTFE (50-319427-00) Ch.YD471064→			 NA5242 ⊕ 40x52x7mm  NJ134 ⊕ 28x42x8mm
HBS284 ⊕ (22-72003B) M12x1.50x198mm (x1) M12x1.50x163mm (x9)	 KK5154	JM5046			NA5242 ⊕ 40x52x7mm NJ134 ⊕ 28x42x8mm			 NA5242 ⊕ 40x52x7mm  NJ134 ⊕ 28x42x8mm
HBS284 ⊕ (22-72003B) M12x1.50x198mm (x1) M12x1.50x163mm (x9)	 KK5154	JM5046			NA5242 ⊕ 40x52x7mm NJ134 ⊕ 28x42x8mm			 NA5242 ⊕ 40x52x7mm  NJ134 ⊕ 28x42x8mm
HBS282 ⊕ (22-72002B) M11x1.50x230mm (x10)	JD657	JP097	JH5012	HR5051 ⊕	NB775 ⊕ (x2) 40x52x7mm, FPM NB774 ⊕ 35x45x7mm, FPM (50-319419-00) NB843 ⊕ [3] 128x145x28mm, FPM (50-319420-00)			 NB775 ⊕ (x2) 40x52x7mm, FPM  NB774 ⊕ 35x45x7mm, FPM (50-319419-00)  NB843 ⊕ [3] 128x145x28mm, FPM (50-319420-00)
HBS305 ⊕ (22-89007B) M11x1.50x162mm (x10)	JC950 ⊕ ⊠ (31-029333-00) JC949 ⊕ ⊠ JC909 ⊕ (31-029335-00)	LB162 ⊕ (Rubber/Metal) →12/94 LB161 ⊕ (Rubber/Metal) →12/94 JM5045 ⊕ (50-029331-00) (Rubber) 01/95→ LB536 ⊕ (Rubber)	JJ446 →12/94 JH5022 (50-029271-00) 01/95→	HR802 ⊕ Green →12/94 HR656 ⊕ (x2) (24-31939-70/0) Black 01/94→	NB775 (x4) 40x52x7mm, FPM 01/95→12/94 NB774 ⊕ 35x45x7mm, FPM (50-319419-00) NB843 ⊕ [3] 128x145x28mm, FPM (50-319420-00)			 JM5045  JM5046  JP097  LB161  LB162  LB536
HBS284 ⊕ (22-72003B) M12x1.50x198mm (x1) M12x1.50x163mm (x9)	JC883 ⊕ JC884 ⊕  JF024 (x2)  KK5154			PB354 ⊕ (x8) PB353 ⊕ (x8)	NA5242 ⊕ 40x52x7mm NJ134 ⊕ 28x42x8mm			 NA5242 ⊕ 40x52x7mm  NJ134 ⊕ 28x42x8mm
	JC435		JJ315	HR625 ⊕	NB775 ⊕ 40x52x7mm, FPM NB773 ⊕ 46x60x7mm, FPM NB774 ⊕ 35x45x7mm, FPM (50-319419-00) NB772 ⊕ 88.9x104.8x9.52mm, MVQ			 NB775 ⊕ 40x52x7mm, FPM  NB773 ⊕ 46x60x7mm, FPM  NB774 ⊕ 35x45x7mm, FPM (50-319419-00)  NB772 ⊕ 88.9x104.8x9.52mm, MVQ



KW/PS



800 820 16V Turbo					01/92 → 02/99	60	BS860 (Fibre) →12/94 →Eng.128816	DS860 [222] [223] →12/94	ES790 →12/94
800 820 Sport					04/94 → 03/96				
20 T4G	1994	4	84.45			100/136	AB5400 (MLS) (30-029270-00) 01/95 → Eng.128817 →	DS862 [221] [222] →12/94	EB5400 [12] (22-29271-00/0) 01/95 →
T 16	1994	4	84.45	DOHC		100- 147/ 136- 200			
800 820 i/Si					10/88 → 12/91	61	BS790 (Fibre)	DS791 →12/89	EM682
800 820 Si					10/88 → 12/91				
20 HD M 16	1994	4	84.50	Injection		98/133		DS793 01/90 →	
20 HD	1994	4	84.50	Injection		103/140			
800 820 I/SI					01/92 → 02/99	62	BS790 (Fibre) →12/94	DS792 [221] [222] →12/94	ES790 →12/94
800 820e					10/86 → 10/91				
20 T4H	1994	4	84.45	injection		100/136	AB5400 (MLS) (30-029270-00) 01/95 →	DS795 [222] [223] →12/94	EB5400 [12] (22-29271-00/0)
								CB5400 (21-29270-20/0) 01/95 →	
800 820 SE/SI					10/86 → 12/91	63	BS790 (Fibre)		EM682
800 820e					10/86 → 10/91				
20 HS	1994	4	84.50	DOHC		88/120			

								
HBS305  (22-89007B) M11x1.50x162mm (x10)	JC950  (31-029333-00) JC949  JC909  (31-029335-00)	LB162  (Rubber/Metal) →12/94 LB161  (Rubber/Metal) →12/94 JM5045  (50-029331-00) (Rubber) 01/95→ LB536  (Rubber)	JJ446 →12/94 JH5022 (50-029271-00) 01/95→	HR802  Green →12/94 HR656  (x2) (24-31939-70/0) Black 01/94→	NB775 (x4) 40x52x7mm, FPM 01/95→12/94 NB774  35x45x7mm, FPM (50-319419-00) NB843  [3] 128x145x28mm, FPM (50-319420-00)			
HBS305  (22-89007B) M11x1.50x162mm (x10)	JC908  JC909  (31-029335-00)	JN836	JJ315	HR339  (x4) →12/89 HR802  01/90→	NB775  (x4) 40x52x7mm, FPM NB774  35x45x7mm, FPM (50-319419-00) NB772  88.9x104.8x9.52mm, MVQ			
HBS305  (22-89007B) M11x1.50x162mm (x10)	JC950  (31-029333-00) JC949  JC909  (31-029335-00)	LB162  (Rubber/Metal) →12/94 LB161  (Rubber/Metal) →12/94 JM5045  (50-029331-00) (Rubber) 01/95→ LB536  (Rubber)	JJ446 →12/94 JH5022 (50-029271-00) 01/95→	HR802  Green →12/94 HR656  (x2) (24-31939-70/0) Black 01/94→	NB775 (x4) 40x52x7mm, FPM 01/95→12/94 NB774  35x45x7mm, FPM (50-319419-00) NB843  [3] 128x145x28mm, FPM (50-319420-00)			
HBS305  (22-89007B) M11x1.50x162mm (x10)	JC908  JC909  (31-029335-00)	JN836	JJ315	HR339  (x4) →Eng.20H/E83/ 104397 →Eng.20H/E84/ 100120 →Eng.20H/E85/ 101990 →Eng.20H/E86/ 100281 HR802  Eng.20H/E83/ 104398→ Eng.20H/E84/ 100121→ Eng.20H/E85/ 101991→ Eng.20H/E86/ 100282→	NB775 (x4) 40x52x7mm, FPM NB774  35x45x7mm, FPM (50-319419-00) NB772  88.9x104.8x9.52mm, MVQ			



KW/PS



800 825 D/SD Diesel				01/90 → 02/99	64	AY400 (MLS), 1.42mm, 0 Notches [30-028472-00]	DK570▲ [7] [21-25850-21/0]	GK572▲ [8] [20-25850-01/0]
800 Coupe 825 SD Diesel				09/93 → 02/99		BK570 (Fibre), 1.42mm, 0 Notches (x4) [30-025008-20]		
425 SL1RR	2500	4	92.00	Indirect Injection	87/118	AY410 (MLS), 1.52mm, 2 Notches [30-028473-00]		
492 4 SHIRG	2500	4	92.00		87/118	BP260 (Fibre), 1.52mm, 2 Notches (x4) [30-025013-20]		
						AY420 (MLS), 1.62mm, 1 Notch [30-028474-00]		
						BK580 (Fibre), 1.62mm, 1 Notch (x4) [30-025007-20]		
800 825 Si Lux				04/96 → 02/99	65	AB5080 (Steel Elastomer) (x2) [30-029276-00]	CB5080 [21-29276-20/0]	
800 Coupe 825 Si				04/96 → 02/99				
25 K4F	2497	6	80.00	V6	130/177			
800 825 Si/Sterling				10/86 → 12/91	66	BP640 (Graphite) (x2)		
C 25 A1	2494	6			110/150			
C 25 A2	2494	6			123- 127/ 167- 173			
800 827 24V I/SI				01/92 → 02/99	67	BR650 (Graphite) (x2)	DR650 [21-28158-20/0]	
800 827 Si/Sterling				02/88 → 02/99				
800 827 Vitesse				10/88 → 12/91				
800 827 Vitesse/SLI				10/88 → 12/91				
800 Coupe 827 24V				08/92 → 02/99				
C 27 A1	2675	6	87.00	Injection, SOHC, V6	124/168			
C 27 A2	2675	6	87.00	Injection, SOHC, V6	130/177			
Coupe 1.6L 16 V				03/96 → 11/99	68	BW5750 (MLS) [246] [30-030305-00]	DW5757 [247] [21-30305-00/0]	ER322 [22-29294-01/0]
16 K4F	1588	4	80.00	MPi, DOHC	110/110	BW750 (Steel Elastomer) [30-029292-00]	DW5759☒○ [246] [247]	
						KM5001 [190] [40-029292-00]	DW757 [21-29292-24/0]	
							DW759☒○	
Coupe 1.8L 16 V				03/96 → 11/99	69	BW5750 (MLS) [246] [30-030305-00]	DW754 [21-29292-21/0]	ER322 [22-29294-01/0]
18 K4K (VVC)	1796	4	80.00	MPi, DOHC	86/ 146- 160	BW750 (Steel Elastomer) [30-029292-00]		
						KM5001 [190] [40-029292-00]		
Maestro 1.3L				09/90 → 01/95	70	AF470 (Fibre) [122] [30-027571-00]	CF474■ [122] DK450■ [123]	EK451
A+ Series	1275	4	70.61		49/67			
A+ Series	1275	4	70.61		51/69	BK450 (Fibre) [123]		

HBS108 Ⓢ [22-56003B] M14x2.0x137mm (x10) M12x1.75x115mm (x4) M12x1.75x79.5mm (x4)	JC928 ■ (x4) (31-025852-10) JD5144 (31-028425-00) JD025 ■ (x4) (31-025849-10) Ⓢ JF123 (31-027523-00)	JP067 (31-025850-10) →01/95 JP068 (31-029626-00) 01/95→									
HBS423 [22-89009B] M9x1.25x200mm (x16)	JD441 ■ (x2) JA5078 ■ (x2) (31-029412-00)	JP007 (x2)		HR5031 ■ (x2) [24-31939-81/0]	■ NC065 ■ (x2) 30x40x7mm, FPM (50-306142-00) Black ■ NB998 ■ (x4) 30x40x7mm, FPM (50-319402-00) Brown ■ NA5083 ■ 32.5x45x7.7mm, FPM (50-319423-00) ■ LK5000 ■ [31 89x116x10.2mm, FPM (50-319424-00)						
	JC687 ■ (x2) Ⓢ JE625 ■	JN633 (x2)	JJ364	PA528 ■ (x12)	■ NJ933 (x2) 35x50x8mm, FPM ■ NK023 ■ 41x56x8mm, ACM ■ NJ675 ■ 80x98x10mm, NBR						
	JC791 ■ (x2) JC687 ■ (x2) Ⓢ JE625 Ⓢ JF021 ■	JN633 (x2)	JJ364	PA528 ■ (x12)	■ NJ933 (x2) 35x50x8mm, FPM ■ NK023 ■ 41x56x8mm, ACM ■ NJ675 ■ 80x98x10mm, NBR						
HBS005 Ⓢ [22-89005B] M9x1.25x412mm (x10)	JD311 ■ [192] (50-029305-00) (FPM) JC852 ■ (31-029304-00)	JN963 (31-029297-00)		HR752 ■ [24-31939-80/0]	■ NC065 ■ (x2) 30x40x7mm, FPM (50-306142-00) Black ■ NB998 ■ (x2) 30x40x7mm, FPM (50-319402-00) Brown ■ NB828 ■ 27.5x39.5x7mm, FPM (50-319399-00) ■ NB829 ■ 79.95x116x11.5mm, FPM (50-319400-00)						
HBS005 Ⓢ [22-89005B] M9x1.25x412mm (x10)	JD564 ■ (x2) (31-029307-00) JD563 ■ (x2) (31-029306-00) JC852 ■ (31-029304-00)	JN963 (31-029297-00)		HR752 ■ [24-31939-80/0]	■ NC065 ■ (x2) 30x40x7mm, FPM (50-306142-00) Black ■ NB998 ■ (x2) 30x40x7mm, FPM (50-319402-00) Brown ■ NB828 ■ 27.5x39.5x7mm, FPM (50-319399-00) ■ NB829 ■ 79.95x116x11.5mm, FPM (50-319400-00)						
	JA439	JM302 (31-027568-00)		HR339 ■ (x2)	■ NA473 ■ 39.7x59x9.5mm, NBR ■ NB291 ■ 82.6x98.7x12.7mm, MVQ						

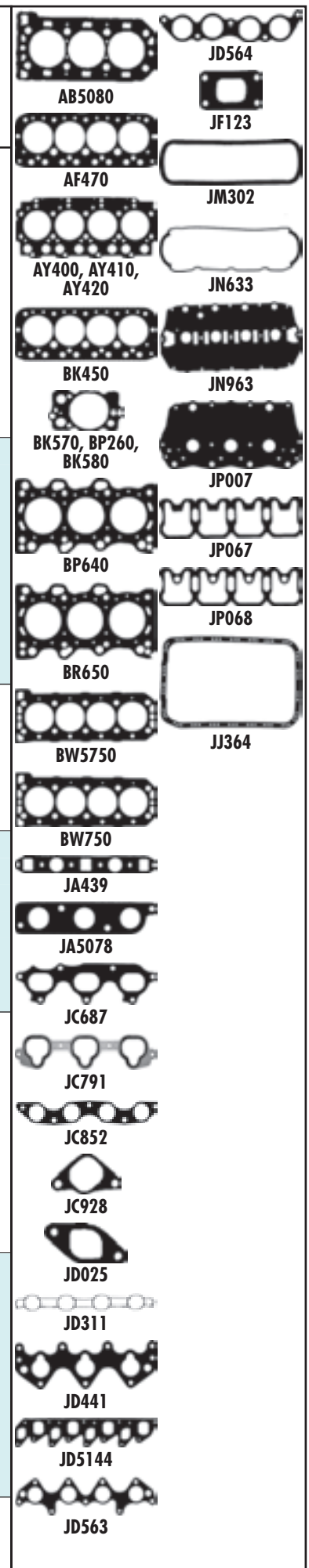



KW/PS

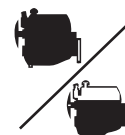

Maestro 2.0L D Diesel				09/90 → 10/92	71	BP880 (Fibre)	DP880 →09/92 DP882 10/92 →	EM685
Prima 65	1994	4	84.45		44/60			
Maestro 2.0L TD Diesel				09/90 → 01/95	72	BP880 (Fibre)	DP881 →09/92 DP883 10/92 →	EM685
Prima 80T	1994	4	84.45		60/82			
Metro 1.1L				05/90 → 12/94	73	BW5750 (MLS) [246] (30-030305-00) BW750 (Steel Elastomer) (30-029292-00) KM5001 [190] (40-029292-00)	DW750 (21-29292-20/0)	ER320 [26] (22-29293-00/0)
11 K2A	1120	4	75.00	Carburettor, SOHC	44/60			
Metro 1.4L				12/90 → 12/94	74	BW5750 (MLS) [246] (30-030305-00) BW750 (Steel Elastomer) (30-029292-00) KM5001 [190] (40-029292-00)	DW756 (21-29292-23/0)	ER320 [26] (22-29293-00/0) ER321 [201] (22-29294-00/0)
14 K2F	1396	4	75.00	MPi, SOHC	55/75			
Metro 1.4L (non cat)				12/90 → 12/94	75	BW5750 (MLS) [246] (30-030305-00) BW750 (Steel Elastomer) (30-029292-00) KM5001 [190] (40-029292-00)	DW750 [218] (21-29292-20/0) DW755 [219] (21-29292-22/0)	ER320 [26] (22-29293-00/0) ER321 [201] (22-29294-00/0)
14 K2D	1396	4	75.00	SPi, SOHC	55/75			
Mini 1.3L				01/91 → 12/91	76	AF470 (Fibre) [122] (30-027571-00) BK450 (Fibre) [123]	CF474 [122] →10/91 DK450 [123] →10/91	EF464 [124]
A Series (12 A2A)	1275	4	70.61		45/61			
Mini 1.3L				01/92 → 04/95	77	AF470 (Fibre) [122] (30-027571-00) BK450 (Fibre) [123]		EF464 [124]
Mini Convertible 1.3L				09/92 → 04/95				
12 A2B	1273	4			37/50			
A+ Series (12 A2D)	1275	4	70.61		39/53			
A Series (12 A2L)	1275	4	70.61	MPi	46/61			
A+ Series (12 A2E)	1275	4	70.61		46/63			
Montego 2.0L D Turbo Diesel				10/88 → 10/95	78	BP880 (Fibre)	DP881 →09/92 DP883 10/92 →	EM685
BB	1996	4		Direct Injection	60/81			







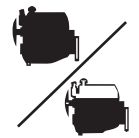



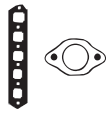

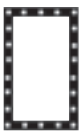

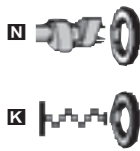

































			JJ315	HR625 →09/92	NB775 40x52x7mm, FPM NB773 46x60x7mm, FPM NB774 35x45x7mm, FPM (50-319419-00) NB772 88.9x104.8x9.52mm, MVQ	AF470 BK450 BP880 BW5750 BW750 JA439 JD654 JD655 JD656 LA564 JM302 JN736 JP065 HC031 JH5016 JJ315 JJ404
			JJ315	HR625 →09/92	NB775 40x52x7mm, FPM NB773 46x60x7mm, FPM NB774 35x45x7mm, FPM (50-319419-00) NB772 88.9x104.8x9.52mm, MVQ	
HBS005 (22-89005B) M9x1.25x412mm (x10)	LA564 JD656 (31-029298-00)	JN736 (50-029295-00) (Rubber)	JJ404 [26] (50-029293-00)	HR656 (24-31939-70/0)	NC065 30x40x7mm, FPM (50-306142-00) NB828 27.5x39.5x7mm, FPM (50-319399-00) NB829 79.95x116x11.5mm, FPM (50-319400-00)	
HBS005 (22-89005B) M9x1.25x412mm (x10)	JD655 JD656 JD654 (31-029299-00)	JP065 (31-029296-00) (Rubber/Metal)	JH5016 [201] (50-029294-00) JJ404 [26] (50-029293-00)	HR656 (24-31939-70/0)	NC065 30x40x7mm, FPM (50-306142-00) Brown NB998 30x40x7mm, FPM (50-319402-00) Brown NB828 27.5x39.5x7mm, FPM (50-319399-00) NB829 79.95x116x11.5mm, FPM (50-319400-00)	
HBS005 (22-89005B) M9x1.25x412mm (x10)	LA564 JD656 JD654 (31-029299-00)	JN736 (50-029295-00) (Rubber) JP065 (31-029296-00) (Rubber/Metal)	JH5016 [201] (50-029294-00) JJ404 [26] (50-029293-00)	HR656 (24-31939-70/0)	NC065 30x40x7mm, FPM (50-306142-00) Black NB998 30x40x7mm, FPM (50-319402-00) Brown NB828 27.5x39.5x7mm, FPM (50-319399-00) NB829 79.95x116x11.5mm, FPM (50-319400-00)	
	JA439	JM302 (31-027568-00)	HC031	HR339 (x2)	NA473 39.7x59x9.5mm, NBR NA584 55x70x10mm, MVQ	NA448 [2] NA301 [2] NB684 [38] HJ013 [39] NB083 [42] [1] [20] JR264 [11] [124]
	JA439	JM302 (31-027568-00)	HC031	HR339 (x2)	NA473 39.7x59x9.5mm, NBR NA584 55x70x10mm, MVQ	NA448 [2] NA301 [2] NB684 [38] HJ013 [39] NB083 [42] [1] [20] JR264 [11] [124]
			JJ315	HR625 →09/92	NB775 40x52x7mm, FPM NB773 46x60x7mm, FPM NB774 35x45x7mm, FPM (50-319419-00) NB772 88.9x104.8x9.52mm, MVQ	
						JJ404



KW/PS



SD1 2400 TD Diesel				05/82 → 10/86		79		
VM 492 HT	2393	4	92.00		67/91	AY400 (MLS), 1.42mm, 0 Notches (30-028472-00) BK570 (Fibre), 1.42mm, 0 Notches (x4) (30-025008-20) AY410 (MLS), 1.52mm, 2 Notches (30-028473-00) BP260 (Fibre), 1.52mm, 2 Notches (x4) (30-025013-20) AY420 (MLS), 1.62mm, 1 Notch (30-028474-00) BK580 (Fibre), 1.62mm, 1 Notch (x4) (30-025007-20)	DK570 ▲ [7] (21-25850-21/0)	GK570 ▲ [36] (20-25850-02/0)
SD1 3500				06/76 → 10/86		80		
38 A/39 A	3528	8	88.86	Carburettor, V8	115/126	AB5480 (Fibre) (x2) [188] AG910 (Steel) (x2)	CG913 ■	EG914
SD1 3500 Vitesse				10/82 → 10/86		81		
30 A	3528	8	88.86	Carburettor, V8	142/163	AB5480 (Fibre) (x2) [188] AG910 (Steel) (x2)	CG915 ■	EG914
31 A	3528	8	88.86	Injection, V8	142/163			
Streetwise 1.4L				08/03 →		82		
14 K4M	1396	4	75.00	MPi, DOHC	62/84	BW5750 (MLS) [246] (30-030305-00) BW750 (Steel Elastomer) (30-029292-00) KM5001 [190] (40-029292-00)	DW5757 [247] (21-30305-00/0) DW5759 ☒☐ [246] [247] DW757 (21-29292-24/0) DW759 ☒☐	ER320 [26] (22-29293-00/0) ER321 [201] (22-29294-00/0)
14 K4F	1396	4	75.00		76/103			
Streetwise 2.0L TD Diesel				08/03 →		83		
20 T2N (L Series)	1994	4	84.45	EFI, SOHC	74-83/ 101- 113	BZ440 (MLS), 1.05mm, 1 Hole (30-029569-00) BZ450 (MLS), 1.20mm, 2 Holes (30-029570-00) BZ460 (MLS), 1.35mm, 3 Holes (30-029571-00)	DZ440 ▲ (21-29569-20/0)	EZ441 [12] (22-29569-01/0)

							
		JC928  (x4) (31-025852-10) JD025  (x4) (31-025849-10)  JF123 (31-027523-00)	JN581 (x4) JP067 (31-025850-10)				NA448  ^[2]
		JB894  JB792  (x8)	JM483 (x2) (31-029717-00)	JH434	HR5052 	 NB849  48.7x63.5x8mm, FPM (50-319467-00)  NB291  82.6x98.7x12.7mm, MVQ	
		JB894  JB792  (x8)	JM483 (x2) (31-029717-00)	JH434	HR5052 	 NB849  48.7x63.5x8mm, FPM (50-319467-00)  NB291  82.6x98.7x12.7mm, MVQ	NA448  ^[2]
HBS005  (22-89005B) M9x1.25x412mm (x10)	JD311  ^[192] (50-029305-00) (FPM) JC907   ^[217] (31-029302-00) JC877   ^[217] (31-029303-00) JC852  (31-029304-00)	JN963 (31-029297-00)	JH5016 ^[201] (50-029294-00) JJ404 ^[26] (50-029293-00)	HR752  (24-31939-80/0)	 NC065  (x2) 30x40x7mm, FPM (50-306142-00) Black  NB998  (x2) 30x40x7mm, FPM (50-319402-00) Brown  NB828  27.5x39.5x7mm, FPM (50-319399-00)  NB829  79.95x116x11.5mm, FPM (50-319400-00)		
HBS282  (22-72002B) M11x1.50x230mm (x10)	JD657	JP097	JH5012	HR5051 	 NB775  (x2) 40x52x7mm, FPM  NB774  35x45x7mm, FPM (50-319419-00)  LK5002  ^[3] 136x153x21mm, PTFE (50-319427-00)		

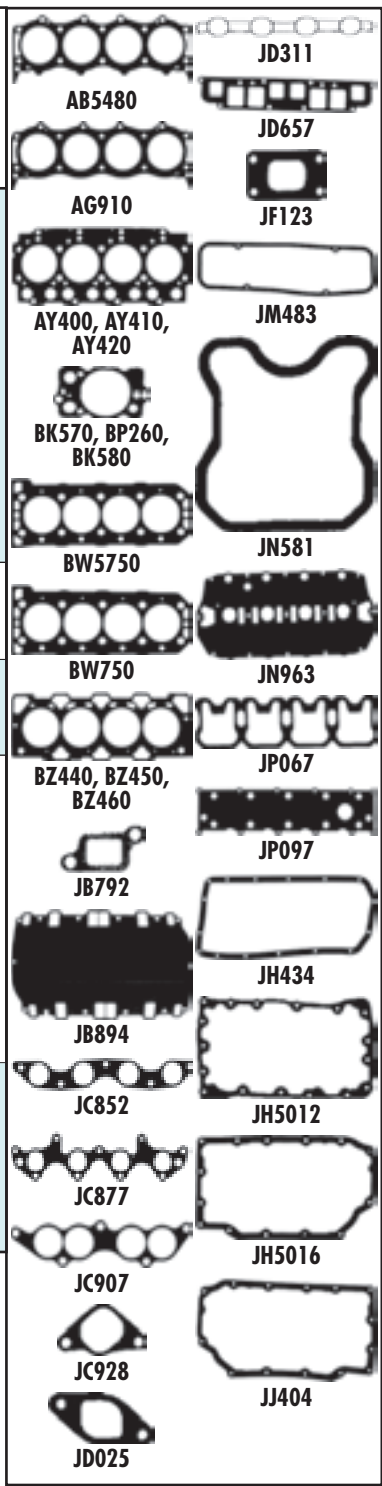



CC



9



CC



9







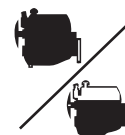



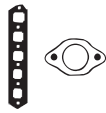

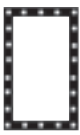

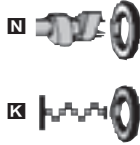

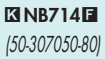
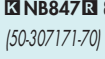





B 20	Petrol	1985	4	90.00	6
B 20 C	Petrol	1985	4	90.00	1
B 20 I	Petrol	1985	4	90.00	1
B201	Petrol	1985	4	90.00	7
B201XC	Petrol	1985	4	90.00	6
B201XI	Petrol	1985	4	90.00	7
B201XL	Petrol	1985	4	90.00	10
B202	Petrol	1985	4		21
B202i	Petrol	1985	4	90.00	17
B202i	Petrol	1985	4	90.00	2
B202i	Petrol	1985	4	90.00	4
B202L	Petrol	1985	4	90.00	12
B202L	Petrol	1985	4	90.00	22
B202S	Petrol	1985	4	90.00	19
B202S	Petrol	1985	4	90.00	9
B202XI	Petrol	1985	4	90.00	16
B202XI	Petrol	1985	4	90.00	3
B202XI (Kat)	Petrol	1985	4	90.00	16
B202XL	Petrol	1985	4	90.00	11
B202XL	Petrol	1985	4	90.00	16
B202XL	Petrol	1985	4	90.00	20
B204E	Petrol	1985	4	90.00	18
B204E	Petrol	1985	4	90.00	19
B204E	Petrol	1985	4	90.00	34
B204I	Petrol	1985	4	90.00	18
B204I	Petrol	1985	4	90.00	34
B204I	Petrol	1985	4	90.00	37
B204I	Petrol	1985	4	90.00	8
B204L	Petrol	1985	4	90.00	34
B204L	Petrol	1985	4	90.00	5
B204R	Petrol	1985	4	90.00	34
B205E	Petrol	1985	4	90.00	36
B205E	Petrol	1985	4	90.00	43
B205L	Petrol	1985	4	90.00	34
B205R	Petrol	1985	4	90.00	36
B206I	Petrol	1985	4		8
B207E	Petrol	1998	4	86.00	31
B207E	Petrol	1998	4	86.00	35
B207L	Petrol	1998	4	86.00	35
B207R	Petrol	1998	4	86.00	35
B212I	Petrol	2119	4	93.00	13
B234E	Petrol	2290	4	90.00	24
B234I	Petrol	1985	4	90.00	14
B234I	Petrol	1985	4	90.00	23
B234I	Petrol	1985	4	90.00	25
B234I	Petrol	1985	4	90.00	27
B234I	Petrol	1985	4	90.00	40
B234L	Petrol	2290	4	90.00	26
B234L	Petrol	2290	4	90.00	27
B234L	Petrol	2290	4	90.00	28
B234R	Petrol	2290	4	90.00	24
B235E	Petrol	2290	4	90.00	45
B235L	Petrol	2290	4	90.00	45
B235R	Petrol	2290	4	90.00	41
B235R	Petrol	2290	4	90.00	45
B258I	Petrol	2498	6	81.60	15
B308E	Petrol	2962	6	86.00	47
B308I	Petrol	2962	6	86.00	29
BI 20	Petrol	1985	4	90.00	7
D223L	Diesel	2171	4	84.00	38
D223L	Diesel	2171	4	84.00	39
D223L	Diesel	2171	4	84.00	44
D308L	Diesel	2958	6	87.50	46
X 22 DTH	Diesel	2171	4	84.00	39
Z18XE	Petrol	1796	4	80.50	30
Z19DT	Diesel	1910	4	82.00	32
Z19DTH	Diesel	1910	4	82.00	33
Z19DTH	Diesel	1910	4	82.00	42



KW/PS

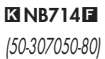
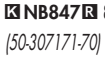
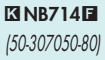
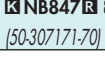
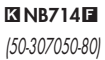
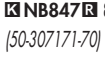
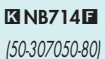
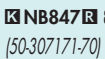
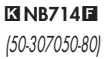
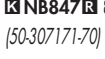
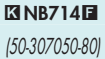
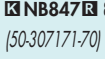

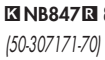
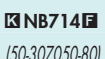
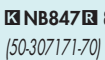
99 2.0L GL						09/74 → 12/84	1	BK610 (Fibre)	DK610○	EC651	
B 20 C	1985	4	90.00	Carburettor	74/100						
B 20 I	1985	4	90.00	Carburettor	74-87/ 100- 118						
900 Cabriolet 2.0L 16v						04/90 → 12/90	2	BT560 (Fibre)	DT561■	ET560	
900 2.0L						10/87 → 10/91		(30-027095-00)	(21-27095-22/0)	(22-27095-00/0)	01/91 →
900 2.0L -16						01/89 → 08/92					
B202i	1985	4	90.00	JH-Jetronic, DOHC	93-96/ 126- 130						
900 2.0L -16						01/86 → 12/88	3	BT560 (Fibre)	DT561■		
B202XI	1985	4	90.00		92-96/ 125- 130		(30-027095-00)	(21-27095-22/0)			
900 2.0L -16						01/89 → 12/93	4	BT560 (Fibre)	DT561■	ET560	
900 Convertible 2.0L -16						01/90 → 06/94		(30-027095-00)	(21-27095-22/0)	(22-27095-00/0)	01/91 → 12/93
B202i	1985	4	90.00	JH-Jetronic, DOHC	93-96/ 126- 130						
900 2.0L -16 Turbo						07/93 → 02/98	5	AC5630 (Fibre)	CC5630■		
900 Convertible 2.0L -16 Turbo						12/93 → 02/98		(30-029532-00)	(21-29532-20/0)		
900 Coupe 2.0L -16 Turbo						12/93 → 02/98					
B204L	1985	4	90.00		136/185						
900 2.0L c						09/79 → 12/88	6	BC650 (Fibre)	DK610○	EC651	
B 20	1985	4	90.00	SOHC	74/100		B 20 BK610 (Fibre)	B201XC	B201XC	B201XC	
B201XC	1985	4	90.00	Carburettor	74/100						
B201XC	1985	4	90.00				B201XC				
900 2.0L EMS						01/79 → 12/80	7	BK610 (Fibre)	DK611○	EC651	
900 2.0L i						11/80 → 08/90					
B201	1985	4	90.00	Injection, SOHC	81/110						
B201XI	1985	4	90.00	SOHC	85/115						
BI 20	1985	4	90.00	Injection, SOHC	85/115						
900 2.0L i						07/93 → 02/98	8	AC5630 (Fibre)	CC5630■		
900 Convertible 2.0L i						12/93 → 02/98		(30-029532-00)	(21-29532-20/0)		
900 Coupe 2.0L i						07/93 → 02/98					
B206I	1985	4		Motronic, DOHC	98/133						
B204I	1985	4	90.00	Injection	96/131						
900 2.0L S Turbo-16						07/91 → 12/93	9	BT560 (Fibre)	DT561■	ET560	
900 Convertible 2.0L S Turbo-16						09/91 → 06/94		(30-027095-00)	(21-27095-22/0)	(22-27095-00/0)	
B202S	1985	4	90.00		104- 110/ 141- 150						
900 2.0L Turbo						01/86 → 12/91	10	BK610 (Fibre)	DK612○		
B201XL	1985	4	90.00		103/140						
B201XL	1985	4	90.00	Injection	110- 114/ 150- 155						

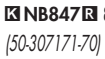





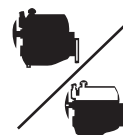



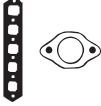

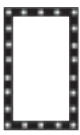

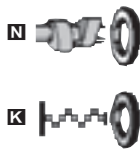















								
HBS179 ® (22-52001B) M12x1.75x121.5mm (x10)	JC305 (x2)	JN513 (50-025723-00)	JJ080 (31-025855-00)		 NB714 48x66.7x10mm, MVQ (50-307050-80)  NB847 88x108x11mm, FPM (50-307171-70)			 AC5630  BC650  BK610  BT560  JC305  JC478  JD348  JD5210  JD5280  JN285  JN513  JJ080
HBS180 ® (22-52002B) M12x1.75x95.5mm (x10)	JD348 (x2) (31-027094-00)	HM5070 (x2) (24-26320-00/0) Eng.G 110407 →		HR646 (x2) 24-30670-60/0	 NB714 48x66.7x10mm, MVQ (50-307050-80)  NB847 88x108x11mm, FPM (50-307171-70)			
HBS179 ® (22-52001B) M12x1.75x121.5mm (x10)	JD348 (x2) (31-027094-00)	HM5070 (x2) (24-26320-00/0)	JJ080 (31-025855-00)	HR646 (x2) 24-30670-60/0	 NB714 48x66.7x10mm, MVQ (50-307050-80)  NB847 88x108x11mm, FPM (50-307171-70)			
HBS180 ® (22-52002B) M12x1.75x95.5mm (x10)	JD348 (x2) (31-027094-00)	HM5070 (x2) (24-26320-00/0) Eng.G 110407 →	JJ080 (31-025855-00)	HR646 (x2) 24-30670-60/0	 NB714 48x66.7x10mm, MVQ (50-307050-80)  NB847 88x108x11mm, FPM (50-307171-70)			
HBS180 ® (22-52002B) M12x1.75x95.5mm (x10)	JC478 (x2) 31-026397-00 JD5210 (x2) (31-027625-00) JD5280 (x2) (31-029795-00)	HM5070 (x2) (24-26320-00/0)	JJ080 (31-025855-00)	HR646 (x2) 24-30670-60/0	 NB714 48x66.7x10mm, MVQ (50-307050-80)  NB847 88x108x11mm, FPM (50-307171-70)			
HBS179 ® (22-52001B) M12x1.75x121.5mm (x10)	JC305 (x2)	JN285 B 20 JN513 (50-025723-00) B201XC	JJ080 (31-025855-00)		 NB714 48x66.7x10mm, MVQ (50-307050-80)  NB847 88x108x11mm, FPM (50-307171-70)			
HBS179 ® (22-52001B) M12x1.75x121.5mm (x10)	JC305 (x2)	JN513 (50-025723-00)	JJ080 (31-025855-00)		 NB714 48x66.7x10mm, MVQ (50-307050-80)  NB847 88x108x11mm, FPM (50-307171-70)			
HBS180 ® (22-52002B) M12x1.75x95.5mm (x10)	JD5210 (x2) (31-027625-00) JD5280 (x2) (31-029795-00)	HM5070 (x2) (24-26320-00/0) G 110407	JJ080 (31-025855-00)	HR646 (x2) 24-30670-60/0	 NB714 48x66.7x10mm, MVQ (50-307050-80)  NB847 88x108x11mm, FPM (50-307171-70)			
HBS180 ® (22-52002B) M12x1.75x95.5mm (x10)	JD348 (x2) (31-027094-00)	HM5070 (x2) (24-26320-00/0) Eng.G52495 →	JJ080 (31-025855-00)	HR646 (x2) 24-30670-60/0	 NB714 48x66.7x10mm, MVQ (50-307050-80)  NB847 88x108x11mm, FPM (50-307171-70)			
HBS179 ® (22-52001B) M12x1.75x121.5mm (x10)	JC305 (x2)	JN513 (50-025723-00)	JJ080 (31-025855-00)		 NB714 48x66.7x10mm, MVQ (50-307050-80)  NB847 88x108x11mm, FPM (50-307171-70)			



KW/PS



900 2.0L Turbo-16 11/85 → 06/94 11						BT560 (Fibre) (30-027095-00)	DT561 ■ (21-27095-22/0)	
900 2.0L Turbo-16 S 01/84 → 12/93								
900 Convertible 2.0L Turbo-16 11/86 → 06/94								
900 Convertible 2.0L Turbo-16 S 11/86 → 06/94								
B202XL	1985	4	90.00	L-Jetronic	118-121/ 160-165			
B202XL	1985	4	90.00	L-Jetronic	125-129/ 170-175			
B202XL	1985	4	90.00	Injection	129/175			
900 2.0L Turbo-16 01/93 → 06/94 12						BT560 (Fibre) (30-027095-00)	DT561 ■ (21-27095-22/0)	ET560 (22-27095-00/0) →12/93
B202L	1985	4	90.00	Motronic, DOHC	132-136/ 180-185			
900 2.1L -16 09/90 → 07/93 13						AC5690 (Fibre)		
900 Convertible 2.1L -16 08/90 → 06/94								
B212I	2119	4	93.00	MPi	100/136			
900 2.3L -16 07/93 → 02/98 14						AC5630 (Fibre) (30-029532-00)	CC5630 ■ (21-29532-20/0)	ET560 (22-27095-00/0)
900 Convertible 2.3L -16 12/93 → 02/98								
900 Coupe 2.3L -16 12/93 → 02/98								
B234I	1985	4	90.00		110/150			
900 2.5L -24 V6 07/93 → 02/98 15						BY270 (Fibre) (x2) (30-027690-00)	DY270 (21-27690-20/0)	
900 Convertible 2.5L -24 V6 12/93 → 02/98								
900 Coupe 2.5L -24 V6 12/93 → 02/98								
B258I	2498	6	81.60	Motronic, DOHC, V6	125/170			
9000 2.0L -16 12/85 → 12/88 16						BT560 (Fibre) (30-027095-00)	DT561 ■ (21-27095-22/0)	
9000 2.0L -16 Turbo 04/85 → 12/91								
9000 2.0L -16 Turbo CD 09/88 → 08/93								
B202XI	1985	4	90.00		92-96/ 125-130			
B202XI (Kat)	1985	4	90.00		92W/125			
B202XL	1985	4	90.00	L-Jetronic	118-121/ 160-165			
B202XL	1985	4	90.00	Injection	129/175			
9000 2.0L -16 01/89 → 01/93 17						BT560 (Fibre) (30-027095-00)	DT561 ■ (21-27095-22/0)	ET560 (22-27095-00/0)
9000 2.0L -16 CS 01/89 → 12/98								
B202i	1985	4	90.00	JH-Jetronic, DOHC	93-96/ 126-130			
9000 2.0L -16 CD 09/93 → 12/98 18						AC5630 (Fibre) (30-029532-00)	CC5630 ■ (21-29532-20/0)	
9000 2.0L -16 CS 09/93 → 12/98								
B204I	1985	4	90.00	Injection	96/131			
B204E	1985	4	90.00	Injection, DOHC	108-113/ 147-154			

								
HBS179 Ⓔ (22-52001B) M12x1.75x121.5mm (x10)	JD348 Ⓔ (31-027094-00)	HM5070 Ⓔ (24-26320-00/0) Eng.G 110407 →	JJ080 (31-025855-00)	HR646 Ⓔ 24-30670-60/0	<input checked="" type="checkbox"/> NB714 Ⓔ 48x66.7x10mm, MVQ (50-307050-80) <input checked="" type="checkbox"/> NB847 Ⓔ 88x108x11mm, FPM (50-307171-70)			 AC5630  AC5690  BT560  BY270  JD348  JD457  JD459  JD5210  JD5280  JM5094  JM5095  JH5052  JJ080
HBS180 Ⓔ (22-52002B) M12x1.75x95.5mm (x10)	JD348 Ⓔ (31-027094-00)	HM5070 Ⓔ (24-26320-00/0) Eng.G 110407 →	JJ080 (31-025855-00)	HR646 Ⓔ 24-30670-60/0	<input checked="" type="checkbox"/> NB714 Ⓔ 48x66.7x10mm, MVQ (50-307050-80) <input checked="" type="checkbox"/> NB847 Ⓔ 88x108x11mm, FPM (50-307171-70)			 JD459  JD5210  JD5280  JM5094  JM5095
	JD5210 Ⓔ (31-027625-00) JD348 Ⓔ (31-027094-00)	HM5070 Ⓔ (24-26320-00/0)	JJ080 (31-025855-00)	HR646 Ⓔ 24-30670-60/0	<input checked="" type="checkbox"/> NB714 Ⓔ 48x66.7x10mm, MVQ (50-307050-80) <input checked="" type="checkbox"/> NB847 Ⓔ 88x108x11mm, FPM (50-307171-70)			 JM5094  JM5095
HBS180 Ⓔ (22-52002B) M12x1.75x95.5mm (x10)	JD5210 Ⓔ (x2) (31-027625-00) JD5280 Ⓔ (31-029795-00)	HM5070 Ⓔ (24-26320-00/0)	JJ080 (31-025855-00)	HR646 Ⓔ 24-30670-60/0	<input checked="" type="checkbox"/> NB714 Ⓔ 48x66.7x10mm, MVQ (50-307050-80) <input checked="" type="checkbox"/> NB847 Ⓔ 88x108x11mm, FPM (50-307171-70)			 JM5095  JH5052  JJ080
HBS164 Ⓔ (22-29011B) M11x1.25x105mm (x16)	JD457 Ⓔ <input checked="" type="checkbox"/> (x2) (31-027686-00) JD459 Ⓔ (x2) (31-027698-00)	JM5094 (x2) (50-027696-00) JM5095 (x2) (50-027697-00)	JH5052 (31-027689-00)	HR5062 Ⓔ 24-30614-73/0	<input checked="" type="checkbox"/> NC006 (x4) 35x48x7mm, MVQ (50-319161-00) <input checked="" type="checkbox"/> NB884 Ⓔ 38x50x5.5mm, FPM (50-319010-00) <input checked="" type="checkbox"/> NB806 Ⓔ 90x104x11mm, FPM (50-306552-00)			 JH5052  JJ080
HBS180 Ⓔ (22-52002B) M12x1.75x95.5mm (x10)	JD348 Ⓔ (31-027094-00)	HM5070 Ⓔ (24-26320-00/0)	JJ080 (31-025855-00)	HR646 Ⓔ 24-30670-60/0	<input checked="" type="checkbox"/> NB714 Ⓔ 48x66.7x10mm, MVQ (50-307050-80) <input checked="" type="checkbox"/> NB847 Ⓔ 88x108x11mm, FPM (50-307171-70)			
HBS180 Ⓔ (22-52002B) M12x1.75x95.5mm (x10)	JD348 Ⓔ (31-027094-00)	HM5070 Ⓔ (24-26320-00/0) Eng.G 110407 →		HR646 Ⓔ 24-30670-60/0	<input checked="" type="checkbox"/> NB714 Ⓔ 48x66.7x10mm, MVQ (50-307050-80) <input checked="" type="checkbox"/> NB847 Ⓔ 88x108x11mm, FPM (50-307171-70)			
HBS180 Ⓔ (22-52002B) M12x1.75x95.5mm (x10)	JD5210 Ⓔ (x2) (31-027625-00) JD5280 Ⓔ (31-029795-00)	HM5070 Ⓔ (24-26320-00/0) Eng.G 52495 →	JJ080 (31-025855-00)	HR646 Ⓔ 24-30670-60/0	<input checked="" type="checkbox"/> NB714 Ⓔ 48x66.7x10mm, MVQ (50-307050-80) <input checked="" type="checkbox"/> NB847 Ⓔ 88x108x11mm, FPM (50-307171-70)			



KW/PS

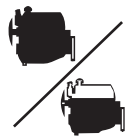

9000 2.0L - 16 ND Turbo					09/93 → 12/98	19	AC5630 (Fibre) (30-029532-00)	CC5630 ■ (21-29532-20/0)	ET560 (22-27095-00/0)
9000 2.0L - 16 Turbo CD					09/92 → 12/98				
B202S	1985	4	90.00			104- 110/ 141- 150			
B204E	1985	4	90.00	Injection, DOHC		108- 113/ 147- 154			
9000 2.0L - 16 Turbo					09/84 → 08/93	20	BT560 (Fibre) (30-027095-00)	DT561 ■ (21-27095-22/0)	
B202XL	1985	4	90.00	L-Jetronic		118- 121/ 160- 165			
B202XL	1985	4	90.00	Injection		129/175			
9000 2.0L - 16 Turbo					06/89 → 12/92	21	BT560 (Fibre) (30-027095-00)	DT561 ■ (21-27095-22/0)	
B202	1985	4				127/172			
9000 2.0L - 16 Turbo CD					09/89 → 12/98	22	BT560 (Fibre) (30-027095-00)	DT561 ■ (21-27095-22/0)	ET560 (22-27095-00/0) 01/91 → 12/93
9000 2.0L - 16 Turbo CS					09/88 → 12/98				
B202L	1985	4	90.00	Motronic, DOHC		132- 136/ 180- 185			
9000 2.3L					10/89 → 01/92	23			ET560 (22-27095-00/0)
B234I	1985	4	90.00			110/150			
9000 2.3L - 16 Aero CS					02/93 → 12/98	24	AC5630 (Fibre) (30-029532-00)	CC5630 ■ (21-29532-20/0)	
9000 2.3L - 16 CDE Eco-Power					09/93 → 12/98				
9000 2.3L - 16 CSE Eco Power					09/93 → 12/98				
B234E	2290	4	90.00	Injection		125/170			
B234R	2290	4	90.00	Injection, DOHC		162- 165/ 220- 225			
9000 2.3L - 16 CD					08/89 → 12/98	25	AC5630 (Fibre) (30-029532-00)	DT562 ■ (21-27095-21/0) → 12/93	ET560 (22-27095-00/0) → 12/93
9000 2.3L - 16 CS					09/89 → 12/98				
9000 2.3L - 16 CSE					09/93 → 12/98				
B234I	1985	4	90.00			110/150	BT560 (Fibre) (30-027095-00) → 12/93		
9000 2.3L - 16 CD Turbo					07/90 → 12/98	26	BT560 (Fibre) (30-027095-00)	DT562 ■ (21-27095-21/0)	ET560 (22-27095-00/0)
9000 2.3L - 16 Turbo					09/90 → 12/98				
B234L	2290	4	90.00			143- 147/ 195- 200	→ 12/93		
9000 2.3L - 16 CDE					09/93 → 12/98	27	AC5630 (Fibre) (30-029532-00)	CC5630 ■ (21-29532-20/0)	ET560 (22-27095-00/0)
9000 2.3L - 16 Turbo CSE					09/93 → 12/98				
B234I	1985	4	90.00			110/150			
B234L	2290	4	90.00			143- 147/ 195- 200			

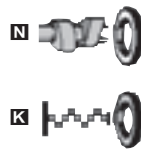
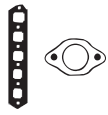

AC560



BT560



JD348



JD5210



JD5280



JJ080











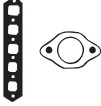

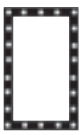

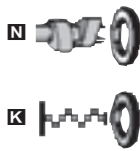















HBS180 ® (22-52002B) M12x1.75x95.5mm (x10)	JD5210 ■ (x2) (31-027625-00) JD5280 ■ (31-029795-00)	HM5070 ■ (24-26320-00/0) Eng.G 52495 →	JJ080 (31-025855-00)	HR646 ■ 24-30670-60/0	NB714 ■ 48x66.7x10mm, MVQ (50-307050-80) NB847 ■ 88x108x11mm, FPM (50-307171-70)	
HBS180 ® (22-52002B) M12x1.75x95.5mm (x10)	JD348 ■ (31-027094-00)	HM5070 ■ (24-26320-00/0) Eng.G 110407 →	JJ080 (31-025855-00)	HR646 ■ 24-30670-60/0	NB714 ■ 48x66.7x10mm, MVQ (50-307050-80) NB847 ■ 88x108x11mm, FPM (50-307171-70)	
HBS180 ® (22-52002B) M12x1.75x95.5mm (x10)	JD348 ■ (31-027094-00)	HM5070 ■ (24-26320-00/0) Eng.G 52495 →	JJ080 (31-025855-00)	HR646 ■ 24-30670-60/0	NB714 ■ 48x66.7x10mm, MVQ (50-307050-80) NB847 ■ 88x108x11mm, FPM (50-307171-70)	
HBS180 ® (22-52002B) M12x1.75x95.5mm (x10)	JD348 ■ (31-027094-00)	HM5070 ■ (24-26320-00/0) Eng.G 52495 →	JJ080 (31-025855-00)	HR646 ■ 24-30670-60/0	NB714 ■ 48x66.7x10mm, MVQ (50-307050-80) NB847 ■ 88x108x11mm, FPM (50-307171-70)	
HBS180 ® (22-52002B) M12x1.75x95.5mm (x10)	JD5210 ■ (x2) (31-027625-00) JD5280 ■ (31-029795-00)	HM5070 ■ (24-26320-00/0) Eng.G 52495 →	JJ080 (31-025855-00)	HR646 ■ 24-30670-60/0	NB714 ■ 48x66.7x10mm, MVQ (50-307050-80) NB847 ■ 88x108x11mm, FPM (50-307171-70)	
HBS180 ® (22-52002B) M12x1.75x95.5mm (x10)	JD5210 ■ (x2) (31-027625-00) JD348 ■ (31-027094-00) →12/93 JD5280 ■ (31-029795-00) 01/94 →	HM5070 ■ (24-26320-00/0) Eng.G 52495 →	JJ080 (31-025855-00)	HR646 ■ 24-30670-60/0	NB714 ■ 48x66.7x10mm, MVQ (50-307050-80) NB847 ■ 88x108x11mm, FPM (50-307171-70)	
HBS180 ® (22-52002B) M12x1.75x95.5mm (x10)	JD5210 ■ (x2) (31-027625-00) JD348 ■ (31-027094-00) →12/93 JD5280 ■ (31-029795-00) 01/94 →	HM5070 ■ (24-26320-00/0) Eng.G 52495 →	JJ080 (31-025855-00)	HR646 ■ 24-30670-60/0	NB714 ■ 48x66.7x10mm, MVQ (50-307050-80) NB847 ■ 88x108x11mm, FPM (50-307171-70)	
HBS180 ® (22-52002B) M12x1.75x95.5mm (x10)	JD5210 ■ (x2) (31-027625-00) JD5280 ■ (31-029795-00)	HM5070 ■ (24-26320-00/0) Eng.G 52495 →	JJ080 (31-025855-00)	HR646 ■ 24-30670-60/0	NB714 ■ 48x66.7x10mm, MVQ (50-307050-80) NB847 ■ 88x108x11mm, FPM (50-307171-70)	



KW/PS



9000 2.3L -16 Turbo				09/90 → 08/93	28	BT560 (Fibre) (30-027095-00)	DT562 ■ (21-27095-21/0)	ET560 (22-27095-00/0)
B234L	2290	4	90.00		143- 147/ 195- 200			
9000 3.0L -24 V6 CD/CDE				07/94 → 12/98	29	BY300 (Fibre) (x2) (30-027849-00)	DY300 (21-27849-20/0)	
9000 3.0L -24 V6 CS/CSE				07/94 → 12/98				
B308I	2962	6	86.00	V6	155/211			
9-3 1.8L i				01/04 →	30	AC5460 (MLS) (30-028674-00)	CC5460 (21-28674-20/0)	
Z18XE	1796	4	80.50	Injection, DOHC	90/122			
9-3 1.8L †				09/02 →	31	AC5630 (Fibre) (30-029532-00)	CC5630 ■ (21-29532-20/0)	
9-3 Convertible 1.8L †				08/03 →				
B207E	1998	4	86.00	Injection, DOHC	110/150			
9-3 1.9L TiD Diesel				09/04 →	32	AY520 (MLS), 1.60mm, 0 Holes (30-029023-10)	CY550 ▲ (21-29023-20/0)	
9-3 TiD Diesel				03/05 →				
Z19DT	1910	4	82.00	Direct Injection	88/120	AY530 (MLS), 1.70mm, 1 Hole (30-029024-10) AY540 (MLS), 1.80mm, 2 Holes (30-029025-10)		
9-3 1.9L TiD Diesel				09/04 →	33	AD5840 (MLS), 0.82mm, 0 Holes (30-029766-00)	CD5840 ▲ (21-29766-20/0)	EE5181 (22-29832-01/0)
9-3 Cabriolet 1.9L TiD Diesel				01/06 →				
Z19DTH	1910	4	82.00	Direct Injection	110/150	AD5850 (MLS), 0.92mm, 1 Hole (30-029767-00) AD5860 (MLS), 1.02mm, 2 Holes (30-029768-00)		
9-3 2.0L i				02/98 → 09/02	34	AC5630 (Fibre) (30-029532-00)	CC5630 ■ (21-29532-20/0)	
9-3 2.0L SE Turbo				02/98 → 09/02				
9-3 2.0L Turbo				02/98 → 09/02				
9-3 Cabriolet 2.0L SE Turbo				02/98 → 08/03				
9-3 Cabriolet 2.0L Turbo				02/98 → 08/03				
B204I	1985	4	90.00	Injection	96/131			
B204E	1985	4	90.00	Injection, DOHC	108- 113/ 147- 154			
B204L	1985	4	90.00		136/185			
B205L	1985	4	90.00	Injection, DOHC	136/185			
B204R	1985	4	90.00	DOHC	147/200			
9-3 2.0L T				09/02 →	35	AC5630 (Fibre) (30-029532-00)	CC5630 ■ (21-29532-20/0)	
9-3 Convertible 2.0L †				08/03 →				
B207E	1998	4	86.00	Injection, DOHC	110/150			
B207L	1998	4	86.00	Injection, DOHC	129/175			
B207R	1998	4	86.00	Injection, DOHC	154/210			
9-3 2.0L Turbo				10/99 → 09/02	36	AE5060 (MLS) (30-029794-00)	CE5060 ■ (21-29794-20/0)	
9-3 Cabriolet 2.0L Turbo				10/99 → 08/03				
B205E	1985	4	90.00	Injection	110/150			
B205R	1985	4	90.00	Injection, DOHC	151/205			







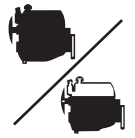



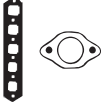

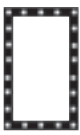

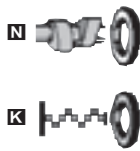

								
HBS180 Ⓢ (22-52002B) M12x1.75x95.5mm (x10)	JD5210 ■ (x2) (31-027625-00) JD348 ■ (31-027094-00)	HM5070 ■ (24-26320-00/0) Eng.G 52495 →	JJ080 (31-025855-00)	HR646 ■ 24-30670-60/0	▣ NB714 ■ 48x66.7x10mm, MVQ (50-307050-80) ▣ NB847 ■ 88x108x11mm, FPM (50-307171-70)			 AC5460  JM5095  JP063
HBS164 Ⓢ (22-29011B) M11x1.25x105mm (x16)	JD5202 ■ (x2) (50-027980-00) JD5203 ■ (x3) (50-027979-00) JD459 ■ (x2) (31-027698-00)	JM5094 (x2) (50-027696-00) JM5095 (x2) (50-027697-00)	JH5052 (31-027689-00)	HR5062 ■ 24-30614-73/0	▣ NC006 (x4) 35x48x7mm, MVQ (50-319161-00) ▣ NB884 ■ 38x50x5.5mm, FPM (50-319010-00) ▣ NB806 ■ 90x104x11mm, FPM (50-306552-00)			 AC5630  AE5060  JH5052  AY520, AY530, AY540  JJ080
HBS055 Ⓢ (22-29012B) M10x1.25x153mm (x10)	JD5196 ■ (31-029039-00) JD5197 ■ (31-029040-00)	JM5092 (50-029087-00)		PA5025 (x16) (50-319386-00) HR5048 ■ (24-31938-60/0)	▣ NC006 (x2) 35x48x7mm, MVQ (50-319161-00) ▣ NC065 ■ 30x40x7mm, FPM (50-306142-00) ▣ NB698 ■ 80x98x10mm, FPM (50-319273-00)			 BT560  BY300  JA5035
HBS416 Ⓢ (22-29025B) M11x1.50x163mm (x10)		HM5070 ■ (24-26320-00/0)	HR397 [57] 34-000410-00					 JD348  JD459  JD468
HBS227 Ⓢ (22-17018B) M12x1.25x218mm (x10)	JA5035 ■ (31-029407-00) JD468 ■ (31-028377-00) (MLS)	JP063		HR363 ■	▣ NA5053 30x42x7mm, FPM (50-319488-00) ▣ NA5070 ■ 31x41x7mm, FPM (50-319524-00)		HL5031 [245]■	 JD5196  JD5197  JD5202
HBS370 Ⓢ (22-17026B) M12x1.25x225mm (x10)	JD5376 ■ (31-029969-00) JE5065 (MLS) JE5066 (MLS)	JM7055 (Steel Elastomer)		HR5095 ■	▣ NA5053 30x42x7mm, FPM (50-319488-00) ▣ NA5070 ■ 31x41x7mm, FPM (50-319524-00)		HL5031 [245]■	 JD5203  JD5210  JD5280  JD5281
HBS180 Ⓢ (22-52002B) M12x1.75x95.5mm (x10)	JD5210 ■ (x2) (31-027625-00) JD5280 ■ (31-029795-00)	HM5070 ■ (24-26320-00/0) Eng.G 110407 → Eng.G 52495 →	JJ080 (31-025855-00)	HR646 ■ 24-30670-60/0	▣ NB714 ■ 48x66.7x10mm, MVQ (50-307050-80) ▣ NB847 ■ 88x108x11mm, FPM (50-307171-70)			 JD5282  JD5376  JM5092  JM5094
HBS416 Ⓢ (22-29025B) M11x1.50x163mm (x10)		HM5070 ■ (24-26320-00/0)	HR397 [57] 34-000410-00					
HBS180 Ⓢ (22-52002B) M12x1.75x95.5mm (x10)	JD5282 ■ (x2) (31-029797-00) JD5281 ■ (x2) (31-029796-00) JD5280 ■ (31-029795-00)	HM5070 ■ (24-26320-00/0)		HR5072 ■ (24-31947-50/0)	▣ NB714 ■ 48x66.7x10mm, MVQ (50-307050-80) ▣ NB847 ■ 88x108x11mm, FPM (50-307171-70)			



KW/PS



9-3 Cabriolet 2.0L i						02/98 → 08/03	37	AC5630 (Fibre) (30-029532-00)	CC5630■ (21-29532-20/0)	
B204I	1985	4	90.00	Injection		96/131				
9-3 2.2L TiD Diesel						11/00 → 09/02	38	AB5671 (MLS), 1.30mm, 1 Notch AB5681 (MLS), 1.40mm, 2 Notches	CB5671▲■ (21-29011-21/0)	EB5670 (22-29011-00/0)
D223L	2171	4	84.00	Direct Injection, SOHC		85-92/ 115- 125				
9-3 2.2L TiD Diesel						02/98 → 11/00	39	AB5671 (MLS), 1.30mm, 1 Notch AB5681 (MLS), 1.40mm, 2 Notches	CB5670▲■ (21-29011-20/0)	EB5670 (22-29011-00/0)
X 22 DTH	2171	4	84.00	Direct Injection		85/115				
D223L	2171	4	84.00	Direct Injection, SOHC		85-92/ 115- 125				
9-3 2.3L i						02/98 → 09/02	40	AC5630 (Fibre) (30-029532-00)	CC5630■ (21-29532-20/0)	ET560 (22-27095-00/0)
9-3 Cabriolet 2.3L i						02/98 → 08/03				
B234I	1985	4	90.00			110/150				
9-3 2.3L Turbo						10/98 → 09/02	41	AE5060 (MLS) (30-029794-00)	CE5060■ (21-29794-20/0)	
9-3 Cabriolet 2.3L Turbo						10/99 → 08/03				
B235R	2290	4	90.00	Injection, DOHC		165- 184/ 224- 250				
9-5 1.9L TiD Diesel						01/06 →	42	AD5840 (MLS), 0.82mm, 0 Holes (30-029766-00) AD5850 (MLS), 0.92mm, 1 Hole (30-029767-00) AD5860 (MLS), 1.02mm, 2 Holes (30-029768-00)	CD5840▲ (21-29766-20/0)	EE5181 (22-29832-01/0)
Z19DTH	1910	4	82.00	Direct Injection		110/150				
9-5 2.0L †						09/97 →	43	AE5060 (MLS) (30-029794-00)	CE5060■ (21-29794-20/0)	
B205E	1985 1985	4 4	90.00	Injection		141/192 110/150				
9-5 2.2L TiD Diesel						03/02 →	44	AB5671 (MLS), 1.30mm, 1 Notch AB5681 (MLS), 1.40mm, 2 Notches	CB5671▲■ (21-29011-21/0)	EB5670 (22-29011-00/0)
D223L	2171	4	84.00	Direct Injection, SOHC		85-92/ 115- 125				
9-5 2.3L †						09/97 →	45	AE5060 (MLS) (30-029794-00)	CE5060■ (21-29794-20/0)	
9-5 2.3L Turbo						10/99 → 09/01				
B235E	2290	4	90.00	Injection, DOHC		125- 136/ 170- 185				
B235L	2290	4	90.00	Injection, DOHC		162- 184/ 220				
B235R	2290	4	90.00	Injection, DOHC		165- 184/ 224- 250				

								 AC5630
HBS180 Ⓢ (22-52002B) M12x1.75x95.5mm (x10)	JD5210 Ⓢ (x2) (31-027625-00) JD5280 Ⓢ (31-029795-00)	HM5070 Ⓢ (24-26320-00/0)	JJ080 (31-025855-00)	HR646 Ⓢ 24-30670-60/0	NB714 Ⓢ 48x66.7x10mm, MVQ (50-307050-80) NB847 Ⓢ 88x108x11mm, FPM (50-307171-70)			 AE5060
HBS298 Ⓢ (22-29016B) M12x1.50x235mm (x10)	JD5255 Ⓢ (31-029721-00) JD5277 Ⓢ (31-029723-00) JD5256 Ⓢ (31-029722-00)	JM5159 (50-029633-00)	JH5057 (31-029575-00)	HR791 Ⓢ 24-30614-76/0	NA5069 Ⓢ 55x68x8mm, FPM (50-319515-00) NA5209 Ⓢ 99x114x11mm, FPM (50-319514-00)			 JD5210
HBS298 Ⓢ (22-29016B) M12x1.50x235mm (x10)	JD5255 Ⓢ (31-029721-00) JD5347 Ⓢ (31-029942-00) JD5256 Ⓢ (31-029722-00)	JM5159 (50-029633-00)	JH5057 (31-029575-00)	HR791 Ⓢ 24-30614-76/0	NA5069 Ⓢ 55x68x8mm, FPM (50-319515-00) NA5209 Ⓢ 99x114x11mm, FPM (50-319514-00)			 JD5255
HBS180 Ⓢ (22-52002B) M12x1.75x95.5mm (x10)	JD5210 Ⓢ (x2) (31-027625-00) JD5280 Ⓢ (31-029795-00)	HM5070 Ⓢ (24-26320-00/0)	JJ080 (31-025855-00)	HR646 Ⓢ 24-30670-60/0	NB714 Ⓢ 48x66.7x10mm, MVQ (50-307050-80) NB847 Ⓢ 88x108x11mm, FPM (50-307171-70)			 JD5256
HBS180 Ⓢ (22-52002B) M12x1.75x95.5mm (x10)	JD5282 Ⓢ (31-029797-00) JD5281 Ⓢ (31-029796-00) JD5280 Ⓢ (31-029795-00)	HM5070 Ⓢ (24-26320-00/0)		HR5072 Ⓢ (24-31947-50/0)	NB714 Ⓢ 48x66.7x10mm, MVQ (50-307050-80) NB847 Ⓢ 88x108x11mm, FPM (50-307171-70)			 JD5277
HBS370 Ⓢ (22-17026B) M12x1.25x225mm (x10)	JD5376 Ⓢ (31-029969-00) JE5065 (MLS) JE5066 (MLS)	JM7055 (Steel Elastomer)		HR5095 Ⓢ	NA5053 30x42x7mm, FPM (50-319488-00) NA5070 Ⓢ 31x41x7mm, FPM (50-319524-00)	HL5031 [245]Ⓢ		 JD5280
HBS180 Ⓢ (22-52002B) M12x1.75x95.5mm (x10)	JD5282 Ⓢ (31-029797-00) JD5281 Ⓢ (31-029796-00) JD5280 Ⓢ (31-029795-00)	HM5070 Ⓢ (24-26320-00/0)		HR5072 Ⓢ (24-31947-50/0)	NB714 Ⓢ 48x66.7x10mm, MVQ (50-307050-80) NB847 Ⓢ 88x108x11mm, FPM (50-307171-70)			 JD5281
HBS298 Ⓢ (22-29016B) M12x1.50x235mm (x10)	JD5255 Ⓢ (31-029721-00) JD5277 Ⓢ (31-029723-00) JD5256 Ⓢ (31-029722-00)	JM5159 (50-029633-00)	JH5057 (31-029575-00)	HR791 Ⓢ 24-30614-76/0	NA5069 Ⓢ 55x68x8mm, FPM (50-319515-00) NA5209 Ⓢ 99x114x11mm, FPM (50-319514-00)			 JD5282
HBS180 Ⓢ (22-52002B) M12x1.75x95.5mm (x10)	JD5282 Ⓢ (31-029797-00) JD5281 Ⓢ (31-029796-00) JD5280 Ⓢ (31-029795-00)	HM5070 Ⓢ (24-26320-00/0)		HR5072 Ⓢ (24-31947-50/0)	NB714 Ⓢ 48x66.7x10mm, MVQ (50-307050-80) NB847 Ⓢ 88x108x11mm, FPM (50-307171-70)			 JD5347



JM5159



JH5057



JJ080







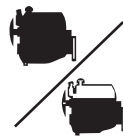



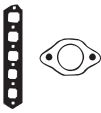

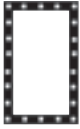

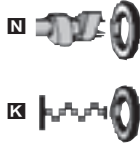





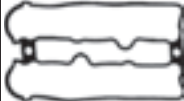

SAAB



















KW/PS



9-5 3.0L TiD Diesel				07/01 →	46		
D308L	2958	6	87.50	Direct Injection, DOHC, V6	130/177	AG9770 (MLS), 0.60mm, 1 Hole <input checked="" type="checkbox"/> AG9780 (MLS), 0.65mm, 2 Holes <input checked="" type="checkbox"/> AG9790 (MLS), 0.70mm, 3 Holes <input checked="" type="checkbox"/> AG9800 (MLS), 0.60mm, 1 Hole <input checked="" type="checkbox"/> AG9810 (MLS), 0.65mm, 2 Holes <input checked="" type="checkbox"/> AG9820 (MLS), 0.70mm, 3 Holes <input checked="" type="checkbox"/>	CG9770 ▲ EG9770 FG9770 ▲
9-5 3.0L V6t				01/98 →	47		
B308E	2962	6	86.00	Injection, DOHC, V6	147/200	BY300 (Fibre) (x2) (30-027849-00)	DY301 (21-27849-21/0)

						 N K		 BY300  JD459  JD5202  JD5203  JD5204
		JD5897  (Steel Elastomer) JD5896   JE5064 (Steel)	HM5292 		HR5094 			
HBS164  (22-29011B) M11x1.25x105mm (x16)	JD5202  (x2) (50-027980-00) JD5203  (x3) (50-027979-00) JD459  (x2) (31-027698-00)	JD5204 (x2) (50-028690-00)		HR5062  24-30614-73/0	NC006 (x4) 35x48x7mm, MVQ (50-319161-00) NB884  38x50x5.5mm, FPM (50-319010-00) NB806  90x104x11mm, FPM (50-306552-00)			

		CC			9			CC			9
021 A.1000	Petrol	1193	4	75.00	115	AEX	Petrol	1390	4	76.50	90
021 A.1000	Petrol	1193	4	75.00	56	AEY	Diesel	1896	4	79.50	41
021 A.2000	Petrol	1461	4	83.00	116	AEY	Diesel	1896	4	79.50	79
021 A.2000	Petrol	1461	4	83.00	64	AEY	Diesel	1896	4	79.50	95
021 B.2000	Petrol	1461	4	83.00	116	AFH	Petrol	1390	4	76.50	26
021 B.2000	Petrol	1461	4	83.00	64	AFH	Petrol	1390	4	76.50	61
021 C.1000	Petrol	1193	4	75.00	115	AFK	Petrol	1390	4	76.50	17
021 C.1000	Petrol	1193	4	75.00	56	AFN	Diesel	1896	4	79.50	138
021 C.2000	Petrol	1461	4	83.00	116	AFN	Diesel	1896	4	79.50	46
021 C.2000	Petrol	1461	4	83.00	64	AFN	Diesel	1896	4	79.50	6
021 D.2000	Petrol	1461	4	83.00	116	AFN	Diesel	1896	4	79.50	84
021 D.2000	Petrol	1461	4	83.00	64	AFT	Petrol	1595	4	81.00	125
09 NCA	Petrol	903	4	65.00	117	AFT	Petrol	1595	4	81.00	34
09 NCA	Petrol	903	4	65.00	50	AFT	Petrol	1595	4	81.00	70
09 NCA	Petrol	903	4	65.00	51	AGG	Petrol	1984	4	82.50	143
09 NCB	Petrol	903	4		117	AGG	Petrol	1984	4	82.50	48
100 GL.7000	Petrol	903	4	65.00	50	AGG	Petrol	1984	4	82.50	87
146 A.000	Petrol	903	4	65.00	51	AGN	Petrol	1781	4	81.00	101
1F	Petrol	1595	4	81.00	124	AGN	Petrol	1781	4	81.00	127
1F	Petrol	1595	4	81.00	32	AGP	Diesel	1896	4	79.50	39
1F	Petrol	1595	4	81.00	68	AGP	Diesel	1896	4	79.50	77
1F	Petrol	1595	4	81.00	92	AGR	Diesel	1896	4	79.50	105
1W	Diesel	1398	4	75.00	119	AGR	Diesel	1896	4	79.50	133
1Y	Diesel	1896	4	79.50	131	AGR	Diesel	1896	4	79.50	42
1Y	Diesel	1896	4	79.50	38	AGR	Diesel	1896	4	79.50	80
1Y	Diesel	1896	4	79.50	76	AGZ	Petrol	2324	5	81.00	145
1Y	Diesel	1896	4	79.50	94	AHB	Diesel	1716	4	79.50	93
1Z	Diesel	1896	4	79.50	137	AHF	Diesel	1896	4	79.50	105
1Z	Diesel	1896	4	79.50	45	AHF	Diesel	1896	4	79.50	133
1Z	Diesel	1896	4	79.50	5	AHT	Petrol	999	4	67.10	15
1Z	Diesel	1896	4	79.50	83	AHU	Diesel	1896	4	79.50	137
2E	Petrol	1984	4	82.50	143	AHU	Diesel	1896	4	79.50	45
2E	Petrol	1984	4	82.50	48	AHU	Diesel	1896	4	79.50	5
2E	Petrol	1984	4	82.50	87	AHU	Diesel	1896	4	79.50	83
AAU	Petrol	1043	4	75.00	53	AHW	Petrol	1390	4	76.50	120
AAV	Petrol	1272	4	75.00	57	AHW	Petrol	1390	4	76.50	97
AAZ	Diesel	1896	4	79.50	131	AJH	Petrol	1781	4	81.00	1
AAZ	Diesel	1896	4	79.50	38	AJQ	Petrol	1781	4	81.00	102
AAZ	Diesel	1896	4	79.50	76	AKK	Petrol	1390	4	76.50	16
ABD	Petrol	1390	4	75.00	25	AKK	Petrol	1390	4	76.50	23
ABD	Petrol	1390	4	75.00	60	AKK	Petrol	1390	4	76.50	58
ABF	Petrol	1984	4	82.50	144	AKL	Petrol	1595	4	81.00	121
ABF	Petrol	1984	4	82.50	49	AKL	Petrol	1595	4	81.00	30
ABF	Petrol	1984	4	82.50	88	AKL	Petrol	1595	4	81.00	65
ABN	Petrol	1595	4	81.00	124	AKL	Petrol	1595	4	81.00	98
ABS	Petrol	1781	4	81.00	130	AKU	Diesel	1716	4	79.50	19
ABS	Petrol	1781	4	81.00	35	AKV	Petrol	1390	4	76.50	16
ABS	Petrol	1781	4	81.00	72	AKV	Petrol	1390	4	76.50	25
ABU	Petrol	1598	4	76.50	33	AKV	Petrol	1390	4	76.50	60
ABU	Petrol	1598	4	76.50	69	AKV	Petrol	1390	4	76.50	90
ADL	Petrol	1781	4	81.00	36	ALD	Petrol	999	4	67.10	15
ADL	Petrol	1781	4	81.00	73	ALD	Petrol	999	4	67.10	20
ADY	Petrol	1984	4	82.50	7	ALD	Petrol	999	4	67.10	52
ADZ	Petrol	1781	4	81.00	130	ALH	Diesel	1896	4	79.50	105
ADZ	Petrol	1781	4	81.00	35	ALH	Diesel	1896	4	79.50	133
ADZ	Petrol	1781	4	81.00	72	ALH	Diesel	1896	4	79.50	42
AEE	Petrol	1598	4	76.50	33	ALH	Diesel	1896	4	79.50	80
AEE	Petrol	1598	4	76.50	69	ALH	Diesel	1896	4	79.50	96
AEE	Petrol	1598	4	76.50	91	ALL	Petrol	999	4	67.10	15
AEH	Petrol	1595	4	81.00	121	ALM	Petrol	1598	4	76.50	29
AEH	Petrol	1595	4	81.00	30	ALM	Petrol	1598	4	76.50	33
AEH	Petrol	1595	4	81.00	65	ALM	Petrol	1598	4	76.50	66
AEH	Petrol	1595	4	81.00	98	ALM	Petrol	1598	4	76.50	69
AER	Petrol	999	4	67.10	15	AMF	Diesel	1422	3	79.50	18
AER	Petrol	999	4	67.10	21	AMF	Diesel	1422	3	79.50	27
AER	Petrol	999	4	67.10	54	AMF	Diesel	1422	3	79.50	62
AEX	Petrol	1390	4	76.50	16	AMK	Petrol	1781	4	81.00	103
AEX	Petrol	1390	4	76.50	25	ANM	Petrol	1390	4	76.50	17
AEX	Petrol	1390	4	76.50	60	ANU	Diesel	1896	4	79.50	5

		CC			9			CC			9
ANV	Petrol	999	4	67.10	15	AUS	Petrol	1598	4	76.50	100
ANV	Petrol	999	4	67.10	20	AUS	Petrol	1598	4	76.50	123
ANV	Petrol	999	4	67.10	52	AUY	Diesel	1896	4	79.50	2
ANW	Petrol	1390	4	76.50	16	AWC	Petrol	1781	4	81.00	1
ANW	Petrol	1390	4	76.50	23	AXP	Petrol	1390	4	76.50	120
ANW	Petrol	1390	4	76.50	58	AXP	Petrol	1390	4	76.50	97
ANX	Petrol	1390	4	76.50	25	AXR	Diesel	1896	4	79.50	107
APE	Petrol	1390	4	76.50	24	AXR	Diesel	1896	4	79.50	44
APE	Petrol	1390	4	76.50	59	AXR	Diesel	1896	4	79.50	81
APE	Petrol	1390	4	76.50	97	AYL	Petrol	2792	6	81.00	8
APF	Petrol	1595	4	81.00	30	AYP	Petrol	1781	4	81.00	74
APF	Petrol	1595	4	81.00	65	AYQ	Diesel	1896	4	79.50	95
APG	Petrol	1781	4	81.00	101	AZD	Petrol	1598	4	76.50	100
APG	Petrol	1781	4	81.00	127	AZD	Petrol	1598	4	76.50	123
APP	Petrol	1781	4	81.00	102	AZL	Petrol	1984	4	82.50	47
APQ	Petrol	1390	4	76.50	16	AZQ	Petrol	1198	3	76.50	22
APQ	Petrol	1390	4	76.50	25	AZQ	Petrol	1198	3	76.50	55
APQ	Petrol	1390	4	76.50	60	AZV	Diesel	1968	4	81.00	110
APQ	Petrol	1390	4	76.50	90	AZV	Diesel	1968	4	81.00	12
AQM	Diesel	1896	4	79.50	104	AZV	Diesel	1968	4	81.00	141
AQM	Diesel	1896	4	79.50	132	BAM	Petrol	1781	4	81.00	103
AQM	Diesel	1896	4	79.50	39	BBU	Petrol	1781	4	81.00	74
AQM	Diesel	1896	4	79.50	77	BBX	Petrol	1984	4	82.50	47
AQQ	Petrol	1390	4	76.50	17	BBY	Petrol	1390	4	76.50	24
AQQ	Petrol	1390	4	76.50	24	BBY	Petrol	1390	4	76.50	59
AQQ	Petrol	1390	4	76.50	59	BBZ	Petrol	1390	4	76.50	24
AQX	Petrol	1781	4	81.00	37	BBZ	Petrol	1390	4	76.50	59
AQX	Petrol	1781	4	81.00	74	BCA	Petrol	1390	4	76.50	97
ARL	Diesel	1896	4	79.50	106	BCB	Petrol	1598	4	76.50	100
ARL	Diesel	1896	4	79.50	134	BCB	Petrol	1598	4	76.50	123
ARL	Diesel	1896	4	79.50	4	BDE	Petrol	2792	6	81.00	113
ARL	Diesel	1896	4	79.50	85	BDE	Petrol	2792	6	81.00	147
ARY	Petrol	1781	4	81.00	102	BGU	Petrol	1595	4	81.00	122
ASK	Diesel	1896	4	79.50	42	BGU	Petrol	1595	4	81.00	9
ASK	Diesel	1896	4	79.50	80	BJB	Diesel	1896	4	79.50	10
ASV	Diesel	1896	4	79.50	105	BJB	Diesel	1896	4	79.50	136
ASV	Diesel	1896	4	79.50	133	BJX	Petrol	1781	4	81.00	74
ASV	Diesel	1896	4	79.50	42	BKC	Diesel	1896	4	79.50	10
ASV	Diesel	1896	4	79.50	80	BKC	Diesel	1896	4	79.50	108
ASY	Diesel	1896	4	79.50	40	BKC	Diesel	1896	4	79.50	136
ASY	Diesel	1896	4	79.50	78	BKD	Diesel	1968	4	81.00	110
ASZ	Diesel	1896	4	79.50	107	BKD	Diesel	1968	4	81.00	12
ASZ	Diesel	1896	4	79.50	135	BKD	Diesel	1968	4	81.00	141
ASZ	Diesel	1896	4	79.50	3	BKV	Petrol	1781	4	81.00	74
ASZ	Diesel	1896	4	79.50	43	BKY	Petrol	1390	4	76.50	59
ASZ	Diesel	1896	4	79.50	82	BLR	Petrol	1984	4	82.50	111
ATD	Diesel	1896	4	79.50	44	BLR	Petrol	1984	4	82.50	13
ATD	Diesel	1896	4	79.50	81	BLR	Petrol	1984	4	82.50	142
ATM	Petrol	1984	4	82.50	7	BLS	Diesel	1896	4	79.50	10
AUA	Petrol	1390	4	76.50	24	BLS	Diesel	1896	4	79.50	108
AUA	Petrol	1390	4	76.50	59	BLS	Diesel	1896	4	79.50	136
AUA	Petrol	1390	4	76.50	89	BLS	Diesel	1896	4	79.50	75
AUB	Petrol	1390	4	76.50	17	BLT	Diesel	1896	4	79.50	43
AUB	Petrol	1390	4	76.50	24	BLT	Diesel	1896	4	79.50	82
AUB	Petrol	1390	4	76.50	59	BLY	Petrol	1984	4	82.50	111
AUC	Petrol	999	4	67.10	15	BLY	Petrol	1984	4	82.50	13
AUC	Petrol	999	4	67.10	20	BLY	Petrol	1984	4	82.50	142
AUC	Petrol	999	4	67.10	52	BME	Petrol	1198	3	76.50	22
AUD	Petrol	1390	4	76.50	16	BMM	Diesel	1968	4	81.00	109
AUD	Petrol	1390	4	76.50	23	BMM	Diesel	1968	4	81.00	11
AUD	Petrol	1390	4	76.50	58	BMM	Diesel	1968	4	81.00	140
AUD	Petrol	1390	4	76.50	90	BMN	Diesel	1968	4	81.00	112
AUE	Petrol	2792	6	81.00	114	BMN	Diesel	1968	4	81.00	139
AUE	Petrol	2792	6	81.00	146	BMN	Diesel	1968	4	81.00	14
AUQ	Petrol	1781	4	81.00	102	BMS	Diesel	1422	3	79.50	28
AUQ	Petrol	1781	4	81.00	103	BMS	Diesel	1422	3	79.50	63
AUQ	Petrol	1781	4	81.00	128	BMT	Diesel	1896	4	79.50	44
AUR	Petrol	1595	4	81.00	30	BMT	Diesel	1896	4	79.50	81
AUR	Petrol	1595	4	81.00	65	BNM	Diesel	1422	3	79.50	28



CC



9



CC



9











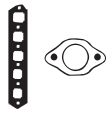

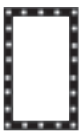

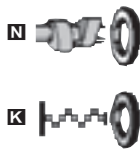
BNM	Diesel	1422	3	79.50	63
BNV	Diesel	1422	3	79.50	28
BNV	Diesel	1422	3	79.50	63
BPX	Diesel	1896	4	79.50	86
BSE	Petrol	1595	4	81.00	122
BSE	Petrol	1595	4	81.00	9
BSE	Petrol	1595	4	81.00	99
BSF	Petrol	1595	4	81.00	122
BSF	Petrol	1595	4	81.00	9
BSF	Petrol	1595	4	81.00	99
BTB	Diesel	1896	4	79.50	4
BTS	Petrol	1598	4	76.50	31
BTS	Petrol	1598	4	76.50	67
BUK	Diesel	1896	4	79.50	86
BVK	Diesel	1896	4	79.50	2
BVY	Petrol	1984	4	82.50	111
BVY	Petrol	1984	4	82.50	13
BVY	Petrol	1984	4	82.50	142
BVZ	Petrol	1984	4	82.50	111
BVZ	Petrol	1984	4	82.50	13
BVZ	Petrol	1984	4	82.50	142
BXE	Diesel	1896	4	79.50	10
BXE	Diesel	1896	4	79.50	108
BXE	Diesel	1896	4	79.50	136
BXV	Petrol	1198	3	76.50	22
BXV	Petrol	1198	3	76.50	55
BZG	Petrol	1198	3	76.50	55
CCSA	Petrol	1595	4	81.00	122
CCSA	Petrol	1595	4	81.00	99
EZ	Petrol	1595	4	81.00	124
KR	Petrol	1781	4	81.00	126
MN	Diesel	1272	4	75.00	118
PL	Petrol	1781	4	81.00	126
RP	Petrol	1781	4	81.00	129



KW/PS



Alhambra 1.8L T 20V					10/97 →	1	AY970 (MLS)	CY971	EY841
AJH	1781	4	81.00	DOHC	110/150		30-028495-00	21-28495-21/0	22-28897-02/0
AWC	1781	4	81.00	Injection, DOHC	110/150				
Alhambra 1.9L TDI Diesel					06/00 →	2	AF5381 (MLS), 1,49mm, 1 Hole	CC5230▲	EB5370 [8]
AUY/BVK	1896	4	79.50	Direct Injection, SOHC	85/115		30-030098-10	21-29463-21/0	22-29314-00/0
							AF5391 (MLS), 1,57mm, 2 Holes 30-030099-10	BVK CC5231▲ 21-29463-20/0	
							AF5401 (MLS), 1,65mm, 3 Holes 30-030100-10	AUY	
Alhambra 1.9L TDI Diesel					11/02 →	3	AF5381 (MLS), 1,49mm, 1 Hole	CC5230▲	EC060 [8]
ASZ	1896	4	79.50	Direct Injection, SOHC	96/130		30-030098-10	21-29463-21/0	22-28897-00/0
							AF5391 (MLS), 1,57mm, 2 Holes 30-030099-10		
							AF5401 (MLS), 1,65mm, 3 Holes 30-030100-10		
Alhambra 1.9L TDI Diesel					05/05 →	4	AF5381 (MLS), 1,49mm, 1 Hole	CC5230▲	EB5370 [8]
ARL/BTB	1896	4	79.50	Direct Injection, SOHC	110/150		30-030098-10	21-29463-21/0	22-29314-00/0
							AF5391 (MLS), 1,57mm, 2 Holes 30-030099-10	BTB CC5231▲ 21-29463-20/0	
							AF5401 (MLS), 1,65mm, 3 Holes 30-030100-10	ARL	
Alhambra 1.9L TDI Diesel					04/96 →	5	BX800 (MLS), 1,45mm, 1 Hole	CC5230▲	EB5370 [8]
IZ	1896	4	79.50		66/89		30-028686-00	21-29463-21/0	22-29314-00/0
AHU	1896	4	79.50	SOHC	66/90		AHU, IZ	ANU	ANU
ANU	1896	4	79.50	Direct Injection, SOHC	66/90		BX810 (MLS), 1,53mm, 2 Holes 30-028687-00	DX800▲ 21-27921-20/0 →Eng.IZ-720 000	EC030 [8] 22-26384-04/0 IZ
							AHU, IZ	AHU	
							BX820 (MLS), 1,61mm, 3 Holes 30-028688-00	DX801▲ 21-27921-21/0 Eng.IZ-720 001 →	
							AHU, IZ		
							AF5381 (MLS), 1,49mm, 1 Hole 30-030098-10		
							ANU		
							AF5391 (MLS), 1,57mm, 2 Holes 30-030099-10		
							ANU		
							AF5401 (MLS), 1,65mm, 3 Holes 30-030100-10		
							ANU		
Alhambra 1.9L TDI Diesel					08/96 → 06/00	6	BX800 (MLS), 1,45mm, 1 Hole	DX800▲	EC030 [8]
AFN	1896	4	79.50	SOHC	81/110		30-028686-00	21-27921-20/0	22-26384-04/0
							BX810 (MLS), 1,53mm, 2 Holes 30-028687-00	→Eng.AFN 002 000	
							BX820 (MLS), 1,61mm, 3 Holes 30-028688-00	DX801▲ 21-27921-21/0 Eng.AFN 002 001 →	

								 AY970	 BX800, BX810, BX820	 JC152	 JD170	 JD600	 JD604	 JD605	 JP003	 JJ609
HBS268 ® (22-33031B) M10x1.50x120mm (x10)	JD604 ■ (31-028824-00) JD605 ■ 31-028826-00 ☞ JF205 (31-025070-00)	HL732 ■ 24-28815-00/0	HR397 [57] 34-000410-00 JH5117 (50-030046-00)	HR822 ■	NA5124 (x2) 32x47x10mm, PTFE (50-319433-00) NA5106 ■ 35x48x10mm, PTFE (50-319430-00) LK5003 ■ [3] 85x131x15.7mm, PTFE (50-319434-00)	HL5040 [245]■										
HBS300 ® (22-33034B) M12x1.75x166mm (x10)	JD170 ■ 31-026556-10 JC152 ■ (x4) 31-026555-00 AUY JD600 ■ 31-028454-00 BVK	JM5203 50-029934-00	HR397 [57] 34-000410-00	HR816 ■ 24-30653-85/0	NA5124 32x47x10mm, PTFE (50-319433-00) NA5106 ■ 35x48x10mm, PTFE (50-319430-00) LK5003 ■ [3] 85x131x15.7mm, PTFE (50-319434-00)	HL5034 [245]■										
HBS300 ® (22-33034B) M12x1.75x166mm (x10)	JD170 ■ 31-026556-10 JD600 ■ 31-028454-00	JM5203 50-029934-00	HR397 [57] 34-000410-00	HR816 ■ 24-30653-85/0	NA5124 32x47x10mm, PTFE (50-319433-00) NA5106 ■ 35x48x10mm, PTFE (50-319430-00) LK5003 ■ [3] 85x131x15.7mm, PTFE (50-319434-00)	HL5034 [245]■										
HBS018 ® (22-39024B) M12x1.75x115mm (x10) ARL HBS300 ® (22-33034B) M12x1.75x166mm (x10) BTB	JD170 ■ 31-026556-10 JC152 ■ (x4) 31-026555-00 ARL JD600 ■ 31-028454-00 BTB	JM5203 50-029934-00	HR397 [57] 34-000410-00	HR816 ■ 24-30653-85/0	NA5124 32x47x10mm, PTFE (50-319433-00) NA5106 ■ 35x48x10mm, PTFE (50-319430-00) LK5003 ■ [3] 85x131x15.7mm, PTFE (50-319434-00)	HL5034 [245]■										
HBS018 ® (22-39024B) M12x1.75x115mm (x10) AHU, 1Z HBS300 ® (22-33034B) M12x1.75x166mm (x10) ANU	JD170 ■ 31-026556-10 AHU, ANU, 1Z JC152 ■ (x4) 31-026555-00 AHU, 1Z JD600 ■ 31-028454-00 ANU	JM5203 50-029934-00 ANU JP003 50-027921-00 AHU, 1Z	HR397 [57] 34-000410-00 ANU JJ609 (50-027500-00) (ACM) AHU, 1Z	HR569 ■ 24-30667-00/0 →Eng.1Z-720 000 AHU HR816 ■ 24-30653-85/0 Eng.1Z-720 001→ ANU	NA5001 32x47x10mm, FPM (50-303185-50) AHU, 1Z NA5124 32x47x10mm, PTFE (50-319433-00) ANU NA5106 ■ 35x48x10mm, PTFE (50-319430-00) ANU NA5001 ■ 32x47x10mm, FPM (50-303185-50) AHU, 1Z LK5003 ■ [3] 85x131x15.7mm, PTFE (50-319434-00) ANU NA5133 ■ 85x105x11mm, FPM (24-30727-87/0) →Eng.AHU 390 000 1Z LK5006 ■ [3] 85x131x16mm, PTFE (50-319448-00) Eng.AHU 390 001→	HL5020 [245]■ AHU, 1Z HL5034 [245]■ ANU NA5278 [54]										
HBS018 ® (22-39024B) M12x1.75x115mm (x10)	JD170 ■ 31-026556-10 JC152 ■ (x4) 31-026555-00	JP003 50-027921-00	JJ609 (50-027500-00) (ACM)	HR569 ■ 24-30667-00/0 →Eng.AFN 002 000 HR816 ■ 24-30653-85/0 Eng.AFN 002 001→	NA5001 32x47x10mm, FPM (50-303185-50) NA5001 ■ 32x47x10mm, FPM (50-303185-50) NA5133 ■ 85x105x11mm, FPM (24-30727-87/0)	HL5020 [245]■ NA5278 [54]										



KW/PS



Alhambra 2.0L i				04/96 →		7		AB5370 (MLS)		CB5370■		EB5370 [8]	
ADY/ATM	1984	4	82.50	Injection, SOHC	85/115			30-029314-00 ATM BY750 (MLS) 30-027930-00 ADY	21-29314-20/0 ATM DY753 21-27930-23/0 ADY		22-29314-00/0 ATM EB970 22-27500-01/0 ADY		
Alhambra 2.8L V6				06/00 →		8		AG5000 (MLS)		CG5030		EG7800	
AYL	2792	6	81.00	Injection, DOHC, V6	150/204			(30-030123-00)	21-30123-30/0				
Altea 1.6L				03/04 →		9		AC5220 (MLS)		CC5222		EC5220 [8]	
BGU/BSE/BSF	1595	4	81.00	Injection, SOHC	75/102			30-029462-00	21-29462-22/0		(22-29462-00/0)		
Altea 1.9L TDI Diesel				04/04 →		10		AF5381 (MLS), 1.49mm, 1 Hole		CC5230▲		EF5380	
BJB/BKC/BLS/BXE	1896	4	79.50	Direct Injection, SOHC	77/105			30-030098-10 AF5391 (MLS), 1.57mm, 2 Holes 30-030099-10 AF5401 (MLS), 1.65mm, 3 Holes 30-030100-10	21-29463-21/0 BJB / BXC / BXE		22-30369-00/0		
Altea 2.0L TDI Diesel				11/05 →		11		AG9630 (MLS), 1.45mm, 1 Hole				EF5380	
Altea 2.0L TDI 4x4 Diesel				06/07 →				30-030349-00				22-30369-00/0	
BMM	1968	4	81.00	Direct Injection, SOHC	103/140			AG9640 (MLS), 1.53mm, 2 Holes AG9650 (MLS), 1.61mm, 3 Holes					
Altea 2.0L TDI Diesel				03/04 →		12		AG8970 (MLS), 1.55mm, 1 Hole				EF5380	
Altea 2.0L TDI 16V Diesel				03/04 →				30-030249-00				22-30369-00/0	
AZV	1968	4	81.00	Direct Injection, DOHC	100/136			AG8800 (MLS), 1.63mm, 2 Holes (30-030213-00)					
BKD	1968	4	81.00	Direct Injection, DOHC	103/140			AG8960 (MLS), 1.71mm, 3 Holes (30-030248-00)					
Altea 2.0L FSI				05/04 →		13		AG9600 (MLS)				EG9600	
BLR/BLY/BVY/BVZ	1984	4	82.50	Injection, DOHC	110/150			30-030352-00			22-30370-00/0		
Altea 2.0L TDI Diesel				03/06 →		14		AG8970 (MLS), 1.55mm, 1 Hole				EF5380	
Altea 2.0L TDI 4WD Diesel				06/07 →				30-030249-00				22-30369-00/0	
BMN	1968	4	81.00	Direct Injection, DOHC	125/170			AG8800 (MLS), 1.63mm, 2 Holes (30-030213-00) AG8960 (MLS), 1.71mm, 3 Holes (30-030248-00)					

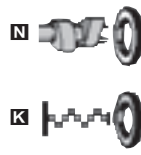
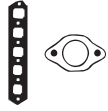

AB5370



AC5220



AG5000

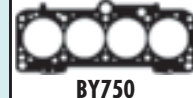

BY750



JC152



JD170



JD483



JD5292



JD5293



JD600



JM5103

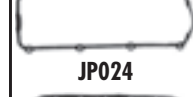

JP024



JJ609









<p>HBS043Ⓢ (22-39001B) M11x1.50x95mm (x10) ADY HBS246Ⓢ (22-33024B) M10x1.50x120mm (x10) ATM</p>	<p>JD483■ (31-027352-00) ADY JD5292■ ■ (31-029815-00) ATM JC152■ (x4) 31-026555-00 ADY JD5293■ (31-029816-00) ATM JF205 (31-025070-00)</p>	<p>JM5103 (50-029547-00) ATM JP024 50-027505-00 ADY JC152■ (x4) 31-026555-00 ADY JD5293■ (31-029816-00) ATM JF205 (31-025070-00)</p>	<p>HR397 [57] 34-000410-00 ATM JJ609 (50-027500-00) (ACM) ADY</p>	<p>HR816■ 24-30653-85/0 NA5001 32x47x10mm, FPM (50-303185-50) ADY NA5124 32x47x10mm, PTFE (50-319433-00) ATM NA5001■ 32x47x10mm, FPM (50-303185-50) ADY NA5106■ 35x48x10mm, PTFE (50-319430-00) ATM LK5006■ [3] 85x131x16mm, PTFE (50-319448-00) ADY NA5133■ 85x105x11mm, FPM (24-30727-87/0) ADY LK5003■ [3] 85x131x15.7mm, PTFE (50-319434-00) ATM</p>	<p>HL5020 [245]■ ADY HL5034 [245]■ ATM</p>
	<p>JD5857■ 50-030160-00 (Rubber)</p>	<p>JM7045 50-030133-00 (Rubber)</p>	<p>HR397 [57] 34-000410-00</p>	<p>HR5062■ 24-30614-73/0 NA5106■ 35x48x10mm, PTFE (50-319430-00)</p>	
<p>HBS246Ⓢ (22-33024B) M10x1.50x120mm (x10)</p>	<p>JD5340■ (x4) (50-029939-00) JD5293■ (31-029816-00)</p>	<p>JM5205 50-029938-00 (Rubber)</p>	<p>HR397 [57] 34-000410-00</p>	<p>HR817■ 24-30614-78/0 NA5124 32x47x10mm, PTFE (50-319433-00) NA5106■ 35x48x10mm, PTFE (50-319430-00) LK5008■ [3] 85x131x15.7mm, PTFE (50-319472-00)</p>	<p>HL5034 [245]■</p>
<p>HBS300Ⓢ (22-33034B) M12x1.75x166mm (x10)</p>	<p>JD170■ 31-026556-10 JD600■ 31-028454-00 BJB / BXC / BXE</p>	<p>JM5203 50-029934-00 BJB / BXC / BXE</p>	<p>HR397 [57] 34-000410-00</p>	<p>HR816■ 24-30653-85/0 NA5124 32x47x10mm, PTFE (50-319433-00) NA5106■ 35x48x10mm, PTFE (50-319430-00) LK5012■ [3] [85] 85x132x15.7mm, ACM (50-319535-00)</p>	<p>HL5034 [245]■</p>
<p>HBS300Ⓢ (22-33034B) M12x1.75x166mm (x10)</p>	<p>JD170■ 31-026556-10</p>		<p>HR397 [57] 34-000410-00</p>	<p>HR816■ 24-30653-85/0 NA5124 32x47x10mm, PTFE (50-319433-00) NA5106■ 35x48x10mm, PTFE (50-319430-00) LK5012■ [3] [85] 85x132x15.7mm, ACM (50-319535-00)</p>	
<p>HBS364Ⓢ (22-39032B) M12x1.75x149mm (x10)</p>	<p>JD5805■ 50-030225-00 JD5806■ 31-030226-00 JD5815■ 31-030235-00</p>	<p>JM7031 50-030223-00 (Rubber)</p>	<p>HR397 [57] 34-000410-00</p>	<p>HR791■ 24-30614-76/0 NA5124 (x2) 32x47x10mm, PTFE (50-319433-00) NA5106■ 35x48x10mm, PTFE (50-319430-00) LK5012■ [3] [85] 85x132x15.7mm, ACM (50-319535-00)</p>	<p>KK5522 [86]</p>
<p>HBS363Ⓢ (22-33038B) M10x1.50x122mm (x10)</p>	<p>JD5873■ 50-030353-00 (FPM) JD5813■ 31-030233-00</p>		<p>HR397 [57] 34-000410-00</p>	<p>HR791■ 24-30614-76/0 NA5124 32x47x10mm, PTFE (50-319433-00) NA5106■ 35x48x10mm, PTFE (50-319430-00) LK5008■ [3] 85x131x15.7mm, PTFE (50-319472-00)</p>	
<p>HBS364Ⓢ (22-39032B) M12x1.75x149mm (x10)</p>	<p>JD5805■ 50-030225-00 JD5806■ 31-030226-00</p>		<p>HR397 [57] 34-000410-00</p>	<p>HR791■ 24-30614-76/0 NA5124 (x2) 32x47x10mm, PTFE (50-319433-00) NA5106■ 35x48x10mm, PTFE (50-319430-00) LK5012■ [3] [85] 85x132x15.7mm, ACM (50-319535-00)</p>	<p>HL5034 [245]■ KK5522 [86]</p>

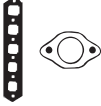

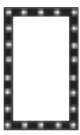
KW/PS

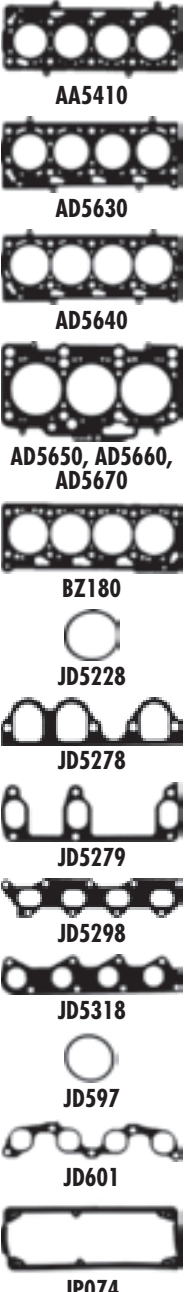

Arosa 1.0L					05/97 → 06/04	15			
AER	999	4	67.10	Injection, SOHC	37/50	AD5630 (MLS), 0.50mm	30-029660-00	CA5410	EB961 [8]
AHT	999	4	67.10	Motronic, OHV	37/50	ALD/ANV/AUC		21-29052-20/0	22-28897-03/0
ALD/ALL/ANV	999	4	67.10	Motronic, SOHC	37/50	AA5410 (MLS), 0.60mm	30-029052-10	AER/ALL	AER/ALL
AUC	999	4	67.10	Injection, SOHC	37/50	AER/ALL		CD5630	
								21-29660-00/0	
								ALD/ANV/AUC	
Arosa 1.4L					05/97 → 06/04	16			
AEX	1390	4	76.50	Injection, SOHC	44/60	BZ180 (MLS), 0.50mm	30-027910-10	CD5640	EB961 [8]
AKK	1390	4	76.50	Motronic, SOHC	44/60	AEX/AKV/APQ		21-29662-20/0	22-28897-03/0
AKV	1390	4	76.50	Injection, SOHC	44/60	AD5640 (MLS), 0.64mm	30-029662-00	AUD/AKK/ANW	→ Eng. AEX 908 121
ANW	1390	4	76.50	MPi, SOHC	44/60	AUD/AKK/ANW		DZ181	→ Eng. AKV 095 009
APQ/AUD	1390	4	76.50	Injection, SOHC	44/60			21-27910-21/0	
								AEX/AKV/APQ	
Arosa 1.4L 16V					01/00 → 06/04	17			
AQQ/AUB	1390	4	76.50	Injection, DOHC	74/100	AB5701 (MLS)	30-029313-10	CB5700	EB5700 [8]
AFK/ANM	1390	4	76.50	Motronic, DOHC	74/101			21-29313-20/0	22-29313-00/0
Arosa 1.4L TDI Diesel					01/00 → 06/04	18			
AMF	1422	3	79.50	Direct Injection, SOHC	55/75	AD5650 (MLS), 1.45mm, 1 Hole	30-029663-00	CD5650	ED5650 [8]
						AD5660 (MLS), 1.53mm, 2 Holes	30-029664-00	21-29671-20/0	(22-29671-00/0)
						AD5670 (MLS), 1.61mm, 3 Holes	30-029665-00		











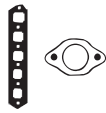

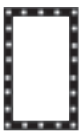

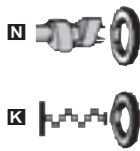























































							
<p>HBS249Ⓢ (22-33025B) M9x1.25x138mm (x10) AER/ALL HBS362Ⓢ (22-39031B) M9x1.25x162mm (x10) ALD/ANV/ANC</p>	<p>JD597■ ■ 50-350355-00 JD5318■ (31-029901-00) ALD/AUC/ANV JD601■ 31-028644-00 AER/ALL  JE5076 (31-028373-00)</p>	<p>JM5285 (50-026659-00) AHT JP074 50-027907-00 AER/ALL</p>	<p>HR397 [57] 34-000410-00 AER/AUD/ALL/ ANV/AUC</p>	<p>HR816■ 24-30653-85/0 AER/ALL HR817■ 24-30614-78/0 ALD/AUC/ANV</p>	<p>■ NA5001 32x47x10mm, FPM (50-303185-50) AER/ALL ■ NA5185 32x42x6mm, FPM (50-319489-00) ALD/AUC/ANV ■ NA5001■ 32x47x10mm, FPM (50-303185-50) →Eng.AER 220 083 ■ NA5133■ 85x105x11mm, FPM (24-30727-87/0) →Eng.AER 220 083 ■ LK5011■ [3] [78] 85x131x15.94mm, PTFE ALD/ANV/AUC ■ NA5185■ 32x42x6mm, FPM (50-319489-00) Eng.AER 220 084 → ALL/ALD/AUC/ANV ■ LK5006■ [3] 85x131x16mm, PTFE (50-319448-00) Eng.AER 220 084 → ALL</p>	<p>HL5020 [245]■ →Eng.AER 220 083 KA5025 [13]</p>	<p>AA5410 AD5630 AD5640 AD5650, AD5660, AD5670 BZ180 JD5228 JD5278 JD5279 JD5298 JD5318 JD597 JD601 JP074</p>
<p>HBS075Ⓢ (22-39011B) M11x1.50x110mm (x10) AEX/AKV/APQ HBS362Ⓢ (22-39031B) M9x1.25x162mm (x10) AUD/AKK/ANW</p>	<p>JD597■ ■ 50-350355-00 JD5318■ (31-029901-00) AUD/AKK/ANW JD601■ 31-028644-00 AEX/AKV/APQ</p>	<p>JP074 50-027907-00 AEX/AKV/APQ HM5062■ 24-27907-00/0 AEX/AKV/APQ</p>	<p>HR397 [57] 34-000410-00</p>	<p>HR816■ 24-30653-85/0 AEX, AKV, APQ HR817■ 24-30614-78/0 AKK, ANW, AUD</p>	<p>■ NA5001 32x47x10mm, FPM (50-303185-50) AEX, AKV, APQ ■ NA5185 32x42x6mm, FPM (50-319489-00) AKK, ANW, AUD ■ NA5001■ 32x47x10mm, FPM (50-303185-50) →Eng.AEX 908 121 →Eng.AKV 095 009 ■ NA5133■ 85x105x11mm, FPM (24-30727-87/0) →Eng.AEX 908 121 →Eng.AKV 095 009 ■ LK5011■ [3] [78] 85x131x15.94mm, PTFE AKK, ANW, AUD ■ NA5185■ 32x42x6mm, FPM (50-319489-00) Eng.AEX 908 122 → Eng.AKV 095 010 → AKK, ANW, APQ, AUD ■ LK5006■ [3] 85x131x16mm, PTFE (50-319448-00) Eng.AEX 908 122 → Eng.AKV 095 010 → APQ</p>	<p>HL5020 [245]■ KA5025 [13]</p>	<p>JD5298 JD5318 JD597 JD601 JP074</p>
<p>HBS249Ⓢ (22-33025B) M9x1.25x138mm (x10)</p>	<p>JD5228■ (x4) (50-029071-00) JD5298■ (31-029825-00)</p>		<p>HR397 [57] 34-000410-00</p>	<p>HR791■ 24-30614-76/0</p>	<p>■ NA5180 27x42x8mm, FPM (50-319484-00) ■ NA5185■ 32x42x6mm, FPM (50-319489-00)</p>	<p>KA5025 [13] KK5551 [81]</p>	
<p>HBS264Ⓢ (22-33026B) M12x1.75x166mm (x8)</p>	<p>JD5278■ (31-029671-00) JD5279■ (31-029710-00)</p>	<p>JM7032 50-030224-00</p>	<p>HR397 [57] 34-000410-00</p>	<p>HR5068■ (24-30653-84/0)</p>	<p>■ NA5124 32x47x10mm, PTFE (50-319433-00) ■ NA5106■ 35x48x10mm, PTFE (50-319430-00) ■ LK5003■ [3] 85x131x15.7mm, PTFE (50-319434-00)</p>	<p>HL5034 [245]■</p>	



KW/PS



Arosa 1.7L SDI Diesel					08/97 → 06/04	19	BX800 (MLS), 1.45mm, 1 Hole 30-028686-00 BX810 (MLS), 1.53mm, 2 Holes 30-028687-00 BX820 (MLS), 1.61mm, 3 Holes 30-028688-00		DX801▲ 21-29721-21/0	EC030 [8] 22-26384-04/0 →Eng.AKU 013 000
AKU	1716	4	79.50	Direct Injection, SOHC	44/60					
Cordoba 1.0L					05/99 → 10/02	20	AD5630 (MLS), 0.50mm 30-029660-00		CD5630 21-29660-00/0	
ALD/ANV	999	4	67.10	Motronic, SOHC	37/50					
AUC	999	4	67.10	Injection, SOHC	37/50					
Cordoba 1.0L i					09/96 → 06/99	21	AA5410 (MLS), 0.60mm 30-029052-10		CA5410 21-29052-20/0	EB961 [8] 22-28897-03/0 →Eng.AER 220 083
AER	999	4	67.10	Injection, SOHC	37/50					
Cordoba 1.2L 12V					05/06 →	22	AF5990 (MLS) (30-030120-00)		CF5990 21-30120-00/0	EF5990 22-30371-00/0
Cordoba 1.2L i					10/02 →					
AZQ	1198	3	76.50	Injection, DOHC	47/64					
BME	1198	3	76.50	Injection, SOHC	47/64					
BXV	1198	3	76.50	Injection, DOHC	51/70					
Cordoba 1.4L					06/99 → 10/02	23	AD5640 (MLS), 0.64mm 30-029662-00		CD5640☒ 21-29662-20/0	
Cordoba 1.4L Vario					06/99 →					
AKK	1390	4	76.50	Motronic, SOHC	44/60					
ANW	1390	4	76.50	MPi, SOHC	44/60					
AUD	1390	4	76.50	Injection, SOHC	44/60					
Cordoba 1.4L 16V					02/00 → 10/02	24	AB5701 (MLS) 30-029313-10		CB5700☒ 21-29313-20/0	EB5700 [8] 22-29313-00/0
Cordoba 1.4L 16V Vario					06/99 →					
APE	1390	4	76.50	MPi, DOHC	55/75					
AUA/BBY	1390	4	76.50	Injection, DOHC	55/75					
AQQ/AUB/BBZ	1390	4	76.50	Injection, DOHC	74/100					







								
HBS018 Ⓢ (22-39024B) M12x1.75x115mm (x10)	JD170 ■ 31-026556-10 JC152 ■ (x4) 31-026555-00	JP003 50-027921-00	JJ609 (50-027500-00) (ACM)	HR816 ■ 24-30653-85/0	NA5001 32x47x10mm, FPM (50-303185-50) NA5001 ■ 32x47x10mm, FPM (50-303185-50) NA5133 ■ 85x105x11mm, FPM (24-30727-87/0) →Eng.AKU 013 000 LK5006 ■ [3] 85x131x16mm, PTFE (50-319448-00) Eng.AKU 013 001→	HL5020 [245]■ NA5278 [54]		 AA5410  AD5630  AD5640  BX800, BX810, BX820  JC152  JD170  JD5228  JD5298  JD5318  JD597  JD601  JP003  JP074  JJ609
HBS362 Ⓢ (22-39031B) M9x1.25x162mm (x10)	JD597 ■ ■ 50-350355-00 JD5318 ■ (31-029901-00) JE5076 (31-028373-00)		HR397 [57] 34-000410-00	HR817 ■ 24-30614-78/0	NA5185 32x42x6mm, FPM (50-319489-00) NA5185 ■ 32x42x6mm, FPM (50-319489-00) LK5011 ■ [3] [78] 85x131x15.94mm, PTFE	KA5025 [13]		 JC152  JD170  JD5228  JD5298  JD5318  JD597  JD601  JP003  JP074  JJ609
HBS249 Ⓢ (22-33025B) M9x1.25x138mm (x10)	JD597 ■ ■ 50-350355-00 JD601 ■ 31-028644-00	JP074 50-027907-00 HM5062 ■ 24-27907-00/0	HR397 [57] 34-000410-00	HR816 ■ 24-30653-85/0	NA5001 32x47x10mm, FPM (50-303185-50) NA5001 ■ 32x47x10mm, FPM (50-303185-50) →Eng.AER 220 083 NA5133 ■ 85x105x11mm, FPM (24-30727-87/0) →Eng.AER 220 083 NA5185 ■ 32x42x6mm, FPM (50-319489-00) Eng.AER 220 084→ LK5006 ■ [3] 85x131x16mm, PTFE (50-319448-00) Eng.AER 220 084→	HL5020 [245]■ →Eng.AER 220 083 KA5025 [13]		 JC152  JD170  JD5228  JD5298  JD5318  JD597  JD601  JP003  JP074  JJ609
HBS471 Ⓢ (22-39035B) M9x1.25x138mm (x8)	JD5811 ■ (x3) (50-030231-00) JD5816 ■ 31-030236-00	HR397 [57] 34-000410-00	HR397 [57] 34-000410-00	HR280 ■ 24-30614-75/0	NA5106 ■ 35x48x10mm, PTFE (50-319430-00)			 JC152  JD170  JD5228  JD5298  JD5318  JD597  JD601  JP003  JP074  JJ609
HBS362 Ⓢ (22-39031B) M9x1.25x162mm (x10)	JD597 ■ ■ 50-350355-00 JD5318 ■ (31-029901-00)		HR397 [57] 34-000410-00	HR817 ■ 24-30614-78/0	NA5185 32x42x6mm, FPM (50-319489-00) NA5185 ■ 32x42x6mm, FPM (50-319489-00) LK5011 ■ [3] [78] 85x131x15.94mm, PTFE	KA5025 [13]		 JC152  JD170  JD5228  JD5298  JD5318  JD597  JD601  JP003  JP074  JJ609
HBS249 Ⓢ (22-33025B) M9x1.25x138mm (x10)	JD5228 ■ (x4) (50-029071-00) JD5298 ■ (31-029825-00)		HR397 [57] 34-000410-00	HR791 ■ 24-30614-76/0	NA5180 27x42x8mm, FPM (50-319484-00) NA5185 ■ 32x42x6mm, FPM (50-319489-00)	KA5025 [13] KK5551 [81]		 JC152  JD170  JD5228  JD5298  JD5318  JD597  JD601  JP003  JP074  JJ609

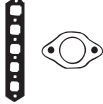

KW/PS

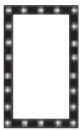

Cordoba 1.4L i		06/94 → 06/99		25				
ABD	1390	4	75.00	Motronic, SOHC	44/60	BZ180 (MLS), 0.50mm 30-027910-10 AEX/AKV/ANX/APQ BL570 (Fibre), 1.73mm 30-024813-20 ABD	DL574 21-24813-27/0 →Eng.ABD 558 154 DZ181 21-27910-21/0 AEX, AKV, ANX, APQ DL573 (21-24813-28/0) Eng.ABD 558 155→	EB961 [8] 22-28897-03/0 →Eng.AEX 908 121 →Eng.AKV 095 008 EV460 22-26516-01/0 ABD
AEX/AKV/ANX/APQ	1390	4	76.50	Injection, SOHC	44/60			
Cordoba 1.4L i 16V		09/96 → 06/99		26				
AFH	1390	4	76.50	Injection, DOHC	74/101	AA5500 (MLS) 30-029042-00	CA5500 21-29042-20/0	EB961 [8] 22-28897-03/0 →Eng.AFH 030 000
Cordoba 1.4L TDI Diesel		10/02 →		27				
AMF	1422	3	79.50	Direct Injection, SOHC	55/75	AD5650 (MLS), 1.45mm, 1 Hole 30-029663-00 AD5660 (MLS), 1.53mm, 2 Holes 30-029664-00 AD5670 (MLS), 1.61mm, 3 Holes 30-029665-00	CD5650▲ 21-29671-20/0	ED5650 [8] (22-29671-00/0)
CORDOBA 1.4L TDI Diesel		05/05 →		28				
BNM	1422	3	79.50	Direct Injection, SOHC	51/70	AD5650 (MLS), 1.45mm, 1 Hole 30-029663-00 AD5660 (MLS), 1.53mm, 2 Holes 30-029664-00 AD5670 (MLS), 1.61mm, 3 Holes 30-029665-00		ED5650 [8] (22-29671-00/0)
BMS/BNV	1422	3	79.50	Direct Injection, SOHC	59/80			
Cordoba 1.6L		06/99 → 10/02		29				
Cordoba 1.6L Vario		06/99 →						
ALM	1598	4	76.50	Injection, SOHC	55/75	BZ180 (MLS), 0.50mm 30-027910-10	DZ181 21-27910-21/0	EB961 [8] 22-28897-03/0

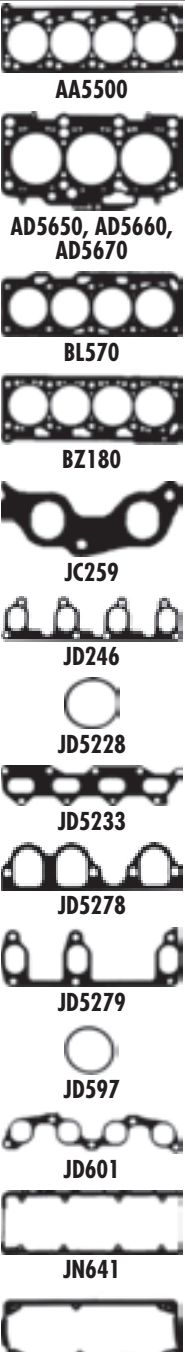







							
<p>HBS043Ⓞ (22-39001B) M11x1.50x95mm (x10) ABD HBS075Ⓞ (22-39011B) M11x1.50x110mm (x10) AEX, AKV, ANX, APQ</p>	<p>JD246■ (31-026474-20) ABD JD597■ ■ 50-350355-00 AEX/AKV/ANX/APQ JC259■ (x2) 31-026229-10 →Eng.ABD 558 154 JD601■ 31-028644-00 Eng.ABD 558 155→ AEX/AKV/ANX/APQ</p>	<p>JN641 50-025265-10 →Eng.ABD 558 154 JP074 50-027907-00 Eng.ABD 558 155→ AEX, AKV, ANX, APQ HM5062■ 24-27907-00/0 AEX, AKV, ANX, APQ</p>	<p>HR397 [57] 34-000410-00 AEX/AKV/ANX/ APQ</p>	<p>HR816■ 24-30653-85/0</p>	<p>■ NA5001 32x47x10mm, FPM (50-303185-50) ■ NA5001■ 32x47x10mm, FPM (50-303185-50) →Eng.AEX 908 121 →Eng.AKV 095 009 ABD ■ NA5133■ 85x105x11mm, FPM (24-30727-87/0) →Eng.AEX 908 121 →Eng.AKV 095 009 ABD ■ NA5185■ 32x42x6mm, FPM (50-319489-00) Eng.AEX 908 122→ Eng.AKV 095 010→ ANX, APQ ■ LK5006■ [3] 85x131x16mm, PTFE (50-319448-00) Eng.AEX 908 122→ Eng.AKV 095 010→ ANX, APQ</p>	<p>HL5020 [245]■ KA5025 [13]</p>	<p>AA5500 AD5650, AD5660, AD5670 BL570 BZ180 JC259 JD246 JD5228 JD5233 JD5278 JD5279 JD597 JD601 JN641 JP074</p>
<p>HBS360Ⓞ (22-39030B) M11x1.50x142mm (x10)</p>	<p>JD5228■ (x4) (50-029071-00) JD5233■ (31-028590-00)</p>		<p>HR397 [57] 34-000410-00</p>	<p>HR791■ 24-30614-76/0</p>	<p>■ NA5001 32x47x10mm, FPM (50-303185-50) ■ NA5001■ 32x47x10mm, FPM (50-303185-50) ■ NA5133■ 85x105x11mm, FPM (24-30727-87/0) →Eng.AFH 030 000 ■ LK5006■ [3] 85x131x16mm, PTFE (50-319448-00) Eng.AFH 030 001→</p>	<p>HL5020 [245]■</p>	<p>JD5278 JD5279 JD597 JD601</p>
<p>HBS264Ⓞ (22-33026B) M12x1.75x166mm (x8)</p>	<p>JD5278■ (31-029671-00) JD5279■ (31-029710-00)</p>	<p>JM7032 50-030224-00</p>	<p>HR397 [57] 34-000410-00</p>	<p>HR5068■ (24-30653-84/0)</p>	<p>■ NA5124 32x47x10mm, PTFE (50-319433-00) ■ NA5106■ 35x48x10mm, PTFE (50-319430-00) ■ LK5003■ [3] 85x131x15.7mm, PTFE (50-319434-00)</p>	<p>HL5034 [245]■</p>	<p>JN641</p>
<p>HBS264Ⓞ (22-33026B) M12x1.75x166mm (x8)</p>	<p>JD5278■ (31-029671-00) JD5279■ (31-029710-00) BNM / BNV</p>	<p>JM7032 50-030224-00 BNM / BNV</p>	<p>HR397 [57] 34-000410-00</p>	<p>HR5068■ (24-30653-84/0)</p>	<p>■ NA5124 32x47x10mm, PTFE (50-319433-00) ■ NA5106■ 35x48x10mm, PTFE (50-319430-00) ■ LK5003■ [3] 85x131x15.7mm, PTFE (50-319434-00)</p>		<p>JP074</p>
<p>HBS043Ⓞ (22-39001B) M11x1.50x95mm (x10)</p>	<p>JD597■ ■ 50-350355-00 JD601■ 31-028644-00</p>	<p>JP074 50-027907-00 HM5062■ 24-27907-00/0</p>	<p>HR397 [57] 34-000410-00</p>	<p>HR816■ 24-30653-85/0</p>	<p>■ NA5001 32x47x10mm, FPM (50-303185-50) ■ NA5001■ 32x47x10mm, FPM (50-303185-50) →Eng.ALM 000 706 ■ LK5006■ [3] 85x131x16mm, PTFE (50-319448-00) ■ NA5185■ 32x42x6mm, FPM (50-319489-00) Eng.ALM 000 707→</p>	<p>HL5020 [245]■</p>	

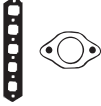

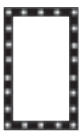
KW/PS

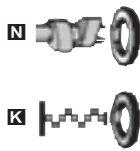

Cordoba 1.6L		06/99 → 10/02		30		AC5220 (MLS)		CC5221		EC080 [8]	
Cordoba 1.6L Vario		06/99 →				30-029462-00		21-29462-21/0		(22-28897-01/0)	
APF	1595	4	81.00	MPI, SOHC	74/100	APF/AUR		APF/AUR		AEH/AKL	
AEH/AKL/AUR	1595	4	81.00	Injection, SOHC	74/101	AY980 (MLS)		CY980		EC5220 [8]	
						30-028925-00		21-28925-20/0		(22-29462-00/0)	
						AEH/AKL		AEH/AKL		APF/AUR	
Cordoba 1.6L 16V		11/06 →		31		AG8850 (MLS)					
BTS	1598	4	76.50	Injection, DOHC	77/105	(30-030218-00)					
Cordoba 1.6L i		05/94 → 06/99		32		BM360 (Fibre)		DM368		EG873	
Cordoba 1.6L i Vario		05/97 → 06/99				30-026807-30		21-26807-20/0			
TF	1595	4	81.00	Monomotronic, SOHC	53/55/ 72/75						
Cordoba 1.6L i		02/93 → 06/99		33		BY620 (Fibre)		DY620		EB961 [8]	
ABU/AEE/ALM						30-027905-00		21-27905-20/0		22-28897-03/0	
	1598	4	76.50	Injection, SOHC	55/75	ABU		ABU		AEE/ALM	
						BZ180 (MLS), 0.50mm		DZ181		EV460	
						30-027910-10		21-27910-21/0		22-26516-01/0	
						AEE/ALM		AEE/ALM		ABU	
Cordoba 1.6L i		07/96 → 06/99		34		AY940 (MLS)		CY941			
Cordoba 1.6L i Vario		09/96 → 06/99				30-028383-00		21-28383-21/0			
AFT	1595	4	81.00	Injection, SOHC	74/101						











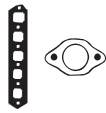

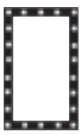

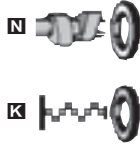











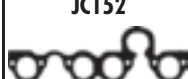















































									
HBS246 ® (22-33024B) M10x1.50x120mm (x10)	JD5340 ■ (x4) (50-029939-00) JD5293 ■ (31-029816-00) APF/AUR JD600 ■ 31-028454-00 AEH/AKL	JP024 50-027505-00	HR397 [57] 34-000410-00 JH5117 (50-030046-00) AEH/AKL/APF	HR816 ■ 24-30653-85/0	NA5124 32x47x10mm, PTFE (50-319433-00) NA5106 ■ 35x48x10mm, PTFE (50-319430-00) LK5008 ■ [3] 85x131x15.7mm, PTFE (50-319472-00)	HL5034 [245] ■		AC5220 AY940 AY980 BM360 BY620 BZ180 JC152 JC478 JD281 JD487 JD488 JD5228 JD5235 JD5293 JD597 JD599 JD600 JD601	JE154 PA459 HL457 JN641 JP024 JP074 JJ140 JJ183
HBS249 ® (22-33025B) M9x1.25x138mm (x10)	JD5228 ■ (x3) (50-029071-00) JD5814 ■ 31-030234-00	HR397 [57] 34-000410-00	HR397 [57] 34-000410-00	HR791 ■ 24-30614-76/0	NA5106 ■ 35x48x10mm, PTFE (50-319430-00)			BM360 BY620 BZ180 JC152 JC478 JD281 JD487 JD488 JD5228 JD5235 JD5293 JD597 JD599 JD600 JD601	JE154 PA459 HL457 JN641 JP024 JP074 JJ140 JJ183
HBS043 ® (22-39001B) M11x1.50x95mm (x10)	JC478 ■ 31-026397-00 →Eng.1F 188 126 PA459 ■ 50-024870-00 (NBR) →Eng.1F 188 126 JD5235 ■ (31-028554-00) Eng.1F 188 127 → JC152 ■ (x4) 31-026555-00	HL457 ■ [79] 24-25753-01/0 (Cork) HM5053 ■ [80] 24-28543-00/0 (ACM)	JJ140 (31-026554-10)	HR569 ■ 24-30667-00/0	NA5001 32x47x10mm, FPM (50-303185-50) NA5001 ■ 32x47x10mm, FPM (50-303185-50) NA5133 ■ 85x105x11mm, FPM (24-30727-87/0)	HL5020 [245] ■ KA5020 [13]		BZ180 JC152 JC478 JD281 JD487 JD488 JD5228 JD5235 JD5293 JD597 JD599 JD600 JD601	JE154 PA459 HL457 JN641 JP024 JP074 JJ140 JJ183
HBS075 ® (22-39011B) M11x1.50x110mm (x10)	JD487 ■ (31-027908-00) ABU JD597 ■ ■ 50-350355-00 AEE/ALM JC152 ■ (x4) 31-026555-00 AEE/ALM JD488 ■ 31-027909-00 ABU JD601 ■ 31-028644-00 AEE/ALM	JN641 50-025265-10 ABU JP074 50-027907-00 AEE/ALM HM5062 ■ 24-27907-00/0 AEE/ALM	HR397 [57] 34-000410-00 AEE/ALM JJ183 (31-026516-10) ABU	HR569 ■ 24-30667-00/0 ABU HR816 ■ 24-30653-85/0 AEE/ALM	NA5001 32x47x10mm, FPM (50-303185-50) NA5001 ■ 32x47x10mm, FPM (50-303185-50) →Eng.AEE 562 757 →Eng.ALM 000 706 ABU NA5133 ■ 85x105x11mm, FPM (24-30727-87/0) →Eng.AEE 562 757 →Eng.ALM 000 706 ABU NA5185 ■ 32x42x6mm, FPM (50-319489-00) Eng.AEE 562 758 → Eng.ALM 000 707 → LK5006 ■ [3] 85x131x16mm, PTFE (50-319448-00) Eng.AEE 562 758 → Eng.ALM 000 707 →	HL5020 [245] ■		BZ180 JC152 JC478 JD281 JD487 JD488 JD5228 JD5235 JD5293 JD597 JD599 JD600 JD601	JE154 PA459 HL457 JN641 JP024 JP074 JJ140 JJ183
HBS043 ® (22-39001B) M11x1.50x95mm (x10)	JD281 ■ (31-027904-00) JD599 ■ (31-027926-00) JD600 ■ 31-028454-00 ⊙ JF205 (31-025070-00)	JP024 50-027505-00		HR816 ■ 24-30653-85/0	NA5001 32x47x10mm, FPM (50-303185-50) NA5001 ■ 32x47x10mm, FPM (50-303185-50) NA5133 ■ 85x105x11mm, FPM (24-30727-87/0)	HL5020 [245] ■		BZ180 JC152 JC478 JD281 JD487 JD488 JD5228 JD5235 JD5293 JD597 JD599 JD600 JD601	JE154 PA459 HL457 JN641 JP024 JP074 JJ140 JJ183



KW/PS

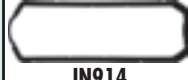

Cordoba 1.8L i					02/93 → 06/99	35	BM360 (Fibre)	DM366
ABS	1781	4	81.00	Injection, SOHC	66/90	30-026807-30	21-26807-26/0	
ADZ	1781	4	81.00	Motronic, SOHC	66/90	→Eng.ADZ 011 565	ABS	
						ABS	DM367	
						BZ910 (MLS)	21-26807-30/0	
						30-027935-00	→Eng.ADZ 011 565	
						Eng.ADZ 011 566 →	DZ910	
							21-27935-20/0	
							Eng.ADZ 011 566 →	
Cordoba 1.8L i 16V					10/93 → 08/96	36	BM360 (Fibre)	DM365
ADL	1781	4	81.00	Injection, DOHC	95/129	30-026807-30	21-26807-21/0	
							ET811	
							(22-26554-40/0)	
Cordoba 1.8L T 20V Cupra					07/00 → 10/02	37	AY970 (MLS)	CY971
AQX	1781	4	81.00	MPI, DOHC	115/156	30-028495-00	21-28495-21/0	
							EY841	
							22-28897-02/0	
Cordoba 1.9L D Diesel					02/93 → 08/96	38	BV850 (MLS), 1.53mm, 1 Hole	DV850▲
Cordoba 1.9L TD Diesel					02/93 → 08/96		30-028545-00	21-26557-20/0
1Y	1896	4	79.50	SOHC	47/64	BV860 (MLS), 1.57mm, 2 Holes	EC030 [8]	
AAZ	1896	4	79.50		55/75	30-028546-00		22-26384-04/0
						BV870 (MLS), 1.61mm, 3 Holes		
						30-028547-00		
Cordoba 1.9L SDI Diesel					06/99 → 10/02	39	BZ040 (MLS), 1.47mm, 1 Hole	DZ010▲☒
Cordoba 1.9L SDI Vario Diesel					06/99 →		30-028915-10	21-26556-20/0
AGP/AQM	1896	4	79.50	Direct Injection, SOHC	50/68	BZ050 (MLS), 1.57mm, 2 Holes	EC060 [8]	
						30-028916-10		
						BZ060 (MLS), 1.67mm, 3 Holes		
						30-028917-10		
Cordoba 1.9L SDI Diesel					09/02 →	40	BZ040 (MLS), 1.47mm, 1 Hole	CC5231▲
ASY	1896	4	79.50	Direct Injection, SOHC	47/64		30-028915-10	21-29463-20/0
						BZ050 (MLS), 1.57mm, 2 Holes	EB5370 [8]	
						30-028916-10		
						BZ060 (MLS), 1.67mm, 3 Holes		
						30-028917-10		
Cordoba 1.9L SDI Diesel					08/96 → 06/99	41	BX800 (MLS), 1.45mm, 1 Hole	DX800▲
Cordoba 1.9L SDI Vario Diesel					09/96 → 06/99		30-028686-00	21-27921-20/0
AEY	1896	4	79.50	SOHC	47/64	BX810 (MLS), 1.53mm, 2 Holes	→Eng.AEY 002 000	
						30-028687-00	DX801▲	
						BX820 (MLS), 1.61mm, 3 Holes	21-27921-21/0	
						30-028688-00	Eng.AEY 002 001 →	







								
HBS043 Ⓞ (22-39001B) M11x1.50x95mm (x10)	JC478 ■ 31-026397-00 →Eng.ADZ 011 565 ABS PA459 ■ 50-024870-00 (NBR) →Eng.ADZ 011 565 ABS JD5235 ■ (31-028554-00) Eng.ADZ 011 566 → JC152 ■ (x4) 31-026555-00 ABS JD606 ■ (31-028918-00) ADZ	JP024 50-027505-00 ADZ HL457 ■ [79] 24-25753-01/0 (Cork) ABS HM5053 ■ [80] 24-28543-00/0 (ACM) ABS	JJ140 (31-026554-10) ABS	HR569 ■ 24-30667-00/0 →Eng.ADZ 011 565 ABS HR816 ■ 24-30653-85/0 Eng.ADZ 011 566 →	NA5001 32x47x10mm, FPM (50-303185-50) NA5001 ■ 32x47x10mm, FPM (50-303185-50) NA5133 ■ 85x105x11mm, FPM (24-30727-87/0)	HL5020 [245]■	 AY970  JP024  BM360  JH5023  BV850, BV860, BV870  JJ140  BX800, BX810, BX820  BZ040, BZ050, BZ060  BZ910  JC152  JC478  JD170  JD281  JD282  JD5235  JD604  JD605  JD606  PA459  HL457  JN914  JP003	
HBS028 Ⓞ (22-39004B) M11x1.50x147mm (x10)	JD281 ■ (31-027904-00) JD282 ■ (x4) (31-026880-00)	HL606 ■ 24-26237-01/0	JJ140 (31-026554-10)	HR816 ■ (x2) 24-30653-85/0	NA5001 32x47x10mm, FPM (50-303185-50) NA5001 ■ 32x47x10mm, FPM (50-303185-50) NA5133 ■ 85x105x11mm, FPM (24-30727-87/0)	HL5020 [245]■	 JC478  JD170  JD281  JD282  JD5235  JD604  JD605  JD606  PA459  HL457  JN914  JP003	
HBS268 Ⓞ (22-33031B) M10x1.50x120mm (x10)	JD604 ■ (31-028824-00) JD605 ■ 31-028826-00	HL732 ■ 24-28815-00/0	HR397 [57] 34-000410-00	HR822 ■	NA5124 32x47x10mm, PTFE (50-319433-00) NA5106 ■ 35x48x10mm, PTFE (50-319430-00) LK5003 ■ [3] 85x131x15.7mm, PTFE (50-319434-00)	HL5034 [245]■	 JD170  JD281  JD282  JD5235  JD604  JD605  JD606  PA459  HL457  JN914  JP003	
HBS018 Ⓞ (22-39024B) M12x1.75x115mm (x10)	JD170 ■ 31-026556-10 JC152 ■ (x4) 31-026555-00	JN914 50-026557-10 HM5058 ■ 24-26557-00/0	JH5023 (31-029043-00)	HR569 ■ 24-30667-00/0	NA5001 32x47x10mm, FPM (50-303185-50) NA5001 ■ 32x47x10mm, FPM (50-303185-50) NA5133 ■ 85x105x11mm, FPM (24-30727-87/0)	HL5020 [245]■ NA5278 [54]	 JD282  JD5235  JD604  JD605  JD606  PA459  HL457  JN914  JP003	
HBS018 Ⓞ (22-39024B) M12x1.75x115mm (x10)	JD170 ■ 31-026556-10 JC152 ■ (x4) 31-026555-00 Ⓞ JE5076 (31-028373-00)		HR397 [57] 34-000410-00	HR816 ■ 24-30653-85/0	NA5001 32x47x10mm, FPM (50-303185-50) NA5106 ■ 35x48x10mm, PTFE (50-319430-00) LK5003 ■ [3] 85x131x15.7mm, PTFE (50-319434-00)	NA5278 [54]	 JD606  PA459  HL457  JN914  JP003	
HBS018 Ⓞ (22-39024B) M12x1.75x115mm (x10)	JD170 ■ 31-026556-10 JC152 ■ (x4) 31-026555-00 Ⓞ JE5076 (31-028373-00)	JM5203 50-029934-00	HR397 [57] 34-000410-00	HR816 ■ 24-30653-85/0	NA5124 32x47x10mm, PTFE (50-319433-00) NA5106 ■ 35x48x10mm, PTFE (50-319430-00) LK5003 ■ [3] 85x131x15.7mm, PTFE (50-319434-00)	HL5034 [245]■	 JD606  PA459  HL457  JN914  JP003	
HBS018 Ⓞ (22-39024B) M12x1.75x115mm (x10)	JD170 ■ 31-026556-10 JC152 ■ (x4) 31-026555-00 Ⓞ JE5076 (31-028373-00)	JP003 50-027921-00	JJ609 (50-027500-00) (ACM)	HR569 ■ 24-30667-00/0 →Eng.AEY 002 000 HR816 ■ 24-30653-85/0 Eng.AEY 002 001 →	NA5001 32x47x10mm, FPM (50-303185-50) NA5001 ■ 32x47x10mm, FPM (50-303185-50) NA5133 ■ 85x105x11mm, FPM (24-30727-87/0)	HL5020 [245]■	 JD606  PA459  HL457  JN914  JP003	

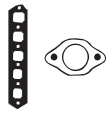

KW/PS

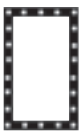

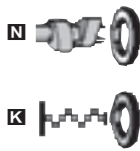
Cordoba 1.9L TDI Diesel		06/99 → 10/02		42		BZ040 (MLS), 1.47mm, 1 Hole 30-028915-10		DZ010▲ 21-26556-20/0		ECO60 [8] 22-28897-00/0	
Cordoba 1.9L TDI Vario Diesel		06/99 →				BZ050 (MLS), 1.57mm, 2 Holes 30-028916-10					
AGR/ALH	1896	4	79.50	Direct Injection, SOHC	66/90	BZ060 (MLS), 1.67mm, 3 Holes 30-028917-10					
ASK/ASV	1896	4	79.50	Direct Injection, SOHC	81/110						
Cordoba 1.9L TDI Diesel		10/02 →		43		AF5381 (MLS), 1.49mm, 1 Hole 30-030098-10		CC5230▲ 21-29463-21/0		EB5370 [8] 22-29314-00/0	
ASZ	1896	4	79.50	Direct Injection, SOHC	96/130	AF5391 (MLS), 1.57mm, 2 Holes 30-030099-10 <td colspan="2"></td> <td colspan="2">BLT</td>				BLT	
BLT	1896	4	79.50	Direct Injection, SOHC	96/131	AF5401 (MLS), 1.65mm, 3 Holes 30-030100-10 <td colspan="2"></td> <td colspan="2">ECO60 [8] 22-28897-00/0</td>				ECO60 [8] 22-28897-00/0	
										ASZ	
Cordoba 1.9L TDI Diesel		09/02 →		44		AF5381 (MLS), 1.49mm, 1 Hole 30-030098-10		CC5230▲ 21-29463-21/0		ECO60 [8] 22-28897-00/0	
ATD/AXR	1896	4	79.50	Direct Injection, SOHC	74/100	AF5391 (MLS), 1.57mm, 2 Holes 30-030099-10 <td colspan="2">ATD/AXR</td> <td colspan="2">ATD/AXR</td>		ATD/AXR		ATD/AXR	
BMT	1896	4	79.50	SOHC	74/101	AF5401 (MLS), 1.65mm, 3 Holes 30-030100-10 <td colspan="2"></td> <td colspan="2"></td>					
Cordoba 1.9L TDI Diesel		08/96 → 06/99		45		BX800 (MLS), 1.45mm, 1 Hole 30-028686-00		DX800▲ 21-27921-20/0		ECO30 [8] 22-26384-04/0	
Cordoba 1.9L TDI Vario Diesel		08/96 → 06/99				BX810 (MLS), 1.53mm, 2 Holes 30-028687-00					
IZ	1896	4	79.50	SOHC	66/89	BX820 (MLS), 1.61mm, 3 Holes 30-028688-00 <td colspan="2"></td> <td colspan="2"></td>					
AHU	1896	4	79.50		66/90						
Cordoba 1.9L TDI Diesel		03/97 → 06/99		46		BX800 (MLS), 1.45mm, 1 Hole 30-028686-00		DX800▲ 21-27921-20/0		ECO30 [8] 22-26384-04/0	
Cordoba 1.9L TDI Vario Diesel		07/97 → 06/99				BX810 (MLS), 1.53mm, 2 Holes 30-028687-00		→ Eng.AFN 002 000			
AFN	1896	4	79.50	SOHC	81/110	BX820 (MLS), 1.61mm, 3 Holes 30-028688-00 <td colspan="2">DX801▲ 21-27921-21/0</td> <td colspan="2"></td>		DX801▲ 21-27921-21/0			
								Eng.AFN 002 001 →			
Cordoba 2.0L		09/02 →		47		AB5370 (MLS) 30-029314-00				EB5370 [8] 22-29314-00/0	
AZL/BBX	1984	4	82.50	Injection, SOHC	85/115						
Cordoba 2.0L i		02/93 → 06/99		48		BT810 (Fibre) 30-027257-20		DT816 21-27257-24/0		EB970 22-27500-01/0	
2E	1984	4	82.50	Digifant	85/115	2E		2E		AGG	
AGG	1984	4	82.50	Injection, SOHC	85/115	BY750 (MLS) 30-027930-00		DY753 21-27930-23/0		ES471 2E	
						AGG		AGG			

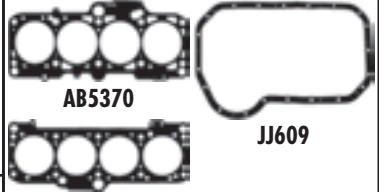









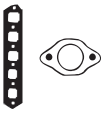

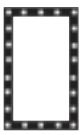

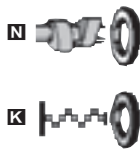













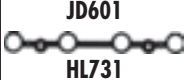















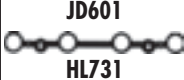





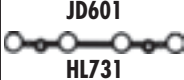

								
HBS018 Ⓢ (22-39024B) M12x1.75x115mm (x10)	JD170 ■ 31-026556-10 JC152 ■ (x4) 31-026555-00		HR397 [57] 34-000410-00	HR816 ■ 24-30653-85/0	■ NA5001 32x47x10mm, FPM (50-303185-50) ■ NB716 ■ 35x48x10mm, FPM (50-306067-50) ■ LK5003 ■ [3] 85x131x15.7mm, PTFE (50-319434-00)	NA5278 [54]		AB5370 BT810 BX800, BX810, BX820
HBS300 Ⓢ (22-33034B) M12x1.75x166mm (x10)	JD170 ■ 31-026556-10 JD600 ■ 31-028454-00	JM5203 50-029934-00	HR397 [57] 34-000410-00	HR816 ■ 24-30653-85/0	■ NA5124 32x47x10mm, PTFE (50-319433-00) ■ NA5106 ■ 35x48x10mm, PTFE (50-319430-00) ■ LK5003 ■ [3] 85x131x15.7mm, PTFE (50-319434-00)	HL5034 [245]■		BY750 BZ040, BZ050, BZ060
HBS300 Ⓢ (22-33034B) M12x1.75x166mm (x10)	JD170 ■ 31-026556-10 JD600 ■ 31-028454-00 ATD/AXR	JM5203 50-029934-00 ATD/AXR	HR397 [57] 34-000410-00	HR816 ■ 24-30653-85/0	■ NA5124 32x47x10mm, PTFE (50-319433-00) ■ NA5106 ■ 35x48x10mm, PTFE (50-319430-00) ■ LK5003 ■ [3] 85x131x15.7mm, PTFE (50-319434-00)	HL5034 [245]■		JC152 JD170 JD483 JD5291 JD5293
HBS018 Ⓢ (22-39024B) M12x1.75x115mm (x10)	JD170 ■ 31-026556-10 JC152 ■ (x4) 31-026555-00	JP003 50-027921-00	JJ609 (50-027500-00) (ACM)	HR569 ■ 24-30667-00/0	■ NA5001 32x47x10mm, FPM (50-303185-50) ■ NA5001 ■ 32x47x10mm, FPM (50-303185-50) ■ NA5133 ■ 85x105x11mm, FPM (24-30727-87/0) →Eng.AHU 390 000 1Z ■ LK5006 ■ [3] 85x131x16mm, PTFE (50-319448-00) Eng.AHU 390 001→	HL5020 [245]■ NA5278 [54]		JD600 LA5204 JM5103 JN964 JP003 JP024 JJ140
HBS018 Ⓢ (22-39024B) M12x1.75x115mm (x10)	JD170 ■ 31-026556-10 JC152 ■ (x4) 31-026555-00	JP003 50-027921-00	JJ609 (50-027500-00) (ACM)	HR569 ■ 24-30667-00/0 →Eng.AFN 002 000 HR816 ■ 24-30653-85/0 Eng.AFN 002 001→	■ NA5001 32x47x10mm, FPM (50-303185-50) ■ NA5001 ■ 32x47x10mm, FPM (50-303185-50) ■ NA5133 ■ 85x105x11mm, FPM (24-30727-87/0)	HL5020 [245]■		JN964 JP003 JP024 JJ140
HBS246 Ⓢ (22-33024B) M10x1.50x120mm (x10)	LA5204 ■ (x4) (50-350416-00) BBX JD5291 ■ ■ (31-029814-00) AZL JD5293 ■ (31-029816-00)	JM5103 (50-029547-00)	HR397 [57] 34-000410-00	HR816 ■ 24-30653-85/0	■ NA5124 32x47x10mm, PTFE (50-319433-00) ■ NA5106 ■ 35x48x10mm, PTFE (50-319430-00) ■ LK5003 ■ [3] 85x131x15.7mm, PTFE (50-319434-00)	HL5034 [245]■		JP003 JP024 JJ140
HBS043 Ⓢ (22-39001B) M11x1.50x95mm (x10)	JD483 ■ (31-027352-00) JC152 ■ (x4) 31-026555-00	JN964 50-026423-10 2E JP024 50-027505-00 AGG	JJ140 (31-026554-10) 2E	HR569 ■ 24-30667-00/0 →Eng.2E 265 664 HR816 ■ 24-30653-85/0 Eng.2E 265 665→ AGG	■ NA5001 32x47x10mm, FPM (50-303185-50) ■ NA5001 ■ 32x47x10mm, FPM (50-303185-50) ■ NA5133 ■ 85x105x11mm, FPM (24-30727-87/0) ■ LK5006 ■ [3] 85x131x16mm, PTFE (50-319448-00)	HL5020 [245]■ NA5278 [54]		JJ140



KW/PS



Cordoba 2.0L i 16V				08/96 → 06/99		49	BT810 (Fibre)		DT81B	EB970
ABF	1984	4	82.50	Injection, DOHC		110/150	30-027257-20 →Eng.ABF 031 251	21-27930-20/0 Eng.ABF 031 252 →		22-27500-01/0
							BY750 (MLS) 30-027930-00 Eng.ABF 031 252 →			
Fura 0.9L				03/84 → 12/86		50	BP520 (Fibre), 1.20mm		CG01A	GP011
09 NCA	903	4	65.00			29/39	(30-026522-20)		DP011 [153]	
100 GL.7000	903	4	65.00			29/40	BP030 (Fibre), 1.80mm (30-025210-20)	21-26522-20/0		
								DR610 [154]		
Ibiza 0.9L				08/90 → 05/93		51	BP520 (Fibre), 1.20mm		CG01A	GP011
09 NCA	903	4	65.00			29/39	(30-026522-20)		DP011 [153]	
146 A.000	903	4	65.00			29-32/ 40-43	BP030 (Fibre), 1.80mm (30-025210-20)	21-26522-20/0		
								DR610 [154]		
Ibiza 1.0L				08/99 → 02/02		52	AD5630 (MLS), 0.50mm		CD5630	
ALD/ANV	999	4	67.10	Motronic, SOHC		37/50	30-029660-00		21-29660-00/0	
AUC	999	4	67.10	Injection, SOHC		37/50				
Ibiza 1.0L				03/93 → 09/96		53	BL570 (Fibre), 1.73mm		DL572	EV460
AAU	1043	4	75.00	SPi, SOHC		33/45	30-024813-20	21-24813-25/0 →Ch.80 PW 000 000		22-26516-01/0
								DL573 (21-24813-28/0) Ch.80 PW 000 001 →		
Ibiza 1.0L i				09/96 → 08/99		54	AA5410 (MLS), 0.60mm		CA5410	EB961 [8]
AER	999	4	67.10	Injection, SOHC		37/50	30-029052-10		21-29052-20/0	22-28897-03/0 →Eng.AER 220 083
Ibiza 1.2L				02/02 →		55	AF5990 (MLS)		CF5990	EF5990
Ibiza 1.2L 12V							(30-030120-00)		21-30120-00/0	22-30371-00/0
Ibiza 1.2L Sport Coupe										
AZQ	1198	3	76.50	Injection, DOHC		47/64				
BXV/BZG	1198	3	76.50	Injection, DOHC		51/70				
Ibiza 1.2L				11/84 → 12/93		56	AA3130 (Fibre)		CA3130	EA3130
Ibiza 1.2L i									21-25917-21/0	22-25920-01/0
021 A.1000	1193	4	75.00			44/46/ 52/60/ 63/70				
021 C.1000	1193	4	75.00	L-Jetronic		52/71				











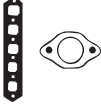

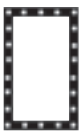

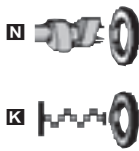













								
HBS028 Ⓢ [22-39004B] M11x1.50x147mm (x10) →Eng.ABF 031 251	JD281 ■ [31-027904-00] JD282 ■ (x4) [31-026880-00] ☉ JF205 [31-025070-00]	HL606 ■ 24-26237-01/0 →Eng.ABF 031 251 HL731 ■ 24-27937-00/0 Eng.ABF 031 252→	JJ609 [50-027500-00] (ACM)	HR816 ■ (x2) 24-30653-85/0	NA5001 32x47x10mm, FPM [50-303185-50] NA5001 ■ 32x47x10mm, FPM [50-303185-50] NA5133 ■ 85x105x11mm, FPM [24-30727-87/0]	HL5020 [245]■		 AA5410  AD5630  BL570  BP520, BP030  BT810  BY750  JC259  JC973  JD246  JD281  JD282  JD5318  JD597  JD601  HL731  JM2052  JM333  JN641  JP074
HBS109 Ⓢ [22-17009B] M9x1.25x60mm (x1) M9x1.25x95mm (x9)	JC973 ■ [31-021833-10]	JM333 [31-021029-00]	HC027 ■ [23-17373-01/0]	HR599 ■ [24-31919-10/0]				 HC027  JJ183  JJ609
HBS109 Ⓢ [22-17009B] M9x1.25x60mm (x1) M9x1.25x95mm (x9)	JC973 ■ [31-021833-10]	JM333 [31-021029-00]	HC027 ■ [23-17373-01/0]	HR599 ■ [24-31919-10/0]				
HBS362 Ⓢ [22-39031B] M9x1.25x162mm (x10)	JD597 ■ ■ 50-350355-00 JD5318 ■ [31-029901-00] ☉ JE5076 [31-028373-00]		HR397 [57] 34-000410-00	HR817 ■ 24-30614-78/0	NA5185 32x42x6mm, FPM [50-319489-00] NA5185 ■ 32x42x6mm, FPM [50-319489-00] LK5011 ■ [3] [78] 85x131x15.94mm, PTFE	KA5025 [13]		 JC259  JC973  JD246  JD281  JD282  JD5318  JD597  JD601  HL731  JM2052  JM333  JN641  JP074
HBS043 Ⓢ [22-39001B] M11x1.50x95mm (x10)	JD246 ■ [31-026474-20] JC259 ■ (x2) 31-026229-10	JN641 50-025265-10	JJ183 [31-026516-10]	HR569 ■ 24-30667-00/0 →Ch.80 PW 000 000 HR816 ■ 24-30653-85/0 Ch.80 PW 000 001→	NA5001 ■ 32x47x10mm, FPM [50-303185-50] NA5133 ■ 85x105x11mm, FPM [24-30727-87/0]			
HBS249 Ⓢ [22-33025B] M9x1.25x138mm (x10)	JD597 ■ ■ 50-350355-00 JD601 ■ 31-028644-00	JP074 50-027907-00 HM5062 ■ 24-27907-00/0	HR397 [57] 34-000410-00	HR816 ■ 24-30653-85/0	NA5001 32x47x10mm, FPM [50-303185-50] NA5001 ■ 32x47x10mm, FPM [50-303185-50] →Eng.AER 220 083 NA5133 ■ 85x105x11mm, FPM [24-30727-87/0] →Eng.AER 220 083 NA5185 ■ 32x42x6mm, FPM [50-319489-00] Eng.AER 220 084→ LK5006 ■ [3] 85x131x16mm, PTFE [50-319448-00] Eng.AER 220 084→	HL5020 [245]■ →Eng.AER 220 083 KA5025 [13]		 JD5318  JD597  JD601  HL731  JM2052  JM333  JN641  JP074
HBS471 Ⓢ [22-39035B] M9x1.25x138mm (x8)	JD5811 ■ (x3) [50-030231-00] JD5816 ■ 31-030236-00	HR397 [57] 34-000410-00	HR397 [57] 34-000410-00	HR280 ■ 24-30614-75/0	NA5106 ■ 35x48x10mm, PTFE [50-319430-00]			 JM333  JN641  JP074
HBS044 Ⓢ [22-42001B] M12x1.75x115mm (x10)		JM2052 [50-025919-00]						



KW/PS



Ibiza 1.3L i		03/93 → 08/99			57	BL570 (Fibre), 1.73mm	DL572	EV460
AAV	1272	4	75.00	Injection, SOHC	40/54	30-024813-20	21-24813-25/0	22-26516-01/0
Ibiza 1.4L		08/99 → 02/02			58	AD5640 (MLS), 0.64mm	CD5640	
AKK	1390	4	76.50	Motronic, SOHC	44/60	30-029662-00	21-29662-20/0	
ANW	1390	4	76.50	MPi, SOHC	44/60			
AUD	1390	4	76.50	Injection, SOHC	44/60			
Ibiza 1.4L 16V		08/99 → 02/02			59	AB5701 (MLS)	CB5700	EB5700 [8]
APE	1390	4	76.50	MPi, DOHC	55/75	30-029313-10	21-29313-20/0	22-29313-00/0
AUA/BBY/BKY	1390	4	76.50	Injection, DOHC	55/75			
AQQ/AUB/BBZ	1390	4	76.50	Injection, DOHC	74/100			
Ibiza 1.4L i		09/93 → 08/99			60	BZ180 (MLS), 0.50mm	DL574	EB961 [8]
ABD	1390	4	75.00	Motronic, SOHC	44/60	30-027910-10	21-24813-27/0	22-28897-03/0
AEX/AKV/APQ	1390	4	76.50	Injection, SOHC	44/60	AEX, AKV, APQ BL570 (Fibre), 1.73mm 30-024813-20 ABD	→Eng.ABD 558 154 DZ181 21-27910-21/0 AEX, AKV, APQ DL573 (21-24813-28/0) Eng.ABD 558 155→	→Eng.AEX 908 121 →Eng.AKV 095 008 EV460 22-26516-01/0 ABD
Ibiza 1.4L i 16V		09/96 → 08/99			61	AA5500 (MLS)	CA5500	EB961 [8]
AFH	1390	4	76.50	Injection, DOHC	74/101	30-029042-00	21-29042-20/0	22-28897-03/0 →Eng.AFH 030 000
Ibiza 1.4L TDI Diesel		05/02 →			62	AD5650 (MLS), 1.45mm, 1 Hole	CD5650	ED5650 [8]
AMF	1422	3	79.50	Direct Injection, SOHC	55/75	30-029663-00 AD5660 (MLS), 1.53mm, 2 Holes 30-029664-00 AD5670 (MLS), 1.61mm, 3 Holes 30-029665-00	21-29671-20/0	(22-29671-00/0)
Ibiza 1.4L TDI Diesel		05/05 →			63	AD5650 (MLS), 1.45mm, 1 Hole		ED5650 [8]
BNM	1422	3	79.50	Direct Injection, SOHC	51/70	30-029663-00		(22-29671-00/0)
BMS/BNV	1422	3	79.50	Direct Injection, SOHC	59/80	AD5660 (MLS), 1.53mm, 2 Holes 30-029664-00 AD5670 (MLS), 1.61mm, 3 Holes 30-029665-00		

								
HBS043 Ⓞ (22-39001B) M11x1.50x95mm (x10)	JD246 ■ (31-026474-20) JC259 ■ (x2) 31-026229-10	JN641 50-025265-10	JJ183 (31-026516-10)	HR569 ■ 24-30667-00/0	NA5001 32x47x10mm, FPM (50-303185-50) NA5001 ■ 32x47x10mm, FPM (50-303185-50) NA5133 ■ 85x105x11mm, FPM (24-30727-87/0)	HL5020 [245]■	 AA5500  AD5640  AD5650, AD5660, AD5670	
HBS362 Ⓞ (22-39001B) M9x1.25x162mm (x10)	JD597 ■ ■ 50-350355-00 JD5318 ■ (31-029901-00)		HR397 [57] 34-000410-00	HR817 ■ 24-30614-78/0	NA5185 32x42x6mm, FPM (50-319489-00) NA5185 ■ 32x42x6mm, FPM (50-319489-00) LK5011 ■ [3] [78] 85x131x15.94mm, PTFE	KA5025 [13]	 BL570  BZ180	
HBS249 Ⓞ (22-33025B) M9x1.25x138mm (x10)	JD5228 ■ (x4) (50-029071-00) JD5298 ■ (31-029825-00)		HR397 [57] 34-000410-00	HR791 ■ 24-30614-76/0	NA5180 27x42x8mm, FPM (50-319484-00) NA5185 ■ 32x42x6mm, FPM (50-319489-00)	KA5025 [13] KK5551 [81]	 JC259  JD246  JD5228  JD5233  JD5278  JD5279  JD5298  JD5318	
HBS043 Ⓞ (22-39001B) M11x1.50x95mm (x10) ABD HBS075 Ⓞ (22-39011B) M11x1.50x110mm (x10) AEX, AKV, APQ	JD246 ■ (31-026474-20) ABD JD597 ■ ■ 50-350355-00 AEX, AKV, APQ JC259 ■ (x2) 31-026229-10 →Eng.ABD 558 154 JD601 ■ 31-028644-00 Eng.ABD 558 155→ AEX/AKV/APQ	JN641 50-025265-10 →Eng.ABD 558 154 JP074 50-027907-00 Eng.ABD 558 155→ AEX, AKV, APQ HM5062 ■ 24-27907-00/0 Eng.ABD 558 155→ AEX, AKV, APQ	HR397 [57] 34-000410-00 AEX/AKV/APQ	HR816 ■ 24-30653-85/0	NA5001 32x47x10mm, FPM (50-303185-50) NA5001 ■ 32x47x10mm, FPM (50-303185-50) →Eng.AEX 908 121 →Eng.AKV 095 009 ABD NA5133 ■ 85x105x11mm, FPM (24-30727-87/0) →Eng.AEX 908 121 →Eng.AKV 095 009 ABD LK5006 ■ [3] 85x131x16mm, PTFE (50-319448-00) Eng.AEX 908 122→ Eng.AKV 095 010→ APQ NA5185 ■ 32x42x6mm, FPM (50-319489-00) Eng.AEX 908 122→ Eng.AKV 095 010→ APQ	HL5020 [245]■ KA5025 [13]	 JD5278  JD5279  JD5298  JD5318  JD597  JD601  JN641  JP074  JJ183	
HBS360 Ⓞ (22-39030B) M11x1.50x142mm (x10)	JD5228 ■ (x4) (50-029071-00) JD5233 ■ (31-028590-00)		HR397 [57] 34-000410-00	HR791 ■ 24-30614-76/0	NA5001 32x47x10mm, FPM (50-303185-50) NA5001 ■ 32x47x10mm, FPM (50-303185-50) NA5133 ■ 85x105x11mm, FPM (24-30727-87/0) →Eng.AFH 030 000 LK5006 ■ [3] 85x131x16mm, PTFE (50-319448-00) Eng.AFH 030 001→	HL5020 [245]■		
HBS264 Ⓞ (22-33026B) M12x1.75x166mm (x8)	JD5278 ■ (31-029671-00) JD5279 ■ (31-029710-00)	JM7032 50-030224-00	HR397 [57] 34-000410-00	HR5068 ■ (24-30653-84/0)	NA5124 32x47x10mm, PTFE (50-319433-00) NA5106 ■ 35x48x10mm, PTFE (50-319430-00) LK5003 ■ [3] 85x131x15.7mm, PTFE (50-319434-00)	HL5034 [245]■		
HBS264 Ⓞ (22-33026B) M12x1.75x166mm (x8)	JD5278 ■ (31-029671-00) JD5279 ■ (31-029710-00) BNM / BNV	JM7032 50-030224-00 BNM / BNV	HR397 [57] 34-000410-00	HR5068 ■ (24-30653-84/0)	NA5124 32x47x10mm, PTFE (50-319433-00) NA5106 ■ 35x48x10mm, PTFE (50-319430-00) LK5003 ■ [3] 85x131x15.7mm, PTFE (50-319434-00)			



KW/PS



Ibiza 1.5L						11/84 → 05/93	64	AA3140 (Fibre)	CA3140	EA3130 (22-25920-01/0)
Ibiza 1.5L i						10/86 → 05/93				
021 A.2000	1461	4	83.00			63/66/ 85/90				
021 C.2000	1461	4	83.00	Injection, SOHC		65-66/ 88-90				
021 D.2000	1461	4	83.00	Injection		65-66/ 89-90				
021 B.2000	1461	4	83.00	Injection		74/100				
Ibiza 1.6L						08/99 → 02/02	65	AC5220 (MLS)	CC5221	EC080 [8] (22-28897-01/0)
APF	1595	4	81.00	MPI, SOHC		74/100	30-029462-00	21-29462-21/0	APF/AUR	AEH/AKL
AEH/AKL/AUR	1595	4	81.00	Injection, SOHC		74/101	APF/AUR AY980 (MLS) 30-028925-00 AEH/AKL	21-28925-20/0	CY980	EC5220 [8] (22-29462-00/0)
Ibiza 1.6L						08/99 → 02/02	66	BZ180 (MLS), 0.50mm	DZ181	EB961 [8] 22-28897-03/0
ALM	1598	4	76.50	Injection, SOHC		55/75	30-027910-10	21-27910-21/0		
Ibiza 1.6L 16V						11/06 →	67	AG8850 (MLS)		
BTS	1598	4	76.50	Injection, DOHC		77/105	(30-030218-00)			
Ibiza 1.6L i						09/94 → 06/99	68	BM360 (Fibre)	DM368	EG873
1F	1595	4	81.00	Monomotronic, SOHC		53/55/ 72/75	30-026807-30	21-26807-20/0		

HBS044 ® (22-42001B) M12x1.75x115mm (x10)		JM2052 (50-025919-00)					 AC5220	 JP024
HBS246 ® (22-33024B) M10x1.50x120mm (x10)	JD5340 ■ (x4) (50-029939-00) JD5293 ■ (31-029816-00) APF/AUR JD600 ■ 31-028454-00 AEH/AKL	JP024 50-027505-00	HR397 [57] 34-000410-00 JH5117 (50-030046-00) AEH/AKL/APF	HR816 ■ 24-30653-85/0	NA5124 32x47x10mm, PTFE (50-319433-00) NA5106 ■ 35x48x10mm, PTFE (50-319430-00) LK5008 ■ [3] 85x131x15.7mm, PTFE (50-319472-00)	HL5034 [245]■	 AY980	 JP074
HBS043 ® (22-39001B) M11x1.50x95mm (x10)	JD597 ■■ 50-350355-00 JD601 ■ 31-028644-00	JP074 50-027907-00 HM5062 ■ 24-27907-00/0	HR397 [57] 34-000410-00	HR816 ■ 24-30653-85/0	NA5001 32x47x10mm, FPM (50-303185-50) NA5001 ■ 32x47x10mm, FPM (50-303185-50) →Eng.AL.M 000 706 LK5006 ■ [3] 85x131x16mm, PTFE (50-319448-00) NA5185 ■ 32x42x6mm, FPM (50-319489-00) Eng.AL.M 000 707→	HL5020 [245]■	 BM360	 JJ140
HBS249 ® (22-33025B) M9x1.25x138mm (x10)	JD5228 ■ (x3) (50-029071-00) JD5814 ■ 31-030234-00	HR397 [57] 34-000410-00	HR397 [57] 34-000410-00	HR791 ■ 24-30614-76/0	NA5106 ■ 35x48x10mm, PTFE (50-319430-00)		 BZ180	 JC152
HBS043 ® (22-39001B) M11x1.50x95mm (x10)	JC478 ■ 31-026397-00 →Eng.1F 188 126 PA459 ■ 50-024870-00 (NBR) →Eng.1F 188 126 JD5235 ■ (31-028554-00) Eng.1F 188 127→ JC152 ■ (x4) 31-026555-00	HL457 ■ [79] 24-25753-01/0 (Cork) HM5053 ■ [80] 24-28543-00/0 (ACM)	JJ140 (31-026554-10)	HR569 ■ 24-30667-00/0	NA5001 32x47x10mm, FPM (50-303185-50) NA5001 ■ 32x47x10mm, FPM (50-303185-50) NA5133 ■ 85x105x11mm, FPM (24-30727-87/0)	HL5020 [245]■ KA5020 [13]	 JC478	 JD5228
							 JD5235	 JD5293
							 JD597	 JD600
							 JD601	 PA459
							 HL457	 JM2052



KW/PS



Model		CC	Cyl	Power (kW/PS)	Injection	Year Range	Code	Part Number	Part Number	Part Number
Ibiza 1.6L i						03/93 → 08/99	69	BY620 (Fibre) 30-027905-00 ABU BZ180 (MLS), 0.50mm 30-027910-10 AEE/ALM	DY620 21-27905-20/0 ABU DZ181 21-27910-21/0 AEE/ALM	EB961 [8] 22-28897-03/0 AEE/ALM EV460 22-26516-01/0 ABU
ABU/AEE/ALM	1598	4	76.50		Injection, SOHC		55/75			
Ibiza 1.6L i						04/96 → 08/99	70	AY940 (MLS) 30-028383-00	CY941 21-28383-21/0	
AFT	1595	4	81.00		Injection, SOHC		74/101			
Ibiza 1.7L SDI Diesel						07/97 → 08/99	71	BX800 (MLS), 1.45mm, 1 Hole 30-028686-00 BX810 (MLS), 1.53mm, 2 Holes 30-028687-00 BX820 (MLS), 1.61mm, 3 Holes 30-028688-00	DX801▲ 21-27921-21/0	EC030 [8] 22-26384-04/0 →Eng.AHB 005 000 →Eng.AKU 013 000
AHB/AKU	1716	4					44/60			
Ibiza 1.8L i						03/93 → 08/99	72	BM360 (Fibre) 30-026807-30 →Eng.ADZ 011 565 ABS BZ910 (MLS) 30-027935-00 Eng.ADZ 011 566 →	DM366 21-26807-26/0 ABS DM367 21-26807-30/0 →Eng.ADZ 011 565 DZ910 21-27935-20/0 Eng.ADZ 011 566 →	
ABS ADZ	1781 1781	4 4	81.00 81.00		Injection, SOHC Motronic, SOHC		66/90 66/90			

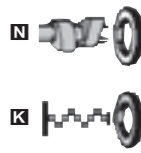
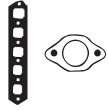

HBS075Ⓞ
(22-39011B)
M11x1.50x110mm (x10)

JD487■
(31-027908-00)
ABU
JD597■ ■
50-350355-00
AEE/ALM
JC152■ (x4)
31-026555-00
AEE/ALM
JD488■
31-027909-00
ABU
JD601■
31-028644-00
AEE/ALM

JN641
50-025265-10
ABU
JP074
50-027907-00
AEE/ALM
HM5062■
24-27907-00/0
AEE/ALM

JJ183
(31-026516-10)
ABU

HR569■
24-30667-00/0
ABU
HR816■
24-30653-85/0
AEE/ALM

■ **NA5001** 32x47x10mm, FPM
(50-303185-50)
■ **NA5001**■ 32x47x10mm, FPM
(50-303185-50)
→Eng.AEE 562 757
→Eng.ALM 000 706
ABU
■ **NA5133**■ 85x105x11mm, FPM
(24-30727-87/0)
→Eng.AEE 562 757
→Eng.ALM 000 706
ABU
■ **LK5006**■ [3] 85x131x16mm, PTFE
(50-319448-00)
Eng.AEE 562 758→
Eng.ALM 000 707→
■ **NA5185**■ 32x42x6mm, FPM
(50-319489-00)
Eng.AEE 562 758→
Eng.ALM 000 707→

HL5020 [245]■

HBS043Ⓞ
(22-39001B)
M11x1.50x95mm (x10)

JD281■
(31-027904-00)
JD599■
(31-027926-00)
JD600■
31-028454-00
Ⓞ **JF205**
(31-025070-00)

JP024
50-027505-00

HR816■
24-30653-85/0

■ **NA5001** 32x47x10mm, FPM
(50-303185-50)
■ **NA5001**■ 32x47x10mm, FPM
(50-303185-50)
■ **NA5133**■ 85x105x11mm, FPM
(24-30727-87/0)

HL5020 [245]■

HBS018Ⓞ
(22-39024B)
M12x1.75x115mm (x10)

JD170■
31-026556-10
JC152■ (x4)
31-026555-00
Ⓞ **JE5076**
(31-028373-00)

JP003
50-027921-00

JJ609
(50-027500-00)
(ACM)

HR816■
24-30653-85/0

■ **NA5001** 32x47x10mm, FPM
(50-303185-50)
■ **NA5001**■ 32x47x10mm, FPM
(50-303185-50)
■ **NA5133**■ 85x105x11mm, FPM
(24-30727-87/0)
→Eng.AHB 005 000
→Eng.AKU 013 000
■ **LK5006**■ [3] 85x131x16mm, PTFE
(50-319448-00)
Eng.AHB 005 001→
Eng.AKU 013 001→

HL5020 [245]■

HBS043Ⓞ
(22-39001B)
M11x1.50x95mm (x10)

JC478■
31-026397-00
→Eng.ADZ 011 565
ABS
PA459■
50-024870-00
(NBR)
→Eng.ADZ 011 565
ABS
JD5235■
(31-028554-00)
Eng.ADZ 011 566→
JC152■ (x4)
31-026555-00
ABS
JD606■
(31-028918-00)
ADZ

JP024
50-027505-00
ADZ
HL457■ [79]
24-25753-01/0
(Cork)
ABS
HM5053■ [80]
24-28543-00/0
(ACM)
ABS

JJ140
(31-026554-10)
ABS

HR569■
24-30667-00/0
→Eng.ADZ 011
565
ABS
HR816■
24-30653-85/0
Eng.ADZ 011
566→

■ **NA5001** 32x47x10mm, FPM
(50-303185-50)
■ **NA5001**■ 32x47x10mm, FPM
(50-303185-50)
■ **NA5133**■ 85x105x11mm, FPM
(24-30727-87/0)

HL5020 [245]■

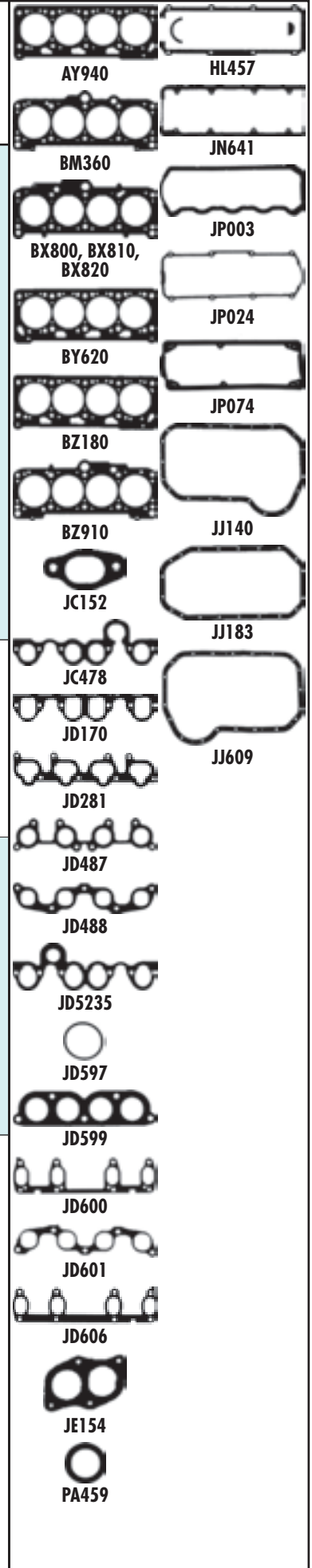









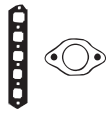

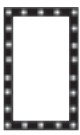

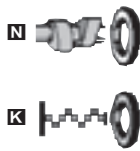













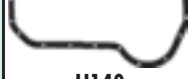











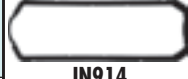

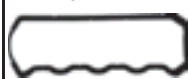

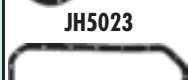

KW/PS

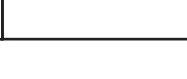

Ibiza 1.8L i 16V		11/93 → 08/96		73	BM360 (Fibre)	DM365	ET811
ADL	1781	4	81.00	Injection, DOHC	95/129 30-026807-30	21-26807-21/0	(22-26554-40/0)
Ibiza 1.8L T 20V Cupra		07/00 → 02/02		74	AY970 (MLS)	CY971	EY841
Ibiza 1.8L T Cupra R		01/04 →			30-028495-00	21-28495-21/0	22-28897-02/0
Ibiza 1.8L T FR		12/03 →					
BJX	1781	4	81.00	Injection, DOHC	110/150		
BKV	1781	4	81.00	Injection	110/150		
AQX	1781	4	81.00	MPi, DOHC	115/156		
AYP	1781	4	81.00	Injection, DOHC	115/156		
BBU	1781	4	81.00	Injection, DOHC	132/180		
Ibiza 1.9L TDI Diesel		03/08 →		75	AF5381 (MLS), 1,49mm, 1 Hole		EF5380
Ibiza 1.9L TDI Sport Coupe Diesel		07/08 →			30-030098-10		22-30369-00/0
BLS	1896	4	79.50	Direct Injection, SOHC	77/105 AF5391 (MLS), 1,57mm, 2 Holes 30-030099-10 AF5401 (MLS), 1,65mm, 3 Holes 30-030100-10		
Ibiza 1.9L D Diesel		04/93 → 08/96		76	BV850 (MLS), 1,53mm, 1 Hole	DV850▲	ECO30 [8]
Ibiza 1.9L TD Diesel		03/93 → 08/96			30-028545-00	21-26557-20/0	22-26384-04/0
1Y	1896	4	79.50		BV860 (MLS), 1,57mm, 2 Holes 30-028546-00		
AAZ	1896	4	79.50	SOHC	BV870 (MLS), 1,61mm, 3 Holes 30-028547-00		
Ibiza 1.9L SDI Diesel		08/99 → 02/02		77	BZ040 (MLS), 1,47mm, 1 Hole	DZ010▲☒	ECO60 [8]
AGP/AQM	1896	4	79.50	Direct Injection, SOHC	50/68 30-028915-10 BZ050 (MLS), 1,57mm, 2 Holes 30-028916-10 BZ060 (MLS), 1,67mm, 3 Holes 30-028917-10	21-26556-20/0	22-28897-00/0
Ibiza 1.9L SDI Diesel		02/02 →		78	BZ040 (MLS), 1,47mm, 1 Hole	CC5231▲	EB5370 [8]
ASY	1896	4	79.50	Direct Injection, SOHC	47/64 30-028915-10 BZ050 (MLS), 1,57mm, 2 Holes 30-028916-10 BZ060 (MLS), 1,67mm, 3 Holes 30-028917-10	21-29463-20/0	22-29314-00/0
Ibiza 1.9L SDI Diesel		08/96 → 08/99		79	BX800 (MLS), 1,45mm, 1 Hole	DX800▲	ECO30 [8]
AEY	1896	4	79.50	SOHC	47/64 30-028686-00 BX810 (MLS), 1,53mm, 2 Holes 30-028687-00 BX820 (MLS), 1,61mm, 3 Holes 30-028688-00	21-27921-20/0 → Eng. AEY 002 000 DX801▲ 21-27921-21/0 Eng. AEY 002 001 →	22-26384-04/0
Ibiza 1.9L TDI Diesel		08/99 → 02/02		80	BZ040 (MLS), 1,47mm, 1 Hole	DZ010▲☒	ECO60 [8]
AGR/ALH	1896	4	79.50	Direct Injection, SOHC	66/90 30-028915-10	21-26556-20/0	22-28897-00/0
ASK/ASV	1896	4	79.50	Direct Injection, SOHC	81/110 BZ050 (MLS), 1,57mm, 2 Holes 30-028916-10 BZ060 (MLS), 1,67mm, 3 Holes 30-028917-10		











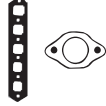

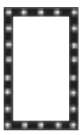

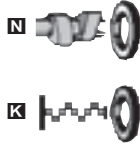

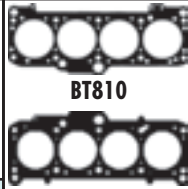













































































































								
HBS028 ® (22-39004B) M11x1.50x147mm (x10)	JD281 ■ (31-027904-00) JD282 ■ (x4) (31-026880-00)	HL606 ■ 24-26237-01/0	JJ140 (31-026554-10)	HR816 ■ (x2) 24-30653-85/0	NA5001 32x47x10mm, FPM (50-303185-50) NA5001 ■ 32x47x10mm, FPM (50-303185-50) NA5133 ■ 85x105x11mm, FPM (24-30727-87/0)	HL5020 [245] ■		 AY970  BM360  BV850, BV860, BV870  BX800, BX810, BX820  BZ040, BZ050, BZ060  JC152  JD170  JD281  JD282  JD604  JD605  JN914  JP003  JH5023  JJ140  JJ609
HBS268 ® (22-33031B) M10x1.50x120mm (x10)	JD604 ■ (31-028824-00) JD605 ■ 31-028826-00	HL732 ■ 24-28815-00/0	HR397 [57] 34-000410-00	HR822 ■	NA5124 32x47x10mm, PTFE (50-319433-00) NA5106 ■ 35x48x10mm, PTFE (50-319430-00) LK5003 ■ [3] 85x131x15.7mm, PTFE (50-319434-00)	HL5034 [245] ■ NA5278 [54]		 NA5124  NA5106  LK5003
HBS300 ® (22-33034B) M12x1.75x166mm (x10)	JD170 ■ 31-026556-10		HR397 [57] 34-000410-00	HR816 ■ 24-30653-85/0	NA5124 32x47x10mm, PTFE (50-319433-00) NA5106 ■ 35x48x10mm, PTFE (50-319430-00) LK5012 ■ [3] [85] 85x132x15.7mm, ACM (50-319535-00)			 NA5124  NA5106  LK5012
HBS018 ® (22-39024B) M12x1.75x115mm (x10)	JD170 ■ 31-026556-10 JC152 ■ (x4) 31-026555-00	JN914 50-026557-10 HM5058 ■ 24-26557-00/0	JH5023 (31-029043-00)	HR569 ■ 24-30667-00/0	NA5001 32x47x10mm, FPM (50-303185-50) NA5001 ■ 32x47x10mm, FPM (50-303185-50) NA5133 ■ 85x105x11mm, FPM (24-30727-87/0)	HL5020 [245] ■ NA5278 [54]		 NA5001  NA5001  NA5133
HBS018 ® (22-39024B) M12x1.75x115mm (x10)	JD170 ■ 31-026556-10 JC152 ■ (x4) 31-026555-00 JE5076 (31-028373-00)		HR397 [57] 34-000410-00	HR816 ■ 24-30653-85/0	NA5001 32x47x10mm, FPM (50-303185-50) NA5106 ■ 35x48x10mm, PTFE (50-319430-00) LK5003 ■ [3] 85x131x15.7mm, PTFE (50-319434-00)	NA5278 [54]		 NA5001  NA5106  LK5003
HBS018 ® (22-39024B) M12x1.75x115mm (x10)	JD170 ■ 31-026556-10 JC152 ■ (x4) 31-026555-00	JM5120 50-029555-00	HR397 [57] 34-000410-00	HR816 ■ 24-30653-85/0	NA5124 32x47x10mm, PTFE (50-319433-00) NA5106 ■ 35x48x10mm, PTFE (50-319430-00) LK5003 ■ [3] 85x131x15.7mm, PTFE (50-319434-00)	HL5034 [245] ■ NA5278 [54]		 NA5124  NA5106  LK5003
HBS018 ® (22-39024B) M12x1.75x115mm (x10)	JD170 ■ 31-026556-10 JC152 ■ (x4) 31-026555-00 JE5076 (31-028373-00)	JP003 50-027921-00	JJ609 (50-027500-00) (ACM)	HR569 ■ 24-30667-00/0 →Eng.AEY 002 000 HR816 ■ 24-30653-85/0 Eng.AEY 002 001 →	NA5001 32x47x10mm, FPM (50-303185-50) NA5001 ■ 32x47x10mm, FPM (50-303185-50) NA5133 ■ 85x105x11mm, FPM (24-30727-87/0)	HL5020 [245] ■ NA5278 [54]		 NA5001  NA5001  NA5133
HBS018 ® (22-39024B) M12x1.75x115mm (x10)	JD170 ■ 31-026556-10 JC152 ■ (x4) 31-026555-00		HR397 [57] 34-000410-00	HR816 ■ 24-30653-85/0	NA5001 32x47x10mm, FPM (50-303185-50) NA5106 ■ 35x48x10mm, PTFE (50-319430-00) NB716 ■ 35x48x10mm, FPM (50-306067-50) LK5003 ■ [3] 85x131x15.7mm, PTFE (50-319434-00)	NA5278 [54]		 NA5001  NA5106  NB716  LK5003



KW/PS



Ibiza 1.9L TDI Diesel				02/02 →		81	AF5381 (MLS), 1,49mm, 1 Hole 30-030098-10 AF5391 (MLS), 1,57mm, 2 Holes 30-030099-10 AF5401 (MLS), 1,65mm, 3 Holes 30-030100-10		CC5230▲ 21-29463-21/0 ATD/AXR	EC060 [8] 22-28897-00/0 ATD/AXR
ATD/AXR	1896	4	79.50	Direct Injection, SOHC	74/100					
BMT	1896	4	79.50	SOHC	74/101					
Ibiza 1.9L TDI Diesel				02/02 →		82	AF5381 (MLS), 1,49mm, 1 Hole 30-030098-10 AF5391 (MLS), 1,57mm, 2 Holes 30-030099-10 AF5401 (MLS), 1,65mm, 3 Holes 30-030100-10		CC5230▲ 21-29463-21/0	EB5370 [8] 22-29314-00/0 BLT EC060 [8] 22-28897-00/0 ASZ
ASZ	1896	4	79.50	Direct Injection, SOHC	96/130					
BLT	1896	4	79.50	Direct Injection, SOHC	96/131					
Ibiza 1.9L TDI Diesel				08/96 →08/99		83	BX800 (MLS), 1.45mm, 1 Hole 30-028686-00 BX810 (MLS), 1.53mm, 2 Holes 30-028687-00 BX820 (MLS), 1.61mm, 3 Holes 30-028688-00		DX800▲ 21-27921-20/0	EC030 [8] 22-26384-04/0
1Z	1896	4	79.50		66/89					
AHU	1896	4	79.50	SOHC	66/90					
Ibiza 1.9L TDI Diesel				02/97 →08/99		84	BX800 (MLS), 1.45mm, 1 Hole 30-028686-00 BX810 (MLS), 1.53mm, 2 Holes 30-028687-00 BX820 (MLS), 1.61mm, 3 Holes 30-028688-00		DX800▲ 21-27921-20/0 →Eng.AFN 002 000 DX801▲ 21-27921-21/0 Eng.AFN 002 001→	EC030 [8] 22-26384-04/0
AFN	1896	4	79.50	SOHC	81/110					
Ibiza 1.9L TDI Cupra R Diesel				01/04 →		85	AF5381 (MLS), 1,49mm, 1 Hole 30-030098-10 AF5391 (MLS), 1,57mm, 2 Holes 30-030099-10 AF5401 (MLS), 1,65mm, 3 Holes 30-030100-10		CC5230▲ 21-29463-21/0	EC060 [8] 22-28897-00/0
ARL	1896	4	79.50	Direct Injection, SOHC	110/150					
Ibiza 1.9L TDI Cupra R Diesel				03/04 →		86	AF5381 (MLS), 1,49mm, 1 Hole 30-030098-10 AF5391 (MLS), 1,57mm, 2 Holes 30-030099-10 AF5401 (MLS), 1,65mm, 3 Holes 30-030100-10		CC5230▲ 21-29463-21/0	EB5370 [8] 22-29314-00/0
BPX	1896	4	79.50	Direct Injection, SOHC	118/160					
BUK	1896	4	79.50		118/160					
Ibiza 2.0L i				03/93 →08/99		87	BT810 (Fibre) 30-027257-20 2E BY750 (MLS) 30-027930-00 AGG		DT816 21-27257-24/0 2E DY753 21-27930-23/0 AGG	EB970 22-27500-01/0 AGG ES471 2E
2E	1984	4	82.50	Digifant	85/115					
AGG	1984	4	82.50	Injection, SOHC	85/115					
Ibiza 2.0L i 16V				08/96 →08/99		88	BT810 (Fibre) 30-027257-20 →Eng.ABF 031 251 BY750 (MLS) 30-027930-00 Eng.ABF 031 252→		DT81B☒ 21-27930-20/0 Eng.ABF 031 252→	
ABF	1984	4	82.50	Injection, DOHC	110/150					

								
HBS300 ® (22-33034B) M12x1.75x166mm (x10)	JD170 ■ 31-026556-10 JD600 ■ 31-028454-00 ATD/AXR	JM5203 50-029934-00 ATD/AXR	HR397 [57] 34-000410-00	HR816 ■ 24-30653-85/0	NA5124 32x47x10mm, PTFE (50-319433-00) NA5106 ■ 35x48x10mm, PTFE (50-319430-00) LK5003 ■ [3] 85x131x15.7mm, PTFE (50-319434-00)	HL5034 [245]■	 BT810  BX800, BX810, BX820  BY750  JC152  JD170  JD281  JD282  JD483  JD600  HL731  JN964  JP003  JP024  JJ140  JJ609	
HBS300 ® (22-33034B) M12x1.75x166mm (x10)	JD170 ■ 31-026556-10 JD600 ■ 31-028454-00	JM5203 50-029934-00	HR397 [57] 34-000410-00	HR816 ■ 24-30653-85/0	NA5124 32x47x10mm, PTFE (50-319433-00) NA5106 ■ 35x48x10mm, PTFE (50-319430-00) LK5003 ■ [3] 85x131x15.7mm, PTFE (50-319434-00)	HL5034 [245]■	 BT810  BX800, BX810, BX820  BY750  JC152  JD170  JD281  JD282  JD483  JD600  HL731  JN964  JP003  JP024  JJ140  JJ609	
HBS018 ® (22-39024B) M12x1.75x115mm (x10)	JD170 ■ 31-026556-10 JC152 ■ (x4) 31-026555-00	JP003 50-027921-00	JJ609 (50-027500-00) (ACM)	HR569 ■ 24-30667-00/0 →Eng.1Z 770 000 AHU HR816 ■ 24-30653-85/0 Eng.1Z 770 001 →	NA5001 32x47x10mm, FPM (50-303185-50) NA5001 ■ 32x47x10mm, FPM (50-303185-50) NA5133 ■ 85x105x11mm, FPM (24-30727-87/0) →Eng.AHU 390 000 1Z LK5006 ■ [3] 85x131x16mm, PTFE (50-319448-00) Eng.AHU 390 001 →	HL5020 [245]■ NA5278 [54]	 BT810  BX800, BX810, BX820  BY750  JC152  JD170  JD281  JD282  JD483  JD600  HL731  JN964  JP003  JP024  JJ140  JJ609	
HBS018 ® (22-39024B) M12x1.75x115mm (x10)	JD170 ■ 31-026556-10 JC152 ■ (x4) 31-026555-00	JP003 50-027921-00	JJ609 (50-027500-00) (ACM)	HR569 ■ 24-30667-00/0 →Eng.AFN 002 000 HR816 ■ 24-30653-85/0 Eng.AFN 002 001 →	NA5001 32x47x10mm, FPM (50-303185-50) NA5001 ■ 32x47x10mm, FPM (50-303185-50) NA5133 ■ 85x105x11mm, FPM (24-30727-87/0)	HL5020 [245]■	 BT810  BX800, BX810, BX820  BY750  JC152  JD170  JD281  JD282  JD483  JD600  HL731  JN964  JP003  JP024  JJ140  JJ609	
HBS300 ® (22-33034B) M12x1.75x166mm (x10)	JD170 ■ 31-026556-10 JD600 ■ 31-028454-00	JM5120 50-029555-00	HR397 [57] 34-000410-00	HR816 ■ 24-30653-85/0	NA5124 32x47x10mm, PTFE (50-319433-00) NA5106 ■ 35x48x10mm, PTFE (50-319430-00) LK5003 ■ [3] 85x131x15.7mm, PTFE (50-319434-00)	HL5034 [245]■	 BT810  BX800, BX810, BX820  BY750  JC152  JD170  JD281  JD282  JD483  JD600  HL731  JN964  JP003  JP024  JJ140  JJ609	
HBS300 ® (22-33034B) M12x1.75x166mm (x10)	JD170 ■ 31-026556-10 JD600 ■ 31-028454-00	JM5120 50-029555-00	HR397 [57] 34-000410-00	HR816 ■ 24-30653-85/0	NA5124 32x47x10mm, PTFE (50-319433-00) NA5106 ■ 35x48x10mm, PTFE (50-319430-00) LK5003 ■ [3] 85x131x15.7mm, PTFE (50-319434-00)	HL5034 [245]■ NA5278 [54]	 BT810  BX800, BX810, BX820  BY750  JC152  JD170  JD281  JD282  JD483  JD600  HL731  JN964  JP003  JP024  JJ140  JJ609	
HBS043 ® (22-39001B) M11x1.50x95mm (x10)	JD483 ■ (31-027352-00) JC152 ■ (x4) 31-026555-00	JN964 50-026423-10 2E JP024 50-027505-00 AGG	JJ140 (31-026554-10) 2E	HR569 ■ 24-30667-00/0 →Eng.2E 265 664 HR816 ■ 24-30653-85/0 Eng.2E 265 665 → AGG	NA5001 32x47x10mm, FPM (50-303185-50) NA5001 ■ 32x47x10mm, FPM (50-303185-50) NA5133 ■ 85x105x11mm, FPM (24-30727-87/0) LK5006 ■ [3] 85x131x16mm, PTFE (50-319448-00)	HL5020 [245]■ NA5278 [54]	 BT810  BX800, BX810, BX820  BY750  JC152  JD170  JD281  JD282  JD483  JD600  HL731  JN964  JP003  JP024  JJ140  JJ609	
HBS028 ® (22-39004B) M11x1.50x147mm (x10) →Eng.ABF 031 251	JD281 ■ (31-027904-00) JD282 ■ (x4) (31-026880-00) JF205 (31-025070-00)	HL606 ■ 24-26237-01/0 →Eng.ABF 031 251 HL731 ■ 24-27937-00/0 Eng.ABF 031 252 →	JJ609 (50-027500-00) (ACM)	HR816 ■ (x2) 24-30653-85/0	NA5001 32x47x10mm, FPM (50-303185-50) NA5001 ■ 32x47x10mm, FPM (50-303185-50) NA5133 ■ 85x105x11mm, FPM (24-30727-87/0)	HL5020 [245]■	 BT810  BX800, BX810, BX820  BY750  JC152  JD170  JD281  JD282  JD483  JD600  HL731  JN964  JP003  JP024  JJ140  JJ609	



KWPS

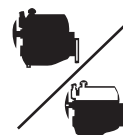

Inca Van 1.4L 16V				04/00 →	89	AB5701 (MLS)	CB5700	EB5700 [8]
AUA	1390	4	76.50	Injection, DOHC	55/75	30-029313-10	21-29313-20/0	22-29313-00/0
Inca Van 1.4L i				11/95 →	90	BZ180 (MLS), 0.50mm	CD5640	EB961 [8]
AEX/AKV/APQ/AUD	1390	4	76.50	Injection, SOHC	44/60	30-027910-10 AEX/AKV/APQ AD5640 (MLS), 0.64mm 30-029662-00 AUD	21-29662-20/0 AUD DZ181 21-27910-21/0 AEX/AKV/APQ	22-28897-03/0 →Eng.AEX 908 121 →Eng.AKV 095 009
Inca Van 1.6L i				11/95 →05/98	91	BZ180 (MLS), 0.50mm	DZ181	EB961 [8]
AEE	1598	4	76.50	Injection, SOHC	55/75	30-027910-10	21-27910-21/0	22-28897-03/0
Inca Van 1.6L i				11/95 →05/98	92	BM360 (Fibre)	DM368	EG873
1F	1595	4	81.00	Monomotronic, SOHC	53/55/ 72/75	30-026807-30	21-26807-20/0	









HBS249 Ⓞ (22-33025B) M9x1.25x138mm (x10)	JD5228 ■ (x4) (50-029071-00) JD5298 ■ (31-029825-00)		HR397 [57] 34-000410-00	HR791 ■ 24-30614-76/0	NA5180 27x42x8mm, FPM (50-319484-00) NA5185 ■ 32x42x6mm, FPM (50-319489-00)	KA5025 [13] KK5551 [81]	AD5640 BM360 BZ180 JC152 JC478 JD5228 JD5235 JD5298 JD5318 JD597 JD601 PA459
HBS075 Ⓞ (22-39011B) M11x1.50x110mm (x10) AEX/AKV/APQ HBS362 Ⓞ (22-39031B) M9x1.25x162mm (x10) AUD	JD597 ■ ■ 50-350355-00 JD5318 ■ (31-029901-00) AUD JD601 ■ 31-028644-00 AEX/AKV/APQ	JP074 50-027907-00 AEX/AKV/APQ HM5062 ■ 24-27907-00/0 AEX/AKV/APQ	HR397 [57] 34-000410-00	HR816 ■ 24-30653-85/0 AEX/AKV/APQ HR817 ■ 24-30614-78/0 AUD	NA5001 32x47x10mm, FPM (50-303185-50) AEX/AKV/APQ NA5185 32x42x6mm, FPM (50-319489-00) AUD NA5001 ■ 32x47x10mm, FPM (50-303185-50) →Eng.AEX 908 121 →Eng.AKV 095 009 NA5133 ■ 85x105x11mm, FPM (24-30727-87/0) →Eng.AEX 908 121 →Eng.AKV 095 009 LK5011 ■ [3] [78] 85x131x15.94mm, PTFE AUD NA5185 ■ 32x42x6mm, FPM (50-319489-00) Eng.AEX 908 122→ Eng.AKV 095 010→ APQ/AUD LK5006 ■ [3] 85x131x16mm, PTFE (50-319448-00) Eng.AEX 908 122→ Eng.AKV 095 010→ APQ	HL5020 [245]■ KA5025 [13]	JC478 JD5228 JD5235 JD5298 JD5318 JD597 JD601 PA459
HBS075 Ⓞ (22-39011B) M11x1.50x110mm (x10)	JD597 ■ ■ 50-350355-00 JD601 ■ 31-028644-00	JP074 50-027907-00 HM5062 ■ 24-27907-00/0	HR397 [57] 34-000410-00	HR816 ■ 24-30653-85/0	NA5001 32x47x10mm, FPM (50-303185-50) NA5001 ■ 32x47x10mm, FPM (50-303185-50) →Eng.AEE 562 757 NA5133 ■ 85x105x11mm, FPM (24-30727-87/0) →Eng.AEE 562 757 LK5006 ■ [3] 85x131x16mm, PTFE (50-319448-00) Eng.AEE 562 578→ NA5185 ■ 32x42x6mm, FPM (50-319489-00) Eng.AEE 562 758→	HL5020 [245]■	HL457 JP074 JJ140
HBS043 Ⓞ (22-39001B) M11x1.50x95mm (x10)	JC478 ■ 31-026397-00 →Eng.1F 188 126 PA459 ■ 50-024870-00 (NBR) →Eng.1F 188 126 JD5235 ■ (31-028554-00) Eng.1F 188 127→ JC152 ■ (x4) 31-026555-00	HL457 ■ [79] 24-25753-01/0 (Cork) HM5053 ■ [80] 24-28543-00/0 (ACM)	JJ140 (31-026554-10)	HR569 ■ 24-30667-00/0	NA5001 32x47x10mm, FPM (50-303185-50) NA5001 ■ 32x47x10mm, FPM (50-303185-50) NA5133 ■ 85x105x11mm, FPM (24-30727-87/0)	HL5020 [245]■ KA5020 [13]	

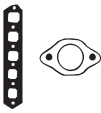

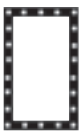
KW/PS

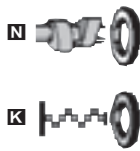

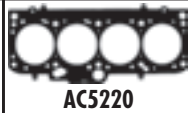
Inca Van 1.7L D Diesel		09/96 →		93		BX800 (MLS), 1.45mm, 1 Hole 30-028686-00 BX810 (MLS), 1.53mm, 2 Holes 30-028687-00 BX820 (MLS), 1.61mm, 3 Holes 30-028688-00	DX801▲ 21-27921-21/0	EC030 [8] 22-26384-04/0
AHB	1716	4	79.50	Direct Injection, SOHC	42/57			
Inca Van 1.9L D Diesel		11/95 →		94		BV850 (MLS), 1.53mm, 1 Hole 30-028545-00 BV860 (MLS), 1.57mm, 2 Holes 30-028546-00 BV870 (MLS), 1.61mm, 3 Holes 30-028547-00	DV850▲ 21-26557-20/0	EC030 [8] 22-26384-04/0
TY	1896	4	79.50		47/64			
Inca Van 1.9L SDI Diesel		11/95 →		95		BX800 (MLS), 1.45mm, 1 Hole 30-028686-00 BX810 (MLS), 1.53mm, 2 Holes 30-028687-00 BX820 (MLS), 1.61mm, 3 Holes 30-028688-00	DX800▲ 21-27921-20/0 →Eng.AEY 002 000 DX801▲ 21-27921-21/0 Eng.AEY 002 001 →	EC030 [8] 22-26384-04/0
AEY	1896	4	79.50	SOHC	47/64			
Inca Van 1.9L TDI Diesel		09/96 →		96		BZ040 (MLS), 1.47mm, 1 Hole 30-028915-10 BZ050 (MLS), 1.57mm, 2 Holes 30-028916-10 BZ060 (MLS), 1.67mm, 3 Holes 30-028917-10	DZ010▲ ☒ 21-26556-20/0	EC060 [8] 22-28897-00/0
ALH	1896	4	79.50	Direct Injection, SOHC	66/90			
AYQ	1896	4	79.50	Direct Injection, SOHC	47/64			
Leon 1.4L 16V		11/99 →		97		AB5701 (MLS) 30-029313-10	CB5700 ☒ 21-29313-20/0	EB5700 [8] 22-29313-00/0
AHW/APE	1390	4	76.50	MPI, DOHC	55/75			
AXP/BCA	1390	4	76.50	Injection, DOHC	55/75			
Leon 1.6L		11/99 →		98		AY980 (MLS) 30-028925-00	CY980 21-28925-20/0	EC080 [8] (22-28897-01/0)
AEH/AKL	1595	4	81.00	Injection, SOHC	74/101			
Leon 1.6L		09/05 →		99		AC5220 (MLS) 30-029462-00	CC5222 21-29462-22/0	EC5220 [8] (22-29462-00/0)
BSE/BSF	1595	4	81.00	Injection, SOHC	75/102			
Leon 1.6L 16 V		09/00 →		100		AC5280 (MLS) 30-029466-00	CC5280 ☒ [41] 21-29466-20/0 AUS CC5281 ☒ 21-29466-21/0 AZD/BCB	
AUS/AZD/BCB	1598	4	76.50	Injection, DOHC	77/105			







									
HBS018 Ⓞ (22-39024B) M12x1.75x115mm (x10)	JD170 ■ 31-026556-10 JC152 ■ (x4) 31-026555-00 Ⓞ JE5076 (31-028373-00)	JP003 50-027921-00	JJ609 (50-027500-00) (ACM)	HR816 ■ 24-30653-85/0	NA5001 32x47x10mm, FPM (50-303185-50) NA5001 ■ 32x47x10mm, FPM (50-303185-50) NA5133 ■ 85x105x11mm, FPM (24-30727-87/0) →Eng.AHB 005 000 LK5006 ■ [3] 85x131x16mm, PTFE (50-319448-00) Eng.AHB 005 001→	HL5020 [245]■	AC5220 AC5280 AY980 BV850, BV860, BV870		
HBS018 Ⓞ (22-39024B) M12x1.75x115mm (x10)	JD170 ■ 31-026556-10 JC152 ■ (x4) 31-026555-00	JN914 50-026557-10 HM5058 ■ 24-26557-00/0	JH5023 (31-029043-00)	HR569 ■ 24-30667-00/0	NA5001 32x47x10mm, FPM (50-303185-50) NA5001 ■ 32x47x10mm, FPM (50-303185-50) NA5133 ■ 85x105x11mm, FPM (24-30727-87/0)	HL5020 [245]■	BX800, BX810, BX820		
HBS018 Ⓞ (22-39024B) M12x1.75x115mm (x10)	JD170 ■ 31-026556-10 JC152 ■ (x4) 31-026555-00 Ⓞ JE5076 (31-028373-00)	JP003 50-027921-00	JJ609 (50-027500-00) (ACM)	HR569 ■ 24-30667-00/0 →Eng.AEY 002 000 HR816 ■ 24-30653-85/0 Eng.AEY 002 001→	NA5001 32x47x10mm, FPM (50-303185-50) NA5001 ■ 32x47x10mm, FPM (50-303185-50) NA5133 ■ 85x105x11mm, FPM (24-30727-87/0)	HL5020 [245]■	BZ040, BZ050, BZ060 JC152 JD170		
HBS018 Ⓞ (22-39024B) M12x1.75x115mm (x10)	JD170 ■ 31-026556-10 JC152 ■ (x4) 31-026555-00		HR397 [57] 34-000410-00	HR816 ■ 24-30653-85/0	NA5001 32x47x10mm, FPM (50-303185-50) NB716 ■ 35x48x10mm, FPM (50-306067-50) LK5003 ■ [3] 85x131x15.7mm, PTFE (50-319434-00)		JD5228 JD5293 JD5298 JD5373		
HBS249 Ⓞ (22-33025B) M9x1.25x138mm (x10)	JD5228 ■ (x4) (50-029071-00) JD5298 ■ (31-029825-00)		HR397 [57] 34-000410-00	HR791 ■ 24-30614-76/0	NA5180 27x42x8mm, FPM (50-319484-00) NA5185 ■ 32x42x6mm, FPM (50-319489-00) LK5011 ■ [3] [78] 85x131x15.94mm, PTFE	KA5025 [13] KK5551 [81]	JD600		
HBS246 Ⓞ (22-33024B) M10x1.50x120mm (x10)	JD5340 ■ (x4) (50-029939-00) JD600 ■ 31-028454-00	JP024 50-027505-00	HR397 [57] 34-000410-00 JH5117 (50-030046-00)	HR816 ■ 24-30653-85/0	NA5124 32x47x10mm, PTFE (50-319433-00) NA5106 ■ 35x48x10mm, PTFE (50-319430-00) LK5008 ■ [3] 85x131x15.7mm, PTFE (50-319472-00)	HL5034 [245]■	JN914 JP003		
HBS246 Ⓞ (22-33024B) M10x1.50x120mm (x10)	JD5340 ■ (x4) (50-029939-00) JD5293 ■ (31-029816-00)	JM5205 50-029938-00 (Rubber)	HR397 [57] 34-000410-00	HR817 ■ 24-30614-78/0	NA5124 32x47x10mm, PTFE (50-319433-00) NA5106 ■ 35x48x10mm, PTFE (50-319430-00) LK5008 ■ [3] 85x131x15.7mm, PTFE (50-319472-00)	HL5034 [245]■	JP024		
HBS316 Ⓞ (22-33036B) M9x1.25x97mm (x10)	JD5228 ■ (x4) (50-029071-00) AZD/BCB JD5373 ■ (31-029966-00) AUS JD5298 ■ (31-029825-00)	HR397 [57] 34-000410-00	HR397 [57] 34-000410-00	HR791 ■ 24-30614-76/0	NA5180 (x2) 27x42x8mm, FPM (50-319484-00) NA5185 ■ 32x42x6mm, FPM (50-319489-00) LK5011 ■ [3] [78] 85x131x15.94mm, PTFE AUS	KK5551 [81]	JH5023		

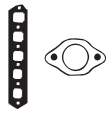

KW/PS

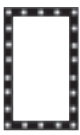

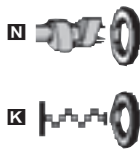
Leon 1.8L 20V		11/99 →		101		AY970 (MLS)		EY841	
AGN/APG	1781	4	81.00	MPI, DOHC	92/125	30-028495-00		22-28897-02/0	AGN
Leon 1.8L 20V T		11/99 →		102		AY970 (MLS)		CY971	
Leon 1.8L 20V T 4						30-028495-00		21-28495-21/0	22-28897-02/0
AUQ	1781	4	81.00	Injection, DOHC	132/180				
APP	1781	4	81.00	MPI, DOHC	132/180				
ARY/AUQ	1781	4	81.00	Injection, DOHC	132/180				
Leon 1.8L T 20V		09/05 →		103		AY970 (MLS)		CY971	
Leon 1.8L T Cupra R						30-028495-00		21-28495-21/0	22-28897-02/0
AUQ	1781	4	81.00	Injection, DOHC	132/180				
AMK	1781	4	81.00	Injection, DOHC	154/209				
BAM	1781	4	81.00	Injection, DOHC	165/225				
Leon 1.9L SDI Diesel		11/99 →		104		BZ040 (MLS), 1.47mm, 1 Hole		DZ010▲☒	
AQM	1896	4	79.50	Direct Injection, SOHC	50/68	30-028915-10		21-26556-20/0	22-28897-00/0
						BZ050 (MLS), 1.57mm, 2 Holes			
						30-028916-10			
						BZ060 (MLS), 1.67mm, 3 Holes			
						30-028917-10			
Leon 1.9L TDI Diesel		11/99 →		105		BZ040 (MLS), 1.47mm, 1 Hole		DZ010▲☒	
AGR/ALH	1896	4	79.50	Direct Injection, SOHC	66/90	30-028915-10		21-26556-20/0	22-28897-00/0
AHF/ASV	1896	4	79.50	Direct Injection, SOHC	81/110				
						BZ050 (MLS), 1.57mm, 2 Holes			
						30-028916-10			
						BZ060 (MLS), 1.67mm, 3 Holes			
						30-028917-10			
Leon 1.9L TDI Diesel		02/01 →		106		AF5381 (MLS), 1.49mm, 1 Hole		CC5231▲	
Leon 1.9L TDI Syncro Diesel						30-030098-10		21-29463-20/0	22-29314-00/0
ARL	1896	4	79.50	Direct Injection, SOHC	110/150				
						AF5391 (MLS), 1.57mm, 2 Holes			
						30-030099-10			
						AF5401 (MLS), 1.65mm, 3 Holes			
						30-030100-10			
Leon 1.9L TDI Diesel		05/03 →		107		AF5381 (MLS), 1.49mm, 1 Hole		CC5230▲	
AXR	1896	4	79.50	Direct Injection, SOHC	74/100	30-030098-10		21-29463-21/0	22-29314-00/0
ASZ	1896	4	79.50	Direct Injection, SOHC	96/130				
						AF5391 (MLS), 1.57mm, 2 Holes			
						30-030099-10			
						AF5401 (MLS), 1.65mm, 3 Holes			
						30-030100-10			
Leon 1.9L TDI Diesel		09/05 →		108		AF5381 (MLS), 1.49mm, 1 Hole		CC5230▲	
BKC/BLS/BXE	1896	4	79.50	Direct Injection, SOHC	77/105	30-030098-10		21-29463-21/0	22-30369-00/0
								BKC/BXE	
						AF5391 (MLS), 1.57mm, 2 Holes			
						30-030099-10			
						AF5401 (MLS), 1.65mm, 3 Holes			
						30-030100-10			
Leon 2.0L TDI Diesel		10/05 →		109		AG9630 (MLS), 1.45mm, 1 Hole		EF5380	
BMM	1968	4	81.00	Direct Injection, SOHC	103/140	30-030349-00		22-30369-00/0	
						AG9640 (MLS), 1.53mm, 2 Holes			
						AG9650 (MLS), 1.61mm, 3 Holes			

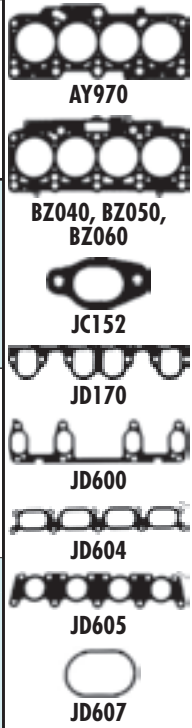









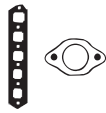

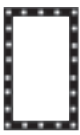

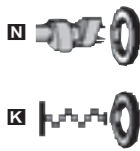



								
HBS268 ® (22-33031B) M10x1.50x120mm (x10)	JD607 ■ 50-028924-00 JD605 ■ 31-028826-00 ☉ JF205 (31-025070-00)	HL732 ■ 24-28815-00/0	HR397 [57] 34-000410-00 JH5117 (50-030046-00)	HR822 ■	NA5124 (x2) 32x47x10mm, PTFE (50-319433-00) NA5106 ■ 35x48x10mm, PTFE (50-319430-00) LK5003 ■ [3] 85x131x15.7mm, PTFE (50-319434-00)	HL5040 [245]■		AY970 BZ040, BZ050, BZ060 JC152 JD170 JD600 JD604 JD605 JD607
HBS268 ® (22-33031B) M10x1.50x120mm (x10)	JD604 ■ (31-028824-00) JD605 ■ 31-028826-00 ☉ JF205 (31-025070-00)	HL732 ■ 24-28815-00/0	HR397 [57] 34-000410-00 JH5117 (50-030046-00) AIQ/APP	HR822 ■	NA5124 (x2) 32x47x10mm, PTFE (50-319433-00) NA5106 ■ 35x48x10mm, PTFE (50-319430-00) LK5003 ■ [3] 85x131x15.7mm, PTFE (50-319434-00)	HL5040 [245]■		
HBS268 ® (22-33031B) M10x1.50x120mm (x10)	JD604 ■ (31-028824-00) JD605 ■ 31-028826-00	HL732 ■ 24-28815-00/0	HR397 [57] 34-000410-00	HR822 ■	NA5001 (x2) 32x47x10mm, FPM (50-303185-50) NA5106 ■ 35x48x10mm, PTFE (50-319430-00) LK5003 ■ [3] 85x131x15.7mm, PTFE (50-319434-00)			
HBS018 ® (22-39024B) M12x1.75x115mm (x10)	JD170 ■ 31-026556-10 JC152 ■ (x4) 31-026555-00		HR397 [57] 34-000410-00	HR816 ■ 24-30653-85/0	NA5001 32x47x10mm, FPM (50-303185-50) NA5106 ■ 35x48x10mm, PTFE (50-319430-00) LK5003 ■ [3] 85x131x15.7mm, PTFE (50-319434-00)	NA5278 [54]		
HBS018 ® (22-39024B) M12x1.75x115mm (x10)	JD170 ■ 31-026556-10 JC152 ■ (x4) 31-026555-00		HR397 [57] 34-000410-00	HR816 ■ 24-30653-85/0	NA5001 32x47x10mm, FPM (50-303185-50) NA5106 ■ 35x48x10mm, PTFE (50-319430-00) NB716 ■ 35x48x10mm, FPM (50-306067-50) LK5003 ■ [3] 85x131x15.7mm, PTFE (50-319434-00)	NA5278 [54]		
HBS018 ® (22-39024B) M12x1.75x115mm (x10)	JD170 ■ 31-026556-10 JC152 ■ (x4) 31-026555-00	JM5203 50-029934-00	HR397 [57] 34-000410-00	HR816 ■ 24-30653-85/0	NA5124 32x47x10mm, PTFE (50-319433-00) NA5106 ■ 35x48x10mm, PTFE (50-319430-00) LK5003 ■ [3] 85x131x15.7mm, PTFE (50-319434-00)	HL5034 [245]■		
HBS300 ® (22-33034B) M12x1.75x166mm (x10)	JD170 ■ 31-026556-10 JD600 ■ 31-028454-00	JM5203 50-029934-00	HR397 [57] 34-000410-00	HR816 ■ 24-30653-85/0	NA5124 32x47x10mm, PTFE (50-319433-00) NA5106 ■ 35x48x10mm, PTFE (50-319430-00) LK5003 ■ [3] 85x131x15.7mm, PTFE (50-319434-00)	HL5034 [245]■		
HBS300 ® (22-33034B) M12x1.75x166mm (x10)	JD170 ■ 31-026556-10 JD600 ■ 31-028454-00 BKC/BXE	JM5203 50-029934-00 BKC/BXE	HR397 [57] 34-000410-00	HR816 ■ 24-30653-85/0	NA5124 32x47x10mm, PTFE (50-319433-00) NA5106 ■ 35x48x10mm, PTFE (50-319430-00) LK5012 ■ [3] [85] 85x132x15.7mm, ACM (50-319535-00)	HL5034 [245]■		
HBS300 ® (22-33034B) M12x1.75x166mm (x10)	JD170 ■ 31-026556-10		HR397 [57] 34-000410-00	HR816 ■ 24-30653-85/0	NA5124 32x47x10mm, PTFE (50-319433-00) NA5106 ■ 35x48x10mm, PTFE (50-319430-00) LK5012 ■ [3] [85] 85x132x15.7mm, ACM (50-319535-00)			



KW/PS

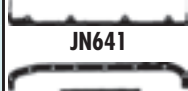

Model		Year Range	Cylinders	Power (kW/PS)	Injection	Code	Part Number	Accessories
Leon 2.0L TDI Diesel		10/05 →		110			AG8970 (MLS), 1.55mm, 1 Hole 30-030249-00	EF5380 22-30369-00/0
Leon 2.0L TDI 16V Diesel		09/05 →					AG8800 (MLS), 1.63mm, 2 Holes (30-030213-00)	
AZV	1968	4	81.00		Direct Injection, DOHC	100/136	AG8960 (MLS), 1.71mm, 3 Holes (30-030248-00)	
BKD	1968	4	81.00		Direct Injection, DOHC	103/140		
Leon 2.0L FSI		09/05 →		111			AG9600 (MLS) 30-030352-00	EG9600 22-30370-00/0
BLR/BLY/BVY/BVZ	1984	4	82.50		Injection, DOHC	110/150		
Leon 2.0L TDI Diesel		02/06 →		112			AG8970 (MLS), 1.55mm, 1 Hole 30-030249-00	EF5380 22-30369-00/0
BMN	1968	4	81.00		Direct Injection, DOHC	125/170	AG8800 (MLS), 1.63mm, 2 Holes (30-030213-00)	
							AG8960 (MLS), 1.71mm, 3 Holes (30-030248-00)	
Leon 2.8L		05/02 →06/04		113			AG5000 (MLS) (30-030123-00)	CG5030 21-30123-30/0
BDE	2792	6	81.00		Injection, DOHC, V6	150/204		EG7800
Leon Cupra		02/01 →		114			AG5000 (MLS) (30-030123-00)	CG5010 21-30123-10/0
AUE	2792	6	81.00		Injection, DOHC, V6	150/204		EG7800
Malaga 1.2L		11/84 →12/93		115			AA3130 (Fibre)	CA3130 (21-25917-21/0)
Malaga 1.2L i		12/89 →12/93						EA3130 (22-25920-01/0)
021 A.1000	1193	4	75.00			44/46/ 52/60/ 63/70		
021 C.1000	1193	4	75.00		L-letronic	52/71		
Malaga 1.5L		05/85 →12/93		116			AA3140 (Fibre)	CA3140 EA3130 (22-25920-01/0)
Malaga 1.5L i		10/86 →12/93						
021 A.2000	1461	4	83.00			63/66/ 85/90		
021 C.2000	1461	4	83.00		Injection, SOHC	65-66/ 88-90		
021 D.2000	1461	4	83.00		Injection	65-66/ 89-90		
021 B.2000	1461	4	83.00		Injection	74/100		
Terra 0.9L		02/87 →12/96		117			BP520 (Fibre), 1.20mm (30-026522-20)	DP011 [153] (21-26522-20/0)
Terra Van 0.9L		01/87 →12/95					BPO30 (Fibre), 1.80mm (30-025210-20)	
09 NCB	903	4			OHV	29/40		
09 NCA	903	4	65.00			29/39		
Terra 1.3L D Diesel		03/90 →12/94		118			BV460 (Fibre), 1.53mm, 1 Notch 30-027103-00	DV460 ▲ 21-25265-21/0
Terra Van 1.3L D Diesel		03/90 →02/92					BV470 (Fibre), 1.57mm, 2 Notches 30-027104-00	EV460 22-26516-01/0
MN	1272	4	75.00			33/44	BV480 (Fibre), 1.61mm, 3 Notches 30-027105-00	
Terra 1.4L D Diesel		10/90 →12/95		119			BV460 (Fibre), 1.53mm, 1 Notch 30-027103-00	DV460 ▲ 21-25265-21/0
Terra Van 1.4L D Diesel		10/90 →02/92					BV470 (Fibre), 1.57mm, 2 Notches 30-027104-00	EV460 22-26516-01/0
1W	1398	4	75.00			35/47	BV480 (Fibre), 1.61mm, 3 Notches 30-027105-00	
Toledo 1.4L 16V		07/99 →05/06		120			AB5701 (MLS) 30-029313-10	CB5700 ☒ 21-29313-20/0
AHW	1390	4	76.50		MPi, DOHC	55/75		EB5700 [8] 22-29313-00/0
AXP	1390	4	76.50		Injection, DOHC	55/75		











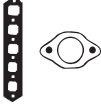

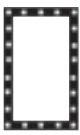

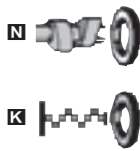









								
HBS364 Ⓢ (22-39032B) M12x1.75x149mm (x10)	JD5805 ■ 50-030225-00 JD5806 ■ 31-030226-00 JD5815 ■ 31-030235-00	JM7031 50-030223-00 (Rubber)	HR397 [57] 34-000410-00	HR791 ■ 24-30614-76/0	■ NA5124 (x2) 32x47x10mm, PTFE (50-319433-00) ■ NA5106 ■ 35x48x10mm, PTFE (50-319430-00) ■ LK5012 ■ [3] [85] 85x132x15.7mm, ACM (50-319535-00)	KK5522 [86]	 AG5000  BP520, BP030  BV460, BV470, BV480  JC259  JC973  JD246  JD5298  JM2052  JM333  JN641  HC027  JJ183	
HBS363 Ⓢ (22-33038B) M10x1.50x122mm (x10)	JD5873 ■ 50-030353-00 (FPM) JD5813 ■ 31-030233-00		HR397 [57] 34-000410-00	HR791 ■ 24-30614-76/0	■ NA5124 32x47x10mm, PTFE (50-319433-00) ■ NA5106 ■ 35x48x10mm, PTFE (50-319430-00) ■ LK5008 ■ [3] 85x131x15.7mm, PTFE (50-319472-00)	HL5034 [245] ■		
HBS364 Ⓢ (22-39032B) M12x1.75x149mm (x10)	JD5805 ■ 50-030225-00 JD5806 ■ 31-030226-00		HR397 [57] 34-000410-00	HR791 ■ 24-30614-76/0	■ NA5124 (x2) 32x47x10mm, PTFE (50-319433-00) ■ NA5106 ■ 35x48x10mm, PTFE (50-319430-00) ■ LK5012 ■ [3] [85] 85x132x15.7mm, ACM (50-319535-00)	HL5034 [245] ■ KK5522 [86]		
	JD5857 ■ 50-030160-00 (Rubber)	JM7045 50-030133-00 (Rubber)	HR397 [57] 34-000410-00	HR5062 ■ 24-30614-73/0	■ NA5106 ■ 35x48x10mm, PTFE (50-319430-00)			
	JD5857 ■ 50-030160-00 (Rubber)		HR397 [57] 34-000410-00	HR5062 ■ 24-30614-73/0	■ NA5106 ■ 35x48x10mm, PTFE (50-319430-00)			
HBS044 Ⓢ (22-42001B) M12x1.75x115mm (x10)		JM2052 (50-025919-00)						
HBS044 Ⓢ (22-42001B) M12x1.75x115mm (x10)		JM2052 (50-025919-00)						
HBS109 Ⓢ (22-17009B) M9x1.25x60mm (x1) M9x1.25x95mm (x9)	JC973 ■ (31-021833-10)	JM333 (31-021029-00)	HC027 ■ (23-17373-01/0)	HR646 ■ 24-30670-60/0	■ NB633 ■ 42x63x7mm, ACM (50-319184-00)			
HBS018 Ⓢ (22-39024B) M12x1.75x115mm (x10)	JD246 ■ (31-026474-20) JC259 ■ (x2) 31-026229-10	JN641 50-025265-10	JJ183 (31-026516-10)	HR569 ■ 24-30667-00/0	■ NA5001 32x47x10mm, FPM (50-303185-50) ■ NA5001 ■ 32x47x10mm, FPM (50-303185-50) ■ NA5133 ■ 85x105x11mm, FPM (24-30727-87/0)	HL5020 [245] ■		
HBS018 Ⓢ (22-39024B) M12x1.75x115mm (x10)	JD246 ■ (31-026474-20) JC259 ■ (x2) 31-026229-10	JN641 50-025265-10	JJ183 (31-026516-10)	HR569 ■ 24-30667-00/0	■ NA5001 32x47x10mm, FPM (50-303185-50) ■ NA5001 ■ 32x47x10mm, FPM (50-303185-50) ■ NA5133 ■ 85x105x11mm, FPM (24-30727-87/0)	HL5020 [245] ■		
HBS249 Ⓢ (22-33025B) M9x1.25x138mm (x10)	JD5288 ■ (x4) (31-029809-00) JD5298 ■ (31-029825-00)	HR397 [57] 34-000410-00	HR397 [57] 34-000410-00	HR791 ■ 24-30614-76/0	■ NA5180 27x42x8mm, FPM (50-319484-00) ■ NA5185 ■ 32x42x6mm, FPM (50-319489-00)	KA5025 [13] KK5551 [81]		



KW/PS

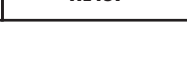

Toledo 1.6L				04/99 → 09/00		121	AY980 (MLS)	CY980	EC080 [8]
AEH/AKL	1595	4	81.00	Injection, SOHC	74/101	30-028925-00	21-28925-20/0	(22-28897-01/0)	
Toledo 1.6L				10/04 →		122	AC5220 (MLS)	CC5222	EC5220 [8]
BGU/BSE/BSF	1595	4	81.00	Injection, SOHC	75/102	30-029462-00	21-29462-22/0	(22-29462-00/0)	
Toledo 1.6L 16V				09/00 → 05/06		123	AC5280 (MLS)	CC5280 [41]	
AUS/AZD/BCB	1598	4	76.50	Injection, DOHC	77/105	30-029466-00	21-29466-20/0 AUS CC5281 21-29466-21/0 AZD		
Toledo 1.6L i				05/91 → 03/99		124	BM360 (Fibre)	DM368	EG873
EZ	1595	4	81.00	Injection, SOHC	52-54/ 71-73	30-026807-30	21-26807-20/0		
1F	1595	4	81.00	Monomotronic, SOHC	53/55/ 72/75				
ABN	1595	4	81.00	Injection, SOHC	54-55/ 73-75				
Toledo 1.6L i				11/96 → 03/99		125	AY940 (MLS)	CY941	
AFT	1595	4	81.00	Injection, SOHC	74/101	30-028383-00	21-28383-21/0		
Toledo 1.8L 16V				05/91 → 03/99		126	BM360 (Fibre)	DM365	ET811
Toledo 1.8L GT Mk I				05/91 → 11/92			30-026807-30	21-26807-21/0	(22-26554-40/0)
PL	1781	4	81.00	K-Jetronic	95/129				
KR	1781	4	81.00	Injection, DOHC	98-102/ 133- 139				
Toledo 1.8L 20V				04/99 → 05/06		127	AY970 (MLS)	EY841	EY841
AGN/APG	1781	4	81.00	MPi, DOHC	92/125	30-028495-00	22-28897-02/0 AGN		
Toledo 1.8L 20VT				05/01 → 05/06		128	AY970 (MLS)	CY971	EY841
AUQ	1781	4	81.00	Injection, DOHC	132/180	30-028495-00	21-28495-21/0	22-28897-02/0	











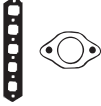

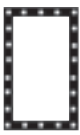

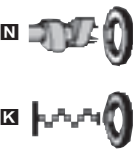





								
HBS246 ® (22-33024B) M10x1.50x120mm (x10)	JD5340 ■ (x4) (50-029939-00) JD600 ■ 31-028454-00	JP024 50-027505-00	HR397 [57] 34-000410-00 JH5117 (50-030046-00)	HR816 ■ 24-30653-85/0	NA5124 32x47x10mm, PTFE (50-319433-00) NA5106 ■ 35x48x10mm, PTFE (50-319430-00) LK5008 ■ [3] 85x131x15.7mm, PTFE (50-319472-00)	HL5034 [245] ■	 AC5220  AC5280  AY940  AY970  AY980  BM360  JC152  JC478  JD281  JD282  JD5228  JD5235  JD5293  JD5298  JD5373  JD599  JD600  JD604  JD605 JD607 PA459 HL457	
HBS246 ® (22-33024B) M10x1.50x120mm (x10)	JD5340 ■ (x4) (50-029939-00) JD5293 ■ (31-029816-00)	JM5205 50-029938-00 (Rubber)	HR397 [57] 34-000410-00	HR817 ■ 24-30614-78/0	NA5124 32x47x10mm, PTFE (50-319433-00) NA5106 ■ 35x48x10mm, PTFE (50-319430-00) LK5008 ■ [3] 85x131x15.7mm, PTFE (50-319472-00)	HL5034 [245] ■		
HBS316 ® (22-33036B) M9x1.25x97mm (x10)	JD5228 ■ (x4) (50-029071-00) AZD JD5373 ■ (31-029966-00) AUS JD5298 ■ (31-029825-00)	HR397 [57] 34-000410-00	HR397 [57] 34-000410-00	HR791 ■ 24-30614-76/0	NA5180 (x2) 27x42x8mm, FPM (50-319484-00) NA5185 ■ 32x42x6mm, FPM (50-319489-00) LK5011 ■ [3] [78] 85x131x15.94mm, PTFE AUS	KK5551 [81]		
HBS043 ® (22-39001B) M11x1.50x95mm (x10)	JC478 ■ 31-026397-00 →Eng.1F 188 126 ABN/EZ PA459 ■ 50-024870-00 (NBR) →Eng.1F 188 126 ABN/EZ JD5235 ■ (31-028554-00) Eng.1F 188 127 → JC152 ■ (x4) 31-026555-00	HL457 ■ [79] 24-25753-01/0 (Cork) HM5053 ■ [80] 24-28543-00/0 (ACM)	JJ140 (31-026554-10)	HR569 ■ 24-30667-00/0	NA5001 32x47x10mm, FPM (50-303185-50) NA5001 ■ 32x47x10mm, FPM (50-303185-50) NA5133 ■ 85x105x11mm, FPM (24-30727-87/0)	HL5020 [245] ■ KA5020 [13]		
HBS043 ® (22-39001B) M11x1.50x95mm (x10)	JD281 ■ (31-027904-00) JD599 ■ (31-027926-00) JD600 ■ 31-028454-00 ⊙ JF205 (31-025070-00)	JP024 50-027505-00		HR816 ■ 24-30653-85/0	NA5001 32x47x10mm, FPM (50-303185-50) NA5001 ■ 32x47x10mm, FPM (50-303185-50) NA5133 ■ 85x105x11mm, FPM (24-30727-87/0)	HL5020 [245] ■ NA5278 [54]		
HBS028 ® (22-39004B) M11x1.50x147mm (x10)	JD281 ■ (31-027904-00) JD282 ■ (x4) (31-026880-00) ⊙ JF205 (31-025070-00)	HL606 ■ 24-26237-01/0	JJ140 (31-026554-10)	HR816 ■ (x2) 24-30653-85/0	NA5001 32x47x10mm, FPM (50-303185-50) NA5001 ■ 32x47x10mm, FPM (50-303185-50) NA5133 ■ 85x105x11mm, FPM (24-30727-87/0)	HL5020 [245] ■		
HBS268 ® (22-33031B) M10x1.50x120mm (x10)	JD607 ■ 50-028924-00 JD605 ■ 31-028826-00 ⊙ JF205 (31-025070-00)	HL732 ■ 24-28815-00/0	HR397 [57] 34-000410-00 JH5117 (50-030046-00)	HR822 ■	NA5124 (x2) 32x47x10mm, PTFE (50-319433-00) NA5106 ■ 35x48x10mm, PTFE (50-319430-00) LK5003 ■ [3] 85x131x15.7mm, PTFE (50-319434-00)	HL5040 [245] ■		
HBS268 ® (22-33031B) M10x1.50x120mm (x10)	JD604 ■ (31-028824-00) JD605 ■ 31-028826-00	HL732 ■ 24-28815-00/0	HR397 [57] 34-000410-00	HR822 ■	NA5124 32x47x10mm, PTFE (50-319433-00) NA5106 ■ 35x48x10mm, PTFE (50-319430-00) LK5003 ■ [3] 85x131x15.7mm, PTFE (50-319434-00)	HL5034 [245] ■		



KW/PS



Toledo 1.8L i				05/91 → 12/96	129	BM360 (Fibre)	DM368	EG873
RP	1781	4	81.00		66/89	30-026807-30	21-26807-20/0	
Toledo 1.8L i				11/93 → 12/96	130	BM360 (Fibre)	DM366	
ABS	1781	4	81.00	Injection, SOHC	66/90	30-026807-30	21-26807-26/0	
ADZ	1781	4	81.00	Motronic, SOHC	66/90	→ Eng.ADZ 011 565 ABS BZ910 (MLS) 30-027935-00 Eng.ADZ 011 566 →	ABS DM367 21-26807-30/0 → Eng.ADZ 011 565 DZ910 21-27935-20/0 Eng.ADZ 011 566 →	
Toledo 1.9L D Diesel				05/91 → 03/99	131	BV850 (MLS), 1.53mm, 1 Hole	DV850▲	EC030 [8]
Toledo 1.9L SDI Diesel				12/95 → 03/99		30-028545-00	21-26557-20/0	22-26384-04/0
Toledo 1.9L TD Diesel				05/91 → 03/99		BV860 (MLS), 1.57mm, 2 Holes		
1Y	1896	4	79.50		47/64	30-028546-00		
AAZ	1896	4	79.50	SOHC	55/75	BV870 (MLS), 1.61mm, 3 Holes 30-028547-00		
Toledo 1.9L SDI Diesel				11/99 → 06/04	132	BZ040 (MLS), 1.47mm, 1 Hole	DZ010▲☒	EC060 [8]
AQM	1896	4	79.50	Direct Injection, SOHC	50/68	30-028915-10 BZ050 (MLS), 1.57mm, 2 Holes 30-028916-10 BZ060 (MLS), 1.67mm, 3 Holes 30-028917-10	21-26556-20/0	22-28897-00/0
Toledo 1.9L TDI Diesel				04/99 → 05/06	133	BZ040 (MLS), 1.47mm, 1 Hole	DZ010▲☒	EC060 [8]
AGR/ALH	1896	4	79.50	Direct Injection, SOHC	66/90	30-028915-10	21-26556-20/0	22-28897-00/0
AHF/ASV	1896	4	79.50	Direct Injection, SOHC	81/110	BZ050 (MLS), 1.57mm, 2 Holes 30-028916-10 BZ060 (MLS), 1.67mm, 3 Holes 30-028917-10		
Toledo 1.9L TDI Diesel				10/00 → 05/06	134	AF5381 (MLS), 1.49mm, 1 Hole	CC5230▲	EC060 [8]
ARL	1896	4	79.50	Direct Injection, SOHC	110/150	30-030098-10 AF5391 (MLS), 1.57mm, 2 Holes 30-030099-10 AF5401 (MLS), 1.65mm, 3 Holes 30-030100-10	21-29463-21/0	22-28897-00/0
Toledo 1.9L TDI Diesel				05/03 → 05/06	135	AF5381 (MLS), 1.49mm, 1 Hole	CC5230▲	EC060 [8]
ASZ	1896	4	79.50	Direct Injection, SOHC	96/130	30-030098-10 AF5391 (MLS), 1.57mm, 2 Holes 30-030099-10 AF5401 (MLS), 1.65mm, 3 Holes 30-030100-10	21-29463-21/0	22-28897-00/0











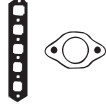

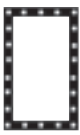

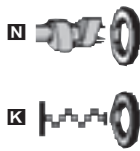









								
HBS043 Ⓢ (22-39001B) M11x1.50x95mm (x10)	JC478 ■ 31-026397-00 PA459 ■ 50-024870-00 (NBR) JC152 ■ (x4) 31-026555-00	HL457 ■ [79] 24-25753-01/0 (Cork) HM5053 ■ [80] 24-28543-00/0 (ACM)	JJ140 (31-026554-10)	HR569 ■ 24-30667-00/0	NA5001 32x47x10mm, FPM (50-303185-50) NA5001 ■ 32x47x10mm, FPM (50-303185-50) NA5133 ■ 85x105x11mm, FPM (24-30727-87/0)	HL5020 [245]■ KA5020 [13]		 BM360  BV850, BV860, BV870  BZ040, BZ050, BZ060
HBS043 Ⓢ (22-39001B) M11x1.50x95mm (x10)	JC478 ■ 31-026397-00 →Eng.ADZ 011 565 ABS PA459 ■ 50-024870-00 (NBR) →Eng.ADZ 011 565 ABS JD5235 ■ (31-028554-00) Eng.ADZ 011 566→ JC152 ■ (x4) 31-026555-00 ABS JD600 ■ 31-028454-00 ADZ	JP024 50-027505-00 ADZ HL457 ■ [79] 24-25753-01/0 (Cork) ABS HM5053 ■ [80] 24-28543-00/0 (ACM) ABS	JJ140 (31-026554-10) ABS	HR569 ■ 24-30667-00/0 →Eng.ADZ 011 565 ABS HR816 ■ 24-30653-85/0 Eng.ADZ 011 566→	NA5001 32x47x10mm, FPM (50-303185-50) NA5001 ■ 32x47x10mm, FPM (50-303185-50) NA5133 ■ 85x105x11mm, FPM (24-30727-87/0)	HL5020 [245]■		 BZ910  JC152  JC478  JD170  JD5235  JD600
HBS018 Ⓢ (22-39024B) M12x1.75x115mm (x10)	JD170 ■ 31-026556-10 JC152 ■ (x4) 31-026555-00	JN914 50-026557-10 HM5058 ■ 24-26557-00/0	JH5023 (31-029043-00)	HR569 ■ 24-30667-00/0	NA5001 32x47x10mm, FPM (50-303185-50) NA5001 ■ 32x47x10mm, FPM (50-303185-50) NA5133 ■ 85x105x11mm, FPM (24-30727-87/0)	HL5020 [245]■ NA5278 [54]		 PA459  HL457
HBS018 Ⓢ (22-39024B) M12x1.75x115mm (x10)	JD170 ■ 31-026556-10 JC152 ■ (x4) 31-026555-00		HR397 [57] 34-000410-00	HR816 ■ 24-30653-85/0	NA5001 32x47x10mm, FPM (50-303185-50) NA5106 ■ 35x48x10mm, PTFE (50-319430-00) LK5003 ■ [3] 85x131x15.7mm, PTFE (50-319434-00)			 JN914  JP024
HBS018 Ⓢ (22-39024B) M12x1.75x115mm (x10)	JD170 ■ 31-026556-10 JC152 ■ (x4) 31-026555-00		HR397 [57] 34-000410-00	HR816 ■ 24-30653-85/0	NA5001 32x47x10mm, FPM (50-303185-50) NA5106 ■ 35x48x10mm, PTFE (50-319430-00) NB716 ■ 35x48x10mm, FPM (50-306067-50) LK5003 ■ [3] 85x131x15.7mm, PTFE (50-319434-00)	NA5278 [54]		 JH5023
HBS018 Ⓢ (22-39024B) M12x1.75x115mm (x10)	JD170 ■ 31-026556-10 JD600 ■ 31-028454-00	JM5203 50-029934-00	HR397 [57] 34-000410-00	HR816 ■ 24-30653-85/0	NA5124 32x47x10mm, PTFE (50-319433-00) NA5106 ■ 35x48x10mm, PTFE (50-319430-00) LK5003 ■ [3] 85x131x15.7mm, PTFE (50-319434-00)	HL5034 [245]■		 JJ140
HBS300 Ⓢ (22-33034B) M12x1.75x166mm (x10)	JD170 ■ 31-026556-10 JD600 ■ 31-028454-00	JM5203 50-029934-00	HR397 [57] 34-000410-00	HR816 ■ 24-30653-85/0	NA5124 32x47x10mm, PTFE (50-319433-00) NA5106 ■ 35x48x10mm, PTFE (50-319430-00) LK5003 ■ [3] 85x131x15.7mm, PTFE (50-319434-00)	HL5034 [245]■		



KW/PS



Toledo 1.9L TDI Diesel		10/04 →		136				CC5230▲		EF5380	
BJB/BKC/BLS/BXE	1896	4	79.50	Direct Injection, SOHC	77/105	AF5381 (MLS), 1,49mm, 1 Hole 30-030098-10 AF5391 (MLS), 1,57mm, 2 Holes 30-030099-10 AF5401 (MLS), 1,65mm, 3 Holes 30-030100-10		21-29463-21/0 BJB/BXC/BXE		22-30369-00/0	
Toledo 1.9L TDI Diesel		08/95 → 03/99		137				DX800▲		ECO30 [8]	
IZ	1896	4	79.50	SOHC	66/89	BX800 (MLS), 1.45mm, 1 Hole 30-028686-00		21-27921-20/0		22-26384-04/0 →Eng.AHU 390 000 IZ	
AHU	1896	4	79.50		66/90	BX810 (MLS), 1.53mm, 2 Holes 30-028687-00 BX820 (MLS), 1.61mm, 3 Holes 30-028688-00					
Toledo 1.9L TDI Diesel		11/96 → 03/99		138				DX800▲		ECO30 [8]	
AFN	1896	4	79.50	SOHC	81/110	BX800 (MLS), 1.45mm, 1 Hole 30-028686-00 BX810 (MLS), 1.53mm, 2 Holes 30-028687-00 BX820 (MLS), 1.61mm, 3 Holes 30-028688-00		21-27921-20/0 →Eng.AFN 002 000 DX801▲ 21-27921-21/0 Eng.AFN 002 001 →		22-26384-04/0	
Toledo 2.0L TDI Diesel		01/06 →		139						EF5380	
BMN	1968	4	81.00	Direct Injection, DOHC	125/170	AG8970 (MLS), 1.55mm, 1 Hole 30-030249-00 AG8800 (MLS), 1.63mm, 2 Holes (30-030213-00) AG8960 (MLS), 1.71mm, 3 Holes (30-030248-00)				22-30369-00/0	
Toledo 2.0L TDI Diesel		01/06 →		140						EF5380	
BMM	1968	4	81.00	Direct Injection, SOHC	103/140	AG9630 (MLS), 1.45mm, 1 Hole 30-030349-00 AG9640 (MLS), 1.53mm, 2 Holes AG9650 (MLS), 1.61mm, 3 Holes				22-30369-00/0	
Toledo 2.0L TDI Diesel		09/04 →		141						EF5380	
AZV	1968	4	81.00	Direct Injection, DOHC	100/136	AG8970 (MLS), 1.55mm, 1 Hole 30-030249-00				22-30369-00/0	
BKD	1968	4	81.00	Direct Injection, DOHC	103/140	AG8800 (MLS), 1.63mm, 2 Holes (30-030213-00) AG8960 (MLS), 1.71mm, 3 Holes (30-030248-00)					
Toledo 2.0L FSI		10/04 →		142						EG9600	
BLR/BLY/BVY/BVZ	1984	4	82.50	Injection, DOHC	110/150	AG9600 (MLS) 30-030352-00				22-30370-00/0	
Toledo 2.0L i		05/91 → 03/99		143						EB970	
2E	1984	4	82.50	Digifant	85/115	BT810 (Fibre) 30-027257-20		DT816 21-27257-24/0 2E		22-27500-01/0 AGG	
AGG	1984	4	82.50	Injection, SOHC	85/115	BY750 (MLS) 30-027930-00 AGG		DY753 21-27930-23/0 AGG		22-30370-00/0 2E	

								
HBS300 ® (22-33034B) M12x1.75x166mm (x10)	JD170 ■ 31-026556-10 JD600 ■ 31-028454-00 BJB/BXC/BXE	JM5203 50-029934-00 BJB/BXC/BXE	HR397 [57] 34-000410-00	HR816 ■ 24-30653-85/0	NA NA5124 32x47x10mm, PTFE (50-319433-00) NA NA5106 ■ 35x48x10mm, PTFE (50-319430-00) LK LK5012 ■ [3] [85] 85x132x15.7mm, ACM (50-319535-00)	HL5034 [245]■	 BT810  BX800, BX810, BX820  BY750  JC152  JD170  JD483  JD600	
HBS018 ® (22-39024B) M12x1.75x115mm (x10)	JD170 ■ 31-026556-10 JC152 ■ (x4) 31-026555-00	JP003 50-027921-00	JJ609 (50-027500-00) (ACM)	HR569 ■ 24-30667-00/0 →Eng.1Z 770 000 AHU HR816 ■ 24-30653-85/0 Eng.1Z 770 001→	NA NA5001 32x47x10mm, FPM (50-303185-50) NA NA5001 ■ 32x47x10mm, FPM (50-303185-50) NA NA5133 ■ 85x105x11mm, FPM (24-30727-87/0) →Eng.AHU 390 000 1Z LK LK5006 ■ [3] 85x131x16mm, PTFE (50-319448-00) Eng.AHU 390 001→	HL5020 [245]■ NA5278 [54]	 JC152  JD170  JD483  JD600	
HBS018 ® (22-39024B) M12x1.75x115mm (x10)	JD170 ■ 31-026556-10 JC152 ■ (x4) 31-026555-00	JP003 50-027921-00	JJ609 (50-027500-00) (ACM)	HR569 ■ 24-30667-00/0 →Eng.AFN 002 000 HR816 ■ 24-30653-85/0 Eng.AFN 002 001→	NA NA5001 32x47x10mm, FPM (50-303185-50) NA NA5001 ■ 32x47x10mm, FPM (50-303185-50) NA NA5133 ■ 85x105x11mm, FPM (24-30727-87/0)	HL5020 [245]■ NA5278 [54]	 JN964  JP003  JP024	
HBS364 ® (22-39032B) M12x1.75x149mm (x10)	JD5805 ■ 50-030225-00 JD5806 ■ 31-030226-00		HR397 [57] 34-000410-00	HR791 ■ 24-30614-76/0	NA NA5124 (x2) 32x47x10mm, PTFE (50-319433-00) NA NA5106 ■ 35x48x10mm, PTFE (50-319430-00) LK LK5012 ■ [3] [85] 85x132x15.7mm, ACM (50-319535-00)	KK5522 [86]	 JP024  JJ140	
HBS300 ® (22-33034B) M12x1.75x166mm (x10)	JD170 ■ 31-026556-10		HR397 [57] 34-000410-00	HR816 ■ 24-30653-85/0	NA NA5124 32x47x10mm, PTFE (50-319433-00) NA NA5106 ■ 35x48x10mm, PTFE (50-319430-00) LK LK5012 ■ [3] [85] 85x132x15.7mm, ACM (50-319535-00)		 JJ140  JJ609	
HBS364 ® (22-39032B) M12x1.75x149mm (x10)	JD5805 ■ 50-030225-00 JD5806 ■ 31-030226-00 JD5815 ■ 31-030235-00	JM7031 50-030223-00 (Rubber)	HR397 [57] 34-000410-00	HR791 ■ 24-30614-76/0	NA NA5124 (x2) 32x47x10mm, PTFE (50-319433-00) NA NA5106 ■ 35x48x10mm, PTFE (50-319430-00) LK LK5012 ■ [3] [85] 85x132x15.7mm, ACM (50-319535-00)	KK5522 [86]		
HBS363 ® (22-33038B) M10x1.50x122mm (x10)	JD5873 ■ 50-030353-00 (FPM) JD5813 ■ 31-030233-00		HR397 [57] 34-000410-00	HR791 ■ 24-30614-76/0	NA NA5124 32x47x10mm, PTFE (50-319433-00) NA NA5106 ■ 35x48x10mm, PTFE (50-319430-00) LK LK5008 ■ [3] 85x131x15.7mm, PTFE (50-319472-00)			
HBS043 ® (22-39001B) M11x1.50x95mm (x10)	JD483 ■ (31-027352-00) JC152 ■ (x4) 31-026555-00	JN964 50-026423-10 2E JP024 50-027505-00 AGG	JJ140 (31-026554-10) 2E	HR569 ■ 24-30667-00/0 →Eng.2E 265 664 HR816 ■ 24-30653-85/0 Eng.2E 265 665→ AGG	NA NA5001 32x47x10mm, FPM (50-303185-50) NA NA5001 ■ 32x47x10mm, FPM (50-303185-50) NA NA5133 ■ 85x105x11mm, FPM (24-30727-87/0) LK LK5006 ■ [3] 85x131x16mm, PTFE (50-319448-00)	HL5020 [245]■ NA5278 [54]		

SEAT





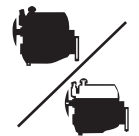





KW/PS



Toledo 2.0L i 16V				11/93 → 03/99	144	BT810 (Fibre)	DT81B
ABF	1984	4	82.50	Injection, DOHC	110/150	30-027257-20 →Eng.ABF 031 251 BY750 (MLS) 30-027930-00 Eng.ABF 031 252→	21-27930-20/0 Eng.ABF 031 252→
Toledo 2.3L V5				04/99 → 05/01	145	AG7800	CG7800
AGZ	2324	5	81.00	Injection, DOHC, V5	110/150		EG7800
Toledo 2.8L				10/00 → 07/01	146	AG5000 (MLS)	CG5010
AUE	2792	6	81.00	Injection, DOHC, V6	150/204	(30-030123-00)	21-30123-10/0 EG7800
Toledo 2.8L 4x4				05/02 → 04/04	147	AG5000 (MLS)	CG5030
BDE	2792	6	81.00	Injection, DOHC, V6	150/204	(30-030123-00)	21-30123-30/0 EG7800

HBS028 ® [22-39004B] M11x1.50x147mm (x10) →Eng.ABF 031 251	JD281 ■ (31-027904-00) JD282 ■ (x4) (31-026880-00) Ⓢ JF205 (31-025070-00)	HL606 ■ 24-26237-01/0 →Eng.ABF 031 251 HL731 ■ 24-27937-00/0 Eng.ABF 031 252→	JJ609 (50-027500-00) (ACM)	HR816 ■ (x2) 24-30653-85/0	NA5001 32x47x10mm, FPM (50-303185-50) NA5001 ■ 32x47x10mm, FPM (50-303185-50) NA5133 ■ 85x105x11mm, FPM (24-30727-87/0)	HL5020 [245] ■	 AG5000 BT810 BY750 JD281 JD282 HL731 JJ609	
HBS461 [22-39034B]			HR397 [57] 34-000410-00		NA5106 ■ 35x48x10mm, PTFE (50-319430-00)			
			HR397 [57] 34-000410-00	HR5062 ■ 24-30614-73/0	NA5106 ■ 35x48x10mm, PTFE (50-319430-00)			
	JD5857 ■ 50-030160-00 (Rubber)	JM7045 50-030133-00 (Rubber)	HR397 [57] 34-000410-00	HR5062 ■ 24-30614-73/0	NA5106 ■ 35x48x10mm, PTFE (50-319430-00)			











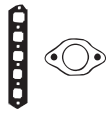

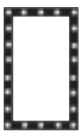

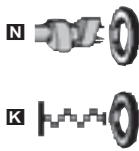

		CC			9			CC			9
135B	Petrol	1289	4	75.50	11	BLS	Diesel	1896	4	79.50	7
136 L	Petrol	1289	4		11	BLT	Diesel	1896	4	79.50	9
136B	Petrol	1289	4	75.50	11	BLX	Petrol	1984	4	82.50	30
781.135	Petrol	1289	4	75.50	11	BLY	Petrol	1984	4	82.50	30
781.135E	Petrol	1289	4	75.50	11	BMD	Petrol	1198	3	76.50	1
AEE	Petrol	1598	4	76.50	12	BME	Petrol	1198	3	76.50	2
AEE	Petrol	1598	4	76.50	16	BME	Petrol	1198	3	76.50	33
AEF	Diesel	1896	4	79.50	13	BMM	Diesel	1968	4	81.00	28
AEG	Petrol	1984	4	82.50	29	BMS	Diesel	1422	3	79.50	36
AEH	Petrol	1595	4	81.00	19	BNM	Diesel	1422	3	79.50	35
AGN	Petrol	1781	4	81.00	21	BNM	Diesel	1422	3	79.50	5
AGP	Diesel	1896	4	79.50	23	BNV	Diesel	1422	3	79.50	36
AGR	Diesel	1896	4	79.50	26	BNV	Diesel	1422	3	79.50	5
AGU	Petrol	1781	4	81.00	22	BSE	Petrol	1595	4	81.00	18
AHF	Diesel	1896	4	79.50	27	BSF	Petrol	1595	4	81.00	18
AKL	Petrol	1595	4	81.00	19	BSS	Diesel	1968	4	81.00	42
ALH	Diesel	1896	4	79.50	26	BSW	Diesel	1896	4	79.50	38
AMD	Petrol	1397	4	75.50	14	BSW	Diesel	1896	4	79.50	7
AME	Petrol	1397	4	75.50	3	BTS	Petrol	1598	4	76.50	37
AMF	Diesel	1422	3	79.50	5	BTS	Petrol	1598	4	76.50	6
APK	Petrol	1984	4	82.50	29	BVX	Petrol	1984	4	82.50	30
AQM	Diesel	1896	4	79.50	23	BVY	Petrol	1984	4	82.50	30
AQW	Petrol	1397	4	75.50	3	BVZ	Petrol	1984	4	82.50	30
AQY	Petrol	1984	4	82.50	10	BXE	Diesel	1896	4	79.50	25
AQY	Petrol	1984	4	82.50	29	BXE	Diesel	1896	4	79.50	40
ARX	Petrol	1781	4	81.00	22	BXW	Petrol	1390	4	76.50	34
ARZ	Petrol	1781	4	81.00	22	BZG	Petrol	1198	3	76.50	2
ASV	Diesel	1896	4	79.50	27	BZG	Petrol	1198	3	76.50	32
ASY	Diesel	1896	4	79.50	8	BZG	Petrol	1198	3	76.50	33
ASZ	Diesel	1896	4	79.50	24	CCSA	Petrol	1595	4	81.00	18
ASZ	Diesel	1896	4	79.50	9	CEVA	Petrol	1198	3	76.50	2
ATD	Diesel	1896	4	79.50	24	OHC	Petrol	1289	4		11
ATD	Diesel	1896	4	79.50	9						
ATZ	Petrol	1397	4	75.50	3						
AUA	Petrol	1390	4	76.50	4						
AUB	Petrol	1390	4	76.50	4						
AUM	Petrol	1781	4	81.00	22						
AUQ	Petrol	1781	4	81.00	22						
AVB	Diesel	1896	4	79.50	41						
AVF	Diesel	1896	4	79.50	41						
AVU	Petrol	1595	4	81.00	17						
AWT	Petrol	1781	4	81.00	39						
AWX	Diesel	1986	4	79.50	41						
AWY	Petrol	1198	3	76.50	1						
AXP	Petrol	1390	4	76.50	15						
AXR	Diesel	1896	4	79.50	9						
AYM	Diesel	2496	6	78.30	44						
AZE	Petrol	1397	4	75.50	3						
AZF	Petrol	1397	4	75.50	3						
AZH	Petrol	1984	4	82.50	29						
AZJ	Petrol	1984	4	82.50	29						
AZL	Petrol	1984	4	82.50	10						
AZM	Petrol	1984	4	82.50	43						
AZQ	Petrol	1198	3	76.50	2						
BBY	Petrol	1390	4	76.50	4						
BBZ	Petrol	1390	4	76.50	4						
BCA	Petrol	1390	4	76.50	15						
BDG	Diesel	2496	6	78.30	45						
BFQ	Petrol	1595	4	81.00	17						
BGU	Petrol	1595	4	81.00	18						
BJB	Diesel	1896	4	79.50	25						
BKC	Diesel	1896	4	79.50	25						
BKD	Diesel	1968	4	81.00	31						
BKY	Petrol	1390	4	76.50	4						
BLF	Petrol	1598	4	76.50	20						
BLR	Petrol	1984	4	82.50	30						
BLS	Diesel	1896	4	79.50	25						
BLS	Diesel	1896	4	79.50	38						
BLS	Diesel	1896	4	79.50	40						



KW/PS



Fabia 1.2L						07/01 →	1	AG8840 (MLS) (30-030217-00)	CG8840 21-27217-00/0	EF5990 22-30371-00/0
AWY/BMD	1198	3	76.50	SOHC	40/54					
Fabia 1.2L						01/03 →	2	AF5990 (MLS) (30-030120-00)	CF5990 21-30120-00/0	EF5990 22-30371-00/0
AZQ/BME	1198	3	76.50	DOHC	47/64					
BZG	1198	3	76.50	Injection, DOHC						
Fabia 1.4L						08/99 →08/02	3	BT580 (Fibre) (30-026560-00)	DT581 21-26560-00/0	
AZE/AZF	1397	4	75.50		44/60					
AME	1397	4	75.50		50/68					
AQW/ATZ	1397	4	75.50	SOHC	50/68					
Fabia 1.4L 16V						10/99 →	4	AB5701 (MLS) 30-029313-10	CB5700☒ 21-29313-20/0	EB5700 [8] 22-29313-00/0
AUA	1390	4	76.50	MPi, SOHC	55/75					
BBY/BKY	1390	4	76.50	DOHC	55/75					
AUB	1390	4	76.50	MPi, DOHC	74/100					
BBZ	1390	4	76.50	DOHC	74/100					
Fabia 1.4L TDI Diesel						04/03 →	5	AD5650 (MLS), 1.45mm, 1 Hole 30-029663-00 AD5660 (MLS), 1.53mm, 2 Holes 30-029664-00 AD5670 (MLS), 1.61mm, 3 Holes 30-029665-00	CD5650▲ 21-29671-20/0 AMF	ED5650 [8] (22-29671-00/0)
BNM	1422	3	79.50	Direct Injection, SOHC	51/70					
AMF	1422	3	79.50	Direct Injection, SOHC	55/75					
BNV	1422	3	79.50	Direct Injection, SOHC	59/80					
Fabia 1.6L						03/07 →	6	AG8850 (MLS) (30-030218-00)		
BTS	1598	4	76.50	Injection, DOHC	77/105					
Fabia 1.9L TDI Diesel						04/07 →	7	AF5381 (MLS), 1.49mm, 1 Hole 30-030098-10 AF5391 (MLS), 1.57mm, 2 Holes 30-030099-10 AF5401 (MLS), 1.65mm, 3 Holes 30-030100-10	CC5230▲ 21-29463-21/0 BSW	EF5380 22-30369-00/0
BLS/BSW	1896	4	79.50	Direct Injection, SOHC	77/105					
Fabia 1.9L SDI Diesel						11/99 →	8	BZ040 (MLS), 1.47mm, 1 Hole 30-028915-10 BZ050 (MLS), 1.57mm, 2 Holes 30-028916-10 BZ060 (MLS), 1.67mm, 3 Holes 30-028917-10	CC5231▲ 21-29463-20/0	
ASY	1896	4	79.50		47/64					
Fabia 1.9L TDI Diesel						01/00 →	9	AF5381 (MLS), 1.49mm, 1 Hole 30-030098-10 AF5391 (MLS), 1.57mm, 2 Holes 30-030099-10 AF5401 (MLS), 1.65mm, 3 Holes 30-030100-10	CC5230▲ 21-29463-21/0	
Fabia 1.9L TDI RS Diesel						06/03 →				
ATD	1896	4	79.50		74/100					
AXR	1896	4	79.50	Direct Injection, SOHC	74/100					
BLT	1896	4	79.50	Direct Injection, SOHC	96/130					
ASZ	1896	4	79.50	PDi, SOHC	96/131					











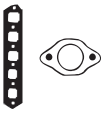

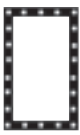

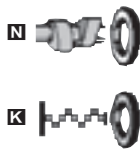







								 AD5650, AD5660, AD5670
HBS479 Ⓢ (22-39036B) M9x1.25x162mm (x8)	JD5807 ■ (x3) 50-030227-00 →Ch.9N 5 044 100 JD5808 ■ (x3) 50-030228-00 Ch.9N 5 044 101→ JD5819 ■ 31-030239-00	HR397 [57] 34-000410-00	HR397 [57] 34-000410-00	HL5002 ■ (24-30614-77/0)	NA5106 ■ 35x48x10mm, PTFE (50-319430-00)			 BT580  BZ040, BZ050, BZ060
HBS471 Ⓢ (22-39035B) M9x1.25x138mm (x8)	JD5811 ■ (x3) (50-030231-00) JD5816 ■ 31-030236-00	HR397 [57] 34-000410-00	HR397 [57] 34-000410-00	HR280 ■ 24-30614-75/0	NA5106 ■ 35x48x10mm, PTFE (50-319430-00)			 JC152  JD170  JD5228  JD5278  JD5279  JD5298  JD600
HBS249 Ⓢ (22-33025B) M9x1.25x138mm (x10)	JD5812 ■ (x2) (31-030232-00) JD5818 ■■ 31-030238-00 (MLS) JD5817 ■ 31-030237-00 (MLS) JD5849 ■■ 31-030259-00 (MLS)	JM5285 (50-026659-00)	HR397 [57] 34-000410-00	HR816 ■ 24-30653-85/0				
HBS249 Ⓢ (22-33025B) M9x1.25x138mm (x10)	JD5228 ■ (x4) (50-029071-00) JD5298 ■ (31-029825-00)	HR397 [57] 34-000410-00	HR397 [57] 34-000410-00	HR791 ■ 24-30614-76/0	NA5180 27x42x8mm, FPM (50-319484-00) NA5185 ■ 32x42x6mm, FPM (50-319489-00)	KA5025 [13] KK5551 [81]		
HBS264 Ⓢ (22-33026B) M12x1.75x166mm (x8)	JD5278 ■ (31-029671-00) JD5279 ■ (31-029710-00)	JM7032 50-030224-00	HR397 [57] 34-000410-00	HR5068 ■ (24-30653-84/0)	NA5124 32x47x10mm, PTFE (50-319433-00) NA5106 ■ 35x48x10mm, PTFE (50-319430-00) LK5003 ■ [3] 85x131x15.7mm, PTFE (50-319434-00)	HL5034 [245]■		
HBS249 Ⓢ (22-33025B) M9x1.25x138mm (x10)	JD5228 ■ (x4) (50-029071-00) JD5814 ■ 31-030234-00	HR397 [57] 34-000410-00	HR397 [57] 34-000410-00	HR791 ■ 24-30614-76/0	NA5106 ■ 35x48x10mm, PTFE (50-319430-00)			
HBS300 Ⓢ (22-33034B) M12x1.75x166mm (x10)	JD170 ■ 31-026556-10 JD600 ■ 31-028454-00 BSW	JM5203 50-029934-00 BSW	HR397 [57] 34-000410-00	HR816 ■ 24-30653-85/0	NA5124 32x47x10mm, PTFE (50-319433-00) NA5106 ■ 35x48x10mm, PTFE (50-319430-00) LK5012 ■ [3] [85] 85x132x15.7mm, ACM (50-319535-00) BLS LK5003 ■ [3] 85x131x15.7mm, PTFE (50-319434-00) BSW			
HBS018 Ⓢ (22-39024B) M12x1.75x115mm (x10)	JD170 ■ 31-026556-10 JC152 ■ (x4) 31-026555-00	JM5203 50-029934-00	HR397 [57] 34-000410-00	HR816 ■ 24-30653-85/0	NA5124 32x47x10mm, PTFE (50-319433-00) NA5106 ■ 35x48x10mm, PTFE (50-319430-00) LK5003 ■ [3] 85x131x15.7mm, PTFE (50-319434-00)	HL5034 [245]■ NA5278 [54]		
HBS300 Ⓢ (22-33034B) M12x1.75x166mm (x10)	JD170 ■ 31-026556-10 JD600 ■ 31-028454-00	JM5203 50-029934-00	HR397 [57] 34-000410-00	HR816 ■ 24-30653-85/0	NA5124 32x47x10mm, PTFE (50-319433-00) NA5106 ■ 35x48x10mm, PTFE (50-319430-00) LK5003 ■ [3] 85x131x15.7mm, PTFE (50-319434-00)	HL5034 [245]■		



KW/PS



Fabia 2.0L					12/99 →	10	AB5370 (MLS)	CB5370■	EB5370 [8]	
AQY/AZL	1984	4	82.50			85/116	30-029314-00	21-29314-20/0	22-29314-00/0	
Favorit 1.3L					08/91 →06/97	11	BT580 (Fibre) (30-026560-00)	DT580		
Favorit 135					10/90 →09/94					
Favorit 135 L					05/89 →09/94					
Favorit 135 X,LX,GLX					01/90 →09/94					
Favorit 136					10/90 →09/94					
OHC	1289	4				40-45/ 55-61				
136 L	1289	4				45/61				
135B	1289	4	75.50			40/54				
781.135/781.135E	1289	4	75.50	OHV		40-50/ 54-68				
136B	1289	4	75.50	Injection		50/68				
Felicia 1.6L					06/97 →06/01	12	BZ180 (MLS), 0.50mm 30-027910-10	DZ181	EB961 [8] 22-28897-03/0 →Eng.AEE 562 757	
Felicia 1.6L GLX					08/95 →03/98					
Felicia 1.6L LX					08/95 →03/98					
AEE	1598	4	76.50	Injection, SOHC		55/75				
Felicia 1.9L D Diesel					10/95 →06/01	13	BV850 (MLS), 1.53mm, 1 Hole 30-028545-00 BV860 (MLS), 1.57mm, 2 Holes 30-028546-00 BV870 (MLS), 1.61mm, 3 Holes 30-028547-00	DV851▲	ECO30 [8] 22-26384-04/0	
AEF	1896	4	79.50			47/64				21-26557-21/0
Octavia 1.4L					04/99 →	14	BT580 (Fibre) (30-026560-00)	DT581		
AMD	1397	4	75.50			44/60			21-26560-00/0	
Octavia 1.4L					06/04 →	15	AB5701 (MLS) 30-029313-10	CB5700☒	EB5700 [8] 22-29313-00/0	
Octavia 1.4L 16V					08/00 →					
AXP/BCA	1390	4	76.50	DOHC		55/75				











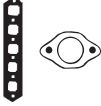

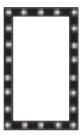

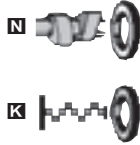

























































								
HBS246 ® (22-33024B) M10x1.50x120mm (x10)	JD5291 ■ (31-029814-00) JD5293 ■ (31-029816-00)	JP024 50-027505-00	HR397 [57] 34-000410-00	HR816 ■ 24-30653-85/0	NA5124 32x47x10mm, PTFE (50-319433-00) NA5106 ■ 35x48x10mm, PTFE (50-319430-00) LK5003 ■ [3] 85x131x15.7mm, PTFE (50-319434-00)	HL5034 [245] ■		 AB5370  BT580  BV850, BV860, BV870
HBS173 ® (22-43001B) M11x1.50x168mm (x7) M11x1.50x133mm (x1) M11x1.50x182mm (x2)	JD5766	JM5285 (50-026659-00)		HR569 ■ 24-30667-00/0	NB786 ■ 42x58x11mm, FPM (50-305941-50) NA5133 ■ 85x105x11mm, FPM (24-30727-87/0)			 BZ180  JC152  JD170  JD5228
HBS075 ® (22-39011B) M11x1.50x110mm (x10)	JD597 ■ ■ 50-350355-00 JD601 ■ 31-028644-00	JP074 50-027907-00 HM5062 ■ 24-27907-00/0	HR397 [57] 34-000410-00	HR816 ■ 24-30653-85/0	NA5001 32x47x10mm, FPM (50-303185-50) NA5001 ■ 32x47x10mm, FPM (50-303185-50) →Eng.AEE 562 757 NA5133 ■ 85x105x11mm, FPM (24-30727-87/0) →Eng.AEE 562 757 NA5185 ■ 32x42x6mm, FPM (50-319489-00) Eng.AEE 562 758→ LK5006 ■ [3] 85x131x16mm, PTFE (50-319448-00) Eng.AEE 562 758→	HL5020 [245] ■		 JD5291  JD5293  JD5298  JD597  JD601
HBS018 ® (22-39024B) M12x1.75x115mm (x10)	JD170 ■ 31-026556-10 JC152 ■ (x4) 31-026555-00 JE5076 (31-028373-00)	JN914 50-026557-10 HM5058 ■ 24-26557-00/0	JH5023 (31-029043-00)	HR816 ■ 24-30653-85/0	NA5001 32x47x10mm, FPM (50-303185-50) NA5001 ■ 32x47x10mm, FPM (50-303185-50) NA5133 ■ 85x105x11mm, FPM (24-30727-87/0) →Eng.AEF 265 000 LK5006 ■ [3] 85x131x16mm, PTFE (50-319448-00) Eng.AEF 265 001→	HL5020 [245] ■		 JN914  JP024  JP074
	JD5812 ■ (x2) (31-030232-00) JD5818 ■ ■ 31-030238-00 (MLS) JD5817 ■ 31-030237-00 (MLS) JD5849 ■ ■ 31-030259-00 (MLS)	JM5285 (50-026659-00)	HR397 [57] 34-000410-00	HR816 ■ 24-30653-85/0				 JH5023
HBS249 ® (22-33025B) M9x1.25x138mm (x10)	JD5228 ■ (x4) (50-029071-00) JD5298 ■ (31-029825-00)	HR397 [57] 34-000410-00	HR397 [57] 34-000410-00	HR791 ■ 24-30614-76/0	NA5180 27x42x8mm, FPM (50-319484-00) NA5185 ■ 32x42x6mm, FPM (50-319489-00)	KA5025 [13] KK5551 [81]		



KW/PS



Octavia 1.6L						09/96 → 09/00	16	BZ180 (MLS), 0.50mm	DZ181	EB961 [8]
AEE	1598	4	76.50	Injection, SOHC	55/75	30-027910-10		21-27910-21/0	22-28897-03/0 →Eng.AEE 562 757	
Octavia 1.6L						09/00 →	17	AC5220 (MLS)	CC5222	EC5220 [8]
AVU/BFQ	1595	4	81.00	SOHC	75/102	30-029462-00		21-29462-22/0	(22-29462-00/0)	
Octavia 1.6L						06/04 →	18	AC5220 (MLS)	CC5222	
BGU	1595	4	81.00	SOHC	75/102	30-029462-00		21-29462-22/0		
BSE/BSF	1595	4	81.00	Injection, SOHC	75/102					
Octavia 1.6L						02/97 →	19	AC5220 (MLS)	CC5220	EC080 [8]
AEH	1595	4	81.00	Motronic	74/100	30-029462-00		21-29462-20/0	(22-28897-01/0)	
AKL	1595	4	81.00		74/100					
Octavia 1.6L FSI						06/04 →	20	AG8850 (MLS)	CG8850	
BLF	1598	4	76.50	Injection, DOHC	85/115	(30-030218-00)		21-30218-00/0		
Octavia 1.8L						09/96 →	21	AY970 (MLS)	CY971	EY841
Octavia 1.8L 20V						07/98 →		30-028495-00	21-28495-21/0 →Ch.1U V 040 000	22-28897-02/0
AGN	1781	4	81.00	MPI, DOHC	92/125					
Octavia 1.8L T						08/97 →	22	AY970 (MLS)	CY971	EY841
Octavia 1.8L T 4x4						05/01 →		30-028495-00	21-28495-21/0	22-28897-02/0
Octavia RS 1.8L T						05/01 →				
AGU	1781	4	81.00	Injection, DOHC	110/150					
ARX	1781	4	81.00	DOHC	110/150					
ARZ	1781	4	81.00	SOHC	110/150					
AUM	1781	4	81.00	DOHC	110/150					
AUQ	1781	4	81.00	DOHC	132/180					

								
HBS075 Ⓞ (22-39011B) M11x1.50x110mm (x10)	JD597  50-350355-00 JD601  31-028644-00	JP074 50-027907-00 HM5062  24-27907-00/0	HR397 [57] 34-000410-00	HR816  24-30653-85/0	NA5001  32x47x10mm, FPM (50-303185-50) NA5001  32x47x10mm, FPM (50-303185-50) →Eng.AEE 562 757 NA5133  85x105x11mm, FPM (24-30727-87/0) →Eng.AEE 562 757 NA5185  32x42x6mm, FPM (50-319489-00) Eng.AEE 562 758→ LK5006  [3] 85x131x16mm, PTFE (50-319448-00) Eng.AEE 562 758→	HL5020 [245] 	 AC5220  AY970  BZ180  JD5293  JD597  JD600  JD601  JD604  JD605  JD607  JP024  JP074	
HBS246 Ⓞ (22-33024B) M10x1.50x120mm (x10)	JD5340  (x4) (50-029939-00) JD5293  (31-029816-00)	JM5205 50-029938-00 (Rubber)	HR397 [57] 34-000410-00	HR817  24-30614-78/0	NA5124  32x47x10mm, PTFE (50-319433-00) NA5106  35x48x10mm, PTFE (50-319430-00) LK5008  [3] 85x131x15.7mm, PTFE (50-319472-00)	HL5034 [245] 		
HBS246 Ⓞ (22-33024B) M10x1.50x120mm (x10)	JD5340  (x4) (50-029939-00) JD5293  (31-029816-00)	JM5205 50-029938-00 (Rubber)	HR397 [57] 34-000410-00	HR817  24-30614-78/0	NA5124  32x47x10mm, PTFE (50-319433-00) NA5106  35x48x10mm, PTFE (50-319430-00)	HL5034 [245] 		
HBS246 Ⓞ (22-33024B) M10x1.50x120mm (x10)	JD5340  (x4) (50-029939-00) JD600  31-028454-00  JF211 (31-028926-00)	JP024 50-027505-00	HR397 [57] 34-000410-00 JH5117 (50-030046-00)	HR816  24-30653-85/0	NA5124  32x47x10mm, PTFE (50-319433-00) NA5106  35x48x10mm, PTFE (50-319430-00) LK5008  [3] 85x131x15.7mm, PTFE (50-319472-00)	HL5034 [245] 		
HBS249 Ⓞ (22-33025B) M9x1.25x138mm (x10)	JD5809  31-030229-00 JD5814  31-030234-00	HR397 [57] 34-000410-00	HR397 [57] 34-000410-00	HR791  24-30614-76/0	NA5106  35x48x10mm, PTFE (50-319430-00) LK5013  [3] [118] 85x111x15.5mm			
HBS268 Ⓞ (22-33031B) M10x1.50x120mm (x10) Eng.AGN 107 001→	JD604  (31-028824-00) →Ch.1U V 040 000 JD607  50-028924-00 Ch.1U W 000 001→ JD605  31-028826-00  JF205 (31-025070-00)	HL732  24-28815-00/0	HR397 [57] 34-000410-00 JH5117 (50-030046-00)	HR822 	NA5124 (x2)  32x47x10mm, PTFE (50-319433-00) NA5106  35x48x10mm, PTFE (50-319430-00) LK5003  [3] 85x131x15.7mm, PTFE (50-319434-00)	HL5040 [245] 		
HBS268 Ⓞ (22-33031B) M10x1.50x120mm (x10)	JD604  (31-028824-00) JD605  31-028826-00	HL732  24-28815-00/0	HR397 [57] 34-000410-00 JH5117 (50-030046-00) AGU / ARZ	HR822 	NA5124 (x2)  32x47x10mm, PTFE (50-319433-00) NA5106  35x48x10mm, PTFE (50-319430-00) LK5003  [3] 85x131x15.7mm, PTFE (50-319434-00)	HL5040 [245] 		



KW/PS

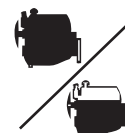

Octavia 1.9L SDI Diesel				06/97 →	23				
AGP	1896	4	79.50		50/68	SDi	BZ010 (MLS), 1.45mm, 1 Hole 30-028910-10 →Eng.AGP 028 000 BZ020 (MLS), 1.53mm, 2 Holes 30-028911-10 →Eng.AGP 028 000 BZ030 (MLS), 1.61mm, 3 Holes 30-028912-10 →Eng.AGP 028 000 BZ040 (MLS), 1.47mm, 1 Hole 30-028915-10 Eng.AGP 028 001 → AQM BZ050 (MLS), 1.57mm, 2 Holes 30-028916-10 Eng.AGP 028 001 → AQM BZ060 (MLS), 1.67mm, 3 Holes 30-028917-10 Eng.AGP 028 001 → AQM	DZ010 ▲☒ 21-26556-20/0 AGP	EC060 [8] 22-28897-00/0
AQM	1896	4	79.50	50/68					
Octavia 1.9L TDI Diesel				01/03 →	24				
Octavia 1.9L TDI 4x4 Diesel				09/00 →					
ATD	1896	4	79.50		74/100	PDi, SOHC	AF5381 (MLS), 1.49mm, 1 Hole 30-030098-10 AF5391 (MLS), 1.57mm, 2 Holes 30-030099-10 AF5401 (MLS), 1.65mm, 3 Holes 30-030100-10	CC5231 ▲ 21-29463-20/0	EB5370 [8] 22-29314-00/0
ASZ	1896	4	79.50	96/131					
Octavia 1.9L TDI Diesel				06/04 →	25				
BJB/BKC	1896	4	79.50		77/105	Direct Injection	AF5381 (MLS), 1.49mm, 1 Hole 30-030098-10 AF5391 (MLS), 1.57mm, 2 Holes 30-030099-10 AF5401 (MLS), 1.65mm, 3 Holes 30-030100-10	CC5230 ▲ 21-29463-21/0 BKC / BJB / BXE	EF5380 22-30369-00/0
BLS/BXE	1896	4	79.50	77/105	Direct Injection, SOHC				
Octavia 1.9L TDI Diesel				09/96 →	26				
AGR	1896	4	79.50		66/89	Direct Injection, SOHC	BZ010 (MLS), 1.45mm, 1 Hole 30-028910-10 →Eng.AGR 151 000 BZ020 (MLS), 1.53mm, 2 Holes 30-028911-10 →Eng.AGR 151 000 BZ030 (MLS), 1.61mm, 3 Holes 30-028912-10 →Eng.AGR 151 000 BZ040 (MLS), 1.47mm, 1 Hole 30-028915-10 Eng.AGR 151 001 → ALH BZ050 (MLS), 1.57mm, 2 Holes 30-028916-10 Eng.AGR 151 001 → ALH BZ060 (MLS), 1.67mm, 3 Holes 30-028917-10 Eng.AGR 151 001 → ALH	DZ010 ▲☒ 21-26556-20/0	EC060 [8] 22-28897-00/0
ALH	1896	4	79.50	66/89					

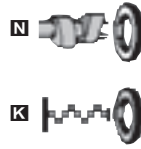
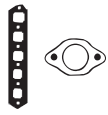

BZ010, BZ020,
BZ030



BZ040, BZ050,
BZ060



JC152



JD170



JD600

HBS018Ⓢ
(22-39024B)
M12x1.75x115mm (x10)

JD170■
31-026556-10
JC152■ (x4)
31-026555-00
AGP
JD600■
31-028454-00
AQM
 JE5076
(31-028373-00)

HR397 [57]
34-000410-00

HR816■
24-30653-85/0

NA5001 32x47x10mm, FPM
(50-303185-50)
 NA5106■ 35x48x10mm, PTFE
(50-319430-00)
 LK5003■ [3] 85x131x15.7mm, PTFE
(50-319434-00)

NA5278 [54]

HBS300Ⓢ
(22-33034B)
M12x1.75x166mm (x10)

JD170■
31-026556-10
JC152■ (x4)
31-026555-00

JM5203
50-029934-00

HR397 [57]
34-000410-00

HR816■
24-30653-85/0

NA5124 32x47x10mm, PTFE
(50-319433-00)
 NA5106■ 35x48x10mm, PTFE
(50-319430-00)
 LK5003■ [3] 85x131x15.7mm, PTFE
(50-319434-00)

HL5034 [245]■

HBS300Ⓢ
(22-33034B)
M12x1.75x166mm (x10)

JD170■
31-026556-10
JD600■
31-028454-00
BKC / BJB / BXE

JM5203
50-029934-00
BKC / BJB / BXE

HR397 [57]
34-000410-00

HR816■
24-30653-85/0

NA5124 32x47x10mm, PTFE
(50-319433-00)
 NA5106■ 35x48x10mm, PTFE
(50-319430-00)
 LK5012■ [3] [85] 85x132x15.7mm, ACM
(50-319535-00)

HL5034 [245]■

HBS018Ⓢ
(22-39024B)
M12x1.75x115mm (x10)

JD170■
31-026556-10
JC152■ (x4)
31-026555-00

HR397 [57]
34-000410-00

HR816■
24-30653-85/0

NA5001 32x47x10mm, FPM
(50-303185-50)
 NB716■ 35x48x10mm, FPM
(50-306067-50)
 LK5003■ [3] 85x131x15.7mm, PTFE
(50-319434-00)











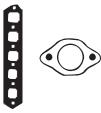

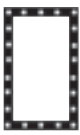

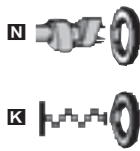



NA5278 [54]



KW/PS



Octavia 1.9L TDI Diesel		08/97 →		27		BZ010 (MLS), 1.45mm, 1 Hole		DZ010▲☒		EC060 [8]	
AHF	1896	4	79.50	Direct Injection, SOHC	81/110	30-028910-10	→Eng.AHF 140 000	21-26556-20/0	22-28897-00/0		
ASV	1896	4	79.50	SOHC	81/110	BZ020 (MLS), 1.53mm, 2 Holes	30-028911-10				
						→Eng.AHF 140 000	BZ030 (MLS), 1.61mm, 3 Holes				
						30-028912-10	→Eng.AHF 140 000				
						BZ040 (MLS), 1.47mm, 1 Hole	30-028915-10				
						Eng.AHF 140 001 →	ASV				
						BZ050 (MLS), 1.57mm, 2 Holes	30-028916-10				
						Eng.AHF 140 001 →	ASV				
						BZ060 (MLS), 1.67mm, 3 Holes	30-028917-10				
						Eng.AHF 140 001 →	ASV				
Octavia 2.0L TDI Diesel		11/05 →		28		AG9630 (MLS), 1.45mm, 1 Hole				EF5380	
BMM	1968	4	81.00	Direct Injection, DOHC	103/140	30-030349-00		22-30369-00/0			
						AG9640 (MLS), 1.53mm, 2 Holes					
						AG9650 (MLS), 1.61mm, 3 Holes					
Octavia 2.0L		04/99 →		29		AB5370 (MLS)		CB5370■		EB5370 [8]	
Octavia 2.0L 4x4						30-029314-00		21-29314-20/0 APK / AQY / AZH	22-29314-00/0		
AEG	1984	4	82.50		85/116						
APK	1984	4	82.50	SOHC	85/116						
AQY/AZH	1984	4	82.50		85/116						
AZJ	1984	4	82.50	Injection, SOHC	85/116						
Octavia 2.0L FSI		11/04 →		30		AG9600 (MLS)				EG9600	
BLR/BLY/BVY/BVZ	1984	4	82.50	Injection, DOHC	110/150	30-030352-00		22-30370-00/0			
BLX/BVX	1984	4	82.50	Injection, DOHC							
Octavia 2.0L TDI 16V Diesel		06/04 →		31		AG8970 (MLS), 1.55mm, 1 Hole				EF5380	
BKD	1968	4	81.00	Direct Injection, DOHC	103/140	30-030249-00		22-30369-00/0			
						AG8800 (MLS), 1.63mm, 2 Holes	(30-030213-00)				
						AG8960 (MLS), 1.71mm, 3 Holes	(30-030248-00)				
Praktik 1.2L		03/07 →		32		AF5990 (MLS)		CF5990		EF5990	
BZG	1198	3	76.50	Injection, DOHC		(30-030120-00)		21-30120-00/0	22-30371-00/0		
Roomster 1.2L		09/06 →		33		AF5990 (MLS)		CF5990		EF5990	
BME	1198	3	76.50	DOHC	47/64	(30-030120-00)		21-30120-00/0	22-30371-00/0		
BZG	1198	3	76.50	Injection, DOHC							











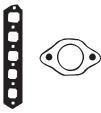

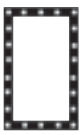

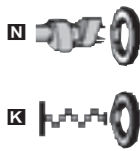







								 AB5370
HBS018 ® (22-39024B) M12x1.75x115mm (x10)	JD170 ■ 31-026556-10 JC152 ■ (x4) 31-026555-00 AHF JD600 ■ 31-028454-00 ASV		HR397 [57] 34-000410-00	HR816 ■ 24-30653-85/0	NA5001 32x47x10mm, FPM (50-303185-50) NB716 ■ 35x48x10mm, FPM (50-306067-50) LK5003 ■ [3] 85x131x15.7mm, PTFE (50-319434-00)	NA5278 [54]		 BZ010, BZ020, BZ030  BZ040, BZ050, BZ060  JC152  JD170  JD5291  JD5293  JD600  LA5204
HBS300 ® (22-33034B) M12x1.75x166mm (x10)	JD170 ■ 31-026556-10		HR397 [57] 34-000410-00	HR816 ■ 24-30653-85/0	NA5124 32x47x10mm, PTFE (50-319433-00) NA5106 ■ 35x48x10mm, PTFE (50-319430-00) LK5012 ■ [3] [85] 85x132x15.7mm, ACM (50-319535-00)		 JM5103	
HBS246 ® (22-33024B) M10x1.50x120mm (x10)	JD5291 ■ (31-029814-00) APK / AQY / AZH JD5340 ■ (x4) (50-029939-00) AZJ LA5204 ■ (x4) (50-350416-00) AEG JD5293 ■ (31-029816-00)	JM5103 (50-029547-00) AEG / AZJ JP024 50-027505-00 APK / AQY / AZH	HR397 [57] 34-000410-00	HR816 ■ 24-30653-85/0	NA5124 32x47x10mm, PTFE (50-319433-00) NA5106 ■ 35x48x10mm, PTFE (50-319430-00) LK5003 ■ [3] 85x131x15.7mm, PTFE (50-319434-00)	HL5034 [245] ■	 JM5103  JP024	
HBS363 ® (22-33038B) M10x1.50x122mm (x10)	JD5873 ■ 50-030353-00 (FPM) JD5813 ■ 31-030233-00		HR397 [57] 34-000410-00	HR791 ■ 24-30614-76/0	NA5124 32x47x10mm, PTFE (50-319433-00) NA5106 ■ 35x48x10mm, PTFE (50-319430-00) LK5008 ■ [3] 85x131x15.7mm, PTFE (50-319472-00)			
HBS364 ® (22-39032B) M12x1.75x149mm (x10)	JD5805 ■ 50-030225-00 JD5806 ■ 31-030226-00 JD5815 ■ 31-030235-00	JM7031 50-030223-00 (Rubber)	HR397 [57] 34-000410-00	HR791 ■ 24-30614-76/0	NA5124 32x47x10mm, PTFE (50-319433-00) NA5106 ■ 35x48x10mm, PTFE (50-319430-00) LK5012 ■ [3] [85] 85x132x15.7mm, ACM (50-319535-00)	HL5034 [245] ■ KK5522 [86]		
HBS471 ® (22-39035B) M9x1.25x138mm (x8)	JD5811 ■ (x3) (50-030231-00) JD5816 ■ 31-030236-00	HR397 [57] 34-000410-00	HR397 [57] 34-000410-00	HR280 ■ 24-30614-75/0	NA5106 ■ 35x48x10mm, PTFE (50-319430-00)			
HBS471 ® (22-39035B) M9x1.25x138mm (x8)	JD5811 ■ (x3) (50-030231-00) JD5816 ■ 31-030236-00	HR397 [57] 34-000410-00	HR397 [57] 34-000410-00	HR280 ■ 24-30614-75/0	NA5106 ■ 35x48x10mm, PTFE (50-319430-00)			



KW/PS



Roomster 1.4L				09/06 →	34	AB5701 (MLS)	CB5700	EB5700 [8]
BXW	1390	4	76.50	Injection, DOHC	63/86	30-029313-10	21-29313-20/0	22-29313-00/0
Roomster 1.4L TDI Diesel				09/06 →	35	AD5650 (MLS), 1.45mm, 1 Hole		ED5650 [8]
BNM	1422	3	79.50	Direct Injection, SOHC	51/70	30-029663-00 AD5660 (MLS), 1.53mm, 2 Holes 30-029664-00 AD5670 (MLS), 1.61mm, 3 Holes 30-029665-00		(22-29671-00/0)
Roomster 1.4L TDI Diesel				09/06 →	36	AD5650 (MLS), 1.45mm, 1 Hole		ED5650 [8]
BMS/BNV	1422	3	79.50	Direct Injection, SOHC	59/80	30-029663-00 AD5660 (MLS), 1.53mm, 2 Holes 30-029664-00 AD5670 (MLS), 1.61mm, 3 Holes 30-029665-00		(22-29671-00/0)
Roomster 1.6L				09/06 →	37	AG8850 (MLS)		
BTS	1598	4	76.50	Injection, DOHC	77/105	(30-030218-00)		
Roomster 1.9L TDI Diesel				09/06 →	38	AF5381 (MLS), 1.49mm, 1 Hole	CC5230	EF5380
BLS/BSW	1896	4	79.50	Direct Injection, SOHC	77/105	30-030098-10 AF5391 (MLS), 1.57mm, 2 Holes 30-030099-10 AF5401 (MLS), 1.65mm, 3 Holes 30-030100-10	21-29463-21/0 BSW	22-30369-00/0 BLS
Superb 1.8L T				02/02 →	39	AY970 (MLS)	CY971	EY841
AWT	1781	4	81.00		110/150	30-028495-00	21-28495-21/0	22-28897-02/0
Superb 1.9L TDI Diesel				07/08 →	40	AF5381 (MLS), 1.49mm, 1 Hole	CC5230	EF5380
BLS/BXE	1896	4	79.50	Direct Injection, SOHC	77/105	30-030098-10 AF5391 (MLS), 1.57mm, 2 Holes 30-030099-10 AF5401 (MLS), 1.65mm, 3 Holes 30-030100-10	21-29463-21/0 BXE	22-30369-00/0
Superb 1.9L TDI Diesel				02/02 →	41	AF5381 (MLS), 1.49mm, 1 Hole	CC5230	EB5370 [8]
AVB	1896	4	79.50	Direct Injection, SOHC	74/100	30-030098-10	21-29463-21/0	22-29314-00/0
AVF	1896	4	79.50		96/131	AF5391 (MLS), 1.57mm, 2 Holes		
AWX	1986	4	79.50		96/131	30-030099-10 AF5401 (MLS), 1.65mm, 3 Holes 30-030100-10		
Superb 2.0L TDI Diesel				10/05 →	42	AG9630 (MLS), 1.45mm, 1 Hole		
BSS	1968	4	81.00	Direct Injection, SOHC	103/140	30-030349-00 AG9640 (MLS), 1.53mm, 2 Holes AG9650 (MLS), 1.61mm, 3 Holes		
Superb 2.0L				02/02 →	43	AB5370 (MLS)		EB5370 [8]
AZM	1984	4	82.50	SOHC	85/116	30-029314-00		22-29314-00/0

								
HBS249 ® (22-33025B) M9x1.25x138mm (x10)	JD5228 ■ (x4) (50-029071-00) JD5298 ■ (31-029825-00)	HR397 [57] 34-000410-00	HR397 [57] 34-000410-00	HR791 ■ 24-30614-76/0	NA5180 (x2) 27x42x8mm, FPM (50-319484-00) NA5185 ■ 32x42x6mm, FPM (50-319489-00)			 AB5370  AD5650, AD5660, AD5670
HBS264 ® (22-33026B) M12x1.75x166mm (x8)	JD5278 ■ (31-029671-00) JD5279 ■ (31-029710-00)	JM7032 50-030224-00	HR397 [57] 34-000410-00	HR5068 ■ (24-30653-84/0)	NA5124 32x47x10mm, PTFE (50-319433-00) NA5106 ■ 35x48x10mm, PTFE (50-319430-00) LK5003 ■ [3] 85x131x15.7mm, PTFE (50-319434-00)			 AY970  JD170  JD5228
HBS264 ® (22-33026B) M12x1.75x166mm (x8)	JD5278 ■ (31-029671-00) JD5279 ■ (31-029710-00) BNV	JM7032 50-030224-00 BNV	HR397 [57] 34-000410-00	HR5068 ■ (24-30653-84/0)	NA5124 32x47x10mm, PTFE (50-319433-00) NA5106 ■ 35x48x10mm, PTFE (50-319430-00) LK5003 ■ [3] 85x131x15.7mm, PTFE (50-319434-00)			 JD5278  JD5279  JD5298
HBS249 ® (22-33025B) M9x1.25x138mm (x10)	JD5228 ■ (x4) (50-029071-00) JD5814 ■ 31-030234-00	HR397 [57] 34-000410-00	HR397 [57] 34-000410-00	HR791 ■ 24-30614-76/0	NA5106 ■ 35x48x10mm, PTFE (50-319430-00)			 JD5279  JD5298
HBS300 ® (22-33034B) M12x1.75x166mm (x10)	JD170 ■ 31-026556-10 JD600 ■ 31-028454-00 BSW	JM5203 50-029934-00 BSW	HR397 [57] 34-000410-00	HR816 ■ 24-30653-85/0	NA5124 32x47x10mm, PTFE (50-319433-00) NA5106 ■ 35x48x10mm, PTFE (50-319430-00) LK5012 ■ [3] [85] 85x132x15.7mm, ACM (50-319535-00) BLS LK5003 ■ [3] 85x131x15.7mm, PTFE (50-319434-00) BSW			 JD5341  JD600  JD604  JD605
HBS268 ® (22-33031B) M10x1.50x120mm (x10)	JD604 ■ (31-028824-00) JD605 ■ 31-028826-00  JE5075 (31-027178-00)	HL732 ■ 24-28815-00/0	HR397 [57] 34-000410-00	HR822 ■	NA5124 (x2) 32x47x10mm, PTFE (50-319433-00) NA5106 ■ 35x48x10mm, PTFE (50-319430-00) LK5003 ■ [3] 85x131x15.7mm, PTFE (50-319434-00)	HL5040 [245] ■		 JP024
HBS300 ® (22-33034B) M12x1.75x166mm (x10)	JD170 ■ 31-026556-10 JD600 ■ 31-028454-00 BXE	JM5203 50-029934-00 BXE	HR397 [57] 34-000410-00	HR816 ■ 24-30653-85/0	NA5124 32x47x10mm, PTFE (50-319433-00) NA5106 ■ 35x48x10mm, PTFE (50-319430-00) LK5012 ■ [3] [85] 85x132x15.7mm, ACM (50-319535-00)			
HBS300 ® (22-33034B) M12x1.75x166mm (x10)	JD170 ■ 31-026556-10 JD600 ■ 31-028454-00	JM5203 50-029934-00	HR397 [57] 34-000410-00	HR816 ■ 24-30653-85/0	NA5124 32x47x10mm, PTFE (50-319433-00) NA5106 ■ 35x48x10mm, PTFE (50-319430-00) LK5003 ■ [3] 85x131x15.7mm, PTFE (50-319434-00)	HL5034 [245] ■		
HBS300 ® (22-33034B) M12x1.75x166mm (x10)	JD170 ■ 31-026556-10 JD600 ■ 31-028454-00		HR397 [57] 34-000410-00	HR816 ■ 24-30653-85/0	NA5124 32x47x10mm, PTFE (50-319433-00) NA5106 ■ 35x48x10mm, PTFE (50-319430-00) LK5002 ■ [3] 136x153x21mm, PTFE (50-319427-00)			
HBS246 ® (22-33024B) M10x1.50x120mm (x10)	JD5341 ■ (x4) (50-029940-00) JD600 ■ 31-028454-00  JE5075 (31-027178-00)	JP024 50-027505-00	HR397 [57] 34-000410-00	HR816 ■ 24-30653-85/0	NA5124 32x47x10mm, PTFE (50-319433-00) NA5106 ■ 35x48x10mm, PTFE (50-319430-00) LK5003 ■ [3] 85x131x15.7mm, PTFE (50-319434-00)	HL5034 [245] ■		

SKODA



KW/PS

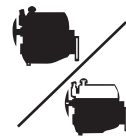

Superb 2.5L TDI Diesel		02/02 →		44			
AYM	2496	6	78.30	V6	114/155	AC5960 (MLS), 1.10mm, 1 Hole (x2) 30-029397-00 AC5970 (MLS), 1.15mm, 2 Holes (x2) 30-029398-00 AC5980 (MLS), 1.20mm, 3 Holes (x2) 30-029399-00	CC5960▲ 21-29397-00/0
Superb 2.5L TDI Diesel		06/03 →		45			
BDG	2496	6	78.30	Direct Injection, DOHC, V6	120/163	AC5960 (MLS), 1.10mm, 1 Hole (x2) 30-029397-00 AC5970 (MLS), 1.15mm, 2 Holes (x2) 30-029398-00 AC5980 (MLS), 1.20mm, 3 Holes (x2) 30-029399-00	CC5960▲ 21-29397-00/0

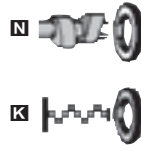
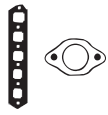

**AC5960, AC5970,
AC5980**

<p>HBS265® (22-33027B) M12x1.50x155mm (x16)</p>	<p>JD5810 (x2) (31-030230-00) JD5851 (x6) 31-030293-00 (Fibre)</p>	<p>HM5223 (x2) 24-30020-00/0 (ACM)</p>	<p>HR397 [57] 34-000410-00</p>	<p>HR5062 24-30614-73/0</p>	<p>NA5001 (x4) 32x47x10mm, FPM (50-303185-50) NB716 35x48x10mm, FPM (50-306067-50)</p>
<p>HBS361® (22-33037B) M12x1.50x159mm (x16)</p>	<p>JD5810 (x2) (31-030230-00) JD5851 (x6) 31-030293-00 (Fibre)</p>	<p>HM5223 (x2) 24-30020-00/0 (ACM)</p>	<p>HR397 [57] 34-000410-00</p>	<p>HR5062 24-30614-73/0</p>	<p>NA5001 (x4) 32x47x10mm, FPM (50-303185-50) NB716 35x48x10mm, FPM (50-306067-50)</p>



KW/PS



Cabrio Convertible 0.6L					03/00 → 01/04	1	AC5660 (MLS)	CC5661	EC5660
M 160 E6AL B03	599	3	63.50		40/55		21-29493-21/0	22-29493-00/0	
M 160 E6AL B05	599	3	63.50	OHV	45/61				
Cabrio Convertible 0.7L					01/03 → 01/04	2	AG8990 (MLS)		
	698	3			45/61	(30-030256-00)			
	698	3			55/75				
Cabrio Convertible 0.8L CDI Diesel					03/01 → 01/04	3	AC5670 (MLS)	CC5670	EC5670
OM 660 DE 8LA	799	3	65.50		30/41	30-029494-00	21-29494-10/0		
City-Coupe 0.6L					07/98 → 01/04	4	AC5660 (MLS)	CC5661	EC5660
M 160 E6AL B04	599	3	63.50	Direct Injection	33/45		21-29493-21/0	22-29493-00/0	
M 160 E6AL B03	599	3	63.50		40/55				
M 160 E6AL B05	599	3	63.50	OHV	45/61				
City-Coupe 0.7L					01/03 → 01/04	5	AG8990 (MLS)		
	698	3			37/50	(30-030256-00)			
	698	3			45/61				
	698	3			55/75				
City-Coupe 0.8L CDI Diesel					11/99 → 01/04	6	AC5670 (MLS)	CC5670	EC5670
OM 660 DE 8LA	799	3	65.50		30/41	30-029494-00	21-29494-10/0		
Crossblade Convertible 0.6L					06/02 →	7	AC5660 (MLS)	CC5661	EC5660
M 160	599	3	63.50		52/71		21-29493-21/0	22-29493-00/0	
Fortwo 0.7L					01/04 →	8	AG8990 (MLS)		
	698	3			37/50	(30-030256-00)			
	698	3			45/61				
	698	3			55/75				
Fortwo 0.8L CDI Diesel					01/07 →	9	AC5670 (MLS)	CC5670	EC5670
Fortwo Cabrio 0.8L CDI Diesel						30-029494-00	21-29494-10/0		
Fortwo Coupe 0.8L CDI Diesel									
OM660.950	799	3		Direct Injection	33/45				
OM 660 DE 8LA	799	3	65.50		30/41				
Roadster Convertible 0.7L					04/03 →	10	AG8990 (MLS)		
Roadster Convertible 0.7L Brabus						(30-030256-00)			
Roadster Coupe 0.7L									
Roadster Coupe 0.7L Brabus									
	698	3			45/61				
	698	3			60/82				
	698	3			74/101				

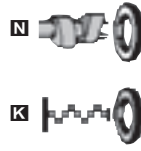
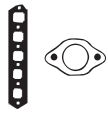

AC5660



AC5670



JD5205



JD5206



JM5162



CC



9



CC



9











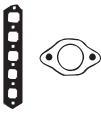

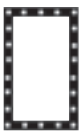





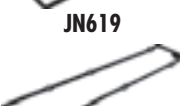













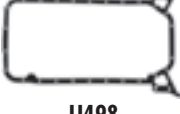
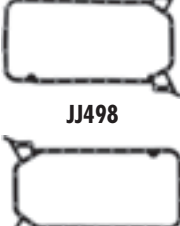





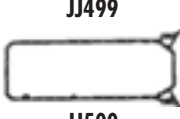









DC23	Diesel	2238	4	88.00	2
E20	Petrol	1998	4	89.90	11
M 104.992	Petrol	3199	6	89.90	18
M 104.992	Petrol	3199	6	89.90	20
M 104.992	Petrol	3199	6	89.90	9
M 104.995	Petrol	3199	6	89.90	10
M 111.970	Petrol	2295	4	90.90	14
M 111.974	Petrol	2295	4	90.90	13
M 161.974	Petrol	2295	4	90.90	13
MB-OM 601 29TD	Diesel	2874	5	76.50	17
MB-OM 601 29TD	Diesel	2874	5	76.50	19
MB-OM 601 29TD	Diesel	2874	5	76.50	8
MB-OM 661	Diesel	2299	4	89.00	15
MB-OM 662	Diesel	2874	5	89.00	16
MB-OM 662	Diesel	2874	5	89.00	7
OM 601.900	Diesel	2299	4	89.00	12
OM 601.940	Diesel	2299	4	89.00	12
OM 601.940	Diesel	2299	4	89.00	15
OM 601.940	Diesel	2299	4	89.00	5
OM 601.941	Diesel	2299	4	89.00	12
OM 601.942	Diesel	2299	4	89.00	12
OM 601.943	Diesel	2299	4	89.00	12
OM 601.970	Diesel	2299	4	89.00	12
OM 662.983	Diesel	2874	5	89.00	17
OM 662.983	Diesel	2874	5	89.00	19
OM 662.983	Diesel	2874	5	89.00	8
XD3	Diesel	2498	4	94.00	6
XD3P	Diesel	2498	4	94.00	6



KWPS

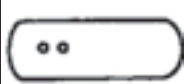

Korando 2.0L 4x4		05/97 →			1	BZ880 (Fibre) 30-027462-10	DV810 21-27462-50/0	
	1998	4			94/128			
Korando 2.2L D 4x4 Diesel		12/88 → 12/96			2	BM370 (Fibre) (30-028348-00)	DM370 (21-28348-21/0)	GM372
DC23	2238	4	88.00	SOHC	50/68			
Korando 2.3L 4x4		01/99 →			3	BZ890 (Fibre) 30-028037-00	DZ891 21-28037-51/0	
	2295	4			105/143			
Korando 2.3L 4x4		05/97 →			4	BZ890 (Fibre) 30-028037-00 BZ900 (Fibre) 30-027971-00	DZ160 21-27971-50/0 DZ891 21-28037-51/0	
	2295	4			103/140			
Korando 2.3L D 4x4 Diesel		12/96 →			5	BW370 (Fibre) 30-027217-20	DW370 21-27217-51/0	EM720 22-24895-01/0
OM 601.940	2299	4	89.00	SOHC	57-59/ 77-80			
Korando 2.5L D 4x4 Diesel		01/95 →			6	BP890 (Fibre), 1.53mm, 2 Notches (30-026144-10) BP900 (Fibre), 1.63mm, 3 Notches (30-026145-10) BP910 (Fibre), 1.73mm, 4 Notches (30-026146-10)	DH890	GH890 (20-24586-05/0)
XD3/XD3P	2498	4	94.00					
Korando 2.9L D Diesel		11/97 →			7	BW380 (Fibre), 1.80mm 30-026270-20	DW381 21-28404-50/0	EN720 22-26946-01/0
Korando 2.9L D 4x4 Diesel		12/96 →						
MB-OM 662	2874	5	89.00		72-73/ 98-99			
Korando 2.9L TD Diesel		04/98 →			8	BW380 (Fibre), 1.80mm 30-026270-20	DW381 21-28404-50/0	EN720 22-26946-01/0
Korando 2.9L TD 4x4 Diesel		04/98 →						
MB-OM 601 29TD	2874	5	76.50	Indirect Injection, SOHC	88-95/ 120- 129			
OM 662.983	2874	5	89.00		88/120			
Korando 3.2L 4x4		06/97 →			9	AE5330 (Fibre), 1.24mm 30-027354-30	CE5330 21-27354-51/0	
M 104.992	3199	6	89.90	Injection, DOHC	162/220			
Korando 3.2L 4x4		12/96 →			10	AE5330 (Fibre), 1.24mm 30-027354-30	CE5330 21-27354-51/0	
Korando Cabrio 3.2L 4x4		01/99 →						
M 104.995	3199	6	89.90	Injection, DOHC	154- 156/ 209- 212			
Musso 2.0L 4x4		10/96 →			11	BZ880 (Fibre) 30-027462-10	DV810 21-27462-50/0	
E20	1998	4	89.90	Injection, DOHC	93/126			
Musso 2.3L Diesel		01/97 →			12	BW370 (Fibre) 30-027217-20	DW370 21-27217-51/0	EM720 22-24895-01/0
OM 601.900	2299	4	89.00		57/77			
OM 601.940	2299	4	89.00	SOHC	57/77			
OM 601.941/OM 601.942/ OM 601.943/OM 601.970	2299	4	89.00		57/77			
Musso 2.3L 4x4		04/03 →			13	BZ890 (Fibre) 30-028037-00	DZ891 21-28037-51/0	
M 111.974	2295	4	90.90		105- 142/ 143/ 193			
M 161.974	2295	4	90.90		110/150			

								
HBS150 ® (22-26009B) M12x1.75x102mm (x10)								 AE5330  JN619  BM370  JN621  BP890, BP900, BP910  JN622
	JC643 ■ 	JN408	JJ192			NJ267 42x55x9mm, NBR NJ014 50x68x9mm, NBR NJ265 82x105x13mm, MVQ		 BW370  HC346  BW380  JJ192  BZ880  JJ498
HBS150 ® (22-26009B) M12x1.75x102mm (x10)								 BZ890  JJ499  JC566  JJ500
HBS150 ® (22-26009B) M12x1.75x102mm (x10)	JD160 ■ (31-027310-00) JD161 ■ 31-027309-10		JJ499 (31-027311-00)	HR819 ■		NB973 45x67x8mm, FPM (50-305910-50) NB974 93x114x13mm, FPM (50-319192-00)		 BZ900  JC566  JJ500
HBS058 ® (22-26069B) M10x1.50x80mm (x4) M10x1.50x115mm (x5) M10x1.50x102mm (x9)	JD158 ■ JD159 ■ 31-024911-00	JN572 [196] 50-026030-00 JN619 [195] 50-026031-00	JJ498 (31-026923-00)	HR757 ■ 24-30672-71/0		NB973 45x67x8mm, FPM (50-305910-50) NB974 93x114x13mm, FPM (50-319192-00)	KK5683 [160]	 JC643  JD158  JD159  JD160  JD161  JD167
	JC566 ■ (x2)	JN245 (50-024586-00)	HC346 ■ = PA349 (33-102290-10) 22x16x2mm			NF387 42x60x10mm, NBR (50-306429-00)	KA606 [13]	 JD167  JD298  JD299  JN245  JN408  JN572
HBS059 ® (22-26006B) M10x1.50x80mm (x5) M10x1.50x115mm (x6) M10x1.50x102mm (x11)	JD298 ■ 31-025171-30 JD299 ■ 31-025172-00	JN621 [196] 50-026033-00 JN622 [195] 50-026032-00	JJ543 (31-026946-00) = KJ779 (33-110670-00)	HR758 ■ 24-30637-45/0		NB973 45x67x8mm, FPM (50-305910-50) NB974 93x114x13mm, FPM (50-319192-00)		 JC643  JD158  JD159  JD160  JD161  JD167
HBS059 ® (22-26006B) M10x1.50x80mm (x5) M10x1.50x115mm (x6) M10x1.50x102mm (x11)	JD298 ■ 31-025171-30 JD299 ■ 31-025172-00	JN621 [196] 50-026033-00 JN622 [195] 50-026032-00	JJ543 (31-026946-00)	HR758 ■ 24-30637-45/0		NB973 45x67x8mm, FPM (50-305910-50) NB974 93x114x13mm, FPM (50-319192-00)		 JD160  JD161  JD167  JD298  JD299  JN245
HBS152 ® (22-26071B) M12x1.75x160mm (x14)	JD167 ■ 50-027358-00 JD169 ■ (31-026443-10)		JJ500 (31-026394-10)	HR5055 ■ 24-30704-45/0		NB971 45x67x10mm, FPM (50-305913-50) NB974 93x114x13mm, FPM (50-319192-00)		 JN245  JN408  JN572
HBS152 ® (22-26071B) M12x1.75x160mm (x14)	JD167 ■ 50-027358-00 JD169 ■ (31-026443-10)		JJ500 (31-026394-10)	HR5055 ■ 24-30704-45/0		NB971 45x67x10mm, FPM (50-305913-50) NB974 93x114x13mm, FPM (50-319192-00)	KK5683 [160]	
HBS150 ® (22-26009B) M12x1.75x102mm (x10)								
HBS058 ® (22-26069B) M10x1.50x80mm (x4) M10x1.50x115mm (x5) M10x1.50x102mm (x9)	JD158 ■ JD159 ■ 31-024911-00	JN572 [196] 50-026030-00 JN619 [195] 50-026031-00	JJ498 (31-026923-00)	HR757 ■ 24-30672-71/0		NB973 45x67x8mm, FPM (50-305910-50) NB974 93x114x13mm, FPM (50-319192-00)		
HBS150 ® (22-26009B) M12x1.75x102mm (x10)						NB973 45x67x8mm, FPM (50-305910-50) NB974 93x114x13mm, FPM (50-319192-00)		



KW/PS

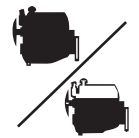

Musso 2.3L 4x4				10/96 →	14	BZ890 (Fibre)		DZ160
M 111.970	2295	4	90.90	Injection, DOHC	103-110/ 140-150	30-028037-00	30-027971-00	21-27971-50/0 DZ891
Musso 2.3L D 4x4 Diesel				10/95 →	15	BW370 (Fibre)		DW370
OM 601.940	2299	4	89.00	SOHC	57-59/ 77-80	30-027217-20		21-27217-51/0
MB-OM 661	2299	4	89.00	Indirect Injection	59/80			EM720 22-24895-01/0
Musso 2.9L D 4x4 Diesel				03/96 →	16	BW380 (Fibre), 1.80mm		DW380
MB-OM 662	2874	5	89.00		72-73/ 98-99	30-026270-20		21-26270-52/0 662.911
Musso 2.9L TD 4x4 Diesel				04/98 →	17	BW380 (Fibre), 1.80mm		DW381
MB-OM 601 29TD	2874	5	76.50	Indirect Injection, SOHC	88-95/ 120-129	30-026270-20		21-28404-50/0
OM 662.983	2874	5	89.00		88/120			EN720 22-26946-01/0
Musso 3.2L 4x4				06/96 →	18	AE5330 (Fibre), 1.24mm		CE5330
M 104.992	3199	6	89.90	Injection, DOHC	162/220	30-027354-30		21-27354-51/0
Rexton 2.9L 4x4 Diesel				04/02 →	19	BW380 (Fibre), 1.80mm		DW381
MB-OM 601 29TD	2874	5	76.50	Indirect Injection, SOHC	88-95/ 120-129	30-026270-20		21-28404-50/0
OM 662.983	2874	5	89.00		88/120			EN720 22-26946-01/0
Rexton 3.2L 4x4				04/02 →	20	AE5330 (Fibre), 1.24mm		CE5330
M 104.992	3199	6	89.90	Injection, DOHC	162/220	30-027354-30		21-27354-51/0

HBS150 Ⓢ <i>(22-26009B)</i> M12x1.75x102mm (x10)	JD160 ■ <i>(31-027310-00)</i> JD161 ■ 31-027309-10		JJ499 <i>(31-027311-00)</i>	HR819 ■	▣ NB973 ■ 45x67x8mm, FPM <i>(50-305910-50)</i> ▣ NB974 ■ 93x114x13mm, FPM <i>(50-319192-00)</i>		 AE5330	 JN572
HBS058 Ⓢ <i>(22-26069B)</i> M10x1.50x80mm (x4) M10x1.50x115mm (x5) M10x1.50x102mm (x9)	JD158 ■ JD159 ■ 31-024911-00	JN572 [196] 50-026030-00 JN619 [195] 50-026031-00	JJ498 <i>(31-026923-00)</i>	HR757 ■ 24-30672-71/0	▣ NB973 ■ 45x67x8mm, FPM <i>(50-305910-50)</i> ▣ NB974 ■ 93x114x13mm, FPM <i>(50-319192-00)</i>	KK5683 [160]	 BW370	 JN619
HBS059 Ⓢ <i>(22-26006B)</i> M10x1.50x80mm (x5) M10x1.50x115mm (x6) M10x1.50x102mm (x11)	JD298 ■ 31-025171-30 JD299 ■ 31-025172-00	JN621 [196] 50-026033-00 JN622 [195] 50-026032-00	JJ543 <i>(31-026946-00)</i> = KJ779 <i>(33-110670-00)</i>	HR758 ■ 24-30637-45/0	▣ NB973 ■ 45x67x8mm, FPM <i>(50-305910-50)</i> ▣ NB974 ■ 93x114x13mm, FPM <i>(50-319192-00)</i>		 BZ890	 JN621
HBS059 Ⓢ <i>(22-26006B)</i> M10x1.50x80mm (x5) M10x1.50x115mm (x6) M10x1.50x102mm (x11)	JD298 ■ 31-025171-30 JD299 ■ 31-025172-00	JN621 [196] 50-026033-00 JN622 [195] 50-026032-00	JJ543 <i>(31-026946-00)</i>	HR758 ■ 24-30637-45/0	▣ NB973 ■ 45x67x8mm, FPM <i>(50-305910-50)</i> ▣ NB974 ■ 93x114x13mm, FPM <i>(50-319192-00)</i>		 BZ900	 JN622
HBS152 Ⓢ <i>(22-26071B)</i> M12x1.75x160mm (x14)	JD167 ■ 50-027358-00 JD169 ■ <i>(31-026443-10)</i>		JJ500 <i>(31-026394-10)</i>	HR5055 ■ 24-30704-45/0	▣ NB971 ■ 45x67x10mm, FPM <i>(50-305913-50)</i> ▣ NB974 ■ 93x114x13mm, FPM <i>(50-319192-00)</i>	KK5683 [160]	 JD158	 JJ498
HBS059 Ⓢ <i>(22-26006B)</i> M10x1.50x80mm (x5) M10x1.50x115mm (x6) M10x1.50x102mm (x11)	JD298 ■ 31-025171-30 JD299 ■ 31-025172-00	JN621 50-026033-00 JN622 50-026032-00	JJ543 <i>(31-026946-00)</i>	HR758 ■ 24-30637-45/0	▣ NB973 ■ 45x67x8mm, FPM <i>(50-305910-50)</i> ▣ NB974 ■ 93x114x13mm, FPM <i>(50-319192-00)</i>		 JD159	 JJ499
HBS152 Ⓢ <i>(22-26071B)</i> M12x1.75x160mm (x14)	JD167 ■ 50-027358-00 JD169 ■ <i>(31-026443-10)</i>		JJ500 <i>(31-026394-10)</i>	HR5055 ■ 24-30704-45/0	▣ NB971 ■ 45x67x10mm, FPM <i>(50-305913-50)</i> ▣ NB974 ■ 93x114x13mm, FPM <i>(50-319192-00)</i>		 JD160	 JJ500
							 JD161	 JJ499
							 JD167	 JJ500
							 JD298	 JJ543
							 JD299	 JJ543



CC



9



CC



9

EA65	Petrol	1298	4	83.00	38
EA81	Petrol	1782	4	92.00	26
EA81	Petrol	1782	4	92.00	47
EA82	Petrol	1782	4	92.00	39
EA82	Petrol	1782	4	92.00	40
EA82	Petrol	1782	4	92.00	42
EA82	Petrol	1782	4	92.00	43
EA82	Petrol	1782	4	92.00	44
EA82	Petrol	1782	4	92.00	61
EA82T	Petrol	1782	4	92.00	1
EA82T	Petrol	1782	4	92.00	2
EF10	Petrol	997	3	78.00	20
EF10	Petrol	997	3	78.00	21
EF10	Petrol	997	3	78.00	22
EF10	Petrol	997	3	78.00	45
EF12	Petrol	1189	3	78.00	23
EF12	Petrol	1189	3	78.00	46
EF12	Petrol	1189	3	78.00	56
EG33 DOHC	Petrol	3319	6		57
EJ16	Petrol	1597	4	87.90	10
EJ16	Petrol	1597	4	87.90	25
EJ16	Petrol	1597	4	87.90	7
EJ18	Petrol	1820	4	87.90	11
EJ18 SPI	Petrol	1820	4		27
EJ18E	Petrol	1820	4	87.90	11
EJ20	Petrol	1994	4	92.00	12
EJ20	Petrol	1994	4	92.00	14
EJ20	Petrol	1994	4	92.00	28
EJ20	Petrol	1994	4	92.00	3
EJ20	Petrol	1994	4	92.00	31
EJ20	Petrol	1994	4	92.00	4
EJ20 (Turbo)	Petrol	1994	4		15
EJ20 EMPI	Petrol	1994	4		30
EJ205	Petrol	1994	4	92.00	17
EJ205	Petrol	1994	4	92.00	18
EJ205	Petrol	1994	4	92.00	5
EJ205P	Petrol	1994	4	92.00	13
EJ205P	Petrol	1994	4	92.00	29
EJ20E	Petrol	1994	4	92.00	30
EJ20G	Petrol	1994	4	92.00	19
EJ20-GN	Petrol	1994	4		32
EJ22 EMPI	Petrol	2212	4	96.90	33
EJ22 EMPI	Petrol	2212	4	96.90	34
EJ25	Petrol	2457	4	99.50	35
EJ25	Petrol	2457	4	99.50	48
EJ25	Petrol	2457	4	99.50	6
EJ25D	Petrol	2457	4	99.50	36
EJ25D	Petrol	2457	4	99.50	49
EK23	Petrol	544	2	76.00	52
EK23	Petrol	544	2	76.00	53
EK23	Petrol	544	2	76.00	58
EK23 6V	Petrol	544	2	76.00	52
EK23 Super Charger	Petrol	544	2	76.00	53
EK42	Petrol	655	2	78.00	55
EN07 Super Charger	Petrol	658	4		54
EN07E	Petrol	658	4	56.00	54
EN07E	Petrol	658	4	56.00	59
EN07E	Petrol	658	4	56.00	60
EZ30	Petrol	3000	6	89.20	37
EZ30	Petrol	3000	6	89.20	50
G13BB	Petrol	1298	4	74.00	24



KW/PS

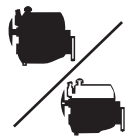

1800 1.8L Turbo						01/85 →	1	BN560 (Graphite) (x2)	DN560	GN560
1800 1.8L Turbo 4WD						01/85 →		(30-028211-00)	08/85 → 12/87	08/85 → 12/87
EA82T	1782	4	92.00					DN561	GN561	
								01/88 →	01/88 →	
Alcyone 1.8L Turbo 4WD						06/85 →	2	BN560 (Graphite) (x2)	DN560	GN560
								(30-028211-00)	08/85 → 12/87	08/85 → 12/87
EA82T	1782	4	92.00					DN561	GN561	
								01/88 →	01/88 →	
Forester 2.0L						08/97 → 09/02	3	AG5580 (MLS) (x2)	CG5580	
								06/02 →		
EJ20	1994	4	92.00	Injection, SOHC	92/125					
Forester 2.0L S Turbo						06/98 → 04/01	4	AG5580 (MLS) (x2)	CG5581	FG5581
								EJ205	EJ205	
EJ20	1994	4	92.00	Injection, SOHC	92/125					
Forester 2.0L S Turbo						04/01 → 09/02	5	AG5580 (MLS) (x2)	CG5582	
								EJ205		
EJ205	1994	4	92.00	Injection, DOHC, Boxer	160-125/218-170					
Forester 2.5L						12/03 →	6	AG6150 (MLS)	CG6150	
EJ25	2457	4	99.50	Injection	115-155/156-211					
Impreza 1.6L						12/00 →	7	AG5590 (MLS) (x2)	CG5590	FG5590
								→ 12/03	→ 12/03	
EJ16	1597	4	87.90	Injection, SOHC	70/95			EJ161	EJ161	
Impreza 1.6L						12/96 → 12/00	8	AG5280 (Fibre), 1.6mm (x2)		EG5280
	1597	4			66/90					
Impreza 1.6L i						06/98 → 12/00	9	AG5590 (MLS) (x2)	CG5590	FG5590
Impreza 1.6L i 4WD						06/98 → 12/00		01/99 →	01/99 →	
								EJ161	EJ161	
	1597	4			70/95					
Impreza 1.6L i						08/92 → 12/00	10	AG5280 (Fibre), 1.6mm (x2)		EG5280
Impreza 1.6L i 4WD						08/92 → 12/00				FG5590
EJ16	1597	4	87.90	Injection, SOHC	70/95					
Impreza 1.8L i 4WD						08/92 → 12/00	11	AG5280 (Fibre), 1.6mm (x2)		EG5280
EJ18	1820	4	87.90	Injection, SOHC	76/103					
EJ18E	1820	4	87.90	Injection, SOHC						
Impreza 2.0L						12/00 →	12	AG5580 (MLS) (x2)	CG5580	
Impreza 2.0L 16V						06/98 → 12/00		→ 12/03		
Impreza 2.0L 4WD						12/95 → 12/00				
Impreza 2.0L i 4WD						10/95 → 12/00				
Impreza Coupe 2.0L 4WD						12/95 → 12/00				
EJ20	1994	4	92.00	Injection, SOHC	92/125					
Impreza 2.0L AWD						09/98 → 09/00	13		CG5582	
Impreza Coupe 2.0L AWD						09/98 → 09/00				
EJ205P	1994	4	92.00	Injection, DOHC, Boxer						
Impreza 2.0L i 4WD						06/98 → 12/00	14	AG5580 (MLS) (x2)	CG5580	FG5581
								EJ202		
EJ20	1994	4	92.00	Injection, SOHC	92/125					
Impreza 2.0L i Turbo 4WD						03/94 → 12/00	15	AG5210 (Fibre), 1.6mm (x2)	CG5440	EG5280
Impreza 2.0L Turbo GT 4WD						03/94 → 12/00				
EJ20 (Turbo)	1994	4		Injection	155/211					
Impreza 2.0L Turbo						12/00 →	16	AG5580 (MLS) (x2)	CG5581	FG5581
Impreza 2.0L WRX Turbo						12/02 →				
	1994	4			160/218					
	1994	4			165/225					

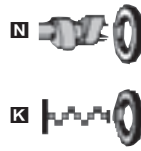
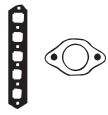

BN560









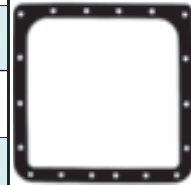

JN610



JN611



JJ360

		JN611  (50-028221-00) JN610  (50-028220-00)	JJ360			
		JN611  (50-028221-00) JN610  (50-028220-00)	JJ360			
HBS405 (22-79005B)	JD5783 					
HBS405 (22-79005B)	JD5783 					
HBS218  (22-79002B) M11x1.25x190mm (x12)	JD5783 	HM5254 				
HBS405 (22-79005B)						
HBS405 (22-79005B)						
HBS218  (22-79002B) M11x1.25x190mm (x12)	JD5767 		JH5101			
HBS405 (22-79005B)						
HBS218  (22-79002B) M11x1.25x190mm (x12)	JD5767 		JH5101			
HBS218  (22-79002B) M11x1.25x190mm (x12)	JD5767 		JH5101			
HBS405 (22-79005B)	JD5783 					
		HM5254 				
HBS405 (22-79005B) 01/95→						
HBS218  (22-79002B) M11x1.25x190mm (x12)	JD5768  JD5783 	HM5234   HM5233  	JH5101			
	JD5783 					

SUBARU



KWPS

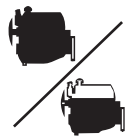

Model						Year Range	Power (kW/PS)	Engine Type	Accessories	
Impreza 2.0L Turbo GT						06/98 → 12/00	17	AG5210 (Fibre), 1.6mm (x2)	CG5440	EG5280
EJ205	1994	4	92.00	Injection, DOHC, Boxer	160-125/218-170					
Impreza 2.0L WRX Turbo						12/00 →	18	AG5580 (MLS) (x2)	CG5581	FG5581
EJ205	1994	4	92.00	Injection, DOHC, Boxer	160-125/218-170					
Impreza Coupe 2.0L Turbo 4WD						12/96 → 12/00	19	AG5210 (Fibre), 1.6mm (x2)	CG5440	EG5280
EJ206	1994	4	92.00	DOHC, Boxer	147/200					
J10 1000						10/83 →	20	BP730 (Graphite)	DP730	GP730
EF10	1997	3	78.00	SOHC	37-41/50-56			→06/85	→06/85	
Justy 1000						11/84 → 06/89	21	BP730 (Graphite)	DP730	GP730
Justy 1000 4WD						11/84 → 11/94			→06/85	→06/85
EF10	1997	3	78.00	SOHC	37-41/50-56			07/85 →	07/85 →	
Justy 1000						05/87 → 10/95	22	BP730 (Graphite)	DP731	GP731
EF10	1997	3	78.00	SOHC	37-41/50-56					
Justy 1200						05/87 → 10/95	23	BR560 (Graphite)	DR560	GR560
Justy 1200 4WD						10/86 → 12/94		(30-028206-00)	→12/86	→12/86
EF12	1189	3	78.00		49/67			DR561	GR561	
								(21-28206-21/0)	(20-28206-01/0)	
								01/87 →	01/87 →	
Justy 1.3L 4x4						04/01 → 11/03	24			EG5220
G13BB	1298	4	74.00	SOHC	62-63/84-86					
Legacy 1.6L GL Mk I						05/89 → 12/93	25			FG5590
Legacy 1.6L Mk I						05/89 → 12/93				
EJ16	1597	4	87.90	Injection, SOHC	70/95					
Legacy 1.8L GL Mk II						08/86 → 07/89	26	BG740 (Graphite)		
EA81	1782	4	92.00		59-60/80-82		(30-028209-00)			
Legacy 1800						01/89 → 07/94	27	AG5280 (Fibre), 1.6mm (x2)		EG5280
Legacy 1800 4WD						01/89 → 07/94				
EJ18 SPI	1820	4		Injection	76/103					
Legacy 2.0L						12/98 → 08/03	28	AG5580 (MLS) (x2)	CG5580	
EJ20	1994	4	92.00	Injection, SOHC	92/125		EJ202			
Legacy 2.0L AWD Mk III						06/02 → 08/03	29		CG5582	
EJ205P	1994	4	92.00	Injection, DOHC, Boxer						
Legacy 2.0L i						09/94 → 03/99	30	AG5290 (Fibre), 1.6mm (x2)	CG5450	EG5280
Legacy 2000						09/91 → 12/93				
Legacy 2000 4WD						08/91 → 07/94				
EJ20 EMPI	1994	4		Injection	85/116					
EJ20E	1994	4	92.00	Injection, SOHC	103-85/140-116					
Legacy 2.0L i 4WD						09/94 → 03/99	31	AG5580 (MLS) (x2)	CG5580	
EJ20	1994	4	92.00	Injection, SOHC	92/125		→12/03			
Legacy 2000 Turbo 4WD						05/92 → 07/94	32	AG5210 (Fibre), 1.6mm (x2)	DV544	EG5280
Legacy 2000 Turbo Super 4WD						05/92 → 07/94				
EJ20-GN	1994	4		Injection, DOHC	147/200					

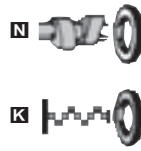
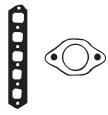

BG740



BP730



BR560



JC967



JN656

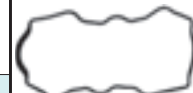

JN681

	JD5768 JD5783	HM5254 HM5234 HM5233	JH5101			
	JD5783	HM5254				
HBS405 (22-79005B)	JD5768 JD5783	HM5234 HM5233	JH5101			
		JN681			NK243 68x84x8.5mm, FPM	
		JN681			NK243 68x84x8.5mm, FPM	
		JN681			NK243 68x84x8.5mm, FPM	
	JC967	JN656 (50-028217-00)	JJ389	PA656 (x3) PA655 (x3)	NJ846 38.5x53x8mm, NBR NK243 68x84x8.5mm, FPM	KA725 [13]
HBS218 (22-79002B) M11x1.25x190mm (x12)	JD5767		JH5101			
HBS405 (22-79005B)	JD5767		JH5101			
		HM5254				
HBS218 (22-79002B) M11x1.25x190mm (x12) HBS405 (22-79005B) 01/95→	JD5767		JH5101			
HBS405 (22-79005B)	JD5783					
HBS405 (22-79005B)	JD5768 JD5783	HM5256 HM5255	JH5101			



KW/PS



Model						Year Range	Power (kW/PS)	Configuration	Engine Code	Accessories
Legacy 2.2L i 4WD						09/94 → 03/99	33			
EJ22 EMPI	2212	4	96.90	Injection, SOHC	94-100/ 128- 136	BV450 (Graphite) (x2)	DV543	EG5280		
Legacy 2200 4WD						01/89 → 07/94	34			
Legacy 2200 Super 4WD						01/89 → 07/94				
EJ22 EMPI	2212	4	96.90	Injection, SOHC	94-100/ 128- 136	BV450 (Graphite) (x2)	DV450	EG5280		
Legacy 2.5L Mk IV						09/03 →	35			
Legacy 2.5L						10/98 → 08/03				
EJ25	2457	4	99.50	Injection	115- 155/ 156- 211	AG6150 (MLS)	CG6150			
Legacy 2.5L i 4WD						06/96 → 03/99	36			
EJ25D	2457	4	99.50	DOHC	110/150		CG6151	EG5280		
Legacy 3.0L Mk IV						09/03 →	37			
EZ30	3000	6	89.20	DOHC, Boxer	180/245	AG5600 (MLS)	CG5600	FG5600		
Leone 1300						03/79 → 09/91	38			
EA65	1298	4	83.00	OHV	45-48/ 61-65	BM340 (Fibre) (x2)				
Leone 1800 4WD						11/84 → 07/91	39			
EA82	1782	4	92.00		100/136	BN550 (Graphite) (x2)	DN550 →12/85 DN551 01/86 → 12/87 DN552 01/88 →	GN551 01/86 → 12/87 GN552 01/88 →		
Leone 1800 4WD						01/88 → 12/90	40			
EA82	1782	4	92.00		100/136	BN550 (Graphite) (x2)	DN552	GN552		
Leone 1800 4WD						07/86 → 09/91	41			
Leone 1800 Super 4WD						07/86 → 02/92				
	1781	4			70/95	BN560 (Graphite) (x2) (30-028211-00)	DN561			
Leone 1800 Super 4WD						03/89 → 12/90	42			
EA82	1782	4	92.00		100/136	BN550 (Graphite) (x2) BN560 (Graphite) (x2) (30-028211-00)	DN561			
Leone 1800 Super Turbo 4WD						11/84 → 12/90	43			
Leone 1800 Turbo 4WD						11/84 → 12/90				
EA82	1782	4	92.00		100/136	BN550 (Graphite) (x2) BN560 (Graphite) (x2) (30-028211-00)	DN560 →12/87 DN561 01/88 →	GN560 →12/87 GN561 01/88 →		
Leone 1800 Turbo 4WD						03/89 → 12/90	44			
EA82	1782	4	92.00		100/136	BN550 (Graphite) (x2) BN560 (Graphite) (x2) (30-028211-00)	DN561	GN561		
Libero 1.0L 4WD						01/83 → 12/87	45			
EF10	997	3	78.00	SOHC	37-41/ 50-56	BP730 (Graphite) 07/85 →	DP730 DP731 07/85 →	GP730 GP731 07/85 →		
Libero 1.2L 4WD						08/86 → 02/00	46			
Libero 1.2L i 4WD						08/91 → 02/00				
EF12	1189	3	78.00		49/67	BR560 (Graphite) (30-028206-00)	DR561 (21-28206-21/0)	GR561 (20-28206-01/0)		
MV 1.8L						05/81 → 08/86	47			
EA81	1782	4	92.00		59-60/ 80-82	BG740 (Graphite) (x2) (30-028209-00)				

HBS218 ⊙ (22-79002B) M11x1.25x190mm (x12)	JD5767 ■ JD5783 ■		JH5101						
HBS218 ⊙ (22-79002B) M11x1.25x190mm (x12)	JD5767 ■ JD5783 ■		JH5101						
HBS405 (22-79005B)	JD5768 ■ JD5783 ■		JH5101						
HBS405 (22-79005B)	JD5768 ■ JD5783 ■		JH5101						
	JC140 ■ (x2)	JM065 (x2)	JH050	KJ462 (x4)	<input checked="" type="checkbox"/> NJ022 ■ 38x55x9mm, FPM/ACM <input checked="" type="checkbox"/> NJ342 ■ 70x87x8.5mm, MVQ				
	JC595 ■ (x2)	JN611 ■ (50-028221-00) JN610 ■ (50-028220-00) HL478 ■	JJ360	PA656 ■ (x4) PA655 ■ (x4)	<input checked="" type="checkbox"/> NJ022 (x2) 38x55x9mm, FPM/ACM <input checked="" type="checkbox"/> NJ341 ■ 38x59x9mm, NBR <input checked="" type="checkbox"/> NJ343 ■ 76x93x10mm, MVQ				
	JC595 ■ (x2)	JN611 ■ (50-028221-00) JN610 ■ (50-028220-00) HL478 ■	JJ360	PA656 ■ (x4) PA655 ■ (x4)	<input checked="" type="checkbox"/> NJ022 (x2) 38x55x9mm, FPM/ACM <input checked="" type="checkbox"/> NJ341 ■ 38x59x9mm, NBR <input checked="" type="checkbox"/> NJ343 ■ 76x93x10mm, MVQ				
		JN611 ■ (50-028221-00) JN610 ■ (50-028220-00)	JJ360						
		JN611 ■ (50-028221-00) JN610 ■ (50-028220-00)	JJ360						
		JN681 07/85 →			<input checked="" type="checkbox"/> NK243 ■ 68x84x8.5mm, FPM				
	JC967 ■ JC700 ■	JN656 (50-028217-00)	JJ389	PA656 ■ (x3) PA655 ■ (x3)	<input checked="" type="checkbox"/> NJ846 38.5x53x8mm, NBR <input checked="" type="checkbox"/> NK243 ■ 68x84x8.5mm, FPM		KA725 [13]		



KW/PS

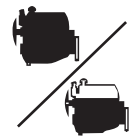

Model					Year Range	Power (KW/PS)	Engine	Code	Accessories
Outback 2.5L					10/00 → 08/03	48		CG6150	
EJ25	2457	4	99.50	Injection	115-155/156-211				
Outback 2.5L					11/03 →	49	AG5200 (Fibre), 1.6mm	CG5430	
EJ25D	2457	4	99.50	DOHC	110/150				
Outback 3.0L					11/03 →	50	AG5600 (MLS)	CG5600	FG5600
EZ30	3000	6	89.20	DOHC, Boxer	180/245	EZ30D AG5610 (MLS)			
Outback 3.0L H6					10/00 → 08/03	51	AG5600 (MLS)		
	3000	6			154/209	EZ30D AG5610 (MLS)			
REX 550					08/81 → 06/89	52	BL280 (Graphite)	DL280	GL280 [225] GL281 [130] [20-28204-01/0]
EK23	544	2	76.00		23/31	[30-028204-00]	[21-28204-20/0]		
EK23 6V	544	2	76.00	Injection	26/35				
REX 550					08/83 → 06/87	53	BL280 (Graphite)	DL280	
REX 550 Kompressor					08/88 → 06/89		[30-028204-00]	[21-28204-20/0]	
REX 550 Turbo					07/84 → 06/87				
EK23	544	2			30/41				
EK23 Super Charger	544	2	76.00		23/31				
EK23 Super Charger	544	2	76.00		40/54				
REX 0.7L					07/90 → 03/92	54	AG7980 (Graphite)	CG7980	FG7980
REX 0.7L 4WD					07/90 → 03/92				
REX 0.7L Kompressor 4WD					07/90 → 02/92				
EN07 Super Charger	658	4			47/64				
EN07E	658	4	56.00	MPI, SOHC	32-35/44-48				
REX 700					08/82 → 06/89	55	BL280 (Graphite)	DL280	
EK42	655	2	78.00		27/37	[30-028204-00]	[21-28204-20/0]		
Sumo 1.2L					01/90 → 12/97	56	BR560 (Graphite)	DR560	GR560
EF12	1189	3	78.00		49/67	[30-028206-00]	10/85 → DR561 [21-28206-21/0] 01/87 →	10/85 → GR561 [20-28206-01/0] 01/87 →	
SVX Coupe 3.3L i 24V 4WD					09/92 → 12/97	57	AF5760 (Graphite) (x2)	CF5760	FF5760
EG33 DOHC	3319	6		Injection, DOHC, Boxer	162-169/220-230	EG33			
Van 600					08/82 → 06/87	58	BL280 (Graphite)	DL280	GL280 [225] GL281 [130] [20-28204-01/0]
EK23	544	2	76.00		23/31	[30-028204-00]	[21-28204-20/0]		
Vivio 0.7L					08/92 → 12/98	59	AG7980 (Graphite)	CG7980	FG7980
EN07E	658	4	56.00	MPI, SOHC	32-35/44-48				
Vivio 660 4WD					03/92 → 10/95	60	AG7980 (Graphite)	CG7980	FG7980
EN07E	658	4	56.00	MPI, SOHC	32-35/44-48	EN07C			
XT Coupe 1.8L Turbo 4WD					11/84 → 12/90	61	BN550 (Graphite) (x2) BN560 (Graphite) (x2) [30-028211-00]	DN560 → 12/87 DN561 01/88 →	GN560 → 12/87 GN561 01/88 →
EA82	1782	4	92.00		100/136				

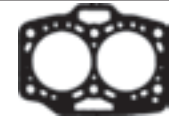
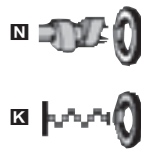
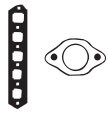

BL280



BN550



BN560



BR560



JC595



JC700



JC967



JN610



JN611



JN656



JN729

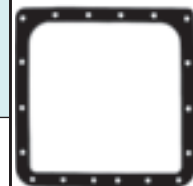

JJ360

	JD5768	HM5232						
	JD5783	HM5231						
		JN729 [225]						
		HM5257						
	JC967	JN656 (50-028217-00)	JJ389	PA655 (x3) PA656 (x3)			KA725 [13]	
	JC700	HM5253						
		(ACM) EG33						
		HM5252						
		(ACM) EG33						
		JN729 [225]						
		HM5257						
		HM5257						
	JC595 (x2)	JN611	JJ360	PA656 (x4) PA655 (x4)				
		(50-028221-00)						
		JN610						
		(50-028220-00)						



CC



9



CC



9

8HY	Diesel	1398	4	73.70	38
AB51	Petrol	796	3	68.50	3
DW10ATED4 (RHW)	Diesel	1997	4	85.00	26
F10A	Petrol	970	4	65.50	41
F10A	Petrol	970	4	65.50	46
F10A	Petrol	970	4	65.50	48
F5A	Petrol	543	2	62.00	1
F5A	Petrol	543	2	62.00	13
F5A	Petrol	543	2	62.00	20
F8A	Petrol	797	4	62.00	14
F8A	Petrol	797	4	62.00	21
F8A	Petrol	797	4	62.00	39
F8B	Petrol	796	3	68.50	2
G10	Petrol	993	3	74.00	49
G10A	Petrol	993	3	74.00	49
G10A	Petrol	993	3	74.00	50
G10B	Petrol	993	4	72.00	4
G10B	Petrol	993	4	72.00	5
G10T	Diesel	993	3	74.00	51
G13A	Petrol	1324	4	74.00	17
G13A	Petrol	1324	4	74.00	36
G13A	Petrol	1324	4	74.00	43
G13A	Petrol	1324	4	74.00	44
G13A	Petrol	1324	4	74.00	47
G13A	Petrol	1324	4	74.00	54
G13A	Petrol	1324	4	74.00	55
G13B	Petrol	1298	4	74.00	16
G13B	Petrol	1298	4	74.00	18
G13B	Petrol	1298	4	74.00	40
G13B	Petrol	1298	4	74.00	57
G13B	Petrol	1298	4	74.00	58
G13B	Petrol	1298	4	74.00	8
G13BA	Petrol	1298	4	74.00	42
G13BA	Petrol	1298	4	74.00	8
G13BB	Petrol	1299	4	74.00	15
G13BB	Petrol	1299	4	74.00	23
G13BB	Petrol	1299	4	74.00	33
G13BB	Petrol	1299	4	74.00	53
G13BB	Petrol	1299	4	74.00	6
G13BB	Petrol	1299	4	74.00	73
G13BB	Petrol	1299	4	74.00	9
G16A	Petrol	1590	4	75.00	19
G16A	Petrol	1590	4	75.00	60
G16A	Petrol	1590	4	75.00	62
G16B	Petrol	1590	4	75.00	10
G16B	Petrol	1590	4	75.00	24
G16B	Petrol	1590	4	75.00	59
G16B	Petrol	1590	4	75.00	63
G16B	Petrol	1590	4	75.00	7
G16B	Petrol	1590	4	75.00	76
H 25 A	Petrol	2493	6	84.00	28
H 27 A	Petrol	2736	6	88.00	29
H20A	Petrol	1998	6	78.00	68
J18A	Petrol	1839	4	84.00	11
J20A	Petrol	1995	4	84.00	25
J20A	Petrol	1995	4	84.00	61
J20A	Petrol	1995	4	84.00	66
M13A	Petrol	1328	4	78.00	22
M13A	Petrol	1328	4	78.00	30
M13A	Petrol	1328	4	78.00	34
M13A	Petrol	1328	4	78.00	35
M13A	Petrol	1328	4	78.00	37
M13A	Petrol	1328	4	78.00	52
M13A	Petrol	1328	4	78.00	74
RF	Diesel	1998	4	86.00	27
RF	Diesel	1998	4	86.00	67
XUD9	Diesel	1905	4	83.00	45
XUD9A	Diesel	1905	4	83.00	64
XUD9SD	Diesel	1905	4	83.00	12

XUD9SD	Diesel	1905	4	83.00	64
XUD9TF/BTF (DHX)	Diesel	1905	4	83.00	65
Z 12 XEP	Petrol	1229	4	73.40	72
Z13DT	Diesel	1248	4	82.00	31
Z13DT	Diesel	1248	4	82.00	56
Z13DT	Diesel	1248	4	82.00	75



KW/PS

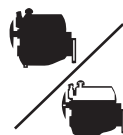

Alto 550 Van		01/79 → 12/90			1	BH740 (Fibre) (30-028120-00) →12/84 BP780 (Fibre) 01/85 →	DH740 →12/84	GH740 (20-28120-00/0) →12/84			
F5A	543	2	62.00	Injection	22/30						
Alto 0.8L		01/86 → 11/93			2		DM911 (21-28126-21/0)				
F8B	796	3	68.50	Injection	29/39						
Alto 0.8L		11/83 → 12/85			3	BM910 (Graphite) (30-028126-00)	DM910 (21-28126-20/0) →12/85 DM911 [242] (21-28126-21/0) 01/86 → DM912 ■ Europe 01/86 →	GM910 →12/85 GM911 [242] 01/86 → GM912 Europe 01/86 →			
Alto 0.8L Europe		01/86 →									
AB51	796	3	68.50	SOHC							
Alto 1.0L		01/00 →			4		DT900 (21-28123-20/0)				
G10B	993	4	72.00	MPi, SOHC	39-43/ 53-58						
Alto 1.0L		09/94 → 06/02			5		DT900 (21-28123-20/0)				
G10B	993	4	72.00	MPi, SOHC	39-43/ 53-58						
Alto 1.3L Mk III		10/98 → 09/00			6	BN480 (Graphite) (30-028124-00)	CG5480	EG5220			
G13BB	1299	4	74.00	MPi, SOHC	56-63/ 76-86						
Alto 1.6L Mk III		10/98 → 09/00			7	AG5260 (Fibre), 1.2mm	CG5511	EG5260			
G16B	1590	4	75.00	MPi, SOHC	68-72/ 92-98						
Baleno 1.3L		09/96 → 05/02			8	BN480 (Graphite) (30-028124-00)	CG5480				
Baleno 1.3L i 16V		07/95 → 05/02									
G13B	1298	4	74.00	DOHC	44-74/ 60-101						
G13BA	1298	4	74.00	SPi	51-52/ 70-71						
Baleno 1.3L 16V		03/97 → 05/02			9	BN480 (Graphite) (30-028124-00)	CG5480	EG5220			
G13BB	1299	4	74.00	MPi, SOHC	56-63/ 76-86						
Baleno 1.6L i 16V		07/95 → 05/02			10	AG5260 (Fibre), 1.2mm	CG5511	EG5260			
Baleno 1.6L i 16V 4x4		07/95 → 05/02									
G16B	1590	4	75.00	MPi, SOHC	68-72/ 92-98						
Baleno 1.8L GT		03/96 → 05/02			11	AG8020 (MLS)	CG8020				
Baleno 1.8L i 16V		08/96 → 05/02									
J18A	1839	4	84.00	Injection	89/121						
Baleno 1.9L TD Diesel		04/98 → 05/02			12	BX930 (Steel Elastomer), 1.36mm, 1 Notch (30-028503-00) BX940 (Steel Elastomer), 1.40mm, 2 Notches (30-028504-00) BX950 (Steel Elastomer), 1.44mm, 3 Notches (30-028505-00) BX960 (Steel Elastomer), 1.48mm, 4 Notches (30-028506-00) BX970 (Steel Elastomer), 1.52mm, 5 Notches (30-028507-00)	DJ720▲ (21-25202-22/0)	EL890 (22-25198-01/0) GJ720▲ (20-25202-02/0)			
XUD9SD	1905	4	83.00	SOHC, Turbo	55/75						
Carry 0.5L		01/79 → 12/90			13				BH740 (Fibre) (30-028120-00) →12/84 BP780 (Fibre) 01/85 →	DH740 →12/84	GH740 (20-28120-00/0) →12/84
Carry Van 0.5L		01/79 → 12/90									
F5A	543	2	62.00	Injection	22/30						

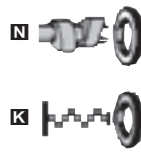
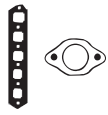

BH740



BM910



BN480



BP780

BX930, BX940,
BX950, BX960,
BX970

JC242



JC991



JN440



JN544



JN854



JJ187



JJ283

	JC242E	JN440 12/85→	JJ187	KJ502 (50-305260-00) PA305 (x6)	<input checked="" type="checkbox"/> NJ336F 32x47x8mm, NBR <input checked="" type="checkbox"/> NJ336E 32x47x8mm, NBR <input checked="" type="checkbox"/> NJ337E 60x80x8mm, NBR	
		JN854				
	JC242E	JN440	JJ187	PA305 (x6)	<input checked="" type="checkbox"/> NJ336 32x47x8mm, NBR <input checked="" type="checkbox"/> NJ336F 32x47x8mm, NBR <input checked="" type="checkbox"/> NJ337E 60x80x8mm, NBR	
			JJ341			
			JJ341	PA096 (x8) [117]		
	JD5770E JD5769E	JN886	JJ341			
	JD5770E JD5769E	JN886	JJ341			
	JD5770E JD5769E	JN886	JJ341			
	JD5770E JD5769E	JN886	JJ341			
	JD5770E JD5769E	JN886	JJ341			
		JM5304 01/97→ G18				
HBS088 ® (22-15014B) M12x1.50x145mm (x10) →Eng.08574 HBS277 ® (22-53018B) M12x1.50x148mm (x10) Eng.08575→	JC991 (31-028595-00)	JN544 (50-025202-00)	JJ283 [6] (31-025198-10)	HR569E 24-30667-00/0	<input checked="" type="checkbox"/> NF841 35x50x8mm, FPM (50-319310-00) <input checked="" type="checkbox"/> NA5191E 42x62x7mm, PTFE (50-319500-00) <input checked="" type="checkbox"/> NA5192E 90x110x7mm, PTFE (50-319501-00)	HL5010 [245]E
	JC242E	JN440 12/85→	JJ187	KJ502 (50-305260-00) PA305 (x6)	<input checked="" type="checkbox"/> NJ336F 32x47x8mm, NBR <input checked="" type="checkbox"/> NJ336E 32x47x8mm, NBR <input checked="" type="checkbox"/> NJ337E 60x80x8mm, NBR	



KW/PS

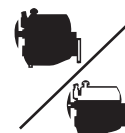

Carry Van 0.8L						11/80 → 10/85	14	BE550 (Graphite)	DE550	GE550
F8A	797	4	62.00		27-29/ 37-39					
Carry 1.3L 4x4						02/99 → 09/04	15	BN480 (Graphite)	CG5480	EG5220
Carry Van 1.3L 16 V						03/00 →		(30-028124-00)		
G13BB	1299	4	74.00	MPi, SOHC	56-63/ 76-86					
Carry Van 1.3L						03/99 →	16	BN480 (Graphite)	CG5480	GN483
G13B	1298	4	74.00	DOHC	44-74/ 60-101		(30-028124-00)			
Cultus 1.3L 4WD						10/84 → 03/89	17	BN480 (Graphite)	DN481	GN481
G13A	1324	4	74.00		44-54/ 60-73		(30-028124-00)	(21-28124-21/0)	(20-28124-02/0)	
Cultus 1.3L GTi 16V						04/87 → 12/88	18	BN480 (Graphite)	DN482	GN482
G13B	1298	4	74.00	DOHC	44-74/ 60-101		(30-028124-00)	(21-28124-22/0)		
Escudo 4WD						07/88 →	19	BS600 (Graphite)	DS600	GS600
G16A	1590	4	75.00	SOHC	50-60/ 68-82			(21-28125-20/0)	(20-28125-00/0)	
Fronte 550						01/79 → 12/90	20	BH740 (Fibre)	DH740	GH740
F5A	543	2	62.00	Injection	22/30		(30-028120-00) → 12/84 BP780 (Fibre) 01/85 →	→ 12/84	(20-28120-00/0) → 12/84	
Gemini 800						01/78 → 12/88	21	BE550 (Graphite)	DE550	GE550
F8A	797	4	62.00		27-29/ 37-39					
Grand Vitara 1.3L						08/06 →	22	AG8180 (MLS)	CG8180	
M13A	1328	4	78.00	Injection	60-69/ 82-94					
Grand Vitara 1.3L						05/05 → 07/06	23	BN480 (Graphite)	CG5480	EG5220
G13BB	1299	4	74.00	MPi, SOHC	56-63/ 76-86		(30-028124-00)			
Grand Vitara 1.6L						03/98 →	24	AG5260 (Fibre), 1.2mm	CG5511	EG5260
G16B	1590	4	75.00	MPi, SOHC	68-72/ 92-98					
Grand Vitara 2.0L Allrad						04/98 → 08/05	25	AG8020 (MLS)	CG8020	
Grand Vitara 2.0L						03/98 →				
J20A	1995	4	84.00	Injection	94-97/ 128- 132					
Grand Vitara 2.0L HDI 110 Diesel						07/01 →	26	AC5011 (MLS), 1.30mm, 1 Hole	CC5010▲	
DW10ATED4 (RHW)	1997	4	85.00	Direct Injection	80/109		☞ 0.47 → 0.605mm AC5031 (MLS), 1.40mm, 3 Holes (30-029479-10) ☞ 0.655 → 0.705mm AC5051 (MLS), 1.50mm, 5 Holes (30-029481-10) ☞ 0.755 → 0.83mm	(21-29484-20/0)		
Grand Vitara 2.0L TD Intercooler Diesel						03/98 →	27	AG5130 (MLS), 1.5mm	CG5460	
RF	1998	4	86.00	OHV	52-68/ 71-92					
Grand Vitara 2.5L V6 24V						04/98 →	28	AG5740 (Graphite) ☒ AG5730 (Graphite) ☒	CG5730	
H 25 A	2493	6	84.00	Injection, DOHC, V6	106- 116/ 144- 158					

		JC420 (x2) JC222 	JN414	JJ163	KJ502 <i>(50-305260-00)</i> PA096 (x8) [117]	NJ336 32x47x8mm, NBR NJ336 32x47x8mm, NBR NJ337 60x80x8mm, NBR	 BE550 BH740 BN480 BP780 BS600 JC222 JC242 JC641 JC867 JC868
		JD5770 JD5769	JN886				 BN480 BP780 BS600 JC222 JC242 JC641 JC867 JC868
		JD5770 JD5769 	JN606 <i>(31-028132-00)</i> JN886		PA305 (x8)	NJ336 32x47x8mm, NBR NJ377 32x47x6mm, ACM NJ378 68x86x8mm, ACM	 BP780 BS600 JC222 JC242 JC641 JC867 JC868
		 	JN606 <i>(31-028132-00)</i> JN886		PA305 (x8)	NJ336 32x47x8mm, NBR NJ377 32x47x6mm, ACM NJ378 68x86x8mm, ACM	 BS600 JC222 JC242 JC641 JC867 JC868
			JN682		PA928 (x16) <i>(50-319454-00)</i>	NJ336 (x2) 32x47x8mm, NBR NJ377 32x47x6mm, ACM NJ378 68x86x8mm, ACM	 JC222 JC242 JC641 JC867 JC868
		JC868 JC867 	JN606 <i>(31-028132-00)</i>		PA305 (x8)	NJ336 32x47x8mm, NBR NJ377 32x47x6mm, ACM NJ378 68x86x8mm, ACM	 JC222 JC242 JC641 JC867 JC868
		JC242	JN440 12/85→	JJ187	KJ502 <i>(50-305260-00)</i> PA305 (x6)	NJ336 32x47x8mm, NBR NJ336 32x47x8mm, NBR NJ337 60x80x8mm, NBR	 JC222 JC242 JC641 JC867 JC868
		JC420 (x2) JC222 	JN414	JJ163	KJ502 <i>(50-305260-00)</i> PA096 (x8) [117]	NJ336 32x47x8mm, NBR NJ337 60x80x8mm, NBR	 JC222 JC242 JC641 JC867 JC868
			JM5312				 JN414 JN440 JN606 JN682 JJ187
		JD5770 JD5769	JN886				 JN414 JN440 JN606 JN682 JJ187
		JD5770 JD5769	JN886	JJ341			 JN414 JN440 JN606 JN682 JJ187
HBS447 <i>(22-73003B)</i>		JM5304					 JN414 JN440 JN606 JN682 JJ187
HBS261 ⊕ <i>(22-53014B)</i> M12x1.50x131mm (x10)	JD5191 JD5190				HR5046	NA5035 27x47x7mm, FPM <i>(50-319474-00)</i> NA5191 42x62x7mm, PTFE <i>(50-319500-00)</i> NA5192 90x110x7mm, PTFE <i>(50-319501-00)</i>	HL5016 [245]
HBS211 ⊙ <i>(22-75001B)</i> M12x1.50x113mm (x10)							
		JM5308 JM5307					



KW/PS

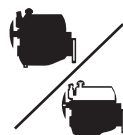

Model						Year Range	Power (KW/PS)	Configuration	Engine Code	Accessories	
Grand Vitara 2.7L V6						09/01 →	29		AG8100 (MLS)	CG8100	FG8100
Grand Vitara 2.7L XL-7						04/03 →			AG8110 (MLS)		
Grand Vitara 2.7L						06/01 →08/03					
H 27 A	2736	6	88.00	DOHC, V6		127-136/ 173-185					
Ignis 1.3L						10/00 →09/03	30		AG8180 (MLS)	CG8180	
Ignis 1.3L 4WD						10/00 →09/03			M13AVT		
Ignis 1.3L 4x4						09/03 →					
M13A	1328	4	78.00	Injection		60-69/ 82-94					
Ignis 1.3L DDiS Diesel						09/03 →	31		AD5800 (MLS), 0.72mm (30-029762-00)	CD5800▲ (21-29762-20/0)	
Z13DT	1248	4	82.00	Direct Injection		51/70		AD5810 (MLS), 0.82mm, 1 Hole (30-029763-00)			
								AD5820 (MLS), 0.92mm, 2 Holes (30-029764-00)			
Jimny 1.0L						09/98 →10/03	32		BM740 (Graphite)	DM740	GT900
	970	4				39/53		→08/88	→08/88	(20-28123-00/0)	
								BT900 (Graphite)	DT900	09/88 →	
								09/88 →	(21-28123-20/0)	09/88 →	
Jimny 1.3L 16V						09/98 →	33		BN480 (Graphite)	CG5480	EG5220
Jimny 1.3L 16V 4WD						09/98 →			(30-028124-00)		
Jimny 1.3L 4WD						09/98 →08/00					
G13BB	1299	4	74.00	MPi, SOHC		56-63/ 76-86					
Jimny 1.3L 16V						02/01 →	34		AG8180 (MLS)	CG8180	
Jimny 1.3L 16V 4WD						02/01 →			M13A		
M13A	1328	4	78.00	Injection		60-69/ 82-94					
Jimny 1.3L 16V 4x4						08/05 →	35		AG8180 (MLS)	CG8180	
Jimny 1.3L 4x4						09/00 →08/02					
M13A	1328	4	78.00	Injection		60-69/ 82-94					
Jimny 1.3L 4WD						10/84 →03/89	36		BN480 (Graphite)	DN481	GN481
G13A	1324	4	74.00			44-54/ 60-73		(30-028124-00)	(21-28124-21/0)	(20-28124-02/0)	
									01/85 →		
Liana 1.3L						03/02 →	37		AG8180 (MLS)	CG8180	
M13A	1328	4	78.00	Injection		60-69/ 82-94					
Liana DDiS Diesel						03/05 →	38			CD5130▲ (21-29277-00/0)	
8HY	1398	4	73.70	Direct Injection		66/89					
LJ 80 0.8L						01/80 →01/84	39		BE550 (Graphite)	DE550	GE550
F8A	797	4	62.00			27-29/ 37-39					
Pickup 1.3L						01/85 →	40		BN480 (Graphite)	DN481	GN481
G13B	1298	4	74.00	DOHC		44-74/ 60-101		(30-028124-00)	(21-28124-21/0)	(20-28124-02/0)	
Samurai 1.0L						11/88 →	41		BL390 (Graphite)	DL391	GL391
F10A	970	4	65.50	SOHC		30-33/ 41-45		(30-028127-00)	(21-28127-21/0)	(20-28127-01/0)	







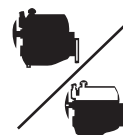



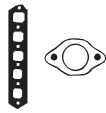

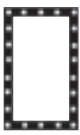

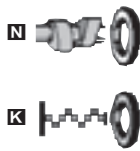



































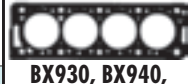















































			JM5308 JM5307										AD5800
			JM5312 M13AWT										AD5810
HBS353 (22-17025B) M10x1.25x119mm (x10)	JD5411 (50-030025-00) JD5412 (50-030026-00) JD5413 (31-030027-00) (MLS)	JM5259 (31-030023-00)		HR5088 (24-31952-10/0)	NA5223 (50-319520-00) NA5230 (50-319522-00)								AD5820
	JC532	JN579 →01/88		PA305 (x6) →01/88 PA096 (x6) [117] 01/88 →	NJ336 32x47x8mm, NBR →08/88 NJ337 60x80x8mm, NBR 09/88 → NJ337 60x80x8mm, NBR NJ378 68x86x8mm, ACM								BE550
	JD5770 JD5769	JN886											BL390
		JM5312 M13A											BM740
		JM5312											BN480
	JC641 JF046 JF109	JN606 (31-028132-00)		PA305 (x8)	NJ336 32x47x8mm, NBR NJ377 32x47x6mm, ACM NJ378 68x86x8mm, ACM								BT900
		JM5312											JC222
HBS359 (22-15018B) M11x1.50x150mm (x10)	HA5029 (24-35042-80/0) JD5829 (31-030265-00)				NA5258 27x47x7mm NA5259 40x55x6.4mm								JC532
	JC420 (x2) JC222 JE735	JN414	JJ163	KJ502 (50-305260-00) PA096 (x8) [117]	NJ336 32x47x8mm, NBR NJ336 32x47x8mm, NBR NJ337 60x80x8mm, NBR								JC641
	JC641 JF109	JN606 (31-028132-00)		PA305 (x8)	NJ336 (x2) 32x47x8mm, NBR NJ377 32x47x6mm, ACM NJ378 68x86x8mm, ACM								JD097
	JD097 JE735	JN414	JJ273	PA305 (x8)	NJ336 32x47x8mm, NBR NJ336 32x47x8mm, NBR NJ337 60x80x8mm, NBR								JD5412
													JN414
													JN579
													JN606
													JJ273



KW/PS

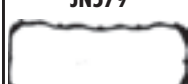

Model						Year Range	Code	Material	Part Number	Notes
Samurai 1.3L						11/88 →	42	BN480 (Graphite)	DN483	
G13BA	1298	4	74.00	SPi		51-52/ 70-71	(30-028124-00) →12/95	→12/94 CG5470 01/95 →		
Samurai 1.3L						11/88 →	43	BN480 (Graphite)	DN481	GN480 ■ GN481 ■
G13A	1324	4	74.00			44-54/ 60-73	(30-028124-00)	(21-28124-21/0)	(20-28124-02/0)	
Samurai 1.3L						10/84 →03/89	44	BN480 (Graphite)	DN480 ■	GN481 ■
G13A	1324	4	74.00			44-54/ 60-73	(30-028124-00)	→12/84 DN481 (21-28124-21/0) 01/85 →	(20-28124-02/0)	
Samurai 1.9L TD Diesel						11/98 →	45	BX930 (Steel Elastomer), 1.36mm, 1 Notch BX940 (Steel Elastomer), 1.40mm, 2 Notches BX950 (Steel Elastomer), 1.44mm, 3 Notches BX960 (Steel Elastomer), 1.48mm, 4 Notches BX970 (Steel Elastomer), 1.52mm, 5 Notches	DJ720▲	EL890 GJ720▲
XUD9	1905	4	83.00			46/55/ 63/75	(30-028503-00) (30-028504-00) (30-028505-00) (30-028506-00) (30-028507-00)	(21-25202-22/0)	(22-25198-01/0) (20-25202-02/0)	
SJ 410 1.0L						09/81 →12/88	46	BL390 (Graphite)	DL390	GL390
SJ 410 Cabrio 1.0L						09/81 →12/88		(30-028127-00)	(21-28127-20/0)	(20-28127-00/0)
F10A	970	4	65.50	SOHC		30-33/ 41-45		→12/85 DL391 (21-28127-21/0) 01/86 →	→12/85 GL391 (20-28127-01/0) 01/86 →	
SJ 413 1.3L						09/84 →08/90	47	BN480 (Graphite)	DN480 ■	GN480 ■
G13A	1324	4	74.00			44-54/ 60-73	(30-028124-00)	→12/84 DN481 (21-28124-21/0) 01/85 →	GN481 ■ (20-28124-02/0)	
Super Carry 1.0L						10/85 →03/99	48	BL390 (Graphite)	DL391	GL391
F10A	970	4	65.50	SOHC		30-33/ 41-45	(30-028127-00)	(21-28127-21/0)	(20-28127-01/0)	
Swift 1.0L						10/83 →03/89	49	BM740 (Graphite)	DM740	GT900
G10	993	3	74.00	Injection, SOHC		37-40/ 50-54	→08/88	→08/88	(20-28123-00/0)	
G10A	993	3	74.00	Injection		37-40/ 50-54	BT900 (Graphite) 09/88 →		09/88 →	
Swift 1.0L						03/89 →05/01	50	BT900 (Graphite)	DT900	GT900
Swift 1.0L i						03/89 →05/01			(21-28123-20/0)	(20-28123-00/0)
G10A	993	3	74.00	Injection		37-40/ 50-54				
Swift 1000 Turbo Diesel						11/84 →	51	BM740 (Graphite)		
G10T	993	3	74.00	Turbo						
Swift 1.3L						02/05 →	52	AG8180 (MLS)	CG8180	
Swift 1.3L 4x4						01/06 →				
M13A	1328	4	78.00	Injection		60-69/ 82-94				

								
		JC861  JF109	JN606 (31-028132-00)	JJ341	PA305 (x8)	 NJ336 32x47x8mm, NBR  NJ377  32x47x6mm, ACM  NJ378  68x86x8mm, ACM		
		JC641  JC859  JF109	JN606 (31-028132-00)	JJ341	PA305 (x8)	 NJ336 32x47x8mm, NBR  NJ377  32x47x6mm, ACM  NJ378  68x86x8mm, ACM		
		JC641  JF046  JF109	JN606 (31-028132-00)		PA305 (x8)	 NJ336 32x47x8mm, NBR  NJ377  32x47x6mm, ACM  NJ378  68x86x8mm, ACM		
HBS084  (22-15005B) M12x1.50x123mm (x10) HBS088  (22-15014B) M12x1.50x145mm (x10) →Eng.08574 HBS277  (22-53018B) M12x1.50x148mm (x10) Eng.08575→	JC991 (31-028595-00)	JN544 (50-025202-00)	JJ283 [6] (31-025198-10)	HR569  24-30667-00/0		 NF841 35x50x8mm, FPM (50-319310-00)  NA5191  42x62x7mm, PTFE (50-319500-00)  NA5192  90x110x7mm, PTFE (50-319501-00)	HL5010 [245] 	
	JC222  →12/85 JD097  01/86→ JE735 	JN414	JJ273	PA305 (x8)	 NJ336 32x47x8mm, NBR  NJ336  32x47x8mm, NBR  NJ337  60x80x8mm, NBR			
	JC641  JC859  JF109	JN606 (31-028132-00)	JJ341	PA305 (x8)	 NJ336 32x47x8mm, NBR  NJ377  32x47x6mm, ACM  NJ378  68x86x8mm, ACM			
	JD097  JE735	JN414	JJ273	PA305 (x8)	 NJ336 32x47x8mm, NBR  NJ336  32x47x8mm, NBR  NJ337  60x80x8mm, NBR			
HBS407  (22-73001B) M10x1.50x91mm (x8) HBS408  (22-73002B) M10x1.50x100mm (x8)	JC532 	JN579 →08/88		PA305 (x6) →01/88 PA096 (x6) [117] 01/88→	 NJ336 32x47x8mm, NBR →08/88  NJ337 60x80x8mm, NBR 09/88→  NJ337  60x80x8mm, NBR  NJ378  68x86x8mm, ACM			
HBS407  (22-73001B) M10x1.50x91mm (x8) HBS408  (22-73002B) M10x1.50x100mm (x8)	JC532 	JN579 →08/88		PA928 (x6) (50-319454-00)	 NJ337 60x80x8mm, NBR  NJ377  32x47x6mm, ACM  NJ378  68x86x8mm, ACM			
	JC532 	JN579		PA305 (x6) →01/88 PA096 (x6) [117] 01/88→	 NJ336 32x47x8mm, NBR →08/88  NJ337 60x80x8mm, NBR 09/88→  NJ337  60x80x8mm, NBR  NJ378  68x86x8mm, ACM			
		JM5312						
								
								
								
								
								
								



KW/PS

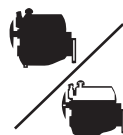

Model		Year Range		CC	Cyls	Power (kW/PS)	Configuration	Head Type	Part Number	Accessories	
Swift 1.3L		06/01 → 12/03				53			BN480 (Graphite)	CG5480	EG5220
G13BB		1299	4	74.00	MPI, SOHC	56-63/ 76-86			(30-028124-00)		
Swift 1.3L		10/84 → 03/89				54			BN480 (Graphite)	DN481	GN481
G13A		1324	4	74.00		44-54/ 60-73			(30-028124-00)	(21-28124-21/0)	(20-28124-02/0)
Swift 1.3L		03/89 → 05/01				55			BN480 (Graphite)	DN481	GN481
Swift 1.3L 4WD		03/89 → 05/01							(30-028124-00)	(21-28124-21/0)	(20-28124-02/0)
G13A		1324	4	74.00		44-54/ 60-73					
Swift 1.3L DDiS Diesel		08/05 →				56			AD5800 (MLS), 0.72mm	CD5800▲	
Z13DT		1248	4	82.00	Direct Injection	51/70			(30-029762-00)	(21-29762-20/0)	
									AD5810 (MLS), 0.82mm, 1 Hole		
									(30-029763-00)		
									AD5820 (MLS), 0.92mm, 2 Holes		
									(30-029764-00)		
Swift 1.3L GTi		03/89 → 05/01				57			BN480 (Graphite)	DN484	GN484
Swift Convertible 1.3L		09/91 → 10/96							(30-028124-00)	→ 12/94	
G13B		1298	4	74.00	DOHC	44-74/ 60-101			→ 12/94	CG5470	
										01/95 →	
Swift 1.3L GTi/GXi		08/86 → 03/89				58			BN480 (Graphite)	DN482	GN482
G13B		1298	4	74.00	DOHC	44-74/ 60-101			(30-028124-00)	(21-28124-22/0)	→ 12/88
										→ 12/88	GN484
										01/89 →	
Swift 1.6L 4x4		03/89 → 10/96				59			AG5260 (Fibre), 1.2mm	CG5510	EG5260
Swift 1.6L		11/89 → 12/91									
Swift 1.6L 4WD		11/89 → 12/91									
Swift 1.6L i		01/90 → 05/01									
Swift 1.6L i 4WD		01/90 → 05/01									
G16B		1590	4	75.00	MPI, SOHC	68-72/ 92-98					
Swift 1.6L		07/88 →				60			BS600 (Graphite)	DS600	GS600
G16A		1590	4	75.00	SOHC	50-60/ 68-82				(21-28125-20/0)	(20-28125-00/0)
SX4 2.0L		06/06 →				61			AG8020 (MLS)	CG8020	
Sx4 2.0L 4x4		06/06 →									
J20A		1995	4			107/146					
		1995	4	84.00	Injection	94-97/ 128- 132					
Vitara 1.6L		07/88 → 01/95				62			BS600 (Graphite)	DS600	EG5260
Vitara Cabrio 1.6L		07/88 → 01/95								(21-28125-20/0)	GS600
G16A		1590	4	75.00	SOHC	50-60/ 68-82					(20-28125-00/0)
Vitara 1.6L 16V		07/90 → 12/94				63			AG5260 (Fibre), 1.2mm	CG5510	EG5260
Vitara Cabrio 1.6L 16V		07/90 → 03/99								CG5511	
G16B		1590	4	75.00	MPI, SOHC	68-72/ 92-98				01/98 →	

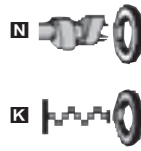
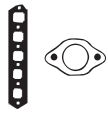

AD5800



AD5810



AD5820



BN480



BS600



JC641



JC859



JC861

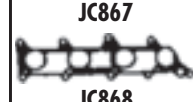

JC867



JC868



JD5412

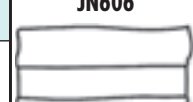

JN606



JN682



KW/PS

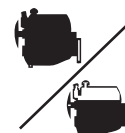

Vitaro 1.9L D Diesel		01/95 → 03/99		64		BX880 (Fibre), 1.36mm, 1 Notch (30-028475-00) 0.56 → 0.67mm BX890 (Fibre), 1.40mm, 2 Notches (30-028476-00) 0.68 → 0.71mm BX900 (Fibre), 1.44mm, 3 Notches (30-028477-00) 0.72 → 0.75mm BX910 (Fibre), 1.48mm, 4 Notches (30-028478-00) 0.76 → 0.79mm BX920 (Fibre), 1.52mm, 5 Notches (30-028479-00) 0.80 → 0.83mm	DJ720 ▲ (21-25202-22/0)	EL890 (22-25198-01/0) GJ720 ▲ (20-25202-02/0)
XUD9A	1905	4	83.00	SOHC	50/68			
XUD9SD	1905	4	83.00		55/75			
Vitaro Cabrio 1.9L D Diesel		01/95 → 03/98						
Vitaro 1.9L TD Diesel		01/98 →		65		BX930 (Steel Elastomer), 1.36mm, 1 Notch (30-028503-00) BX940 (Steel Elastomer), 1.40mm, 2 Notches (30-028504-00) BX950 (Steel Elastomer), 1.44mm, 3 Notches (30-028505-00) BX960 (Steel Elastomer), 1.48mm, 4 Notches (30-028506-00) BX970 (Steel Elastomer), 1.52mm, 5 Notches (30-028507-00)	DJ720 ▲ (21-25202-22/0)	EL890 (22-25198-01/0) GJ720 ▲ (20-25202-02/0)
XUD9TF/BTF (DHX)	1905	4	83.00	SOHC, Turbo	44/66/ 60/90			
Vitaro 2.0L 16V		12/96 → 03/98		66		AG8020 (MLS)	CG8020	
Vitaro Cabrio 2.0L 16V		12/96 → 03/99						
I20A	1995	4	84.00	Injection	94-97/ 128- 132			
Vitaro 2.0L TD Diesel		12/94 → 03/98		67		AG5130 (MLS), 1.5mm	CG5460	
Vitaro 2.0L TD Intercooler Diesel		12/95 → 03/98						
RF	1998	4	86.00	OHV	52-68/ 71-92			
Vitaro 2.0L V6 24V		12/94 → 03/98		68		AG5720 (Graphite) ☒ 01/95 → H20A AG5710 (Graphite) ☒ 01/95 → H20A	CG5710	
H20A	1998	6	78.00	DOHC, V6	100/136			
Vitaro 2.5L V6 24V		12/95 → 03/98		69		AG5740 (Graphite) ☒ 01/98 → H25A AG5730 (Graphite) ☒ 01/98 → H25A		
	2493	6			118/160			
Wagon R+ 1.0L		02/98 → 05/00		70		AG8120		
	996	4			48/65			
Wagon R+ 1.2L		02/98 → 05/00		71				
	1171	4			51/69			
Wagon R+ 1.2L		06/04 →		72			CH5031 (21-30366-01/0)	
Z 12 XEP	1229	4	73.40	Injection	59/80			
Wagon R+ 1.3L		05/00 →		73		BN480 (Graphite) (30-028124-00)	CG5480	EG5220
Wagon R+ 1.3L 4WD		10/01 →						
G13BB	1298	4			56/76			
	1299	4	74.00	MPi, SOHC	56-63/ 76-86			

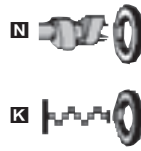
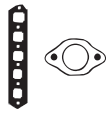

BN480



BX880, BX890,
BX900, BX910,
BX920



BX930, BX940,
BX950, BX960,
BX970



JC759



JC991



JN544



JJ283

HBS084 Ⓢ (22-15005B) M12x1.50x123mm (x10)	JC759 [60] (31-028417-00) (Steel)	JN544 (50-025202-00)	JJ283 [6] (31-025198-10) — PA349 (33-102290-10) 22x16x2mm	HR569 ■ 24-30667-00/0	■ NF841 35x50x8mm, FPM (50-319310-00) ■ NA5191 ■ 42x62x7mm, PTFE (50-319500-00) ■ NA5192 ■ 90x110x7mm, PTFE (50-319501-00)	HL5010 [245]■
HBS088 Ⓢ (22-15014B) M12x1.50x145mm (x10) →Eng.08574 HBS277 Ⓢ (22-53018B) M12x1.50x148mm (x10) Eng.08575→	JC991 (31-028595-00)	JN544 (50-025202-00)	JJ283 [6] (31-025198-10)		■ NF841 35x50x8mm, FPM (50-319310-00) ■ NA5191 ■ 42x62x7mm, PTFE (50-319500-00) ■ NA5192 ■ 90x110x7mm, PTFE (50-319501-00)	
HBS447 (22-73003B)		JM5304 01/98→				
HBS211 Ⓢ (22-75001B) M12x1.50x113mm (x10)						
		JM5308 ■ 01/95→ JM5307 ■ 01/95→				
		JM5308 ■ 01/98→ JM5307 ■ 01/98→				
		JM5309 (ACM) K10A				
		JM5309 (ACM) K12A				
		JM5071 (50-029232-00)				
	JD5770 ■ JD5769 ■	JN886				

SUZUKI



KW/PS



Wagon R+ 1.3L						08/01 →	74	AG8180 (MLS)	CG8180
Wagon R+ 1.3L 4WD						09/03 →			
Wagon R+ 1.3L VVTi GL Allrad						09/03 →			
M13A	1328	4	78.00	Injection		60-69/ 82-94			
Wagon R+ 1.3L DDiS Diesel						09/03 →	75	AD5800 (MLS), 0.72mm (30-029762-00) AD5810 (MLS), 0.82mm, 1 Hole (30-029763-00) AD5820 (MLS), 0.92mm, 2 Holes (30-029764-00)	CD5800▲ (21-29762-20/0)
Z13DT	1248	4	82.00	Direct Injection		51/70			
X-90 1.6L i 16V						09/95 →	76	AG5260 (Fibre), 1.2mm	CG5510
X-90 1.6L i 16V 4WD						09/95 →			
G16B	1590	4	75.00	MPI, SOHC		68-72/ 92-98		EG5260	

							<p>AD5800</p> <p>AD5810</p> <p>AD5820</p> <p>JD5412</p>
			JM5312				
HBS353 (22-17025B) M10x1.25x119mm (x10)	JD5411 (50-030025-00) JD5412 (50-030026-00) JD5413 (31-030027-00) (MLS)	JM5259 (31-030023-00)		HR5088 (24-31952-10/0)	NA5223 40x52x7mm, FPM (50-319520-00) NA5230 78x100x9mm, PTFE (50-319522-00)	KK5646 [45]	
	JD5770 JD5785 JD5769	JN886	JJ341				



CC



9



CC



9

150 D	Petrol	1351	4	75.00	26
1G1 / 371	Petrol	1294	4	76.70	11
1G1 / 371	Petrol	1294	4	76.70	3
2G1	Petrol	1294	4	76.70	11
2G1	Petrol	1294	4	76.70	13
2Y1B	Petrol	1442	4	76.70	14
2Y2	Petrol	1442	4	76.70	14
3E1	Petrol	1118	4	74.00	5
3E1A	Petrol	1118	4	74.00	5
3G4/366	Petrol	1294	4	76.70	18
3G4/366	Petrol	1294	4	76.70	7
5N2	Petrol	2156	4	81.60	21
5N2	Petrol	2156	4	81.60	33
6 Y2	Petrol	1442	4	76.70	28
6J1	Petrol	1592	4	80.60	29
6J1	Petrol	1592	4	80.60	32
6J2	Petrol	1592	4	80.60	29
6J2A	Petrol	1592	4	80.60	15
6J2A	Petrol	1592	4	80.60	9
6Y2D	Petrol	1442	4	76.70	28
7T2	Petrol	1959	4		1
E1	Petrol	1118	4	74.00	12
E1	Petrol	1118	4	74.00	2
G1	Petrol	1294	4	76.70	30
G1/G2	Petrol	1294	4	76.70	13
G1/G4	Petrol	1294	4	76.70	27
J1 / J2	Petrol	1592	4	80.60	32
J2A	Petrol	1592	4	80.60	15
L6	Petrol	2664	6	88.00	35
X5J2A	Petrol	1592	4	80.60	20
X5N2	Petrol	2128	4		21
XD25 (U8)	Diesel	2304	4	94.00	34
XUD 7	Diesel	1769	4	80.00	16
XUD9	Diesel	1905	4	83.00	17
XV5	Petrol	954	4	70.00	23
XV8	Petrol	954	4	70.00	23
XW7	Petrol	1124	4	72.00	24
XY7	Petrol	1360	4	75.00	26
XY8	Petrol	1360	4	75.00	26
XZ7R	Petrol	1219	4	75.00	25
Y1	Petrol	1442	4	76.70	31
Y1 / Y4	Petrol	1442	4	76.70	28
Y1/Y2	Petrol	1442	4	76.70	14
Y2	Petrol	1442	4	76.70	14
Y2 X3	Petrol	1442	4	76.70	22



KW/PS



Model						Year Range	Series	Part	Part	Part
180 2.0L						02/73 → 09/77	1	BL610 (Fibre), 1.35mm	DL611 ■○	
7T2	1959	4		Carburettor	81/110					
1000 1.1L Rallye						10/70 → 09/72	2	BF100 (Fibre), 1.30mm	DF106 ▲■○ (21-21887-20/0)	EF101 [12]
1000 1.1L Spezial						10/68 → 09/75		BG480 (Fibre), 1.80mm [34]	DF107 ▲■	
1000 1006 SR, GLS						10/76 → 07/78				
E1	1118	4	74.00	Carburettor	40/54					
1000 1.3L Rallye 1						10/72 → 09/77	3	BF170 (Fibre), 1.30mm (30-023495-10)	DF106 ▲■○ (21-21887-20/0)	EF101 [12]
1000 1.3L Spezial						08/74 → 09/77		BG490 (Fibre), 1.80mm [34]	DF107 ▲■	
1G1 / 371	1294	4	76.70	Carburettor	44/60					
1000 1.3L Rallye 2						09/72 → 09/77	4	BF170 (Fibre), 1.30mm (30-023495-10)		GF171 ■○
1000 Rallye 3						01/78 → 12/78		BG490 (Fibre), 1.80mm [34]		
	1294	4			60/82					
	1294	4			63/86					
	1294	4			76/103					
1100 1.1L						10/68 → 09/79	5	BF100 (Fibre), 1.30mm	DF106 ▲■○ (21-21887-20/0)	EF101 [12]
1100 1.1L LE, LX, GLS, ES						10/76 → 01/80		BG480 (Fibre), 1.80mm [34]		EF102
1100 LS, GLS						10/68 → 09/77				
3E1	1118	4	74.00	Carburettor	37-41/ 50-56					
3E1A	1118	4	74.00	Carburettor	43-44/ 58-60					
1100 Spezial						10/71 → 09/77	6	BF100 (Fibre), 1.30mm	DF106 ▲■○ (21-21887-20/0)	EF101 [12]
	1204	4			55/75		BG480 (Fibre), 1.80mm [34]	DF107 ▲■	EF102	
1100 1.3L Spezial TI						10/72 → 09/77	7	BF170 (Fibre), 1.30mm (30-023495-10)	DF106 ▲■○ (21-21887-20/0)	EF101 [12]
1100 Spezial						07/74 → 11/76		BG490 (Fibre), 1.80mm [34]	DF107 ▲■	EF102
3G4/366	1294	4	76.70	Carburettor	60-62/ 82-84					
1300 1.3L						08/66 → 07/72	8	BF110 (Fibre), 1.20mm		GF110 ○ [12]
1300 1.3L LS						08/66 → 07/72				
1300 1.3L Spezial						10/70 → 11/76				
1300 LS, GL, GLS						08/66 → 07/72				
	1290	4			40/54					
	1290	4			44/60					
	1290	4			49/67					
	1290	4			51/69					
1510 1510 1.6L						07/81 → 06/82	9		DF106 ▲■○ (21-21887-20/0)	EF102
6J2A	1592	4	80.60	Carburettor	66/89			DF107 ▲■		
1610 1610 2.0 D Diesel						09/76 → 12/80	10	BL610 (Fibre), 1.35mm	DL611 ■○	
	1918	4			44/60					
1307-1510 Simca 1307 1.3L						07/75 → 01/80	11	BF170 (Fibre), 1.30mm (30-023495-10)	DF106 ▲■○ (21-21887-20/0)	EF102
1G1 / 371	1294	4	76.70	Carburettor	44/60		BG490 (Fibre), 1.80mm [34]	DF107 ▲■		
2G1	1294	4	76.70	Carburettor	50/68					
Horizon 1.1L						01/79 → 09/84	12	BF100 (Fibre), 1.30mm	DF106 ▲■○ (21-21887-20/0)	EF101 [12]
E1	1118	4	74.00	Carburettor	40/54		BG480 (Fibre), 1.80mm [34]	DF107 ▲■	EF102	

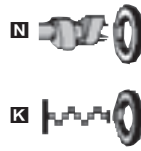
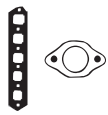

BF100, BG480



BF110



BF170, BG490



BL110



JB836



JB837



JN238



JN283



HC341







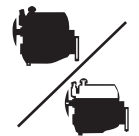



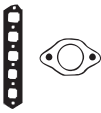

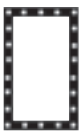

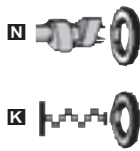



























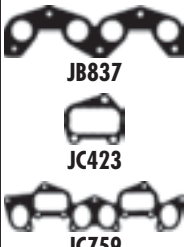







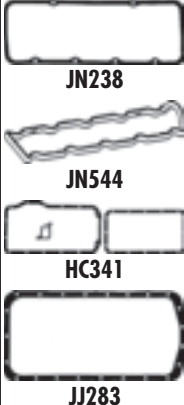









			≡KG5290 20.4x27x3mm		☒ NF694 40x58x8mm, ACM	
	JB836 JB837 (31-021888-10)	JN238 (31-021887-00)	≡KG5290 20.4x27x3mm		☒ NF695 40x58x8mm, ACM	
	JB836 JB837 (31-021888-10)	JN283	≡KG5290 20.4x27x3mm		☒ NF695 40x58x8mm, ACM	
	JB836 JB837 (31-021888-10)	JN238 (31-021887-00)	≡KG5290 20.4x27x3mm		☒ NF695 40x58x8mm, ACM	
	JB836 JB837 (31-021888-10)	JN238 (31-021887-00)	HC341 ≡KG5290 20.4x27x3mm		☒ NF694 40x58x8mm, ACM ☒ NF692 71x88x8mm, MVQ	NF032 (x2) [38] NF664 [214] NF562 [42]
	JB836 JB837 (31-021888-10)	JN238 (31-021887-00)	HC341 ≡KG5290 20.4x27x3mm		☒ NF694 40x58x8mm, ACM ☒ NF692 71x88x8mm, MVQ	NF032 (x2) [38] NF664 [214] NF562 [42] Speed selector
	JB836 JB837 (31-021888-10)	JN238 (31-021887-00)	HC341 ≡KG5290 20.4x27x3mm		☒ NF694 40x58x8mm, ACM ☒ NF692 71x88x8mm, MVQ	NF032 (x2) [38] NF664 [214] NF562 [42] Speed selector
			≡PA349 (33-102290-10) 22x16x2mm		☒ NF009 75x95x12mm, NBR	NF072 (x2) [2] ☒ ☒
	JB836 JB837 (31-021888-10)	JN238 (31-021887-00)	HC341 ≡KG5290 20.4x27x3mm		☒ NF694 40x58x8mm, ACM ☒ NF692 71x88x8mm, MVQ	NF032 (x2) [38]
			≡KG5290 20.4x27x3mm		☒ NF694 40x58x8mm, ACM	NF470 [42]
	JB836 JB837 (31-021888-10)	JN238 (31-021887-00)	HC341 ≡KG5290 20.4x27x3mm		☒ NF694 40x58x8mm, ACM ☒ NF692 71x88x8mm, MVQ	NF032 (x2) [38] NF562 [42]
	JB836 JB837 (31-021888-10)	JN238 (31-021887-00)	HC341 ≡KG5290 20.4x27x3mm		☒ NF694 40x58x8mm, ACM ☒ NF692 71x88x8mm, MVQ	NF032 (x2) [38] ☒ NF562 [42]



KW/PS



Model					Year Range	Cylinders	Power (KW/PS)	Fuel System	Head Part	Carburettor Part	Accessories
Horizon 1.3L					02/78 → 06/86						
G1/G2	1294	4	76.70	Carburettor	43/58					DF106▲■○ (21-21887-20/0)	EF101 [12] EF102
2G1	1294	4	76.70	Carburettor	50/68					DF107▲■	
Horizon 1.4L					07/79 → 06/86						
2Y1B	1442	4	76.70	Carburettor	48/65					DF106▲■○ (21-21887-20/0)	EF101 [12] EF102
Y1/Y2	1442	4	76.70	Carburettor	51/69					DF107▲■	
2Y2/Y2	1442	4	76.70	Carburettor	61/82						
Horizon 1.6L					07/82 → 06/86						
6J2A	1592	4	80.60	Carburettor	66/89					DF106▲■○ (21-21887-20/0)	EF101 [12] EF102
J2A	1592	4	80.60	Carburettor	66/90					DF107▲■	
Horizon 1.7LD Diesel					07/83 → 06/85						
XUD 7	1769	4	80.00		44/60					DJ720▲ (21-25202-22/0)	EL890 (22-25198-01/0) GJ720▲ (20-25202-02/0)
Horizon 1.9L D Diesel					07/82 → 06/86						
XUD9	1905	4	83.00		48/65					DJ720▲ (21-25202-22/0)	EL890 (22-25198-01/0) GJ720▲ (20-25202-02/0)
Matra Bagheera Coupe 1.3L					01/74 → 03/78						
3G4/366	1294	4	76.70	Carburettor	60-62/ 82-84					DF106▲■○ (21-21887-20/0)	EF101 [12] EF102
Matra Bagheera Coupe 1.4L					12/75 → 11/79						
	1442	4			66/90					DF106▲■○ (21-21887-20/0)	EF101 [12] EF102
Murena Coupe 1.6L					08/81 → 01/85						
X5J2A	1592	4	80.60	Carburettor	66/90					DF106▲■○ (21-21887-20/0)	EF102
Murena 2.1L S					04/83 → 01/85						
Murena Coupe 2.1L					09/80 → 07/84						
X5N2	2128	4		Carburettor	103/140					DL611■○	
5N2	2156	4	81.60	Carburettor	82-85/ 112- 116						
Rancho 1.4L					01/77 → 07/84						
Y2 X3	1442	4	76.70	Carburettor	59/80					DF106▲■○ (21-21887-20/0)	EF101 [12] EF102















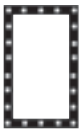

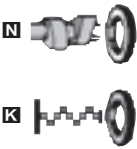



								 BF170, BG490
		JB836  JB837  (31-021888-10)	JN238 (31-021887-00)	HC341  = KG5290 20.4x27x3mm		NF694  40x58x8mm, ACM NF692  71x88x8mm, MVQ	NF032 (x2) [38] NF562 [42]	 BL610
		JB836  JB837  (31-021888-10)	JN238 (31-021887-00)	HC341  = KG5290 20.4x27x3mm		NF694  40x58x8mm, ACM NF692  71x88x8mm, MVQ	NF032 (x2) [38] NF562 [42]	 BX830, BX840, BX850, BX860, BX870, BX880, BX890, BX900, BX910, BX920
		JB836  JB837  (31-021888-10)	JN238 (31-021887-00)	HC341  = KG5290 20.4x27x3mm		NF694  40x58x8mm, ACM NF692  71x88x8mm, MVQ	NF032 (x2) [38] NF562 [42]	 JB836
HBS084  (22-15005B) M12x1.50x123mm (x10)	JC423  (x2) (31-025199-10)	JN544 (50-025202-00)	JJ283 [6] (31-025198-10) = PA349 (33-102290-10) 22x16x2mm	HR569  24-30667-00/0	NF841  35x50x8mm, FPM (50-319310-00) NA5191  42x62x7mm, PTFE (50-319500-00) NA5192  90x110x7mm, PTFE (50-319501-00)	HL5010 [245]  NF032 (x2) [38] NF562 [42]	 JB836 JB837 JC423 JC759	
HBS084  (22-15005B) M12x1.50x123mm (x10)	JC759 [60] (31-028417-00) (Steel) JC423  (x2) (31-025199-10)	JN544 (50-025202-00)	JJ283 [6] (31-025198-10) = PA349 (33-102290-10) 22x16x2mm	HR569  24-30667-00/0	NF841  35x50x8mm, FPM (50-319310-00) NA5191  42x62x7mm, PTFE (50-319500-00) NA5192  90x110x7mm, PTFE (50-319501-00)	HL5010 [245]  NF032 (x2) [38] NF562 [42]	 JN238 JN544 HC341 JJ283	
	JB836  JB837  (31-021888-10)	JN238 (31-021887-00)	HC341  = KG5290 20.4x27x3mm		NF694  40x58x8mm, ACM NF692  71x88x8mm, MVQ	NF032 (x2) [38] NF562 [42]		
	JB836  JB837  (31-021888-10)	JN238 (31-021887-00)	HC341  = KG5290 20.4x27x3mm		NF694  40x58x8mm, ACM NF692  71x88x8mm, MVQ	NF032 (x2) [38] NF562 [42]		
	JB836  JB837  (31-021888-10)	JN238 (31-021887-00)	HC341  = KG5290 20.4x27x3mm		NF694  40x58x8mm, ACM NF692  71x88x8mm, MVQ			
			= KG5290 20.4x27x3mm					
	JB836  JB837  (31-021888-10)	JN238 (31-021887-00)	HC341  = KG5290 20.4x27x3mm		NF694  40x58x8mm, ACM NF692  71x88x8mm, MVQ	NF032 (x2) [38] NF562 [42]		



KW/PS



Samba 0.9L				01/81 → 12/85		23	BF290 (Fibre), 1.20mm [33] (30-023670-10) →11/85 BN570 (Fibre), 1.20mm [35] (30-026351-10) 11/85→	DN571▲	EH950 [36]
XV8	954	4	70.00	Carburettor	31/42				
XV5	954	4	70.00	Carburettor	31-33/ 42-45				
Samba 1.1L				01/81 → 06/86		24	BH950 (Fibre), 1.20mm, 1 Notch [33] (30-025152-10) BL620 (Fibre), 1.40mm [33] [34]	DN571▲	EH950 [36]
XW7	1124	4	72.00	Carburettor	37/50				
Samba 1.2L Rallye				01/83 → 10/86		25	BH950 (Fibre), 1.20mm, 1 Notch [33] (30-025152-10) BL620 (Fibre), 1.40mm [33] [34]	DN571▲	EH950 [36]
XZ7R	1219	4	75.00	Carburettor	65/88				
Samba 1.4L				01/81 → 10/86		26	BH950 (Fibre), 1.20mm, 1 Notch [33] (30-025152-10) →11/85 BL620 (Fibre), 1.40mm [33] [34] →11/85 BN580 (Fibre), 1.20mm [35] (30-026021-10) 11/85→	DN582▲	EH950 [36]
Samba 1.4L Rallye				01/83 → 10/86					
Samba Convertible 1.4L				01/81 → 06/86					
150 D	1351	4	75.00	Carburettor	44/60				
XY7	1360	4	75.00	Carburettor	53/72				
XY8	1360	4	75.00	Carburettor	59/80				
Simca 1307 1.3L				01/78 → 08/81		27	BF170 (Fibre), 1.30mm (30-023495-10) BG490 (Fibre), 1.80mm [34]	DF106▲■○ (21-21887-20/0) DF107▲■	EF102
G1/G4	1294	4	76.70	Carburettor	40/54				
Simca 1.4L				01/80 → 12/83		28	BF170 (Fibre), 1.30mm (30-023495-10) BG490 (Fibre), 1.80mm [34]	DF106▲■○ (21-21887-20/0) DF107▲■	EF101 [12] EF102
Simca 1308 1.4L				11/78 → 08/81					
Simca 1510 1.4L				01/80 → 04/84					
Y1 / Y4	1442	4	76.70	Carburettor	51/69				
6Y2D	1442	4	76.70	Carburettor	55/75				
6 Y2	1442	4	76.70	Carburettor	55-63/ 75-86				











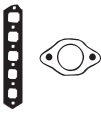

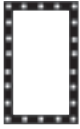

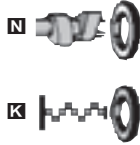

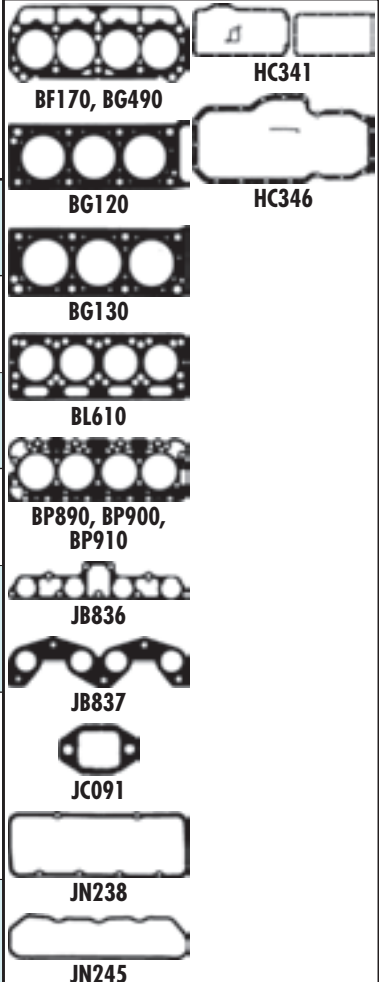

















	  						 <p>BF170, BG490</p>  <p>BF290, BN570</p>  <p>BH950, BL620</p>  <p>BN580</p>  <p>JB836</p>  <p>JB837</p>  <p>JC135</p>  <p>JE647</p>  <p>JN238</p>  <p>JN596</p>  <p>HC341</p>
		JN596 <i>(50-023671-00)</i>	≡PA349 <i>(33-102290-10)</i> 22x16x2mm	HR300	☒ NF678 35x50x8mm, ACM ☒ NF641 78x100x10mm, MVQ	HR564 [37] ☒ Rubber HR571 [37] ☒ NF526 (x2) [2] ☒ ☒ NF836 (x2) [38] ☒ HG108 [39] [40] ☒ Clutch housing set HL442 [39] [41] ☒ Clutch housing set HG087 [43] [44] ☒ LV847 [45] LT832 [46]	
	JC135 ☒  JE647 [47] <i>(31-022193-10)</i>	JN596 <i>(50-023671-00)</i>	≡PA349 <i>(33-102290-10)</i> 22x16x2mm	HR300	☒ NF678 35x50x8mm, ACM ☒ NF641 78x100x10mm, MVQ	HR564 [37] ☒ NF526 (x2) [2] ☒ ☒ NF836 (x2) [38] ☒ HG108 [39] [40] ☒ Clutch housing set HL442 [39] [41] ☒ Clutch housing set HG087 [43] [44] ☒ HG104 [43] [48] ☒ LV847 [45] LT832 [46]	
		JN596 <i>(50-023671-00)</i>	≡PA349 <i>(33-102290-10)</i> 22x16x2mm	HR300	☒ NF678 35x50x8mm, ACM ☒ NF641 78x100x10mm, MVQ	HR564 [37] ☒ NF526 (x2) [2] ☒ ☒ NF836 (x2) [38] ☒ HG108 [39] [40] ☒ Clutch housing set HL442 [39] [41] ☒ Clutch housing set HG104 [43] [48] ☒ LV847 [45] LT832 [46]	
	JC135 ☒	JN596 <i>(50-023671-00)</i>	≡PA349 <i>(33-102290-10)</i> 22x16x2mm	HR300	☒ NF678 35x50x8mm, ACM ☒ NF641 78x100x10mm, MVQ	HR564 [37] ☒ NF526 (x2) [2] ☒ ☒ NF836 (x2) [38] ☒ HG108 [39] [40] ☒ Clutch housing set HL442 [39] [41] ☒ Clutch housing set HG093 [43] [48] ☒ LV847 [45] LT832 [46]	
	JB836 ☒ JB837 ☒ <i>(31-021888-10)</i>	JN238 <i>(31-021887-00)</i>	HC341 ☒ ≡KG5290 20.4x27x3mm		☒ NF694 40x58x8mm, ACM ☒ NF692 71x88x8mm, MVQ	NF032 (x2) [38] NF562 [42]	
	JB836 ☒ JB837 ☒ <i>(31-021888-10)</i>	JN238 <i>(31-021887-00)</i>	HC341 ☒ ≡KG5290 20.4x27x3mm		☒ NF694 40x58x8mm, ACM ☒ NF692 71x88x8mm, MVQ	NF032 (x2) [38] NF562 [42]	



















KW/PS











Model						Year Range	Power (KW/PS)	Notes	Accessories
Simca 1510 1.6L						10/78 → 12/83	29		DF106▲■○ (21-21887-20/0) EF102
6J1	1592	4	80.60	Carburettor	54/73				
6J2	1592	4	80.60	Carburettor	65/88			DF107▲■	
Solara 1.3L						02/80 → 07/86	30	BF170 (Fibre), 1.30mm (30-023495-10) BG490 (Fibre), 1.80mm [34]	DF106▲■○ (21-21887-20/0) EF101 [12] EF102 DF107▲■
G1	1294	4	76.70	Carburettor	40/54				
Solara 1.4L						01/80 → 12/86	31	BF170 (Fibre), 1.30mm (30-023495-10) BG490 (Fibre), 1.80mm [34]	DF106▲■○ (21-21887-20/0) EF101 [12] EF102
Y1	1442	4	76.70	Carburettor	51/69				
Solara 1.6L						09/81 → 07/86	32		DF106▲■○ (21-21887-20/0) EF101 [12] EF102 DF107▲■
6J1	1592	4	80.60	Carburettor	54/73				
J1 / J2	1592	4	80.60	Carburettor	66/90				
Tagora 2.1L						06/80 → 12/83	33	BL610 (Fibre), 1.35mm	DL611■○
5N2	2156	4	81.60	Carburettor	82-85/ 112- 116				
Tagora 2.3L TD Diesel						08/81 → 12/87	34	BP890 (Fibre), 1.53mm, 2 Notches (30-026144-10) BP900 (Fibre), 1.63mm, 3 Notches (30-026145-10) BP910 (Fibre), 1.73mm, 4 Notches (30-026146-10)	DG052▲ (21-24586-25/0) EH890 GG052▲○ (20-24586-04/0)
XD2S (U8)	2304	4	94.00		59/80				
Tagora 2.6L						08/81 → 10/83	35	BG120 (Fibre), 1.20mm ☒ BG130 (Fibre), 1.20mm ☒ (30-024150-10)	DF106▲■○ (21-21887-20/0)
L6	2664	6	88.00	Carburettor	122/166				

								
		JB836  JB837  <i>(31-021888-10)</i>	JN238 <i>(31-021887-00)</i>	HC341  —KG5290 20.4x27x3mm		NF694  40x58x8mm, ACM NF692  71x88x8mm, MVQ	NF032 (x2) [38]	BF170, BG490 HC341 HC346 BG120 BG130 BL610 BP890, BP900, BP910 JB836 JB837 JC091 JN238 JN245
		JB836  JB837  <i>(31-021888-10)</i>	JN238 <i>(31-021887-00)</i>	HC341  —KG5290 20.4x27x3mm		NF694  40x58x8mm, ACM NF692  71x88x8mm, MVQ	NF032 (x2) [38] NF562 [42]	
		JB836  JB837  <i>(31-021888-10)</i>	JN238 <i>(31-021887-00)</i>	HC341 		NF694  40x58x8mm, ACM NF692  71x88x8mm, MVQ	NF032 (x2) [38]	
		JB837  <i>(31-021888-10)</i>	JN238 <i>(31-021887-00)</i>	HC341  —KG5290 20.4x27x3mm		NF694  40x58x8mm, ACM NF692  71x88x8mm, MVQ	NF032 (x2) [38] 	
				—KG5290 20.4x27x3mm			NF115 (x2) [38] NF334 [38]	
HBS015  <i>(22-53004B)</i> M11x1.50x97.5mm (x8) M11x1.50x120mm (x7) M11x1.50x107.5mm (x7)	JC091  (x2) <i>(31-026150-10)</i>	JN245 <i>(50-024586-00)</i>	HC346  —PA349 <i>(33-102290-10)</i> 22x16x2mm			NF387  42x60x10mm, NBR <i>(50-306429-00)</i>	KA606 [13]	
			—KG5290 20.4x27x3mm	HR300  (x2)		NF761  42x62x10mm, FPM/ACM <i>(50-319355-00)</i> NF634  80x100x13mm, MVQ <i>(50-319343-00)</i>		

		CC			9			CC			9
11B	Diesel	2977	4	95.00	203	1HD-FTE	Diesel	4164	6	94.00	270
11B	Diesel	2977	4	95.00	375	1HD-T	Diesel	4163	6	94.00	269
12HT	Diesel	3980	6	91.00	107	1KD-FTV	Diesel	2982	4	96.00	256
12HT	Diesel	3980	6	91.00	266	1KR-FE	Petrol	998	3	71.00	28
12HT	Diesel	3980	6	91.00	33	1KR-FE	Petrol	998	3	71.00	303
13B	Diesel	3432	4	102.00	204	1KR-FE	Petrol	998	3	71.00	31
13B	Diesel	3432	4	102.00	205	1KR-FE	Petrol	998	3	71.00	384
13B	Diesel	3432	4	102.00	259	1KR-FE	Petrol	998	3	71.00	391
13BT	Diesel	3431	4	102.00	206	1KZ-T	Diesel	2982	4	96.00	257
13BT	Diesel	3431	4	102.00	262	1KZ-T	Diesel	2982	4	96.00	6
13T	Petrol	1770	4	85.00	59	1KZ-TE	Diesel	2982	4	96.00	258
18R	Petrol	1968	4	88.50	174	1MZ-FE	Petrol	2995	6	87.50	50
18R	Petrol	1968	4	88.50	86	1N	Diesel	1453	4	74.00	349
1AZ FE	Petrol	1998	4	86.00	26	1ND-TV	Diesel	1364	4	73.00	119
1AZ FE	Petrol	1998	4	86.00	322	1ND-TV	Diesel	1364	4	73.00	208
1AZ FE	Petrol	1998	4	86.00	325	1ND-TV	Diesel	1364	4	73.00	351
1AZ FE	Petrol	1998	4	86.00	43	1ND-TV	Diesel	1364	4	73.00	386
1AZ-FSE	Petrol	1998	4	86.00	12	1ND-TV	Diesel	1364	4	73.00	396
1AZ-FSE	Petrol	1998	4	86.00	15	1ND-TV	Diesel	1364	4	73.00	397
1AZ-FSE	Petrol	1998	4	86.00	211	1NZ-FE	Petrol	1497	4	75.00	11
1AZ-FSE	Petrol	1998	4	86.00	22	1NZ-FE	Petrol	1497	4	75.00	120
1AZ-FSE	Petrol	1998	4	86.00	231	1NZ-FE	Petrol	1497	4	75.00	14
1AZ-FSE	Petrol	1998	4	86.00	246	1NZ-FE	Petrol	1497	4	75.00	209
1AZ-FSE	Petrol	1998	4	86.00	300	1NZ-FE	Petrol	1497	4	75.00	210
1AZ-FSE	Petrol	1998	4	86.00	301	1NZ-FE	Petrol	1497	4	75.00	247
1AZ-FSE	Petrol	1998	4	86.00	34	1NZ-FE	Petrol	1497	4	75.00	30
1AZ-FSE	Petrol	1998	4	86.00	390	1NZ-FE	Petrol	1497	4	75.00	312
1C	Diesel	1839	4	83.00	140	1NZ-FE	Petrol	1497	4	75.00	313
1C	Diesel	1839	4	83.00	141	1NZ-FE	Petrol	1497	4	75.00	318
1C	Diesel	1839	4	83.00	143	1NZ-FE	Petrol	1497	4	75.00	319
1C	Diesel	1839	4	83.00	146	1NZ-FE	Petrol	1497	4	75.00	32
1C	Diesel	1839	4	83.00	161	1NZ-FE	Petrol	1497	4	75.00	320
1C	Diesel	1839	4	83.00	279	1NZ-FE	Petrol	1497	4	75.00	329
1CD-FTV	Diesel	1995	4	82.20	150	1NZ-FE	Petrol	1497	4	75.00	352
1CD-FTV	Diesel	1995	4	82.20	155	1NZ-FE	Petrol	1497	4	75.00	377
1CD-FTV	Diesel	1995	4	82.20	21	1NZ-FE	Petrol	1497	4	75.00	387
1CD-FTV	Diesel	1995	4	82.20	24	1NZ-FE	Petrol	1497	4	75.00	389
1CD-FTV	Diesel	1995	4	82.20	314	1NZ-FE	Petrol	1497	4	75.00	398
1CD-FTV	Diesel	1995	4	82.20	324	1NZ-FE	Petrol	1497	4	75.00	399
1CD-FTV	Diesel	1995	4	82.20	359	1NZ-FXE	Petrol	1497	4	75.00	317
1C-L	Diesel	1839	4	83.00	142	1RZ	Petrol	1998	4	86.00	216
1C-L	Diesel	1839	4	83.00	144	1S	Petrol	1832	4	80.50	159
1C-L	Diesel	1839	4	83.00	145	1S	Petrol	1832	4	80.50	172
1C-L	Diesel	1839	4	83.00	369	1S	Petrol	1832	4	80.50	182
1C-L	Diesel	1839	4	83.00	60	1S	Petrol	1832	4	80.50	378
1C-TL	Diesel	1839	4	83.00	37	1S	Petrol	1832	4	80.50	77
1C-TL	Diesel	1839	4	83.00	379	1S	Petrol	1832	4	80.50	99
1E	Petrol	999	4	70.50	343	1S-EL	Petrol	1832	4	80.50	61
1E-L	Petrol	999	4	70.50	344	1S-L	Petrol	1832	4	80.50	36
1FZ-FE	Petrol	4477	6	100.00	272	1S-L	Petrol	1832	4	80.50	61
1G-E	Petrol	1988	6	75.00	176	1SZ-FE	Petrol	998	4	69.00	207
1G-E	Petrol	1988	6	75.00	184	1SZ-FE	Petrol	998	4	69.00	311
1G-E	Petrol	1988	6	75.00	83	1SZ-FE	Petrol	998	4	69.00	382
1G-EU	Petrol	1988	6	75.00	103	1SZ-FE	Petrol	998	4	69.00	383
1G-EU	Petrol	1988	6	75.00	167	1SZ-FE	Petrol	998	4	69.00	392
1G-EU	Petrol	1988	6	75.00	330	1UZ-FE	Petrol	3969	8	87.50	195
1G-FE	Petrol	1988	6	75.00	100	1UZ-FE	Petrol	3969	8	87.50	283
1G-FE	Petrol	1988	6	75.00	13	1UZ-FE	Petrol	3969	8	87.50	332
1G-FE	Petrol	1988	6	75.00	166	1UZ-FE	Petrol	3969	8	87.50	98
1G-FE	Petrol	1988	6	75.00	173	1WZ	Diesel	1867	4	82.20	149
1G-FE	Petrol	1988	6	75.00	183	1Y	Petrol	1626	4	86.00	277
1G-FE	Petrol	1988	6	75.00	187	1ZZ-FE	Petrol	1794	4	79.00	148
1G-FE	Petrol	1988	6	75.00	284	1ZZ-FE	Petrol	1794	4	79.00	18
1G-GE	Petrol	1988	6	75.00	102	1ZZ-FE	Petrol	1794	4	79.00	293
1G-GE	Petrol	1988	6	75.00	168	1ZZ-FE	Petrol	1794	4	79.00	321
1G-GE	Petrol	1988	6	75.00	175	1ZZ-FE	Petrol	1794	4	79.00	79
1G-GE	Petrol	1988	6	75.00	185	21R-C	Petrol	1972	4	84.00	87
1G-GE	Petrol	1988	6	75.00	189	21R-U	Petrol	1972	4	84.00	87
1HD-FT	Diesel	4164	6	94.00	271	22R	Petrol	2366	4	92.00	104

		CC			9			CC			9
22R	Petrol	2366	4	92.00	169	2KD-FTV	Diesel	2494	4	92.00	245
22R	Petrol	2366	4	92.00	237	2KD-FTV	Diesel	2494	4	92.00	248
22R	Petrol	2366	4	92.00	249	2L	Diesel	2446	4	92.00	190
22R	Petrol	2366	4	92.00	250	2L	Diesel	2446	4	92.00	199
22R	Petrol	2366	4	92.00	304	2L	Diesel	2446	4	92.00	221
22R	Petrol	2366	4	92.00	93	2L	Diesel	2446	4	92.00	222
22RE	Petrol	2366	4	92.00	237	2L	Diesel	2446	4	92.00	223
22RE	Petrol	2366	4	92.00	250	2L	Diesel	2446	4	92.00	224
22REC	Petrol	2367	4	92.00	2	2L	Diesel	2446	4	92.00	235
22REC	Petrol	2367	4	92.00	305	2L	Diesel	2446	4	92.00	236
22RTEC	Petrol	2367	4	92.00	105	2L	Diesel	2446	4	92.00	239
22RTEC	Petrol	2367	4	92.00	306	2L	Diesel	2446	4	92.00	251
2A	Petrol	1295	4	76.00	360	2L	Diesel	2446	4	92.00	373
2A-L	Petrol	1296	4	92.00	113	2L-T	Diesel	2446	4	92.00	178
2A-L	Petrol	1296	4	92.00	114	2L-T	Diesel	2446	4	92.00	225
2A-L	Petrol	1296	4	92.00	170	2L-T	Diesel	2446	4	92.00	238
2A-L	Petrol	1296	4	92.00	334	2L-T	Diesel	2446	4	92.00	252
2AZ-FE	Petrol	2362	4	88.50	27	2L-T	Diesel	2446	4	92.00	253
2AZ-FE	Petrol	2362	4	88.50	316	2L-T	Diesel	2446	4	92.00	3
2AZ-FE	Petrol	2362	4	88.50	326	2L-TE	Diesel	2446	4	92.00	179
2AZ-FE	Petrol	2362	4	88.50	47	2L-TE	Diesel	2446	4	92.00	191
2C	Diesel	1974	4	86.00	151	2NZ-FE	Petrol	1299	4	75.00	385
2C	Diesel	1974	4	86.00	152	2NZ-FE	Petrol	1299	4	75.00	388
2C	Diesel	1974	4	86.00	162	2NZ-FE	Petrol	1299	4	75.00	394
2C	Diesel	1974	4	86.00	164	2RZ	Petrol	2438	4	95.00	220
2C	Diesel	1974	4	86.00	196	2RZ-E	Petrol	2438	4	95.00	220
2C	Diesel	1974	4	86.00	281	2S	Petrol	1995	4	84.00	101
2C	Diesel	1974	4	86.00	285	2S	Petrol	1995	4	84.00	165
2C	Diesel	1974	4	86.00	286	2S	Petrol	1995	4	84.00	177
2C	Diesel	1974	4	86.00	342	2S	Petrol	1995	4	84.00	186
2C	Diesel	1974	4	86.00	35	2S	Petrol	1995	4	84.00	82
2C	Diesel	1974	4	86.00	366	2S-E	Petrol	1995	4	84.00	39
2C	Diesel	1974	4	86.00	370	2S-EL	Petrol	1995	4	84.00	39
2C	Diesel	1974	4	86.00	65	2S-ELC	Petrol	1995	4	84.00	39
2C-E	Diesel	1975	4	86.00	153	2SZ-FE	Petrol	1298	4	72.00	393
2C-E	Diesel	1975	4	86.00	154	2SZ-FE	Petrol	1298	4	72.00	395
2C-L	Diesel	1975	4	86.00	64	2TGEU	Petrol	1588	4	85.00	72
2C-T	Diesel	1975	4	86.00	156	2TZ-FE	Petrol	2438	4	95.00	315
2C-T	Diesel	1975	4	86.00	20	2UZ-FE	Petrol	4664	8	94.00	10
2C-T	Diesel	1975	4	86.00	285	2UZ-FE	Petrol	4664	8	94.00	273
2C-T	Diesel	1975	4	86.00	328	2VZ-FE	Petrol	2507	6	87.50	48
2C-T	Diesel	1975	4	86.00	372	2Y	Petrol	1812	4	86.00	215
2C-T	Diesel	1975	4	86.00	381	2Y	Petrol	1812	4	86.00	230
2C-T	Diesel	1975	4	86.00	41	2Y	Petrol	1812	4	86.00	278
2C-T	Diesel	1975	4	86.00	42	2Y	Petrol	1812	4	86.00	333
2C-T	Diesel	1975	4	86.00	70	2ZZ-GE	Petrol	1796	4	82.00	138
2C-TE	Diesel	1975	4	86.00	25	2ZZ-GE	Petrol	1796	4	82.00	147
2C-TE	Diesel	1975	4	86.00	71	2ZZ-GE	Petrol	1796	4	82.00	78
2C-TL	Diesel	1974	4	86.00	40	3A	Petrol	1453	4	77.50	364
2E	Petrol	1296	4	73.00	109	3A-C	Petrol	1452	4	77.50	365
2E	Petrol	1296	4	73.00	110	3A-LU	Petrol	1452	4	77.50	123
2E	Petrol	1296	4	73.00	112	3A-U	Petrol	1453	4	77.50	122
2E	Petrol	1296	4	73.00	335	3A-U	Petrol	1453	4	77.50	171
2E	Petrol	1296	4	73.00	348	3A-U	Petrol	1453	4	77.50	337
2E-E	Petrol	1296	4	73.00	109	3B	Diesel	3432	4	102.00	106
2E-E	Petrol	1296	4	73.00	110	3B	Diesel	3432	4	102.00	260
2E-E	Petrol	1296	4	73.00	348	3C-TE	Diesel	2184	4	86.00	157
2E-L	Petrol	1296	4	73.00	109	3C-TE	Diesel	2184	4	86.00	310
2E-LC	Petrol	1295	4	73.00	109	3E	Petrol	1456	4	73.00	121
2E-LC	Petrol	1295	4	73.00	345	3E	Petrol	1456	4	73.00	214
2F	Petrol	4229	6	94.00	267	3E	Petrol	1456	4	73.00	362
2F	Petrol	4229	6	94.00	268	3E-E	Petrol	1456	4	73.00	361
2H	Diesel	3980	6	91.00	265	3F	Petrol	3995	6	94.00	263
2J	Diesel	2449	4	88.00	200	3F-E	Petrol	3956	6	94.00	264
2J	Diesel	2449	4	88.00	201	3K	Petrol	1166	4	75.00	229
2JZ-GTE	Petrol	2997	6	86.00	354	3L	Diesel	2779	4	96.00	228
2KD-FTV	Diesel	2494	4	92.00	202	3L	Diesel	2779	4	96.00	242
2KD-FTV	Diesel	2494	4	92.00	226	3L	Diesel	2779	4	96.00	374
2KD-FTV	Diesel	2494	4	92.00	240	3RZ-FE	Petrol	2694	4	95.00	227

		CC			9			CC			9
3RZ-FE	Petrol	2694	4	95.00	241	4A-GEC	Petrol	1587	4	81.00	137
3RZ-FE	Petrol	2694	4	95.00	255	4A-GEL	Petrol	1587	4	81.00	133
3RZ-FE	Petrol	2694	4	95.00	356	4A-GEL	Petrol	1587	4	81.00	292
3RZ-FE	Petrol	2694	4	95.00	358	4A-GEL	Petrol	1587	4	81.00	73
3RZ-FE	Petrol	2694	4	95.00	4	4A-GEL	Petrol	1587	4	81.00	75
3S-FE	Petrol	1998	4	86.00	163	4A-GELC	Petrol	1587	4	81.00	292
3S-FE	Petrol	1998	4	86.00	23	4A-GELC	Petrol	1587	4	81.00	73
3S-FE	Petrol	1998	4	86.00	294	4A-GEU	Petrol	1587	4	81.00	131
3S-FE	Petrol	1998	4	86.00	295	4A-GEU	Petrol	1587	4	81.00	158
3S-FE	Petrol	1998	4	86.00	308	4A-GEU	Petrol	1587	4	81.00	274
3S-FE	Petrol	1998	4	86.00	309	4A-GEU	Petrol	1587	4	81.00	341
3S-FE	Petrol	1998	4	86.00	323	4A-GEU	Petrol	1587	4	81.00	376
3S-FE	Petrol	1998	4	86.00	327	4A-GEU	Petrol	1587	4	81.00	57
3S-FE	Petrol	1998	4	86.00	38	4A-GEU	Petrol	1587	4	81.00	74
3S-FE	Petrol	1998	4	86.00	380	4A-GZE	Petrol	1587	4	81.00	132
3S-FE	Petrol	1998	4	86.00	62	4A-GZE	Petrol	1587	4	81.00	291
3S-FE	Petrol	1998	4	86.00	63	4A-GZE	Petrol	1587	4	81.00	340
3S-FE	Petrol	1998	4	86.00	66	4A-L	Petrol	1588	4	81.00	52
3S-FE	Petrol	1998	4	86.00	67	4A-LC	Petrol	1587	4	81.00	126
3S-FE	Petrol	1998	4	86.00	69	4A-LC	Petrol	1587	4	81.00	51
3S-GE	Petrol	1998	4	86.00	297	4E-FE	Petrol	1331	4	74.00	115
3S-GE	Petrol	1998	4	86.00	298	4E-FE	Petrol	1331	4	74.00	117
3S-GE	Petrol	1998	4	86.00	68	4E-FE	Petrol	1331	4	74.00	118
3S-GE	Petrol	1998	4	86.00	88	4E-FE	Petrol	1331	4	74.00	213
3S-GE	Petrol	1998	4	86.00	89	4E-FE	Petrol	1331	4	74.00	346
3S-GE	Petrol	1998	4	86.00	90	4K	Petrol	1290	4	75.00	108
3S-GEL	Petrol	1998	4	86.00	81	4K	Petrol	1290	4	75.00	111
3S-GEL	Petrol	1998	4	86.00	85	4K	Petrol	1290	4	75.00	275
3S-GELC	Petrol	1984	4	86.00	85	4K	Petrol	1290	4	75.00	336
3S-GTE	Petrol	1998	4	86.00	296	4K	Petrol	1290	4	75.00	368
3S-GTE	Petrol	1998	4	86.00	84	4K-C	Petrol	1290	4	75.00	108
3VZ-E	Petrol	2958	6	87.50	244	4K-C	Petrol	1290	4	75.00	275
3VZ-E	Petrol	2958	6	87.50	307	4K-C	Petrol	1290	4	75.00	347
3VZ-E	Petrol	2958	6	87.50	357	4KJ	Petrol	1290	4	75.00	367
3VZ-E	Petrol	2958	6	87.50	5	4M-EU	Petrol	2563	6	80.00	180
3VZ-E	Petrol	2958	6	87.50	7	4M-EU	Petrol	2563	6	80.00	94
3VZ-FE	Petrol	2959	6	87.50	49	4S-FE	Petrol	1838	4	82.50	160
3Y	Petrol	1998	4	86.00	188	4Y	Petrol	2237	4	91.00	1
3Y	Petrol	1998	4	86.00	197	4Y	Petrol	2237	4	91.00	198
3Y	Petrol	1998	4	86.00	217	4Y	Petrol	2237	4	91.00	219
3Y	Petrol	1998	4	86.00	218	4Y	Petrol	2237	4	91.00	234
3Y	Petrol	1998	4	86.00	232	4Y	Petrol	2237	4	91.00	350
3Y	Petrol	1998	4	86.00	233	4Y-EC	Petrol	2237	4	91.00	282
3Y	Petrol	1998	4	86.00	280	4Y-EC	Petrol	2237	4	91.00	289
3Y	Petrol	1998	4	86.00	287	4ZZ-FE	Petrol	1398	4	79.00	116
3Y	Petrol	1998	4	86.00	288	5E-FE	Petrol	1496	4	74.00	125
3Y-C	Petrol	1998	4	86.00	280	5E-FE	Petrol	1496	4	74.00	302
3Y-C	Petrol	1998	4	86.00	288	5E-FE	Petrol	1496	4	74.00	363
3Y-EU	Petrol	1998	4	86.00	371	5K	Petrol	1486	4	80.50	124
3ZZ-FE	Petrol	1598	4	79.00	127	5K	Petrol	1486	4	80.50	276
3ZZ-FE	Petrol	1598	4	79.00	17	5KU	Petrol	1486	4	80.50	124
4A-C	Petrol	1587	4	81.00	129	5L	Diesel	2986	4	99.50	243
4A-F	Petrol	1587	4	81.00	128	5M-GE	Petrol	2759	6	83.00	181
4A-F	Petrol	1587	4	81.00	290	5M-GE	Petrol	2759	6	83.00	192
4A-F	Petrol	1587	4	81.00	53	5M-GE	Petrol	2759	6	83.00	331
4A-FE	Petrol	1587	4	81.00	128	5M-GE	Petrol	2759	6	83.00	95
4A-FE	Petrol	1587	4	81.00	130	5S-FE	Petrol	2164	4	87.00	299
4A-FE	Petrol	1587	4	81.00	136	5S-FE	Petrol	2164	4	87.00	44
4A-FE	Petrol	1587	4	81.00	16	5S-FE	Petrol	2164	4	87.00	45
4A-FE	Petrol	1587	4	81.00	339	5S-FE	Petrol	2164	4	87.00	46
4A-FE	Petrol	1587	4	81.00	54	5S-FE	Petrol	2164	4	87.00	91
4A-FE	Petrol	1587	4	81.00	55	5S-FE	Petrol	2164	4	87.00	92
4A-FE	Petrol	1587	4	81.00	76	5VZ-FE	Petrol	3378	6	93.50	212
4A-GE	Petrol	1587	4	81.00	133	5VZ-FE	Petrol	3378	6	93.50	261
4A-GE	Petrol	1587	4	81.00	134	5VZ-FE	Petrol	3378	6	93.50	8
4A-GE	Petrol	1587	4	81.00	135	5VZ-FE	Petrol	3378	6	93.50	9
4A-GE	Petrol	1587	4	81.00	338	7A-FE	Petrol	1762	4	81.00	139
4A-GE	Petrol	1587	4	81.00	56	7A-FE	Petrol	1762	4	81.00	19
4A-GE	Petrol	1587	4	81.00	75	7A-FE	Petrol	1762	4	81.00	58



CC



9



CC



9

7A-FE	Petrol	1762	4	81.00	80
7M-GE	Petrol	2954	6	83.00	193
7M-GE	Petrol	2954	6	83.00	353
7M-GE	Petrol	2954	6	83.00	96
7M-GTE	Petrol	2954	6	83.00	194
7M-GTE	Petrol	2954	6	83.00	355
7M-GTE	Petrol	2954	6	83.00	97
VM 588 HR	Diesel	2494	5	88.00	254
VM 588 HT	Diesel	2494	5	88.00	254

TOYOTA



KW/PS



4 Runner 2.2L				01/88 →	1	BP650 (Graphite) <i>(30-028086-00)</i>	DP650 ■	GP650
4Y	2237	4	91.00	OHV	69/93			
4 Runner 2.4L				08/87 → 03/96	2	BM880 (Graphite) <i>(30-028081-00)</i>	DM883 <i>(21-28081-22/0)</i>	
22REC	2367	4	92.00	SOHC	82-87/ 112- 118			
4 Runner 2.4L TD 4x4 Diesel				08/89 → 11/95	3	BL950 (Graphite) <i>(30-026758-10)</i> BT130 (Fibre) <i>(30-028104-00)</i>		
2L-T	2446	4	92.00	SOHC	63-66/ 85-90			
4 Runner 2.7L i				11/95 →	4	BZ170 (Graphite)		
3RZ-FE	2694	4	95.00	Injection, DOHC	105- 112/ 143- 152			
4 Runner 3.0L 4x4				01/90 → 08/92	5	BS370 (Graphite) ■ BS360 (Graphite) ■	DS360	GS360
3VZ-E	2958	6	87.50	Injection, DOHC, V6	105/143			
4 Runner 3.0L Turbo-D Diesel				10/93 → 03/96	6	AG5230 (MLS), 0.95mm, 5 Holes		
1KZ-T	2982	4	96.00	SOHC	92/125			
4 Runner 3.0L V6				07/90 → 11/95	7	BS370 (Graphite) ■ → 03/94 BS360 (Graphite) ■ → 03/94	DS360 → 08/92	GS360 → 08/92
3VZ-E	2958	6	87.50	Injection, DOHC, V6	105/143			
4 Runner 3.4L				11/95 → 07/02	8			
4 Runner 3.4L i				11/95 → 07/02				
	3378	6			136/185			
5VZ-FE	3378	6	93.50		131/178			
4 Runner 3.4L i				11/95 →	9	BY460 (Graphite)		
5VZ-FE	3378	6	93.50		131/178			
4 Runner 4.7L				08/02 →	10			FF5860
4 Runner 4.7L Allrad				08/02 →				
2UZ-FE	4664	8	94.00	Injection, DOHC, V8	172- 175/ 234- 238			
Allion 1.5L				06/01 → 04/05	11			FB5750 <i>(20-29894-00/0)</i>
1NZ-FE	1497	4	75.00		78/106			
Allion 2.0L				06/01 → 04/05	12		CF5781	FF5781
Allion 2.0L 4x4				06/01 → 06/07				
1AZ-FSE	1998	4	86.00	Injection, DOHC	108- 110/ 147- 150			
Altezza 2.0L VVTi				07/01 →	13	AG9990 (MLS)		
1G-FE	1988	6	75.00	Injection, DOHC	114/155			
Altis 1.5L				11/01 → 05/04	14			FB5750 <i>(20-29894-00/0)</i>
1NZ-FE	1497	4	75.00		78/106			
Aurion 2.0L				03/06 →	15		CF5781	FF5781
	1998	4			114/155			
1AZ-FSE	1998	4	86.00	Injection, DOHC	108- 110/ 147- 150			

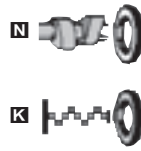
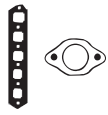

BL950



BM880



BP650



BS360



BS370



BT130



BY460



BZ170



JN551



JN712

	JC615 (x2) [149]	JN551		PA385 (x8)	NJ344 42x60x7mm, NBR NJ360 80x100x8.5mm, MVQ	
HBS386 [22-71022B]						
HBS425 [22-71030B] M11x1.25x105mm (x10)	JE013 (x2) [149]	JN954		PA425 (x8) (50.306560-50)	NJ200 48x68x7mm, NBR NK055 88x106x8.7mm, FPM	
HBS397 [22-71024B]	JC838	JN712		PA136 (x6) PB344 (x6)	NK180 42x55x8mm, MVQ NK050 40x55x6mm, ACM NK015 91x110x8.5mm, MVQ	
HBS209 [22-71014B] M12x1.25x127mm (x18)					NK251 50x68x9mm	
HBS397 [22-71024B] 01/95→	JC838	JN712 (x2)		PA136 (x6) PB344 (x6)	NK180 (x2) 42x55x8mm, MVQ NK050 40x55x6mm, ACM NK015 91x110x8.5mm, MVQ	
	JA5058					
HBS394 (x16) [22-71028B]	JA5058					

TOYOTA



KW/PS



Avensis 1.6L						09/97 → 10/00	16	BV370 (Graphite)	CD5360	
4A-FE	1587	4	81.00	Leanburn Injection, DOHC	84/114					
Avensis 1.6L VVT-i						10/00 → 02/03	17	AB5760 (MLS) (30-029887-00)	CB5760■ (21-29887-20/0)	FB5760 (20-29887-00/0)
3ZZ-FE	1598	4	79.00		81/110					
Avensis 1.8L						04/03 →	18	AB5760 (MLS) (30-029887-00)	CB5760■ (21-29887-20/0)	FB5760 (20-29887-00/0)
Avensis 1.8L VVT-i						10/00 → 02/03				
1ZZ-FE	1794	4	79.00	DOHC	92/95/ 105					
Avensis 1.8L						09/97 → 10/00	19	BV360 (MLS)	CG5490	
7A-FE	1762	4	81.00	MPi, DOHC	81/110					
Avensis 1.9 D Diesel						10/97 → 05/98	20			FG7650 ▲
Avensis 2.0L D Diesel						10/97 → 05/98				
2CT	1975	4	86.00	SOHC	62/84					
Avensis 1.9 D Diesel						09/02 → 02/03	21	AD5370 (MLS), 1mm, 1 Notch	CD5370▲	FG7480 ▲
Avensis 2.0L D-4D Diesel						10/99 → 02/03		AG7480 (MLS), 1.05mm, 2 Notches		
Avensis Verso 2.0L D-4D Diesel						08/01 →		1CDFTV		
1CD-FTV	1995	4	82.20	Direct Injection, DOHC	66-85/ 90-116		AG7490 (MLS), 1.1mm, 3 Notches	1CDFTV		
							AG7500 (MLS), 1.15mm, 4 Notches	1CDFTV		
							AG7510 (MLS), 1.2mm, 5 Notches	1CDFTV		
Avensis 2.0L						04/03 →	22	AF5780 (MLS)	CF5781	FF5781
Avensis 2.0L VVT-i						10/00 → 02/03				
1AZ-FSE	1998	4	86.00	Injection, DOHC	108- 110/ 147- 150					
Avensis 2.0L						09/97 → 10/00	23	AD5330 (MLS)	CD5330	FD5330
3S-FE	1998	4	86.00	Injection, DOHC	88-98/ 120- 133					
Avensis 2.0L D-4D Diesel						04/03 →	24	AD5370 (MLS), 1mm, 1 Notch	CD5370▲	FG7480 ▲
Avensis 2.0L D-4D Diesel						04/03 →		AG7480 (MLS), 1.05mm, 2 Notches		
1CD-FTV	1995	4	82.20	Direct Injection, DOHC	66-85/ 90-116		1CD-FTV	1CD-FTV		
							AG7490 (MLS), 1.1mm, 3 Notches	1CD-FTV		
							AG7500 (MLS), 1.15mm, 4 Notches	1CD-FTV		
							AG7510 (MLS), 1.2mm, 5 Notches	1CD-FTV		
Avensis 2.0L TD Diesel						09/97 → 02/03	25	AG7670 (MLS)	CD5340	FG7650 ▲
2C-TE	1975	4	86.00	Indirect Injection, SOHC	66/89		2C-TE	AD5340 (MLS), 1.25mm, 1 Hole (30-030183-00)		
							AG5240 (Steel Elastomer), 1.45mm, 3 Holes			

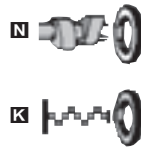
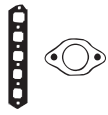

AB5760



BV360



BV370



JD176



JD194

HBS203 Ⓞ (22-71008B) M10x1.25x90mm (x5) M10x1.25x108mm (x5)	JD176 ■					
HBS385 Ⓞ (22-71021B)	JD5243 ■ (31-029889-00) JD5160 ■ (31-029890-00) (MLS) Ⓞ KK5495	JM5073 (50-029888-00)		PA5019 ■ (x8) (50-319497-00) PA5020 ■ (x8) (50-319496-00)	NA5089 ■ 38x50x8mm, NBR (50-319498-00) NA5090 ■ 76x94x8.5mm, FPM (50-319499-00)	
HBS385 Ⓞ (22-71021B)	JD5243 ■ (31-029889-00) JD5160 ■ (31-029890-00) (MLS)	JM5073 (50-029888-00)		PA5019 ■ (x8) (50-319497-00) PA5020 ■ (x8) (50-319496-00)	NA5089 ■ 38x50x8mm, NBR (50-319498-00) NA5090 ■ 76x94x8.5mm, FPM (50-319499-00)	
HBS203 Ⓞ (22-71008B) M10x1.25x90mm (x5) M10x1.25x108mm (x5)		HM5235 ■				
HBS314 Ⓞ (22-71019B) M11x1.25x160mm (x8) M12x1.25x104mm (x10)	JD5901 ■	JM5148				
HBS441 [209] (22-71023B) M11x1.50x162.0mm (x10)	JD5171 ■ (MLS) 0,4mm	JM7022				
HBS200 Ⓞ (22-71005B) M10x1.25x94.5mm (x10)	JD194 ■ Ⓞ JE094 Ⓞ JF087 (x2)	HM5276 ■ (Rubber)		PA425 (x16) (50-306560-50)	NJ347 38x50x8mm, NBR NK214 ■ 35x63x16.5mm NJ344 ■ 42x60x7mm, NBR NJ354 ■ 85x105x10mm, MVQ	NJ693 [70] NK215 [38]
HBS314 Ⓞ (22-71019B) M11x1.25x160mm (x8) M12x1.25x104mm (x10)	JD5901 ■	JM5148				
HBS042 Ⓞ (22-71001B) M11x1.25x145mm (x10) M11x1.25x123mm (x8)		JM5146				NK215 [38]







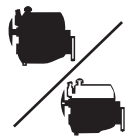



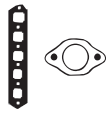

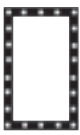

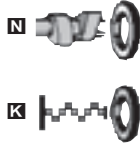



TOYOTA



KW/PS



Avensis Verso 2.0L VVT-i						08/01 →	26	AF5780 (MLS)	CF5780	EG6310
1AZ-FE	1998	4	86.00	Injection, DOHC		110/150				
Avensis Verso 2.4L VVTi GLS						10/03 →	27	AF5840 (MLS), 0,4mm		
2AZ-FE	2362	4	88.50	Injection, DOHC		112- 115/ 152- 156				
Aygo 1.0L						07/05 →	28	AG9310 (MLS)	CG9310	EG9310
1KR-FE	998	3	71.00	DOHC		50/68				
Aygo 1.4L HDI Diesel						07/05 →	29			
	1398	4				40/54				
bB 1.5L						03/00 →	30			FB5750 (20-29894-00/0)
1NZ-FE	1497	4	75.00			78/106				
Belta 1.0L						09/05 →	31	AG9310 (MLS)	CG9310	EG9310
1KR-FE	998	3	71.00	DOHC		50/68				
Belta 1.5L						09/05 →	32			FB5750 (20-29894-00/0)
1NZ-FE	1497	4	75.00			78/106				
Caetano 4.0L optima Diesel						08/87 →12/89	33	BR890 (Fibre)	DR890	GR890
1ZHT	3980	6	91.00	Turbo		100/136				
Caldina 2.0L						10/01 →	34		CF5781	FF5781
1AZ-FSE	1998	4	86.00	Injection, DOHC		108- 110/ 147- 150				
Caldina 2.0L TD Diesel						06/94 →09/97	35			FG7650 ▲
2C	1974	4	86.00			51-54/ 69-73				
Camry 1.8L Camry 1.8L i						02/83 →10/86 10/86 →08/88	36	BK670 (Graphite)	DK670	GK671
1S-L	1832	4	80.50			66-74/ 90-101				
Camry 1.8L Turbo-D Diesel						11/83 →01/88	37	AB5000 (Graphite) (30-029229-00)	CB5001	FB5001
1CTL	1839	4	83.00	SOHC		54/73				
Camry 2.0L Camry 2.0L GLi Camry 2.0L Gli 16V Camry 2000 ZX						11/86 →05/91 10/87 →07/88 11/86 →05/91 06/91 →09/97	38	BR250 (Graphite) (30-028087-00) →08/89 BS970 (Graphite) (30-028103-00) 09/89 →	CD5330 DR250 (21-28087-20/0) →08/89	FD5330 GR250 →08/89
3S-FE	1998	4	86.00	Injection, DOHC		88-98/ 120- 133				











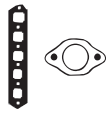

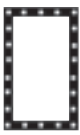

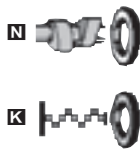



								 BK670  BR250  BR890  BS970  JC402  JC444  JC576  JC842  JD194  JN469  JN532  JN655  JN705
HBS441 [209] (22-71023B) M11x1.50x162.0mm (x10) 01/00 →	JD5170 ■ JD5171 ■ (MLS) 0,4mm	JM7036 (Rubber)						
	JD5845 ■ (NBR) JD5846 ■ (MLS) JD5863 ■ (Steel Elastomer)	JM7042 (ACM)			NA5260 38x50x6mm			
HBS359 ⊕ (22-15018B) M11x1.50x150mm (x10)								
	JD5845 ■ (NBR) JD5846 ■ (MLS) JD5863 ■ (Steel Elastomer)	JM7042 (ACM)			NA5260 38x50x6mm			
		JN705		PA310 (x12)	NJ239 ■ 50x72x12mm, NBR NJ240 ■ 95x115x12mm, MVQ			
	JC402 ⊕ JE106	JN469	JH5098	KJ466 (x8)	NJ347 38x50x8mm, NBR NJ344 ■ 42x60x7mm, NBR NJ354 ■ 85x105x10mm, MVQ	NJ963 [70]		
HBS042 ⊕ (22-71001B) M11x1.25x145mm (x10) M11x1.25x123mm (x8)	JC576 ■ JC444 ■ ⊕ JE619	JN532		PA136 (x8)	NJ347 38x50x8mm, NBR →01/85 NJ706 37.5x50x6mm, ACM 02/85 → NJ344 ■ 42x60x7mm, NBR NJ346 ■ 90x110x8.5mm, MVQ			
HBS200 ⊕ (22-71005B) M10x1.25x94.5mm (x10)	JD194 ■ JC842 ■ →08/89 ⊕ JF087 (x2) ⊕ JE094 09/89 →	JN655 (50-028189-00) (Rubber) HM5276 ■ (Rubber)	JH5098	PA425 (x16) (50-306560-50)	NJ347 38x50x8mm, NBR NK214 ■ 35x63x16.5mm NJ344 ■ 42x60x7mm, NBR NJ354 ■ 85x105x10mm, MVQ	NJ693 [70]		



KW/PS



Camry 2.0L						04/86 → 01/88	39	BL350 (Graphite)	DL350	
Camry 2.0L GII						03/83 → 10/86				
2S-ELC	1995	4	84.00	SOHC		72-73/ 98-99				
2S-E	1995	4	84.00	SOHC		79/107				
2S-EL	1995	4	84.00			88.5/ 120				
Camry 2.0L GL Turbo Diesel						08/85 → 10/86	40	BR580 (Graphite) (30-028092-00)	DR580	
2C-TL	1974	4	86.00	SOHC, Turbo		63/86				
Camry 2.0L TD Diesel						11/88 → 09/99	41	BX020 (MLS), 1.35mm	DX020	FG7650 ▲ GX020
Camry 2.0L Turbo-D Diesel						11/86 → 05/91				
2C-T	1975	4	86.00	SOHC		62/84				
Camry 2.0L TD Diesel						11/86 → 05/91	42	BR580 (Graphite) (30-028092-00) → 12/88 BX020 (MLS), 1.35mm 01/89 →	DR580 → 12/88 DX020 01/89 →	FG7650 ▲ GX020 01/89 →
2C-T	1975	4	86.00	SOHC		62/84				
Camry 2.0L VVTi						08/01 →	43	AF5780 (MLS)	CF5780	EG6310
1AZ FE	1998	4	86.00	Injection, DOHC		110/150				
Camry 2.2L						11/00 → 11/01	44	BS970 (Graphite) (30-028103-00)	DS970 (21-28103-20/0)	GS970
5S-FE	2164	4	87.00	Injection, DOHC		93-103/ 126- 140				
Camry 2.2L						06/91 → 08/96	45	BS970 (Graphite) (30-028103-00)	DS970 (21-28103-20/0)	GS970
5S-FE	2164	4	87.00	Injection, DOHC		93-103/ 126- 140				
Camry 2.2L						08/96 → 11/01	46	BS970 (Graphite) (30-028103-00)	DS970 (21-28103-20/0)	GS970
5S-FE	2164	4	87.00	Injection, DOHC		93-103/ 126- 140				
Camry 2.4L VVT-i						11/01 →	47	AF5840 (MLS), 0,4mm	CF5840	
2AZ-FE	2362	4	88.50	Injection, DOHC		112- 115/ 152- 156				
Camry 2.5L V6 GXI						02/88 → 05/91	48			
2VZ-FE	2507	6	87.50	DOHC, V6		118/160				
Camry 3.0L						06/91 → 08/96	49	BS300 (Graphite) ☒ BS290 (Graphite) ☒ (30-028098-00)	DS292	
3VZ-FE	2959	6	87.50	Injection, DOHC, V6		138/188				
Camry 3.0L 24V						08/96 → 11/01	50	AG9100 (MLS) ☒ BZ350 (Fibre), 1.3mm ☒ AG9090 (MLS) ☒ BZ340 (Fibre), 1.3mm ☒	DZ350	
Camry 3.0L V6						04/00 → 11/01				
1MZ-FE	2995	6	87.50	Injection, DOHC, V6		135- 150/ 184- 204				

								
		JC402 ⊗JE012 [149]	JN469	JH5098	KJ466 (x8)	☒ NJ347 38x50x8mm, NBR ☒ NJ344☒ 42x60x7mm, NBR		 BL350
HBS042⊗ [22-71001B] M11x1.25x145mm (x10) M11x1.25x123mm (x8)	JC576☐ JC444☒ ⊗JE619	JN532		PA136 (x8)	☒ NJ706 37.5x50x6mm, ACM ☒ NJ346☒ 90x110x8.5mm, MVQ			 BR580
HBS042⊗ [22-71001B] M11x1.25x145mm (x10) M11x1.25x123mm (x8)	JC444☒ ⊗JF058	JN532		PA136 (x8)	☒ NJ706 37.5x50x6mm, ACM ☒ NJ344☒ 42x60x7mm, NBR ☒ NJ346☒ 90x110x8.5mm, MVQ		NJ654 [70]	 BS290
HBS042⊗ [22-71001B] M11x1.25x145mm (x10) M11x1.25x123mm (x8)	JC576☐ →12/88 JC444☒ ⊗JE619 →12/88 ⊗JF058 01/89→	JN532		PA136 (x8)	☒ NJ706 37.5x50x6mm, ACM ☒ NJ344☒ 42x60x7mm, NBR ☒ NJ346☒ 90x110x8.5mm, MVQ		NJ654 [70]	 BS300
HBS441 [209] [22-71023B] M11x1.50x162.0mm (x10) 01/00→	JD5170☐ JD5171☒ (MLS) 0,4mm	JM7036 (Rubber)						 BS970
HBS200⊗ [22-71005B] M10x1.25x94.5mm (x10)	JD194☐ JD112☒ ⊗JF087 (x2)	JN655 (50-028189-00) (Rubber) HM5276☒ (Rubber)	JH5098	PA425 (x16) (50-306560-50)	☒ NJ347 38x50x8mm, NBR ☒ NJ344☒ 42x60x7mm, NBR ☒ NJ354☒ 85x105x10mm, MVQ			 BX020
HBS200⊗ [22-71005B] M10x1.25x94.5mm (x10)	JD194☐ JD112☒ ⊗JF087 (x2) 03/92→08/94	JN655 (50-028189-00) (Rubber) HM5276☒ (Rubber)	JH5098	PA425 (x16) (50-306560-50)	☒ NJ347 38x50x8mm, NBR ☒ NJ344☒ 42x60x7mm, NBR ☒ NJ354☒ 85x105x10mm, MVQ			 JC402
HBS200⊗ [22-71005B] M10x1.25x94.5mm (x10)	JD194☐ JD112☒ ⊗JF087	JN655 (50-028189-00) (Rubber) HM5276☒ (Rubber)	JH5098	PA425 (x16) (50-306560-50)	☒ NJ347 38x50x8mm, NBR ☒ NJ344☒ 42x60x7mm, NBR ☒ NJ354☒ 85x105x10mm, MVQ			 JC444
HBS441 [209] [22-71023B] M11x1.50x162.0mm (x10)								 JC576
HBS394 (x16) [22-71028B]								 JD112
HBS394 (x16) [22-71028B]		JN792 (x2)		PB281 ☐ (x12)	☒ NJ347 (x2) 38x50x8mm, NBR			 JD194
		HM5242☒ (NBR)						 JN469











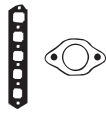

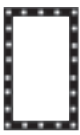

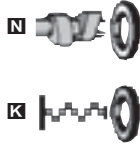

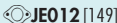

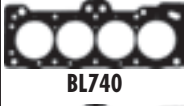

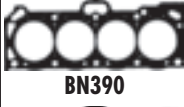
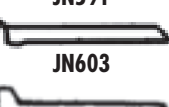
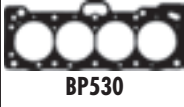
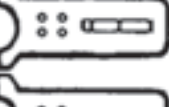
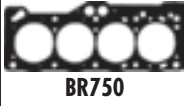

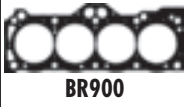

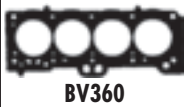
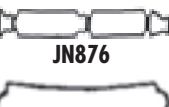
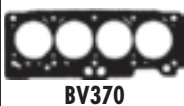



TOYOTA

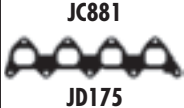

KW/PS



Carina 1.6L		10/83 → 11/87		51	BL740 (Graphite) →08/85 BP530 (Graphite) (30-028085-00) 08/85 →	DL742 →08/85 DP530 08/85 →	GL741 GL742 (20-26743-02/0) →08/85 GP530 08/85 →
Carina 1.6L		10/83 → 11/87		52	BL740 (Graphite)	DL742	GL741
Carina 1.6L		12/87 → 08/90		53	BR750 (Graphite) (30-028093-00)	DR751	
Carina 1.6L		12/87 → 03/92		54	BR750 (Graphite) (30-028093-00)	DR750 (21-28093-20/0) →12/88 DR751 01/89 →	GR750 (20-28093-00/0) →12/88 GR751 01/89 →
Carina 1.6L		01/93 → 09/97		55	BV370 (Graphite)	DV370 (21-28107-20/0)	
Carina 1.6L 16V		12/94 → 09/97					
Carina 1.6L GLi		04/92 → 09/97					
Carina 1.6L i		02/95 → 09/97					
Carina 1.6L		01/88 → 06/92		56	BN390 (Graphite) (30-028083-00) →05/89 BR900 (Graphite) 05/89 →	DN390 →05/89 DR901 05/89 →	GN390 (20-28083-00/0) →05/89 GR901 05/89 →
Carina 1.6L GT 16V		01/83 → 12/87		57	BN390 (Graphite) (30-028083-00)	DN392 →05/84 DN390 06/84 →	GN390 (20-28083-00/0) 06/84 →
Carina 1.8L		01/95 → 09/97		58	BV360 (MLS)	DV360 (21-28106-20/0)	GV360
Carina 1.8L i		02/95 → 09/97					
Carina 1.8L i 16V		01/95 → 09/97					
Carina 1.8L		03/77 → 11/84		59	BC990 (Graphite) (30-028067-00)	DC993 ■ (21-28067-20/0) →08/80 DC994 08/80 →	GC993 →08/80 GC994 08/80 →

								
		 JE012 [149]	JN356 →08/85 JN591 08/85→		KJ722 (x8)	NJ353 35x49x6mm, NBR NJ349 32.5x46x6mm, NBR NJ001 70x92x8.5mm, MVQ		 BC990  JN410
								 BL740  JN591
								 BN390  JN603
								 BP530  JN604
								 BR750  JN604
HBS203 [22-71008B] M10x1.25x90mm (x5) M10x1.25x108mm (x5)		JN706	JH5099					 BR900  JN706
HBS203 [22-71008B] M10x1.25x90mm (x5) M10x1.25x108mm (x5)	JC880 JC881 JE015 (x2) [149]	JN706	JH5099	PA425 (x16) (50-306560-50)	NJ353 (x2) 35x49x6mm, NBR NJ349 32.5x46x6mm, NBR NJ001 70x92x8.5mm, MVQ			 BV360  JN876
HBS203 [22-71008B] M10x1.25x90mm (x5) M10x1.25x108mm (x5)	JD175 JD5771 JD176	JN904	JH5099	PA425 (x16) (50-306560-50)	NJ353 (x2) 35x49x6mm, NBR NJ349 32.5x46x6mm, NBR NJ001 70x92x8.5mm, MVQ			 BV370  JN904
	JC578 →05/89 JC879 05/89→ JC579 JE015 (x2) [149] →05/89 JE106 →05/89 JE619 (x2) →05/89 JF058 (x2) 05/89→ JF087 (x2) 05/89→	JN603 (x2) JN604 →05/89 JN876 05/89→		PA425 (x16) (50-306560-50)	NJ353 (x2) 35x49x6mm, NBR NJ349 32.5x46x6mm, NBR NJ001 70x92x8.5mm, MVQ			 JA053  JH041
	JC578 JC579 JE106	JN603 (x2) JN604		PA425 (x16) (50-306560-50)	NJ353 (x2) 35x49x6mm, NBR NJ349 32.5x46x6mm, NBR NJ001 70x92x8.5mm, MVQ			 JB949  JC578  JC579  JC879  JC880  JC881  JD175  JD176
HBS203 [22-71008B] M10x1.25x90mm (x5) M10x1.25x108mm (x5)	JD175 JD5771 JD176	JN904		PA425 (x16) (50-306560-50)	NJ353 35x49x6mm, NBR NJ001 70x92x8.5mm, MVQ			 JM054  JN356
	JB949 JA053 JB950 08/80→ JE015 [149] JE037 JE012 (x2) [149] 08/80→	JM054 →08/80 JN410 08/80→	JH041	KJ466 (x8)	NJ102 38.5x58x11mm, NBR NJ044 75x100x13mm, MVQ			



KW/PS



Carina 1.8L D Diesel					05/83 →	60			DL300	FB5000
1C-L	1839	4	83.00	SOHC	47/64	BL300 (Graphite) (30-026751-10) →07/83 AB5000 (Graphite) (30-029229-00) 07/83 →05/85 BR580 (Graphite) (30-028092-00) 05/85 →04/87 BX010 (MLS) 05/85 →		→07/83 CB5000 07/83 →05/85 DX010 05/85 →	07/83 →05/85 GX010 05/85 →	
Carina 1.8L GLI					10/83 →11/87	61			DK670	
1S-L	1832	4	80.50		66-74/ 90-101	BK670 (Graphite)				
1S-EL	1832	4	80.50		74/100					
Carina 2.0L					01/93 →09/97	62			CD5330	FD5330
Carina 2.0L GLI					04/92 →09/97		BS970 (Graphite) (30-028103-00) →11/96 AD5330 (MLS) 12/96 →			12/96 →
3S-FE	1998	4	86.00	Injection, DOHC	88-98/ 120- 133					
Carina 2.0L					12/87 →04/92	63			DR250	
3S-FE	1998	4	86.00	Injection, DOHC	88-98/ 120- 133	BR250 (Graphite) (30-028087-00)		(21-28087-20/0)		
Carina 2.0L D Diesel					02/84 →06/93	64				
2C-L	1975	4	86.00	Indirect Injection, SOHC	50-54/ 68-73	BX020 (MLS), 1.35mm				
Carina 2.0L D Diesel					03/88 →01/96	65			DR581	GR581
Carina 2.0L ED Diesel					08/92 →01/96		BR580 (Graphite) (30-028092-00)		(21-28092-21/0)	
2C	1974	4	86.00		51-54/ 69-73					
Carina 2.0L GLi					12/87 →03/92	66			DR250	GR250
3S-FE	1998	4	86.00	Injection, DOHC	88-98/ 120- 133	BR250 (Graphite) (30-028087-00) →08/89 BS970 (Graphite) (30-028103-00) 09/89 →		(21-28087-20/0) →08/89 CD5330 09/89 →	→08/89 FD5330 09/89 →	
Carina 2.0L GLI					01/93 →09/97	67			CD5330	FD5330
3S-FE	1998	4	86.00	Injection, DOHC	88-98/ 120- 133	BS970 (Graphite) (30-028103-00) →11/96 AD5330 (MLS) 12/96 →				
Carina 2.0L GTi					04/92 →02/94	68				
Carina 2.0L GTi 16V					03/94 →09/97		BS060 (Graphite)			
3S-GE	1998	4	86.00	Injection, DOHC	115- 129/ 156- 175					
Carina 2.0L i					12/92 →09/97	69			CD5330	FD5330
3S-FE	1998	4	86.00	Injection, DOHC	88-98/ 120- 133	BS970 (Graphite) (30-028103-00) →11/96 AD5330 (MLS) 12/96 →				

		JC576 JC399 JF087	JN532		PA136 (x8)	<input checked="" type="checkbox"/> NJ347 38x50x8mm, NBR →01/85 <input checked="" type="checkbox"/> NJ706 37.5x50x6mm, ACM 02/85→ <input checked="" type="checkbox"/> NJ344 42x60x7mm, NBR <input checked="" type="checkbox"/> NJ346 90x110x8.5mm, MVQ		
				JH5098				
HBS200 (22-71005B) M10x1.25x94.5mm (x10)	JD194 JE094 JF087 (x2)	HM5276 (Rubber)	JH5098	PA425 (x16) (50-306560-50)	<input checked="" type="checkbox"/> NJ347 38x50x8mm, NBR <input checked="" type="checkbox"/> NJ344 42x60x7mm, NBR <input checked="" type="checkbox"/> NJ354 85x105x10mm, MVQ	NJ693 [70]		
HBS200 (22-71005B) M10x1.25x94.5mm (x10)		HM5276 (Rubber)	JH5098		<input checked="" type="checkbox"/> NK214 35x63x16.5mm			
HBS042 (22-71001B) M11x1.25x145mm (x10) M11x1.25x123mm (x8)								
HBS042 (22-71001B) M11x1.25x145mm (x10) M11x1.25x123mm (x8)	JC576 JC399 JE015 [149] JE106	JN532		PA136 (x8)	<input checked="" type="checkbox"/> NJ706 37.5x50x6mm, ACM <input checked="" type="checkbox"/> NJ344 42x60x7mm, NBR <input checked="" type="checkbox"/> NJ346 90x110x8.5mm, MVQ	NJ654 [70] NK215 [38]		
HBS200 (22-71005B) M10x1.25x94.5mm (x10)	JD194 JC842 →08/89 JF087 (x2) JE094 09/89→	JN655 (50-028189-00) (Rubber) HM5276 (Rubber)	JH5098	PA425 (x16) (50-306560-50)	<input checked="" type="checkbox"/> NJ347 38x50x8mm, NBR <input checked="" type="checkbox"/> NK214 35x63x16.5mm <input checked="" type="checkbox"/> NJ344 42x60x7mm, NBR <input checked="" type="checkbox"/> NJ354 85x105x10mm, MVQ	NJ693 [70]		
HBS200 (22-71005B) M10x1.25x94.5mm (x10)	JE094 JF087	JN655 (50-028189-00) (Rubber) HM5276 (Rubber)	JH5098	PA425 (x16) (50-306560-50)	<input checked="" type="checkbox"/> NJ347 38x50x8mm, NBR <input checked="" type="checkbox"/> NK214 35x63x16.5mm <input checked="" type="checkbox"/> NJ344 42x60x7mm, NBR <input checked="" type="checkbox"/> NJ354 85x105x10mm, MVQ	NJ693 [70]		
HBS198 (22-71003B) M10x1.25x93mm (x10)	JC842	JN768 JN917	JH5098	PA425 (x8) (50-306560-50) PB281 (x8) →08/93	<input checked="" type="checkbox"/> NJ353 (x2) 35x49x6mm, NBR <input checked="" type="checkbox"/> NJ344 42x60x7mm, NBR	NJ693 [70]		
HBS200 (22-71005B) M10x1.25x94.5mm (x10)	JD194 JE094 JF087 (x2)	JN655 (50-028189-00) (Rubber) HM5276 (Rubber)	JH5098	PA425 (x16) (50-306560-50)	<input checked="" type="checkbox"/> NJ347 38x50x8mm, NBR <input checked="" type="checkbox"/> NJ344 42x60x7mm, NBR <input checked="" type="checkbox"/> NJ354 85x105x10mm, MVQ	NJ693 [70]		

TOYOTA



KW/PS



Carina 2.0L TD Diesel				01/96 → 09/97		70	AD5350 (MLS), 1.25mm, 1 Hole AG7650 (MLS), 1.35mm, 2 Holes →08/97 2C-T AG7660 (MLS), 1.45mm, 3 Holes →08/97 2C-T	DX020	GX020
2C-T	1975	4	86.00	SOHC	62/84				
Carina 2.0L TD Diesel				09/97 →		71			
2C-TE	1975	4	86.00	Indirect Injection, SOHC, Turbo Intercooled	66/89				
Celica 1.6L				01/77 → 12/85		72		DD061 ■	GD061
2TGEU	1588	4	85.00	DOHC					
Celica 1.6L GT				08/87 → 08/89		73	BN390 (Graphite) (30-028083-00)	DN392 →05/84 DN390 06/84 →	GN390 (20-28083-00/0) 06/84 →
Celica 1.6L GT 16V				09/85 → 08/89					
4A-GELC	1587	4	81.00		85/116				
4A-GEL	1587	4	81.00		85-91/ 116- 124				
Celica 1.6L GT 16V				01/83 → 12/87		74	BN390 (Graphite) (30-028083-00)	DN390	GN390 (20-28083-00/0)
4A-GEU	1587	4	81.00	DOHC					
Celica 1.6L GT 16V				04/86 → 08/89		75	BN390 (Graphite) (30-028083-00)	DN392 →05/84 DN390 06/84 →	GN390 (20-28083-00/0) 06/84 →
Celica Coupe 1.6L				12/83 → 10/86					
4A-GEL	1587	4	81.00		85-91/ 116- 124				
4A-GE	1587	4	81.00	Injection, DOHC	85-92/ 116- 125				
Celica Coupe 1.6L STI				10/89 → 01/94		76	BR750 (Graphite) (30-028093-00)	DR751	
4A-FE	1587	4	81.00	Leanburn Injection, DOHC	84/114				
Celica 1.8L				10/82 → 10/86		77	BK670 (Graphite)	DK670	GK671
1S	1832	4	80.50		66/89				
Celica Coupe 1.8L 16V TS				11/99 →		78	AG9110 (MLS), 0.4mm	CG9110	EG6290
2ZZ-GE	1796	4	82.00	Injection	141/192				
Celica Coupe 1.8L 16V VT-i				11/99 →		79	AB5760 (MLS) (30-029887-00)	CB5760 ■ (21-29887-20/0)	FB5760 (20-29887-00/0)
1ZZ-FE	1794	4	79.00	DOHC	92/95/ 105				
Celica Coupe 1.8L i 16V				11/93 → 11/99		80	BV360 (MLS)	DV360 (21-28106-20/0)	GV360
7A-FE	1762	4	81.00	MPi, DOHC	81/110				
Celica 2.0L				01/87 → 08/90		81	BR330 (Graphite) (30-028090-00)	DR330	GR330
Celica 2.0L GT				08/85 → 08/89					
Celica Convertible 2.0L GT				10/86 → 08/90					
3S-GEL	1998	4	86.00	DOHC	110/150				
Celica 2.0L				01/82 → 12/87		82	BL350 (Graphite)	DL350	
2S	1995	4	84.00	SOHC	69-88/ 94-120				

HBS042 ⊙ [22-71001B] M11x1.25x145mm (x10) M11x1.25x123mm (x8)	JC444 ■ ⊙JF058	JM5146		PA136 (x8)	NJ706 37.5x50x6mm, ACM NJ344 ■ 42x60x7mm, NBR NJ346 ■ 90x110x8.5mm, MVQ	NJ654 [70] NK215 [38]	AB5760 BK670 BL350 BN390 BR330 BR750 BV360 JA053 JC402 JC444 JC576 JC578 JC579 JC840 JC841 JC842 JD175 JD176 JN469 JN603 JN904 JH041	JN629 JN630 JN904 JH041
HBS042 ⊙ [22-71001B] M11x1.25x145mm (x10) M11x1.25x123mm (x8)	JC576 ■			PA136 (x8)	NJ706 37.5x50x6mm, ACM NJ344 ■ 42x60x7mm, NBR NJ346 ■ 90x110x8.5mm, MVQ		BR330 BR750 BV360 JA053 JC402 JC444 JC576 JC578 JC579 JC840 JC841 JC842 JD175 JD176 JN469 JN603 JN904 JH041	
	JA053 ■ ⊙JE012 (x2) [149] ⊙JE037		JH041	KJ469 (x8)	NJ102 ■ 38.5x58x11mm, NBR NJ044 ■ 75x100x13mm, MVQ		BR330 BR750 BV360 JA053 JC402 JC444 JC576 JC578 JC579 JC840 JC841 JC842 JD175 JD176 JN469 JN603 JN904 JH041	
HBS203 ⊙ [22-71008B] M10x1.25x90mm (x5) M10x1.25x108mm (x5)	JC578 ■ JC579 ■ ⊙JE106	JN603 (x2) →05/84 JN604 06/84→	JH5099	PA425 (x16) (50-306560-50)	NJ353 (x2) 35x49x6mm, NBR NJ349 ■ 32.5x46x6mm, NBR NJ001 ■ 70x92x8.5mm, MVQ		BR330 BR750 BV360 JA053 JC402 JC444 JC576 JC578 JC579 JC840 JC841 JC842 JD175 JD176 JN469 JN603 JN904 JH041	
	JC578 ■ JC579 ■ ⊙JE106	JN603 (x2) JN604 01/84→		PA425 (x16) (50-306560-50)	NJ353 35x49x6mm, NBR NJ349 ■ 32.5x46x6mm, NBR NJ001 ■ 70x92x8.5mm, MVQ		BR330 BR750 BV360 JA053 JC402 JC444 JC576 JC578 JC579 JC840 JC841 JC842 JD175 JD176 JN469 JN603 JN904 JH041	
HBS203 ⊙ [22-71008B] M10x1.25x90mm (x5) M10x1.25x108mm (x5)	JC578 ■ JC579 ■ ⊙JE106	JN603 (x2) →05/84 JN604 06/84→	JH5099	PA425 (x16) (50-306560-50)	NJ353 35x49x6mm, NBR NJ349 ■ 32.5x46x6mm, NBR NJ001 ■ 70x92x8.5mm, MVQ		BR330 BR750 BV360 JA053 JC402 JC444 JC576 JC578 JC579 JC840 JC841 JC842 JD175 JD176 JN469 JN603 JN904 JH041	
HBS203 ⊙ [22-71008B] M10x1.25x90mm (x5) M10x1.25x108mm (x5)			JH5099				BR330 BR750 BV360 JA053 JC402 JC444 JC576 JC578 JC579 JC840 JC841 JC842 JD175 JD176 JN469 JN603 JN904 JH041	
	JC402 ⊙JE012 [149] ⊙JE106 01/83→10/83	JN469		KJ466 (x8)	NJ347 38x50x8mm, NBR NJ344 ■ 42x60x7mm, NBR NJ354 ■ 85x105x10mm, MVQ	NJ963 [70]	BR330 BR750 BV360 JA053 JC402 JC444 JC576 JC578 JC579 JC840 JC841 JC842 JD175 JD176 JN469 JN603 JN904 JH041	
HBS385 ⊙ [22-71021B]	JD5243 ■ (31-029889-00) JD5160 ■ (31-029890-00) (MLS) ⊙KK5495	JM5073 (50-029888-00)		PA5019 ■ (x8) (50-319497-00) PA5020 ■ (x8) (50-319496-00)	NA5089 ■ (x8) 38x50x8mm, NBR (50-319498-00) NA5090 ■ (x8) 76x94x8.5mm, FPM (50-319499-00)		BR330 BR750 BV360 JA053 JC402 JC444 JC576 JC578 JC579 JC840 JC841 JC842 JD175 JD176 JN469 JN603 JN904 JH041	
HBS203 ⊙ [22-71008B] M10x1.25x90mm (x5) M10x1.25x108mm (x5)	JD175 ■ JD176 ■	JN904		PA425 (x16) (50-306560-50)	NJ353 35x49x6mm, NBR NJ001 ■ 70x92x8.5mm, MVQ		BR330 BR750 BV360 JA053 JC402 JC444 JC576 JC578 JC579 JC840 JC841 JC842 JD175 JD176 JN469 JN603 JN904 JH041	
HBS198 ⊙ [22-71003B] M10x1.25x93mm (x10)	JC840 ■ JC841 ■ JC842 ■ ⊙JE015 (x2) [149] ⊙JE619	JN629 (50-028187-00) →Eng.8xxxxxx JN630 Eng.9xxxxxx→	JH5098	PA425 (x8) (50-306560-50) PB281 (x8)	NJ353 (x2) 35x49x6mm, NBR NJ344 ■ 42x60x7mm, NBR NJ354 ■ 85x105x10mm, MVQ	NJ963 [70]	BR330 BR750 BV360 JA053 JC402 JC444 JC576 JC578 JC579 JC840 JC841 JC842 JD175 JD176 JN469 JN603 JN904 JH041	
	JC402 ⊙JE012 [149]	JN469		KJ466 (x8)	NJ347 38x50x8mm, NBR NJ344 ■ 42x60x7mm, NBR		BR330 BR750 BV360 JA053 JC402 JC444 JC576 JC578 JC579 JC840 JC841 JC842 JD175 JD176 JN469 JN603 JN904 JH041	











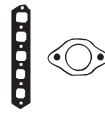













TOYOTA



KW/PS



Celica 2.0L 01/82 → 83						BK680 (Graphite) (30-028077-00)	DK680	
1G-E	1988	6	75.00	SOHC	80/109			
Celica 2.0L 16V 4WD 10/87 → 02/92 84						BS060 (Graphite)	DS060 ■ (21-28097-20/0)	GS060 (20-28097-00/0)
Celica Coupe 2.0L i Turbo 4WD 02/94 → 11/99								
Celica Coupe 2.0L Turbo 4WD 03/88 → 01/94								
3S-GTE	1998	4	86.00	Injection, DOHC, Turbo	136- 178/ 185- 242			
3S-GTE	1998	4	86.00	Injection, DOHC	136- 178/ 185- 242			
Celica 2.0L GT 09/85 → 08/90 85						BR330 (Graphite) (30-028090-00)	DR330 → Eng. 8xxxxxx	GR330
Celica Coupe 2.0L 08/87 → 08/89								
3S-GELC	1984	4	86.00		103/140			
3S-GEL	1998	4	86.00	DOHC	110/150			
Celica 2.0L XT 02/79 → 07/85 86						AJ960 (Graphite)	CJ962 ■	FJ962
18R	1968	4	88.50	SOHC	63-66/ 86-90			
Celica 2.0L XT 02/82 → 08/85 87						BK700 (Graphite)	DK700 → 08/84	GK700 → 08/84
Celica Coupe 2.0L 01/82 → 10/86								
21R-C/21R-U	1972	4	84.00	SOHC	77/105		GK701 08/85 →	
Celica Convertible 2.0L GTi 05/91 → 01/94 88						BR330 (Graphite) (30-028090-00)	DR330 → 02/92	GR330 → 02/92
Celica Coupe 2.0L GTi 10/89 → 01/94								
3S-GE	1998	4	86.00	Injection, DOHC	115- 129/ 156- 175	→ 02/92 BS060 (Graphite) 02/92 →	→ Eng. 8xxxxxx GR332 → 02/92 Eng. 9xxxxxx →	
Celica Convertible 2.0L i 16V 04/96 → 11/99 89						BS060 (Graphite)	DR332 (21-28090-21/0)	GR332
Celica Coupe 2.0L i 16V 04/96 → 11/99								
3S-GE	1998	4	86.00	Injection, DOHC	115- 129/ 156- 175			
Celica Coupe 2.0L i 16V 11/93 → 11/99 90						BS060 (Graphite) → 02/94	DR332 (21-28090-21/0)	GR332
3S-GE	1998	4	86.00	Injection, DOHC	115- 129/ 156- 175			
Celica 2.2L 06/91 → 12/96 91						BS970 (Graphite) (30-028103-00)	DS970 (21-28103-20/0)	GS970
5S-FE	2164	4	87.00	Injection, DOHC	93-103/ 126- 140			
Celica 2.2L GT 11/93 → 08/99 92						AG9140 (MLS) BS970 (Graphite) (30-028103-00)	CG9140	EG6250
5S-FE	2164	4	87.00	Injection, DOHC	93-103/ 126- 140			

								
		JC545 (x3) ⊕ JE015 [149] ⊕ JE094 ⊕ JE619			KJ722 (x12)	NJ347 38x50x8mm, NBR NJ351 45x62x8mm, NBR NJ044 75x100x13mm, MVQ	NJ963 [70]	 AJ960  BK680  BK700  BR330  BS060  BS970  JC371  JC545  JC840  JC841  JC842  JD112  JD194  JN185  JN629  JN630  JN655  JN768
HBS198 ⊕ [22-71003B] M10x1.25x93mm (x10)	JC840 ■ JC841 ■ JC789 (x2)	JN917 JH5098		PA425 (x16) (50-306560-50)		NJ353 (x2) 35x49x6mm, NBR NJ215 85x105x10mm, FPM		
HBS198 ⊕ [22-71003B] M10x1.25x93mm (x10)	JC840 ■ JC841 ■ ⊕ JE015 (x2) [149] ⊕ JE619	JN629 (50-028187-00) JN630	JH5098	PA425 (x8) (50-306560-50)		NJ353 (x2) 35x49x6mm, NBR NJ344 42x60x7mm, NBR NJ354 85x105x10mm, MVQ	NJ963 [70]	
	JC371 ■ ⊕ JE012 [149] ⊕ JE015 [149] ⊕ JE037			KJ127 (x8)		NJ243 45x68x12mm, NBR NJ030 80x100x12mm, ACM		
	⊕ JE012 (x2) [149] ⊕ JE619 (x2)	JN185		KJ466 (x8)		NJ243 45x68x12mm, NBR NJ030 80x100x12mm, ACM		
HBS198 ⊕ [22-71003B] M10x1.25x93mm (x10)	JC841 ■ →02/92 JD5786 ■ ■ JC842 ■ →02/94 ⊕ JE015 (x2) [149] →02/92 ⊕ JE619 →02/92	JN629 (50-028187-00) →02/92 →Eng.8xxxxxx JN630 →02/92 Eng.9xxxxxx → JN768 02/92 → JN917 02/92 →	JH5098	PA425 (x8) (50-306560-50) PB281 (x8) 02/92 →08/93		NJ353 (x2) 35x49x6mm, NBR NJ344 42x60x7mm, NBR →02/92 NJ354 85x105x10mm, MVQ →02/92	NJ963 [70]	
HBS198 ⊕ [22-71003B] M10x1.25x93mm (x10)	JD5786 ■		JH5098	PA425 (x8) (50-306560-50)		NJ353 (x2) 35x49x6mm, NBR	NJ693 [70]	
HBS198 ⊕ [22-71003B] M10x1.25x93mm (x10)	JD5786 ■ ■ JC842 ■ →02/94	JN768 →02/94 JN917 →02/94	JH5098	PA425 (x8) (50-306560-50)		NJ353 (x2) 35x49x6mm, NBR	NJ693 [70]	
	JD194 ■ JD112 ■ ⊕ JF087 (x2)	JN655 (50-028189-00) (Rubber)		PA425 (x16) (50-306560-50)		NJ347 38x50x8mm, NBR NJ344 42x60x7mm, NBR NJ354 85x105x10mm, MVQ		
		HM5276 ■ (Rubber)						











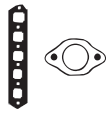

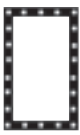

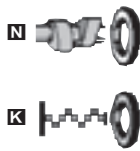

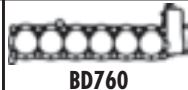

















































































































TOYOTA



KW/PS



Model						Year Range	Power (KW/PS)	Engine Type	Accessories	
Celica 2.4L						01/81 →	93	BJ660 (Graphite) →07/83 BM880 (Graphite) (30-028081-00) 08/83 →	DM881 ■ (21-28081-21/0) 08/83 →	GJ660 →07/83 GM881 08/83 →
22R	2366	4	92.00	SOHC		84/114				
Celica 2.6L Supra						01/80 →	94	BD760 (Graphite)		
4M-EU	2563	6	80.00	SOHC						
Celica Coupe 2.8L I Supra						05/82 →10/86	95	BK460 (Graphite)	DK461	GK461
5M-GE	2759	6	83.00	EFI, DOHC		125/170				
Celica 3.0L 24V						09/87 →	96	BR300 (Graphite) →06/91	DR301 →08/90	GR301 →08/90
7M-GE	2954	6	83.00	DOHC		150/204				
Celica 3.0L Supra 3 Turbo						02/86 →05/93	97	BR300 (Graphite)	DR300	GR300
7M-GTE	2954	6	83.00	DOHC, Turbo		150/204				
Celsior 4.0L						12/88 →08/00	98	AF5031 (MLS) ■ AF5030 (MLS) ■	CF5030	FF5030
1UZ-FE	3969	8	87.50	DOHC, V8		180/245				
Chaser 1.8L						10/82 →10/86	99	BK670 (Graphite)	DK670	GK671
1S	1832	4	80.50			66/89				
Chaser 2.0L						08/88 →07/90	100	AG9990 (MLS)	DT630	GT630
Chaser 2.0L 24V						08/86 →08/91	100	BT630 (Graphite)		
1GFE	1988	6	75.00	Injection, DOHC		114/155				
Chaser 2.0L						01/82 →12/87	101	BL350 (Graphite)	DL350	
2S	1995	4	84.00	SOHC		69-88/ 94-120				
Chaser 2.0L						08/82 →04/91	102	BM480 (Graphite)		
1G-GE	1988	6	75.00	DOHC		110/150				
Chaser 2.0L						01/82 →	103	BK680 (Graphite) (30-028077-00)	DK680	
1G-EU	1988	6	75.00	SOHC		77/105				
Coaster 2.4L						08/82 →12/85	104	BJ660 (Graphite) BM880 (Graphite) (30-028081-00) 01/83 →		GJ661 →12/82 GM880 01/83 →
22R	2366	4	92.00	SOHC		77-81/ 105- 110				
Coaster 2.4L Turbo						01/84 →12/95	105	BM880 (Graphite) (30-028081-00)		
22RTEC	2367	4	92.00	SOHC						
Coaster 3.4L Diesel						08/80 →	106	BJ740 (Graphite) →08/88	DJ740 ○ →08/84 DJ742 08/84 →08/88	GJ740 →08/84 GJ742 08/84 →08/88
3B	3432	4	102.00			66-72/ 90-98				
Coaster 4.0L Diesel						08/87 →12/89	107	BR890 (Fibre)	DR890 ■	GR890
12HT	3980	6	91.00	Turbo		100/136				
Corolla 1.3L						09/79 →08/87	108	BD950 (Graphite) (30-028070-00)	DD955	GD955
4K-C	1290	4	75.00	OHV		42-44/ 57-60				
4K	1290	4	75.00	Carburettor, OHV		42-48/ 57-65				

								
								 BD760  JC584  JC739  JC740  JM025  JN185  JN469  JN631  JN664  JN705  JH024  JJ094
	JC215  JC410  →07/83 JC584  08/83 →  JE012 [149]  JE619 →07/83		JJ322 08/83 →	KJ466 (x8) →07/83 PA136 (x8) 08/83 →	 NJ243  45x68x12mm, NBR  NJ030  80x100x12mm, ACM →07/83  NJ360  80x100x8.5mm, MVQ 08/83 →			
	JB983   JE094		JH024	KH202  (x6) KJ127 (x6)	 NJ243  45x68x12mm, NBR  NJ030  80x100x12mm, ACM	KA555 [13]		
	JC277  JC276   JF087			PA136 (x12)	 NJ102 (x2) 38.5x58x11mm, NBR  NJ344  42x60x7mm, NBR  NJ042  48x70x12mm, NBR  NJ030  80x100x12mm, ACM			
	JC739  JC276   JE015 (x2) [149]	JN631 (x2)		PA425 (x24) (50-306560-50)	 NJ353 (x2) 35x49x6mm, NBR  NJ344  42x60x7mm, NBR  NJ645  52x70x8.5mm, ACM  NJ030  80x100x12mm, ACM			
	JC739  JC740 	JN631 (x2)		PA425 (x24) (50-306560-50)	 NJ353 (x2) 35x49x6mm, NBR  NJ344  42x60x7mm, NBR  NJ645  52x70x8.5mm, ACM  NJ030  80x100x12mm, ACM			
		HM5243 						
	JC402  JE012 [149]  JE106	JN469		KJ466 (x8)	 NJ347 38x50x8mm, NBR  NJ344  42x60x7mm, NBR  NJ354  85x105x10mm, MVQ	NJ963 [70]		
	 JF087 (x2)			PA567 (x24)	 NJ353 (x2) 35x49x6mm, NBR  NJ351  45x62x8mm, NBR  NJ044  75x100x13mm, MVQ			
	JC402  JE012 [149]	JN469		KJ466 (x8)	 NJ347 38x50x8mm, NBR  NJ344  42x60x7mm, NBR			
	 JE019  JE094			PA425 (x12) (50-306560-50)	 NJ353 (x2) 35x49x6mm, NBR  NJ351  45x62x8mm, NBR  NJ407  75x100x8.5mm, MVQ			
	JC545  (x3)  JE015 [149]  JE094  JE619			KJ722 (x12)	 NJ347 38x50x8mm, NBR  NJ351  45x62x8mm, NBR  NJ044  75x100x13mm, MVQ	NJ963 [70]		
	JC577  →12/82 JC215  01/83 → JC410   JE013 [149]  JE619	JN185	JJ322	KJ466 (x8) →07/83 PA136 (x8) 08/83 →	 NJ243  45x68x12mm, NBR  NJ030  80x100x12mm, ACM →07/83  NJ360  80x100x8.5mm, MVQ 08/83 →			
	JC577   JE619	JN185		PA136 (x8)	 NJ243  45x68x12mm, NBR  NJ030  80x100x12mm, ACM			
	JC439  →08/84  JE619 →08/88	JN664 (50-026784-00) →08/88		PA260 (x8) →08/88	 NJ239  50x72x12mm, NBR →08/88  NJ240  95x115x12mm, MVQ →08/88			
		JN705		PA310 (x12)	 NJ239  50x72x12mm, NBR  NJ240  95x115x12mm, MVQ			
	JB910 (x2)  JE619	JM025	JJ094	KJ466 (x8)	 NJ102  38.5x58x11mm, NBR  NJ001  70x92x8.5mm, MVQ			











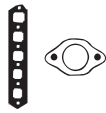

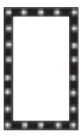

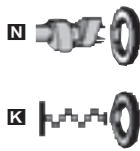

















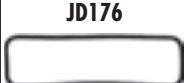





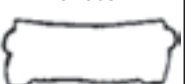





























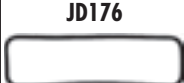











TOYOTA



KW/PS



Corolla 1.3L 10/84 → 08/87 109						BN200 (Graphite) (30-028082-00)		
Corolla 1.3L 12V 07/92 → 05/95								
Corolla 1.3L i 06/89 → 06/92								
2E-LC	1295	4	73.00	SOHC	55/75			
2E	1296	4	73.00	Carburettor, SOHC	53-55/ 72-75			
2E-L	1296	4	73.00		55/75			
2E-E	1296	4	73.00	MPi, SOHC	74/100			
Corolla 1.3L 08/87 → 12/89 110						BN200 (Graphite) (30-028082-00)	DN200 (21-28082-20/0)	
Corolla 1.3L 12V 07/92 → 04/97								
Corolla 1.3L i 08/87 → 12/92								
2E	1296	4	73.00	Carburettor, SOHC	53-55/ 72-75			
2E-E	1296	4	73.00	MPi, SOHC	74/100			
Corolla 1.3L 01/77 → 12/87 111						BD950 (Graphite) (30-028070-00)	DD951 ■ → 12/79 DD952 ■ DD955 1982 →	GD952 GD955 1982 →
Corolla Van 1.3L 01/77 → 12/87								
4K	1290	4	75.00	Carburettor, OHV	42-48/ 57-65			
Corolla 1.3L 01/84 → 12/92 112						BN200 (Graphite) (30-028082-00)	DN200 (21-28082-20/0)	GN200 (20-28082-00/0)
2E	1296	4	73.00	Carburettor, SOHC	53-55/ 72-75			
Corolla 1.3L 05/83 → 12/88 113						BM870 (Graphite)	DM871	
2A-L	1296	4	92.00	SOHC	51/55/ 69/75			
Corolla 1.3L 05/83 → 12/88 114						BM870 (Graphite)	DM871	
2A-L	1296	4	92.00	SOHC	51/55/ 69/75			
Corolla 1.3L XLI 07/92 → 04/97 115						BV330 (Graphite)	DV331	
Corolla 1.3L XLI 16V 07/92 → 09/95								
4E-FE	1331	4	74.00	MPi, SOHC	55-65/ 75-88			
Corolla 1.4L 02/00 → 01/02 116						AB5760 (MLS) (30-029887-00)	CB5760 ■ (21-29887-20/0)	FB5760 (20-29887-00/0)
Corolla 1.4L 16V 02/00 → 01/02								
Corolla 1.4L VVT-i 01/02 →								
Corolla Verso 1.4L VVT-i 01/02 → 05/04								
4ZZ-FE	1398	4	79.00		71/96			
Corolla 1.4L 04/97 → 02/00 117						BV330 (Graphite)	DV331	
4E-FE	1331	4	74.00	MPi, SOHC	55-65/ 75-88			
Corolla 1.4L 04/97 → 02/00 118						BV370 (Graphite)	DV370 (21-28107-20/0)	
4E-FE	1331	4	74.00	MPi, SOHC	55-65/ 75-88			
Corolla 1.4L D Diesel 07/04 → 119						AG7600 (MLS), 0.85mm AG7610 (MLS), 0.90mm AG7620 (MLS), 0.95mm	CG7600 ▲	FG7600 ▲
Corolla 1.4L D4d Diesel 06/04 →								
Corolla Verso 1.4L D4d Diesel 03/04 →								
1ND-TV	1364	4	73.00	Direct Injection, SOHC	55-66/ 75-90			

								
HBS197  [22-71002B] M9x1.25x98mm (x10)	JC558  (x2)  JF087	JN598 (50-026788-00)		PB340  (x4) PA425  (x8) (50-306560-50)	NJ353 35x49x6mm, NBR			 AB5760  BD950  BM870  BN200  BV330  BV370  HA397  JB910  JC116  JC558  JC559  JD085  JD175  JD176  JM025  JN356  JN904  JN865  JN904  JJ094
HBS197  [22-71002B] M9x1.25x98mm (x10)	JC558  (x2)  JF087	JN598 (50-026788-00)		PB340  (x4) PA425  (x8) (50-306560-50)	NJ353 35x49x6mm, NBR			
	JB910 (x2)  JE013 (x2) [149]  JE015 [149]  JE050  JE619 01/79 → 01/82	JM025	JJ094	KJ466 (x8)	NJ102  38.5x58x11mm, NBR NJ001  70x92x8.5mm, MVQ			
	JC559  JC558  (x2) HA397    JE015 [149]	JN598 (50-026788-00)		PA567 (x12)	NJ353 35x49x6mm, NBR NJ353  35x49x6mm, NBR NJ407  75x100x8.5mm, MVQ	NJ654 [70]		
	JC116  JE015 [149]	JN356 → 08/84 JN591 08/84 →		KJ722 (x8)	NJ353 35x49x6mm, NBR NJ349  32.5x46x6mm, NBR NJ001  70x92x8.5mm, MVQ			 JB910  JC116  JC558
	JC116  JE015 [149] 05/82 →	JN356 → 08/84 JN591 08/84 →		KJ722 (x8)	NJ353 35x49x6mm, NBR NJ349  32.5x46x6mm, NBR NJ001  70x92x8.5mm, MVQ			 JC559  JD085  JD175
HBS306  [22-71016B] M9x1.25x98mm (x5) M9x1.25x84mm (x5)	JD085 	JN865 (50-028196-00)			NJ353 35x49x6mm, NBR			 JD176  JM025  JN356  JN904  JN598
HBS385  [22-71021B]	JD5243   (31-029889-00) JD5160  (31-029890-00) (MLS)  KK5495	JM5073 (50-029888-00)		PA5019  (x8) (50-319497-00) PA5020  (x8) (50-319496-00)	NA5089  38x50x8mm, NBR (50-319498-00) NA5090  76x94x8.5mm, FPM (50-319499-00)			
HBS306  [22-71016B] M9x1.25x98mm (x5) M9x1.25x84mm (x5)	JD085 	JN865 (50-028196-00)			NJ353 35x49x6mm, NBR			
HBS306  [22-71016B] M9x1.25x98mm (x5) M9x1.25x84mm (x5)	JD175  JD176 	JN904			NJ353 35x49x6mm, NBR			
					NA5260 38x50x6mm			

TOYOTA



KW/PS

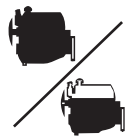

Corolla 1.5L		09/99 → 05/04		120				FB5750 (20-29894-00/0)
Corolla 1.5L G 4WD Altis		11/01 → 05/04						
Corolla Verso 1.5L		03/04 →						
1NZ-FE	1497	4	75.00		78/106			
Corolla 1.5L		01/86 → 12/90		121		BN200 (Graphite) (30-028082-00)		GN201
3E	1456	4	73.00	SOHC				
Corolla 1.5L		03/79 → 09/90		122		BG670 (Fibre) → 1982 BL340 (Graphite) 1983 →	DL340 (21-28079-20/0) → 09/84 DL341 10/84 →	GL340 1983 → 09/84 GL341 10/84 →
3A-U	1453	4	77.50	SOHC				
Corolla 1.5L		05/83 →		123		BL340 (Graphite)		
3A-LU	1452	4	77.50	SOHC				
Corolla 1.5L		08/83 →		124		BR270 (Graphite) (30-028088-00)	DR270 ■ (21-28088-20/0)	GR270
5K	1486	4	80.50		51-52/ 69-71			
5KU	1486	4	80.50	SOHC	51-52/ 69-71			
Corolla 1.5L 16V		01/91 → 07/95		125		BV330 (Graphite)	DV330	GV330
5E-FE	1496	4	74.00	MPi, DOHC	66/89			
Corolla 1.6L		08/85 → 05/88		126		BP530 (Graphite) (30-028085-00)	DP530	GP530
4A-LC	1587	4	81.00	Carburettor, SOHC	53-55/ 72-75			
Corolla 1.6L		02/00 → 01/02		127		AB5760 (MLS) (30-029887-00)	CB5760 ■ (21-29887-20/0)	FB5760 (20-29887-00/0)
Corolla 1.6L 16V		02/00 → 01/02						
Corolla 1.6L VVT-i		01/02 →						
Corolla Verso 1.6L		04/04 →						
Corolla Verso 1.6L VVT-i		01/02 → 05/04						
3ZZ-FE	1598	4	79.00		81/110			
Corolla 1.6L		08/87 → 05/92		128		BR750 (Graphite) (30-028093-00)	DR750 (21-28093-20/0) → 12/88 DR751 01/89 →	GR750 (20-28093-00/0) → 12/88 GR751 01/89 →
Corolla 1.6L 4x4		09/89 → 05/92						
Corolla 1.6L GL 4x4		10/87 → 08/90						
Corolla 1.6L i 4WD		10/87 → 08/90						
Corolla 1.6L XL		09/89 → 04/92						
Corolla 1.6L XLI		11/89 → 06/92						
Corolla 1.6L XLI 4x4		08/88 → 06/92						
4A-F	1587	4	81.00	Carburettor, DOHC	66-70/ 90-95			
4A-FE	1587	4	81.00	Leanburn Injection, DOHC	84/114			
Corolla 1.6L		08/84 → 08/87		129		BL740 (Graphite) BP530 (Graphite) (30-028085-00)	DP531	GP531
4A-C	1587	4	81.00	SOHC	57/77			
Corolla 1.6L		04/97 → 02/00		130		BV370 (Graphite)	DV370 (21-28107-20/0)	
Corolla 1.6L Aut.		04/97 → 02/00						
Corolla 1.6L GLI		07/92 → 04/97						
Corolla 1.6L Si		07/92 → 04/97						
4A-FE	1587	4	81.00	Leanburn Injection, DOHC	84/114			
Corolla 1.6L 16V		01/83 → 12/87		131		BN390 (Graphite) (30-028083-00)	DN392 → 05/84 DN390 06/84 →	GN390 (20-28083-00/0) 06/84 →
4A-GEU	1587	4	81.00	DOHC				

		JD5159 ■ JD5738 ■ (MLS) 0,5mm					 AB5760	 JD175
	JC559 ■ [149]	JN598 <i>(50-026788-00)</i>		PA567 (x12)	35x49x6mm, NBR 35x49x6mm, NBR 80x100x8.5mm, MVQ		 BG670	 JD176
	JC116 [149] (x2) [149] [149]	JN356		KJ722 (x8)	35x49x6mm, NBR 32.5x46x6mm, NBR 70x92x8.5mm, MVQ		 BL340	 JM025
	JC116 (x2) [149]	JN591		KJ722 (x8)	35x49x6mm, NBR 32.5x46x6mm, NBR 70x92x8.5mm, MVQ		 BL740	 JN356
	JB910 (x2) (x2) [149] [149]	JM025	JJ343	KJ466 (x8)	38.5x58x8.5mm, NBR 70x92x8.5mm, MVQ		 BN200	 JN591
	JD085 ■	JN865 <i>(50-028196-00)</i>		PB341 ■ (x8)	35x49x6mm, NBR 35x49x6mm, NBR		 BN390	 JN598
	[149]	JN591		KJ722 (x8)	35x49x6mm, NBR 32.5x46x6mm, NBR 70x92x8.5mm, MVQ		 BP530	 JN603
HBS385 © <i>(22-71021B)</i>	JD5243 ■ <i>(31-029889-00)</i> JD5160 ■ <i>(31-029890-00)</i> (MLS) 	JM5073 <i>(50-029888-00)</i>		PA5019 ■ (x8) <i>(50-319497-00)</i> PA5020 ■ (x8) <i>(50-319496-00)</i>	38x50x8mm, NBR <i>(50-319498-00)</i> 76x94x8.5mm, FPM <i>(50-319499-00)</i>		 BR270	 JN604
HBS203 © <i>(22-71008B)</i> M10x1.25x90mm (x5) M10x1.25x108mm (x5)	JC880 ■ →12/88 JC881 ■ →12/88 (x2) [149]	JN706	JH5099	PA425 (x16) <i>(50-306560-50)</i>	(x2) 35x49x6mm, NBR 32.5x46x6mm, NBR 70x92x8.5mm, MVQ		 BR750	 JN706
	JC116 [149] (x2) [149] 08/83 → 01/86	JN591		KJ722 (x8)	35x49x6mm, NBR 32.5x46x6mm, NBR 70x92x8.5mm, MVQ		 BV330	 JN865
HBS203 © <i>(22-71008B)</i> M10x1.25x90mm (x5) M10x1.25x108mm (x5)	JD175 ■ JD176 ■	JN904		PA425 (x16) <i>(50-306560-50)</i>	(x2) 35x49x6mm, NBR 32.5x46x6mm, NBR 70x92x8.5mm, MVQ		 BV370	 JN904
	JC578 ■ JC579 ■ 	JN603 (x2) JN604		PA425 (x16) <i>(50-306560-50)</i>	(x2) 35x49x6mm, NBR 32.5x46x6mm, NBR 70x92x8.5mm, MVQ		 JB910	 JJ343
							 JC116	
							 JC559	
							 JC578	
							 JC579	
							 JC880	
							 JC881	
							 JD085	











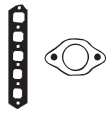

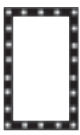

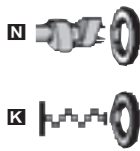







TOYOTA

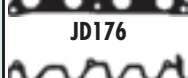

KW/PS

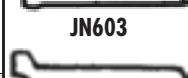

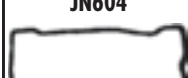
Corolla 1.6L 16V		01/87 → 05/89		132	BR900 (Graphite)	DR900 →05/89	GR900 →05/89
4A-GZE	1587	4	81.00	Injection, DOHC, Turbo	96-127/ 131- 173		
Corolla 1.6L GT 16V		08/85 → 08/87		133	BN390 (Graphite)	DN392 →05/84	GN390 (20-28083-00/0) 06/84 →
Corolla Coupe 1.6L GT 16V		08/83 → 07/87			(30-028083-00)	DN390 06/84 →	
4A-GEL	1587	4	81.00		85-91/ 116- 124		
4A-GE	1587	4	81.00	Injection, DOHC	85-92/ 116- 125		
Corolla 1.6L GTi		08/87 → 04/92		134	BN390 (Graphite)	DN390 →05/89	GN390 (20-28083-00/0) →05/89
4A-GE	1587	4	81.00	Injection, DOHC	85-92/ 116- 125	DR901 05/89 →	GR901 05/89 →
					(30-028083-00) →05/89		
					BR900 (Graphite) 05/89 →		
Corolla 1.6L GTI		07/87 → 06/93		135	BN390 (Graphite)	DN390	
4A-GE	1587	4	81.00	Injection, DOHC	85-92/ 116- 125		
					(30-028083-00) →09/89		
					BR900 (Graphite) 09/89 →		
Corolla 1.6L i		11/89 → 06/93		136	BR750 (Graphite)	DR751	
4A-FE	1587	4	81.00	Leanburn Injection, DOHC	84/114		
					(30-028093-00)		
Corolla Coupe 1.6L 16V		12/85 → 04/87		137	BN390 (Graphite)	DN390	
4A-GEC	1587	4	81.00	DOHC	88/120		
					(30-028083-00)		
Corolla 1.8L VVTL-i TS		02/05 →		138	AG9110 (MLS), 0.4mm	CG9110	EG6290
2ZZ-GE	1796	4	82.00	Injection	141/192		
Corolla 1.8L 16V 4WD		09/95 → 04/97		139	BV360 (MLS)	DV360 (21-28106-20/0)	GV360
Corolla 1.8L AWD		04/97 → 01/02					
Corolla 1.8L GT		11/92 → 05/95					
7A-FE	1762	4	81.00	MPi, DOHC	81/110		
Corolla 1.8L D Diesel		05/83 → 05/88		140	AB5000 (Graphite)	CB5000 07/83 → 12/86	FB5000 07/83 → 12/86
1C	1839	4	83.00	SOHC	54/73	DX010 08/87 →	GX010 08/87 →
					(30-029229-00) 07/83 → 12/86		
					BX010 (MLS) 08/87 →		

								
		JC579 ⊗ JE015 (x2) [149] →05/89 ⊗ JF087 (x2) 06/87→	JN603 (x2)		PA425 (x16) (50-306560-50)	NJ353 (x2) 35x49x6mm, NBR NJ349 32.5x46x6mm, NBR NJ001 70x92x8.5mm, MVQ		 BN390  BR750  BR900  BV360  BX010  JC399  JC576  JC578  JC579  JC879  JD175  JD176  JN532  JN603  JN604  JN706  JN876  JN904
HBS203 (22-71008B) M10x1.25x90mm (x5) M10x1.25x108mm (x5)	JC578 JC579 ⊗ JE015 (x2) [149] ⊗ JE106	JN603 (x2) →05/84 JN604 06/84→	JH5099	PA425 (x16) (50-306560-50)	NJ353 (x2) 35x49x6mm, NBR NJ349 32.5x46x6mm, NBR NJ001 70x92x8.5mm, MVQ			
HBS203 (22-71008B) M10x1.25x90mm (x5) M10x1.25x108mm (x5)	JC578 →05/89 JC879 05/89→ JC579 ⊗ JE015 (x2) [149] →05/89 ⊗ JE106 →05/89 ⊗ JE619 (x2) →05/89 ⊗ JF058 (x2) 05/89→ ⊗ JF087 (x2) 05/89→	JN603 (x2) JN604 →05/89 JN876 05/89→	JH5099	PA425 (x16) (50-306560-50)	NJ353 (x2) 35x49x6mm, NBR NJ349 32.5x46x6mm, NBR NJ001 70x92x8.5mm, MVQ			
HBS203 (22-71008B) M10x1.25x90mm (x5) M10x1.25x108mm (x5)			JH5099					
HBS203 (22-71008B) M10x1.25x90mm (x5) M10x1.25x108mm (x5)		JN706	JH5099					
HBS203 (22-71008B) M10x1.25x90mm (x5) M10x1.25x108mm (x5)			JH5099					
HBS385 (22-71021B)	JD5243 (31-029889-00) JD5160 (31-029890-00) (MLS)	JM5073 (50-029888-00)		PA5019 (50-319497-00) PA5020 (50-319496-00)	NA5089 38x50x8mm, NBR (50-319498-00) NA5090 76x94x8.5mm, FPM (50-319499-00)			
HBS203 (22-71008B) M10x1.25x90mm (x5) M10x1.25x108mm (x5)	JD175 JD176	JN904		PA425 (x16) (50-306560-50)	NJ353 35x49x6mm, NBR NJ001 70x92x8.5mm, MVQ			
HBS042 (22-71001B) M11x1.25x145mm (x10) M11x1.25x123mm (x8)	JC576 JC399 ⊗ JF087	JN532		PA136 (x8)	NJ347 38x50x8mm, NBR →01/85 NJ706 37.5x50x6mm, ACM 02/85→ NJ344 42x60x7mm, NBR NJ346 90x110x8.5mm, MVQ			











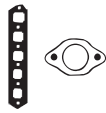

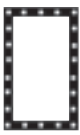
TOYOTA



KW/PS



Corolla 1.8L D Diesel		01/83 → 09/83			141	BL300 (Graphite) (30-026751-10) →07/83 AB5000 (Graphite) (30-029229-00) 07/83→	DL300 →07/83 CB5000 07/83→	FB5000
1C	1839	4	83.00	SOHC	54/73			
Corolla 1.8L D Diesel		06/83 → 08/87			142	AB5000 (Graphite) (30-029229-00)	CB5000	FB5000
1CL	1839	4	83.00	SOHC	47/64			
Corolla 1.8L D Diesel		08/87 → 06/93			143	BX010 (MLS)	DX010	FB5000 GX010
1C	1839	4	83.00	SOHC	54/73			
Corolla 1.8L D Diesel		08/85 → 08/87			144	AB5000 (Graphite) (30-029229-00)	CB5000	FB5000
1CL	1839	4	83.00	SOHC	47/64			
Corolla 1.8L D Diesel		07/85 → 05/88			145	AB5000 (Graphite) (30-029229-00) BR580 (Graphite) (30-028092-00) →04/87	CB5000	FB5000
1CL	1839	4	83.00	SOHC	47/64			
Corolla 1.8L D Diesel		07/87 → 06/93			146	BX010 (MLS)	DX010	FB5000 GX010
1C	1839	4	83.00	SOHC	54/73			
Corolla 1.8L VVT-i TS		01/02 →			147	AG9110 (MLS), 0.4mm	CG9110	EG6290
2ZZ-GE	1796	4	82.00	Injection	141/192			
Corolla Verso 1.8L Corolla Verso 1.8L VVT-i		04/04 → 01/02 → 05/04			148	AB5760 (MLS) (30-029887-00)	CB5760 (21-29887-20/0)	FB5760 (20-29887-00/0)
1ZZ-FE	1794	4	79.00	DOHC	92/95/ 105			

								 AB5760
HBS042 ⊙ (22-71001B) M11x1.25x145mm (x10) M11x1.25x123mm (x8)	JC576 ■ JC399 ■ ⊙JF087	JN532		PA136 (x8)	NJ347 38x50x8mm, NBR NJ344 42x60x7mm, NBR NJ346 90x110x8.5mm, MVQ			 BL300
HBS042 ⊙ (22-71001B) M11x1.25x145mm (x10) M11x1.25x123mm (x8)	JC576 ■ JC399 ■ ⊙JF087	JN532		PA136 (x8)	NJ347 38x50x8mm, NBR →01/85 NJ706 37.5x50x6mm, ACM 02/85→ NJ344 42x60x7mm, NBR NJ346 90x110x8.5mm, MVQ			 BR580
HBS042 ⊙ (22-71001B) M11x1.25x145mm (x10) M11x1.25x123mm (x8)	⊙JF087	JN532		PA136 (x8)	NJ706 37.5x50x6mm, ACM NJ344 42x60x7mm, NBR NJ346 90x110x8.5mm, MVQ			 BX010
HBS042 ⊙ (22-71001B) M11x1.25x145mm (x10) M11x1.25x123mm (x8)	JC576 ■ JC399 ■	JN532		PA136 (x8)	NJ347 38x50x8mm, NBR →01/85 NJ706 37.5x50x6mm, ACM 02/85→ NJ344 42x60x7mm, NBR NJ346 90x110x8.5mm, MVQ			 JC399
HBS042 ⊙ (22-71001B) M11x1.25x145mm (x10) M11x1.25x123mm (x8)	JC576 ■ JC399 ■ ⊙JF087	JN532		PA136 (x8)	NJ706 37.5x50x6mm, ACM NJ344 42x60x7mm, NBR NJ346 90x110x8.5mm, MVQ			 JC576
HBS042 ⊙ (22-71001B) M11x1.25x145mm (x10) M11x1.25x123mm (x8)	JC576 ■ JC399 ■ ⊙JF087	JN532		PA136 (x8)	NJ706 37.5x50x6mm, ACM NJ344 42x60x7mm, NBR NJ346 90x110x8.5mm, MVQ			 JN532
HBS385 ⊙ (22-71021B)	JD5243 ■ (31-029889-00) JD5160 ■ (31-029890-00) (MLS) ⊙KK5495	JM5073 (50-029888-00)		PA5019 (50-319497-00) PA5020 (50-319496-00)	NA5089 38x50x8mm, NBR (50-319498-00) NA5090 76x94x8.5mm, FPM (50-319499-00)			
HBS385 ⊙ (22-71021B)	JD5243 ■ (31-029889-00) JD5160 ■ (31-029890-00) (MLS) ⊙KK5495	JM5073 (50-029888-00)		PA5019 (x8) (50-319497-00) PA5020 (x8) (50-319496-00)	NA5089 38x50x8mm, NBR (50-319498-00) NA5090 76x94x8.5mm, FPM (50-319499-00)			



KW/PS



Corolla 1.9L D Diesel				02/00 → 01/02	149	AA5830 (Steel Elastomer), 1.26mm, 1 Hole (30-029190-00) -0.51 → 0.54mm AA5840 (Steel Elastomer), 1.30mm, 2 Holes (30-029191-00) -0.55 → 0.58mm AA5850 (Steel Elastomer), 1.34mm, 3 Holes (30-029192-00) -0.59 → 0.62mm AA5860 (Steel Elastomer), 1.38mm, 4 Holes (30-029193-00) -0.63 → 0.66mm AA5870 (Steel Elastomer), 1.42mm, 5 Holes (30-029194-00) -0.67 → 0.70mm AA5880 (Steel Elastomer), 1.46mm, 6 Holes (30-029195-00) -0.71 → 0.75mm	CA5830▲ (21-29482-20/0)	EA5830
1WZ	1867	4	82.20	SOHC	51/69			
Corolla 2.0L D4d Diesel				06/04 →	150	AD5370 (MLS), 1mm, 1 Notch AG7480 (MLS), 1.05mm, 2 Notches 1CD-FTV AG7490 (MLS), 1.1mm, 3 Notches 1CD-FTV AG7500 (MLS), 1.15mm, 4 Notches 1CD-FTV AG7510 (MLS), 1.2mm, 5 Notches 1CD-FTV	CG7491▲	FG7480▲
Corolla 2.0L D-4D Diesel				08/00 → 01/02				
Corolla 2.0L D4d GS Diesel				08/00 → 10/01				
Corolla Verso 2.0L D4d Diesel				06/04 →				
1CD-FTV	1995	4	82.20	Direct Injection, DOHC	66-85/ 90-116			
Corolla 2.0L D Diesel				12/87 → 04/97	151	AG7650 (MLS), 1.35mm, 2 Holes 11/95 → 2C AG7660 (MLS), 1.45mm, 3 Holes 11/95 → 2C AD5350 (MLS), 1.25mm, 1 Hole 01/96 →	DR581 (21-28092-21/0) → 12/95 CD5350▲ 01/96 →	FG7650▲ GR581 → 12/95
2C	1974	4	86.00		51-54/ 69-73			
Corolla 2.0L D Diesel				07/92 → 04/97	152	AG7650 (MLS), 1.35mm, 2 Holes 11/95 → 2C AG7660 (MLS), 1.45mm, 3 Holes 11/95 → 2C AD5350 (MLS), 1.25mm, 1 Hole 01/96 →	DR581 (21-28092-21/0) → 12/95 CD5350▲ 01/96 →	FG7650▲ GR581 → 12/95
2C	1974	4	86.00		51-54/ 69-73			
Corolla 2.0L D Diesel				04/97 → 02/00	153	AD5350 (MLS), 1.25mm, 1 Hole AG7650 (MLS), 1.35mm, 2 Holes 08/97 → 10/99 2C-E AG7660 (MLS), 1.45mm, 3 Holes 08/97 → 10/99 2C-E	CD5350▲	FG7650▲
2C-E	1975	4	86.00	SOHC	53/72			
Corolla 2.0L D Diesel				04/97 → 02/00	154	AD5350 (MLS), 1.25mm, 1 Hole AG7650 (MLS), 1.35mm, 2 Holes 08/97 → 10/99 AG7660 (MLS), 1.45mm, 3 Holes 08/97 → 10/99	CD5350▲	FG7650▲
2C-E	1975	4	86.00	SOHC	53/72			

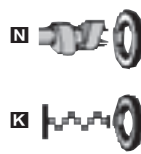
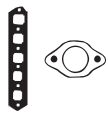

AA5830, AA5840,
AA5850, AA5860,
AA5870, AA5880



JC399



JC444



JC576

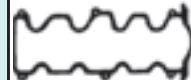

JN532



KW/PS



Model		Year Range		Power (KW/PS)	Engine Details	Part Numbers	Accessories
Corolla 2.0L D-4D Diesel		09/00 → 01/02		155	AD5370 (MLS), 1mm, 1 Notch	CG7480▲	FG7480▲
Corolla Verso 2.0L D-4D Diesel		01/02 → 05/04			AG7480 (MLS), 1.05mm, 2 Notches	CG7490▲	
1CD-FTV	1995	4	82.20	66-85/ 90-116	Direct Injection, DOHC	CG7491▲	
Corolla 2.0L TD Diesel		07/94 → 09/97		156			FG7650▲
2C-T	1975	4	86.00	62/84	SOHC		
Corolla 2.2L TD Diesel		04/98 → 10/01		157	AG5240 (Steel Elastomer), 1.45mm, 3 Holes	CD5340	
3C-TE	2184	4	86.00	66/89	SOHC		
Corona 1.6L 16V		01/83 → 12/87		158	BN390 (Graphite)	DN392	GN390
4A-GEU	1587	4	81.00		DOHC	→05/84	(20-28083-00/0)
Corona 1.8L		10/82 → 10/86		159	BK670 (Graphite)	DK670	GK671
1S	1832	4	80.50	66/89			
Corona 1.8L 16V		11/89 →		160	BW460 (Graphite)		
4S-FE	1838	4	82.50		DOHC		
Corona 1.8L D Diesel		04/82 → 09/83		161	BL300 (Graphite)	DL300	FB5000
1C	1839	4	83.00	54/73	SOHC	→07/83	07/83 →
Corona 2.0L D Diesel		01/84 → 01/92		162			FG7650▲
2C	1974	4	86.00	51-54/ 69-73			
Corona 2.0L		10/93 → 09/95		163			FD5330
3S-FE	1998	4	86.00	98/133	Injection, DOHC		
	1998	4	86.00	88-98/ 120- 133			
Corona 2.0L Diesel		01/83 → 12/87		164	BR580 (Graphite)	DR581	GR581
2C	1974	4	86.00	51-54/ 69-73		→07/83	(21-28092-21/0)
Corona 2.0L		01/82 → 12/87		165	BL350 (Graphite)	DL350	
2S	1995	4	84.00	69-88/ 94-120	SOHC		
Corona 2.0L		08/88 → 07/90		166	BT630 (Graphite)	DT630	GT630
1G-FE	1988	6	75.00	114/155	Injection, DOHC		
Corona 2.0L MkII		01/82 →		167	BK680 (Graphite)	DK680	
1G-EU	1988	6	75.00	77/105	SOHC		
Corona 2.0L		08/82 → 04/91		168	BM480 (Graphite)		
1G-GE	1988	6	75.00	110/150	DOHC		

HBS314 ⊕ (22-71019B) M11x1.25x160mm (x8) M12x1.25x104mm (x10)	JD5901 ■	JM5148						
	JC578 ■ JC579 ■ ⊕JE106	JN603 (x2) JN604		PA425 (x16) (50.306560-50)	NJ353 35x49x6mm, NBR NJ349 ■ 32.5x46x6mm, NBR NJ001 ■ 70x92x8.5mm, MVQ			
	JC402 ⊕JE012 [149] ⊕JE106	JN469		KJ466 (x8)	NJ347 38x50x8mm, NBR NJ344 ■ 42x60x7mm, NBR NJ354 ■ 85x105x10mm, MVQ	NJ963 [70]		
	JD112 ■ ⊕JF058	JN655 (50-028189-00) (Rubber)		PA425 (x16) (50.306560-50)	NJ347 38x50x8mm, NBR NJ344 ■ 42x60x7mm, NBR NJ354 ■ 85x105x10mm, MVQ	NJ963 [70]		
	⊕JF087	JN532		PA136 (x8)	NJ347 38x50x8mm, NBR NJ344 ■ 42x60x7mm, NBR NJ346 ■ 90x110x8.5mm, MVQ			
HBS042 ⊕ (22-71001B) M11x1.25x145mm (x10) M11x1.25x123mm (x8)	JC576 ■ JC399 ■ ⊕JE015 [149] ⊕JE106	JN532		PA136 (x8)	NJ706 37.5x50x6mm, ACM NJ344 ■ 42x60x7mm, NBR NJ346 ■ 90x110x8.5mm, MVQ	NJ654 [70]		
	JC402 ⊕JE012 [149]	JN469		KJ466 (x8)	NJ347 38x50x8mm, NBR NJ344 ■ 42x60x7mm, NBR			
	⊕JF087 (x2)			PA567 (x24)	NJ353 (x2) 35x49x6mm, NBR NJ351 ■ 45x62x8mm, NBR NJ044 ■ 75x100x13mm, MVQ			
	JC545 ■ (x3) ⊕JE015 [149] ⊕JE094 ⊕JE619			KJ722 (x12)	NJ347 38x50x8mm, NBR NJ351 ■ 45x62x8mm, NBR NJ044 ■ 75x100x13mm, MVQ	NJ963 [70]		
	⊕JE019 ⊕JE094			PA425 (x12) (50.306560-50)	NJ353 (x2) 35x49x6mm, NBR NJ351 ■ 45x62x8mm, NBR NJ407 ■ 75x100x8.5mm, MVQ			



KW/PS



Model	Year Range	Power (KW/PS)	Cylinders	Displacement (cc)	Configuration	Part Number	Material	Part Number	Material
Corona 2.4L 22R	01/81 →	169 84/114	4	92.00	SOHC	BJ660 (Graphite) →07/83 BM880 (Graphite) (30-028081-00) 08/83 →	DM881 ■ (21-28081-21/0) 08/83 →	GJ660 →07/83 GM881 08/83 →	
Corsa 1.3L 2A-L	05/83 →12/88	170 51/55/ 69/75	4	92.00	SOHC	BM870 (Graphite)	DM871		
Corsa 1.5L 3A-U	03/79 →09/90	171	4	77.50	SOHC	BG670 (Fibre) →1982 BL340 (Graphite) 1983 →	DL340 (21-28079-20/0) →09/84 DL341 10/84 →	GL340 1983 →09/84 GL341 10/84 →	
Cressida 1.8L 1S	10/82 →10/86	172 66/89	4	80.50		BK670 (Graphite)	DK670	GK671	
Cressida 2.0L 1G-FE	08/88 →09/92	173 114/155	6	75.00	Injection, DOHC	AG9990 (MLS) BT630 (Graphite)	DT630	GT630	
Cressida 2.0L 18R	01/72 →07/77	174 63-66/ 86-90	4	88.50	SOHC	AJ960 (Graphite)	CJ960 →12/76 CJ962 ■ 01/77 →	FJ960 →12/76 FJ962 01/77 →	
Cressida 2.0L 1G-GE	08/82 →04/91	175 110/150	6	75.00	DOHC	BM480 (Graphite)			
Cressida 2.0L 1G-E	01/82 →	176 80/109	6	75.00	SOHC	BK680 (Graphite) (30-028077-00)	DK680		
Cressida 2.0L 2S	01/82 →12/87	177 69-88/ 94-120	4	84.00	SOHC	BL350 (Graphite)	DL350		
Cressida 2.4L TD Diesel 2L-T	05/85 →09/88	178 63-66/ 85-90	4	92.00	SOHC	BL950 (Graphite) (30-026758-10) BT130 (Fibre) (30-028104-00)			
Cressida 2.4L TD Diesel 2L-TE	01/88 →	179	4	92.00	SOHC, Turbo	BT130 (Fibre) (30-028104-00) 08/87 →07/88 BW800 (MLS) 08/88 →	DT130 08/87 →07/88	GT130 08/87 →07/88 GW800 08/88 →	
Cressida 2.6L 4M-EU	01/80 →	180	6	80.00	SOHC	BD760 (Graphite)			
Cressida 2.8L 5M-GE	12/81 →12/85	181 125/170	6	83.00	EFI, DOHC	BK460 (Graphite)	DK461	GK461	
Cresta 1.8L 1S	10/82 →10/86	182 66/89	4	80.50		BK670 (Graphite)	DK670	GK671	
Cresta 2.0L Cresta 2.0L 24V Cresta 2.0L VVTi 24V 1G-FE	08/88 →07/90 08/84 →08/88 10/96 →09/01	183 114/155	6	75.00	Injection, DOHC	AG9990 (MLS) BT630 (Graphite)	DT630	GT630	

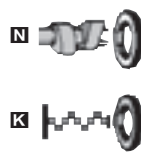
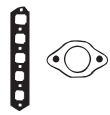

	JC215 JC410 →07/83 JC584 08/83 → JE012 [149] JE619 →07/83		JJ322 08/83 →	KJ466 (x8) →07/83 PA136 (x8) 08/83 →	NJ243 45x68x12mm, NBR NJ030 80x100x12mm, ACM →07/83 NJ360 80x100x8.5mm, MVQ 08/83 →	
	JC116 JE015 [149] 05/82 →	JN356 →08/84 JN591 08/84 →		KJ722 (x8)	NJ353 35x49x6mm, NBR NJ349 32.5x46x6mm, NBR NJ001 70x92x8.5mm, MVQ	
	JC116 JE012 [149] JE013 (x2) [149] →12/82 JE015 [149]	JN356		KJ722 (x8)	NJ353 35x49x6mm, NBR NJ349 32.5x46x6mm, NBR NJ001 70x92x8.5mm, MVQ	
	JC402 JE012 [149] JE106 JF087 (x2)	JN469		KJ466 (x8) PA567 (x24)	NJ347 38x50x8mm, NBR NJ344 42x60x7mm, NBR NJ354 85x105x10mm, MVQ NJ353 (x2) 35x49x6mm, NBR NJ351 45x62x8mm, NBR NJ044 75x100x13mm, MVQ	NJ963 [70]
	JC371 JE012 [149] JE015 [149] JE037 JE019 JE094	JM029		KJ127 (x8) PA425 (x12) (50.306560-50)	NJ243 45x68x12mm, NBR NJ030 80x100x12mm, ACM NJ353 (x2) 35x49x6mm, NBR NJ351 45x62x8mm, NBR NJ407 75x100x8.5mm, MVQ	
	JC545 (x3) JE015 [149] JE094 JE619			KJ722 (x12)	NJ347 38x50x8mm, NBR NJ351 45x62x8mm, NBR NJ044 75x100x13mm, MVQ	NJ963 [70]
	JC402 JE012 [149]	JN469		KJ466 (x8)	NJ347 38x50x8mm, NBR NJ344 42x60x7mm, NBR	
HBS315 [22-71020B] M12x1.25x126mm (x14) M12x1.25x106mm (x4)	JC640 →07/88 JC445 →07/88	JN567 HL510 →07/88	JJ150 →07/88	PA136 (x8) →07/88 PA138 (x8) 08/88 →	NJ344 42x60x7mm, NBR →07/88 NJ349 32.5x46x6mm, NBR 08/88 → NJ344 42x60x7mm, NBR NJ354 85x105x10mm, MVQ	
	JB983 JE094		JH024	KH202 (x6) KJ127 (x6)	NJ243 45x68x12mm, NBR NJ030 80x100x12mm, ACM NJ102 (x2) 38.5x58x11mm, NBR NJ344 42x60x7mm, NBR NJ042 48x70x12mm, NBR NJ030 80x100x12mm, ACM	KA555 [13]
	JC277 JC276 JF087			PA136 (x12)	NJ102 (x2) 38.5x58x11mm, NBR NJ344 42x60x7mm, NBR NJ042 48x70x12mm, NBR NJ030 80x100x12mm, ACM	
	JC402 JE012 [149] JE106 JF087 (x2)	JN469		KJ466 (x8) PA567 (x24)	NJ347 38x50x8mm, NBR NJ344 42x60x7mm, NBR NJ353 (x2) 35x49x6mm, NBR NJ351 45x62x8mm, NBR NJ044 75x100x13mm, MVQ	NJ963 [70]

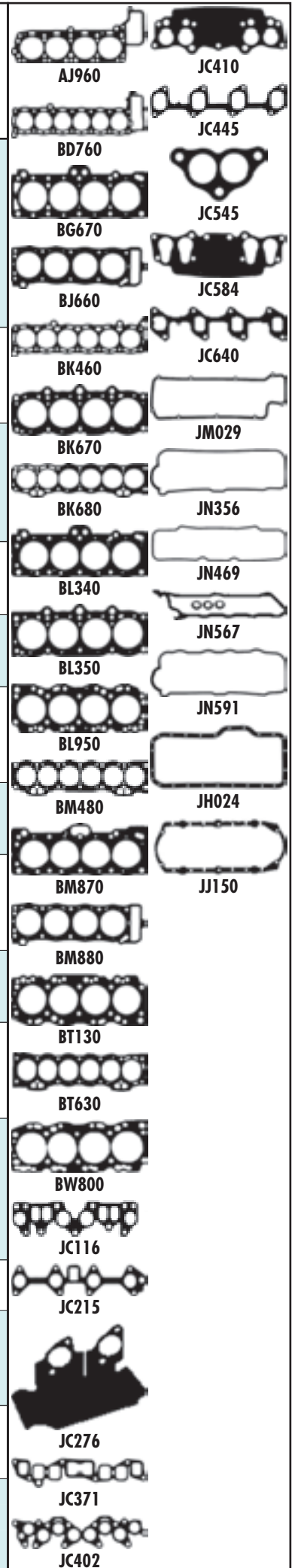

TOYOTA



KW/PS



Cresta 2.0L 01/82 → 184						BK680 (Graphite) (30-028077-00)	DK680	
1G-E	1988	6	75.00	SOHC	80/109			
Cresta 2.0L 08/82 → 04/91 185						BM480 (Graphite)		
1G-GE	1988	6	75.00	DOHC	110/150			
Cresta 2.0L 01/82 → 12/87 186						BL350 (Graphite)	DL350	
2S	1995	4	84.00	SOHC	69-88/ 94-120			
Crown 2.0L 08/88 → 07/90 187						BT630 (Graphite)	DT630	GT630
1G-FE	1988	6	75.00	Injection, DOHC	114/155			
Crown 2.0L 01/83 → 08/87 188						BL820 (Graphite) → 08/85 BL822 (Graphite), 1.80mm → 08/85 BN640 (Graphite) 08/85 →	DL820 ■ → 08/85 DN640 08/85 →	GL820 → 08/85 GN640 08/85 →
3Y	1998	4	86.00	Carburettor, OHV	65/88			
Crown 2.0L 08/82 → 04/91 189						BM480 (Graphite)		
1G-GE	1988	6	75.00	DOHC	110/150			
Crown 2.4L Diesel 08/88 → 190						BW800 (MLS)	DW801 (21-28840-21/0)	GW801 (20-28840-00/0)
2L	2446	4	92.00	SOHC	53-61/ 72-83			
Crown 2.4L Diesel 08/83 → 191						BL950 (Graphite) (30-026758-10) → 07/87 BT130 (Fibre) (30-028104-00) 08/87 → 07/88 BW800 (MLS) 08/88 →	DL951 (21-26758-23/0) → 07/87 DT130 08/87 → 07/88	GL951 (20-26758-01/0) → 07/87 GT130 08/87 → 07/88 GW800 08/88 →
2L-TE	2446	4	92.00	SOHC, Turbo				
Crown 2.8L 12/81 → 12/85 192						BK460 (Graphite)	DK461	GK461
5M-GE	2759	6	83.00	EFI, DOHC	125/170			
Crown 3.0L 09/87 → 193						BR300 (Graphite) → 06/91	DR301 → 08/90	GR301 → 08/90
7M-GE	2954	6	83.00	DOHC	150/204			
Crown 3.0L 02/86 → 05/93 194						BR300 (Graphite)	DR300	GR300
7M-GTE	2954	6	83.00	DOHC, Turbo	150/204			
Crown 4.0L 08/91 → 08/99 195							CF5030	FF5030
Crown 4.0L 4x4 10/92 → 08/99								
1UZ-FE	3969	8	87.50	DOHC, V8	180/245			
Deliboy 2.0L D Diesel 10/89 → 06/99 196								FG7650 ▲
2C	1974	4	86.00		51-54/ 69-73			
Dyna 2.0L 09/84 → 08/87 197						BL820 (Graphite) → 08/85 BL822 (Graphite), 1.80mm → 08/85		
3Y	1998	4	86.00	Carburettor, OHV	65/88			
Dyna 2.2L 01/88 → 198						BP650 (Graphite) (30-028086-00)	DP650 ■	GP650
4Y	2237	4	91.00	OHV	69/93			

		JC545 (x3) JE015 [149] JE094 JE619			KJ722 (x12)	NJ347 38x50x8mm, NBR NJ351 45x62x8mm, NBR NJ044 75x100x13mm, MVQ	NJ963 [70]	BK460 BK680 BL350 BL820 BL822 BL950 BM480 BN640 BP650 BR300 BT130 BT630 BW800 JC276 JC402 JC445 JC545 JC640 JC658 JC739	JC740 JN469 JN551 JN567 JN631 JN965 JJ150
		JE019 JE094		PA425 (x12) <i>(50.306560-50)</i>	NJ353 (x2) 35x49x6mm, NBR NJ351 45x62x8mm, NBR NJ407 75x100x8.5mm, MVQ				
		JC402 JE012 [149]	JN469		KJ466 (x8)	NJ347 38x50x8mm, NBR NJ344 42x60x7mm, NBR			
		JF087 (x2)			PA567 (x24)	NJ353 (x2) 35x49x6mm, NBR NJ351 45x62x8mm, NBR NJ044 75x100x13mm, MVQ			
		JC658 08/85 → JC615 08/85 → JE012 (x2) [149] JE124 (x2) [149]	JN551		PA385 (x8)	NJ344 42x60x7mm, NBR NJ360 80x100x8.5mm, MVQ			
		JE019 JE094			PA425 (x12) <i>(50.306560-50)</i>	NJ353 (x2) 35x49x6mm, NBR NJ351 45x62x8mm, NBR NJ407 75x100x8.5mm, MVQ			
		HBS315 <i>(22-71020B)</i> M12x1.25x126mm (x14) M12x1.25x106mm (x4)	JE015 [149] JE017	JN965 08/88 →		NJ349 32.5x46x6mm, NBR NJ354 85x105x10mm, MVQ			
		HBS315 <i>(22-71020B)</i> M12x1.25x126mm (x14) M12x1.25x106mm (x4)	JC640 →07/88 JC445 →07/88 JE619 →07/87	JN567 HL510 →07/88	JJ150 →07/88	PA136 (x8) →07/88 PA138 (x8) 08/88 →	NJ344 42x60x7mm, NBR NJ349 32.5x46x6mm, NBR NJ344 42x60x7mm, NBR NJ354 85x105x10mm, MVQ		
		JC277 JC276 JF087			PA136 (x12)	NJ102 (x2) 38.5x58x11mm, NBR NJ344 42x60x7mm, NBR NJ042 48x70x12mm, NBR NJ030 80x100x12mm, ACM			
		JC739 JC276 JE015 (x2) [149]	JN631 (x2)		PA425 (x24) <i>(50.306560-50)</i>	NJ353 (x2) 35x49x6mm, NBR NJ344 42x60x7mm, NBR NJ645 52x70x8.5mm, ACM NJ030 80x100x12mm, ACM			
		JC739 JC740	JN631 (x2)		PA425 (x24) <i>(50.306560-50)</i>	NJ353 (x2) 35x49x6mm, NBR NJ344 42x60x7mm, NBR NJ645 52x70x8.5mm, ACM NJ030 80x100x12mm, ACM			
			HM5243						
		JC615 JE012 (x2) [149]	JN551		PA385 (x8)	NJ344 42x60x7mm, NBR NJ360 80x100x8.5mm, MVQ			







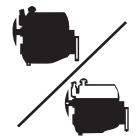



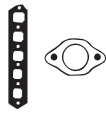

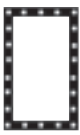

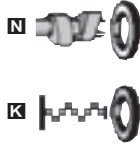

























































TOYOTA



KW/PS



Dyna 2.4L Diesel 08/88 → 199						BW800 (MLS)	DW801 (21-28840-21/0)	GW801 (20-28840-00/0)
2L	2446	4	92.00	SOHC	53-61/ 72-83			
Dyna 2.4L D Diesel 08/77 → 08/87 200						BE390 (Graphite) →08/80 BK910 (Fibre) 09/80 →	DE392■ →08/80	GE392 →08/80
2J	2449	4	88.00	Indirect Injection	55/75			
Dyna 2.5L Diesel 01/70 → 12/83 201						BE390 (Graphite) →08/80 BK910 (Fibre) 09/80 →	DE392■ →08/80	GE392 →08/80
2J	2449	4	88.00	Indirect Injection	55/75			
Dyna D4d Diesel 08/01 → 202							CF5980▲	FF5980▲
2KD-FTV	2494	4	92.00	Direct Injection, DOHC	65-75/ 88-102			
Dyna 3.0L Diesel 01/85 → 203						BR950 (Graphite)	DR951	GR951
11B	2977	4	95.00	Injection	59/80			
Dyna 3.4L Diesel 09/84 → 08/88 204						BJ740 (Graphite)	DJ741	GJ741
13B	3432	4	102.00	Direct Injection	66/89			
Dyna 3.4L D Diesel 08/77 → 08/87 205						BJ740 (Graphite) 09/84 →	DJ741 09/84 →	GJ741 09/84 →
13B	3432	4	102.00	Direct Injection	66/89			
Dyna 3.4L TD Diesel 10/85 → 01/90 206						BJ740 (Graphite)		
13BT	3431	4	102.00	Direct injection, Turbo	91/124			
Echo 1.0L VVTi 04/03 → 08/05 207							CD5380	FD5380
1SZ-FE	998	4	69.00		50/68			
Echo 1.4L D4d Diesel 01/00 → 03/03 208						AG7600 (MLS), 0.85mm AG7610 (MLS), 0.90mm AG7620 (MLS), 0.95mm	CG7600▲	FG7600▲
1ND-TV	1364	4	73.00	Direct Injection, SOHC	55-66/ 75-90			
Echo 1.5L VVTi 04/99 → 08/05 209								FB5750 (20-29894-00/0)
1NZ-FE	1497	4	75.00		78/106			
Funcargo 1.5L VVTi 03/00 → 210								FB5750 (20-29894-00/0)
1NZ-FE	1497	4	75.00		78/106			
Gaia 2.0L VVTi 05/98 → 10/03 211							CF5781	FF5781
Gaia 2.0L VVTi 4x4 05/98 → 10/03								
1AZ-FSE	1998	4	86.00	Injection, DOHC	108- 110/ 147- 150			
Granvia 3.4L 07/91 → 08/98 212								
5VZ-FE	3378	6	93.50		131/178			
Hiace 1.3L 16V 05/92 → 04/97 213						BV330 (Graphite)	DV331	
4E-FE	1331	4	74.00	MPi, SOHC	55-65/ 75-88			
Hiace Van 1.5L 01/86 → 12/90 214						BN200 (Graphite) (30-028082-00)		GN201
3E	1456	4	73.00	SOHC				
Hiace 1.8L 03/83 → 11/89 215						BL820 (Graphite) BL822 (Graphite), 1.80mm	DL820■	GL820
Hiace Van 1.8L 03/83 → 11/89								
2Y	1812	4	86.00	OHV	57/77			
Hiace 2.0L 08/89 → 08/95 216						BW560 (Graphite)	DW560	GW560
Hiace Van 2.0L 02/90 → 08/95								
1RZ	1998	4	86.00		74/100			
Hiace 2.0L 01/83 → 11/89 217						BL820 (Graphite) →08/85 BL822 (Graphite), 1.80mm →08/85 BN640 (Graphite) 08/85 →	DL820■ →08/85 DN640 08/85 →	GL820 →08/85 GN640 08/85 →
3Y	1998	4	86.00	Carburettor, OHV	65/88			

									
HBS315  (22-71020B) M12x1.25x126mm (x14) M12x1.25x106mm (x4)	 JE017	JN965				 NJ349 32.5x46x6mm, NBR  NJ344 42x60x7mm, NBR  NJ354 85x105x10mm, MVQ		 BE390  BJ740  BK910  BL820  BL822  BN200  BN640  BR950  BV330  BW560  BW800  JC559  JC658  JD085  JM068  JN551  JN598  JN865  JN965	
	 JE015 [149]		JJ250 →08/80	PA192 (x8) →08/80 PA209 (x4) 09/80→		 NJ239 50x72x12mm, NBR			
	 JE015 [149]		JJ250 →08/80	PA192 (x8) →08/80 PA209 (x4) 09/80→		 NJ239 50x72x12mm, NBR			
	 JE048 (x2)  JE619	JM068		PA260 (x8)		 NJ239 50x72x12mm, NBR  NJ240 95x115x12mm, MVQ			
	 JE619	JM068		PA260 (x8)		 NJ239 50x72x12mm, NBR  NJ240 95x115x12mm, MVQ			
	 JE619	JM068		PA260 (x8)		 NJ239 50x72x12mm, NBR  NJ240 95x115x12mm, MVQ			
				PA260 (x8)		 NJ239 50x72x12mm, NBR  NJ240 95x115x12mm, MVQ			
						 NA5260 38x50x6mm			
	JA5058 								
HBS306  (22-71016B) M9x1.25x98mm (x5) M9x1.25x84mm (x5)	 JD085 	JN865 (50-028196-00)				 NJ353 35x49x6mm, NBR			
	 JC559   JE015 [149]	JN598 (50-026788-00)		PA567 (x12)		 NJ353 35x49x6mm, NBR  NJ353 35x49x6mm, NBR  NJ360 80x100x8.5mm, MVQ			
	 JE012 (x2) [149]  JE124 (x2) [149]	JN551				 NJ344 42x60x7mm, NBR  NJ360 80x100x8.5mm, MVQ			
HBS425 (22-71030B) M11x1.25x105mm (x10)	 JE012 [149]			PA136 (x8)					
	 JC658  08/85→  JC615  08/85→  JE012 (x2) [149]  JE124 (x2) [149]	JN551		PA385 (x8)		 NJ344 42x60x7mm, NBR  NJ360 80x100x8.5mm, MVQ			

TOYOTA



KW/PS



Hiace 2.0L 4x4 Mk II		08/87 → 07/89		218		BL820 (Graphite) → 08/85	DL820 ■ → 08/85	GL820 → 08/85
Hiace Van 2.0L		01/84 → 11/89				BL822 (Graphite), 1.80mm → 08/85	DN640 08/85 →	GN640 08/85 →
3Y	1998	4	86.00	Carburettor, OHV	65/88	BN640 (Graphite) 08/85 →		
Hiace 2.2L		01/88 →		219		BP650 (Graphite) (30-028086-00)	DP650 ■	GP650
4Y	2237	4	91.00	OHV	69/93			
Hiace 2.4L		08/89 → 04/98		220		BX060 (Graphite)	DX060 ■	GX060 ■
Hiace 2.4L 4WD		08/89 → 04/98						
Hiace Van 2.4L		08/89 → 04/98						
Hiace Van 2.4L 4WD		08/89 → 04/98						
2RZ-E	2438	4	95.00	SOHC	85/115			
2RZ	2438	4	95.00	SOHC				
Hiace 2.4L D Diesel		10/93 → 08/95		221		BL950 (Graphite) (30-026758-10)	DW801 (21-28840-21/0)	
2L	2446	4	92.00	SOHC	53-61/ 72-83	BW800 (MLS)		
Hiace 2.4L D Diesel		08/84 → 08/89		222		BL950 (Graphite) (30-026758-10)	DL950 → 08/88	GL950 → 08/88
Hiace Van 2.4L D Diesel		05/84 → 11/89				→ 08/88	DW801 (21-28840-21/0)	GW801 (20-28840-00/0)
2L	2446	4	92.00	SOHC	53-61/ 72-83	BW800 (MLS) 08/88 →	08/88 →	08/88 →
Hiace 2.4L D Diesel		08/89 → 08/95		223		BW800 (MLS)	DW801 (21-28840-21/0)	GW801 (20-28840-00/0)
Hiace Van 2.4L D Diesel		02/90 → 08/95						
2L	2446	4	92.00	SOHC	53-61/ 72-83			
Hiace 2.4L D 4WD Diesel		08/89 → 08/95		224		BL950 (Graphite) (30-026758-10)	DX060 ■	GX060 ■
Hiace Van 2.4L D 4WD Diesel		08/89 → 08/95				BX060 (Graphite)		
2L	2446	4	92.00	SOHC	53-61/ 72-83			
Hiace 2.4L TD Diesel		08/95 →		225		BL950 (Graphite) (30-026758-10)	DW801 (21-28840-21/0)	GW800
Hiace 2.4L TD 4WD Diesel		08/95 →				BT130 (Fibre)		
Hiace Van 2.4L TD Diesel		08/95 →				(30-028104-00)		
Hiace Van 2.4L TD 4WD Diesel		08/95 →				BW800 (MLS)		
2L-T	2446	4	92.00	SOHC	63-66/ 85-90			
Hiace 2.5L D-4D 4WD Mk IV Diesel		11/01 →		226		AF5980 (MLS), 0.6mm, 0 Notches	CF5980 ▲	FF5980 ▲
Hiace 2.5L D-4D Mk IV Diesel		08/06 →				AF5981 (MLS), 0.64mm, 2 Notches		
Hiace 2.5L D-4D Diesel		11/01 →				AF5982 (MLS), 0.68mm, 3 Notches		
Hiace Van 2.5L D-4D Diesel		11/01 →				AF5983 (MLS), 0.72mm, 4 Notches		
2KD-FTV	2494	4	92.00	Direct Injection, DOHC	65-75/ 88-102	AF5984 (MLS), 0.75mm, 5 Notches		
Hiace 2.7L		04/98 → 11/01		227		BZ170 (Graphite)		
Hiace 2.7L 4WD		04/98 →						
3RZ-FE	2694	4	95.00	Injection, DOHC	105- 112/ 143- 152			
Hiace 2.8L Diesel		08/88 → 08/95		228		BW950 (MLS)	DW950	GW950
Hiace Van 2.8L Diesel		08/89 → 08/95						
3L	2779	4	96.00	SOHC	58-61/ 79-83			

		JC658 08/85 → JC615 08/85 → JE012 [149] JE124 (x2) [149]	JN551		PA385 (x8)	NJ344 42x60x7mm, NBR NJ360 80x100x8.5mm, MVQ	
		JC615 JE012 (x2) [149]	JN551		PA385 (x8)	NJ344 42x60x7mm, NBR NJ360 80x100x8.5mm, MVQ	
HBS425 <i>(22-71030B)</i> M11x1.25x105mm (x10)		JE012 [149]			PA136 (x8)	NJ200 48x68x7mm, NBR	
HBS315 <i>(22-71020B)</i> M12x1.25x126mm (x14) M12x1.25x106mm (x4)	JE015 [149] JE017			PA138 (x8)	NJ349 32.5x46x6mm, NBR NJ344 42x60x7mm, NBR NJ354 85x105x10mm, MVQ		
HBS315 <i>(22-71020B)</i> M12x1.25x126mm (x14) M12x1.25x106mm (x4)	JC640 →08/88 JC185 →08/88 JE015 [149] JE017 08/88 →	JN567 →08/88 JN965 08/88 →	JJ150 →08/88	PA138 (x8)	NJ344 42x60x7mm, NBR →08/88 NJ349 32.5x46x6mm, NBR 08/88 → NJ344 42x60x7mm, NBR NJ354 85x105x10mm, MVQ		
HBS315 <i>(22-71020B)</i> M12x1.25x126mm (x14) M12x1.25x106mm (x4)	JE015 [149] JE017	JN965		PA138 (x8)	NJ349 32.5x46x6mm, NBR NJ344 42x60x7mm, NBR NJ354 85x105x10mm, MVQ		
HBS315 <i>(22-71020B)</i> M12x1.25x126mm (x14) M12x1.25x106mm (x4)				PA136 (x8)	NJ200 48x68x7mm, NBR		
HBS315 <i>(22-71020B)</i> M12x1.25x126mm (x14) M12x1.25x106mm (x4)		JN965		PA138 (x8)	NJ349 32.5x46x6mm, NBR NJ344 42x60x7mm, NBR NJ354 85x105x10mm, MVQ		
		JM7023 (MVQ)					
HBS425 <i>(22-71030B)</i> M11x1.25x105mm (x10)	JE015 (x2) [149]	JN954		PA425 (x8) <i>(50-306560-50)</i>	NJ200 48x68x7mm, NBR NK055 88x106x8.7mm, FPM		
	JE017	JN965		PA136 (x8)	NJ349 (x2) 32.5x46x6mm, NBR NJ344 42x60x7mm, NBR NJ215 85x105x10mm, FPM		

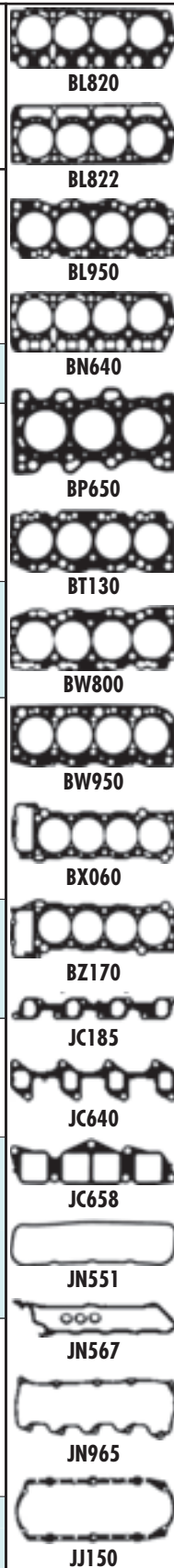









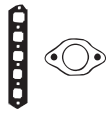

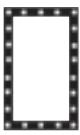

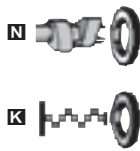































































KW/PS



Model		Year Range	Cylinders	Power (KW/PS)	Configuration	Engine Code	Accessories
Hilux 1.2L		01/69 → 12/79		229			
3K	1166	4	75.00	OHV	40/54	AJ290 (Graphite) →11/77 BD950 (Graphite) (30-028070-00) 11/77→	CJ290 ■ →07/74 CJ292 ■ 08/74→11/77 DD950 ■ 11/77→12/78 FJ290 ■ →07/74 FJ292 ■ 08/74→11/77 GD950 ■ 11/77→
Hilux 1.8L		08/83 → 08/94		230			
2Y	1812	4	86.00	OHV	57/77	BL820 (Graphite) BL822 (Graphite), 1.80mm	DL820 ■ →01/90 GL820 ■ →01/90
Hilux 2.0L		08/05 →		231			
1AZ-FSE	1998	4	86.00	Injection, DOHC	108-110/147-150		CF5781 ■ FF5781 ■
Hilux 2.0L 4WD		08/85 → 07/88		232			
3Y	1998	4	86.00	Carburettor, OHV	65/88	BL822 (Graphite), 1.80mm	
Hilux 2.0L 4WD		01/83 → 12/88		233			
3Y	1998	4	86.00	Carburettor, OHV	65/88	BL820 (Graphite) →08/85 BL822 (Graphite), 1.80mm →08/85 BN640 (Graphite) 08/85→	DL820 ■ →08/85 DN640 ■ 08/85→ GL820 ■ →08/85 GN640 ■ 08/85→
Hilux 2.2L 4WD		01/87 → 12/89		234			
4Y	2237	4	91.00	OHV	69/93	BP650 (Graphite) (30-028086-00)	DP650 ■ GP650 ■
Hilux 2.4L D Diesel		01/92 → 01/02		235			
2L	2446	4	92.00	SOHC	53-61/72-83	BL950 (Graphite) (30-026758-10) BW800 (MLS)	DW801 (21-28840-21/0) EW802 (22-27806-01/0)
Hilux 2.4L D Diesel		08/88 →		236			
Hilux 2.4L D 4WD Diesel		08/88 →		236			
2L	2446	4	92.00	SOHC	53-61/72-83	BL950 (Graphite) (30-026758-10) BW800 (MLS)	DW801 (21-28840-21/0) GW801 (20-28840-00/0)
Hilux 2.4L i 4WD		06/89 →		237			
22R	2366	4	92.00	SOHC	77-81/105-110	BM880 (Graphite) (30-028081-00)	DM881 ■ (21-28081-21/0) GM881 ■
22RE	2366	4	92.00	SOHC	84/114		
Hilux 2.4L TD 4WD Diesel		08/98 → 01/02		238			
2LT	2446	4	92.00	SOHC	63-66/85-90	BL950 (Graphite) (30-026758-10) BT130 (Fibre) (30-028104-00) BW800 (MLS)	GW800 ■
Hilux 2.4L D AWD Diesel		01/84 → 08/88		239			
2L	2446	4	92.00	SOHC	53-61/72-83	BL950 (Graphite) (30-026758-10)	DW801 (21-28840-21/0) GW801 (20-28840-00/0)
Hilux 2.5L D 4x4 Diesel		08/05 →		240			
Hilux 2.5L D4d Diesel		06/06 →		240			
Hilux 2.5L D-4D Diesel		11/01 →		240			
Hilux 2.5L D-4D 4WD Diesel		11/01 →		240			
2KD-FTV	2494	4	92.00	Direct Injection, DOHC	65-75/88-102	AF5980 (MLS), 0.6mm, 0 Notches 2KD-FTV AF5981 (MLS), 0.64mm, 2 Notches 2KD-FTV AF5982 (MLS), 0.68mm, 3 Notches 2KD-FTV AF5983 (MLS), 0.72mm, 4 Notches 2KD-FTV AF5984 (MLS), 0.75mm, 5 Notches 2KD-FTV	CF5980 ▲ FF5980 ▲

	 						                     
	JA029 (x2) →07/74 JB910 (x2) 08/74→  JE012 [149] →11/77  JE013 [149] →07/74  JE050 01/74→12/78  JE619 11/77→12/78	JM025	JH018 →12/73 JH170 01/74→11/77 JJ093 11/77→	KH066 (x8) →07/74 KJ466 (x8) 08/74→	 NJ102 38.5x58x11mm, NBR  NJ001 70x92x8.5mm, MVQ		
	 JE012 (x2) [149]  JE124 (x2) [149]	JN551			 NJ344 42x60x7mm, NBR  NJ360 80x100x8.5mm, MVQ		
	JC658  08/85→ JC615  08/85→  JE012 [149]  JE124 (x2) [149]	JN551		PA385 (x8)	 NJ344 42x60x7mm, NBR  NJ360 80x100x8.5mm, MVQ		
	JC615   JE012 (x2) [149]	JN551		PA385 (x8)	 NJ344 42x60x7mm, NBR  NJ360 80x100x8.5mm, MVQ		
	 JE015 [149]  JE017	JN965			 NJ349 32.5x46x6mm, NBR  NJ344 42x60x7mm, NBR  NJ354 85x105x10mm, MVQ		
	HBS315  [22-71020B] M12x1.25x126mm (x14) M12x1.25x106mm (x4)	 JE015 [149]  JE017	JN965		 NJ349 32.5x46x6mm, NBR  NJ344 42x60x7mm, NBR  NJ354 85x105x10mm, MVQ		
	HBS386 [22-71022B]	JC215  JC584   JE012 (x2) [149]	JN185	PA136 (x8)	 NJ243 45x68x12mm, NBR  NJ360 80x100x8.5mm, MVQ		
	HBS315  [22-71020B] M12x1.25x126mm (x14) M12x1.25x106mm (x4)	JN567			 NJ349 32.5x46x6mm, NBR  NJ344 42x60x7mm, NBR  NJ354 85x105x10mm, MVQ		
	HBS315  [22-71020B] M12x1.25x126mm (x14) M12x1.25x106mm (x4)	 JE015 [149]  JE017	JN965		 NJ349 32.5x46x6mm, NBR  NJ344 42x60x7mm, NBR  NJ354 85x105x10mm, MVQ		
		JM7023 (MVQ) 2KD-FIV					

TOYOTA



KW/PS



Hilux 2.7L 11/95 → 241					BZ170 (Graphite)		
3RZ-FE	2694	4	95.00	Injection, DOHC	105-112/143-152		
Hilux 2.8L Diesel 08/88 → 242					BW950 (MLS)	DW950	GW950
3L	2779	4	96.00	SOHC	58-61/79-83		
Hilux 3.0L Diesel 243					AY800 (MLS)		
5L	2986	4	99.50	SOHC	65/88		
Hilux 3.0L 08/89 → 11/95 244					BS370 (Graphite)	DS360	GS360
3VZ-E	2958	6	87.50	Injection, DOHC, V6	105/143 →03/94 BS360 (Graphite) →03/94	→08/92	→08/92
Innova 2.5L D4d Diesel 07/03 → 245						CF5980 ▲	FF5980 ▲
2KD-FTV	2494	4	92.00	Direct Injection, DOHC	65-75/88-102		
Isis 2.0L VVTi 07/04 → 246						CF5781	FF5781
Isis 2.0L VVTi 4x4 07/04 →							
1AZ-FSE	1998	4	86.00	Injection, DOHC	108-110/147-150		
IST 1.5L VVTi 05/04 → 247							FB5750 (20-29894-00/0)
1NZ-FE	1497	4	75.00		78/106		
Kijang 2.5L D4d Diesel 07/03 → 248						CF5980 ▲	FF5980 ▲
2KD-FTV	2494	4	92.00	Direct Injection, DOHC	65-75/88-102		
Land Cruiser 2.4L 01/90 → 05/93 249					BM880 (Graphite) (30-028081-00)	DM881 ■ (21-28081-21/0)	GM881
22R	2366	4	92.00	SOHC	77-81/105-110		
Land Cruiser 2.4L 11/84 → 12/96 250					BM880 (Graphite) (30-028081-00)	DM883 (21-28081-22/0)	
22R	2366	4	92.00	SOHC	77-81/105-110		
22RE	2366	4	92.00	SOHC	84/114		
Land Cruiser 2.4L D Diesel 11/84 → 10/85 251					BL950 (Graphite) (30-026758-10)	DL950	GL950
2L	2446	4	92.00	SOHC	53-61/72-83		
Land Cruiser 2.4L TD Diesel 10/85 → 05/90 252					BL950 (Graphite) (30-026758-10) →07/87 BT130 (Fibre) (30-028104-00) 08/87 → 07/88 BW800 (MLS) 08/88 →	DL951 (21-26758-23/0) →07/87 DT130 08/87 → 07/88 DW801 (21-28840-21/0) 08/88 →	GL951 (20-26758-01/0) →07/87 GT130 08/87 → 07/88 GW800 08/88 →
2LT	2446	4	92.00	SOHC	63-66/85-90		
Land Cruiser 2.4L TD Diesel 01/90 → 05/96 253					BW800 (MLS)	DW801 (21-28840-21/0)	GW800
2LT	2446	4	92.00	SOHC	63-66/85-90		
Land Cruiser 2.5L Cruiser Diesel 01/85 → 254					BK570 (Fibre), 1.42mm, 0 Notches (x5) (30-025008-20) BP260 (Fibre), 1.52mm, 2 Notches (x5) (30-025013-20) BK580 (Fibre), 1.62mm, 1 Notch (x5) (30-025007-20)	DK572 ▲○ [89]	GK571 ▲○ [12] [36] [89]
VM 588 HR/VM 588 HT	2494	5	88.00	Turbo			

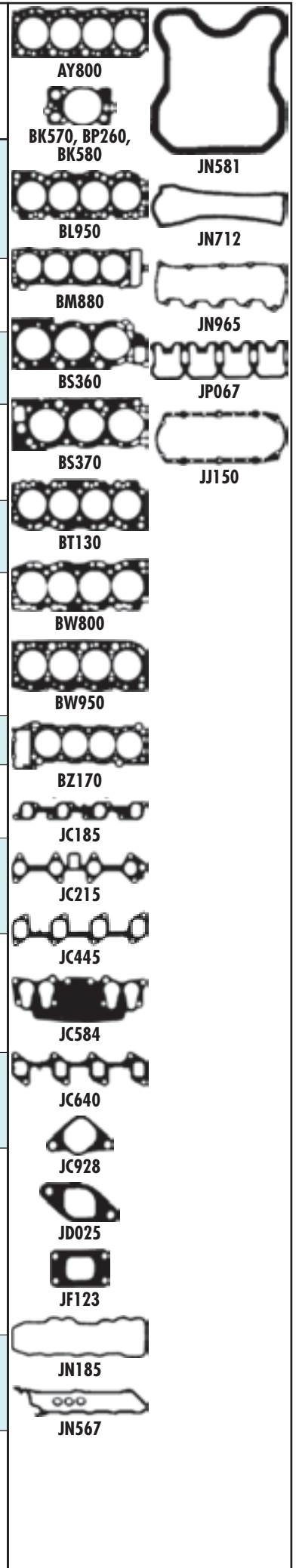
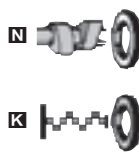
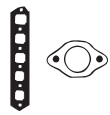

	JE015 (x2) [149]	JN954		PA425 (x8) (50.306560-50)	NJ200F 48x68x7mm, NBR NK055F 88x106x8.7mm, FPM	
	JE017	JN965		PA136 (x8)	NJ349 (x2) 32.5x46x6mm, NBR NJ344F 42x60x7mm, NBR NJ215F 85x105x10mm, FPM	
		JN965		PA138 (x8)	NJ349 32.5x46x6mm, NBR NJ344F 42x60x7mm, NBR NJ354F 85x105x10mm, MVQ	
	JC838F JF058	JN712 (x2)		PA136F (x6) PB344 (x6)	NK180 (x2) 42x55x8mm, MVQ NK050F 40x55x6mm, ACM NK015F 91x110x8.5mm, MVQ	
HBS386 (22-71022B)	JC215F JC584F JE012 (x2) [149]	JN185		PA136 (x8)	NJ243F 45x68x12mm, NBR NJ360F 80x100x8.5mm, MVQ	
HBS386 (22-71022B)						
HBS315 (22-71020B) M12x1.25x126mm (x14) M12x1.25x106mm (x4)	JC640F JC185F JE015 [149]	JN567	JJ150	PA138 (x8)	NJ344 42x60x7mm, NBR NJ344F 42x60x7mm, NBR NJ354F 85x105x10mm, MVQ	
HBS315 (22-71020B) M12x1.25x126mm (x14) M12x1.25x106mm (x4)	JC640F →07/88 JC445F →07/88 JE619 →07/87	JN567 →07/88 JN965 08/88 → HL510F →07/88	JJ150 →07/88	PA136 (x8) →07/88 PA138 (x8) 08/88 →	NJ344 42x60x7mm, NBR →07/88 NJ349 32.5x46x6mm, NBR 08/88 → NJ344F 42x60x7mm, NBR NJ354F 85x105x10mm, MVQ	
HBS315 (22-71020B) M12x1.25x126mm (x14) M12x1.25x106mm (x4)		JN965		PA138 (x8)	NJ349 32.5x46x6mm, NBR NJ344F 42x60x7mm, NBR NJ354F 85x105x10mm, MVQ	
HBS106 (22-56002B) M14x2.0x137mm (x12) M12x1.75x80mm (x5) M12x1.75x116mm (x5)	JC928F (x5) (31-025852-10) JD025F (x5) (31-025849-10) JF123 (31-027523-00)	JNS81 (x5) JP067 [230] (31-025850-10)				

TOYOTA



KW/PS



Land Cruiser 2.7L Cruiser				11/95 →	255	BZ170 (Graphite)		
3RZ-FE	2694	4	95.00	Injection, DOHC	105-112/143-152			
Land Cruiser 3.0L D-4D (KDJ120) Diesel				01/07 →	256	AG7520 (MLS), 0 Notches	CG7520▲	
Land Cruiser 3.0L D-4D Diesel				10/00 →		AG7530 (MLS), 1 Notch		
1KD-FTV	2982	4	96.00	Direct Injection, DOHC	120-122/163-166 <th>AG7540 (MLS), 2 Notches</th> <td></td> <td></td>	AG7540 (MLS), 2 Notches		
						AG7550 (MLS), 3 Notches		
						AG7560 (MLS), 4 Notches		
Land Cruiser 3.0L TD Diesel				05/93 →05/96	257	AG5230 (MLS), 0.95mm, 5 Holes		
1KZ-T	2982	4	96.00	SOHC	92/125			
Land Cruiser 3.0L TD Diesel				04/96 →	258	AG5230 (MLS), 0.95mm, 5 Holes	CG5540▲	
1KZ-TE	2982	4	96.00	SOHC	92/125			
Land Cruiser 3.4L Cruiser Diesel				09/84 →08/88	259	BJ740 (Graphite)	DJ741	GJ741
13B	3432	4	102.00	Direct Injection	66/89			
Land Cruiser 3.4L D Diesel				08/80 →12/96	260	BJ740 (Graphite)	DJ740 →08/84	GJ740 →08/84
3B	3432	4	102.00		66-72/90-98		DJ742 08/84 →	GJ742 08/84 →
Land Cruiser 3.4L i 24V				04/96 →	261	BY460 (Graphite)		
5VZ-FE	3378	6	93.50		131/178			
Land Cruiser 3.4L TD Diesel				10/85 →08/86	262	BJ740 (Graphite)		
13BT	3431	4	102.00	Direct injection	91/124			
Land Cruiser 4.0L				11/84 →08/87	263	BC260 (Graphite)	DC265■	GC265
3F	3995	6	94.00	OHV	101-115/137-156			
Land Cruiser 4.0L				08/87 →08/92	264	BC260 (Graphite)		
3F-E	3956	6	94.00		114-115/155-156			
Land Cruiser 4.0L D Diesel				08/80 →01/88	265	BK930 (Graphite)	DK940 →10/82	GK940 →10/82
2H	3980	6	91.00		74-77/101-105	BR570 (Fibre)	DK930 10/82 →10/84	GK930 10/82 →10/84
						10/84 →	DR570■ 10/84 →	GR570 10/84 →
Land Cruiser 4.0L Turbo-D Diesel				10/85 →12/89	266	BR890 (Fibre)	DR890■	GR890
12HT	3980	6	91.00		100/136			
Land Cruiser 4.2L				→04/86	267	BC260 (Graphite)	DC260■ →08/75	GC260 →08/75
2F	4229	6	94.00		88-103/120-140		DC264 11/80 →	GC261 08/75 →10/80
								GC264 11/80 →
Land Cruiser 4.2L				10/81 →01/88	268	BC260 (Graphite)	DC260■ →08/75	GC260 →08/75
2F	4229	6	94.00		88-103/120-140		DC264 11/80 →	GC261 08/75 →10/80
								GC264 11/80 →

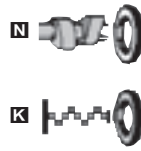
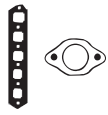

BC260



BJ740



BK930



BR570



BR890



BY460



BZ170



JC344



JC409



JC439



JM068



JN536



JN625



JN664



JN705

	JE015 (x2) [149]	JN954		PA425 (x8) (50.306560.50)	NJ200 48x68x7mm, NBR NK055 88x106x8.7mm, FPM	
		JM7023 (MVQ) 1KD-FTV				
HBS209 (22-71014B) M12x1.25x127mm (x18)						
HBS209 (22-71014B) M12x1.25x127mm (x18)						
	JE619	JM068		PA260 (x8)	NJ239 50x72x12mm, NBR NJ240 95x115x12mm, MVQ	
	JC439 →08/84 JE619	JN664 (50-026784-00) →08/88 JN827 08/88→		PA260 (x8) →08/88	NJ240 95x115x12mm, MVQ →08/88 NJ239 50x72x12mm, NBR 08/88→	
HBS394 (x16) (22-71028B)	JA5058					
				PA260 (x8)	NJ239 50x72x12mm, NBR NJ240 95x115x12mm, MVQ	
	JE015 (x2) [149]	JN625	JJ023	PA139 (x12)	NJ993 45x68x8.5mm, ACM NJ566 105x120x11mm, MVQ	
	JC344 (x6) →10/82 JC409 (x6) 11/82→	JN536 10/82→	JJ277 10/82→	PA192 (x12) →10/82 PA310 (x12) 10/82→	NJ239 50x72x12mm, NBR NJ240 95x115x12mm, MVQ	
		JN705		PA310 (x12)	NJ239 50x72x12mm, NBR NJ240 95x115x12mm, MVQ	
	JB975 JE023			KJ464 (x12) →08/75 PA021 (x12) 08/75→10/80 PA139 (x12) 11/80→	NJ243 45x68x12mm, NBR NJ055 100x120x11mm, MVQ	
	JB975 JE023			KJ464 (x12) PA021 (x12) PA139 (x12)	NJ243 45x68x12mm, NBR NJ055 100x120x11mm, MVQ	

TOYOTA



KW/PS

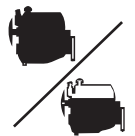

Land Cruiser 4.2L TD Diesel		01/90 → 12/97		269	AF5800 (MLS), 1.00mm, 1 Notch 07/95 → AF5810 (MLS), 1.10mm, 3 Notches 07/95 → AF5820 (MLS), 1.20mm, 5 Notches 07/95 →	CF5800▲ 07/95 →	FF5800▲ 07/95 →
1HD-T	4163	6	94.00	SOHC	118/160		
Land Cruiser 4.2L TD Diesel		01/98 →		270	AF5800 (MLS), 1.00mm, 1 Notch AF5810 (MLS), 1.10mm, 3 Notches AF5820 (MLS), 1.20mm, 5 Notches	CF5700	FF5800▲
1HD-FTE	4164	6	94.00	Direct Injection, SOHC	150/204		
Land Cruiser 4.2L TD 24V Diesel		03/95 → 12/97		271	AF5800 (MLS), 1.00mm, 1 Notch 07/95 → AF5810 (MLS), 1.10mm, 3 Notches 07/95 → AF5820 (MLS), 1.20mm, 5 Notches 07/95 →	CF5800▲ 07/95 →	FF5800▲ 07/95 →
1HD-FT	4164	6	94.00	Direct Injection, DOHC	125/170		
Land Cruiser 4.5L 24V		08/92 → 12/97		272	AF5790 (Graphite) 01/94 → 12/95	CF5792 01/94 → 12/95	FF5790 01/94 → 12/95
1FZ-FE	4477	6	100.00	DOHC	151- 158/ 205- 215		
Land Cruiser 4.7L		02/02 →		273	AF5860 (MLS)	CF5860	FF5860
Land Cruiser 4.7L V8 32V		01/98 →			AF5870 (MLS)		
2UZ-FE	4664	8	94.00	Injection, DOHC, V8	172- 175/ 234- 238		
Levin 1.6L 16v (AE860)		01/85 →		274	BN390 (Graphite) (30-028083-00)	DN390	GN390 (20-28083-00/0)
4A-GEU	1587	4	81.00	DOHC			
Liteace 1.3L		01/77 → 12/87		275	BD950 (Graphite) (30-028070-00)	DD951■ → 12/79 DD952■ DD955 1982 →	GD952 GD955 1982 →
Liteace Van 1.3L		10/79 → 10/86					
4K-C	1290	4	75.00	OHV	42-44/ 57-60		
4K	1290	4	75.00	Carburettor, OHV	42-48/ 57-65		
Liteace 1.5L		10/85 → 01/95		276	BR270 (Graphite) (30-028088-00)	DR270■ (21-28088-20/0)	GR270
Liteace Van 1.5L		05/86 → 01/95					
5K	1486	4	80.50		51-52/ 69-71		
Liteace 1.6L		10/82 → 08/88		277	BL820 (Graphite) BL822 (Graphite), 1.80mm	DL820■	GL820
1Y	1626	4	86.00	OHV	69/51		
Liteace 1.8L		12/82 → 07/85		278	BL820 (Graphite) BL822 (Graphite), 1.80mm	DL820■	GL820
2Y	1812	4	86.00	OHV	57/77		
Liteace 1.8L D Diesel		10/82 → 07/88		279	AB5000 (Graphite) (30-029229-00) → 12/86 BL300 (Graphite) (30-026751-10) → 07/83 BX010 (MLS) 01/87 →	CB5000 → 12/86 DL300 → 07/83 DX010 01/87 →	FB5000 → 12/86 GX010 01/87 →
Liteace Van 1.8L D Diesel		10/85 → 08/88					
1C	1839	4	83.00	SOHC	54/73		
Liteace 2.0L		10/85 → 07/89		280	BL820 (Graphite) BL822 (Graphite), 1.80mm		
3Y	1998	4	86.00	Carburettor, OHV	65/88		
3YC	1998	4	86.00	OHV	65/88		
Liteace 2.0L D Diesel		08/88 → 05/94		281	BR580 (Graphite) (30-028092-00)	DR581 (21-28092-21/0)	FG7650▲ GR581
Liteace Van 2.0L D Diesel		08/88 → 05/94					
2C	1974	4	86.00		51-54/ 69-73		

		HM5241 (ACM) 07/95 →		PA136 (x12)	NK216		BD950	JJ343
		HM5241 (ACM)		PA136 (x12)	NK216		BL300	
		HM5241 (ACM) 07/95 → 1HD-FT		PA136 (x12)	NK216		BL820	
		HM5240 (ACM) 01/94 → 12/95					BL822	
HBS452 (22-71027B) M10x1,25x120.0mm (x10)							BN390	
	JC578 JC579 JE106	JN603 (x2) JN604		PA425 (x16) (50-306560-50)	NJ353 35x49x6mm, NBR NJ349 32.5x46x6mm, NBR NJ001 70x92x8.5mm, MVQ		BR270	
	JB910 (x2) JE013 (x2) [149] → 12/79 JE050 JE619 JE015 [149] 01/82 →	JM025	JJ094	KJ466 (x8)	NJ102 38.5x58x11mm, NBR NJ001 70x92x8.5mm, MVQ		BR580	
	JB910 (x2) JE013 (x2) [149] JE015 [149]	JM025	JJ343	KJ466 (x8)	NJ719 38.5x58x8.5mm, NBR NJ001 70x92x8.5mm, MVQ		BX010	
	JE124 [149]	JN551		PA385 (x8)	NJ344 42x60x7mm, NBR NJ360 80x100x8.5mm, MVQ		JB910	
	JE012 (x2) [149] JE124 (x2) [149]	JN551			NJ344 42x60x7mm, NBR NJ360 80x100x8.5mm, MVQ		JC399	
HBS042 (22-71001B) M11x1.25x145mm (x10) M11x1.25x123mm (x8)	JC576 JC399 JF087	JN532		PA136 (x8)	NJ347 38x50x8mm, NBR → 01/85 NJ706 37.5x50x6mm, ACM 02/85 → NJ344 42x60x7mm, NBR NJ346 90x110x8.5mm, MVQ		JC576	
							JC578	
							JC579	
							JM025	
							JN532	
							JN551	
							JN603	
							JN604	
HBS042 (22-71001B) M11x1.25x145mm (x10) M11x1.25x123mm (x8)	JC576 JC399 JE015 [149] JE106	JM5146 JN532		PA136 (x8)	NJ706 37.5x50x6mm, ACM NJ344 42x60x7mm, NBR NJ346 90x110x8.5mm, MVQ	NJ654 [70]	JJ094	











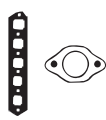

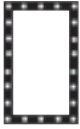



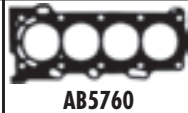









TOYOTA



KW/PS

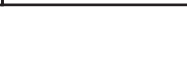
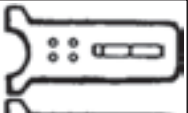

Liteace 2.2L 01/92 → 01/95 282					BP650 (Graphite) (30-028086-00)	DP651 ■	
Liteace Van 2.2L 01/92 → 01/95							
4Y-EC	2237	4	91.00		72-75/ 98-102		
Majesta 4.0L 09/99 → 08/03 283					AF5031 (MLS) ■	CF5030	■ FF5030
1UZ-FE	3969	8	87.50	DOHC, V8	180/245		
MARK II 2.0L VVTi 10/96 → 09/01 284					AG9990 (MLS)		
1G-FE	1988	6	75.00	Injection, DOHC	114/155		
Master Ace Surf 2.0L D Diesel 02/85 → 10/93 285							■ FG7650 ▲
Master Ace Surf 2.0L TD Diesel 02/85 → 10/93							
2C	1974	4	86.00		51-54/ 69-73		
2C-T	1975	4	86.00	SOHC	62/84		
Modell F 2.0L D Diesel 04/85 → 08/88 286							■ FG7650 ▲
2C	1974	4	86.00		51-54/ 69-73		
Modell F 2.0L 08/88 → 01/90 287					BL820 (Graphite)		
3Y	1998	4	86.00	Carburettor, OHV	65/88		
Modell F 2.0L Super 08/84 → 08/88 288					BL820 (Graphite)	DL820 ■	■ GL820
3Y	1998	4	86.00	Carburettor, OHV	65/88	→ 08/85	→ 08/85
3Y-C	1998	4	86.00	OHV	65/88	BL822 (Graphite), 1.80mm	■ GN640
						→ 08/85	→ 08/85
						BN640 (Graphite)	08/85 →
						08/85 →	08/85 →
Modell F 2.2L 08/87 → 01/90 289					BP650 (Graphite) (30-028086-00)	DP651 ■	
4Y-EC	2237	4	91.00		72-75/ 98-102		
MR 2 1.6L 12/87 → 12/92 290					BR750 (Graphite) (30-028093-00)	DR750 (21-28093-20/0)	■ GR750 (20-28093-00/0)
4A-F	1587	4	81.00	Carburettor, DOHC	66-70/ 90-95	→ 12/88	→ 12/88
						DR751	■ GR751
						01/89 →	01/89 →
MR 2 1.6L 16V 01/87 → 05/89 291					BR900 (Graphite)	DR900	■ GR900
4A-GZE	1587	4	81.00	Injection, DOHC, Turbo	96-127/ 131- 173		
MR 2 Coupe 1.6L 16V 11/84 → 06/90 292					BN390 (Graphite) (30-028083-00)	DN392	■ GN390
4A-GELC	1587	4	81.00		85/116	→ 05/84	(20-28083-00/0)
4A-GEL	1587	4	81.00		85-91/ 116- 124	DN390	06/84 →
						06/84 →	
MR 2 Convertible 1.8L 16V VT-i 04/00 → 293					AB5760 (MLS) (30-029887-00)	CB5760 ■ (21-29887-20/0)	■ FB5760 (20-29887-00/0)
1ZZ-FE	1794	4	79.00	DOHC	92/95/ 105		
MR 2 2.0L 12/89 → 08/92 294					BR250 (Graphite) (30-028087-00)	CD5330	■ FD5330
3S-FE	1998	4	86.00	Injection, DOHC	88-98/ 120- 133	→ 08/89	■ GR250
						BS970 (Graphite) (30-028103-00)	→ 08/89
						09/89 →	

									
		JC658 ■ JC615 ■ ⊙ JE094 ⊙ JE124 (x2) [149] ⊙ JE619	JN551		PA385 (x8)	☒ NJ344 ■ 42x60x7mm, NBR ☒ NJ360 ■ 80x100x8.5mm, MVQ			 AB5760  BL820  BL822  BN390  BN640  BP650  BR250  BR750  BR900  BS970  JC578  JC579  JC658  JC842  JC879  JC880  JC881  JD194  JN551  JN603
			HM5243 ■						 JN604  JN655  JN706
		JC658 ■ 08/85→ JC615 ■ 08/85→ ⊙ JE012 (x2) [149] ⊙ JE124 [149]	JN551		PA385 (x8)	☒ NJ344 ■ 42x60x7mm, NBR ☒ NJ360 ■ 80x100x8.5mm, MVQ			
		JC658 ■ JC615 ■ ⊙ JE094 ⊙ JE124 (x2) [149] ⊙ JE619	JN551		PA385 (x8)	☒ NJ344 ■ 42x60x7mm, NBR ☒ NJ360 ■ 80x100x8.5mm, MVQ			
		JC880 ■ →12/88 JC881 ■ →12/88 ⊙ JE015 (x2) [149]	JN706		PA425 (x16) (50.306560-50)	☒ NJ353 (x2) 35x49x6mm, NBR ☒ NJ349 ■ 32.5x46x6mm, NBR ☒ NJ001 ■ 70x92x8.5mm, MVQ			
		JC879 ■ JC579 ■ ⊙ JE015 (x2) [149] ⊙ JF087 (x2) 06/87→	JN603 (x2)		PA425 (x16) (50.306560-50)	☒ NJ353 (x2) 35x49x6mm, NBR ☒ NJ349 ■ 32.5x46x6mm, NBR ☒ NJ001 ■ 70x92x8.5mm, MVQ			
HBS203 ⊙ (22-71008B) M10x1.25x90mm (x5) M10x1.25x108mm (x5)	JC578 ■ JC579 ■ ⊙ JE106	JN603 (x2) →05/84 JN604 06/84→	JH5099		PA425 (x16) (50.306560-50)	☒ NJ353 (x2) 35x49x6mm, NBR ☒ NJ349 ■ 32.5x46x6mm, NBR ☒ NJ001 ■ 70x92x8.5mm, MVQ			
HBS385 ⊙ (22-71021B)	JD5243 ■ (31-029889-00) JD5160 ■ (31-029890-00) (MLS) ⊙ KK5495	JM5073 (50-029888-00)			PA5019 ■ (x8) (50.319497-00) PA5020 ■ (x8) (50.319496-00)	☒ NA5089 ■ 38x50x8mm, NBR (50.319498-00) ☒ NA5090 ■ 76x94x8.5mm, FPM (50.319499-00)			
HBS200 ⊙ (22-71005B) M10x1.25x94.5mm (x10)	JD194 ■ JC842 ■ →08/89 ⊙ JF087 (x2) ⊙ JE094 09/89→	JN655 (50-028189-00) (Rubber) HM5276 ■ (Rubber)	JH5098		PA425 (x16) (50.306560-50)	☒ NJ347 38x50x8mm, NBR ☒ NK214 ■ 35x63x16.5mm ☒ NJ344 ■ 42x60x7mm, NBR ☒ NJ354 ■ 85x105x10mm, MVQ	NJ693 [70]		



KW/PS



MR 2 2.0L						01/89 →	295	BR250 (Graphite) (30-028087-00) →08/89 BS970 (Graphite) (30-028103-00) 08/89 →		DR250 (21-28087-20/0) →08/89 CD5330 09/89 →	GR250 →08/89
3S-FE	1998	4	86.00	Injection, DOHC			94/128				
MR 2 2.0L Turbo						01/90 →	296	BS060 (Graphite)		DS061	
3S-GTE	1998	4	86.00	Injection, DOHC, Turbo			136- 178/ 185- 242				
MR 2 Coupe 2.0L 16V						12/89 →05/00	297	BR330 (Graphite) (30-028090-00) →02/92 BS060 (Graphite) 02/92 →		DR330 →02/92 →Eng.8xxxxxx DR332 (21-28090-21/0) →02/92 Eng.9xxxxxx →	GR330 →02/92 →Eng.8xxxxxx GR332 →02/92 Eng.9xxxxxx →
3S-GE	1998	4	86.00	Injection, DOHC			115- 129/ 156- 175				
MR 2 Coupe 2.0L 16V						12/89 →05/00	298	BR330 (Graphite) (30-028090-00) →02/92 BS060 (Graphite) 02/92 →		DR330 →02/92 →Eng.8999999 DR332 (21-28090-21/0) →02/92 Eng.9000000 →	GR330 →02/92 →Eng.8999999 GR332 →02/92 Eng.9000000 →
3S-GE	1998	4	86.00	Injection, DOHC			115- 129/ 156- 175				
MR 2 2.2L						06/91 →12/96	299	BS970 (Graphite) (30-028103-00)		DS970 (21-28103-20/0)	GS970
5S-FE	2164	4	87.00	Injection, DOHC			93-103/ 126- 140				
Noah 2.0L						12/01 →	300		CF5781	FF5781	
Noah 2.0L 4x4						12/01 →	300				
1AZ-FSE	1998	4	86.00	Injection, DOHC			108- 110/ 147- 150				
Opa 2.0L						08/00 →	301		CF5781	FF5781	
1AZ-FSE	1998	4	86.00	Injection, DOHC			108- 110/ 147- 150				
Paseo Convertible 1.5L 16V						10/96 →03/99	302	BV330 (Graphite)		DV330	GV330
Paseo Coupe 1.5L 16V						08/95 →07/99	302				
5E-FE	1496	4	74.00	MPi, DOHC			66/89				
Passo 1.0L						06/05 →	303	AG9310 (MLS)		CG9310	EG9310
Passo 1.0L 4x4						06/05 →	303				
1KR-FE	998	3	71.00	DOHC			50/68				

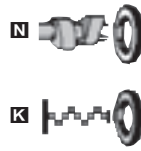
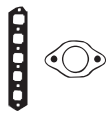

BR250



BR330



BS060



BS970



BV330



JC841



JC842



JD085



JD112



JD194



JN629

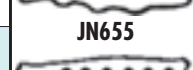

JN630

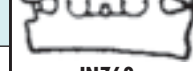

JN655



JN768



JN865

HBS200 ⊙ (22-71005B) M10x1.25x94.5mm (x10)	JD194 ■ JC842 ■ →08/89 ⊙ JF087 (x2) ⊙ JE094 09/89→	JN655 (50-028189-00) (Rubber) →08/89		PA425 (x16) (50-306560-50)	■ NJ347 38x50x8mm, NBR ■ NJ344 42x60x7mm, NBR ■ NJ354 85x105x10mm, MVQ	NJ693 [70]
HBS198 ⊙ (22-71003B) M10x1.25x93mm (x10)		JN629 (50-028187-00) JN768		PB281 (x8)	■ NJ344 42x60x7mm, NBR ■ NJ354 85x105x10mm, MVQ	
HBS198 ⊙ (22-71003B) M10x1.25x93mm (x10)	JC841 ■ →02/92 JD5786 ■▲ JC842 ■ [149] →02/94 ⊙ JE015 (x2) [149] →02/92 ⊙ JE619 →02/92	JN629 (50-028187-00) →02/92 →Eng.8xxxxxx JN630 →02/92 Eng.9xxxxxx→ JN768 02/92→ JN917 02/92→	JH5098	PA425 (x8) (50-306560-50) PB281 (x8) 02/92→08/93	■ NJ353 (x2) 35x49x6mm, NBR ■ NJ344 42x60x7mm, NBR →02/92 ■ NJ354 85x105x10mm, MVQ →02/92	NJ963 [70]
HBS198 ⊙ (22-71003B) M10x1.25x93mm (x10)	JC841 ■ →02/92 JD5786 ■▲ JC842 ■ [149] →02/94 ⊙ JE015 (x2) [149] →02/92 ⊙ JE619 →02/92	JN629 (50-028187-00) →02/92 →Eng.89999999 JN630 →02/92 Eng.90000000→ JN768 02/92→ JN917 02/92→	JH5098	PA425 (x8) (50-306560-50) PB281 (x8) 02/92→08/93	■ NJ353 (x2) 35x49x6mm, NBR ■ NJ344 42x60x7mm, NBR →02/92 ■ NJ354 85x105x10mm, MVQ →02/92	NJ963 [70]
	JD194 ■ JD112 ■ ⊙ JF087 (x2)	JN655 (50-028189-00) (Rubber)		PA425 (x16) (50-306560-50)	■ NJ347 38x50x8mm, NBR ■ NJ344 42x60x7mm, NBR ■ NJ354 85x105x10mm, MVQ	
HBS306 ⊙ (22-71016B) M9x1.25x98mm (x5) M9x1.25x84mm (x5)	JD085 ■	JN865 (50-028196-00)		PB341 (x8)	■ NJ353 35x49x6mm, NBR ■ NJ353 35x49x6mm, NBR	
	JD5845 ■ (NBR) JD5846 ■ (MLS) JD5863 ■ (Steel Elastomer)	JM7042 (ACM)			■ NA5260 38x50x6mm	



KW/PS



Pick Up 2.4L				01/81 → 12/88	304	BJ660 (Graphite) →12/84 BM880 (Graphite) (30-028081-00) 01/85 →	DM881 ■ (21-28081-21/0) 01/86 →	GJ660 →12/82 GJ661 01/83 → 12/85 GM881 01/86 →
22R	2366	4	92.00	SOHC	77-81/ 105- 110			
Pick Up 2.4L				01/84 → 06/90	305	BM880 (Graphite) (30-028081-00)	DM881 ■ (21-28081-21/0) 01/85 → 07/88 DM883 (21-28081-22/0) 08/88 →	GM880 GM881 01/85 → 07/88 GM883 08/88 →
22REC	2367	4	92.00	SOHC	82-87/ 112- 118			
Pick Up 2.4L Turbo				01/84 → 12/95	306	BM880 (Graphite) (30-028081-00)		
22RTEC	2367	4	92.00	SOHC				
Pick Up 3.0L				07/90 → 08/94	307	BS370 (Graphite) ■ →03/94 BS360 (Graphite) ■ →03/94	DS360 →08/92	GS360 →08/92
3VZ-E	2958	6	87.50	Injection, DOHC, V6	105/143			
Picnic 2.0L				01/01 → 12/01	308	AD5330 (MLS)	CD5330	FD5330
3S-FE	1998	4	86.00	Injection, DOHC	88-98/ 120- 133			
Picnic 2.0L 16V				05/96 → 12/01	309	BS970 (Graphite) (30-028103-00) →12/96 AD5330 (MLS) 12/96 →	CD5330	FD5330 12/96 →
3S-FE	1998	4	86.00	Injection, DOHC	88-98/ 120- 133			
Picnic 2.2L D Diesel				08/97 → 12/01	310	AG7670 (MLS) 3C-TE AD5340 (MLS), 1.25mm, 1 Hole (30-030183-00) AG5240 (Steel Elastomer), 1.45mm, 3 Holes	CD5340	
3C-TE	2184	4	86.00	SOHC	66/89			
Platz 1.0L VVTi				04/99 → 08/05	311		CD5381	FD5380
1SZ-FE	998	4	69.00		50/68			
Platz 1.5L VVTi				04/99 → 08/05	312			FB5750 (20-29894-00/0)
Platz 1.5L VVTi 4x4				09/02 → 08/05				
1NZ-FE	1497	4	75.00		78/106			
Porte 1.5L VVTi				10/03 →	313			FB5750 (20-29894-00/0)
1NZ-FE	1497	4	75.00		78/106			
Previa 2.0L D-4D Diesel				03/01 →	314	AD5370 (MLS), 1mm, 1 Notch AG7480 (MLS), 1.05mm, 2 Notches AG7490 (MLS), 1.1mm, 3 Notches AG7500 (MLS), 1.15mm, 4 Notches AG7510 (MLS), 1.2mm, 5 Notches	CG7490 ▲	FG7480 ▲
1CD-FTV	1995	4	82.20	Direct Injection, DOHC	66-85/ 90-116			
Previa 2.4L				05/90 → 08/00	315	BS870 (Graphite) (30-028102-00)	DS870	GS870 (20-28102-00/0)
Previa 2.4L 4WD				05/90 → 08/00				
2TZ-FE	2438	4	95.00	MPi, DOHC	97/132			
Previa 2.4L 16V				08/00 →	316	AF5840 (MLS), 0,4mm	CF5840	
2AZ-FE	2362	4	88.50	Injection, DOHC	112- 115/ 152- 156			

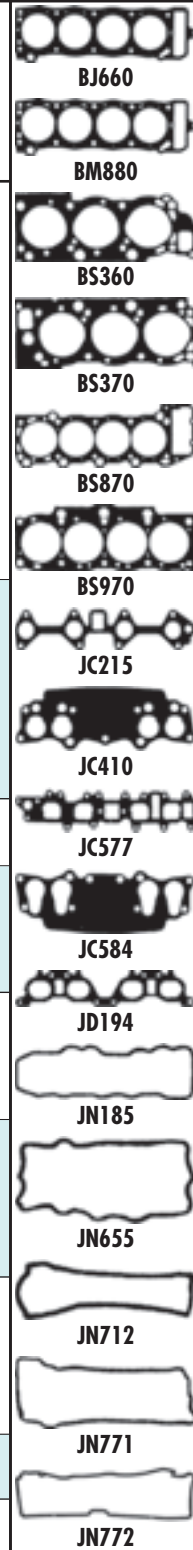
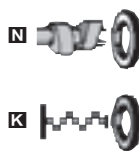
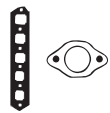

	JC577 →12/84 JC215 01/85→ JC410 →12/84 JC584 01/85→ JE013 (x2) [149] JE619 (x2) →12/84 JE012 (x2) [149] 01/85→	JN185		KJ466 (x8) →12/82 PA136 (x8) 01/83→	NJ243 45x68x12mm, NBR NJ030 80x100x12mm, ACM →12/84 NJ360 80x100x8.5mm, MVQ 01/85→	
	JC215 JC410 JC584 01/85→ JE013 (x2) [149] JE012 (x2) [149] 01/85→	JN185		PA136 (x8)	NJ243 45x68x12mm, NBR NJ360 80x100x8.5mm, MVQ	
	JC577 JE619	JN185		PA136 (x8)	NJ243 45x68x12mm, NBR NJ030 80x100x12mm, ACM	
	JC838 JF058	JN712 (x2)		PA136 (x6) PB344 (x6)	NK180 (x2) 42x55x8mm, MVQ NK050 40x55x6mm, ACM NK015 91x110x8.5mm, MVQ	
HBS200 (22-71005B) M10x1.25x94.5mm (x10)	JD194 JE094 JF087 (x2)	HM5276 (Rubber)		PA425 (x16) (50-306560-50)	NJ347 38x50x8mm, NBR NJ344 42x60x7mm, NBR NJ354 85x105x10mm, MVQ	
HBS200 (22-71005B) M10x1.25x94.5mm (x10)	JD194 JE094 JF087 (x2)	JN655 (50-028189-00) (Rubber) HM5276 (Rubber)		PA425 (x16) (50-306560-50)	NJ347 38x50x8mm, NBR NJ344 42x60x7mm, NBR NJ354 85x105x10mm, MVQ	NJ693 [70] NK215 [38]
HBS042 (22-71001B) M11x1.25x145mm (x10) M11x1.25x123mm (x8)		JM5146				NK215 [38]
HBS314 (22-71019B) M11x1.25x160mm (x8) M12x1.25x104mm (x10)	JD5901	JM5148				
HBS425 (22-71030B) M11x1.25x105mm (x10)		JN771 (50-028194-00) JN772		PB281 (x16)	NJ200 48x68x7mm, NBR NK055 88x106x8.7mm, FPM	
HBS441 [209] (22-71023B) M11x1.50x162.0mm (x10)						

TOYOTA



KW/PS



Model		Year Range	Code	CC	Cyl	Power (kW/PS)	Notes	Part	Part Code
Prius 1.5L		05/00 → 01/04	317						
1NZ-FXE	1497	4	75.00	CIH		53-57/ 72-78		AB5750 (MLS) (30-029894-00)	CB5750 (21-29894-20/0)
Probox 1.5L VVTi		07/02 →	318						
Probox 1.5L VVTi 4x4		07/02 →							FB5750 (20-29894-00/0)
1NZ-FE	1497	4	75.00			78/106			
Ractis 1.5L VVTi		07/02 →	319						
Ractis 1.5L VVTi 4x4		07/02 →							FB5750 (20-29894-00/0)
1NZ-FE	1497	4	75.00			78/106			
Raum 1.5L		05/03 →	320						
Raum 1.5L 4x4		05/03 →							FB5750 (20-29894-00/0)
1NZ-FE	1497	4	75.00			78/106			
Rav 4 1.8L VVTi		02/01 →	321						
1ZZ-FE	1794	4	79.00	DOHC		92/95/ 105		AB5760 (MLS) (30-029887-00)	CB5760 ■ (21-29887-20/0)
Rav 4 2.0L VVT-I Mk III		03/06 →	322						
1AZ-FE	1998	4	86.00	Injection, DOHC		110/150			EG6310
Rav 4 2.0L 16V		06/94 → 06/00	323						
Rav 4 Cabrio 2.0L 16V		12/97 → 06/00							
3S-FE	1998	4	86.00	Injection, DOHC		88-98/ 120- 133		BS970 (Graphite) (30-028103-00) →12/96 AD5330 (MLS) 12/96→	CD5330 FD5330 12/96→
Rav 4 2.0L D-4D 4WD Diesel		09/01 →	324						
1CD-FTV	1995	4	82.20	Direct Injection, DOHC		66-85/ 90-116		AD5370 (MLS), 1mm, 1 Notch AG7480 (MLS), 1.05mm, 2 Notches 1CD-FTV AG7490 (MLS), 1.1mm, 3 Notches 1CD-FTV AG7500 (MLS), 1.15mm, 4 Notches 1CD-FTV AG7510 (MLS), 1.2mm, 5 Notches 1CD-FTV	CG7490 ▲ FG7480 ▲
Rav 4 2.0L VVTi 4WD		06/00 →	325						
1AZ-FE	1998	4	86.00	Injection, DOHC		110/150		AF5780 (MLS) 04/01→ 1AZ-FE	CF5780 04/01→ 1AZ-FE
Rav 4 2.4L VVTi 4x4 Mk II		08/03 → 10/05	326						
2AZ-FE	2362	4	88.50	Injection, DOHC		112- 115/ 152- 156		AF5840 (MLS), 0,4mm	
Scepter 2.0L		10/86 → 09/96	327						
3S-FE	1998	4	86.00	Injection, DOHC		88-98/ 120- 133			FD5330
Scepter 2.0L TD Diesel		08/86 → 09/96	328						
2CT	1975	4	86.00	SOHC		62/84			FG7650 ▲
Sienta 1.5L		05/03 →	329						
Sienta 1.5L 4x4		05/03 →							FB5750 (20-29894-00/0)
1NZ-FE	1497	4	75.00			78/106			

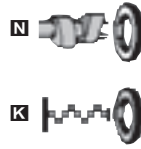
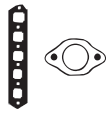

AB5750



AB5760



BS970



JD194

HBS313 Ⓞ (22-71018B) M9x1.50x143mm (x10)	JD5738 ■ (MLS) 0,5mm					
HBS385 Ⓞ (22-71021B)	JD5243 ■ (31-029889-00) JD5160 ■ (31-029890-00) (MLS) Ⓞ KK5495	JM5073 (50-029888-00)		PA5019 ■ (x8) (50-319497-00) PA5020 ■ (x8) (50-319496-00)	NA5089 ■ 38x50x8mm, NBR (50-319498-00) NA5090 ■ 76x94x8.5mm, FPM (50-319499-00)	
	JD5170 ■ JD5171 ■ (MLS) 0,4mm	JM7036 (Rubber)				
HBS200 Ⓞ (22-71005B) M10x1.25x94.5mm (x10)	JD194 ■ Ⓞ JE094 Ⓞ JF087 (x2)	HM5276 ■ (Rubber)	JH5098	PA425 (x16) (50-306560-50)	NJ347 38x50x8mm, NBR NJ344 ■ 42x60x7mm, NBR NJ354 ■ 85x105x10mm, MVQ	NJ693 [70]
HBS314 Ⓞ (22-71019B) M11x1.25x160mm (x8) M12x1.25x104mm (x10)	JD5901 ■	JM5148				
HBS441 [209] (22-71023B) M11x1.50x162.0mm (x10) 01/00→	JD5170 ■ JD5171 ■ (MLS) 0,4mm	JM7036 (Rubber)				

TOYOTA



KW/PS



Soarer 2.0L GT (GZ10/20)				01/82 →	330	BK680 (Graphite)	DK680	
1G-EU	1988	6	75.00	SOHC	77/105	(30-028077-00)		
Soarer 2.8L				12/81 → 12/85	331	BK460 (Graphite)	DK461	GK461
5M-GE	2759	6	83.00	EFI, DOHC	125/170			
Soarer Coupe 4.0L				05/92 → 09/00	332	AF5031 (MLS)	CF5030	FF5030
1UZ-FE	3969	8	87.50	DOHC, V8	180/245	AF5030 (MLS)		
Space 1.8L model F				12/82 → 07/85	333	BL820 (Graphite)	DL820	GL820
2Y	1812	4	86.00	OHV	57/77	BL822 (Graphite), 1.80mm		
Sprinter 1.3L				05/83 → 12/88	334	BM870 (Graphite)	DM871	
2A-L	1296	4	92.00	SOHC	51/55/ 69/75		05/82 →	
Sprinter 1.3L				01/84 → 12/92	335	BN200 (Graphite)	DN200	GN200
2E	1296	4	73.00	Carburettor, SOHC	53-55/ 72-75	(30-028082-00)	(21-28082-20/0)	(20-28082-00/0)
Sprinter 1.3L				01/77 → 12/87	336	BD950 (Graphite)	DD951	GD952
4K	1290	4	75.00	Carburettor, OHV	42-48/ 57-65	(30-028070-00)	→ 12/79 DD952 DD955 1982 →	GD955 1982 →
Sprinter 1.5L				03/79 → 09/90	337	BG670 (Fibre)	DL340	GL340
3A-U	1453	4	77.50	SOHC		→ 1982 BL340 (Graphite) 1983 →	(21-28079-20/0) → 09/84 DL341 10/84 →	1983 → 09/84 GL341 10/84 →
Sprinter 1.6L				01/88 → 06/92	338	BN390 (Graphite)	DN390	GN390
4A-GE	1587	4	81.00	Injection, DOHC	85-92/ 116- 125	(30-028083-00) → 05/89 BR900 (Graphite) 05/89 →	→ 05/89 DR901 05/89 →	(20-28083-00/0) → 05/89 GR901 05/89 →
Sprinter 1.6L 16V				05/92 → 10/99	339	BV370 (Graphite)	DV370	
4A-FE	1587	4	81.00	Leanburn Injection, DOHC	81/110		(21-28107-20/0)	
Sprinter 1.6L 16V				01/87 → 05/89	340	BR900 (Graphite)	DR900	GR900
4A-GZE	1587	4	81.00	Injection, DOHC, Turbo	96-127/ 131- 173		→ 05/89	→ 05/89

	JC545 (x3) JE015 [149] JE094 JE619			KJ722 (x12)	NA5187 30x52x7mm, ACM <i>(50-319492-00)</i> NJ347 38x50x8mm, NBR NJ351 45x62x8mm, NBR NJ044 75x100x13mm, MVQ	NJ963 [70]	BD950 JC559 BG670 JC578 JC579 BK460 JC879 BK680 JD175 BL340 JD176
	JC277 JC276 JF087			PA136 (x12)	NJ102 (x2) 38.5x58x11mm, NBR NJ344 42x60x7mm, NBR NJ042 48x70x12mm, NBR NJ030 80x100x12mm, ACM		BL820 JM025
		HM5243					BL822 JN356
	JE012 (x2) [149] JE124 (x2) [149]	JN551			NJ344 42x60x7mm, NBR NJ360 80x100x8.5mm, MVQ		JM025
	JC116 JE015 [149]	JN356 →08/84 JN591 08/84→		KJ722 (x8)	NJ353 35x49x6mm, NBR NJ001 70x92x8.5mm, MVQ NJ349 32.5x46x6mm, NBR		BL822 JN356
	JC559 JC558 (x2) HA397 (x2) JE015 [149]	JN598 <i>(50-026788-00)</i>		PA567 (x12)	NJ353 35x49x6mm, NBR NJ353 35x49x6mm, NBR NJ407 75x100x8.5mm, MVQ		BM870 JN551
	JB910 (x2) JE013 (x2) [149] JE015 [149] JE050 JE619 12/79→01/82	JM025	JJ094	KJ466 (x8)	NJ102 38.5x58x11mm, NBR NJ001 70x92x8.5mm, MVQ		BN200 JN598
	JC116 JE013 (x2) [149] →12/82 JE015 [149] JE012 [149] 01/83→09/84	JN356		KJ722 (x8)	NJ353 35x49x6mm, NBR NJ349 32.5x46x6mm, NBR NJ001 70x92x8.5mm, MVQ		BN390 JN603
	JC578 →05/89 JC879 05/89→ JC579 JE015 (x2) [149] →05/89 JE106 →05/89 JE619 (x2) →05/89 JF058 (x2) 05/89→ JF087 (x2) 05/89→	JN603 (x2) JN604 →05/89 JN876 05/89→		PA425 (x16) <i>(50-306560-50)</i>	NJ353 35x49x6mm, NBR NJ349 32.5x46x6mm, NBR NJ001 70x92x8.5mm, MVQ		HA397 JN876
HBS203 © <i>(22-710088)</i> M10x1.25x90mm (x5) M10x1.25x108mm (x5)	JD175 JD176	JN904		PA425 (x16) <i>(50-306560-50)</i>	NJ353 (x2) 35x49x6mm, NBR NJ349 32.5x46x6mm, NBR NJ001 70x92x8.5mm, MVQ		JB910 JC116 JC276
	JC879 06/89→ JC579 JE015 (x2) [149] →05/89 JF087 (x2) 06/87→	JN603 (x2) JN879 (x2) 06/89→		PA425 (x16) <i>(50-306560-50)</i>	NJ353 (x2) 35x49x6mm, NBR NJ349 32.5x46x6mm, NBR NJ001 70x92x8.5mm, MVQ		JC545 JC558











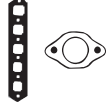

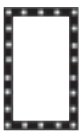

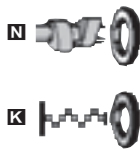













































































TOYOTA



KW/PS



Sprinter 1.6L 16V GT		11/84 → 06/90		341	BN390 (Graphite) (30-028083-00)	DN390 06/84 → 01/87	GN390 (20-28083-00/0) 06/84 → 01/87
4A-GEU	1587	4	81.00	DOHC			
Sprinter 2.0L D Diesel		04/95 → 11/00		342			FG7650 ▲
2C	1974	4	86.00		51-54/ 69-73		
Starlet 1.0L		12/89 → 12/92		343	BN530 (Graphite) (30-026759-10)	DN530	GN530 (20-26759-00/0)
1E	999	4	70.50	Carburettor, SOHC	40/54		
Starlet 1.0L		10/84 → 12/89		344	BN530 (Graphite) (30-026759-10)	DN530	GN530 (20-26759-00/0)
1EL	999	4	70.50	Carburettor, SOHC	40/54		
Starlet 1.3L		10/84 → 12/89		345	BN200 (Graphite) (30-028082-00)	DN200 (21-28082-20/0)	GN200 (20-28082-00/0)
2E-LC	1295	4	73.00	SOHC	55/75		
Starlet 1.3L		04/96 → 03/99		346	BV330 (Graphite)	DV331	
4E-FE	1331	4	74.00	MPI, SOHC	55-65/ 75-88		
Starlet 1.3L		05/81 →		347	BD950 (Graphite) (30-028070-00)	DD955 → 12/83	GD955 → 12/83
4K-C	1290	4	75.00	OHV	42-44/ 57-60		
Starlet 1.3L 12V		12/89 → 03/96		348	BN200 (Graphite) (30-028082-00)	DN200 (21-28082-20/0)	
2E	1296	4	73.00	Carburettor, SOHC	53-55/ 72-75		
2E-E	1296	4	73.00	MPI, SOHC	74/100		
Starlet 1.5L D Diesel		12/86 → 03/96		349	AG7570 (MLS), 1.45mm, 1 Notch AG7580 (MLS), 1.55mm, 2 Notches AG7590 (MLS), 1.65mm, 3 Notches	CG7570	FG7570
1N	1453	4	74.00		40/54		
Stout 2.2L		01/88 →		350	BP650 (Graphite) (30-028086-00)	DP650 ■	GP650
4Y	2237	4	91.00	OHV	69/93		
Succeed 1.4L D4d Diesel		07/02 →		351	AG7600 (MLS), 0.85mm AG7610 (MLS), 0.90mm AG7620 (MLS), 0.95mm	CG7600 ▲	FG7600 ▲
1ND-TV	1364	4	73.00	Direct Injection, SOHC	55-66/ 75-90		
Succeed 1.5L VVTi		07/02 →		352			FB5750 (20-29894-00/0)
Succeed 1.5L VVTi 4x4		07/02 →					
1NZ-FE	1497	4	75.00		78/106		
Supra Coupe 3.0L 24V		01/86 → 08/88		353	BR300 (Graphite)	DR301	GR301
7M-GE	2954	6	83.00	DOHC	150/204		
Supra Coupe 3.0L i Bi-Turbo		05/93 → 08/98		354	AF5850 (MLS)	CG8300	
2JZ-GTE	2997	6	86.00	DOHC	243/330	2JZ-GTE	
Supra Coupe 3.0L Turbo		09/87 → 05/93		355	BR300 (Graphite)	DR300	GR300
7M-GTE	2954	6	83.00	DOHC	150/204		
T100 2.7L		11/95 →		356	BZ170 (Graphite)		
3RZ-FE	2694	4	95.00	Injection, DOHC	105- 112/ 143- 152		

								
		JC578  JC579  ⊙JE106	JN603 (x2) JN604 06/84 →		PA425 (x16) (50-306560-50)	 NJ353 35x49x6mm, NBR  NJ349  32.5x46x6mm, NBR  NJ001  70x92x8.5mm, MVQ		 JN603 BD950  BN200  JN604 BN390  JN631 BN530  JN865 BP650  JJ094 BR300  BV330  BZ170  HA397  JB910  JC276  JC558  JC559  JC578  JC579  JC739  JD085  JM025  JN551  JN598
HBS197  (22-71002B) M9x1.25x98mm (x10)	JC559  JC558  (x2) HA397  ⊙JF087	JN598 (50-026788-00)		PA567 (x12) →02/90 PB340  (x4) 02/90 → PA425  (x8) (50-306560-50) 02/90 →	 NJ353 35x49x6mm, NBR  NJ353  35x49x6mm, NBR  NJ407  75x100x8.5mm, MVQ →10/90			
HBS197  (22-71002B) M9x1.25x98mm (x10)	JC559  JC558  (x2) ⊙JF087	JN598 (50-026788-00)		PA425 (x12) (50-306560-50) →01/86 PA567 (x12) 01/86 →	 NJ353 35x49x6mm, NBR  NJ353  35x49x6mm, NBR  NJ407  75x100x8.5mm, MVQ			
HBS197  (22-71002B) M9x1.25x98mm (x10)	JC559  JC558  (x2) HA397  ⊙JE015 [149]	JN598 (50-026788-00)		PA567 (x12)	 NJ353  35x49x6mm, NBR	NJ654 [70]		
HBS306  (22-71016B) M9x1.25x98mm (x5) M9x1.25x84mm (x5)	JD085 	JN865 (50-028196-00) →07/93			 NJ353 35x49x6mm, NBR			
	JB910 (x2) ⊙JE013 [149] →12/83 ⊙JE015 [149] →12/83	JM025	JJ094	KJ466 (x8)	 NJ102  38.5x58x11mm, NBR  NJ001  70x92x8.5mm, MVQ			
HBS197  (22-71002B) M9x1.25x98mm (x10)	JC558  (x2) ⊙JF087	JN598 (50-026788-00)		PB340  (x4) PA425  (x8) (50-306560-50)	 NJ353 35x49x6mm, NBR			
		JM7024 (NBR)			 NA5260 38x50x6mm			
	JC615  ⊙JE012 (x2) [149]	JN551		PA385 (x8)	 NJ344  42x60x7mm, NBR  NJ360  80x100x8.5mm, MVQ  NA5260 38x50x6mm			
	JC739  JC276  ⊙JE015 (x2) [149]	JN631 (x2)		PA425 (x24) (50-306560-50)	 NJ353 (x2) 35x49x6mm, NBR  NJ344  42x60x7mm, NBR  NJ645  52x70x8.5mm, ACM  NJ030  80x100x12mm, ACM			
HBS450 (22-71026B) M11x1.25x91mm (x14)		HM5273 						
	⊙JE015 (x2) [149]	JN954		PA425  (x8) (50-306560-50)	 NJ200  48x68x7mm, NBR  NK055  88x106x8.7mm, FPM			











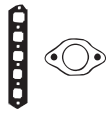

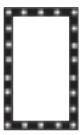

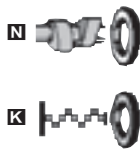



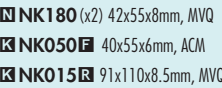
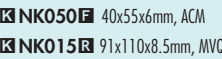
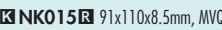







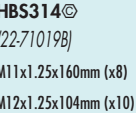



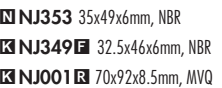
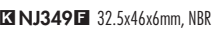
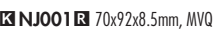



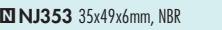



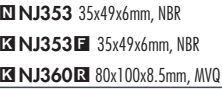
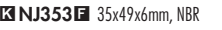





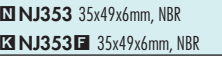
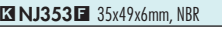

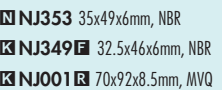
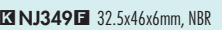
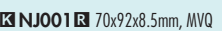

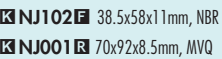
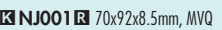
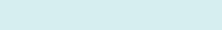

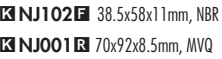
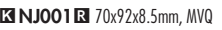



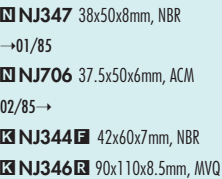
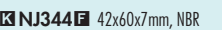
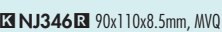

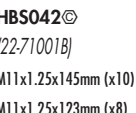

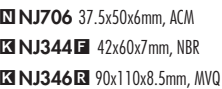
TOYOTA



KW/PS

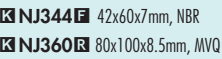

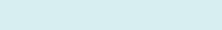
T100 3.0L		07/90 → 08/94		357	BS370 (Graphite)	DS360	GS360
3VZ-E	2958	6	87.50	Injection, DOHC, V6	105/143 →03/94 BS360 (Graphite) →03/94	→08/92	→08/92
Tacoma 2.7L 4WD		11/95 →		358	BZ170 (Graphite)		
3RZ-FE	2694	4	95.00	Injection, DOHC	105- 112/ 143- 152		
Tarago 2.0L TDi Diesel		10/03 → 12/05		359	AD5370 (MLS), 1 mm, 1 Notch AG7480 (MLS), 1.05mm, 2 Notches AG7490 (MLS), 1.1mm, 3 Notches AG7500 (MLS), 1.15mm, 4 Notches AG7510 (MLS), 1.2mm, 5 Notches	CG7490 ▲	FG7480 ▲
1CD-FTV	1995	4	82.20	Direct Injection, DOHC	66-85/ 90-116		
Tercel 1.3L		03/79 → 01/88		360	BM870 (Graphite)	DG690 ■	
2A	1295	4	76.00	SOHC	05/82→	→04/82 DM871 05/82→08/84	
Tercel 1.5L		05/88 →		361	BN200 (Graphite)		
3E-E	1456	4	73.00	SOHC	(30-028082-00)		
Tercel 1.5L		01/86 → 12/90		362	BN200 (Graphite)		GN201
3E	1456	4	73.00	SOHC	(30-028082-00)		
Tercel 1.5L 16V		01/91 → 07/95		363	BV330 (Graphite)	DV330	GV330
5E-FE	1496	4	74.00	MPI, DOHC	66/89		
Tercel 1.5L 4WD		10/82 → 01/88		364	BL340 (Graphite)		GL343
3A	1453	4	77.50	SOHC	52/71		
Tercel 1.5L 4WD		05/86 → 01/88		365	BL340 (Graphite)		GL343
3A-C	1452	4	77.50	SOHC	50-52/ 68-71		
Town Ace 2.0L D Diesel		01/92 → 04/95		366			FG7650 ▲
2C	1974	4	86.00		51-54/ 69-73		
Townace 1.3L		01/85 →		367	BD950 (Graphite)	DD955	GD955
4KJ	1290	4	75.00	OHV	(30-028070-00) 40-46/ 54-63		
Townace 1.3L		01/77 → 12/87		368	BD950 (Graphite)	DD951 ■	GD952
4K	1290	4	75.00	Carburettor, OHV	(30-028070-00) 42-48/ 57-65	→12/79 DD952 ■ DD955 1982→	GD955 1982→
Townace 1.8L Diesel		05/83 →		369	AB5000 (Graphite)	CB5000	FB5000
1CL	1839	4	83.00	SOHC	(30-029229-00) →05/85 BX010 (MLS) 05/85→	→05/85 DX010 05/85→	→05/85 GX010 05/85→
Townace 2.0L Diesel		08/92 → 01/96		370	BR580 (Graphite)	DR581	GR581
2C	1974	4	86.00		(30-028092-00) 51-54/ 69-73	(21-28092-21/0)	
Townace 2.0L		01/87 →		371	BP650 (Graphite)	DP651 ■	
3Y-EU	1998	4	86.00	Carburettor, OHV, V4	(30-028086-00)		

									
		JC838  ☉JF058	JN712 (x2)		PA136  (x6) PB344  (x6)	 NK180 (x2) 42x55x8mm, MVQ NK050  40x55x6mm, ACM NK015  91x110x8.5mm, MVQ		 BD950	 JN356
		☉JE015 (x2) [149]	JN954		PA425  (x8) (50.306560-50)	 NJ200  48x68x7mm, NBR NK055  88x106x8.7mm, FPM		 BL340	 JN532
HBS314  (22-71019B) M11x1.25x160mm (x8) M12x1.25x104mm (x10)		JD5901 	JM5148					 BM870	 JN551
		JC116 ☉JE013 (x2) [149] →04/82 ☉JE015 [149] 05/82→	JN356 →08/84 JN591 08/84→		KJ722 (x8)	 NJ353 35x49x6mm, NBR NJ349  32.5x46x6mm, NBR NJ001  70x92x8.5mm, MVQ		 BN200	 JN591
		☉JE015 [149]	JN598 (50-026788-00)		PB340  (x4) PA425  (x8) (50.306560-50)	 NJ353 35x49x6mm, NBR		 BP650	 JN598
		JC559  ☉JE015 [149]	JN598 (50-026788-00)		PA567 (x12)	 NJ353 35x49x6mm, NBR NJ353  35x49x6mm, NBR NJ360  80x100x8.5mm, MVQ		 BR580	 JN712
		JD085 	JN865 (50-028196-00)		PB341  (x8)	 NJ353 35x49x6mm, NBR NJ353  35x49x6mm, NBR		 BS360	 JN865
		JC116 ☉JE012 (x2) [149] ☉JE015 [149]	JN591		KJ722 (x8)	 NJ353 35x49x6mm, NBR NJ349  32.5x46x6mm, NBR NJ001  70x92x8.5mm, MVQ		 BS370	 JJ094
		JB910 (x2) ☉JE013 [149]	JM025	JJ094	KJ466 (x8)	 NJ102  38.5x58x11mm, NBR NJ001  70x92x8.5mm, MVQ		 BV330	
		JB910 (x2) ☉JE013 (x2) [149] ☉JE015 [149] ☉JE050 ☉JE619	JM025	JJ094	KJ466 (x8)	 NJ102  38.5x58x11mm, NBR NJ001  70x92x8.5mm, MVQ		 BX010	
		JC576  JC399  ☉JF087	JN532		PA136 (x8)	 NJ347 38x50x8mm, NBR →01/85 NJ706 37.5x50x6mm, ACM 02/85→ NJ344  42x60x7mm, NBR NJ346  90x110x8.5mm, MVQ		 BZ170	
HBS042  (22-71001B) M11x1.25x145mm (x10) M11x1.25x123mm (x8)		JC576  JC399  ☉JE015 [149] ☉JE106	JN532		PA136 (x8)	 NJ706 37.5x50x6mm, ACM NJ344  42x60x7mm, NBR NJ346  90x110x8.5mm, MVQ	NJ654 [70]	 JB910	
		JC658  JC615  ☉JE094 ☉JE124 (x2) [149] ☉JE619	JN551		PA385 (x8)	 NJ344  42x60x7mm, NBR NJ360  80x100x8.5mm, MVQ		 JC116	

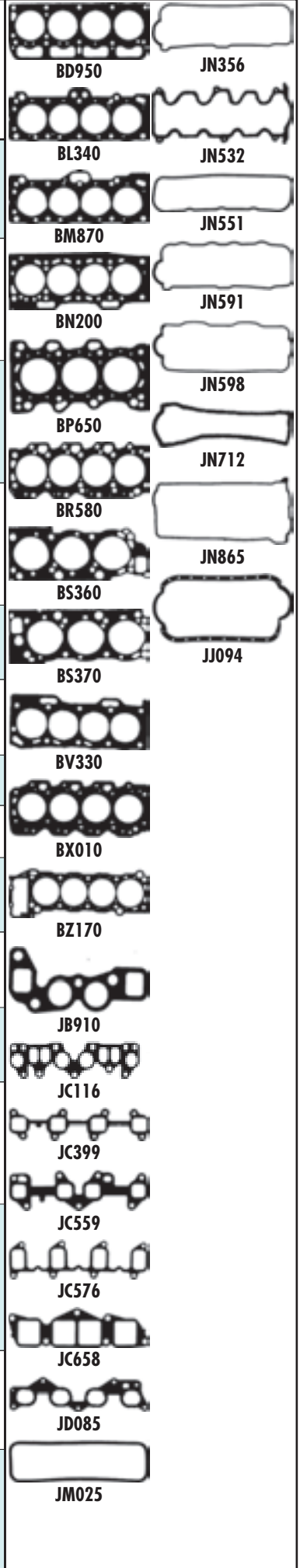

TOYOTA



KW/PS

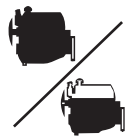

Model	Year Range	Power (KW/PS)	Engine Type	Accessories
Townace 2.0L Diesel	08/92 → 01/96	372	BX020 (MLS), 1.35mm	DR580 DX020 GX020
2C-T	1975 4 86.00 SOHC, Turbo	62/84		
Toyoace 2.4L Diesel	08/88 →	373	BW800 (MLS)	DW801 (21-28840-21/0) GW801 (20-28840-00/0)
2L	2446 4 92.00 SOHC	53-61/ 72-83		
Toyoace 2.8L Diesel	08/88 →	374	BW950 (MLS)	DW950 GW950
3L	2779 4 96.00 SOHC	58-61/ 79-83		
Toyoace 3.0L Diesel	01/85 →	375	BR950 (Graphite)	DR951 GR951
11B	2977 4 95.00 Injection	59/80		
Trueno 1.6L 16v GT (AE86)	11/84 → 06/90	376	BN390 (Graphite)	DN390 GN390 (20-28083-00/0)
4A-GEU	1587 4 81.00 DOHC		(30-028083-00)	
Vios 1.5L	07/01 →	377		FB5750 (20-29894-00/0)
1N2-FE	1497 4 75.00	78/106		
Vista 1.8L (SV10)	10/82 → 10/86	378	BK670 (Graphite)	DK670 GK671 10/82 →
1S	1832 4 80.50	66/89		
Vista 1.8L D Diesel	08/83 → 08/85	379	AB5000 (Graphite)	CB5001 FB5001 (30-029229-00)
1C-TL	1839 4 83.00 SOHC, Turbo	54/73		
Vista 2.0L	10/86 → 06/91	380		FD5330
3S-FE	1998 4 86.00 Injection, DOHC	88-98/ 120- 133		
Vista 2.0L D Diesel	07/91 → 09/98	381		FG7650 ▲
Vista 2.0L TD Diesel	11/88 → 06/91			
2C-T	1975 4 86.00 SOHC	62/84		
Vitz 1.0L	01/98 →	382		CD5380
1SZ-FE	998 4 69.00	50/68		
Vitz 1.0L VVTi	01/99 → 03/03	383		CD5381 FD5380
1SZ-FE	998 4 69.00	50/68		
Vitz 1.0L VVTi	11/05 →	384	AG9310 (MLS)	CG9310 EG9310
1KR-FE	998 3 71.00 DOHC	50/68		
Vitz 1.3L	01/98 →	385	AB5750 (MLS)	CB5750 (21-29894-20/0) FB5750 (20-29894-00/0)
2NZ-FE	1299 4 75.00	66/89	(30-029894-00)	
Vitz 1.4L D Diesel	04/03 → 08/05	386	AG7600 (MLS), 0.85mm	CG7600 ▲ FG7600 ▲
1ND-TV	1364 4 73.00 Direct Injection, SOHC	55-66/ 75-90	AG7610 (MLS), 0.90mm AG7620 (MLS), 0.95mm	
Vitz 1.5L	04/03 → 08/05	387		FB5750 (20-29894-00/0)
1N2-FE	1497 4 75.00	78/106		
Will 1.3L VVTi	05/01 →	388		FB5750 (20-29894-00/0)
2NZ-FE	1299 4 75.00	66/89		
Will 1.5L VVTi 4WD	03/01 →	389		FB5750 (20-29894-00/0)
1N2-FE	1497 4 75.00	78/106		

HBS042 ⊙ <i>(22-71001B)</i> M11x1.25x145mm (x10) M11x1.25x123mm (x8)	JC444 ■ ⊙JF058	JN532		PA136 (x8)	□NJ706 37.5x50x6mm, ACM □NJ344■ 42x60x7mm, NBR □NJ346■ 90x110x8.5mm, MVQ	NJ654 [70]	 AB5750 BK670 BN390 BR950 BW800 BW950 BX020
HBS315 ⊙ <i>(22-71020B)</i> M12x1.25x126mm (x14) M12x1.25x106mm (x4)	⊙JE017	JN965			□NJ349 32.5x46x6mm, NBR □NJ344■ 42x60x7mm, NBR □NJ354■ 85x105x10mm, MVQ		 JC402 JC444 JC576 JC578 JC579
	⊙JE017	JN965		PA136 (x8)	□NJ349 (x2) 32.5x46x6mm, NBR □NJ344■ 42x60x7mm, NBR □NJ215■ 85x105x10mm, FPM		
	⊙JE048 (x2) ⊙JE619	JM068		PA260 (x8)	□NJ239■ 50x72x12mm, NBR □NJ240■ 95x115x12mm, MVQ		 JM068 JN469 JN532 JN603
	JC578 ■ JC579 ■ ⊙JE106	JN603 (x2) JN604		PA425 (x16) <i>(50-306560-50)</i>	□NJ353 35x49x6mm, NBR □NJ349■ 32.5x46x6mm, NBR □NJ001■ 70x92x8.5mm, MVQ		 JM5149 JM7042 JM5072
	JC402 ⊙JE012 [149] ⊙JE106	JN469		KJ466 (x8)	□NJ347 38x50x8mm, NBR □NJ344■ 42x60x7mm, NBR □NJ354■ 85x105x10mm, MVQ	NJ963 [70]	 JM5149 JM7042 JM5072
	JC576 ■ JC444 ■ ⊙JE619	JN532		PA136 (x8)	□NJ347 38x50x8mm, NBR →01/85 □NJ706 37.5x50x6mm, ACM 01/85→ □NJ344■ 42x60x7mm, NBR □NJ346■ 90x110x8.5mm, MVQ		 JM5149 JM7042 JM5072
							 JM5149 JM7042 JM5072
							 JM5149 JM7042 JM5072
HBS312 ⊙ <i>(22-71017B)</i> M9x1.25x84mm (x10)		JM5149 (Rubber)					 JM5149 JM7042 JM5072
	JD5845 ■ (NBR) JD5846 ■ (MLS) JD5863 ■ (Steel Elastomer)	JM7042 (ACM)			□NA5260 38x50x6mm		 JM5149 JM7042 JM5072
HBS313 ⊙ <i>(22-71018B)</i> M9x1.50x143mm (x10)		JM5072 <i>(50-029895-00)</i> (Rubber)					 JM5149 JM7042 JM5072
					□NA5260 38x50x6mm		 JM5149 JM7042 JM5072
							 JM5149 JM7042 JM5072
							 JM5149 JM7042 JM5072



KW/PS



Wish 2.0L Zi					04/03 →	390		CF5781	FF5781
1AZ-FSE	1998	4	86.00	Injection, DOHC		108-110/ 147-150			
Yaris 1.0L VVT-i					01/06 →	391	AG9310 (MLS)	CG9310	EG9310
1KR-FE	998	3	71.00	DOHC		50/68			
Yaris 1.0L 16V					04/99 →	392	AD5380 (MLS)	CD5380	FD5380
1SZ-FE	998	4	69.00			50/68	1SZ-FE	→12/01 CD5381 01/02 →	
Yaris 1.3L					04/02 →	393			
2SZ-FE	1298	4	72.00	DOHC		64/87			
Yaris 1.3L 16V					11/99 →	394	AB5750 (MLS)	CB5750	FB5750
Yaris Verso 1.3L					11/99 →		(30-029894-00)	(21-29894-20/0)	(20-29894-00/0)
2NZ-FE	1299	4	75.00			66/89			
Yaris 1.3L VVT-i					01/06 →	395			
2SZ-FE	1298	4	72.00	DOHC		64/87			
Yaris 1.4L D-4D Diesel					12/01 →	396	AG7600 (MLS), 0.85mm	CG7600▲	FG7600▲
Yaris Verso 1.4L D-4D Diesel					12/01 →		AG7610 (MLS), 0.90mm AG7620 (MLS), 0.95mm		
1ND-TV	1364	4	73.00	Direct Injection, SOHC		55-66/ 75-90			
Yaris D-4D Diesel					01/06 →	397	AG7600 (MLS), 0.85mm AG7610 (MLS), 0.90mm AG7620 (MLS), 0.95mm	CG7600▲	FG7600▲
1ND-TV	1364	4	73.00	Direct Injection, SOHC		55-66/ 75-90			
Yaris 1.5L					11/05 →	398			FB5750 (20-29894-00/0)
1NZ-FE	1497	4				80/109 78/106			
1NZ-FE	1497	4	75.00						
Yaris 1.5L TS					01/03 →	399	AB5750 (MLS)	CB5750	FB5750
Yaris 1.5L VVT-i TS					04/01 →		(30-029894-00)	(21-29894-20/0)	(20-29894-00/0)
Yaris Verso 1.5L					03/00 →				
1NZ-FE	1497	4	75.00			78/106			

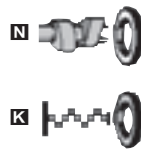
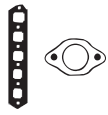

AB5750

	JD5845 ■ (NBR) JD5846 ■ (MLS) JD5863 ■ (Steel Elastomer)	JM7042 (ACM)			NA5260 38x50x6mm	
HBS312 ⊕ (22-71017B) M9x1.25x84mm (x10)	JD5836 ■ JD5837 ■ (MLS) 0,5mm	JM5149 (Rubber)				
HBS312 ⊕ (22-71017B) M9x1.25x84mm (x10) HBS313 ⊕ (22-71018B) M9x1.50x143mm (x10)	JD5159 ■ JD5738 ■ (MLS) 0,5mm	JM5149 (Rubber)				
HBS312 ⊕ (22-71017B) M9x1.25x84mm (x10) HBS313 ⊕ (22-71018B) M9x1.50x143mm (x10)	JD5159 ■ JD5738 ■ (MLS) 0,5mm	JM5072 (50-029895-00) (Rubber)				
	JD5159 ■ JD5738 ■ (MLS) 0,5mm					
		JM5288 1ND-TV			NA5260 38x50x6mm	
					NA5260 38x50x6mm	
HBS312 ⊕ (22-71017B) M9x1.25x84mm (x10) HBS313 ⊕ (22-71018B) M9x1.50x143mm (x10)	JD5159 ■ JD5738 ■ (MLS) 0,5mm	JM5072 (50-029895-00) (Rubber)				



KW/PS



Model	CC	Cyl	Stroke	Configuration	Year Range	Power (KW/PS)	Engine Type	Accessories	
1500 1.5L TC	1493	4			04/75 → 12/77	53/72	AK260 (Fibre) [249]	CK261 <input type="checkbox"/> <input type="radio"/> Ch.TC25001 →	EG091 [12]
2.5 PI 2.5L					01/68 → 12/75		AG900 (Fibre) [231]	CG902 <input type="checkbox"/> <input type="radio"/>	EE350 [12]
2.5 PI 2.5L Mki					01/68 → 12/75		→08/71 →Eng.MG50000E	→08/71 →Eng.MG50000E	
25PI	2498	6	74.60			90-100/ 122- 136	AK280 (Fibre) [249]	CK280 <input type="checkbox"/> <input type="radio"/>	
							09/71 → Eng.MG50001E →	09/71 → Eng.MG50001E →	
Acclaim 1.3L					01/82 → 12/85		BG710 (Graphite)		
EJ	1335	4	72.00	SOHC		51/70			
Acclaim 1.3L					01/81 → 12/84		BC630 (Graphite)	DC635 →Eng.2000000	EC633
EN4	1335	4	72.00	SOHC				DC636 Eng.2000000 →	
Dolomite 1.5L					01/72 → 12/81		AK260 (Fibre) [249]	CK263 <input type="checkbox"/> <input type="radio"/>	EG091 [12]
FWD WB30000E →	1493	4	73.64						
GT6 2.0L					01/66 → 12/73		AG900 (Fibre) [231]	CG902 <input type="checkbox"/> <input type="radio"/>	EE350 [12]
	1998	6	74.68				01/68 → 08/71	01/68 → 08/71	
							AK280 (Fibre) [249]		
							09/71 → 12/73		
Herald 13/60					01/67 → 12/71		AK520 (Fibre) [231]	CK525 <input type="checkbox"/> <input type="radio"/>	
	1269	4				46/62			
Spitfire Convertible 1.3L MkiV					01/71 → 12/72		AK260 (Fibre) [249]	CK260 <input type="checkbox"/> <input type="radio"/>	EG091 [12]
FM3	1296	4	73.70			48-55/ 65-76			
Spitfire 1.5L (US Version)					01/72 → 12/80		AK260 (Fibre) [249]	CK261 <input type="checkbox"/> <input type="radio"/>	EG091 [12]
	1493	4	73.64						
Stag 3.0L					01/70 → 12/77			CX650 <input type="checkbox"/> <input type="radio"/>	EH700 [12]
	2997	8				107/145			
Toledo 1.5L					01/72 → 12/77		AK520 (Fibre) [231]	CK525 <input type="checkbox"/> <input type="radio"/>	EG091 [12]
Toledo 1.5L TC					01/71 → 12/77		→08/71 →Eng.DG25000E →Eng.DM5000E →Eng.DS5000E	→08/71 →Eng.DG25000E →Eng.DM5000E →Eng.DS5000E	
	1493	4				49/66 51/69	AK260 (Fibre) [249]	CK261 <input type="checkbox"/> <input type="radio"/>	
	1493	4					08/71 → Eng.DG25001E → Eng.DM5001E → Eng.DS5001E →	08/71 → Eng.DG25001E → Eng.DM5001E → Eng.DS5001E →	
TR 250 2.5L					01/67 → 12/69		AG900 (Fibre) [231]	CG901	EE350 [12]
	2498	6	74.70						
TR 4 Convertible 2.1L					12/65 → 12/67		AE330 (Fibre)	CE330 <input type="checkbox"/> <input type="radio"/>	EC510 [12]
	2138	4				76/104			
TR 5 Convertible 2.5L PI					01/67 → 12/68		AG900 (Fibre) [231]	CG902 <input type="checkbox"/> <input type="radio"/>	EE350 [12]
	2498	6				105/143			
TR 6 Convertible 2.5L					01/72 → 12/76		AK280 (Fibre) [249]	CK280 <input type="checkbox"/> <input type="radio"/>	EE350 [12]
CF1	2498	6	74.70			83-90/ 113- 122	Eng.CC75001E →	Eng.CC75001E →	
TR 6 Convertible 2.5L PI					01/69 → 12/76		AG900 (Fibre) [231]	CG902 <input type="checkbox"/> <input type="radio"/>	EE350 [12]
	2498	6				105/143	→08/71 →Eng.CP75000E	→08/71 →Eng.CP75000E	
							AK280 (Fibre) [249]	CK280 <input type="checkbox"/> <input type="radio"/>	
							09/71 → Eng.CP75001E →	09/71 → Eng.CP75001E →	

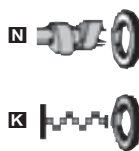
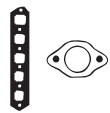

AE330



JH370



AG900



JH445



AK260



AK280



AK520



BC630



BG710



JA502



JA510



JA625



JA626



JB765



JC414



JE331



JM261



JM477



JN512



JN583

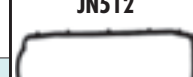

JH171

	JA502 ⊕JE331	JM261	JH445		☒ NA774 73x92.1x9.5mm, MVQ	JR147 [11]
	JA510	JM477	JH370		☒ NA774 73x92.1x9.5mm, MVQ	JR147 [11]
	⊕JE625 →12/82		JH171	PA288 ☒ (x4) PA373 (x4) [252] →12/82 PA286 ☒ (x4)	☒ NJ254 27x43x9mm, NBR ☒ NJ072 35x50x8mm, NBR ☒ NJ073 74x98x12mm, MVQ	
	JC414 ☒ (x2) JA077 ☒ (x4) ⊕JE625	JN512 →Eng.2000000 JN583 Eng.2000000 →	JH171	PA288 ☒ (x4) PA286 ☒ (x4)	☒ NJ254 27x43x9mm, NBR ☒ NJ072 35x50x8mm, NBR ☒ NJ073 74x98x12mm, MVQ	
	JB765	JM261	JH445		☒ NA774 73x92.1x9.5mm, MVQ	JR147 [11]
	JA510	JM477	JH370		☒ NA774 73x92.1x9.5mm, MVQ	JR147 [11]
	JA502 ⊕JE331	JM261	JH445		☒ NA774 73x92.1x9.5mm, MVQ →12/70	JR147 [11]
	JA502 ⊕JE331	JM261	JH445		☒ NA774 73x92.1x9.5mm, MVQ	JR147 [11]
	JA502 ⊕JE331	JM261	JH445		☒ NA774 73x92.1x9.5mm, MVQ	JR147 [11]
	JA626 ☒ ☒ (x2) JA625 ☒ ☒ (x2) ⊕JE331 (x2)					
	JA502 ⊕JE331	JM261	JH445		☒ NA774 73x92.1x9.5mm, MVQ	JR147 [11]
		JM477	JH370		☒ NA774 73x92.1x9.5mm, MVQ	JR147 [11]
			HCO16 ☒		☒ NA298 44.5x50.7x14.3mm, NBR	
	JA510	JM477	JH370		☒ NA774 73x92.1x9.5mm, MVQ	JR147 [11]
	JA510 →12/74	JM477	JH370		☒ NA774 73x92.1x9.5mm, MVQ	JR147 [11]
	JA510	JM477	JH370		☒ NA774 73x92.1x9.5mm, MVQ	JR147 [11]

TRIUMPH









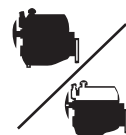

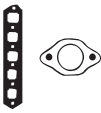

cc

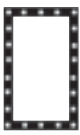

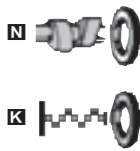





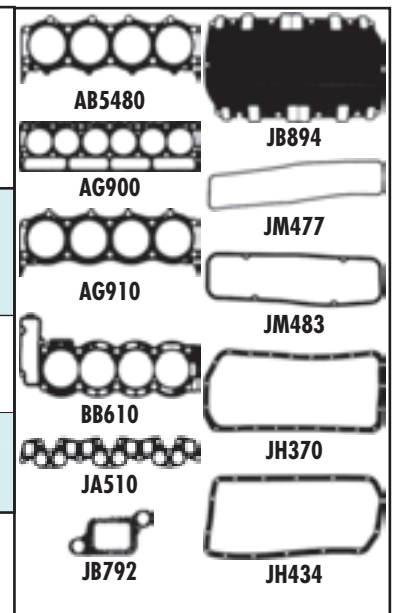

KW/PS











TR 7 Convertible 2.0L				05/79 → 12/81	17	BB610 (Fibre)		EB610 [12]
CG2	1998	4	90.30		77-78/ 105- 106			
TR 8 Convertible 3.5L				01/80 → 12/81	18	AB5480 (Fibre) (x2) [188]	CG913 [243]	EG914
	3532	8			99/135	AG910 (Steel) (x2)	CG915 [244]	
Vitesse 2.0L				12/68 → 12/71	19	AG900 (Fibre) [231]	CG902 []	EE350 [12]
Vitesse Cabriolet 2.0L				12/68 → 12/71				
	1998	6			77/105			

						
	JB894  JB792  (x8)	JM483 (x2) (31-029717-00)	JH434		<input checked="" type="checkbox"/> NB849 48.7x63.5x8mm, FPM (50-319467-00) <input checked="" type="checkbox"/> NB291  82.6x98.7x12.7mm, MVQ	
	JA510	JM477	JH370		<input checked="" type="checkbox"/> NA774  73x92.1x9.5mm, MVQ	NA162 [42] Rubber JR147 [11]



		CC			9			CC			9
10 S	Petrol	993	4	72.00	186	20 S	Petrol	1979	4	95.00	97
12 NC	Petrol	1196	4	79.00	187	20 SE	Petrol	1998	4	86.00	100
12 NV	Petrol	1196	4	77.80	189	20 SE	Petrol	1998	4	86.00	126
12 NV	Petrol	1196	4	77.80	199	20 SE	Petrol	1998	4	86.00	201
12 S	Petrol	1196	4	79.00	189	20 SEH	Petrol	1998	4	86.00	125
12 S	Petrol	1196	4	79.00	7	20 SEH	Petrol	1998	4	86.00	56
12 ST	Petrol	1196	4	77.80	190	20 SER	Petrol	1998	4	86.00	98
13 N	Petrol	1297	4	75.00	109	20 XE	Petrol	1998	4	86.00	57
13 NB	Petrol	1297	4	75.00	192	22 E	Petrol	2197	4	95.00	102
13 S	Petrol	1297	4	75.00	10	22 E	Petrol	2197	4	95.00	213
13 S	Petrol	1297	4	75.00	109	23 D	Diesel	2260	4	92.00	103
13 S	Petrol	1297	4	75.00	74	23 DTR	Diesel	2260	4	92.00	105
13 SB	Petrol	1297	4	75.00	193	23 DTR	Diesel	2260	4	92.00	162
14 NV	Petrol	1389	4	77.60	110	23 L	Petrol	2279	4	97.53	255
14 NV	Petrol	1389	4	77.60	14	23 TD	Diesel	2260	4	92.00	214
14 NV	Petrol	1389	4	77.60	18	23 YD	Diesel	2260	4	92.00	104
14 NV	Petrol	1389	4	77.60	194	23 YDT	Diesel	2260	4	92.00	105
15 D	Diesel	1488	4	76.00	150	25 DT	Diesel	2497	6	80.00	208
15 D	Diesel	1488	4	76.00	196	25 E	Petrol	2490	6	87.00	215
15 D	Diesel	1488	4	76.00	200	25TDS (VM41B)	Diesel	2499	4	92.00	164
15 DT	Diesel	1488	4	76.00	76	28 TDI (4JB1T)	Diesel	2771	4	93.00	165
15 DT (T4EC1)	Diesel	1488	4	76.00	150	4 JA1	Diesel	2499	4	93.00	87
15 DT (T4EC1)	Diesel	1488	4	76.00	19	4 JA1T	Diesel	2499	4	93.00	87
15 DT (T4EC1)	Diesel	1488	4	76.00	196	4 JG2TC	Diesel	3059	4	95.40	176
15 DT (T4EC1)	Diesel	1488	4	76.00	76	4 JX1	Diesel	2999	4	95.40	175
16 D	Diesel	1598	4	80.00	113	4 ZD1	Petrol	2255	4	89.50	85
16 D	Diesel	1598	4	80.00	25	4 ZD1	Petrol	2255	4	89.50	86
16 DA	Diesel	1598	4	80.00	113	4FD1	Diesel	2189	4	88.00	174
16 DA	Diesel	1598	4	80.00	26	4ZC1	Petrol	1995	4	88.00	173
16 DA	Diesel	1598	4	80.00	78	6 VD1	Petrol	3165	6	93.40	166
16 N	Petrol	1598	4	80.00	116	6 VD1	Petrol	3165	6	93.40	177
16 S	Petrol	1598	4	85.00	111	6 VE1	Petrol	3494	6	93.40	178
16 S	Petrol	1598	4	85.00	33	C 12 NZ	Petrol	1195	4	72.00	131
16 S	Petrol	1598	4	85.00	77	C 12 NZ	Petrol	1195	4	72.00	141
16 SH	Petrol	1598	4	80.00	111	C 12 NZ	Petrol	1195	4	72.00	188
16 SH	Petrol	1598	4	80.00	33	C 13 N	Petrol	1297	4	75.00	191
16 SH	Petrol	1598	4	80.00	77	C 14 NZ	Petrol	1389	4	77.60	133
16 SV	Petrol	1598	4	79.00	112	C 14 NZ	Petrol	1389	4	77.60	14
16 SV	Petrol	1598	4	79.00	23	C 14 NZ	Petrol	1389	4	77.60	145
16 SV	Petrol	1598	4	79.00	79	C 14 NZ	Petrol	1389	4	77.60	149
17 D	Diesel	1699	4	82.50	118	C 14 NZ	Petrol	1389	4	77.60	194
17 D	Diesel	1699	4	82.50	37	C 14 NZ	Petrol	1389	4	77.60	64
17 D	Diesel	1699	4	82.50	80	C 14 NZ	Petrol	1389	4	77.60	75
17 D (4EE1)	Diesel	1686	4	79.00	136	C 14 SE	Petrol	1389	4	77.60	134
17 D (4EE1)	Diesel	1686	4	79.00	154	C 14 SE	Petrol	1389	4	77.60	145
17 DR	Diesel	1699	4	82.50	117	C 14 SE	Petrol	1389	4	77.60	15
17 DR	Diesel	1699	4	82.50	38	C 14 SE	Petrol	1389	4	77.60	195
17 DR	Diesel	1699	4	82.50	70	C 16 LZ	Petrol	1598	4	80.00	114
17 DT (TC4EE1)	Diesel	1686	4	79.00	119	C 16 LZ	Petrol	1598	4	80.00	34
17 DT (TC4EE1)	Diesel	1686	4	79.00	41	C 16 NZ	Petrol	1598	4	79.00	114
18 E	Petrol	1796	4	84.80	122	C 16 NZ	Petrol	1598	4	79.00	29
18 E	Petrol	1796	4	84.80	43	C 16 NZ	Petrol	1598	4	79.00	31
18 E	Petrol	1796	4	84.80	44	C 16 NZ	Petrol	1598	4	79.00	34
18 E	Petrol	1796	4	84.80	46	C 16 NZ	Petrol	1598	4	79.00	65
18 E	Petrol	1796	4	84.80	82	C 16 SE	Petrol	1598	4	79.00	198
18 NV	Petrol	1796	4	84.80	93	C 16 SE	Petrol	1598	4	79.00	30
18 S	Petrol	1796	4	84.80	95	C 16 SEI	Petrol	1598	4	79.00	198
18 SE	Petrol	1796	4	84.80	121	C 16 XE	Petrol	1598	4	79.00	151
18 SE	Petrol	1796	4	84.80	122	C 18 NE	Petrol	1796	4	84.80	123
18 SE	Petrol	1796	4	84.80	124	C 18 NZ	Petrol	1796	4	84.80	120
18 SE	Petrol	1796	4	84.80	44	C 18 NZ	Petrol	1796	4	84.80	45
18 SE	Petrol	1796	4	84.80	81	C 18 XE	Petrol	1799	4	81.60	47
18 SE	Petrol	1796	4	84.80	82	C 18 XEL	Petrol	1799	4	81.60	48
18 SEH	Petrol	1796	4	84.80	94	C 20 LET	Petrol	1998	4	86.00	129
18 SV	Petrol	1796	4	84.80	120	C 20 LET	Petrol	1998	4	86.00	91
18 SV	Petrol	1796	4	84.80	96	C 20 NE	Petrol	1998	4	86.00	100
20 E	Petrol	1979	4	95.00	101	C 20 NE	Petrol	1998	4	86.00	125
20 NE	Petrol	1998	4	86.00	125	C 20 NE	Petrol	1998	4	86.00	158
20 NE	Petrol	1998	4	86.00	62	C 20 NE	Petrol	1998	4	86.00	56

		CC			9			CC			9
C 20 NE	Petrol	1998	4	86.00	58	X 17 D (4EE1)	Diesel	1686	4	79.00	136
C 20 NE	Petrol	1998	4	86.00	88	X 17 D (4EE1)	Diesel	1686	4	79.00	154
C 20 NEF	Petrol	1998	4	86.00	99	X 17 DT (TC4EE1)	Diesel	1686	4	79.00	236
C 20 NEJ	Petrol	1998	4	86.00	99	X 17 DTL	Diesel	1699	4	82.50	40
C 20 XE	Petrol	1998	4	86.00	128	X 17 DTL	Diesel	1699	4	82.50	71
C 20 XE	Petrol	1998	4	86.00	59	X 18 XE	Petrol	1799	4	81.60	238
C 20 XE	Petrol	1998	4	86.00	90	X 18 XE	Petrol	1799	4	81.60	48
C 24 NE	Petrol	2410	4	95.00	106	X 18 XE1	Petrol	1796	4	80.50	238
C 24 NE	Petrol	2410	4	95.00	163	X 18 XE1	Petrol	1796	4	80.50	261
C 25 XE	Petrol	2498	6	81.60	130	X 18 XE1	Petrol	1796	4	80.50	42
C 25 XE	Petrol	2498	6	81.60	92	X 20 DTH	Diesel	1995	4	84.00	204
C 26 NE	Petrol	2594	6	88.80	107	X 20 DTH	Diesel	1995	4	84.00	242
C 26 NE	Petrol	2594	6	88.80	216	X 20 DTH	Diesel	1995	4	84.00	55
C 30 SE	Petrol	2969	6	95.00	108	X 20 DTL	Diesel	1995	4	84.00	241
C 30 SE	Petrol	2969	6	95.00	217	X 20 DTL	Diesel	1995	4	84.00	266
C 30 SEJ	Petrol	2969	6	95.00	108	X 20 DTL	Diesel	1995	4	84.00	54
C223	Diesel	2238	4	88.00	83	X 20 DTL	Diesel	1995	4	84.00	72
C223	Diesel	2238	4	88.00	84	X 20 SE	Petrol	1998	4	86.00	158
E 12 GV	Petrol	1196	4	79.00	187	X 20 SE	Petrol	1998	4	86.00	202
E 16 NZ	Petrol	1598	4	79.00	114	X 20 XEV	Petrol	1998	4	86.00	127
E 16 NZ	Petrol	1598	4	79.00	31	X 20 XEV	Petrol	1998	4	86.00	203
E 16 NZ	Petrol	1598	4	79.00	34	X 20 XEV	Petrol	1998	4	86.00	244
E 16 SE	Petrol	1598	4	79.00	197	X 20 XEV	Petrol	1998	4	86.00	53
E 18 NV	Petrol	1796	4	84.80	120	X 20 XEV	Petrol	1998	4	86.00	89
E 18 NVR	Petrol	1796	4	84.80	93	X 22 DTH	Diesel	2172	4	84.00	159
F4R 720	Petrol	1998	4	82.70	253	X 22 DTH	Diesel	2172	4	84.00	225
F8Q 600	Diesel	1870	4	80.00	5	X 22 SE	Petrol	2198	4	86.00	160
F8Q 606	Diesel	1870	4	80.00	5	X 22 XE	Petrol	2198	4	86.00	161
F9Q 760	Diesel	1870	4	80.00	252	X 22 XE	Petrol	2198	4	86.00	226
F9Q 770	Diesel	1870	4	80.00	179	X 25 DT	Diesel	2497	6	80.00	208
F9Q 774	Diesel	1870	4	80.00	180	X 25 XE	Petrol	2498	6	81.60	209
G9T 720	Diesel	2188	4	87.00	181	X 25 XE	Petrol	2498	6	81.60	248
G9U 720	Diesel	2463	4	89.00	184	X 25 XE	Petrol	2498	6	81.60	92
G9U 724	Diesel	2463	4	89.00	184	X 30 XE	Petrol	2962	6	86.00	211
G9U 730	Diesel	2463	4	89.00	254	X 30 XE	Petrol	2962	6	86.00	227
G9U 750	Diesel	2463	4	89.00	184	Y 16 XE	Petrol	1598	4	79.00	235
G9U 754	Diesel	2463	4	89.00	182	Y 17 DT	Diesel	1686	4	79.00	137
G9U 754	Diesel	2463	4	89.00	184	Y 17 DT	Diesel	1686	4	79.00	155
G9U-720	Diesel	2463	4	89.00	184	Y 17 DT	Diesel	1686	4	79.00	39
S8U 758	Diesel	2499	4	93.00	6	Y 17 DTL	Diesel	1686	4	79.00	137
S8U 770	Diesel	2499	4	93.00	183	Y 17 DTL	Diesel	1686	4	79.00	155
S8U 780	Diesel	2499	4	93.00	6	Y 20 DTH	Diesel	1995	4	84.00	220
S8U 782	Diesel	2499	4	93.00	6	Y 20 DTH	Diesel	1995	4	84.00	242
S9W 702	Diesel	2799	4	94.40	185	Y 20 DTH	Diesel	1995	4	84.00	243
X 10 XE	Petrol	973	3	72.50	139	Y 20 DTH	Diesel	1995	4	84.00	266
X 12 SZ	Petrol	1195	4	72.00	131	Y 20 DTH	Diesel	1995	4	84.00	55
X 12 SZ	Petrol	1195	4	72.00	141	Y 20 DTH	Diesel	1995	4	84.00	73
X 12 XE	Petrol	1199	4	72.50	142	Y 20 DTL	Diesel	1995	4	84.00	54
X 12 XE	Petrol	1199	4	72.50	8	Y 22 DTH	Diesel	2172	4	84.00	159
X 14 SZ	Petrol	1389	4	77.60	145	Y 22 DTH	Diesel	2172	4	84.00	206
X 14 XE	Petrol	1389	4	77.60	13	Y 22 DTR	Diesel	2172	4	84.00	221
X 14 XE	Petrol	1389	4	77.60	147	Y 22 DTR	Diesel	2172	4	84.00	247
X 14 XE	Petrol	1389	4	77.60	16	Y 22 SE	Petrol	2198	4	86.00	160
X 14 XE	Petrol	1389	4	77.60	17	Y 22 XE	Petrol	2198	4	86.00	205
X 14 XE	Petrol	1389	4	77.60	230	Y 25 DT	Diesel	2497	6	80.00	207
X 15 DT (T4EC1)	Diesel	1488	4	76.00	150	Y 26 SE	Petrol	2597	6	83.20	210
X 16 SZ	Petrol	1598	4	79.00	115	Y 26 SE	Petrol	2597	6	83.20	249
X 16 SZ	Petrol	1598	4	79.00	28	Y 30 DT	Diesel	2958	6	87.50	223
X 16 SZ	Petrol	1598	4	79.00	66	Y 30 DT	Diesel	2958	6	87.50	250
X 16 SZR	Petrol	1598	4	79.00	20	Y 32 NE	Petrol	3165	6	93.40	166
X 16 SZR	Petrol	1598	4	79.00	234	Y 32 SE	Petrol	3175	6	87.50	212
X 16 SZR	Petrol	1598	4	79.00	29	Z 10 XE	Petrol	973	3	72.50	1
X 16 SZR	Petrol	1598	4	79.00	67	Z 10 XEP	Petrol	998	3	73.40	138
X 16 XE	Petrol	1598	4	79.00	152	Z 10 XEP	Petrol	998	3	73.40	2
X 16 XE	Petrol	1598	4	79.00	231	Z 12 XE	Petrol	1199	4	72.50	140
X 16 XEL	Petrol	1598	4	79.00	235	Z 12 XE	Petrol	1199	4	72.50	3
X 16 XEL	Petrol	1598	4	79.00	24	Z 12 XE	Petrol	1199	4	72.50	9
X 16 XEL	Petrol	1598	4	79.00	260	Z 12 XE	Bi-Fuel	1199	4	72.50	140
X 16 XEL	Petrol	1598	4	79.00	32	Z 12 XEP	Petrol	1229	4	73.40	143



CC



9



CC



9











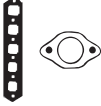

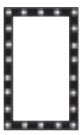

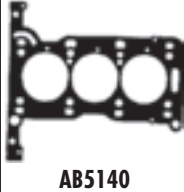
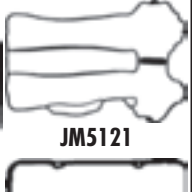
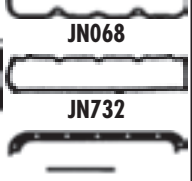
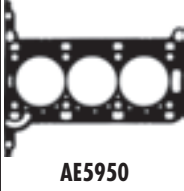
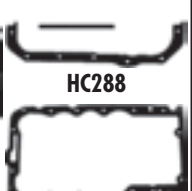
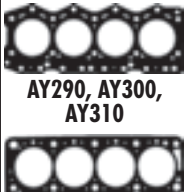
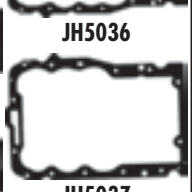
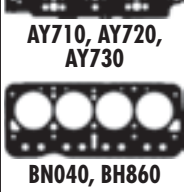
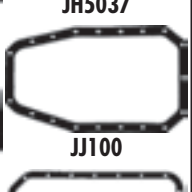

Z 12 XEP	Petrol	1229	4	73.40	4
Z 13 DT	Diesel	1248	4	69.80	144
Z 13 DT	Diesel	1248	4	69.80	228
Z 13 DTH	Diesel	1248	4	69.60	11
Z 14 XE	Petrol	1389	4	77.60	13
Z 14 XE	Petrol	1389	4	77.60	146
Z 14 XE	Petrol	1389	4	77.60	258
Z 14 XEP	Petrol	1364	4	73.40	12
Z 14 XEP	Petrol	1364	4	73.40	132
Z 14 XEP	Petrol	1364	4	73.40	148
Z 14 XEP	Petrol	1364	4	73.40	157
Z 14 XEP	Petrol	1364	4	73.40	167
Z 14 XEP	Petrol	1364	4	73.40	229
Z 16 SE	Petrol	1598	4	79.00	135
Z 16 SE	Petrol	1598	4	79.00	169
Z 16 SE	Petrol	1598	4	79.00	21
Z 16 SE	Petrol	1598	4	79.00	68
Z 16 XE	Petrol	1598	4	79.00	170
Z 16 XE	Petrol	1598	4	79.00	235
Z 16 XE	Petrol	1598	4	79.00	24
Z 16 XE	Petrol	1598	4	79.00	27
Z 16 XE	Bi-Fuel	1598	4	79.00	27
Z 16 XEP	Petrol	1598	4	79.00	168
Z 16 XEP	Petrol	1598	4	79.00	22
Z 16 XEP	Petrol	1598	4	79.00	233
Z 16 XEP	Petrol	1598	4	79.00	259
Z 17 DTH	Diesel	1686	4	79.00	153
Z 17 DTH	Diesel	1686	4	79.00	171
Z 17 DTH	Diesel	1686	4	79.00	36
Z 17 DTL	Diesel	1686	4	79.00	35
Z 17 DTL	Diesel	1686	4	79.00	69
Z 18 XE	Petrol	1799	4	80.50	156
Z 18 XE	Petrol	1799	4	80.50	172
Z 18 XE	Petrol	1799	4	80.50	232
Z 18 XE	Petrol	1799	4	80.50	237
Z 18 XE	Petrol	1799	4	80.50	261
Z 18 XE	Petrol	1799	4	80.50	42
Z 18 XE	Bi-Fuel	1799	4	80.50	237
Z 18 XE	Bi-Fuel	1799	4	80.50	42
Z 19 DT	Diesel	1910	4	82.00	218
Z 19 DT	Diesel	1910	4	82.00	239
Z 19 DT	Diesel	1910	4	82.00	262
Z 19 DT	Diesel	1910	4	82.00	50
Z 19 DTH	Diesel	1910	4	82.00	219
Z 19 DTH	Diesel	1910	4	82.00	240
Z 19 DTH	Diesel	1910	4	82.00	263
Z 19 DTH	Diesel	1910	4	82.00	49
Z 19 DTJ	Diesel	1910	4	82.00	49
Z 20 LEH	Petrol	1998	4	86.00	265
Z 20 LEH	Petrol	1998	4	86.00	52
Z 20 LEL	Petrol	1998	4	86.00	51
Z 20 LEL	Petrol	1998	4	86.00	61
Z 20 LER	Petrol	1998	4	86.00	264
Z 20 LER	Petrol	1998	4	86.00	51
Z 20 LET	Petrol	1998	4	86.00	256
Z 20 LET	Petrol	1998	4	86.00	267
Z 20 LET	Petrol	1998	4	86.00	60
Z 22 SE	Petrol	2198	4	86.00	245
Z 22 SE	Petrol	2198	4	86.00	257
Z 22 SE	Petrol	2198	4	86.00	269
Z 22 SE	Petrol	2198	4	86.00	63
Z 22 XE	Petrol	2198	4	86.00	205
Z 22 YH	Petrol	2198	4	86.00	222
Z 22 YH	Petrol	2198	4	86.00	246
Z 22 YH	Petrol	2198	4	86.00	268
Z 30 DT	Diesel	2958	6	87.50	223
Z 30 DT	Diesel	2958	6	87.50	250
Z 32 SE	Petrol	3175	6	88.50	224
Z 32 SE	Petrol	3175	6	88.50	251

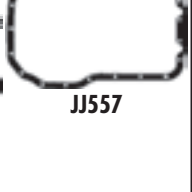
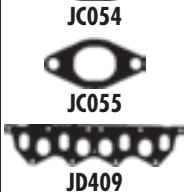

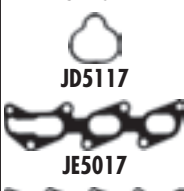
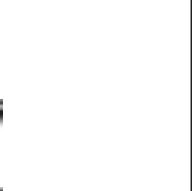
KW/PS

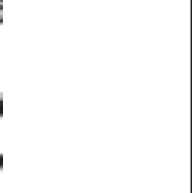
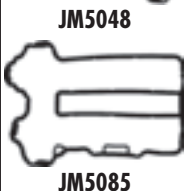

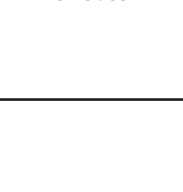
Agila 1.0L 12V						09/00 →	1	AB5140 (MLS) (30-028029-00)		CB5141 ■ [8] (21-28029-21/0)	EB5140 (22-29175-00/0)
Z 10 XE	973	3	72.50	Injection, DOHC	43/58						
Agila 1.0L 12V						08/03 →	2	AE5950 (Steel) (30-029101-00)		CE5950 (21-29101-00/0)	
Z 10 XEP	998	3	73.40	Injection, DOHC	44/60						
Agila 1.2L 16V						09/00 →	3	AB5240 (MLS) (30-028390-20) → Ch.3G999999 AH5030 (MLS) (30-030366-00) Ch.4G000001 →		CB5240 ■ [8] (21-28390-21/0) → Ch.3G999999 CH5030 (21-30366-00/0) Ch.4G000001 →	EB5240 (22-29169-00/0)
Z 12 XE	1199	4	72.50	Injection, DOHC	55/75						
Agila 1.2L 16V Twinport						07/04 →	4	AH5030 (MLS) (30-030366-00)		CH5031 (21-30366-01/0)	
Z 12 XEP	1229	4	73.40	Injection, DOHC	59/80						
Arena 1.9L D Diesel						03/98 → 08/01	5	AY710 (Steel Elastomer), 1.36mm, 2 Holes (30-029016-00) → 0.073mm AY720 (Steel Elastomer), 1.44mm, 1 Hole (30-029017-00) → 0.073 → 0.206mm AY730 (Steel Elastomer), 1.52mm, 3 Holes (30-029018-00) → 0.206mm →		DL961 ▲ (21-26632-21/0)	EL960 [8] (22-27574-00/0)
F8Q 600/F8Q 606	1870	4	80.00		44/60						
Arena 2.5L D Diesel						03/98 → 08/01	6	AY290 (Fibre), 1.60mm [112] (30-027426-00) AY300 (Fibre), 1.70mm [112] (30-026654-20) AY310 (Fibre), 1.80mm [112] (30-026655-20)		DE588 ▲ [109] (21-26037-23/0)	FY291 ▲ [12] (20-27426-00/0)
S8U 780/S8U 782 S8U 758	2499 2499	4 4	93.00 93.00		55/75 55-58/ 75-79						
Astra 1.2L						09/84 → 08/91	7	BN040 (Fibre), 1.36mm (30-022712-20) BH860 (Fibre), 1.70mm (30-023271-20)		DH860 ■ [233] (21-23271-21/0) DN041 ■ [234] (21-22712-26/0) DN042 (21-22712-27/0)	ET820 (22-20159-02/0)
Astra 1.2L S						02/82 → 08/84					
12 S	1196	4	79.00	OHV	44/60						
Astra 1.2L 16V						02/98 → 09/00	8	AB5240 (MLS) (30-028390-20)		CB5241 ■ (21-28390-20/0)	EB5240 (22-29169-00/0)
X 12 XE	1199	4	72.50	Injection, DOHC	48/65						
Astra 1.2L 16V						09/00 →	9	AB5240 (MLS) (30-028390-20) → Ch.3G999999 AH5030 (MLS) (30-030366-00) Ch.4G000001 →		CB5240 ■ [8] (21-28390-21/0) → Ch.3G999999 CH5030 (21-30366-00/0) Ch.4G000001 →	EB5240 (22-29169-00/0)
Z 12 XE	1199	4	72.50	Injection, DOHC	55/75						











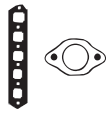

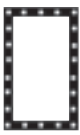

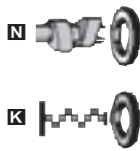















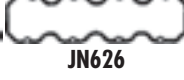























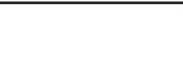



















































								
HBS253 Ⓢ (22-29015B) M8x1.25x119mm (x10)	JD5117 ■ (x3) (50-029186-00) JE5017 ■ (31-029177-00)	JM5085 (50-029176-00) →Eng.1G001110 JM5121 (50-029185-00) Eng.1G001111→	JH5037 (31-029175-00)	PA5025 (x12) (50-319386-00) HR5096 ■ (24-31938-61/0)	NA5108 ■ 42x55x7mm, FPM (50-319392-00) NB698 ■ 80x98x10mm, FPM (50-319273-00)	JR5030 [11]		 AB5140  JN068  JN732  AB5240  HC288
HBS253 Ⓢ (22-29015B) M8x1.25x119mm (x10)	JD5904 ■ (x4) (50-030368-00) (FPM) JE5017 ■ (31-029177-00)	JM5121 (50-029185-00)	JH5037 (31-029175-00)	PA5025 (x12) (50-319386-00) HR5096 ■ (24-31938-61/0)	NA5108 ■ 42x55x7mm, FPM (50-319392-00) NB698 ■ 80x98x10mm, FPM (50-319273-00)	JR5030 [11]		 AE5950  JH5036  AY290, AY300, AY310  JH5037
HBS252 Ⓢ (22-29014B) M8x1.25x119mm (x12)	JD5117 ■ (x4) (50-029186-00) →Ch.3G999999 JD5904 ■ (x4) (50-030368-00) (FPM) Ch.4G000001→ JE5024 ■ (31-029170-00)	JM5048 (50-029167-00) →Ch.1G001502 JM5071 (50-029232-00) Ch.1G001503→	JH5036 (31-029169-00)	HR5048 ■ (24-31938-60/0)	NA5108 ■ 42x55x7mm, FPM (50-319392-00) NB698 ■ 80x98x10mm, FPM (50-319273-00)	JR5030 [11]		 AY710, AY720, AY730  JJ100
HBS252 Ⓢ (22-29014B) M8x1.25x119mm (x12)	JD5904 ■ (x4) (50-030368-00) (FPM)	JM5071 (50-029232-00)	JH5036 (31-029169-00)	HR5048 ■ (24-31938-60/0)	NA5108 ■ 42x55x7mm, FPM (50-319392-00) NB698 ■ 80x98x10mm, FPM (50-319273-00)	JR5030 [11]		 BN040, BH860  JA415
HBS244 Ⓢ (22-51103B) M12x1.50x111mm (x10)	JD409 (31-026628-10)	JN732 (50-026632-00)	JJ557 → PA349 (33-102290-10) 22x16x2mm	HR569 ■ 24-30667-00/0	NF846 25x42x7mm, FPM/ACM (50-319516-00) NF843 ■ 50x68x10mm, FPM/ACM (50-305667-70) NF850 ■ 85x105x8mm, FPM (50-319183-00)			 JA499  JC054  JC055  JD409
HBS011 Ⓢ (22-51004B) M12x1.25x160mm (x10) M12x1.25x119mm (x12)	JC054 ■ (x4) (31-024274-10) JC055 ■ (x4) (31-025031-10)		JJ100					 JD5117  JE5017  JE5024
HBS112 Ⓢ (22-29006B) M9x1.25x80mm (x5) M9x1.25x100mm (x5)	JA499 ■ JA415 ■ (31-020165-10)	JN068 (31-023120-10)	HC288 ■ (23-20161-01/0)	HR291 ■ (50-024209-00)	NB691 ■ 54x82x9mm, ACM	NB575 [2]■		 JM5048  JM5085
HBS252 Ⓢ (22-29014B) M8x1.25x119mm (x12)	JE5024 ■ (31-029170-00)	JM5048 (50-029167-00)	JH5036 (31-029169-00)	HR5048 ■ (24-31938-60/0)	NA5108 ■ 42x55x7mm, FPM (50-319392-00) NB698 ■ 80x98x10mm, FPM (50-319273-00)	JR5030 [11]		
HBS252 Ⓢ (22-29014B) M8x1.25x119mm (x12)	JD5117 ■ (x4) (50-029186-00) →Ch.3G999999 JD5904 ■ (x4) (50-030368-00) (FPM) Ch.4G000001→ JE5024 ■ (31-029170-00)	JM5048 (50-029167-00) →Ch.1G001502 JM5071 (50-029232-00) Ch.1G001503→	JH5036 (31-029169-00)	HR5048 ■ (24-31938-60/0)	NA5108 ■ 42x55x7mm, FPM (50-319392-00) NB698 ■ 80x98x10mm, FPM (50-319273-00)	JR5030 [11]		



KW/PS



Astra 1.3L		09/84 → 08/91		10		BK470 (Fibre) (30-024033-10)		DK470 (21-24033-26/0) →12/85 DK471 (21-24033-30/0) 01/86 →		EK470 (22-27194-05/0)	
13 S	1297	4	75.00	Carburettor, SOHC	42-55/ 57-75						
Astra 1.3L CDTI Diesel		08/05 →		11		AD5800 (MLS), 0.72mm (30-029762-00) AD5810 (MLS), 0.82mm, 1 Hole (30-029763-00) AD5820 (MLS), 0.92mm, 2 Holes (30-029764-00)					
Z 13 DTH	1248	4	69.60	Direct Injection	66-74/ 90-101						
Astra 1.4L		03/04 →		12		AH5030 (MLS) (30-030366-00)		CH5030 (21-30366-00/0)			
Z 14 XEP	1364	4	73.40	Injection, DOHC	66/89						
Astra 1.4L 16V		02/98 →		13		AB5360 (MLS) (30-029200-00) Z14XE AY210 (Fibre) (30-027985-00) X14XE		CB5360 (21-29200-20/0) Z14XE CY211 (21-27985-22/0) X14XE		EB5360 (22-27665-02/0) →Eng.02M25253 →Eng.20U75999 Z14XE EY230 (22-27665-01/0) X14XE EB5541 [8] (22-27665-03/0) Eng.02M25254 → Eng.20U76000 → Z14XE	
X 14 XE/Z 14 XE	1389	4	77.60	Injection, DOHC	66/89						
Astra 1.4L i		01/90 → 09/98		14		BS260 (Fibre) (30-026329-10)		DS260 (21-26329-21/0)		EK470 (22-27194-05/0)	
Astra 1.4L S		01/90 → 02/98									
C 14 NZ	1389	4	77.60	SPi, SOHC	44/60						
14 NV	1389	4	77.60	Carburettor, SOHC	53-55/ 72-75						
Astra 1.4L i		03/91 → 09/98		15		BS260 (Fibre) (30-026329-10)		DS261 (21-26329-22/0)		ES260 [248] (22-27194-00/0)	
Astra Convertible 1.4L i		05/93 → 03/01									
C 14 SE	1389	4	77.60	Injection, SOHC	60/81						
Astra 1.4L i 16V		02/96 → 09/98		16		AY210 (Fibre) (30-027985-00)		CY210 (21-27985-21/0) →01/98 CY211 (21-27985-22/0) 02/98 →		EY230 (22-27665-01/0)	
Astra Convertible 1.4L i 16V		01/96 → 03/01									
X 14 XE	1389	4	77.60	Injection, DOHC	66/89						











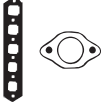

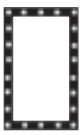

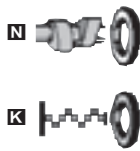

















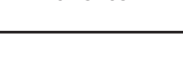



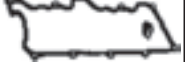

















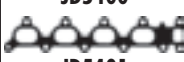

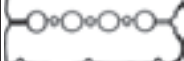

















































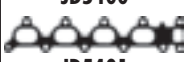

















								
HBS002  (22-29098B) M10x1.25x140mm (x10)	JC280  (31-024313-10) JC281  (31-024312-10)  JE119 (31-024520-00)	JN344 (31-024299-00) →12/85 JN626 (31-026099-10) 01/86→	JH5005 [116] (31-027194-00) JJ120	PA565 (x8) (50-305900-50) HR342  (24-30590-05/0)	 NC006  35x48x7mm, MVQ (50-319161-00)  NB697  26x42x8mm, FPM (50-306704-00)  NB698  80x98x10mm, FPM (50-319273-00)	NB575 [2] 	 AB5360  JN344  AD5800  JN626  AD5810  JN929  AD5810  JP008  AD5820  JP009  AY210  JH5005  BK470  JH5036  BS260  JJ120  JC280  JJ575  JC281  JC823  JC824  JD444  JD445  JD5147  JD5148  JD5149  JD5269  JE119  JE5024  JM5059	
HBS353  (22-17025B) M10x1.25x119mm (x10)		JM5259 (31-030023-00)			 NA5230  78x100x9mm, PTFE (50-319522-00)			
HBS252  (22-29014B) M8x1.25x119mm (x12)	JD5904  (x4) (50-030368-00) (FPM) JE5024  (31-029170-00)	JM5071 (50-029232-00)	JH5036 (31-029169-00)	HR5048  (24-31938-60/0)	 NA5108  42x55x7mm, FPM (50-319392-00)  NB698  80x98x10mm, FPM (50-319273-00)	JR5030 [11]		
HBS055  (22-29012B) M10x1.25x153mm (x10)	JD5147  (31-029203-00) JD5149   (31-029207-00) Z14XE JD444  (31-027878-00) X14XE JD5148  (31-029204-00) Z14XE	JM5059 (50-029202-00) Z14XE	JJ575 [148] (50-027665-00)	HR791  24-30614-76/0	 NC006  (x2) 35x48x7mm, MVQ (50-319161-00)  NB697  26x42x8mm, FPM (50-306704-00)  NB698  80x98x10mm, FPM (50-319273-00)			
HBS002  (22-29098B) M10x1.25x140mm (x10)	JC824  (31-026334-00) JC281  (31-024312-10)	JN626 (31-026099-10)	JH5005 [116] (31-027194-00) JJ120	PA565 (x8) (50-305900-50) HR342  (24-30590-05/0)	 NC006  35x48x7mm, MVQ (50-319161-00)  NB697  26x42x8mm, FPM (50-306704-00)  NB698  80x98x10mm, FPM (50-319273-00)	NB575 [2] 		
HBS002  (22-29098B) M10x1.25x140mm (x10)	JC823  (31-027191-10) JC281  (31-024312-10)	JN929 (50-027192-10)	JH5005 [116] (31-027194-00) JJ120	PA565 (x8) (50-305900-50) HR342  (24-30590-05/0)	 NC006  35x48x7mm, MVQ (50-319161-00)  NB697  26x42x8mm, FPM (50-306704-00)  NB698  80x98x10mm, FPM (50-319273-00)			
HBS055  (22-29012B) M10x1.25x153mm (x10)	JD5269  (31-027984-00) →01/98 JD445   (31-027881-00) →01/98 JD5147  (31-029203-00) 02/98→ JD5149  (31-029207-00) 02/98→ JD444  (31-027878-00)	JP009  (50-027983-00) →01/98 JP008  (50-027982-00) →01/98 JM5059 (50-029202-00) 02/98→	JJ575 [148] (50-027665-00)	HR791  24-30614-76/0	 NC006  (x2) 35x48x7mm, MVQ (50-319161-00)  NB697  26x42x8mm, FPM (50-306704-00)  NB698  80x98x10mm, FPM (50-319273-00)			

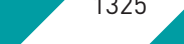

KW/PS



Astra 1.4L i 16V		02/96 → 02/98			17	AY210 (Fibre) (30-027985-00)	CY210 (21-27985-21/0)	EY230 (22-27665-01/0)
X 14 XE	1389	4	77.60	Injection, DOHC	66/89			
Astra 1.4L S		01/89 → 08/91			18	BS260 (Fibre) (30-026329-10)	DS260 (21-26329-21/0)	EK470 (22-27194-05/0)
14 NV	1389	4	77.60	Carburettor, SOHC	53-55/ 72-75			
Astra 1.5L DT Diesel		01/88 → 08/91			19	AY840 (MLS), 1.40mm (30-028998-00) → Eng.975024 AY850 (MLS), 1.45mm, 1 Hole (30-028999-00) → Eng.975024 AY860 (MLS), 1.50mm, 2 Holes (30-029000-00) → Eng.975024 AY900 (MLS), 1.40mm (30-029007-00) Eng.975025 → AY910 (MLS), 1.45mm, 1 Hole (30-029006-00) Eng.975025 → AY920 (MLS), 1.50mm, 2 Holes (30-029008-00) Eng.975025 →	CY811 ▲ ■ (21-27776-22/0)	FY811 ▲ (20-27776-02/0)
15 DT (T4EC1)	1488	4	76.00	SOHC	49-53/ 67-72			
Astra 1.6L		02/98 → 09/00			20	BP800 (Fibre) (30-025706-20)	DP806 (21-25706-30/0)	ES260 [211] (22-27194-00/0) EY230 [210] (22-27665-01/0)
Astra Convertible 1.6L i		01/96 → 03/01						
X 16 SZR	1598	4	79.00	SPi, SOHC	55/75			
Astra 1.6L		09/00 →			21	AE5920 (Steel) (30-029996-00)	CE5920 (21-29996-20/0)	EB5541 [8] (22-27665-03/0) ES260 [248] (22-27194-00/0)
Z 16 SE	1598	4	79.00	Injection, SOHC	62-64/ 84-87			
Astra 1.6L		03/04 →			22	AE5930 (MLS) (30-029999-00)	CE5930 (21-29999-20/0)	
Z 16 XEP	1598	4	79.00	Injection, DOHC	74-77/ 101- 105			
Astra 1.6L		09/84 → 08/91			23	BP800 (Fibre) (30-025706-20)	DP800 (21-25706-26/0)	EK484 [129] (22-27194-01/0)
Astra Convertible 1.6L i		01/87 → 12/91						
16 SV	1598	4	79.00	Carburettor, SOHC	60/82			

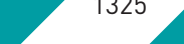









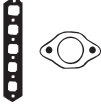

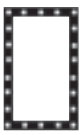

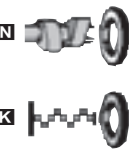

















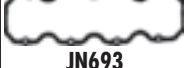















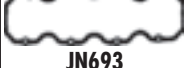















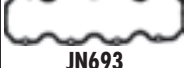



















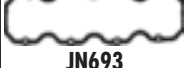





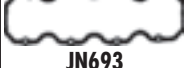





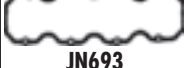



									
HBS055 ® (22-29012B) M10x1.25x153mm (x10)	JD5269 ■ (31-027984-00) JD445 ■□ (31-027881-00) JD444 ■ (31-027878-00)	JP009 ■ (50-027983-00) JP008 ■ (50-027982-00)	JJ575 [148] (50-027665-00)	HR791 ■ 24-30614-76/0	NC006 ■ (x2) 35x48x7mm, MVQ (50-319161-00) NB697 ■ 26x42x8mm, FPM (50-306704-00) NB698 ■ 80x98x10mm, FPM (50-319273-00)			 AE5920  AE5930  AY210  AY840, AY850, AY860  AY900, AY910, AY920  BP800  BS260  JC281  JC824  JD303  JD304  JD444  JD445  JD5269  JD5398  JD5399  JD5400  JD5401  JE120  JM5235	 JN626  JN777  JN929  JP008  JP009  JH5005  JH5058  JJ120  JJ575
HBS002 ® (22-29098B) M10x1.25x140mm (x10)	JC824 ■ (31-026334-00) JC281 ■ (31-024312-10)	JN626 (31-026099-10)	JH5005 [116] (31-027194-00) JJ120	PA565 (x8) (50-305900-50) HR342 ■ (24-30590-05/0)	NC006 ■ 35x48x7mm, MVQ (50-319161-00) NB697 ■ 26x42x8mm, FPM (50-306704-00) NB698 ■ 80x98x10mm, FPM (50-319273-00)	NB575 [2]■		 AY840, AY850, AY860  AY900, AY910, AY920  BP800  BS260  JC281  JC824  JD303  JD304  JD444  JD445  JD5269  JD5398  JD5399  JD5400  JD5401  JE120  JM5235	 JN626  JP008  JP009  JH5005  JH5058  JJ120  JJ575
HBS036 ® (22-29001B) M12x1.5x102mm (x10)	JD303 ■ JD5914 ■ (31-027778-00) JD304 ■  JE5029 (31-027779-00)	JN777 (50-027776-00)	JH5058 (31-027781-00)	PA658 (x8) (50-319265-00)	NJ449 ■ 40x52x6mm, NBR (50-319266-00) NJ449 ■ 40x52x6mm, NBR (50-319266-00) NK103 ■ 87x100x8.5mm, FPM			 JC281  JC824  JD303  JD304  JD444  JD445  JD5269  JD5398  JD5399  JD5400  JD5401  JE120  JM5235	 JN626  JP008  JP009  JH5005  JH5058  JJ120  JJ575
HBS002 ® (22-29098B) M10x1.25x140mm (x10)	JC824 ■ (31-026334-00) JC281 ■ (31-024312-10)	JN929 (50-027192-10)	JH5005 [211] (31-027194-00) JJ575 [210] (50-027665-00)	HR342 ■ (24-30590-05/0)	NC006 ■ 35x48x7mm, MVQ (50-319161-00) NB697 ■ 26x42x8mm, FPM (50-306704-00) NB698 ■ 80x98x10mm, FPM (50-319273-00)			 JD444  JD445  JD5269  JD5398  JD5399  JD5400  JD5401  JE120  JM5235	 JN626  JP008  JP009  JH5005  JH5058  JJ120  JJ575
HBS002 ® (22-29098B) M10x1.25x140mm (x10)	JD5398 ■ (31-029997-00) JD5399 ■ (31-029998-00)	JN929 (50-027192-10)		PA565 (x8) (50-305900-50) HR342 ■ (24-30590-05/0)	NC006 ■ 35x48x7mm, MVQ (50-319161-00) NB697 ■ 26x42x8mm, FPM (50-306704-00) NB698 ■ 80x98x10mm, FPM (50-319273-00)			 JD444  JD445  JD5269  JD5398  JD5399  JD5400  JD5401  JE120  JM5235	 JN626  JP008  JP009  JH5005  JH5058  JJ120  JJ575
HBS055 ® (22-29012B) M10x1.25x153mm (x10)	JD5400 ■ (31-030002-00) 01/04→ JD5401 ■ (31-030004-00) 01/04→	JM5235 (50-029985-00)		HR5087 ■ (24-31951-90/0)	NC006 ■ (x2) 35x48x7mm, MVQ (50-319161-00) NA5174 ■ 31.5x42x7mm, FPM (50-319469-00) NB698 ■ 80x98x10mm, FPM (50-319273-00)			 JE120  JM5235	 JN626  JP008  JP009  JH5005  JH5058  JJ120
HBS002 ® (22-29098B) M10x1.25x140mm (x10)	JC824 ■ (31-026334-00) JC281 ■ (31-024312-10)  JE120 (31-024767-00)	JN626 (31-026099-10)	JH5005 (x2) [116] (31-027194-00) JJ120 (x2)	PA565 (x8) (50-305900-50) HR342 ■ (24-30590-05/0)	NC006 ■ 35x48x7mm, MVQ (50-319161-00) NB697 ■ 26x42x8mm, FPM (50-306704-00) NB698 ■ 80x98x10mm, FPM (50-319273-00)	NB575 [2]■		 JE120  JM5235	 JN626  JP008  JP009  JH5005  JH5058

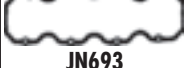

KW/PS

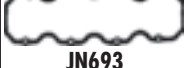

Astra 1.6L 16V						02/98 →	24	AB5540 (MLS) (30-029209-00)	CB5540 (21-29209-20/0)	EY230 (22-27665-01/0)
Z 16 XE	1598	4	79.00	Injection, DOHC	63-74/ 85-101		Z16XE	Z16XE	→Eng.02MB4997	→Eng.20R22448
X 16 XEL	1598	4	79.00	Injection, DOHC	74/100		AY220 (Fibre) X16XEL	DY232 (21-27986-25/0)	X16XEL	EB5541 [8] (22-27665-03/0)
Astra 1.6L D Diesel						02/82 →08/86	25	BLO10 (Fibre), 1.40mm (30-025124-10)	DLO10▲ (25-24572-02/0)	EK481 (22-25011-00/0)
16 D	1598	4	80.00	Indirect Injection, SOHC	40/54		→0.75mm	BLO20 (Fibre), 1.50mm, 1 Notch (30-025125-10)		
							→0.75 →0.85mm	BLO30 (Fibre), 1.60mm, 2 Notches (30-025126-10)		
							→0.85mm →			
Astra 1.6L D Diesel						09/84 →12/89	26	BLO10 (Fibre), 1.40mm (30-025124-10)	DLO10▲ (25-24572-02/0)	EK481 (22-25011-00/0)
16 DA	1598	4	80.00	Direct Injection, SOHC	40/54		→0.75mm	BLO20 (Fibre), 1.50mm, 1 Notch (30-025125-10)	→12/85	→12/85
							→0.75 →0.85mm	BLO30 (Fibre), 1.60mm, 2 Notches (30-025126-10)	DLO11▲ (21-26198-20/0)	EK485 (22-25011-04/0)
							→0.85mm →		01/86 →	01/86 →
Astra 1.6L Dualfuel						09/02 →	27	AB5540 (MLS) (30-029209-00)	CB5540 (21-29209-20/0)	EB5541 [8] (22-27665-03/0)
Astra Convertible 1.6L 16V						03/01 →				
Z 16 XE	1598	4	79.00	Injection, DOHC	63-74/ 85-101					
Astra 1.6L i						07/94 →02/98	28	BP800 (Fibre) (30-025706-20)	DP802 (21-25706-25/0)	ES260 [248] (22-27194-00/0)
Astra Convertible 1.6L i						03/93 →08/96				
X 16 SZ	1598	4	79.00	SPi, SOHC	52/71					
Astra 1.6L i						03/92 →09/98	29	BP800 (Fibre) (30-025706-20)	DP802 (21-25706-25/0)	EK484 [129] (22-27194-01/0)
C 16 NZ/X 16 SZR	1598	4	79.00	SPi, SOHC	55/75					ES260 [248] (22-27194-00/0)
Astra 1.6L i						03/92 →02/98	30	BP800 (Fibre) (30-025706-20)	DP803	ES260 [248] (22-27194-00/0)
Astra 1.6L Si						03/91 →12/94				
C 16 SE	1598	4	79.00	Injection, SOHC	74/100					
Astra 1.6L i						09/91 →02/98	31	BP800 (Fibre) (30-025706-20)	DP802 (21-25706-25/0)	EK484 [129] (22-27194-01/0)
C 16 NZ/E 16 NZ	1598	4	79.00	SPi, SOHC	55/75					

								
HBS055 Ⓢ (22-29012B) M10x1.25x153mm (x10)	JD5147 ■ (31-029203-00) JD444 ■ (31-027878-00) X16XEL JD5148 ■ (31-029204-00) Z16XE	JM5059 (50-029202-00)	JJ575 [148] (50-027665-00) → Eng.02MB4997 → Eng.20R22448	HR791 ■ 24-30614-76/0	NC006 ■ (x2) 35x48x7mm, MVQ (50-319161-00) NB697 ■ 26x42x8mm, FPM (50-306704-00) NB698 ■ 80x98x10mm, FPM (50-319273-00)			 AB5540  AY220  BLO10, BLO20, BLO30  BP800  JC281  JC436  JC437  JC823  JC824  JD444  JD5147  JD5148  JE119  JE120  JM5059  JN453  JN626  JN693  JN929  JH5005
HBS074 Ⓢ (22-29100B) M11x1.25x154mm (x10)	JC436 ■ (31-028012-00) JC437 ■ (31-024854-10) JE119 Ⓢ (31-024520-00)	JN453 [127] (31-024572-00)	JJ200 (31-025011-00)	HR343 ■ (24-30602-50/0)	NC006 ■ 35x48x7mm, MVQ (50-319161-00) NB734 ■ 35x50x8mm, FPM NB701 ■ 86x104x11mm, FPM (50-306261-50)	NB575 [2]■		 JC281  JC436  JC437  JC823  JC824  JD444  JD5147  JD5148  JE119  JE120  JM5059  JN453  JN626  JN693  JN929  JH5005
HBS074 Ⓢ (22-29100B) M11x1.25x154mm (x10)	JC436 ■ (31-028012-00) JC437 ■ (31-024854-10) JE119 Ⓢ (31-024520-00)	JN453 [127] (31-024572-00) →12/85 JN693 [128] (31-026198-10) 01/86→	JJ200 (31-025011-00)	HR343 ■ (24-30602-50/0)	NC006 ■ 35x48x7mm, MVQ (50-319161-00) NB734 ■ 35x50x8mm, FPM NB701 ■ 86x104x11mm, FPM (50-306261-50) →12/85 NB806 ■ 90x104x11mm, FPM (50-306552-00) 01/86→	NB575 [2]■		 JC281  JC436  JC437  JC823  JC824  JD444  JD5147  JD5148  JE119  JE120  JM5059  JN453  JN626  JN693  JN929  JH5005
HBS055 Ⓢ (22-29012B) M10x1.25x153mm (x10)	JD5147 ■ (31-029203-00) JD5148 ■ (31-029204-00)	JM5059 (50-029202-00)		HR791 ■ 24-30614-76/0	NC006 ■ (x2) 35x48x7mm, MVQ (50-319161-00) NB697 ■ 26x42x8mm, FPM (50-306704-00) NB698 ■ 80x98x10mm, FPM (50-319273-00)			 AB5540  AY220  BLO10, BLO20, BLO30  BP800  JC281  JC436  JC437  JC823  JC824  JD444  JD5147  JD5148  JE119  JE120  JM5059  JN453  JN626  JN693  JN929  JH5005
HBS002 Ⓢ (22-29098B) M10x1.25x140mm (x10)	JC824 ■ (31-026334-00) JC281 ■ (31-024312-10)	JN626 (31-026099-10)	JH5005 [116] (31-027194-00)	HR342 ■ (24-30590-05/0)	NC006 ■ 35x48x7mm, MVQ (50-319161-00) NB697 ■ 26x42x8mm, FPM (50-306704-00) NB698 ■ 80x98x10mm, FPM (50-319273-00)	NB575 [2]■		 JM5059  JN453  JN626  JN693  JN929  JH5005
HBS002 Ⓢ (22-29098B) M10x1.25x140mm (x10)	JC824 ■ (31-026334-00) JC281 ■ (31-024312-10)	JN626 (31-026099-10)	JH5005 (x2) [116] (31-027194-00) JJ120 (x2)	PA565 (x8) (50-305900-50) HR342 ■ (24-30590-05/0)	NC006 ■ 35x48x7mm, MVQ (50-319161-00) NB697 ■ 26x42x8mm, FPM (50-306704-00) NB698 ■ 80x98x10mm, FPM (50-319273-00)	NB575 [2]■		 JM5059  JN453  JN626  JN693  JN929  JH5005
HBS002 Ⓢ (22-29098B) M10x1.25x140mm (x10)	JC823 ■ (31-027191-10) JC281 ■ (31-024312-10)	JN929 (50-027192-10)	JH5005 [116] (31-027194-00)	PA565 (x8) (50-305900-50) HR342 ■ (24-30590-05/0)	NC006 ■ 35x48x7mm, MVQ (50-319161-00) NB697 ■ 26x42x8mm, FPM (50-306704-00) NB698 ■ 80x98x10mm, FPM (50-319273-00)			 JM5059  JN453  JN626  JN693  JN929  JH5005
HBS002 Ⓢ (22-29098B) M10x1.25x140mm (x10)	JC824 ■ (31-026334-00) JC281 ■ (31-024312-10) JE120 Ⓢ (31-024767-00)	JN626 (31-026099-10)	JH5005 (x2) [116] (31-027194-00) JJ120 (x2)	PA565 (x8) (50-305900-50) HR342 ■ (24-30590-05/0)	NC006 ■ 35x48x7mm, MVQ (50-319161-00) NB697 ■ 26x42x8mm, FPM (50-306704-00) NB698 ■ 80x98x10mm, FPM (50-319273-00)	NB575 [2]■		 JM5059  JN453  JN626  JN693  JN929  JH5005









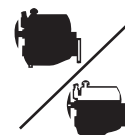



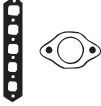

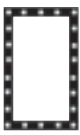

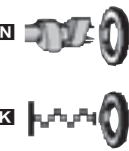

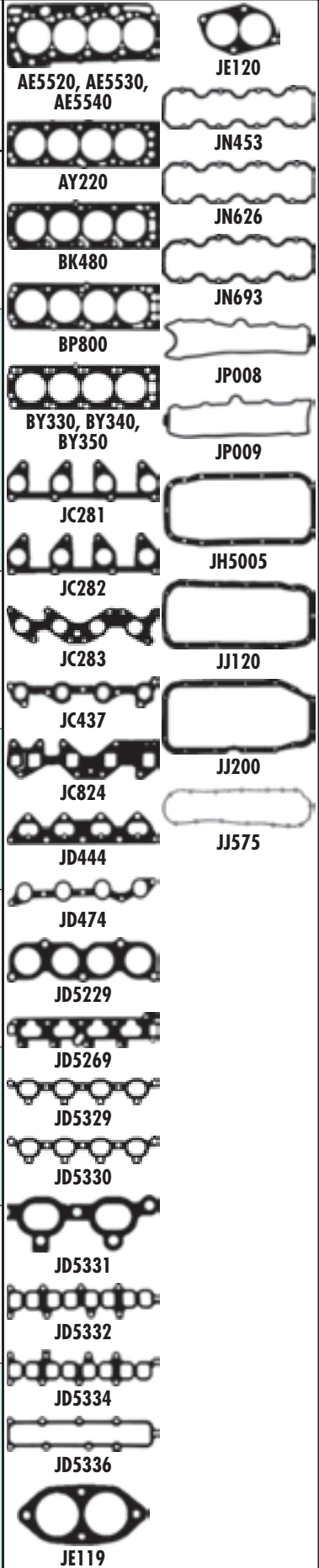





























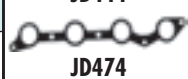

























































cc



KW/PS



Astra 1.6L i 16V				01/94 → 09/98		32	AY220 (Fibre)	CY221 (21-27986-22/0)	EY230 (22-27665-01/0)
X 16 XEL	1598	4	79.00	Injection, DOHC		74/100			
Astra 1.6L S				09/81 → 08/86		33	BK480 (Fibre)	DK480 (21-24578-22/0)	
16 SH	1598	4	80.00	Carburettor, SOHC		66/89	(30-024578-10)		
Astra Convertible 1.6L i				10/87 → 08/93		34	BP800 (Fibre)	DP802 (21-25706-25/0)	EK484 [129] (22-27194-01/0)
C 16 NZ/E 16 NZ	1598	4	79.00	SPi, SOHC		55/75	(30-025706-20)		
C 16 LZ	1598	4	80.00			55/75			
Astra 1.7L CDTI Diesel				03/04 →		35	AE5520 (MLS), 1.45mm, 1 Hole	CE5522▲ (21-29904-22/0)	EE5520 (22-29904-00/0)
Astra 1.7L CDTI 16V Diesel				04/03 →			(30-029904-00)		
Z 17 DTL	1686	4	79.00	CDTI, DOHC		59/80	AE5530 (MLS), 1.50mm, 2 Holes (30-029905-00)		
Z 17 DTL	1686	4	79.00		59/80	AE5540 (MLS), 1.55mm, 3 Notches (30-029906-00)			
Astra 1.7L CDTI Diesel				03/04 →		36	AE5520 (MLS), 1.45mm, 1 Hole	CE5523▲ (21-29904-23/0)	EE5520 (22-29904-00/0)
Z 17 DTH	1686	4	79.00	Direct Injection, DOHC		74/100	(30-029904-00) AE5530 (MLS), 1.50mm, 2 Holes (30-029905-00) AE5540 (MLS), 1.55mm, 3 Notches (30-029906-00)		
Astra 1.7L D Diesel				02/89 → 02/98		37	BY330 (Fibre), 1.30mm	DL011▲ (21-26198-20/0)	EK485 (22-25011-04/0)
17 D	1699	4	82.50	Indirect Injection, SOHC		42/57	(30-027492-10) BY340 (Fibre), 1.40mm, 1 Notch (30-027493-10) BY350 (Fibre), 1.50mm, 2 Notches (30-027494-10)		
Astra 1.7L D Diesel				01/89 → 09/98		38	BY330 (Fibre), 1.30mm	DL011▲ (21-26198-20/0)	EK485 (22-25011-04/0)
17 DR	1699	4	82.50	Indirect Injection, SOHC		44/ 57-60	(30-027492-10) BY340 (Fibre), 1.40mm, 1 Notch (30-027493-10) BY350 (Fibre), 1.50mm, 2 Notches (30-027494-10)		
Astra 1.7L DTI 16V Diesel				02/00 →		39	AE5520 (MLS), 1.45mm, 1 Hole	CE5521▲ (21-29904-21/0)	EE5520 (22-29904-00/0)
Y 17 DT	1686	4	79.00	Direct Injection, DOHC		55/75	(30-029904-00) AE5530 (MLS), 1.50mm, 2 Holes (30-029905-00) AE5540 (MLS), 1.55mm, 3 Notches (30-029906-00)		











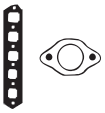

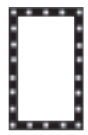

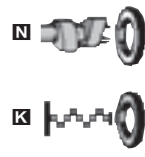

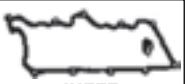



















								
HBS055  (22-29012B) M10x1.25x153mm (x10)	JD5269  (31-027984-00) JD5229  (31-028463-00) JD444  (31-027878-00)	JP009  (50-027983-00) JP008  (50-027982-00)	JJ575 [148] (50-027665-00)	HR791  24-30614-76/0	NC006  (x2) 35x48x7mm, MVQ (50-319161-00) NB697  26x42x8mm, FPM (50-306704-00) NB698  80x98x10mm, FPM (50-319273-00)			AE5520, AE5530, AE5540  JE120  JN453  AY220  BK480  JN626  JN693  BP800  JP008  BY330, BY340, BY350  JP009  JC281  JH5005  JC282  JJ120  JC283  JJ200  JC437  JJ200  JC824  JJ575  JD444  JD474  JD5229  JD5269  JD5329  JD5330  JD5331  JD5332  JD5333  JD5336  JE119 
HBS003  (22-29009B) M11x1.25x140mm (x10)	JC283  (31-025183-10) JC282  (31-024625-20) JE120  (31-024767-00)	JN453 [127] (31-024572-00)	JJ200 (31-025011-00)	HR343  (24-30602-50/0)	NC006  35x48x7mm, MVQ (50-319161-00) NB700  31x50x8mm, FPM (50-306551-50) NB701  86x104x11mm, FPM (50-306261-50) →12/85 NB806  90x104x11mm, FPM (50-306552-00) 01/86 →	NB575 [2] 		
HBS002  (22-29008B) M10x1.25x140mm (x10)	JC824  (31-026334-00) JC281  (31-024312-10)	JN626 (31-026099-10)	JH5005 (x2) [116] (31-027194-00) JJ120 (x2)	PA565 (x8) (50-305900-50) HR342  (24-305900-50/0)	NC006  35x48x7mm, MVQ (50-319161-00) NB697  26x42x8mm, FPM (50-306704-00) NB698  80x98x10mm, FPM (50-319273-00)	NB575 [2] 		
HBS036  (22-29001B) M12x1.5x102mm (x10)	JD5334  (31-029914-00) JD5330  (31-029910-00)	JM5198 (50-029908-00)		HR791  24-30614-76/0	NB884 38x50x5.5mm, FPM (50-319010-00) NJ449  40x52x6mm, NBR (50-319266-00) NK103  87x100x8.5mm, FPM			
HBS036  (22-29001B) M12x1.5x102mm (x10)	JD5334  (31-029914-00) JD5331  (x2) (31-029911-00)	JM5198 (50-029908-00)		HR791  24-30614-76/0	NB884 38x50x5.5mm, FPM (50-319010-00) NJ449  40x52x6mm, NBR (50-319266-00) NK103  87x100x8.5mm, FPM			
HBS074  (22-29100B) M11x1.25x154mm (x10)	JD474  JC437  (31-024854-10) JE119  (31-024520-00)	JN693 [128] (31-026198-10)	JJ200 (31-025011-00)	HR343  (24-30602-50/0)	NC006  35x48x7mm, MVQ (50-319161-00) NB734  35x50x8mm, FPM NB806  90x104x11mm, FPM (50-306552-00)	NA5271 [70] NB575 [2] 		
HBS074  (22-29100B) M11x1.25x154mm (x10)	JD474  JC437  (31-024854-10) JE119  (31-024520-00)	JN693 [128] (31-026198-10)	JJ200 (31-025011-00)	HR343  (24-30602-50/0)	NC006  35x48x7mm, MVQ (50-319161-00) NB734  35x50x8mm, FPM NB806  90x104x11mm, FPM (50-306552-00)	NB575 [2] 		
HBS036  (22-29001B) M12x1.5x102mm (x10)	JD5332  (31-029912-00) →Eng.721439 JD5333  (31-029913-00) Eng.721439 → JD5336  (31-029916-00) Eng.721439 → JD5329  (31-029909-00)	JM5197 (50-029907-00)		HR791  24-30614-76/0	NB884 38x50x5.5mm, FPM (50-319010-00) NJ449  40x52x6mm, NBR (50-319266-00) NK103  87x100x8.5mm, FPM			



KW/PS



Astra 1.7L TD Diesel		01/94 → 08/00		40		AY160 (MLS), 1.30mm (30-028498-00) AY170 (MLS), 1.40mm, 1 Notch (30-028499-00) AY180 (MLS), 1.50mm, 2 Notches (30-028500-00)		DL012▲ (21-27879-20/0)		EK486 [6] (22-28498-00/0)	
X 17 DTL	1699	4	82.50	Direct Injection, SOHC	50/68						
Astra 1.7L TD Diesel		12/91 → 09/98		41		AB5010 (MLS), 1.40mm (30-029163-00) AB5020 (MLS), 1.45mm, 1 Hole (30-029164-00) AB5030 (MLS), 1.50mm, 2 Holes (30-029165-00)		CY811▲■ (21-27776-22/0)		FY811▲ (20-27776-02/0)	
17 DT (TC4EE1)	1686	4	79.00		60/81						
Astra 1.8L		03/04 →		42		AC5460 (MLS) (30-028674-00)		CC5460 (21-28674-20/0)			
Astra 1.8L 16V		02/98 → 09/00									
Astra 1.8L 16V Dualfuel		09/02 →									
Astra Convertible 1.8L 16V		03/01 →									
Astra Coupe 1.8L 16V		03/00 → 10/00									
Astra Coupe 1.8L 16V Dualfuel		09/02 →									
X 18 XE1	1796	4	80.50	Injection, DOHC	85/116						
Z 18 XE	1799	4	80.50	Injection, DOHC	87-92/ 118- 125						
Astra 1.8L GTE		03/83 → 08/86		43		BM380 (Fibre) (30-024765-10)		DM381 (21-24765-23/0)			
18 E	1796	4	84.80	Injection, SOHC	85/115						
Astra 1.8L GTE		09/84 → 08/91		44		BM380 (Fibre) (30-024765-10) → Eng.14360690 BP810 (Fibre) (30-025818-10) Eng.14360691 →		DM381 (21-24765-23/0) → Eng.14360690 DP811 (21-25818-23/0) Eng.14360691 →		EK482 (22-26131-01/0) Eng.14360691 →	
18 SE	1796	4	84.80	Injection, SOHC	82/111						
18 E	1796	4	84.80	Injection, SOHC	85/115						
Astra 1.8L i		09/91 → 09/98		45		BP810 (Fibre) (30-025818-10)		DP810 (21-25818-22/0)		EK482 (22-26131-01/0)	
C 18 NZ	1796	4	84.80	SPi, SOHC	66/89						
Astra 1.8L i		01/90 → 08/91		46		BM380 (Fibre) (30-024765-10)		DM381 (21-24765-23/0)			
18 E	1796	4	84.80	Injection, SOHC	85/115						
Astra 1.8L i 16V		06/93 → 02/98		47		BY240 (Fibre) (30-027682-00)		DY241 (21-27682-20/0)		EC130 (22-28793-00/0)	
C 18 XE	1799	4	81.60	Injection, DOHC	92/125						







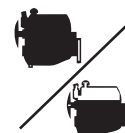



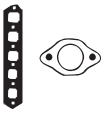

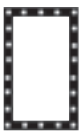

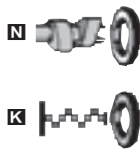

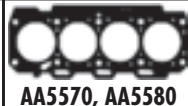













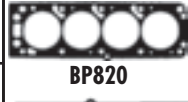

















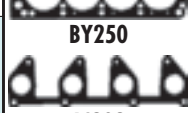

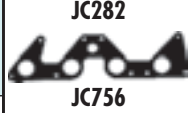











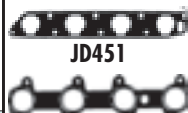























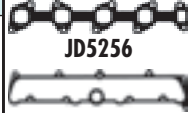











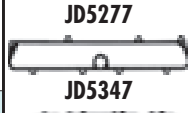









								
HBS074 Ⓢ (22-29100B) M11x1.25x154mm (x10)	JD474 ■ JC437 ■ (31-024854-10)	JP018 (50-027879-00)	JJ574 (50-027842-00)	HR343 ■ (24-30602-50/0)	■ NC006 ■ 35x48x7mm, MVQ (50-319161-00) ■ NB734 ■ 35x50x8mm, FPM ■ NB806 ■ 90x104x11mm, FPM (50-306552-00)			 AB5010, AB5020, AB5030  JN777
HBS036 Ⓢ (22-29001B) M12x1.5x102mm (x10)	JD303 ■ JD304 ■  JE5029 (31-027779-00)	JN777 (50-027776-00)		PA658 (x8) (50-319265-00)	■ NJ449 40x52x6mm, NBR (50-319266-00) ■ NJ449 ■ 40x52x6mm, NBR (50-319266-00) ■ NK103 ■ 87x100x8.5mm, FPM			 AC5460  JP016  AY160, AY170, AY180  JP018
HBS055 Ⓢ (22-29012B) M10x1.25x153mm (x10)	JD5196 ■ (31-029039-00) JD5197 ■ (31-029040-00)	JM5092 (50-029087-00)		HR5048 ■ (24-31938-60/0)	■ NC006 ■ (x2) 35x48x7mm, MVQ (50-319161-00) ■ NC065 ■ 30x40x7mm, FPM (50-306142-00) ■ NB698 ■ 80x98x10mm, FPM (50-319273-00)			 BM380  JJ200  BP810  JJ385  BY240  JJ574  JC282  JC283  JJ615
HBS003 Ⓢ (22-29009B) M11x1.25x140mm (x10)	JC283 ■ (31-025183-10) JC282 ■ (31-024625-20)  JE120 (31-024767-00)	JN453 [127] (31-024572-00)	JJ200 (31-025011-00)	HR343 ■ (24-30602-50/0)	■ NC006 ■ 35x48x7mm, MVQ (50-319161-00) ■ NB700 ■ 31x50x8mm, FPM (50-306551-50) ■ NB701 ■ 86x104x11mm, FPM (50-306261-50)	NB575 [2]■ NB807 [2]■		 JC437  JC756  JC757
HBS003 Ⓢ (22-29009B) M11x1.25x140mm (x10)	JC283 ■ (31-025183-10) →Eng.14360690 JC756 ■ (31-025820-20) Eng.14360691→ JC282 ■ (31-024625-20)	JN453 [127] (31-024572-00) →Eng.14360690 JN693 [128] (31-026198-10) Eng.14360691→	JJ200 (31-025011-00) →Eng.14360690 JJ385 [148] (50-026131-00) Eng.14360691→	HR343 ■ (24-30602-50/0) →Eng.14360690 HR342 ■ (24-30590-05/0) Eng.14360691→	■ NC006 ■ 35x48x7mm, MVQ (50-319161-00) ■ NB700 ■ 31x50x8mm, FPM (50-306551-50) ■ NB701 ■ 86x104x11mm, FPM (50-306261-50) →Eng.14360690 ■ NB806 ■ 90x104x11mm, FPM (50-306552-00) Eng.14360691→	NB575 [2]■ NB807 [2]■		 JD303  JD304  JD451  JD474
HBS003 Ⓢ (22-29009B) M11x1.25x140mm (x10) →12/96 HBS053 Ⓢ (22-29099B) M11x1.25x140mm (x10) 01/97→	JC757 ■ (31-025817-10) JC282 ■ (31-024625-20)	JN693 [128] (31-026198-10)	JJ385 [148] (50-026131-00)	PA565 (x8) (50-305900-50) HR342 ■ (24-30590-05/0)	■ NC006 ■ 35x48x7mm, MVQ (50-319161-00) ■ NB700 ■ 31x50x8mm, FPM (50-306551-50) ■ NB806 ■ 90x104x11mm, FPM (50-306552-00)	NB575 [2]■		 JD5196  JD5197  JE120
HBS003 Ⓢ (22-29009B) M11x1.25x140mm (x10)	JC283 ■ (31-025183-10) JC282 ■ (31-024625-20)  JE120 (31-024767-00)	JN453 [127] (31-024572-00)	JJ200 (31-025011-00)	PA565 (x8) (50-305900-50) HR343 ■ (24-30602-50/0)	■ NC006 ■ 35x48x7mm, MVQ (50-319161-00) ■ NB700 ■ 31x50x8mm, FPM (50-306551-50) ■ NB701 ■ 86x104x11mm, FPM (50-306261-50)	NB575 [2]■ NB807 [2]■		 JM5092  JN453
HBS054 Ⓢ (22-29013B) M11x1.25x105mm (x10)	JD451 ■ (31-027699-00) JD450 ■ (31-027684-00)  JE120 (31-024767-00)	JP016 (50-027683-00)	JJ615 (31-028793-00)	HR791 ■ 24-30614-76/0	■ NC006 ■ (x2) 35x48x7mm, MVQ (50-319161-00) ■ NB700 ■ 31x50x8mm, FPM (50-306551-50) ■ NB806 ■ 90x104x11mm, FPM (50-306552-00)			 JN693



KW/PS

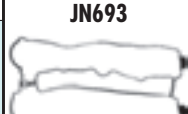

Astra 1.8L i 16V		01/94 → 02/98		48		BY240 (Fibre) (30-027682-00)	DY241 (21-27682-20/0)	EC130 (22-28793-00/0) HC5007 [212] (22-28386-00/0)
Astra Convertible 1.8L 16V		11/94 → 03/01						
C 18 XEL/X 18 XE	1799	4	81.60	Injection, DOHC	85/116			
Astra 1.9L CDTI Diesel		06/04 →		49		AD5840 (MLS), 0.82mm, 0 Holes (30-029766-00) AD5850 (MLS), 0.92mm, 1 Hole (30-029767-00) AD5860 (MLS), 1.02mm, 2 Holes (30-029768-00)	CD5840▲ (21-29766-20/0)	EE5181 (22-29832-01/0)
Astra 1.9L CDTI 16V Diesel		04/04 →						
Z 19 DTJ	1910	4	82.00	Direct Injection, DOHC	88/120			
Z 19 DTH	1910	4	82.00	Direct Injection	110/150			
Astra 1.9L CDTI Diesel		08/05 →		50		AA5570 (MLS), 0.92mm, 1 Hole (30-029094-10) AA5580 (MLS), 1.02mm, 2 Holes (30-029095-10)	CG7390▲ (21-30144-00/0)	EE5181 (22-29832-01/0)
Z 19 DT	1910	4	82.00	Direct Injection	74-88/ 100- 120			
Astra 2.0L		02/06 → 09/06		51		AG9570 (MLS) (30-030342-00)	CG9570 (21-30342-00/0)	EG9570
Astra 2.0L Turbo		03/04 →						
Z 20 LEL	1998	4	86.00	Injection	125/170			
Z 20 LER	1998	4	86.00	Injection, DOHC	147/200			
Astra 2.0L Turbo		03/05 →		52				EG9570
Z 20 LEH	1998	4	86.00	Injection, DOHC	177/240			
Astra 2.0L 16V		02/98 →		53		BY250 (Fibre) (30-027987-10)	DY250 (21-27987-20/0)	EC130 (22-28793-00/0) HC5007 [212] (22-28386-00/0)
Astra 2.0L i 16V		01/94 → 09/98						
X 20 XEV	1998	4	86.00	Injection, DOHC	100/136			
Astra 2.0L DI Diesel		02/98 →		54		AB5671 (MLS), 1.30mm, 1 Notch AB5681 (MLS), 1.40mm, 2 Notches	CB5670▲■ (21-29011-20/0)	EB5670 (22-29011-00/0)
X 20 DTL/Y 20 DTL		02/98 →						
X 20 DTL	1995	4	84.00	Direct Injection	60/81			
Astra 2.0L DTI 16V Diesel		08/99 →		55		AB5671 (MLS), 1.30mm, 1 Notch AB5681 (MLS), 1.40mm, 2 Notches	CB5670▲■ (21-29011-20/0) X20DTH CB5671▲■ (21-29011-21/0) Y20DTH	EB5670 (22-29011-00/0)
X 20 DTH/Y 20 DTH		08/99 →						
X 20 DTH	1995	4	84.00	Direct Injection	74/100			
Astra 2.0L GTE		09/86 → 08/91		56		BP820 (Fibre) (30-025819-10)	DP820 (21-25819-21/0)	EK482 (22-26131-01/0)
Astra 2.0L i		09/91 → 09/98						
Astra Convertible 2.0L i		01/91 → 10/94						
C 20 NE	1998	4	86.00	Injection, SOHC	85/115			
20 SEH	1998	4	86.00	Injection, SOHC	95/129			







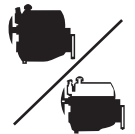



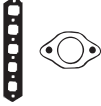

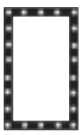

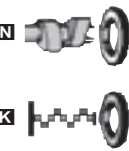























































































								 AA5570, AA5580	 JJ615
HBS054  (22-29013B) M11x1.25x105mm (x10)	JD451  (31-027699-00) JD450  (31-027684-00)  JE120 (31-024767-00)	JP016 (50-027683-00)	JJ615 (31-028793-00) JJ616  [212] (31-028386-00) JJ617  [212] (31-028385-00)	HR791  24-30614-76/0	 NC006  (x2) 35x48x7mm, MVQ (50-319161-00)  NB700  31x50x8mm, FPM (50-306551-50)  NB806  90x104x11mm, FPM (50-306552-00)			 BP820	 JJ616
HBS370  (22-17026B) M12x1.25x225mm (x10)	JD5376  (31-029969-00)	JM7055 (Steel Elastomer)		HR5095 	 NA5053 30x42x7mm, FPM (50-319488-00)  NA5070  31x41x7mm, FPM (50-319524-00)		HL5031 [245] 	 BY240	 JJ617
HBS227  (22-17018B) M12x1.25x218mm (x10)	JD468  (31-028377-00) (MLS)	JM7055 (Steel Elastomer)		HR363 	 NA5053 30x42x7mm, FPM (50-319488-00)  NA5070  31x41x7mm, FPM (50-319524-00)		HL5031 [245] 	 BY250	
	JD5903  (31-030367-00) (MLS)							 JC282	
HBS054  (22-29013B) M11x1.25x105mm (x10)	JD451  (31-027699-00) JD5903  (31-030367-00) (MLS)	JP016 (50-027683-00)	JJ616 (31-028386-00) JJ617  (31-028385-00)	HR791  24-30614-76/0	 NC006  (x2) 35x48x7mm, MVQ (50-319161-00)  NB700  31x50x8mm, FPM (50-306551-50)  NB806  90x104x11mm, FPM (50-306552-00)			 JC756	
HBS054  (22-29013B) M11x1.25x105mm (x10)	JD451  (31-027699-00) JD450  (31-027684-00)  JE120 (31-024767-00)	JP016 (50-027683-00)	JJ615 (31-028793-00) JJ616  [212] (31-028386-00) JJ617  [212] (31-028385-00)	HR791  24-30614-76/0	 NC006  (x2) 35x48x7mm, MVQ (50-319161-00)  NB700  31x50x8mm, FPM (50-306551-50)  NB806  90x104x11mm, FPM (50-306552-00)			 JD451	
HBS298  (22-29016B) M12x1.50x235mm (x10)	JD5255  (31-029721-00) JD5347   (31-029942-00) JD5256  (31-029722-00)	JM5159 (50-029633-00)	JH5057 (31-029575-00)	HR791  24-30614-76/0	 NA5069  55x68x8mm, FPM (50-319515-00)  NA5209  99x114x11mm, FPM (50-319514-00)			 JD468	
HBS298  (22-29016B) M12x1.50x235mm (x10)	JD5255  (31-029721-00) JD5277   (31-029723-00) Y20DTH JD5347   (31-029942-00) X20DTH JD5256  (31-029722-00)	JM5159 (50-029633-00)	JH5057 (31-029575-00)	HR791  24-30614-76/0	 NA5069  55x68x8mm, FPM (50-319515-00)  NA5209  99x114x11mm, FPM (50-319514-00)			 JD5255	
HBS003  (22-29009B) M11x1.25x140mm (x10)	JC756  (31-025820-20) JC282  (31-024625-20)  JE120 (31-024767-00)	JN693 [128] (31-026198-10)	JJ385 (x2) [148] (50-026131-00)	PA565 (x8) (50-305900-50) HR342  (24-30590-05/0)	 NC006  35x48x7mm, MVQ (50-319161-00)  NB700  31x50x8mm, FPM (50-306551-50)  NB806  90x104x11mm, FPM (50-306552-00)	NB575 [2]  NB807 [2] 		 JD5347	
								 JD5376	
								 JE120	
								 JM5159	
								 JN693	
								 JP016	
								 JH5057	
								 JJ385	



KW/PS



Astra 2.0L GTE 16V				05/88 → 08/91		57	BS720 (Fibre) (30-026310-10)	DS720 (21-26310-22/0)	ES720 (22-27206-00/0)
20 XE	1998	4	86.00	Injection, DOHC	115/156				
Astra 2.0L i				09/91 → 02/98		58	BP820 (Fibre) (30-025819-10)	DP820 (21-25819-21/0)	EK482 (22-26131-01/0)
C 20 NE	1998	4	86.00	Injection, SOHC	85/115				
Astra 2.0L i 16V				09/91 → 02/98		59	BS720 (Fibre) (30-026310-10)	DS720 (21-26310-22/0)	ES720 (22-27206-00/0)
C 20 XE	1998	4	86.00	Injection, DOHC	110/150				
Astra 2.0L SRI Turbo				07/02 →		60	AG9570 (MLS) (30-030342-00)	CG9570 (21-30342-00/0)	EG9570
Astra Convertible 2.0L Turbo				03/02 →					
Astra Coupe 2.0L 16V Turbo				09/00 →					
Z 20 LET	1998	4	86.00	Injection, DOHC	140- 147/ 190- 200				
Astra 2.0L Turbo				03/04 →		61	AG9570 (MLS) (30-030342-00)	CG9570 (21-30342-00/0)	EG9570
Z 20 LEL	1998	4	86.00	Injection	125/170				
Astra Convertible 2.0L i				01/87 → 12/91		62	BP820 (Fibre) (30-025819-10)	DP820 (21-25819-21/0)	EK482 (22-26131-01/0)
20 NE	1998	4	86.00	Injection, SOHC	85/116				
Astra 2.2L 16V				03/01 →		63	AG9580 (MLS) (30-030344-00)	CG9580 (21-30344-00/0)	
Astra Convertible 2.2L 16V				03/01 →					
Astra Coupe 2.2L 16V				03/00 →					
Z 22 SE	2198	4	86.00	Injection, DOHC	108/147				
Astravan 1.4L i				01/91 → 10/94		64	BS260 (Fibre) (30-026329-10)	DS260 (21-26329-21/0)	EK470 (22-27194-05/0)
C 14 NZ	1389	4	77.60	SPi, SOHC	44/60				











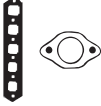

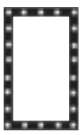

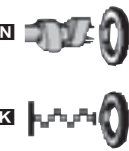









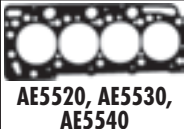

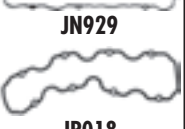





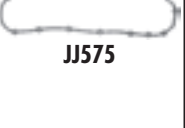









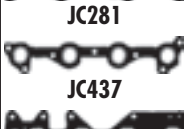

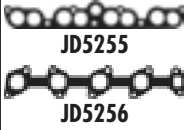
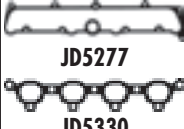
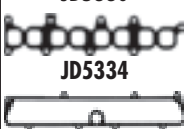



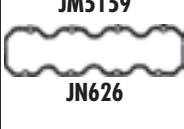



































































								
HBS035  [22-29005B] M11x1.25x110mm (x10) →Eng.14137011 HBS054  [22-29013B] M11x1.25x105mm (x10) Eng.14137012→	JD455  [31-026335-10] JD430  [31-025888-00]	JM950 [50-026336-10]	JJ459 [148] [31-027206-00]	PA565 (x16) [50-305900-50] HR342  (x2) [24-305900-05/0]	NC006  (x2) 35x48x7mm, MVQ [50-319161-00] NB884  38x50x5.5mm, FPM [50-319010-00] NB806  90x104x11mm, FPM [50-306552-00]	NB575 [2] 	 BP820  BS260  BS720  JC281  JC282  JC756  JC824  JD430  JD451  JD455  JE120  JM950  JN626  JN693  JP016  JH5005  JJ120  JJ385  JJ459	 JJ616  JJ617
HBS003  [22-29009B] M11x1.25x140mm (x10) →12/96 HBS053  [22-29099B] M11x1.25x140mm (x10) 01/97→	JC756  [31-025820-20] JC282  [31-024625-20]  JE120 [31-024767-00]	JN693 [128] [31-026198-10]	JJ385 (x2) [148] [50-026131-00]	PA565 (x8) [50-305900-50] HR342  (x2) [24-305900-05/0]	NC006  35x48x7mm, MVQ [50-319161-00] NB700  31x50x8mm, FPM [50-306551-50] NB806  90x104x11mm, FPM [50-306552-00]	NB575 [2] 		
HBS035  [22-29005B] M11x1.25x110mm (x10) →Eng.14137011 HBS054  [22-29013B] M11x1.25x105mm (x10) Eng.14137012→	JD455  [31-026335-10] JD430  [31-025888-00]	JM950 [50-026336-10]	JJ459 (x2) [148] [31-027206-00]	PA565 (x16) [50-305900-50] HR342  (x2) [24-305900-05/0]	NC006  (x2) 35x48x7mm, MVQ [50-319161-00] NB884  38x50x5.5mm, FPM [50-319010-00] NB806  90x104x11mm, FPM [50-306552-00]	NB575 [2] 		
HBS054  [22-29013B] M11x1.25x105mm (x10)	JD451  [31-027699-00] JD5903  [31-030367-00] (MLS)	JP016 [50-027683-00]	JJ616 [31-028386-00] JJ617  [31-028385-00]	HR791  24-30614-76/0	NC006  (x2) 35x48x7mm, MVQ [50-319161-00] NB700  31x50x8mm, FPM [50-306551-50] NB806  90x104x11mm, FPM [50-306552-00]		 JM950  JN626  JN693	
HBS054  [22-29013B] M11x1.25x105mm (x10)	JD451  [31-027699-00] JD5903  [31-030367-00] (MLS)	JP016 [50-027683-00]	JJ616  [31-028386-00] JJ617  [31-028385-00]	HR791  24-30614-76/0	NC006  (x2) 35x48x7mm, MVQ [50-319161-00] NB700  31x50x8mm, FPM [50-306551-50] NB806  90x104x11mm, FPM [50-306552-00]		 JP016  JH5005  JJ120  JJ385  JJ459	
HBS003  [22-29009B] M11x1.25x140mm (x10)	JC756  [31-025820-20] JC282  [31-024625-20]  JE120 [31-024767-00]	JN693 [128] [31-026198-10]	JJ385 [148] [50-026131-00]	PA565 (x8) [50-305900-50] HR342  (x2) [24-305900-05/0]	NC006  35x48x7mm, MVQ [50-319161-00] NB700  31x50x8mm, FPM [50-306551-50] NB806  90x104x11mm, FPM [50-306552-00]	NB575 [2]  NB807 [2] 		
HBS416  [22-29025B] M11x1.50x163mm (x10)	KG5337  [50-350435-00] (MVQ) JD5868  [31-030346-00]				NC006 35x48x7mm, MVQ [50-319161-00] NA5108  42x55x7mm, FPM [50-319392-00] NB806  90x104x11mm, FPM [50-306552-00]			
HBS002  [22-29098B] M10x1.25x140mm (x10)	JC824  [31-026334-00] JC281  [31-024312-10]	JN626 [31-026099-10]	JH5005 [116] [31-027194-00] JJ120	PA565 (x8) [50-305900-50] HR342  (x2) [24-305900-05/0]	NC006  35x48x7mm, MVQ [50-319161-00] NB697  26x42x8mm, FPM [50-306704-00] NB698  80x98x10mm, FPM [50-319273-00]	NB575 [2] 		



KW/PS



Astravan 1.6L i				01/91 → 08/98	65	BP800 (Fibre) (30-025706-20)	DP802 (21-25706-25/0)	EK484 [129] (22-27194-01/0)
C 16 NZ	1598	4	79.00	SPi, SOHC	55/75			
Astravan 1.6L i				02/94 → 10/96	66	BP800 (Fibre) (30-025706-20)	DP802 (21-25706-25/0)	ES260 [248] (22-27194-00/0)
X 16 SZ	1598	4	79.00	SPi, SOHC	52/71			
Astravan 1.6L i				08/98 → 09/00	67	BP800 (Fibre) (30-025706-20)	DP806 (21-25706-30/0)	ES260 [211] (22-27194-00/0) EY230 [210] (22-27665-01/0)
X 16 SZR	1598	4	79.00	SPi, SOHC	55/75			
Astravan 1.6L i				09/00 →	68	AE5920 (Steel) (30-029996-00)	CE5920 (21-29996-20/0)	EB5541 [8] (22-27665-03/0)
Z 16 SE	1598	4	79.00	Injection, SOHC	62-64/ 84-87			
Astravan 1.7L CDTI Diesel				04/04 →	69	AE5520 (MLS), 1.45mm, 1 Hole (30-029904-00) AE5530 (MLS), 1.50mm, 2 Holes (30-029905-00) AE5540 (MLS), 1.55mm, 3 Notches (30-029906-00)	CE5522▲ (21-29904-22/0)	EE5520 (22-29904-00/0)
Z 17 DTL	1686	4	79.00	CDTI, DOHC	59/80			
Astravan 1.7L D Diesel				01/91 → 08/94	70	BY330 (Fibre), 1.30mm (30-027492-10) BY340 (Fibre), 1.40mm, 1 Notch (30-027493-10) BY350 (Fibre), 1.50mm, 2 Notches (30-027494-10)	DL011▲ (21-26198-20/0)	EK485 (22-25011-04/0)
17 DR	1699	4	82.50	Indirect Injection, SOHC	44/ 57-60			
Astravan 1.7L TD Diesel				01/94 → 08/98	71	AY160 (MLS), 1.30mm (30-028498-00) AY170 (MLS), 1.40mm, 1 Notch (30-028499-00) AY180 (MLS), 1.50mm, 2 Notches (30-028500-00)	DL012▲ (21-27879-20/0)	EK486 [6] (22-28498-00/0)
X 17 DTL	1699	4	82.50	Direct Injection, SOHC	50/68			
Astravan 2.0L DI Diesel				08/98 →	72	AB5671 (MLS), 1.30mm, 1 Notch AB5681 (MLS), 1.40mm, 2 Notches	CB5670▲■ (21-29011-20/0)	EB5670 (22-29011-00/0)
X 20 DTL	1995	4	84.00	Direct Injection	60/81			
Astravan 2.0L DTI Diesel				04/04 →	73	AB5671 (MLS), 1.30mm, 1 Notch AB5681 (MLS), 1.40mm, 2 Notches	CB5671▲■ (21-29011-21/0)	EB5670 (22-29011-00/0)
Y 20 DTH	1995	4	84.00	Direct Injection	74/100			
Belmont 1.3L				09/85 → 08/91	74	BK470 (Fibre) (30-024033-10)	DK471 (21-24033-30/0)	EK470 (22-27194-05/0)
13 S	1297	4	75.00	Carburettor, SOHC	42-55/ 57-75			







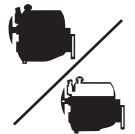



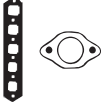

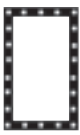

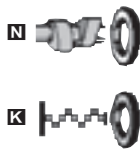













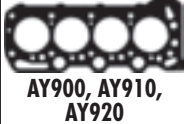





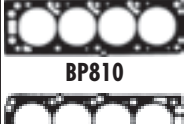



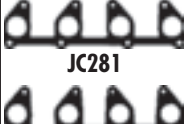









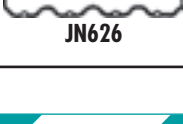















































								
HBS002  (22-29098B) M10x1.25x140mm (x10)	JC824  (31-026334-00) JC281  (31-024312-10)	JN626 (31-026099-10)	JH5005 (x2)  (31-027194-00) JJ120 (x2)	PA565 (x8) (50-305900-50) HR342  (24-30590-05/0)	NC006  35x48x7mm, MVQ (50-319161-00) NB697  26x42x8mm, FPM (50-306704-00) NB698  80x98x10mm, FPM (50-319273-00)		NB575 	 AE5520, AE5530, AE5540  JN693  JN929  JP018  AY160, AY170, AY180  JH5005  BK470  JH5057  BP800  BY330, BY340, BY350  JJ120  JC280  JC281  JC437  JJ574  JC824  JJ575  JD474  JD5255  JD5256  JD5277  JD5330  JD5334  JD5347  JD5398  JD5399  JE119  JM5159  JN626
HBS002  (22-29098B) M10x1.25x140mm (x10)	JC824  (31-026334-00) JC281  (31-024312-10)	JN626 (31-026099-10)	JH5005  (31-027194-00)	PA565 (x8) (50-305900-50) HR342  (24-30590-05/0)	NC006  35x48x7mm, MVQ (50-319161-00) NB697  26x42x8mm, FPM (50-306704-00) NB698  80x98x10mm, FPM (50-319273-00)		NB575 	
HBS002  (22-29098B) M10x1.25x140mm (x10)	JC824  (31-026334-00) JC281  (31-024312-10)	JN929 (50-027192-10)	JH5005  (31-027194-00) JJ575  (50-027665-00)	PA565 (x8) (50-305900-50) HR342  (24-30590-05/0)	NC006  35x48x7mm, MVQ (50-319161-00) NB697  26x42x8mm, FPM (50-306704-00) NB698  80x98x10mm, FPM (50-319273-00)			
HBS002  (22-29098B) M10x1.25x140mm (x10)	JD5398  (31-029997-00) JD5399  (31-029998-00)	JN929 (50-027192-10)		PA565 (x8) (50-305900-50) HR342  (24-30590-05/0)	NC006  35x48x7mm, MVQ (50-319161-00) NB697  26x42x8mm, FPM (50-306704-00) NB698  80x98x10mm, FPM (50-319273-00)			
HBS036  (22-29001B) M12x1.5x102mm (x10) HBS370  (22-17026B) M12x1.25x225mm (x10)	JD5334  (31-029914-00) JD5330  (31-029910-00)	JM5198 (50-029908-00)		HR791  24-30614-76/0	NB884  38x50x5.5mm, FPM (50-319010-00) NJ449  40x52x6mm, NBR (50-319266-00) NK103  87x100x8.5mm, FPM			
HBS074  (22-29100B) M11x1.25x154mm (x10)	JD474  JC437  (31-024854-10)  JE119 (31-024520-00)	JN693  (31-026198-10)	JJ200 (31-025011-00)	HR343  (24-30602-50/0)	NC006  35x48x7mm, MVQ (50-319161-00) NB734  35x50x8mm, FPM NB806  90x104x11mm, FPM (50-306552-00)		NB575 	
HBS074  (22-29100B) M11x1.25x154mm (x10)	JD474  JC437  (31-024854-10) JD5915  (31-028013-00)	JP018 (50-027879-00)	JJ574 (50-027842-00)	HR343  (24-30602-50/0)	NC006  35x48x7mm, MVQ (50-319161-00) NB734  35x50x8mm, FPM NB806  90x104x11mm, FPM (50-306552-00)			
HBS298  (22-29016B) M12x1.50x235mm (x10)	JD5255  (31-029721-00) JD5347  (31-029942-00) JD5256  (31-029722-00)	JM5159 (50-029633-00)	JH5057 (31-029575-00)	HR791  24-30614-76/0	NA5069  55x68x8mm, FPM (50-319515-00) NA5209  99x114x11mm, FPM (50-319514-00)			
HBS298  (22-29016B) M12x1.50x235mm (x10)	JD5255  (31-029721-00) JD5277  (31-029723-00) JD5256  (31-029722-00)	JM5159 (50-029633-00)	JH5057 (31-029575-00)	HR791  24-30614-76/0	NA5069  55x68x8mm, FPM (50-319515-00) NA5209  99x114x11mm, FPM (50-319514-00)			
HBS002  (22-29098B) M10x1.25x140mm (x10)	JC280  (31-024313-10) JC281  (31-024312-10)  JE119 (31-024520-00)	JN626 (31-026099-10)	JH5005  (31-027194-00) JJ120	PA565 (x8) (50-305900-50) HR342  (24-30590-05/0)	NC006  35x48x7mm, MVQ (50-319161-00) NB697  26x42x8mm, FPM (50-306704-00) NB698  80x98x10mm, FPM (50-319273-00)		NB575 	



KW/PS



Belmont 1.4L i				01/90 → 12/91		75	BS260 (Fibre) (30-026329-10)		DS260 (21-26329-21/0)	EK470 (22-27194-05/0)
C 14 NZ	1389	4	77.60	SPi, SOHC		44/60				
Belmont 1.5L DT Diesel				01/87 → 08/90		76	AY840 (MLS), 1.40mm (30-028998-00) → Eng.975024		CY811▲■ (21-27776-22/0)	FY811▲ (20-27776-02/0)
15 DT (T4EC1)	1488	4	76.00	SOHC		49-53/ 67-72				
15 DT	1488	4	76.00	Indirect Injection, SOHC		53/72	AY850 (MLS), 1.45mm, 1 Hole (30-028999-00) → Eng.975024			
							AY860 (MLS), 1.50mm, 2 Holes (30-029000-00) → Eng.975024			
							AY900 (MLS), 1.40mm (30-029007-00) Eng.975025 →			
							AY910 (MLS), 1.45mm, 1 Hole (30-029006-00) Eng.975025 →			
							AY920 (MLS), 1.50mm, 2 Holes (30-029008-00) Eng.975025 →			
Belmont 1.6L				09/85 → 08/91		77	BK480 (Fibre) (30-024578-10)		DK480 (21-24578-22/0)	
16 SH	1598	4	80.00	Carburettor, SOHC		66/89				
Belmont 1.6L D Diesel				09/85 → 08/91		78	BLO10 (Fibre), 1.40mm (30-025124-10) → +0.75mm		DL010▲ (25-24572-02/0) → 12/85	EK481 (22-25011-00/0) → 12/85
16 DA	1598	4	80.00	Direct Injection, SOHC		40/54	BLO20 (Fibre), 1.50mm, 1 Notch (30-025125-10) → 0.75 → 0.85mm	DL011▲ (21-26198-20/0) 01/86 →	EK485 (22-25011-04/0) 01/86 →	
							BLO30 (Fibre), 1.60mm, 2 Notches (30-025126-10) → 0.85mm →			
Belmont 1.6L S				01/89 → 12/91		79	BP800 (Fibre) (30-025706-20)		DP800 (21-25706-26/0)	EK484 [129] (22-27194-01/0)
16 SV	1598	4	79.00			60/82				
Belmont 1.7L D Diesel				01/89 → 12/91		80	BY330 (Fibre), 1.30mm (30-027492-10)		DL011▲ (21-26198-20/0)	EK485 (22-25011-04/0)
17 D	1699	4	82.50	Indirect Injection, SOHC		42/57	BY340 (Fibre), 1.40mm, 1 Notch (30-027493-10)			
							BY350 (Fibre), 1.50mm, 2 Notches (30-027494-10)			
Belmont 1.8L				01/86 → 12/90		81	BP810 (Fibre) (30-025818-10)		DP811 (21-25818-23/0)	EK482 (22-26131-01/0)
18 SE	1796	4	84.80	Injection, SOHC		82/111				











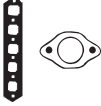

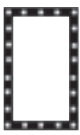

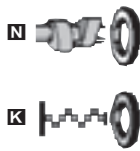

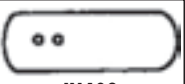

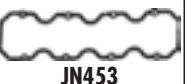





























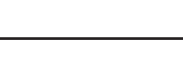













								
HBS002  (22-29098B) M10x1.25x140mm (x10)	JC824  (31-026334-00) JC281  (31-024312-10)	JN626 (31-026099-10)	JH5005 [116] (31-027194-00) JJ120	PA565 (x8) (50-305900-50) HR342  (24-30590-05/0)	NB697  (50-306704-00) NB698  (50-319273-00)	NC006  (50-319161-00) NB697  (50-306704-00) NB698  (50-319273-00)	NB575 [2] 	 AY840, AY850, AY860  JN693  JN777  AY900, AY910, AY920  JH5005  BK480  BL010, BL020, BL030  JH5058  BP800  JJ120  BP810  JJ200  BS260  JJ385  BY330, BY340, BY350  JC281  JC282  JC283  JC436  JC437  JC756  JC824  JD303  JD304  JD474  JE119  JE120  JN453 JN626
HBS036  (22-29001B) M12x1.5x102mm (x10)	JD303  JD304   JE5029 (31-027779-00)	JN777 (50-027776-00)	JH5058 (31-027781-00)	PA658 (x8) (50-319265-00)	NJ449  (50-319266-00) NJ449  (50-319266-00) NK103  (87x100x8.5mm, FPM)			
HBS003  (22-29009B) M11x1.25x140mm (x10)	JC283  (31-025183-10) JC282  (31-024625-20)  JE120 (31-024767-00)	JN453 [127] (31-024572-00)	JJ200 (31-025011-00)	HR343  (24-30602-50/0)	NC006  (50-319161-00) NB700  (50-306551-50) NB701  (86x104x11mm, FPM) →12/85 NB806  (90x104x11mm, FPM) (50-306552-00) 01/86 →	NB575 [2] 		
HBS074  (22-29100B) M11x1.25x154mm (x10)	JC436  (31-028012-00) JD474  JC437  (31-024854-10)  JE119 (31-024520-00)	JN453 [127] (31-024572-00) →12/85 JN693 [128] (31-026198-10) 01/86 →	JJ200 (31-025011-00)	HR343  (24-30602-50/0)	NC006  (50-319161-00) NB734  (35x50x8mm, FPM) NB701  (86x104x11mm, FPM) (50-306261-50) →12/85 NB806  (90x104x11mm, FPM) (50-306552-00) 01/86 →	NB575 [2] 		
HBS002  (22-29098B) M10x1.25x140mm (x10)	JC824  (31-026334-00) JC281  (31-024312-10)  JE120 (31-024767-00)	JN626 (31-026099-10)	JH5005 (x2) [116] (31-027194-00) JJ120 (x2)	PA565 (x8) (50-305900-50) HR342  (24-30590-05/0)	NC006  (50-319161-00) NB697  (50-306704-00) NB698  (80x98x10mm, FPM) (50-319273-00)	NB575 [2]  Ch.h		
HBS074  (22-29100B) M11x1.25x154mm (x10)	JD474  JC437  (31-024854-10)  JE119 (31-024520-00)	JN693 [128] (31-026198-10)	JJ200 (31-025011-00)	HR343  (24-30602-50/0)	NC006  (50-319161-00) NB734  (35x50x8mm, FPM) NB806  (90x104x11mm, FPM) (50-306552-00)	NA5271 [70] NB575 [2] 		
HBS003  (22-29009B) M11x1.25x140mm (x10)	JC756  (31-025820-20) JC282  (31-024625-20)  JE120 (31-024767-00)	JN693 [128] (31-026198-10)	JJ385 [148] (50-026131-00)	PA565 (x8) (50-305900-50) HR342  (24-30590-05/0)	NC006  (50-319161-00) NB700  (31x50x8mm, FPM) (50-306551-50) NB806  (90x104x11mm, FPM) (50-306552-00)	NB575 [2]  NB807 [2] 		



KW/PS



Belmont 1.8L i				09/85 → 08/91		82	BM380 (Fibre) (30-024765-10) → Eng.14360690 BP810 (Fibre) (30-025818-10) Eng.14360691 →	DM381 (21-24765-23/0) → Eng.14360690 DP811 (21-25818-23/0) Eng.14360691 →	EK482 (22-26131-01/0) Eng.14360691 →
18 SE	1796	4	84.80	Injection, SOHC	82/111				
18 E	1796	4	84.80	Injection, SOHC	85/115				
Brava 2.2L D Diesel				08/91 → 09/96		83	BM370 (Fibre) (30-028348-00) BR200 (Steel)	DM370 ○ (21-28348-21/0)	GM370 ○
C223	2238	4	88.00		39-54/ 53-73				
Brava 2.2L D 4x4 Diesel				08/91 → 09/96		84	BM370 (Fibre) (30-028348-00) BR200 (Steel)	DM370 ○ (21-28348-21/0)	GM372 ■
C223	2238	4	88.00		39-54/ 53-73				
Brava 2.3L				08/91 → 08/94		85	BP920 (Graphite) (30-028321-00)	DP920 (21-28321-20/0)	GP920
4 ZD1	2255	4	89.50		69-72/ 94-98				
Brava 2.3L 4x4				06/90 → 08/94		86	BP920 (Graphite) (30-028321-00)	DP920 (21-28321-20/0)	GP921
4 ZD1	2255	4	89.50		69-72/ 94-98				
Brava 2.5L D Diesel				08/91 → 06/94		87	BR990 (MLS)	DR990	GR990
Brava 2.5L D 4x4 Diesel				06/90 → 06/94					
Brava 2.5L TD Diesel				07/94 →					
Brava 2.5L TD 4x4 Diesel				07/94 →					
4 JAT1	2499	4	93.00	Direct Injection, OHV	56/76				
4 JA1	2499	4	93.00	Direct Injection, OHV	56-74/ 76-101				
Calibra Coupe 2.0L i				06/90 → 07/97		88	BP820 (Fibre) (30-025819-10)	DP820 (21-25819-21/0)	EK482 (22-26131-01/0)
Calibra Coupe 2.0L i 4x4				06/90 → 07/97					
C 20 NE	1998	4	86.00	Injection, SOHC	85/115				
Calibra Coupe 2.0L i 16V				06/90 → 07/97		89	BY250 (Fibre) (30-027987-10)	DY250 (21-27987-20/0)	EC130 (22-28793-00/0) HC5007 [212] (22-28386-00/0)
Calibra Coupe 2.0L i 16V 4x4				02/94 → 07/97					
X 20 XEV	1998	4	86.00	Injection, DOHC	100/136				
Calibra Coupe 2.0L i 16V				06/90 → 02/94		90	BS720 (Fibre) (30-026310-10)	DS720 (21-26310-22/0)	ES720 (22-27206-00/0)
Calibra Coupe 2.0L i 16V 4x4				06/90 → 02/94					
C 20 XE	1998	4	86.00	Injection, DOHC	110/150				
Calibra Coupe 2.0L i Turbo 4x4				03/92 → 07/97		91	BY260 (Fibre) (30-027427-00)	DY260 (21-27427-21/0)	ES720 (22-27206-00/0)
C 20 LET	1998	4	86.00	Injection, DOHC	150/204				

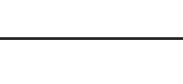









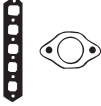

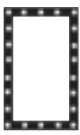

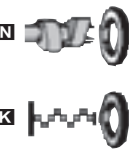













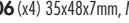
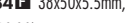
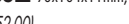

















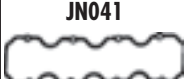





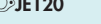

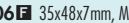
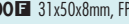
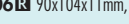



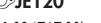

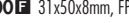
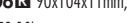



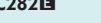
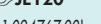

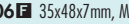
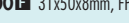
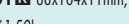
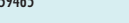

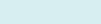
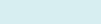
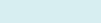

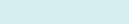
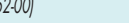
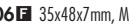

								
HBS003 ⊕ (22-29009B) M11x1.25x140mm (x10)	JC283 ■ (31-025183-10) →Eng.14360690 JC756 ■ (31-025820-20) Eng.14360691→ JC282 ■ (31-024625-20)	JN453 [127] (31-024572-00) →Eng.14360690 JN693 [128] (31-026198-10) Eng.14360691→	JJ200 (31-025011-00) →Eng.14360690 JJ385 [148] (50-026131-00) Eng.14360691→	PA565 (x8) (50-305900-50) Eng.14360691→ HR343 ■ (24-30602-50/0) →Eng.14360690 HR342 ■ (24-30590-05/0) Eng.14360691→	NC006 ■ 35x48x7mm, MVQ (50-319161-00) NB700 ■ 31x50x8mm, FPM (50-306551-50) NB701 ■ 86x104x11mm, FPM (50-306261-50) →Eng.14360690 NB806 ■ 90x104x11mm, FPM (50-306552-00) Eng.14360691→	NB575 [2]■ NB807 [2]■		 BM370  JN408  BM380  JN453  BP810  JN634  BP820  JN693  BP920  JN707  BR200  JP016  BR990  JJ192  BS720  JJ200  BY250  JJ358  BY260  JC282  JC283  JJ385  JC643  JJ459  JC683  JJ470  JC684  JJ615  JD430  JJ616  JD451  JD455  JD456  JE120  JM950  JJ617
HBS286 ⊕ (22-20006B) M11x1.50x117mm (x3) M11x1.50x116mm (x16)	JC643 ■ ⊕JE019	JN408	JH016		NJ267 42x55x9mm, NBR NJ266 ■ 65x84x9mm, NBR NJ265 ■ 82x105x13mm, MVQ			 BR200  JP016
HBS286 ⊕ (22-20006B) M11x1.50x117mm (x3) M11x1.50x116mm (x16)	JC643 ■ ⊕JE019	JN408	JJ192		NJ267 42x55x9mm, NBR NJ266 ■ 65x84x9mm, NBR NJ265 ■ 82x105x13mm, MVQ			 BR990  JJ192
	JC684 ■ JC683 ■	JN634 (50-028320-00) HL532 ■	JJ358	PA933 ■ (x8)	NJ454 30x45x8mm, NBR NJ323 ■ 40x56x7mm, NBR NJ322 ■ 95x118x10mm, NBR			 BS720  JJ200
	JC684 ■ JC683 ■	JN634 (50-028320-00) HL532 ■	JJ358	PA933 ■ (x8)	NJ454 30x45x8mm, NBR NJ323 ■ 40x56x7mm, NBR NJ322 ■ 95x118x10mm, NBR			 BY250  JJ358
		JN707	JJ470	PA418 (x8)	NJ322 ■ 95x118x10mm, NBR			 BY260  JC282  JC283  JJ385
HBS003 ⊕ (22-29009B) M11x1.25x140mm (x10)	JC756 ■ (31-025820-20) JC282 ■ (31-024625-20) ⊕JE120 (31-024767-00)	JN693 [128] (31-026198-10)	JJ385 (x2) [148] (50-026131-00)	PA565 (x8) (50-305900-50) HR342 ■ (24-30590-05/0)	NC006 ■ 35x48x7mm, MVQ (50-319161-00) NB700 ■ 31x50x8mm, FPM (50-306551-50) NB806 ■ 90x104x11mm, FPM (50-306552-00)	NB575 [2]■ NB807 [2]■		 JC643  JC683  JJ470
HBS054 ⊕ (22-29013B) M11x1.25x105mm (x10)	JD451 ■ (31-027699-00) JD450 ■ (31-027684-00) ⊕JE120 (31-024767-00)	JP016 (50-027683-00)	JJ615 (31-028793-00) JJ616 ■ [212] (31-028386-00) JJ617 ■ [212] (31-028385-00)	HR791 ■ 24-30614-76/0	NC006 ■ (x2) 35x48x7mm, MVQ (50-319161-00) NB700 ■ 31x50x8mm, FPM (50-306551-50) NB806 ■ 90x104x11mm, FPM (50-306552-00)			 JC684  JJ615  JD430  JJ616
HBS035 ⊕ (22-29005B) M11x1.25x110mm (x10) →Eng.14137011 HBS054 ⊕ (22-29013B) M11x1.25x105mm (x10) Eng.14137012→	JD455 ■ (31-026335-10) JD430 ■ (31-025888-00)	JM950 (50-026336-10)	JJ459 (x2) [148] (31-027206-00)	PA565 (x16) (50-305900-50) HR342 ■ (x2) (24-30590-05/0)	NC006 ■ (x2) 35x48x7mm, MVQ (50-319161-00) NB884 ■ 38x50x5.5mm, FPM (50-319010-00) NB806 ■ 90x104x11mm, FPM (50-306552-00)	NB575 [2]■		 JD455  JD456  JE120
HBS035 ⊕ (22-29005B) M11x1.25x110mm (x10) →Eng.14003804 HBS054 ⊕ (22-29013B) M11x1.25x105mm (x10) Eng.14003805→	JD455 ■ (31-026335-10) JD456 ■ (31-027459-00)	JM950 (50-026336-10)	JJ459 (x2) [148] (31-027206-00)	PA565 (x16) (50-305900-50) HR342 ■ (x2) (24-30590-05/0)	NC006 ■ (x2) 35x48x7mm, MVQ (50-319161-00) NB884 ■ 38x50x5.5mm, FPM (50-319010-00) NB806 ■ 90x104x11mm, FPM (50-306552-00)	NB807 [2]■		 JM950

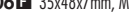
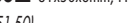

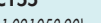
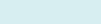
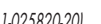
KW/PS

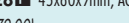

Calibra Coupe 2.5L i V6				04/93 → 07/97		92	BY270 (Fibre) (x2) (30-027690-00)	DY270 (21-27690-20/0) C25XE DY271 (21-27690-21/0) X25XE	EY300 X25XE
C 25 XE	2498	6	81.60	Injection, DOHC, V6		125/170			
X 25 XE	2498	6	81.60	Injection, DOHC, V6		125- 143/ 170- 194			
Carlton 1.8L				09/87 → 03/94		93	BP810 (Fibre) (30-025818-10)	DP810 (21-25818-22/0)	EK482 (22-26131-01/0)
Carlton 1.8L N				09/86 → 08/87					
18 NV	1796	4	84.80	Carburettor, SOHC		60/81			
E 18 NVR	1796	4	84.80	Carburettor, SOHC		65/88			
Carlton 1.8L i				09/86 → 03/94		94	BP810 (Fibre) (30-025818-10)	DP811 (21-25818-23/0)	EK482 (22-26131-01/0)
18 SEH	1796	4	84.80	Injection, SOHC		85/115			
Carlton 1.8L S				11/82 → 08/86		95	BM380 (Fibre) (30-024765-10)	DM380	EK482 (22-26131-01/0) 01/86 → Eng.14159466 →
18 S	1796	4	84.80	SOHC		66/89			
Carlton 1.8L S				09/86 → 03/94		96	BP810 (Fibre) (30-025818-10)	DP810 (21-25818-22/0)	EK482 (22-26131-01/0)
18 SV	1796	4	84.80	Carburettor, SOHC		66/89			
Carlton 2.0L				01/78 → 12/86		97	BJ170 (Fibre) (30-025662-10)		
20 S	1979	4	95.00	Carburettor, CIH		74/100			
Carlton 2.0L				01/86 →		98	BP820 (Fibre) (30-025819-10)	DP820 (21-25819-21/0)	EK482 (22-26131-01/0)
20 SER	1998	4	86.00	Injection		90/122			









								
HBS164  (22-29011B) M11x1.25x105mm (x16)	JD5202  (x2) (50-027980-00) X25XE JD5201  (31-027700-00) C25XE JD458  (31-027688-00) C25XE JD5203  (x3) (50-027979-00) X25XE JD457  (x2) (31-027686-00) C25XE JD459  (x2) (31-027698-00)	JM5095  (50-027697-00) JM5094  (50-027696-00) HM5294  (24-27696-00/0)	JH5052 (31-027689-00) C25XE JJ573  (50-027851-00) X25XE JJ572  (50-027852-00) X25XE	HR5062  24-30614-73/0	NC006  (x4) 35x48x7mm, MVQ (50-319161-00) NB884  38x50x5.5mm, FPM (50-319010-00) NB806  90x104x11mm, FPM (50-306552-00)			 BM380  BP810  BP820  BY270  JC155  JC282  JC283  JC756  JC757  JD457  JD458  JD459  JD5201  JD5202  JD5203  JE120  JM5094  JM5095  JN041  JN453  JN693
HBS003  (22-29009B) M11x1.25x140mm (x10)	JC757  (31-025817-10) JC282  (31-024625-20)  JE120 (31-024767-00)	JN693 [128] (31-026198-10)	JJ385 (x2) [148] (50-026131-00)	PA565 (x8) (50-305900-50) HR342  (24-30590-05/0)	NC006  35x48x7mm, MVQ (50-319161-00) NB700  31x50x8mm, FPM (50-306551-50) NB806  90x104x11mm, FPM (50-306552-00)			NB807 [2] 
HBS003  (22-29009B) M11x1.25x140mm (x10)	JC756  (31-025820-20) JC282  (31-024625-20)  JE120 (31-024767-00)	JN693 [128] (31-026198-10)	JJ385 (x2) [148] (50-026131-00)	PA565 (x8) (50-305900-50) HR342  (24-30590-05/0)	NC006  35x48x7mm, MVQ (50-319161-00) NB700  31x50x8mm, FPM (50-306551-50) NB806  90x104x11mm, FPM (50-306552-00)			NB807 [2] 
HBS003  (22-29009B) M11x1.25x140mm (x10)	JC283  (31-025183-10) JC282  (31-024625-20)  JE120 (31-024767-00)	JN453 [127] (31-024572-00)	JJ200 (31-025011-00)	HR343  (24-30602-50/0)	NC006  35x48x7mm, MVQ (50-319161-00) NB700  31x50x8mm, FPM (50-306551-50) NB701  86x104x11mm, FPM (50-306261-50) →12/85 →Eng.14159465 NB806  90x104x11mm, FPM (50-306552-00) 01/86 → Eng.14159466 →			NB575 [2] 
HBS003  (22-29009B) M11x1.25x140mm (x10)	JC757  (31-025817-10) JC282  (31-024625-20)  JE120 (31-024767-00)	JN693 [128] (31-026198-10)	JJ385 [148] (50-026131-00)	PA565 (x8) (50-305900-50) HR342  (24-30590-05/0)	NC006  35x48x7mm, MVQ (50-319161-00) NB700  31x50x8mm, FPM (50-306551-50) NB806  90x104x11mm, FPM (50-306552-00)			NB575 [2] 
HBS161  (22-29007B) M12x1.50x64mm (x5) M12x1.50x97.5mm (x5)	JC155 (31-021058-20)	JN041 (31-022926-10)	HC417  (23-21237-01/0)		NB628  45x60x9mm, ACM (50-305272-00) NB469  77x100x11.5mm, FPM (50-306260-50)			NB575 [2] 
HBS003  (22-29009B) M11x1.25x140mm (x10)	JC756  (31-025820-20) JC282  (31-024625-20)  JE120 (31-024767-00)	JN693 [128] (31-026198-10)	JJ385 [148] (50-026131-00)	PA565 (x8) (50-305900-50) HR342  (24-30590-05/0)	NC006  35x48x7mm, MVQ (50-319161-00) NB700  31x50x8mm, FPM (50-306551-50) NB806  90x104x11mm, FPM (50-306552-00)			NB575 [2]  NB807 [2] 

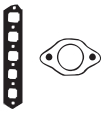

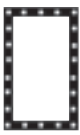
KW/PS

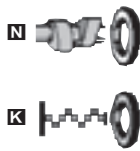

Carlton 2.0L 09/90 → 03/94 99						BP820 (Fibre) (30-025819-10)	DP820 (21-25819-21/0)	EK482 (22-26131-01/0)		
Carlton 2.0L i 09/90 → 03/94										
Carlton 2.0L S 10/78 → 08/86										
C 20 NEJ	1998	4	86.00	DOHC	73-74/ 99-100					
C 20 NEF	1998	4	86.00		74/100					
Carlton 2.0L 09/86 → 03/94 100						BP820 (Fibre) (30-025819-10)	DP820 (21-25819-21/0)	EK482 (22-26131-01/0)		
Carlton 2.0L i 09/86 → 03/94										
C 20 NE	1998	4	86.00	Injection, SOHC	85/115					
20 SE	1998	4	86.00	Injection, SOHC	90/122					
Carlton 2.0L i 01/83 → 12/84 101						BJ170 (Fibre) (30-025662-10)				
20 E	1979	4	95.00	Injection, CIH	81/110					
Carlton 2.2L i 11/84 → 08/86 102						BJ170 (Fibre) (30-025662-10)				
22 E	2197	4	95.00	Injection, CIH	85/116					
Carlton 2.3L D Diesel 05/83 → 08/86 103						BR010 (Fibre), 1.30mm, 1 Hole (30-025657-10) BR020 (Fibre), 1.40mm, 2 Holes (30-025658-10) BR030 (Fibre), 1.50mm, 3 Holes (30-025659-10)	DR012 ▲■ (21-24240-23/0)	EJ161		
23 D	2260	4	92.00	Indirect Injection, SOHC	48-52/ 65-71					
Carlton 2.3L D Diesel 09/86 → 03/94 104										
23 YD	2260	4	92.00	SOHC	54/73					
Carlton 2.3L TD Diesel 09/86 → 08/88 105						BR010 (Fibre), 1.30mm, 1 Hole (30-025657-10) BR020 (Fibre), 1.40mm, 2 Holes (30-025658-10) BR030 (Fibre), 1.50mm, 3 Holes (30-025659-10)	DR010 ▲ (21-23007-23/0)	EJ161		
Carlton 2.3L TD Interc. Diesel 08/88 → 03/94										
Carlton 2.3L TD US Diesel 09/86 → 08/88										
23 YDT	2260	4	92.00	SOHC, Turbo	66/89					
23 YDT	2260	4	92.00	SOHC	66/89					
23 DTR	2260	4	92.00	Indirect Injection, SOHC	74/100					
Carlton 2.4L i 09/88 → 03/94 106						BJ170 (Fibre) (30-025662-10)				
C 24 NE	2410	4	95.00	Injection, SOHC	92/125					
Carlton 2.6L i 09/90 → 03/94 107						BT530 (Fibre) (30-026239-10)				
C 26 NE	2594	6	88.80	Injection, SOHC	110/150					
Carlton 3.0L 24V 09/89 → 03/94 108						BV950 (Fibre) (30-027397-00)	DV951	EB950 (22-27392-00/0)		
Carlton 3.0L 3000 24V 09/89 → 03/94										
C 30 SEJ	2969	6	95.00	Injection, DOHC	147/200					
C 30 SE	2969	6	95.00	Injection, DOHC	150/204					
Cavalier 1.3L N 09/81 → 08/88 109						BK470 (Fibre) (30-024033-10)	DK470 (21-24033-26/0) → 12/85 DK471 (21-24033-30/0) 01/86 →	EK470 (22-27194-05/0)		
Cavalier 1.3L S 09/81 → 08/88										
13 N	1297	4	75.00	Carburettor, SOHC	39-44/ 53-60					
13 S	1297	4	75.00	Carburettor, SOHC	42-55/ 57-75					











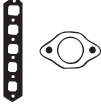

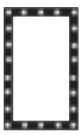

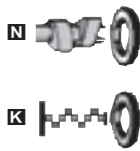









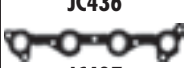

									
HBS003 (22-29009B) M11x1.25x140mm (x10)	JC756 (31-025820-20) JC282E (31-024625-20)	JN693 [128] (31-026198-10)	JJ385 [148] (50-026131-00)	PA565 (x8) (50-305900-50) HR342E (24-30590-05/0)	NC006E 35x48x7mm, MVQ (50-319161-00) NB700E 31x50x8mm, FPM (50-306551-50) NB806E 90x104x11mm, FPM (50-306552-00)	NB575 [2] NB807 [2]		BK470 BP820 BR010, BR020, BR030 BT530 BV950 JC155 JC280 JC281 JC282 JC756 JD187 JE119 JE120	JN924 HC295 HC417 JH5005 JH5019 JJ120 JJ385
HBS003 (22-29009B) M11x1.25x140mm (x10)	JC756 (31-025820-20) JC282E (31-024625-20) JE120 (31-024767-00)	JN693 [128] (31-026198-10)	JJ385 (x2) [148] (50-026131-00)	PA565 (x8) (50-305900-50) HR342E (24-30590-05/0)	NC006E 35x48x7mm, MVQ (50-319161-00) NB700E 31x50x8mm, FPM (50-306551-50) NB806E 90x104x11mm, FPM (50-306552-00)	NB575 [2] NB807 [2]		BR010, BR020, BR030 BT530 BV950 JC155 JC280 JC281 JC282 JC756 JD187 JE119 JE120	JN924 HC295 HC417 JH5005 JH5019 JJ120 JJ385
HBS161 (22-29007B) M12x1.50x64mm (x5) M12x1.50x97.5mm (x5)	JC155 (31-021058-20)	JN041 (31-022926-10)	HC417E (23-21237-01/0)	HR336E (24-30656-05/0)	NB628E 45x60x9mm, ACM (50-305272-00) NB469E 77x100x11.5mm, FPM (50-306260-50)	NB575 [2]		JC280 JC281 JC282 JC756 JD187 JE119 JE120	JJ120 JJ385
HBS161 (22-29007B) M12x1.50x64mm (x5) M12x1.50x97.5mm (x5)		JN041 (31-022926-10)	HC417E (23-21237-01/0)		NB628E 45x60x9mm, ACM (50-305272-00) NB469E 77x100x11.5mm, FPM (50-306260-50)	NB575 [2]		JC280 JC281 JC282 JC756 JD187 JE119 JE120	JJ120 JJ385
HBS160 (22-29004B) M13x1.50x134mm (x10)		JN523E JN521E (31-023007-10)	HC417E (23-21237-01/0)	PA543 (x8) (50-305908-10) HR794E (24-30590-81/0)	NB628E 45x60x9mm, ACM (50-305272-00) NB690E 81x100.1x11.5mm, FPM (50-319087-00)	NB575 [2]		JC756 JD187 JE119 JE120	
HBS160 (22-29004B) M13x1.50x134mm (x10)		JN523E JN521E (31-023007-10)	HC417E (23-21237-01/0)	PA543 (x8) (50-305908-10) HR794E (24-30590-81/0)	NB628E 45x60x9mm, ACM (50-305272-00) NB690E 81x100.1x11.5mm, FPM (50-319087-00)			JC756 JD187 JE119 JE120	
HBS163 (22-29010B) M13x1.50x134mm (x10)	JD5765 (31-025415-10)	JN523E JN521E (31-023007-10)	HC417E (23-21237-01/0)	PA543 (x8) (50-305908-10) HR794E (24-30590-81/0)	NB628E 45x60x9mm, ACM (50-305272-00) NB690E 81x100.1x11.5mm, FPM (50-319087-00)			JN041 JN344 JN521 JN523 JN626 JN693 JN694 JN923	
HBS161 (22-29007B) M12x1.50x64mm (x5) M12x1.50x97.5mm (x5)	JD187 (31-026476-10)	JN923 (50-026499-00) JN924 (x2)	JH5019E (50-026493-00)	HR336E (x2) (24-30656-05/0)	NB628E 45x60x9mm, ACM (50-305272-00) NB469E 77x100x11.5mm, FPM (50-306260-50)			JN041 JN344 JN521 JN523 JN626 JN693 JN694 JN923	
		JN694 (50-026098-00)	HC295E (23-21243-01/0) HC5008E	HR336E (x3) (24-30656-05/0)	NB628E 45x60x9mm, ACM (50-305272-00) NB469E 77x100x11.5mm, FPM (50-306260-50)			JN041 JN344 JN521 JN523 JN626 JN693 JN694 JN923	
HBS417 (22-29026B) M12x1.50x88mm (x14)			JJ508 (50-027392-00)	PA565 (x24) (50-305900-50) HR342E (x3) (24-30590-05/0)				JN041 JN344 JN521 JN523 JN626 JN693 JN694 JN923	
HBS002 (22-29098B) M10x1.25x140mm (x10)	JC280E (31-024313-10) JC281E (31-024312-10) JE119 (31-024520-00)	JN344 (31-024299-00) →12/85 JN626 (31-026099-10) 01/86 →	JH5005 [116] (31-027194-00) JJ120	PA565 (x8) (50-305900-50) HR342E (24-30590-05/0)	NC006E 35x48x7mm, MVQ (50-319161-00) NB697E 26x42x8mm, FPM (50-306704-00) NB698E 80x98x10mm, FPM (50-319273-00)	NB575 [2]		JN041 JN344 JN521 JN523 JN626 JN693 JN694 JN923	



KW/PS



Cavalier 1.4L S		09/88 → 11/95		110		BS260 (Fibre) (30-026329-10)	DS260 (21-26329-21/0)	EK470 (22-27194-05/0)
14 NV	1389	4	77.60	Carburettor, SOHC	53-55/ 72-75			
Cavalier 1.6L		10/83 → 08/88		111		BK480 (Fibre) (30-024578-10)	DK480 (21-24578-22/0)	
Cavalier 1.6L S		09/81 → 08/88						
16 SH	1598	4	80.00	Carburettor, SOHC	66/89			
Cavalier 1.6L		09/88 → 05/93		112		BP800 (Fibre) (30-025706-20)	DP800 (21-25706-26/0)	EK484 [129] (22-27194-01/0)
16 SV	1598	4	79.00	Carburettor, SOHC	60/82			
Cavalier 1.6L D Diesel		03/82 → 08/88		113		BLO10 (Fibre), 1.40mm (30-025124-10) →0.75mm BLO20 (Fibre), 1.50mm, 1 Notch (30-025125-10) →0.75 → 0.85mm BLO30 (Fibre), 1.60mm, 2 Notches (30-025126-10) →0.85mm →	DLO10▲ (25-24572-02/0) →12/85 DLO11▲ (21-26198-20/0) 01/86 →	EK481 (22-25011-00/0) →12/85 EK485 (22-25011-04/0) 01/86 →
16 D	1598	4	80.00	Indirect Injection, SOHC	40/54			
16 DA	1598	4	80.00	Direct Injection, SOHC	40/54			
Cavalier 1.6L i		08/86 → 11/95		114		BP800 (Fibre) (30-025706-20)	DP802 (21-25706-25/0)	EK484 [129] (22-27194-01/0)
C 16 NZ/E 16 NZ	1598	4	79.00	SPi, SOHC	55/75			
C 16 LZ	1598	4	80.00		55/75			
Cavalier 1.6L i		09/93 → 11/95		115		BP800 (Fibre) (30-025706-20)	DP802 (21-25706-25/0)	ES260 [248] (22-27194-00/0)
X 16 SZ	1598	4	79.00	SPi, SOHC	52/71			
Cavalier 1.6L N		09/81 → 08/88		116		BK480 (Fibre) (30-024578-10)	DK480 (21-24578-22/0)	
16 N	1598	4	80.00	Direct Injection, DOHC	55/75			
Cavalier 1.7L D Diesel		07/92 → 11/95		117		BY330 (Fibre), 1.30mm (30-027492-10) BY340 (Fibre), 1.40mm, 1 Notch (30-027493-10) BY350 (Fibre), 1.50mm, 2 Notches (30-027494-10)	DLO11▲ (21-26198-20/0)	EK485 (22-25011-04/0)
17 DR	1699	4	82.50	Indirect Injection, SOHC	44/ 57-60			
Cavalier 1.7L D Diesel		09/88 → 09/92		118		BY330 (Fibre), 1.30mm (30-027492-10) BY340 (Fibre), 1.40mm, 1 Notch (30-027493-10) BY350 (Fibre), 1.50mm, 2 Notches (30-027494-10)	DLO11▲ (21-26198-20/0)	EK485 (22-25011-04/0)
17 D	1699	4	82.50	Indirect Injection, SOHC	42/57			







								
HBS002 Ⓢ (22-29098B) M10x1.25x140mm (x10)	JC824 ■ (31-026334-00) JC281 ■ (31-024312-10)	JN626 (31-026099-10)	JH5005 [116] (31-027194-00) JJ120	PA565 (x8) (50-305900-50) HR342 ■ (24-305900-05/0)	NC006 ■ 35x48x7mm, MVQ (50-319161-00) NB697 ■ 26x42x8mm, FPM (50-306704-00) NB698 ■ 80x98x10mm, FPM (50-319273-00)	NB575 [2]■		 BK480  BL010, BL020, BL030  BP800  BS260  BY330, BY340, BY350  JC281  JC282  JC283  JC436  JC437  JC824  JD474  JE119  JE120  JN453  JN626  JN693  JH5005  JJ120  JJ200
HBS003 Ⓢ (22-29009B) M11x1.25x140mm (x10)	JC283 ■ (31-025183-10) JC282 ■ (31-024625-20) Ⓢ JE120 (31-024767-00)	JN453 [127] (31-024572-00)	JJ200 (31-025011-00)	HR343 ■ (24-30602-50/0)	NC006 ■ 35x48x7mm, MVQ (50-319161-00) NB700 ■ 31x50x8mm, FPM (50-306551-50) NB701 ■ 86x104x11mm, FPM (50-306261-50) →12/85 NB806 ■ 90x104x11mm, FPM (50-306552-00) 01/86→	NB575 [2]■		
HBS002 Ⓢ (22-29098B) M10x1.25x140mm (x10)	JC824 ■ (31-026334-00) JC281 ■ (31-024312-10) Ⓢ JE120 (31-024767-00)	JN626 (31-026099-10)	JH5005 (x2) [116] (31-027194-00) JJ120 (x2)	PA565 (x8) (50-305900-50) HR342 ■ (24-305900-05/0)	NC006 ■ 35x48x7mm, MVQ (50-319161-00) NB697 ■ 26x42x8mm, FPM (50-306704-00) NB698 ■ 80x98x10mm, FPM (50-319273-00)	NB575 [2]■		
HBS074 Ⓢ (22-29100B) M11x1.25x154mm (x10)	JC436 ■ (31-028012-00) JC437 ■ (31-024854-10) Ⓢ JE119 (31-024520-00)	JN453 [127] (31-024572-00) →12/85 JN693 [128] (31-026198-10) 01/86→	JJ200 (31-025011-00)	HR343 ■ (24-30602-50/0)	NC006 ■ 35x48x7mm, MVQ (50-319161-00) NB734 ■ 35x50x8mm, FPM NB701 ■ 86x104x11mm, FPM (50-306261-50) →12/85 NB806 ■ 90x104x11mm, FPM (50-306552-00) 01/86→	NB575 [2]■		
HBS002 Ⓢ (22-29098B) M10x1.25x140mm (x10)	JC824 ■ (31-026334-00) JC281 ■ (31-024312-10)	JN626 (31-026099-10)	JH5005 (x2) [116] (31-027194-00) JJ120 (x2)	PA565 (x8) (50-305900-50) HR342 ■ (24-305900-05/0)	NC006 ■ 35x48x7mm, MVQ (50-319161-00) NB697 ■ 26x42x8mm, FPM (50-306704-00) NB698 ■ 80x98x10mm, FPM (50-319273-00)	NB575 [2]■		
HBS002 Ⓢ (22-29098B) M10x1.25x140mm (x10)	JC824 ■ (31-026334-00) JC281 ■ (31-024312-10)	JN626 (31-026099-10)	JH5005 [116] (31-027194-00)	PA565 (x8) (50-305900-50) HR342 ■ (24-305900-05/0)	NC006 ■ 35x48x7mm, MVQ (50-319161-00) NB697 ■ 26x42x8mm, FPM (50-306704-00) NB698 ■ 80x98x10mm, FPM (50-319273-00)	NB575 [2]■		
HBS003 Ⓢ (22-29009B) M11x1.25x140mm (x10)	JC283 ■ (31-025183-10) JC282 ■ (31-024625-20) Ⓢ JE120 (31-024767-00)	JN453 [127] (31-024572-00)	JJ200 (31-025011-00)	HR343 ■ (24-30602-50/0)	NC006 ■ 35x48x7mm, MVQ (50-319161-00) NB700 ■ 31x50x8mm, FPM (50-306551-50) NB701 ■ 86x104x11mm, FPM (50-306261-50)	NB575 [2]■		
HBS074 Ⓢ (22-29100B) M11x1.25x154mm (x10)	JD474 ■ JC437 ■ (31-024854-10) Ⓢ JE119 (31-024520-00)	JN693 [128] (31-026198-10)	JJ200 (31-025011-00)	HR343 ■ (24-30602-50/0)	NC006 ■ 35x48x7mm, MVQ (50-319161-00) NB734 ■ 35x50x8mm, FPM NB806 ■ 90x104x11mm, FPM (50-306552-00)	NB575 [2]■		
HBS074 Ⓢ (22-29100B) M11x1.25x154mm (x10)	JD474 ■ JC437 ■ (31-024854-10) Ⓢ JE119 (31-024520-00)	JN693 [128] (31-026198-10)	JJ200 (31-025011-00)	HR343 ■ (24-30602-50/0)	NC006 ■ 35x48x7mm, MVQ (50-319161-00) NB734 ■ 35x50x8mm, FPM NB806 ■ 90x104x11mm, FPM (50-306552-00)	NA5271 [70] NB575 [2]■		

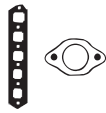

KW/PS

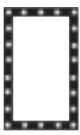

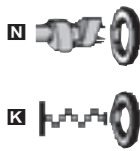
Cavalier 1.7L TD Diesel					09/88 → 11/95	119	AB5010 (MLS), 1.40mm (30-029163-00) AB5020 (MLS), 1.45mm, 1 Hole (30-029164-00) AB5030 (MLS), 1.50mm, 2 Holes (30-029165-00)	CY811 ▲ ■ (21-27776-22/0)	FY811 ▲ (20-27776-02/0)
17 DT (TC4EE1)	1686	4	79.00			60/81			
Cavalier 1.8L					08/86 → 10/92	120	BP810 (Fibre) (30-025818-10)	DP810 (21-25818-22/0)	EK482 (22-26131-01/0)
Cavalier 1.8L i					03/90 → 11/95				
E 18 NV	1796	4	84.80	Carburettor, SOHC		62/84			
18 SV	1796	4	84.80	Carburettor, SOHC		66/89			
C 18 NZ	1796	4	84.80	SPi, SOHC		66/89			
Cavalier 1.8L i					09/81 → 08/88	121	BP810 (Fibre) (30-025818-10)	DP811 (21-25818-23/0)	EK482 (22-26131-01/0) 01/86 →
18 SE	1796	4	84.80	Injection, SOHC		82/111			
Cavalier 1.8L i					09/81 → 08/88	122	BM380 (Fibre) (30-024765-10)	DM381 (21-24765-23/0)	
18 SE	1796	4	84.80	Injection, SOHC		82/111			
18 E	1796	4	84.80	Injection, SOHC		85/115			
Cavalier 1.8L i					01/85 → 08/86	123	BP810 (Fibre) (30-025818-10)	DP810 (21-25818-22/0)	EK482 (22-26131-01/0)
C 18 NE	1796	4	84.80			74/100			
Cavalier Convertible 1.8L i					03/85 → 10/88	124	BP810 (Fibre) (30-025818-10)	DP811 (21-25818-23/0)	EK482 (22-26131-01/0)
18 SE	1796	4	84.80	Injection, SOHC		82/111			
Cavalier 1.8 i 4x4					01/91 → 10/92	125	BP820 (Fibre) (30-025819-10)	DP820 (21-25819-21/0)	EK482 (22-26131-01/0)
Cavalier 2.0L i					09/86 → 11/95				
Cavalier 2.0L i 4x4					09/88 → 10/92				
Cavalier 2.0L SRi					09/88 → 09/92				
Cavalier 2.0L SRi 130					03/87 → 08/88				
C 20 NE	1998	4	86.00	Injection, SOHC		85/115			
20 NE	1998	4	86.00	Injection, SOHC		85/116			
20 SEH	1998	4	86.00	Injection, SOHC		95/129			
Cavalier 2.0L i					09/86 → 08/88	126	BP820 (Fibre) (30-025819-10)	DP820 (21-25819-21/0)	EK482 (22-26131-01/0)
20 SE	1998	4	86.00	Injection, SOHC		90/122			

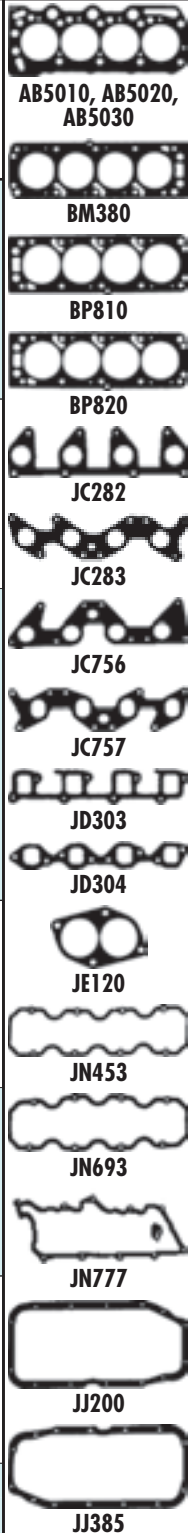





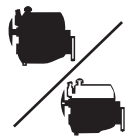



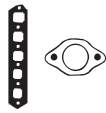

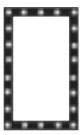

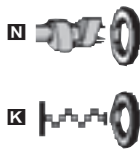











































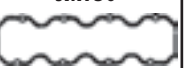

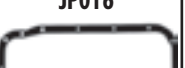





















































































								
HBS036 ® (22-29001B) M12x1.5x102mm (x10)	JD303 ■ JD304 ■ ☉ JE5029 (31-027779-00)	JN777 (50-027776-00)		PA658 (x8) (50-319265-00)	NJ449 40x52x6mm, NBR (50-319266-00) NC004 (50-319268-00) NJ449 40x52x6mm, NBR (50-319266-00) NK103 87x100x8.5mm, FPM			AB5010, AB5020, AB5030 BM380 BP810 BP820 JC282 JC283 JC756 JC757 JD303 JD304 JE120 JN453 JN693 JN777 JJ200 JJ385
HBS003 ☉ (22-29009B) M11x1.25x140mm (x10)	JC757 ■ (31-025817-10) JC282 ■ (31-024625-20) ☉ JE120 (31-024767-00)	JN693 [128] (31-026198-10)	JJ385 [148] (50-026131-00)	PA565 (x8) (50-305900-50) HR342 ■ (24-30590-05/0)	NC006 35x48x7mm, MVQ (50-319161-00) NB700 31x50x8mm, FPM (50-306551-50) NB806 90x104x11mm, FPM (50-306552-00)	NB575 [2]■		AB5010, AB5020, AB5030 BM380 BP810 BP820 JC282 JC283 JC756 JC757 JD303 JD304 JE120 JN453 JN693 JN777 JJ200 JJ385
HBS003 ☉ (22-29009B) M11x1.25x140mm (x10)	JC756 ■ (31-025820-20) JC282 ■ (31-024625-20) ☉ JE120 (31-024767-00)	JN693 [128] (31-026198-10)	JJ385 [148] (50-026131-00)	PA565 (x8) (50-305900-50) HR342 ■ (24-30590-05/0)	NC006 35x48x7mm, MVQ (50-319161-00) NB700 31x50x8mm, FPM (50-306551-50) NB701 86x104x11mm, FPM (50-306261-50) →12/85 NB806 90x104x11mm, FPM (50-306552-00) 01/86 →	NB575 [2]■ NB807 [2]■		AB5010, AB5020, AB5030 BM380 BP810 BP820 JC282 JC283 JC756 JC757 JD303 JD304 JE120 JN453 JN693 JN777 JJ200 JJ385
HBS003 ☉ (22-29009B) M11x1.25x140mm (x10)	JC283 ■ (31-025183-10) JC282 ■ (31-024625-20) ☉ JE120 (31-024767-00)	JN453 [127] (31-024572-00)	JJ200 (31-025011-00)	HR343 ■ (24-30602-50/0)	NC006 35x48x7mm, MVQ (50-319161-00) NB700 31x50x8mm, FPM (50-306551-50) NB701 86x104x11mm, FPM (50-306261-50)	NB575 [2]■		AB5010, AB5020, AB5030 BM380 BP810 BP820 JC282 JC283 JC756 JC757 JD303 JD304 JE120 JN453 JN693 JN777 JJ200 JJ385
HBS003 ☉ (22-29009B) M11x1.25x140mm (x10)	JC757 ■ (31-025817-10) JC282 ■ (31-024625-20) ☉ JE120 (31-024767-00)	JN693 [128] (31-026198-10)	JJ385 [148] (50-026131-00)	HR342 ■ (24-30590-05/0)	NC006 35x48x7mm, MVQ (50-319161-00) NB700 31x50x8mm, FPM (50-306551-50) NB806 90x104x11mm, FPM (50-306552-00)	NB575 [2]■		AB5010, AB5020, AB5030 BM380 BP810 BP820 JC282 JC283 JC756 JC757 JD303 JD304 JE120 JN453 JN693 JN777 JJ200 JJ385
HBS003 ☉ (22-29009B) M11x1.25x140mm (x10)	JC756 ■ (31-025820-20) JC282 ■ (31-024625-20) ☉ JE120 (31-024767-00)	JN693 [128] (31-026198-10)	JJ385 [148] (50-026131-00)	PA565 (x8) (50-305900-50) HR342 ■ (24-30590-05/0)	NC006 35x48x7mm, MVQ (50-319161-00) NB700 31x50x8mm, FPM (50-306551-50) NB806 90x104x11mm, FPM (50-306552-00)	NB575 [2]■ NB807 [2]■		AB5010, AB5020, AB5030 BM380 BP810 BP820 JC282 JC283 JC756 JC757 JD303 JD304 JE120 JN453 JN693 JN777 JJ200 JJ385
HBS003 ☉ (22-29009B) M11x1.25x140mm (x10)	JC756 ■ (31-025820-20) JC282 ■ (31-024625-20) ☉ JE120 (31-024767-00)	JN693 [128] (31-026198-10)	JJ385 [148] (50-026131-00)	PA565 (x8) (50-305900-50) HR342 ■ (24-30590-05/0)	NC006 35x48x7mm, MVQ (50-319161-00) NB700 31x50x8mm, FPM (50-306551-50) NB806 90x104x11mm, FPM (50-306552-00)	NB575 [2]■ NB807 [2]■		AB5010, AB5020, AB5030 BM380 BP810 BP820 JC282 JC283 JC756 JC757 JD303 JD304 JE120 JN453 JN693 JN777 JJ200 JJ385
HBS003 ☉ (22-29009B) M11x1.25x140mm (x10)	JC756 ■ (31-025820-20) JC282 ■ (31-024625-20)	JN693 [128] (31-026198-10)	JJ385 [148] (50-026131-00)	PA565 (x8) (50-305900-50) HR342 ■ (24-30590-05/0)	NC006 35x48x7mm, MVQ (50-319161-00) NB700 31x50x8mm, FPM (50-306551-50) NB806 90x104x11mm, FPM (50-306552-00)	NB575 [2]■ NB807 [2]■		AB5010, AB5020, AB5030 BM380 BP810 BP820 JC282 JC283 JC756 JC757 JD303 JD304 JE120 JN453 JN693 JN777 JJ200 JJ385



KW/PS



Cavalier 2.0L i 16V 09/93 → 11/95 127						BY250 (Fibre) (30-027987-10)	DY250 (21-27987-20/0)	EC130 (22-28793-00/0) HC5007 [212] (22-28386-00/0)
Cavalier 2.0L SRi 16V 09/93 → 11/95 X 20 XEV 1998 4 86.00 Injection, DOHC 100/136								
Cavalier 2.0L i 16V 09/88 → 11/95 128 Cavalier 2.0L i 16V 4x4 09/88 → 11/95 Cavalier 2.0L i 4x4 01/92 → 11/93						BS720 (Fibre) (30-026310-10)	DS720 (21-26310-22/0)	ES720 (22-27206-00/0)
C 20 XE 1998 4 86.00 Injection, DOHC 110/150								
Cavalier 2.5 V6 4x4 06/92 → 11/94 129						BY260 (Fibre) (30-027427-00)	DY260 (21-27427-21/0)	ES720 (22-27206-00/0)
C 20 LET 1998 4 86.00 Injection, DOHC 150/204								
Cavalier 2.5L V6 02/93 → 11/95 130						BY270 (Fibre) (x2) (30-027690-00)	DY270 (21-27690-20/0)	
C 25 XE 2498 6 81.60 Injection, DOHC, V6 125/170								
Combo Van 1.2L 07/94 → 10/01 131						BW170 (Fibre) (30-027215-00)	DW170 (21-27215-20/0)	ES260 [248] (22-27194-00/0)
C 12 NZ 1195 4 72.00 Injection, SOHC 33/45 X 12 SZ 1195 4 72.00 SPi, SOHC 33/45								
Combo 1.4L 01/04 → 132						AH5030 (MLS) (30-030366-00)	CH5030 (21-30366-00/0)	
Z 14 XEP 1364 4 73.40 Injection, DOHC 66/89								
Combo Van 1.4L 07/94 → 10/01 133						BS260 (Fibre) (30-026329-10)	DS260 (21-26329-21/0)	EK470 (22-27194-05/0)
C 14 NZ 1389 4 77.60 SPi, SOHC 44/60								
Combo Van 1.4L 07/94 → 10/01 134						BS260 (Fibre) (30-026329-10)	DS261 (21-26329-22/0)	ES260 [248] (22-27194-00/0)
C 14 SE 1389 4 77.60 Injection, SOHC 60/81								
Combo Van 1.6L 10/01 → 135						AE5920 (Steel) (30-029996-00)	CE5920 (21-29996-20/0)	EB5541 [8] (22-27665-03/0)
Z 16 SE 1598 4 79.00 Injection, SOHC 62-64/ 84-87								

								
HBS054  (22-29013B) M11x1.25x105mm (x10)	JD451  (31-027699-00) JD450  (31-027684-00) JE120  (31-024767-00)	JP016 (50-027683-00)	JJ615 (31-028793-00) JJ616  [212] (31-028386-00) JJ617  [212] (31-028385-00)	HR791  24-30614-76/0	NC006  (x2) 35x48x7mm, MVQ (50-319161-00) NB700  31x50x8mm, FPM (50-306551-50) NB806  90x104x11mm, FPM (50-306552-00)			 AE5920  BS260  BS720  BW170  BY250  BY260  BY270  JC281  JC823  JC824  JD430  JD451  JD455  JD456  JD457  JD458  JD459  JD5201  JD5398  JD5399  JE120  JM5094
HBS035  (22-29005B) M11x1.25x110mm (x10) →Eng.14137011 HBS054  (22-29013B) M11x1.25x105mm (x10) Eng.14137012→	JD455  (31-026335-10) JD430  (31-025888-00)	JM950 (50-026336-10)	JJ459 [148] (31-027206-00)	PA565 (x16) (50-305900-50) HR342  (x2) (24-305900-05/0)	NC006  (x2) 35x48x7mm, MVQ (50-319161-00) NB884  38x50x5.5mm, FPM (50-319010-00) NB806  90x104x11mm, FPM (50-306552-00)	NB575 [2] 		 JM5095  JM950  JN626  JN929  JP016  JH5005  JH5052  JJ120  JJ459  JJ615  JJ616  JJ617
HBS035  (22-29005B) M11x1.25x110mm (x10) →Eng.14003804 HBS054  (22-29013B) M11x1.25x105mm (x10) Eng.14003805→	JD455  (31-026335-10) JD456  (31-027459-00)	JM950 (50-026336-10)	JJ459 (x2) [148] (31-027206-00)	PA565 (x16) (50-305900-50) HR342  (x2) (24-305900-05/0)	NC006  (x2) 35x48x7mm, MVQ (50-319161-00) NB884  38x50x5.5mm, FPM (50-319010-00) NB806  90x104x11mm, FPM (50-306552-00)	NB807 [2] 		 JC281  JC823  JC824  JD430  JD451  JD455  JD456  JD457  JD458  JD459  JD5201  JD5398  JD5399  JE120  JM5094
HBS164  (22-29011B) M11x1.25x105mm (x16)	JD5201  (31-027700-00) JD458   (31-027688-00) JD457   (x2) (31-027686-00) JD459  (x2) (31-027698-00)	JM5095  (50-027697-00) JM5094  (50-027696-00) HM5294  (24-27696-00/0)	JH5052 (31-027689-00)	HR5062  24-30614-73/0	NC006 (x4) 35x48x7mm, MVQ (50-319161-00) NB884  38x50x5.5mm, FPM (50-319010-00) NB806  90x104x11mm, FPM (50-306552-00)			 JC824  JD430  JD451  JD455  JD456  JD457  JD458  JD459  JD5201  JD5398  JD5399  JE120  JM5094
HBS002  (22-29098B) M10x1.25x140mm (x10)	JC824  (31-026334-00) JC281  (31-024312-10)	JN626 (31-026099-10)	JH5005 [116] (31-027194-00) JJ120	PA565 (x8) (50-305900-50) HR342  (24-305900-05/0)	NC006  35x48x7mm, MVQ (50-319161-00) NB697  26x42x8mm, FPM (50-306704-00) NB698  80x98x10mm, FPM (50-319273-00)			 JD457  JD458  JD459  JD5201  JD5398  JD5399  JE120  JM5094
HBS002  (22-29098B) M10x1.25x140mm (x10)	JC824  (31-026334-00) JC281  (31-024312-10)	JN929 (50-027192-10)	JH5005 [116] (31-027194-00) JJ120	PA565 (x8) (50-305900-50) HR342  (24-305900-05/0)	NC006  35x48x7mm, MVQ (50-319161-00) NB697  26x42x8mm, FPM (50-306704-00) NB698  80x98x10mm, FPM (50-319273-00)			 JD457  JD458  JD459  JD5201  JD5398  JD5399  JE120  JM5094
HBS002  (22-29098B) M10x1.25x140mm (x10)	JD5398  (31-029997-00) JD5399  (31-029998-00)	JN929 (50-027192-10)		PA565 (x8) (50-305900-50) HR342  (24-305900-05/0)	NC006  35x48x7mm, MVQ (50-319161-00) NB697  26x42x8mm, FPM (50-306704-00) NB698  80x98x10mm, FPM (50-319273-00)			 JE120  JM5094



KW/PS



Combo Van 1.7L D Diesel		07/94 → 10/01		136		AB5010 (MLS), 1.40mm (30-029163-00) AB5020 (MLS), 1.45mm, 1 Hole (30-029164-00) AB5030 (MLS), 1.50mm, 2 Holes (30-029165-00)		CY811▲■ (21-27776-22/0)		FY811▲ (20-27776-02/0)	
17 D (4EE1)/X 17 D (4EE1)	1686	4	79.00		44/60						
Combo Van 1.7L DI 16V Diesel		09/01 →		137		AE5520 (MLS), 1.45mm, 1 Hole (30-029904-00) AE5530 (MLS), 1.50mm, 2 Holes (30-029905-00) AE5540 (MLS), 1.55mm, 3 Notches (30-029906-00)		CE5521▲ (21-29904-21/0)		EE5520 (22-29904-00/0)	
Combo Van 1.7L DTI 16V Diesel		10/01 →									
Y 17 DTL	1686	4	79.00	Direct Injection, DOHC	48/65						
Y 17 DT	1686	4	79.00	Direct Injection, DOHC	55/75						
Corsa 1.0L 12V Mk II		11/03 →		138		AE5950 (Steel) (30-029101-00)		CE5950 (21-29101-00/0)			
Corsa 1.0L Mk III		07/06 →									
Z 10 XEP	998	3	73.40	Injection, DOHC	44/60						
Corsa 1.0L i 12V		11/96 → 09/00		139		AB5140 (MLS) (30-028029-00)		CB5140■ (21-28029-20/0)		EB5140 (22-29175-00/0)	
X 10 XE	973	3	72.50	Injection, DOHC	40/54						
Corsa 1.2L 16V		09/00 →		140		AB5240 (MLS) (30-028390-20) →Ch.369999999		CB5240■☒ (21-28390-21/0) →Ch.369999999		EB5240 (22-29169-00/0)	
Corsa 1.2L 16V Dualfuel		08/01 →									
Corsa Van 1.2L 16V Dualfuel		08/01 →				AH5030 (MLS) (30-030366-00) Ch.46000001 →		CH5030 (21-30366-00/0) Ch.46000001 →			
Z 12 XE	1199	4	72.50	Injection, DOHC	55/75						
Corsa 1.2L i		03/93 → 09/00		141		BW170 (Fibre) (30-027215-00)		DW170 (21-27215-20/0)		ES260 [248] (22-27194-00/0)	
C 12 NZ	1195	4	72.00	Injection, SOHC	33/45						
X 12 SZ	1195	4	72.00	SPi, SOHC	33/45						
Corsa 1.2L i 16V		03/98 → 09/00		142		AB5240 (MLS) (30-028390-20)		CB5241■ (21-28390-20/0)		EB5240 (22-29169-00/0)	
X 12 XE	1199	4	72.50	Injection, DOHC	48/65						
Corsa 1.2L Mk III		07/06 →		143		AH5030 (MLS) (30-030366-00)		CH5031 (21-30366-01/0)			
Z 12 XEP	1229	4	73.40	Injection, DOHC	59/80						
Corsa 1.3L CDTI 16V Diesel		04/04 →		144		AD5800 (MLS), 0.72mm (30-029762-00) AD5810 (MLS), 0.82mm, 1 Hole (30-029763-00) AD5820 (MLS), 0.92mm, 2 Holes (30-029764-00)		CD5800▲ (21-29762-20/0)			
Corsa Van 1.3L CDTI 16V Diesel		04/04 →									
Z 13 DT	1248	4	69.80	Direct Injection	51/70						











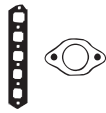

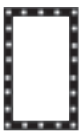

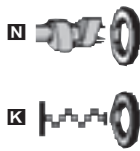

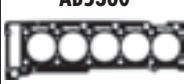





















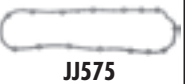

















HBS036 ® (22-29001B) M12x1.5x102mm (x10)	JD303 ■ JD304 ■ JE5029 (31-027779-00)	JN777 (50-027776-00)		PA658 (x8) (50-319265-00)	NJ449 40x52x6mm, NBR (50-319266-00) NJ449E 40x52x6mm, NBR (50-319266-00) NK103 ■ 87x100x8.5mm, FPM		AB5010, AB5020, AB5030 JD5336 JD5412 JE5017 JE5024 AB5140	
HBS036 ® (22-29001B) M12x1.5x102mm (x10)	JD5332 ■ (31-029912-00) →Eng.721439 JD5333 ■ (31-029913-00) Eng.721439 → JD5336 ■■ (31-029916-00) Eng.721439 → JD5329 ■ (31-029909-00)	JM5197 (50-029907-00)		HR791 ■ 24-30614-76/0	NB884 38x50x5.5mm, FPM (50-319010-00) NJ449E 40x52x6mm, NBR (50-319266-00) NK103 ■ 87x100x8.5mm, FPM		AB5240 JM5048 AD5800 JM5085 AD5810 JM5121 AD5820 JN626 AE5520, AE5530, AE5540 JN777	
HBS253 ⊕ (22-29015B) M8x1.25x119mm (x10)	JD5904 ■ (x4) (50-030368-00) (FPM) JE5017 ■ (31-029177-00)	JM5121 (50-029185-00)	JH5037 (31-029175-00)	PA5025 (x12) (50-319386-00)	NA5108 ■ 42x55x7mm, FPM (50-319392-00) NB698 ■ 80x98x10mm, FPM (50-319273-00)	JR5030 [11]	AD5810 JM5121 AD5820 JN626 AE5520, AE5530, AE5540 JN777	
HBS253 ⊕ (22-29015B) M8x1.25x119mm (x10)	JD5223 ■ (31-029178-00) JE5017 ■ (31-029177-00)	JM5085 (50-029176-00)	JH5037 (31-029175-00)	PA5025 (x12) (50-319386-00) HR5096 ■ (24-31938-61/0)	NA5108 ■ 42x55x7mm, FPM (50-319392-00) NB698 ■ 80x98x10mm, FPM (50-319273-00)	JR5030 [11]	AE5520, AE5530, AE5540 JN777	
HBS252 ⊕ (22-29014B) M8x1.25x119mm (x12)	JD5117 ■ (x4) (50-029186-00) →Ch.36999999 JD5904 ■ (x4) (50-030368-00) (FPM) Ch.46000001 → JE5024 ■ (31-029170-00)	JM5048 (50-029167-00) →Ch.1G001502 JM5071 (50-029232-00) Ch.1G001503 →	JH5036 (31-029169-00)	HR5048 ■ (24-31938-60/0)	NA5108 ■ 42x55x7mm, FPM (50-319392-00) NB698 ■ 80x98x10mm, FPM (50-319273-00)	JR5030 [11]	AE5950 JH5005 JH5036 BW170 JC281 JH5037 JJ120	
HBS002 ⊕ (22-29098B) M10x1.25x140mm (x10)	JC824 ■ (31-026334-00) JC281 ■ (31-024312-10)	JN626 (31-026099-10)	JH5005 [116] (31-027194-00) JJ120	PA565 (x8) (50-305900-50) HR342 ■ (24-30590-05/0)	NC006 ■ 35x48x7mm, MVQ (50-319161-00) NB697 ■ 26x42x8mm, FPM (50-306704-00) NB698 ■ 80x98x10mm, FPM (50-319273-00)	JR5030 [11]	JC824 JD303 JD304 JD5117 JD5223 JD5329 JD5332	
HBS252 ⊕ (22-29014B) M8x1.25x119mm (x12)	JE5024 ■ (31-029170-00)	JM5048 (50-029167-00)	JH5036 (31-029169-00)	HR5048 ■ (24-31938-60/0)	NA5108 ■ 42x55x7mm, FPM (50-319392-00) NB698 ■ 80x98x10mm, FPM (50-319273-00)	JR5030 [11]	JD303 JD304 JD5117 JD5223 JD5329 JD5332	
HBS252 ⊕ (22-29014B) M8x1.25x119mm (x12)	JD5904 ■ (x4) (50-030368-00) (FPM)	JM5071 (50-029232-00)	JH5036 (31-029169-00)	HR5048 ■ (24-31938-60/0)	NA5108 ■ 42x55x7mm, FPM (50-319392-00) NB698 ■ 80x98x10mm, FPM (50-319273-00)	JR5030 [11]	JD5117 JD5223 JD5329 JD5332	
HBS353 ⊕ (22-17025B) M10x1.25x119mm (x10)	JD5411 ■ (50-030025-00) JD5412 ■■ (50-030026-00) JD5413 ■ (31-030027-00) (MLS)	JM5259 (31-030023-00)	HR397 [57] 34-000410-00	HR5088 ■ (24-31952-10/0)	NA5223 ■ 40x52x7mm, FPM (50-319520-00) NA5230 ■ 78x100x9mm, PTFE (50-319522-00)	KK5646 [45]	JD5223 JD5329 JD5332	



KW/PS



Corsa 1.4L i						03/93 → 09/00	145	BS260 (Fibre)	DS260	EK470
Corsa 1.4L i S						03/93 → 09/00		(30-026329-10)	(21-26329-21/0)	(22-27194-05/0)
C 14 NZ/X 14 SZ	1389	4	77.60	SPi, SOHC	44/60			C14NZ	C14NZ	
C 14 SE	1389	4	77.60	Injection, SOHC	60/81			DS261	ES260 [248]	
								(21-26329-22/0)	(22-27194-00/0)	
								X14SZ	X14SZ	
Corsa 1.4L i 16V						09/00 →	146	AB5360 (MLS)	CB5360	EB5360
Z 14 XE	1389	4	77.60	Injection, DOHC	66/89		(30-029200-00)	(21-29200-20/0)	(22-27665-02/0)	
									→Eng.02M25253	
									→Eng.20U75999	
									EB5541 [8]	
									(22-27665-03/0)	
									Eng.02M25254 →	
									Eng.20U76000 →	
Corsa 1.4L i 16V						09/94 → 09/00	147	AY210 (Fibre)	CY210	EY230
Corsa Convertible 1.4L i 16V						01/98 →		(30-027985-00)	(21-27985-21/0)	(22-27665-01/0)
X 14 XE	1389	4	77.60	Injection, DOHC	66/89					
Corsa 1.4L Mk III						07/06 →	148	AH5030 (MLS)	CH5030	
Z 14 XEP	1364	4	73.40	Injection, DOHC	66/89		(30-030366-00)	(21-30366-00/0)		
Corsa Van 1.4L i						01/94 → 09/00	149	BS260 (Fibre)	DS260	EK470
C 14 NZ	1389	4	77.60	SPi, SOHC	44/60		(30-026329-10)	(21-26329-21/0)	(22-27194-05/0)	
Corsa 1.5L D Diesel						03/93 → 09/00	150	AY840 (MLS), 1.40mm	CY811 ▲ ■	FY811 ▲
Corsa 1.5L TD Diesel						03/93 → 10/96		(30-028998-00)	(21-27776-22/0)	(20-27776-02/0)
15 D	1488	4	76.00	SOHC	37/50		→Eng.975024			
X 15 DT (T4EC1)	1488	4	76.00		49/67		AY850 (MLS), 1.45mm, 1 Hole			
15 DT (T4EC1)	1488	4	76.00		49-53/ 67-72		(30-028999-00)			
							→Eng.975024			
							AY860 (MLS), 1.50mm, 2 Holes			
							(30-029000-00)			
							→Eng.975024			
							AY900 (MLS), 1.40mm			
							(30-029007-00)			
							Eng.975025 →			
							AY910 (MLS), 1.45mm, 1 Hole			
							(30-029006-00)			
							Eng.975025 →			
							AY920 (MLS), 1.50mm, 2 Holes			
							(30-029008-00)			
							Eng.975025 →			
Corsa 1.6L GSI 16V						03/93 → 09/00	151	AY220 (Fibre)	DY231	EY230
C 16 XE	1598	4	79.00	Injection, DOHC	78-80/ 106- 109			(21-27986-23/0)	(22-27665-01/0)	
Corsa 1.6L i 16V						09/94 → 09/00	152	AY220 (Fibre)	CY220	EY230
X 16 XE	1598	4	79.00	Injection, DOHC	78/106			(21-27986-21/0)	(22-27665-01/0)	







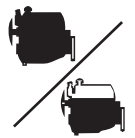



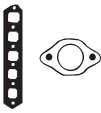

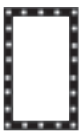

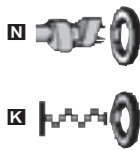

















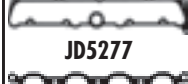

								
HBS002 ® (22-29098B) M10x1.25x140mm (x10)	JC823 ■ (31-027191-10) X14SZ JC824 ■ (31-026334-00) C14NZ JC281 ■ (31-024312-10)	JN626 (31-026099-10) C14NZ JN929 (50-027192-10) X14SZ	JH5005 [116] (31-027194-00) JJ120	PA565 (x8) (50-305900-50) HR342 ■ (24-30590-05/0)	NB697 ■ (x2) 35x48x7mm, MVQ (50-319161-00) NB697 ■ 26x42x8mm, FPM (50-306704-00) NB698 ■ 80x98x10mm, FPM (50-319273-00)			 AB5360  AD5720  AY210  AY220  AY840, AY850, AY860  AY900, AY910, AY920  BS260  JC281  JC824  JD303  JD304  JD444  JD445  JD448  JD5147  JD5148  JD5149  JD5269  JM5059  JN626  JN777  JP008
HBS055 ® (22-29012B) M10x1.25x153mm (x10)	JD5147 ■ (31-029203-00) JD5149 ■ ■ (31-029207-00) JD5148 ■ (31-029204-00)	JM5059 (50-029202-00)	JJ575 [148] (50-027665-00)	HR791 ■ 24-30614-76/0	NB697 ■ (x2) 35x48x7mm, MVQ (50-319161-00) NB697 ■ 26x42x8mm, FPM (50-306704-00) NB698 ■ 80x98x10mm, FPM (50-319273-00)			 JJ120  JJ575
HBS055 ® (22-29012B) M10x1.25x153mm (x10)	JD5269 ■ (31-027984-00) JD445 ■ ■ (31-027881-00) JD444 ■ (31-027878-00)	JP009 ■ (50-027983-00) JP008 ■ (50-027982-00)	JJ575 [148] (50-027665-00)	HR791 ■ 24-30614-76/0	NB697 ■ (x2) 35x48x7mm, MVQ (50-319161-00) NB697 ■ 26x42x8mm, FPM (50-306704-00) NB698 ■ 80x98x10mm, FPM (50-319273-00)			 JC281  JC824  JD303  JD304  JD444  JD445  JD448  JD5147  JD5148  JD5149  JD5269  JM5059  JN626
	JD5904 ■ (x4) (50-030368-00) (FPM)	JM5071 (50-029232-00)						
HBS002 ® (22-29098B) M10x1.25x140mm (x10)	JC824 ■ (31-026334-00) JC281 ■ (31-024312-10)	JN626 (31-026099-10)	JH5005 [116] (31-027194-00) JJ120	PA565 (x8) (50-305900-50) HR342 ■ (24-30590-05/0)	NB697 ■ 35x48x7mm, MVQ (50-319161-00) NB697 ■ 26x42x8mm, FPM (50-306704-00) NB698 ■ 80x98x10mm, FPM (50-319273-00)	NB575 [2] ■		
HBS036 ® (22-29001B) M12x1.5x102mm (x10)	JD303 ■ JD5914 ■ (31-027778-00) JD304 ■	JN776 →12/89 JN777 (50-027776-00) 01/90→	JH5058 (31-027781-00)	PA658 (x8) (50-319265-00)	NJ449 ■ 40x52x6mm, NBR (50-319266-00) NJ449 ■ 40x52x6mm, NBR (50-319266-00) NK103 ■ 87x100x8.5mm, FPM			 JD444  JD445  JD448  JD5147  JD5148  JD5149  JD5269  JM5059  JN626  JN777  JP008
HBS055 ® (22-29012B) M10x1.25x153mm (x10)	JD448 ■ (31-027880-00) JD444 ■ (31-027878-00)	JP009 ■ (50-027983-00) JP008 ■ (50-027982-00)	JJ575 [148] (50-027665-00)	HR791 ■ 24-30614-76/0	NB697 ■ 35x48x7mm, MVQ (50-319161-00) NB697 ■ 26x42x8mm, FPM (50-306704-00) NB698 ■ 80x98x10mm, FPM (50-319273-00)			 JM5059  JN626  JN777  JP008
HBS055 ® (22-29012B) M10x1.25x153mm (x10)	JD448 ■ (31-027880-00) JD445 ■ ■ (31-027881-00) JD444 ■ (31-027878-00)	JP009 ■ (50-027983-00) JP008 ■ (50-027982-00)	JJ575 [148] (50-027665-00)	HR791 ■ 24-30614-76/0	NB697 ■ (x2) 35x48x7mm, MVQ (50-319161-00) NB697 ■ 26x42x8mm, FPM (50-306704-00) NB698 ■ 80x98x10mm, FPM (50-319273-00)			



KW/PS

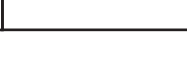

Corsa 1.7L CDTI 16V Diesel		04/04 →		153	AE5520 (MLS), 1.45mm, 1 Hole (30-029904-00) AE5530 (MLS), 1.50mm, 2 Holes (30-029905-00) AE5540 (MLS), 1.55mm, 3 Notches (30-029906-00)	CE5523▲ (21-29904-23/0)	EE5520 (22-29904-00/0)
Z 17 DTH	1686	4	79.00	Direct Injection, DOHC	74/100		
Corsa 1.7L D Diesel		02/96 →09/00		154	AB5010 (MLS), 1.40mm (30-029163-00) AB5020 (MLS), 1.45mm, 1 Hole (30-029164-00) AB5030 (MLS), 1.50mm, 2 Holes (30-029165-00)	CY811▲■ (21-27776-22/0)	FY811▲ (20-27776-02/0)
Corsa Van 1.7L D Diesel		01/94 →09/00					
17 D (4EE1)/X 17 D (4EE1)	1686	4	79.00		44/60		
Corsa 1.7L DI 16V Diesel		09/00 →		155	AE5520 (MLS), 1.45mm, 1 Hole (30-029904-00) AE5530 (MLS), 1.50mm, 2 Holes (30-029905-00) AE5540 (MLS), 1.55mm, 3 Notches (30-029906-00)	CE5521▲ (21-29904-21/0)	EE5520 (22-29904-00/0)
Corsa 1.7L DTI 16V Diesel		09/00 →					
Corsa Van 1.7L DI 16V Diesel		09/00 →					
Corsa Van 1.7L DTI 16V Diesel		09/00 →					
Y 17 DTL	1686	4	79.00	Direct Injection, DOHC	48/65		
Y 17 DT	1686	4	79.00	Direct Injection, DOHC	55/75		
Corsa 1.8L 16V		09/00 →		156	AC5460 (MLS) (30-028674-00)	CC5460 (21-28674-20/0)	
Z 18 XE	1799	4	80.50	Injection, DOHC	87/92/ 118- 125		
Corsavan 1.4L Mk II		11/03 →11/06		157	AH5030 (MLS) (30-030366-00)	CH5030 (21-30366-00/0)	
Z 14 XEP	1364	4	73.40	Injection, DOHC	66/89		
Frontera 2.0L i		03/92 →10/98		158	BP820 (Fibre) (30-025819-10)	DP820 (21-25819-21/0)	EC100 (22-27206-01/0) X20SE EK482 (22-26131-01/0) C20NE
C 20 NE	1998	4	86.00	Injection, SOHC	85/115		
X 20 SE	1998	4	86.00	Injection, SOHC	85/116		
Frontera 2.2L DTI Diesel		10/98 →		159	AB5671 (MLS), 1.30mm, 1 Notch AB5681 (MLS), 1.40mm, 2 Notches	CB5670▲■ (21-29011-20/0) →Eng.2V599999 CB5671▲■ (21-29011-21/0) Eng.3V500001 →	EB5671 (22-29011-01/0)
X 22 DTH	2172	4	84.00	Direct Injection	85/116		
Y 22 DTH	2172	4	84.00	Direct Injection	85-88/ 116- 120		
Frontera 2.2L i		10/98 →		160	BY250 (Fibre) (30-027987-10)	DY254 (21-27987-23/0) X22SE DY255 (21-27987-24/0) Y22SE	EC102 (22-27206-03/0)
Y 22 SE	2198	4	86.00	Injection, DOHC	100/136		
X 22 SE	2198	4	86.00	Injection, DOHC	100- 104/ 136- 141		







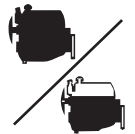



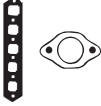

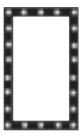

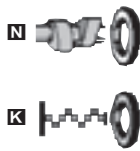









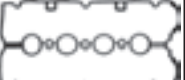

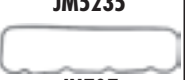























































								
HBS036 ® (22-29001B) M12x1.5x102mm (x10)	JD5334 ■ (31-029914-00) JD5331 ■ (x2) (31-029911-00)	JM5198 (50-029908-00)		HR791 ■ 24-30614-76/0	NB884 38x50x5.5mm, FPM (50-319010-00) NJ449 ■ 40x52x6mm, NBR (50-319266-00) NK103 ■ 87x100x8.5mm, FPM			 AB5010, AB5020, AB5030  JM5092  AC5460  JM5159  AE5520, AE5530, AE5540  JN693  BP820  JN777  BY250  JP016  JC282  JJ385  JC756  JD303  JD304  JD451  JD5196  JD5197  JD5255  JD5256  JD5277  JD5329  JD5331  JD5332  JD5334  JD5336  JD5347  JE120
HBS036 ® (22-29001B) M12x1.5x102mm (x10)	JD303 ■ JD304 ■  JE5029 (31-027779-00)	JN777 (50-027776-00)		PA658 (x8) (50-319265-00)	NJ449 40x52x6mm, NBR (50-319266-00) NJ449 ■ 40x52x6mm, NBR (50-319266-00) NK103 ■ 87x100x8.5mm, FPM			
HBS036 ® (22-29001B) M12x1.5x102mm (x10)	JD5332 ■ (31-029912-00) →Eng.721439 JD5333 ■ (31-029913-00) Eng.721439 → JD5336 ■ (x2) (31-029916-00) Eng.721439 → JD5329 ■ (31-029909-00)	JM5197 (50-029907-00)		HR791 ■ 24-30614-76/0	NB884 38x50x5.5mm, FPM (50-319010-00) NJ449 ■ 40x52x6mm, NBR (50-319266-00) NK103 ■ 87x100x8.5mm, FPM			
HBS055 ® (22-29012B) M10x1.25x153mm (x10)	JD5196 ■ (31-029039-00) JD5197 ■ (31-029040-00) JD5904 ■ (x4) (50-030368-00) (FPM)	JM5092 (50-029087-00)		HR5048 ■ (24-31938-60/0)	NC006 ■ (x2) 35x48x7mm, MVQ (50-319161-00) NC065 ■ 30x40x7mm, FPM (50-306142-00) NB698 ■ 80x98x10mm, FPM (50-319273-00)			
HBS003 ® (22-29009B) M11x1.25x140mm (x10) →12/96 HBS053 ® (22-29099B) M11x1.25x140mm (x10) 01/97 →	JC756 ■ (31-025820-20) JC282 ■ (31-024625-20)  JE120 (31-024767-00)	JN693 [128] (31-026198-10)	JJ385 (x2) [148] (50-026131-00) C20NE JJ459 (x2) [148] (31-027206-00) X20SE	PA565 (x8) (50-305900-50) HR342 ■ (24-305900-05/0)	NC006 ■ 35x48x7mm, MVQ (50-319161-00) NB700 ■ 31x50x8mm, FPM (50-306551-50) NB806 ■ 90x104x11mm, FPM (50-306552-00)			
HBS298 ® (22-29016B) M12x1.50x235mm (x10)	JD5255 ■ (31-029721-00) JD5347 ■ (x2) (31-029942-00) →Eng.2V599999 JD5277 ■ (x2) (31-029723-00) Eng.3V500001 → JD5256 ■ (31-029722-00)	JM5159 (50-029633-00)		HR791 ■ 24-30614-76/0	NA5069 ■ 55x68x8mm, FPM (50-319515-00) NA5209 ■ 99x114x11mm, FPM (50-319514-00)			
HBS054 ® (22-29013B) M11x1.25x105mm (x10)	JD451 ■ (31-027699-00) JD5737 ■ (31-030118-00) (MLS)	JP016 (50-027683-00)	JH5096 (31-030122-00) (Steel Elastomer)	HR791 ■ 24-30614-76/0	NC006 ■ (x2) 35x48x7mm, MVQ (50-319161-00) NB700 ■ 31x50x8mm, FPM (50-306551-50) NB806 ■ 90x104x11mm, FPM (50-306552-00)			



KW/PS



Frontera 2.2L i				03/95 → 10/98	161	BY250 (Fibre) (30-027987-10)	DY251 (21-27987-21/0)	EC100 (22-27206-01/0)
X 22 XE	2198	4	86.00	Injection, DOHC	100/136			
Frontera 2.3L TD Diesel				03/92 → 10/98	162	BR010 (Fibre), 1.30mm, 1 Hole (30-025657-10) BR020 (Fibre), 1.40mm, 2 Holes (30-025658-10) BR030 (Fibre), 1.50mm, 3 Holes (30-025659-10)		EJ161
23 DTR	2260	4	92.00	Indirect Injection, SOHC	74/100			
Frontera 2.4L i				03/92 → 10/98	163	BJ170 (Fibre) (30-025662-10)		
C 24 NE	2410	4	95.00	Injection, SOHC	92/125			
Frontera 2.5L TDS Diesel				09/96 → 10/98	164	AY400 (MLS), 1.42mm, 0 Notches (30-028472-00) BK570 (Fibre), 1.42mm, 0 Notches (x4) (30-025008-20) AY410 (MLS), 1.52mm, 2 Notches (30-028473-00) BP260 (Fibre), 1.52mm, 2 Notches (x4) (30-025013-20) AY420 (MLS), 1.62mm, 1 Notch (30-028474-00) BK580 (Fibre), 1.62mm, 1 Notch (x4) (30-025007-20)	DK570▲ [7] (21-25850-21/0)	GK572▲ [8] (20-25850-01/0)
25TDS (VM41B)	2499	4	92.00		85/115			
Frontera 2.8L TD Diesel				03/95 → 10/98	165	BR990 (MLS)	CD5400▲	ER993 GR991
28 TDI (4JB1T)	2771	4	93.00		83/113			
Frontera 3.2L i				10/98 →	166	AB5780 (MLS) ☒ AB5781 (MLS) ☒	CG5500	EG6240
6 VD1	3165	6	93.40		130- 151/ 177- 205			
Y 32 NE	3165	6	93.40	Direct Injection, DOHC	151/205			
Meriva 1.4L 16V Twinport				07/04 →	167	AH5030 (MLS) (30-030366-00)	CH5030 (21-30366-00/0)	
Z 14 XEP	1364	4	73.40	Injection, DOHC	66/89			
Meriva 1.6L i 16V Twinport				01/06 →	168	AE5930 (MLS) (30-029999-00)	CE5930 (21-29999-20/0)	
Z 16 XEP	1598	4	79.00	Injection, DOHC	74-77/ 101- 105			
Meriva 1.6L i				05/03 →	169	AE5920 (Steel) (30-029996-00)	CE5920 (21-29996-20/0)	EB5541 [8] (22-27665-03/0)
Z 16 SE	1598	4	79.00	Injection, SOHC	62-64/ 84-87			
Meriva 1.6L i 16V				05/03 →	170	AB5540 (MLS) (30-029209-00)	CB5540 (21-29209-20/0)	EB5541 [8] (22-27665-03/0)
Z 16 XE	1598	4	79.00	Injection, DOHC	63-74/ 85-101			

								
HBS054  (22-29013B) M11x1.25x105mm (x10)	JD451  (31-027699-00) JD450  (31-027684-00)	JP016 (50-027683-00)	JJ459 [148] (31-027206-00)	HR791  24-30614-76/0	NBNC006  (x2) 35x48x7mm, MVQ (50-319161-00) NB700  31x50x8mm, FPM (50-306551-50) NB806  90x104x11mm, FPM (50-306552-00)			 AB5540  JM5235  AE5920  JN707  AE5930  JN923  AY400, AY410, AY420  JN924  BK570, BP260, BK580  JN929  JP016  BR010, BR020, BR030  JP067  BR990  JP068  BY250  JH5019  JC928  JD025  JJ454  JD187  JJ459  JD451  JD5147  JD5148  JD5398  JD5399  JD5400  JD5401  JF123  JM5059
HBS163  (22-29010B) M13x1.50x134mm (x10)	JD5765 (31-025415-10)		JH5019 (50-026493-00)	PA543 (x8) (50-305908-10) HR794  (24-30590-81/0)	NB628  45x60x9mm, ACM (50-305272-00) NB690  81x100.1x11.5mm, FPM (50-319087-00)			
HBS161  (22-29007B) M12x1.50x64mm (x5) M12x1.50x97.5mm (x5)	JD187 (31-026476-10)	JN923 (50-026499-00) JN924 (x2)	JH5019  (50-026493-00)	HR336  (x2) (24-30656-05/0)	NB628  45x60x9mm, ACM (50-305272-00) NB469  77x100x11.5mm, FPM (50-306260-50)			
HBS108  (22-56003B) M14x2.0x137mm (x10) M12x1.75x115mm (x4) M12x1.75x79.5mm (x4)	JC928  (x4) (31-025852-10) JD025  (x4) (31-025849-10) JF123  (31-027523-00)	JP067 (31-025850-10) JP068 [9] (31-029626-00)						
HBS287  (22-20005B) M11x1.50x121mm (x18)	JD470  (31-029753-00)	JN707	HC5008  JJ454	PA418 (x8)	NJ267 42x55x9mm, NBR NJ014 50x68x9mm, NBR NJ322 95x118x10mm, NBR			
		JM5078 (x2)						
	JD5904  (x4) (50-030368-00) (FPM)	JM5071 (50-029232-00)						
HBS055  (22-29012B) M10x1.25x153mm (x10)	JD5400  (31-030002-00) JD5401  (31-030004-00)	JM5235 (50-029985-00)		HR5087  (24-31951-90/0)	NBNC006  (x2) 35x48x7mm, MVQ (50-319161-00) NA5174  31.5x42x7mm, FPM (50-319469-00) NB698  80x98x10mm, FPM (50-319273-00)			
HBS002  (22-29098B) M10x1.25x140mm (x10)	JD5398  (31-029997-00) JD5399  (31-029998-00)	JN929 (50-027192-10)		HR342  (24-30590-05/0)	NBNC006  35x48x7mm, MVQ (50-319161-00) NB697  26x42x8mm, FPM (50-306704-00) NB698  80x98x10mm, FPM (50-319273-00)			
HBS055  (22-29012B) M10x1.25x153mm (x10)	JD5147  (31-029203-00) JD5148  (31-029204-00)	JM5059 (50-029202-00)		HR791  24-30614-76/0	NBNC006  (x2) 35x48x7mm, MVQ (50-319161-00) NB697  26x42x8mm, FPM (50-306704-00) NB698  80x98x10mm, FPM (50-319273-00)			



KW/PS



Model		Year	CC	Cyls	Power (kW/PS)	Injection	Code	Part	Part
Meriva 1.7L CDTI 16V Diesel		04/04 →			171				
Z 17 DTH	1686	4	79.00	Direct Injection, DOHC	74/100		AE5520 (MLS), 1.45mm, 1 Hole (30-029904-00) AE5530 (MLS), 1.50mm, 2 Holes (30-029905-00) AE5540 (MLS), 1.55mm, 3 Notches (30-029906-00)	CE5523▲ (21-29904-23/0)	EE5520 (22-29904-00/0)
Meriva 1.8L i 16V		05/03 →			172				
Z 18 XE	1799	4	80.50	Injection, DOHC	87-92/ 118- 125		AC5460 (MLS) (30-028674-00)	CC5460 (21-28674-20/0)	
Midi 2.0L		01/90 →			173				
4ZC1	1995	4	88.00	SOHC	60/81		BP980 (Graphite)	DP980	GP980
Midi 2.2L D Diesel		06/90 →10/94			174				
4FD1	2189	4	88.00	Indirect Injection, SOHC	54-45/ 73-61		BR190 (Graphite) (30-028342-00)	DR190 (21-28342-20/0)	GR190
Monterey 3.0L DTI Diesel		07/98 →08/99			175				
4 JX1	2999	4	95.40		117- 118/ 159- 160		AG5090 (MLS), 1.25mm, 3 Holes	CG5090▲	
Monterey 3.1L TD Diesel		09/91 →07/98			176				
4 J62TC	3059	4	95.40	Direct Injection, OHV	84/114		AD5400 (Fibre), 1.7mm, 3 Holes		
Monterey 3.2L		06/92 →07/98			177				
6 VD1	3165	6	93.40		130- 151/ 177- 205		AG5080 (Fibre), 1.2mm	CG5500	EG6240
Monterey 3.5L V6 24V		07/98 →08/99			178				
6 VE1	3494	6	93.40	MPi	158/215		AB5780 (MLS) AB5781 (MLS)	CG5781	EG6240
Movano 1.9L DTI Diesel		09/00 →10/01			179				
F9Q 770	1870	4	80.00	Direct Injection, SOHC	59/80		AC5070 (Fibre), 1.35mm, 2 Notches (30-029474-00) →0.653mm AC5080 (Fibre), 1.45mm, 1 Notch (30-029475-00) 0.653→0.786mm AC5090 (Fibre), 1.55mm, 3 Notches (30-029476-00) 0.786mm→	CC5060▲ (21-29483-20/0)	EC5060 (22-29474-00/0)
Movano 1.9L DTI Diesel		10/01 →			180				
F9Q 774	1870	4	80.00	Direct Injection, SOHC	60/82		AC5070 (Fibre), 1.35mm, 2 Notches (30-029474-00) →0.653mm AC5080 (Fibre), 1.45mm, 1 Notch (30-029475-00) 0.653→0.786mm AC5090 (Fibre), 1.55mm, 3 Notches (30-029476-00) 0.786mm→	CC5060▲ (21-29483-20/0)	EC5060 (22-29474-00/0)
Movano 2.2L DTI Diesel		09/00 →			181				
G9T 720	2188	4	87.00	Direct Injection, DOHC	66/90		AE5210 (MLS), 1.24mm (30-029250-00)	CE5210	EE5220 (22-29037-00/0) G9T-720
Movano 2.5L CDTI Diesel		04/04 →			182				
G9U 754	2463	4	89.00	Direct Injection, DOHC	73/99		AE5220 (MLS) (30-029037-00)		EE5220 (22-29037-00/0)







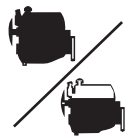



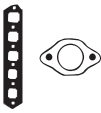

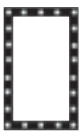

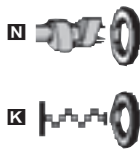







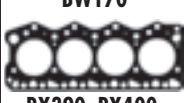
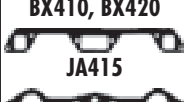













































































							 AC5070, AC5080, AC5090	 JJ358
HBS036 ® (22-29001B) M12x1.5x102mm (x10)	JD5334 ■ (31-029914-00) JD5331 ■ (x2) (31-029911-00)	JM5198 (50-029908-00)		HR791 ■ 24-30614-76/0	■ NB884 38x50x5.5mm, FPM (50-319010-00) ■ NJ449 ■ 40x52x6mm, NBR (50-319266-00) ■ NK103 ■ 87x100x8.5mm, FPM		 AC5460	
HBS055 ® (22-29012B) M10x1.25x153mm (x10)	JD5196 ■ (31-029039-00) JD5197 ■ (31-029040-00)	JM5092 (50-029087-00)		HR5048 ■ (24-31938-60/0)	■ NCO06 ■ (x2) 35x48x7mm, MVQ (50-319161-00) ■ NCO65 ■ 30x40x7mm, FPM (50-306142-00) ■ NB698 ■ 80x98x10mm, FPM (50-319273-00)		 AE5210	
	JC670 ■ JC683 ■	JN634 (50-028320-00) HL532 ■	JJ358	PA933 ■ (x8)	■ NJ454 30x45x8mm, NBR ■ NJ323 ■ 40x56x7mm, NBR ■ NJ322 ■ 95x118x10mm, NBR		 AE5220	
	JC429 ■ JC284 ■	JN456	JJ204		■ NJ321 28x47x8mm, NBR ■ NJ323 ■ 40x56x7mm, NBR ■ NJ322 ■ 95x118x10mm, NBR		 AE5520, AE5530, AE5540	
HBS419 (22-29027B) M11x1.50x110mm (x18)							 BP980	
							 BR190	
							 JC284	
							 JC429	
							 JC670	
							 JC683	
							 JD5196	
		JM5078 (x2)					 JD5197	
HBS120 ® (22-51008B) M12x1.50x118mm (x10)	JD5189	JM5086	JH5041 ≡KG5012 16x23x1.5mm	HR646 ■ 24-30670-60/0	■ NF846 25x42x7mm, FPM/ACM (50-319516-00) ■ NA5036 ■ 42x54x6mm, FPM (50-319473-00) ■ NF850 ■ 85x105x8mm, FPM (50-319183-00)	HL5017 [245]■	 JD5331	
HBS372 ® (22-51109B) M12x1.50x121mm (x10)	JD5189	JM5086	JH5041 ≡KG5012 16x23x1.5mm	HR646 ■ 24-30670-60/0	■ NF846 25x42x7mm, FPM/ACM (50-319516-00) ■ NA5036 ■ 42x54x6mm, FPM (50-319473-00) ■ NF850 ■ 85x105x8mm, FPM (50-319183-00)	HL5017 [245]■	 JD5334	
HBS373 ® (22-51110B) M12x1.50x131mm (x10)	JD5891 ■ JD5892	HM5290 ■					 JM5092	
HBS373 ® (22-51110B) M12x1.50x131mm (x10)							 JN456	
							 JN634	
							 JJ204	



KW/PS



Movano 2.5L D Diesel				10/98 → 09/00	183	AY290 (Fibre), 1.60mm [112] (30-027426-00) AY300 (Fibre), 1.70mm [112] (30-026654-20) AY310 (Fibre), 1.80mm [112] (30-026655-20)	DE588▲ [109] (21-26037-23/0)	FY291▲ [12] (20-27426-00/0)
S8U 770	2499	4	93.00	Indirect Injection	59/80			
Movano 2.5L DTI Diesel				10/01 →	184	AE5220 (MLS) (30-029037-00)	CE5210	EE5220 (22-29037-00/0) G9U-720/724
G9U 754	2463	4	89.00	Direct Injection, DOHC	73/99			
G9U 720/ G9U 724/G9U 750	2463	4	89.00	Direct Injection, DOHC	84/115			
G9U-720	2463	4	89.00		84/115			
Movano 2.8L DTI Diesel				10/98 → 10/01	185	BX390 (Fibre), 1.20mm [71] (30-027867-00)	DX391▲ (21-27867-21/0)	
Movano 2.8L TDI Diesel				10/98 → 10/01		BX400 (Fibre), 1.30mm [71] (30-027868-00) BX410 (Fibre), 1.40mm [71] (30-027883-00) BX420 (Fibre), 1.50mm [71] (30-027884-00)		
S9W 702	2799	4	94.40	Direct Injection, SOHC	84/114			
Nova 1.0L				09/82 → 03/93	186	BN010 (Fibre) (30-025128-10)	DN010 (21-25128-24/0) → 12/84	ET820 (22-20159-02/0)
10 S	993	4	72.00	OHV	29-37/ 39-50			
Nova 1.2L i				01/85 → 10/89	187	BN040 (Fibre), 1.36mm (30-022712-20)	DH860■ (21-23271-21/0)	ET820 (22-20159-02/0)
Nova 1.2L N				01/85 → 10/87		BH860 (Fibre), 1.70mm (30-023271-20)	DN041■ (21-22712-26/0)	
12 NC	1196	4	79.00	Carburettor, OHV	33/45			
E 12 GV	1196	4	79.00	Injection	33/45			
Nova 1.2L i				09/89 → 03/93	188	BW170 (Fibre) (30-027215-00)	DW170 (21-27215-20/0)	ES260 [248] (22-27194-00/0)
C 12 NZ	1195	4	72.00	Injection, SOHC	33/45			
Nova 1.2L N				01/90 → 03/93	189	BL550 (Fibre) (30-024666-10)	DL551 (21-24666-23/0)	EK470 (22-27194-05/0)
Nova 1.2L S				01/88 → 02/90				
12 NV	1196	4	77.80	OHC	38/52			
Nova 1.2L S				09/82 → 02/90	190	BL550 (Fibre) (30-024666-10)	DL550 (21-24666-24/0) → 12/85 → Eng.19391636 DL551 (21-24666-23/0) 01/86 → Eng.eng.19391637 → →	EK470 (22-27194-05/0)
12 ST	1196	4	77.80	Carburettor, SOHC	40-43/ 54-58			
Nova 1.3L i				09/89 → 03/93	191	BK470 (Fibre) (30-024033-10) BH860 (Fibre), 1.70mm (30-023271-20)	DK471 (21-24033-30/0)	EK470 (22-27194-05/0)
C 13 N	1297	4	75.00	SPi, SOHC	44/60			
Nova 1.3L i				09/85 → 10/89	192	BK470 (Fibre) (30-024033-10)	DK471 (21-24033-30/0)	EK470 (22-27194-05/0)
13 NB	1297	4	75.00	Carburettor, SOHC	44/60			











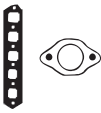

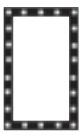

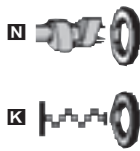























































































								
HBS011  (22-51004B) M12x1.25x160mm (x10) M12x1.25x119mm (x12)			JN969 (50-027678-00)					 AE5220  AY290, AY300, AY310  BK470  BL550  BN010  BN040, BH860  BW170  BX390, BX400, BX410, BX420
HBS373  (22-51110B) M12x1.50x131mm (x10)								 HC288  JH5005  JJ120  JJ519
HBS011  (22-51004B) M12x1.25x160mm (x10) M12x1.25x119mm (x12)	JC054  (x4) (31-024274-10) JC055  (x4) (31-025031-10)	JN956	JJ519 (31-025623-00)	HR602  24-30670-61/0	NF885  [3] 70x159x16mm, FPM (50-307266-70) NF883  [3] 114x171x13mm, FPM (50-307265-70)			
HBS112  (22-29006B) M9x1.25x80mm (x5) M9x1.25x100mm (x5)	JA499  JA415  (31-020165-10)	JN068 (31-023120-10) →12/84	HC288  (23-20161-01/0)	HR291  (50-024209-00)	NB691  54x82x9mm, ACM			 NB575 [2]  JA415  JA499  JC054  JC055
HBS112  (22-29006B) M9x1.25x80mm (x5) M9x1.25x100mm (x5)	JA499  JA415  (31-020165-10)	JN068 (31-023120-10)	HC288  (23-20161-01/0)	HR291  (50-024209-00)	NB691  54x82x9mm, ACM		NB575 [2]  JA415  JA499  JC054  JC055	
HBS002  (22-29098B) M10x1.25x140mm (x10)	JC824  (31-026334-00) JC281  (31-024312-10)	JN626 (31-026099-10)	JH5005 [116] (31-027194-00) JJ120	PA565 (x8) (50-305900-50) HR342  (24-30590-05/0)	NC006  35x48x7mm, MVQ (50-319161-00) NB697  26x42x8mm, FPM (50-306704-00) NB698  80x98x10mm, FPM (50-319273-00)			 JC280  JC281  JC824  JE119
HBS002  (22-29098B) M10x1.25x140mm (x10)	JC280  (31-024313-10) JC281  (31-024312-10)	JN626 (31-026099-10)	JH5005 [116] (31-027194-00) JJ120	PA565 (x8) (50-305900-50) HR342  (24-30590-05/0)	NC006  35x48x7mm, MVQ (50-319161-00) NB697  26x42x8mm, FPM (50-306704-00) NB698  80x98x10mm, FPM (50-319273-00)		NB575 [2]  JC280  JC281  JC824  JE119	
HBS002  (22-29098B) M10x1.25x140mm (x10)	JC280  (31-024313-10) JC281  (31-024312-10)	JN344 (31-024299-00) →12/85 →Eng.19391636 JN626 (31-026099-10) 01/86→ Eng.eng.1939163 7→→	JH5005 [116] (31-027194-00) JJ120	PA565 (x8) (50-305900-50) HR342  (24-30590-05/0)	NC006  35x48x7mm, MVQ (50-319161-00) NB697  26x42x8mm, FPM (50-306704-00) NB698  80x98x10mm, FPM (50-319273-00)		NB575 [2]  JC280  JC281  JC824  JE119	
HBS002  (22-29098B) M10x1.25x140mm (x10)	JC280  (31-024313-10) JC281  (31-024312-10)	JN626 (31-026099-10)	JH5005 [116] (31-027194-00) JJ120	PA565 (x8) (50-305900-50) HR342  (24-30590-05/0)	NC006  35x48x7mm, MVQ (50-319161-00) NB697  26x42x8mm, FPM (50-306704-00) NB698  80x98x10mm, FPM (50-319273-00)		NB575 [2]  JC280  JC281  JC824  JE119	
HBS002  (22-29098B) M10x1.25x140mm (x10)	JC280  (31-024313-10) JC281  (31-024312-10)  JE119 (31-024520-00)	JN626 (31-026099-10)	JH5005 [116] (31-027194-00) JJ120	PA565 (x8) (50-305900-50) HR342  (24-30590-05/0)	NC006  35x48x7mm, MVQ (50-319161-00) NB697  26x42x8mm, FPM (50-306704-00) NB698  80x98x10mm, FPM (50-319273-00)		NB575 [2]  JC280  JC281  JC824  JE119	



KW/PS



Nova 1.3L S					09/82 → 10/89	193	BK470 (Fibre) (30-024033-10)		DK470 (21-24033-26/0) → 12/85 DK471 (21-24033-30/0) 01/86 →	EK470 (22-27194-05/0)
13 SB	1297	4	75.00	SOHC		51/70				
Nova 1.4L i Nova 1.4L S					01/90 → 03/93	194	BS260 (Fibre) (30-026329-10)		DS260 (21-26329-21/0)	EK470 (22-27194-05/0)
C 14 NZ	1389	4	77.60	SPi, SOHC		44/60				
14 NV	1389	4	77.60	Carburettor, SOHC		53-55/ 72-75				
Nova 1.4L i S					09/91 → 03/93	195	BS260 (Fibre) (30-026329-10)		DS261 (21-26329-22/0)	ES260 [248] (22-27194-00/0)
C 14 SE	1389	4	77.60	Injection, SOHC		60/81				
Nova 1.5L D Diesel Nova 1.5L TD Diesel					09/87 → 03/93	196	AY840 (MLS), 1.40mm (30-028998-00) → Eng.975024 AY850 (MLS), 1.45mm, 1 Hole (30-028999-00) → Eng.975024 AY860 (MLS), 1.50mm, 2 Holes (30-029000-00) → Eng.975024 AY900 (MLS), 1.40mm (30-029007-00) Eng.975025 → AY910 (MLS), 1.45mm, 1 Hole (30-029006-00) Eng.975025 → AY920 (MLS), 1.50mm, 2 Holes (30-029008-00) Eng.975025 →		CY811 ▲ ■ (21-27776-22/0)	FY811 ▲ (20-27776-02/0)
15 D	1488	4	76.00	SOHC		37/50				
15 DT (T4EC1)	1488	4	76.00			49-53/ 67-72				
Nova 1.6L GSI					05/88 → 03/92	197	BP800 (Fibre) (30-025706-20)		DP802 (21-25706-25/0)	EK484 [129] (22-27194-01/0)
E 16 SE	1598	4	79.00	Injection		74/100				
Nova 1.6L GSI					09/89 → 03/93	198	BP800 (Fibre) (30-025706-20)		DP803	ES260 [248] (22-27194-00/0)
C 16 SEI	1598	4	79.00	Direct Injection, DOHC		72/98				
C 16 SE	1598	4	79.00	Injection, SOHC		74/100				
Novavan Van 1.2L					01/90 → 10/94	199	BL550 (Fibre) (30-024666-10)		DL551 (21-24666-23/0)	EK470 (22-27194-05/0)
12 NV	1196	4	77.80			38/52				







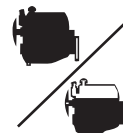



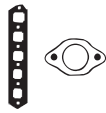

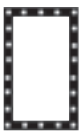

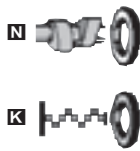



















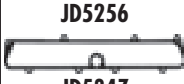





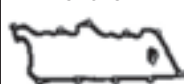







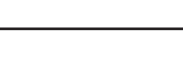
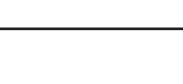









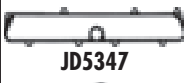









































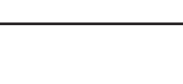



								
HBS002  [22-29098B] M10x1.25x140mm (x10)	JC280  (31-024313-10) JC281  (31-024312-10)  JE119 (31-024520-00)	JN344 (31-024299-00) →12/85 JN626 (31-026099-10) 01/86→	JH5005 [116] (31-027194-00) JJ120	PA565 (x8) (50-305900-50) HR342  (24-30590-05/0)	 NC006  35x48x7mm, MVQ (50-319161-00)  NB697  26x42x8mm, FPM (50-306704-00)  NB698  80x98x10mm, FPM (50-319273-00)	NB575 [2] 	 AY840, AY850, AY860  JH5058  AY900, AY910, AY920  JJ120  BK470  BL550  BP800  BS260  JC280  JC281  JC823  JC824  JD303  JD304  JE119  JE120  JN344  JN626  JN777  JN929  JH5005	
HBS002  [22-29098B] M10x1.25x140mm (x10)	JC824  (31-026334-00) JC281  (31-024312-10)	JN626 (31-026099-10)	JH5005 [116] (31-027194-00) JJ120	PA565 (x8) (50-305900-50) HR342  (24-30590-05/0)	 NC006  35x48x7mm, MVQ (50-319161-00)  NB697  26x42x8mm, FPM (50-306704-00)  NB698  80x98x10mm, FPM (50-319273-00)	NB575 [2] 		
HBS002  [22-29098B] M10x1.25x140mm (x10)	JC823  (31-027191-10) JC281  (31-024312-10)	JN929 (50-027192-10)	JH5005 [116] (31-027194-00) JJ120	PA565 (x8) (50-305900-50) HR342  (24-30590-05/0)	 NC006  35x48x7mm, MVQ (50-319161-00)  NB697  26x42x8mm, FPM (50-306704-00)  NB698  80x98x10mm, FPM (50-319273-00)			
HBS036  [22-29001B] M12x1.5x102mm (x10)	JD303  JD304   JE5029 (31-027779-00)	JN777 (50-027776-00)	JH5058 (31-027781-00)	PA658 (x8) (50-319265-00)	 NJ449  40x52x6mm, NBR (50-319266-00)  NJ449  40x52x6mm, NBR (50-319266-00)  NK103  87x100x8.5mm, FPM			
HBS002  [22-29098B] M10x1.25x140mm (x10)	JC824  (31-026334-00) JC281  (31-024312-10)  JE120 (31-024767-00)	JN626 (31-026099-10)	JH5005 (x2) [116] (31-027194-00) JJ120 (x2)	PA565 (x8) (50-305900-50) HR342  (24-30590-05/0)	 NC006  35x48x7mm, MVQ (50-319161-00)  NB697  26x42x8mm, FPM (50-306704-00)  NB698  80x98x10mm, FPM (50-319273-00)	NB575 [2] 		
HBS002  [22-29098B] M10x1.25x140mm (x10)	JC823  (31-027191-10) JC281  (31-024312-10)	JN929 (50-027192-10)	JH5005 [116] (31-027194-00)	PA565 (x8) (50-305900-50) HR342  (24-30590-05/0)	 NC006  35x48x7mm, MVQ (50-319161-00)  NB697  26x42x8mm, FPM (50-306704-00)  NB698  80x98x10mm, FPM (50-319273-00)			
HBS002  [22-29098B] M10x1.25x140mm (x10)	JC280  (31-024313-10) JC281  (31-024312-10)	JN626 (31-026099-10)	JH5005 [116] (31-027194-00) JJ120	PA565 (x8) (50-305900-50) HR342  (24-30590-05/0)	 NC006  35x48x7mm, MVQ (50-319161-00)  NB697  26x42x8mm, FPM (50-306704-00)  NB698  80x98x10mm, FPM (50-319273-00)	NB575 [2] 		



KW/PS



Novavan Van 1.5L D Diesel		01/91 → 10/94		200	AY840 (MLS), 1.40mm (30-028998-00) → Eng.975024 AY850 (MLS), 1.45mm, 1 Hole (30-028999-00) → Eng.975024 AY860 (MLS), 1.50mm, 2 Holes (30-029000-00) → Eng.975024 AY900 (MLS), 1.40mm (30-029007-00) Eng.975025 → AY910 (MLS), 1.45mm, 1 Hole (30-029006-00) Eng.975025 → AY920 (MLS), 1.50mm, 2 Holes (30-029008-00) Eng.975025 →	CY811 ▲ ■ (21-27776-22/0)	FY811 ▲ (20-27776-02/0)
15 D	1488	4	76.00	37/50			
Omega 2.0L		03/94 → 12/00		201	BP820 (Fibre) (30-025819-10)	DP820 (21-25819-21/0)	EK482 (22-26131-01/0)
20 SE	1998	4	86.00	90/122	Injection, SOHC		
Omega 2.0L		03/94 → 09/99		202	BP820 (Fibre) (30-025819-10)		EC130 (22-28793-00/0)
X 20 SE	1998	4	86.00	85/116	Injection, SOHC		
Omega 2.0L 16V		03/94 → 09/99		203	BY250 (Fibre) (30-027987-10)	DY250 (21-27987-20/0)	EC130 (22-28793-00/0) HC5007 [212] (22-28386-00/0)
X 20 XEV	1998	4	86.00	100/136	Injection, DOHC		
Omega 2.0L DTI 16V Diesel		10/98 → 09/00		204	AB5671 (MLS), 1.30mm, 1 Notch AB5681 (MLS), 1.40mm, 2 Notches	CB5670 ▲ ■ (21-29011-20/0)	EB5670 (22-29011-00/0)
X 20 DTH	1995	4	84.00	74/100	Direct Injection		
Omega 2.2L 16V		09/99 →		205	BY250 (Fibre) (30-027987-10)	DY253 (21-27987-22/0)	EC101 (22-27206-02/0)
Z 22 XE Y 22 XE	2198 2198	4 4	86.00 86.00	106/144 106- 108/ 144- 147	Injection, DOHC		
Omega 2.2L DTI 16V Diesel		09/00 →		206	AB5671 (MLS), 1.30mm, 1 Notch AB5681 (MLS), 1.40mm, 2 Notches	CB5670 ▲ ■ (21-29011-20/0)	EB5670 (22-29011-00/0)
Y 22 DTH	2172	4	84.00	85-88/ 116- 120	Direct Injection		











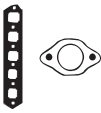

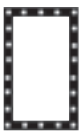

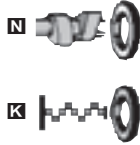

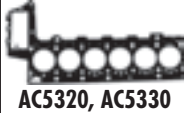





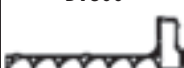









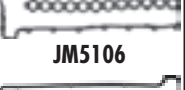

								
HBS036 Ⓢ [22-29001B] M12x1.5x102mm (x10)	JD303 ■ JD304 ■  JE5029 (31-027779-00)	JN777 (50-027776-00)	JH5058 (31-027781-00)	PA658 (x8) (50-319265-00)	 NJ449 ■ 40x52x6mm, NBR (50-319266-00)  NJ449 ■ 40x52x6mm, NBR (50-319266-00)  NK103 ■ 87x100x8.5mm, FPM			 AY840, AY850, AY860  JH5058  AY900, AY910, AY920  JJ385  BP820  JJ615  BY250  JJ616  JC282  JJ617  JC756  JJ617  JD303  JJ617  JD304  JJ617  JD451  JJ617  JD5255  JJ617  JD5256  JJ617  JD5347  JJ617  JE120  JJ617  JM5159  JJ617  JN693  JJ617  JN777  JJ617  JP016  JJ617 JP083 JJ617 JH5057 JJ617
HBS003 Ⓢ [22-29009B] M11x1.25x140mm (x10)	JC756 ■ (31-025820-20) JC282 ■ (31-024625-20)  JE120 (31-024767-00)	JN693 [128] (31-026198-10)	JJ385 (x2) [148] (50-026131-00)	PA565 (x8) (50-305900-50) HR342 ■ (24-305900-05/0)	 NC006 ■ 35x48x7mm, MVQ (50-319161-00)  NB700 ■ 31x50x8mm, FPM (50-306551-50)  NB806 ■ 90x104x11mm, FPM (50-306552-00)			 JJ385  JN693  JJ385  JN693  JJ385  JN693  JJ385  JN693  JJ385  JN693  JJ385  JN693
HBS003 Ⓢ [22-29009B] M11x1.25x140mm (x10) →12/96 HBS053 Ⓢ [22-29099B] M11x1.25x140mm (x10) 01/97→	JC282 ■ (31-024625-20)  JE120 (31-024767-00)	JP083	JJ615 (31-028793-00)	PA565 (x8) (50-305900-50) HR342 ■ (24-305900-05/0)	 NC006 ■ 35x48x7mm, MVQ (50-319161-00)  NB700 ■ 31x50x8mm, FPM (50-306551-50)  NB806 ■ 90x104x11mm, FPM (50-306552-00)			 JJ615  JP083  JJ615  JP083  JJ615  JP083  JJ615  JP083  JJ615  JP083
HBS054 Ⓢ [22-29013B] M11x1.25x105mm (x10)	JD451 ■ (31-027699-00) JD450 ■ (31-027684-00)  JE120 (31-024767-00)	JP016 (50-027683-00)	JJ615 (31-028793-00) JJ616 ■ [212] (31-028386-00) JJ617 ■ [212] (31-028385-00)	HR791 ■ 24-30614-76/0	 NC006 ■ (x2) 35x48x7mm, MVQ (50-319161-00)  NB700 ■ 31x50x8mm, FPM (50-306551-50)  NB806 ■ 90x104x11mm, FPM (50-306552-00)			 JJ615  JP016  JJ615  JP016  JJ615  JP016  JJ615  JP016
HBS298 Ⓢ [22-29016B] M12x1.50x235mm (x10)	JD5255 ■ (31-029721-00) JD5347 ■ ■ (31-029942-00) JD5256 ■ (31-029722-00)	JM5159 (50-029633-00)	JH5057 (31-029575-00)	HR791 ■ 24-30614-76/0	 NA5069 ■ 55x68x8mm, FPM (50-319515-00)  NA5209 ■ 99x114x11mm, FPM (50-319514-00)			 JH5057  JM5159  JH5057  JM5159  JH5057  JM5159
HBS054 Ⓢ [22-29013B] M11x1.25x105mm (x10)	JD450 ■ (31-027684-00) JD5300 ■ (31-027684-10) (MLS)	JP016 (50-027683-00)	JH5119 (31-030116-00)	HR791 ■ 24-30614-76/0	 NC006 ■ (x2) 35x48x7mm, MVQ (50-319161-00)  NB700 ■ 31x50x8mm, FPM (50-306551-50)  NB806 ■ 90x104x11mm, FPM (50-306552-00)			 JH5119  JP016  JH5119  JP016
HBS298 Ⓢ [22-29016B] M12x1.50x235mm (x10)	JD5255 ■ (31-029721-00) JD5347 ■ ■ (31-029942-00) JD5256 ■ (31-029722-00)	JM5159 (50-029633-00)	JH5057 (31-029575-00)	HR791 ■ 24-30614-76/0	 NA5069 ■ 55x68x8mm, FPM (50-319515-00)  NA5209 ■ 99x114x11mm, FPM (50-319514-00)			 JH5057  JM5159  JH5057  JM5159

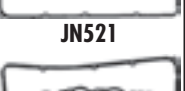

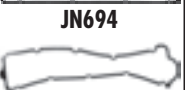
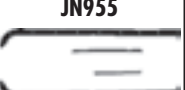
KW/PS



Model		Fuel		Period		Power	Code	Accessories
Omega 2.5L DTI 24V Diesel				09/01 →		207	AC5320 (MLS), 1.45mm, 1 Hole 30-028800-00 AC5330 (MLS), 1.55mm, 2 Holes 30-028801-00 AC5340 (MLS), 1.65mm, 3 Holes 30-028802-00 AB5980 (MLS), 1.80mm 30-029183-00	DZ660 ▲■ 21-29149-20/0
Y 25 DT	2497	6	80.00	Direct Injection, DOHC, V6		110/150		
Omega 2.5L TD Diesel				04/94 → 02/01		208	BZ110 (Fibre), 1.68mm, 2 Holes 30-027395-20 BZ120 (Fibre), 1.87mm, 3 Holes 30-027396-20	DW731 ▲■ 21-27179-22/0 EY280 22-27096-02/0
25 DT	2497	6	80.00	Injection, DOHC		96/130		
X 25 DT	2497	6	80.00	Indirect Injection, SOHC		96/131		
Omega 2.5L V6				03/94 → 09/00		209	BY270 (Fibre) (x2) (30-027690-00)	DY271 (21-27690-21/0) EY300
X 25 XE	2498	6	81.60	Injection, DOHC, V6		125-143/ 170-194		
Omega 2.6L V6				09/00 →		210		
Y 26 SE	2597	6	83.20	Injection, DOHC, V6		125-132/ 170-180		
Omega 3.0L V6				04/94 →		211	BY300 (Fibre) (30-027849-00)	DY300 (21-27849-20/0)
X 30 XE	2962	6	86.00	MPi, DOHC, V6		148-155/ 201-211		
Omega 3.2L V6				02/01 →		212		
Y 32 SE	3175	6	87.50	Injection, DOHC, V6		160/218		
Royale 2.2L E				11/84 → 08/87		213	BJ170 (Fibre) (30-025662-10)	DJ172 (21-25662-27/0)
22 E	2197	4	95.00	Injection, CIH		85/116		
Royale 2.2L TD Diesel				11/84 → 08/87		214	BR010 (Fibre), 1.30mm, 1 Hole (30-025657-10) BR020 (Fibre), 1.40mm, 2 Holes (30-025658-10) BR030 (Fibre), 1.50mm, 3 Holes (30-025659-10)	DR012 ▲■ (21-24240-23/0) EJ161
23 TD	2260	4	92.00	SOHC		63/86		
Senator 2.5L i				09/87 → 10/90		215	BT530 (Fibre) (30-026239-10) Eng.25E45755 →	EW870 (22-21235-00/0)
25 E	2490	6	87.00	L-Jetronic, CIH		96-103/ 130-140		
Senator 2.6L i				09/90 → 09/93		216	BT530 (Fibre) (30-026239-10)	
C 26 NE	2594	6	88.80	Injection, SOHC		110/150		
Senator 3.0L 24V				09/89 → 09/93		217	BV950 (Fibre) (30-027397-00)	DV951 EB950 (22-27392-00/0)
C 30 SE	2969	6	95.00	Injection, DOHC		150/204		











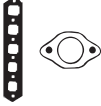

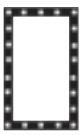

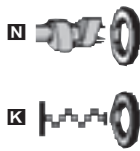





















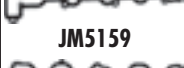









































									
HBS066 ® (22-11005B) M12x1.50x146.5mm (x14)	JD5108 ■ (50-029152-00) JD5107 ■ ■ (50-029153-00) JD5183 ■ (31-029124-00)	JM5106 50-029149-00		PA5016 (x24) 50-307240-70				 AB5980  AC5320, AC5330  AC5340  BR010, BR020, BR030  BT530  BV950  BY270  BY300  BZ110, BZ120  JD274  JD276  JD459  JD5107  JD5108  JD5134  JD5183  JD5202  JD5203  JD5204	JM5094  JM5094  JM5095  JM5106  JM956  JN041  JN521  JN523  JN694  JN955  HC295  HC417  JJ536  JJ572  JJ573
HBS066 ® (22-11005B) M12x1.50x146.5mm (x14)	JD274 ■ (x6) 31-027183-00 JD276 ■ [274] 31-027181-00 JD5134 ■ (x4) (31-029321-00)	JN955 50-027179-00	JJ536 (31-027096-20)	HR280 ■ 24-30614-75/0	■ NF637 ■ 48x65x10mm, FPM (50-306222-50) ■ NB431 ■ 90x110x12mm, FPM (50-306091-50)				
HBS164 ® (22-29011B) M11x1.25x105mm (x16)	JD5202 ■ (x2) (50-027980-00) JD5203 ■ ■ (x3) (50-027979-00) JD459 ■ (x2) (31-027698-00)	JM5095 ■ (50-027697-00) JM5094 ■ (50-027696-00) HM5294 ■ (24-27696-00/0)	JJ573 ■ (50-027851-00) JJ572 ■ (50-027852-00)	HR5062 ■ 24-30614-73/0	■ NC006 (x4) 35x48x7mm, MVQ (50-319161-00) ■ NB884 ■ 38x50x5.5mm, FPM (50-319010-00) ■ NB806 ■ 90x104x11mm, FPM (50-306552-00)				
HBS164 ® (22-29011B) M11x1.25x105mm (x16)	JD5202 ■ (x2) (50-027980-00) JD5203 ■ ■ (x3) (50-027979-00)	JD5204 (x2) (50-028690-00)		HR5062 ■ 24-30614-73/0	■ NC006 (x4) 35x48x7mm, MVQ (50-319161-00) ■ NB884 ■ 38x50x5.5mm, FPM (50-319010-00) ■ NB806 ■ 90x104x11mm, FPM (50-306552-00)				
HBS164 ® (22-29011B) M11x1.25x105mm (x16)	JD5202 ■ (50-027980-00) JD5203 ■ ■ (x3) (50-027979-00) JD459 ■ (x2) (31-027698-00)	JM5095 ■ (50-027697-00) JM5094 ■ (50-027696-00) HM5294 ■ (24-27696-00/0)	JJ573 ■ (50-027851-00) JJ572 ■ (50-027852-00)	HR5062 ■ 24-30614-73/0	■ NC006 (x4) 35x48x7mm, MVQ (50-319161-00) ■ NB884 ■ 38x50x5.5mm, FPM (50-319010-00) ■ NB806 ■ 90x104x11mm, FPM (50-306552-00)				
HBS164 ® (22-29011B) M11x1.25x105mm (x16)									
HBS161 ® (22-29007B) M12x1.50x64mm (x5) M12x1.50x97.5mm (x5)		JN041 (31-022926-10)	HC417 ■ (23-21237-01/0)		■ NB628 ■ 45x60x9mm, ACM (50-305272-00) ■ NB469 ■ 77x100x11.5mm, FPM (50-306260-50)				
HBS160 ® (22-29004B) M13x1.50x134mm (x10)		JN521 (31-023007-10) JN523	HC417 ■ (23-21237-01/0)		■ NB628 ■ 45x60x9mm, ACM (50-305272-00) ■ NB690 ■ 81x100.1x11.5mm, FPM (50-319087-00)				
		JM956 (31-022399-10) →Eng.25E45754 JN694 (50-026098-00) Eng.25E45755→	HC295 ■ (23-21243-01/0)	HR336 ■ (x3) (24-30656-05/0)	■ NB628 ■ 45x60x9mm, ACM (50-305272-00) ■ NB469 ■ 77x100x11.5mm, FPM (50-306260-50)				
		JN694 (50-026098-00)	HC295 ■ (23-21243-01/0) HC5008 ■	HR336 ■ (x3) (24-30656-05/0)	■ NB628 ■ 45x60x9mm, ACM (50-305272-00) ■ NB469 ■ 77x100x11.5mm, FPM (50-306260-50)				
HBS417 (22-29026B) M12x1.50x88mm (x14)			JJ508 (50-027392-00)	PA565 (x24) (50-305900-50) HR342 ■ (x3) (24-305900-50/0)					



KW/PS



Signum 1.9L CDTI Diesel				04/04 →	218	AA5570 (MLS), 0.92mm, 1 Hole (30-029094-10) AA5580 (MLS), 1.02mm, 2 Holes (30-029095-10)	CG7390▲ (21-30144-00/0)	EE5181 (22-29832-01/0)
Z 19 DT	1910	4	82.00	Direct Injection	74-88/ 100- 120			
Signum 1.9L CDTI 16V Diesel				04/04 →	219	AD5840 (MLS), 0.82mm, 0 Holes (30-029766-00) AD5850 (MLS), 0.92mm, 1 Hole (30-029767-00) AD5860 (MLS), 1.02mm, 2 Holes (30-029768-00)	CD5840▲ (21-29766-20/0)	EE5181 (22-29832-01/0)
Z 19 DTH	1910	4	82.00	Direct Injection	110/150			
Signum 2.0L DTI Diesel				05/03 →	220	AB5671 (MLS), 1.30mm, 1 Notch AB5681 (MLS), 1.40mm, 2 Notches	CB5671▲■ (21-29011-21/0)	EB5670 (22-29011-00/0)
Y 20 DTH	1995	4	84.00	Direct Injection	74/100			
Signum 2.2L DTI Diesel				05/03 →	221	AB5671 (MLS), 1.30mm, 1 Notch AB5681 (MLS), 1.40mm, 2 Notches	CB5671▲■ (21-29011-21/0)	EB5670 (22-29011-00/0)
Y 22 DTR	2172	4	84.00	Direct Injection	92/125			
Signum 2.2L i				05/03 →	222	AG9590 (MLS) (30-030345-00)	CG9590 (21-30345-00/0)	
Z 22 YH	2198	4	86.00	Injection	114/155			
Signum 3.0L CDTi Diesel				05/03 →	223	AG9770 (MLS), 0.60mm, 1 Hole AG9780 (MLS), 0.65mm, 2 Holes AG9790 (MLS), 0.70mm, 3 Holes AG9800 (MLS), 0.60mm, 1 Hole AG9810 (MLS), 0.65mm, 2 Holes AG9820 (MLS), 0.70mm, 3 Holes	CG9770▲	EG9770 FG9770▲
Signum 3.0L V6 CDTi Diesel				09/05 →				
Y 30 DT	2958	6	87.50	Direct Injection, V6	130/177			
Z 30 DT	2958	6	87.50	Direct Injection, V6	135/184			
Signum 3.2L V6				05/03 →	224			
Z 32 SE	3175	6	88.50	Injection, DOHC, V6	155/211			
Sintra 2.2L DTI Diesel				07/97 → 04/99	225	AB5671 (MLS), 1.30mm, 1 Notch AB5681 (MLS), 1.40mm, 2 Notches	CB5670▲■ (21-29011-20/0)	EB5670 (22-29011-00/0)
X 22 DTH	2172	4	84.00	Direct Injection	85/116			
Sintra 2.2L i 16 V				11/96 → 04/99	226	BY250 (Fibre) (30-027987-10)	DY251 (21-27987-21/0)	EC100 (22-27206-01/0)
X 22 XE	2198	4	86.00	Injection, DOHC	100/136			
Sintra 3.0L i 24V				11/96 → 04/99	227	BY300 (Fibre) (30-027849-00)	DY300 (21-27849-20/0)	
X 30 XE	2962	6	86.00	MPi, DOHC, V6	148- 155/ 201- 211			

								 AA5570, AA5580  JJ573
HBS227  [22-170188] M12x1.25x218mm (x10) HBS370  [22-17026B] M12x1.25x225mm (x10)	JD468  [31-028377-00] (MLS)	JM5204 [50-029935-00]		HR363 	NA5053 30x42x7mm, FPM [50-319488-00] NA5070 31x41x7mm, FPM [50-319524-00]	HL5031 [245] 		BY250  BY300  JD451  JD459  JD468  JD5202  JD5203  JD5255  JD5256  JD5277  JD5347  JD5376  JM5094  JM5095  JM5159  JM5204  JP016  JH5057  JJ459  JJ572 
HBS370  [22-17026B] M12x1.25x225mm (x10)	JD5376  [31-029969-00]	JM5204 [50-029935-00] JM7055 (Steel Elastomer)		HR363  HR5095 	NA5053 30x42x7mm, FPM [50-319488-00] NA5070 31x41x7mm, FPM [50-319524-00]	HL5031 [245] 		
HBS298  [22-29016B] M12x1.50x235mm (x10)	JD5255  [31-029721-00] JD5277  [31-029723-00] JD5256  [31-029722-00]	JM5159 [50-029633-00]	JH5057 [31-029575-00]	HR791  24-30614-76/0	NA5069 55x68x8mm, FPM [50-319515-00] NA5209 99x114x11mm, FPM [50-319514-00]	HL5031 [245] 		
HBS298  [22-29016B] M12x1.50x235mm (x10)	JD5255  [31-029721-00] JD5277  [31-029723-00] JD5256  [31-029722-00]	JM5159 [50-029633-00]	JH5057 [31-029575-00]	HR791  24-30614-76/0	NA5069 55x68x8mm, FPM [50-319515-00] NA5209 99x114x11mm, FPM [50-319514-00]			
HBS416  [22-29025B] M11x1.50x163mm (x10)	JD5869  (x3) [31-030358-00] JD5870  [31-030359-00] JD5868  [31-030346-00]		HR397 [57] 34-000410-00		NA5108 42x55x7mm, FPM [50-319392-00] NB806 90x104x11mm, FPM [50-306552-00]			
	JD5897  (Steel Elastomer) JD5896  JE5064  (Steel)	HM5278  24-30168-00/0 HM5292 		HR5094 				
HBS164  [22-29011B] M11x1.25x105mm (x16)			HR397 [57] 34-000410-00	HR280  (x2) 24-30614-75/0	NC006 (x4) 35x48x7mm, MVQ [50-319161-00] NB884 38x50x5.5mm, FPM [50-319010-00] NB806 90x104x11mm, FPM [50-306552-00]			
HBS298  [22-29016B] M12x1.50x235mm (x10)	JD5255  [31-029721-00] JD5347  [31-029942-00] JD5256  [31-029722-00]	JM5159 [50-029633-00]	JH5057 [31-029575-00]	HR791  24-30614-76/0	NA5069 55x68x8mm, FPM [50-319515-00] NA5209 99x114x11mm, FPM [50-319514-00]			
HBS054  [22-29013B] M11x1.25x105mm (x10)	JD451  [31-027699-00] JD450  [31-027684-00]	JP016 [50-027683-00]	JJ459 [148] [31-027206-00]	HR791  24-30614-76/0	NC006 (x2) 35x48x7mm, MVQ [50-319161-00] NB700 31x50x8mm, FPM [50-306551-50] NB806 90x104x11mm, FPM [50-306552-00]			
HBS164  [22-29011B] M11x1.25x105mm (x16)	JD5202  [50-027980-00] JD5203  (x3) [50-027979-00] JD459  (x2) [31-027698-00]	JM5095  [50-027697-00] JM5094  [50-027696-00] HM5294  [24-27696-00/0]	JJ573  [50-027851-00] JJ572  [50-027852-00]	HR5062  24-30614-73/0	NC006 (x4) 35x48x7mm, MVQ [50-319161-00] NB884 38x50x5.5mm, FPM [50-319010-00] NB806 90x104x11mm, FPM [50-306552-00]			









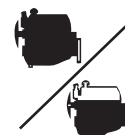



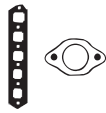

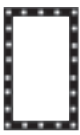

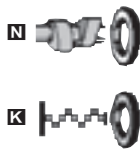



























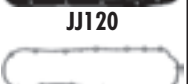

cc



KW/PS



Tigra 1.3L CDTI Diesel		06/04 →		228	AD5800 (MLS), 0.72mm (30-029762-00) AD5810 (MLS), 0.82mm, 1 Hole (30-029763-00) AD5820 (MLS), 0.92mm, 2 Holes (30-029764-00)	CD5800▲ (21-29762-20/0)
Z 13 DT	1248	4	69.80	Direct Injection	51/70	
Tigra 1.4L		06/04 →		229	AH5030 (MLS) (30-030366-00)	CH5030 (21-30366-00/0)
Z 14 XEP	1364	4	73.40	Injection, DOHC	66/89	
Tigra Coupe 1.4L 16V		07/94 →		230	AY210 (Fibre) (30-027985-00)	CY210 (21-27985-21/0)
X 14 XE	1389	4	77.60	Injection, DOHC	66/89	EY230 (22-27665-01/0)
Tigra Coupe 1.6L 16V		07/94 →		231	AY220 (Fibre)	CY220 (21-27986-21/0)
X 16 XE	1598	4	79.00	Injection, DOHC	78/106	EY230 (22-27665-01/0)
Tigra 1.8L		06/04 →		232	AC5460 (MLS) (30-028674-00)	CC5460 (21-28674-20/0)
Z 18 XE	1799	4	80.50	Injection, DOHC	87-92/ 118- 125	
Vectra 1.6L		01/06 →		233	AB5540 (MLS) (30-029209-00)	CB5540 (21-29209-20/0)
Z 16 XEP	1598	4	79.00	Injection, DOHC	74-77/ 101- 105	EB5541 [8] (22-27665-03/0)
Vectra 1.6L i		10/95 →		234	BP800 (Fibre) (30-025706-20)	DP806 (21-25706-30/0)
X 16 SZR	1598	4	79.00	SPi, SOHC	55/75	
Vectra 1.6L i 16V		10/95 →		235	AB5540 (MLS) (30-029209-00) Y16XE, Z16SE AY220 (Fibre) X16XEL	CB5540 (21-29209-20/0) Y16XE, Z16SE CY221 (21-27986-22/0) →12/97 X16XEL DY232 (21-27986-25/0) 01/98 → X16XEL
Z 16 XE	1598	4	79.00	Injection, DOHC	63-74/ 85-101	EY230 (22-27665-01/0) →Eng.02MB4997
X 16 XEL	1598	4	79.00	Injection, DOHC	74/100	→Eng.20R22448
Y 16 XE	1598	4	79.00		74/100	EB5541 [8] (22-27665-03/0) Eng.02MB4998 → Eng.20R22449 →











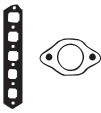

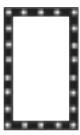

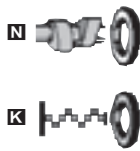

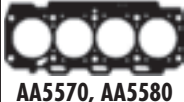

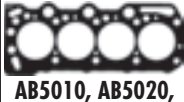

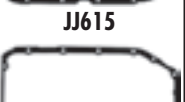
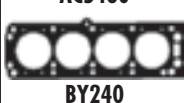



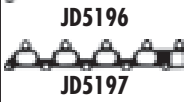

								
HBS353 ® (22-17025B) M10x1.25x119mm (x10)	JD5411 ■ (50-030025-00) JD5412 ■ ■ (50-030026-00) JD5413 ■ (31-030027-00) (MLS)	JM5259 (31-030023-00)		HR5088 ■ (24-31952-10/0)	NA5223 ■ 40x52x7mm, FPM (50-319520-00) NA5230 ■ 78x100x9mm, PTFE (50-319522-00)	KK5646 [45]		 AB5540  AC5460  AD5800  AD5810  AD5820  AY210  AY220  BP800  JC281  JC824  JD444  JD445  JD448  JD5147  JD5148  JD5196  JD5197  JD5229  JD5269  JD5412 JE5024
HBS252 ® (22-29014B) M8x1.25x119mm (x12)	JD5904 ■ (x4) (50-030368-00) (FPM) JE5024 ■ (31-029170-00)	JM5071 (50-029232-00)	JH5036 (31-029169-00)	HR5048 ■ (24-31938-60/0)	NA5108 ■ 42x55x7mm, FPM (50-319392-00) NB698 ■ 80x98x10mm, FPM (50-319273-00)	JR5030 [11]		 JM5059  JM5092  JM5235  JN929  JP008  JP009  JH5005  JH5036  JJ120  JJ575
HBS055 ® (22-29012B) M10x1.25x153mm (x10)	JD5269 ■ (31-027984-00) JD445 ■ ■ (31-027881-00) JD444 ■ (31-027878-00)	JP009 ■ (50-027983-00) JP008 ■ (50-027982-00)	JJ575 [148] (50-027665-00)	HR791 ■ 24-30614-76/0	NC006 ■ (x2) 35x48x7mm, MVQ (50-319161-00) NB697 ■ 26x42x8mm, FPM (50-306704-00) NB698 ■ 80x98x10mm, FPM (50-319273-00)			 JM5092  JM5235
HBS055 ® (22-29012B) M10x1.25x153mm (x10)	JD448 ■ (31-027880-00) JD445 ■ ■ (31-027881-00) JD444 ■ (31-027878-00)	JP009 ■ (50-027983-00) JP008 ■ (50-027982-00)	JJ575 [148] (50-027665-00)	HR791 ■ 24-30614-76/0	NC006 ■ (x2) 35x48x7mm, MVQ (50-319161-00) NB697 ■ 26x42x8mm, FPM (50-306704-00) NB698 ■ 80x98x10mm, FPM (50-319273-00)			 JM5092  JM5235
HBS055 ® (22-29012B) M10x1.25x153mm (x10)	JD5196 ■ (31-029039-00) JD5197 ■ (31-029040-00)	JM5092 (50-029087-00)		HR5048 ■ (24-31938-60/0)	NC006 ■ (x2) 35x48x7mm, MVQ (50-319161-00) NC065 ■ 30x40x7mm, FPM (50-306142-00) NB698 ■ 80x98x10mm, FPM (50-319273-00)			 JM5092  JM5235
HBS055 ® (22-29012B) M10x1.25x153mm (x10)	JD5147 ■ (31-029203-00) JD5148 ■ (31-029204-00)	JM5059 (50-029202-00) JM5235 (50-029985-00)		HR791 ■ 24-30614-76/0	NC006 ■ (x2) 35x48x7mm, MVQ (50-319161-00) NB697 ■ 26x42x8mm, FPM (50-306704-00) NB698 ■ 80x98x10mm, FPM (50-319273-00)			 JM5092  JM5235
HBS002 ® (22-29098B) M10x1.25x140mm (x10)	JC824 ■ (31-026334-00) JC281 ■ (31-024312-10)	JN929 (50-027192-10)	JH5005 [116] (31-027194-00) JJ120	PA565 (x8) (50-305900-50) HR342 ■ (24-305900-05/0)	NC006 ■ 35x48x7mm, MVQ (50-319161-00) NB697 ■ 26x42x8mm, FPM (50-306704-00) NB698 ■ 80x98x10mm, FPM (50-319273-00)			 JM5092  JM5235
HBS055 ® (22-29012B) M10x1.25x153mm (x10)	JD5269 ■ (31-027984-00) →12/97 X16XEL JD5229 ■ ■ (31-028463-00) →12/97 X16XEL JD5147 ■ (31-029203-00) 01/98 → JD444 ■ (31-027878-00) X16XEL JD5148 ■ (31-029204-00) Y16XE, Z16SE	JP009 ■ (50-027983-00) →12/97 JP008 ■ (50-027982-00) →12/97 JM5059 (50-029202-00) 01/98 →	JJ575 [148] (50-027665-00) →Eng.02MB4997 →Eng.20R22448	HR791 ■ 24-30614-76/0	NC006 ■ (x2) 35x48x7mm, MVQ (50-319161-00) NB697 ■ 26x42x8mm, FPM (50-306704-00) NB698 ■ 80x98x10mm, FPM (50-319273-00)			 JM5092 JM5235



KW/PS



Vauxhall Model				Year Range	Code	Part Description	Part Code	Part Description
Vectra 1.7L TD Diesel				10/95 → 11/96	236	AB5010 (MLS), 1.40mm (30-029163-00) AB5020 (MLS), 1.45mm, 1 Hole (30-029164-00) AB5030 (MLS), 1.50mm, 2 Holes (30-029165-00)	CY811 ▲■ (21-27776-22/0)	FY811 ▲ (20-27776-02/0)
X 17 DT (TC4EE1)	1686	4	79.00		60/81			
Vectra 1.8L 16V				04/02 →	237	AC5460 (MLS) (30-028674-00)	CC5460 (21-28674-20/0)	
Vectra 1.8L 16V Dualfuel				04/02 →				
Vectra 1.8L i 16V				09/00 →				
Z 18 XE	1799	4	80.50	Injection, DOHC	87-92/ 118- 125			
Vectra 1.8L i 16V				10/95 → 09/00	238	AC5460 (MLS) (30-028674-00) X18XE1 BY240 (Fibre) (30-027682-00) X18XE	CC5460 (21-28674-20/0) X18XE1 DY240 (21-27682-21/0) X18XE	EC130 (22-28793-00/0) X18XE HC5007 [212] (22-28386-00/0) X18XE
X 18 XE1	1796	4	80.50	Injection, DOHC	85/116			
X 18 XE	1799	4	81.60	Injection, DOHC	85/116			
Vectra 1.9L CDTI Diesel				04/04 →	239	AA5570 (MLS), 0.92mm, 1 Hole (30-029094-10) AA5580 (MLS), 1.02mm, 2 Holes (30-029095-10)	CG7390 ▲ (21-30144-00/0)	EE5181 (22-29832-01/0)
Z 19 DT	1910	4	82.00	Direct Injection	74-88/ 100- 120			
Vectra 1.9L CDTI 16V Diesel				04/04 →	240	AD5840 (MLS), 0.82mm, 0 Holes (30-029766-00) AD5850 (MLS), 0.92mm, 1 Hole (30-029767-00) AD5860 (MLS), 1.02mm, 2 Holes (30-029768-00)	CD5840 ▲ (21-29766-20/0)	EE5181 (22-29832-01/0)
Z 19 DTH	1910	4	82.00	Direct Injection	110/150			
Vectra 2.0L DI 16V Diesel				11/96 →	241	AB5671 (MLS), 1.30mm, 1 Notch AB5681 (MLS), 1.40mm, 2 Notches	CB5670 ▲■ (21-29011-20/0)	EB5670 (22-29011-00/0)
X 20 DTL	1995	4	84.00	Direct Injection	60/81			
Vectra 2.0L DTi 16V Diesel				06/97 →	242	AB5671 (MLS), 1.30mm, 1 Notch AB5681 (MLS), 1.40mm, 2 Notches	CB5670 ▲■ (21-29011-20/0) X20DTH CB5671 ▲■ (21-29011-21/0) Y20DTH	EB5670 (22-29011-00/0)
X 20 DTH/Y 20 DTH	1995	4	84.00	Direct Injection	74/100			
Vectra 2.0L DTi 16V Diesel				04/02 →	243	AB5671 (MLS), 1.30mm, 1 Notch AB5681 (MLS), 1.40mm, 2 Notches	CB5671 ▲■ (21-29011-21/0)	EB5670 (22-29011-00/0)
Y 20 DTH	1995	4	84.00	Direct Injection	74/100			
Y 20 DTH	1995	4	84.00		74/101			











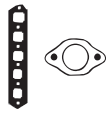

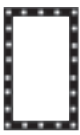

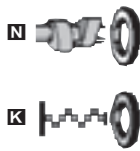

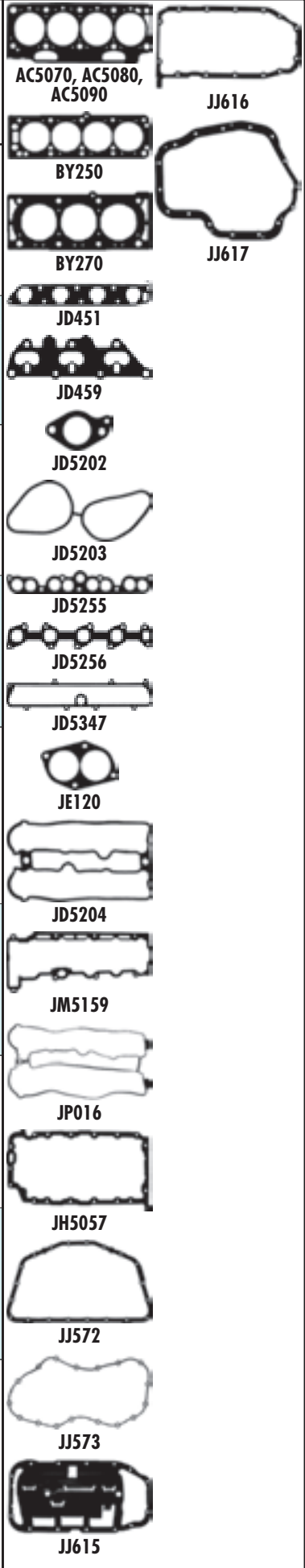







































































								
HBS036 ® (22-29001B) M12x1.5x102mm (x10)	JD303 ■ JD304 ■ ⊙ JE5029 (31-027779-00)	JN777 (50-027776-00)		PA658 (x8) (50-319265-00)	NJ449 40x52x6mm, NBR (50-319266-00) NJ449E 40x52x6mm, NBR (50-319266-00) NK103 ■ 87x100x8.5mm, FPM			 AA5570, AA5580  JH5057  AB5010, AB5020, AB5030  JJ615  AC5460  JJ616  BY240  JD303  JD304  JJ617  JD451  JD468  JD5196  JD5197  JD5255  JD5256  JD5277  JD5347  JD5376  JE120  JM5092  JM5159  JM5204  JN777 JP016
HBS055 ⊙ (22-29012B) M10x1.25x153mm (x10)	JD5196 ■ (31-029039-00) JD5197 ■ (31-029040-00)	JM5092 (50-029087-00)		HR5048 ■ (24-31938-60/0)	NC006 ■ (x2) 35x48x7mm, MVQ (50-319161-00) NC065 ■ 30x40x7mm, FPM (50-306142-00) NB698 ■ 80x98x10mm, FPM (50-319273-00)			
HBS054 ⊙ (22-29013B) M11x1.25x105mm (x10) X18XE HBS055 ⊙ (22-29012B) M10x1.25x153mm (x10) X18XE1	JD451 ■ (31-027699-00) X18XE JD5196 ■ (31-029039-00) X18XE1 JD450 ■ (31-027684-00) X18XE JD5197 ■ (31-029040-00) X18XE1 ⊙ JE120 (31-024767-00) X18XE	JM5092 (50-029087-00) X18XE1 JP016 (50-027683-00) X18XE	HR397 [57] 34-000410-00 X18XE1 JJ615 (31-028793-00) X18XE JJ616 ■ [212] (31-028386-00) X18XE JJ617 ■ [212] (31-028385-00) X18XE	HR5048 ■ (24-31938-60/0) X18XE1 HR791 ■ 24-30614-76/0 X18XE	NC006 ■ (x2) 35x48x7mm, MVQ (50-319161-00) NC065 ■ 30x40x7mm, FPM (50-306142-00) X18XE1 NB700 ■ 31x50x8mm, FPM (50-306551-50) X18XE NB698 ■ 80x98x10mm, FPM (50-319273-00) X18XE1 NB806 ■ 90x104x11mm, FPM (50-306552-00) X18XE			
HBS227 ⊙ (22-17018B) M12x1.25x218mm (x10)	JD468 ■ (31-028377-00) (MLS)	JM5204 (50-029935-00)		HR363 ■	NA5053 30x42x7mm, FPM (50-319488-00) NA5070 ■ 31x41x7mm, FPM (50-319524-00)	HL5031 [245]■		
HBS370 ⊙ (22-17026B) M12x1.25x225mm (x10)	JD5376 ■ (31-029969-00)	JM5204 (50-029935-00) JM7055 (Steel Elastomer)		HR363 ■ HR5095 ■	NA5053 30x42x7mm, FPM (50-319488-00) NA5070 ■ 31x41x7mm, FPM (50-319524-00)	HL5031 [245]■		
HBS298 ⊙ (22-29016B) M12x1.50x235mm (x10)	JD5255 ■ (31-029721-00) JD5347 ■ ■ (31-029942-00) JD5256 ■ (31-029722-00)	JM5159 (50-029633-00)	JH5057 (31-029575-00)	HR791 ■ 24-30614-76/0	NA5069 ■ 55x68x8mm, FPM (50-319515-00) NA5209 ■ 99x114x11mm, FPM (50-319514-00)			
HBS298 ⊙ (22-29016B) M12x1.50x235mm (x10)	JD5255 ■ (31-029721-00) JD5277 ■ ■ (31-029723-00) Y20DTH JD5347 ■ ■ (31-029942-00) X20DTH JD5256 ■ (31-029722-00)	JM5159 (50-029633-00)	JH5057 (31-029575-00)	HR791 ■ 24-30614-76/0	NA5069 ■ 55x68x8mm, FPM (50-319515-00) NA5209 ■ 99x114x11mm, FPM (50-319514-00)			
HBS298 ⊙ (22-29016B) M12x1.50x235mm (x10)	JD5255 ■ (31-029721-00) JD5277 ■ ■ (31-029723-00) JD5256 ■ (31-029722-00)	JM5159 (50-029633-00)	JH5057 (31-029575-00)	HR791 ■ 24-30614-76/0	NA5069 ■ 55x68x8mm, FPM (50-319515-00) NA5209 ■ 99x114x11mm, FPM (50-319514-00)			



KW/PS



Vectra 2.0L i 16V		10/95 → 09/00		244		BY250 (Fibre) [30-027987-10]	DY250 (21-27987-20/0)	EC130 (22-28793-00/0) HC5007 [212] (22-28386-00/0)
X 20 XEV	1998	4	86.00	Injection, DOHC	100/136			
Vectra 2.2L 16V		04/02 →		245		AG9580 (MLS) [30-030344-00]	CG9580 (21-30344-00/0)	
Vectra 2.2L i 16V		09/00 →						
Z 22 SE	2198	4	86.00	Injection, DOHC	108/147			
Vectra 2.2L direct		10/03 →		246		AG9590 (MLS) [30-030345-00]	CG9590 (21-30345-00/0)	
Z 22 YH	2198	4	86.00	Injection	114/155			
Vectra 2.2L DTI 16V Diesel		09/00 →		247		AB5671 (MLS), 1.30mm, 1 Notch AB5681 (MLS), 1.40mm, 2 Notches	CB5670▲■ (21-29011-20/0)	EB5670 (22-29011-00/0)
Y 22 DTR	2172	4	84.00	Direct Injection	92/125			
Y 22 DTR	2172	4	84.00		92/125			
Vectra 2.5L i GSi		05/98 → 09/99		248		BY270 (Fibre) (x2) [30-027690-00]	DY272 (21-27690-22/0)	EY300
Vectra 2.5L i V6		10/95 → 09/00						
X 25 XE	2498	6	81.60	Injection, DOHC, V6	125- 143/ 170- 194			
Vectra 2.6L i V6		09/00 →		249				
Y 26 SE	2597	6	83.20	Injection, DOHC, V6	125- 132/ 170- 180			
Vectra 3.0L CDTi Diesel		08/05 →		250		AG9770 (MLS), 0.60mm, 1 Hole ☒ AG9780 (MLS), 0.65mm, 2 Holes ☒ AG9790 (MLS), 0.70mm, 3 Holes ☒ AG9800 (MLS), 0.60mm, 1 Hole ☒ AG9810 (MLS), 0.65mm, 2 Holes ☒ AG9820 (MLS), 0.70mm, 3 Holes ☒	CG9770▲	EG9770 FG9770▲
Vectra 3.0L V6 CDTi Diesel		06/03 →						
Y 30 DT	2958	6	87.50	Direct Injection, V6	130/177			
Z 30 DT	2958	6	87.50	Direct Injection, V6	135/184			
Vectra 3.2L V6		08/02 →		251				
Z 32 SE	3175	6	88.50	Injection, DOHC, V6	155/211			
Vivaro 1.9L DTI Diesel		08/01 →		252		AC5070 (Fibre), 1.35mm, 2 Notches [30-029474-00] ☒→0.653mm AC5080 (Fibre), 1.45mm, 1 Notch [30-029475-00] ☒0.653→0.786mm AC5090 (Fibre), 1.55mm, 3 Notches [30-029476-00] ☒0.786mm→	CC5060▲ (21-29483-20/0)	EC5060 (22-29474-00/0)
Vivaro Van 1.9L DTI Diesel		08/01 →						
F9Q 760	1870	4	80.00	Direct Injection, SOHC	74/101			







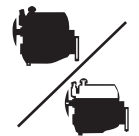



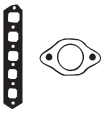

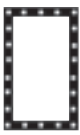





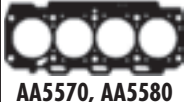
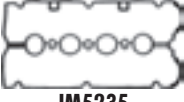
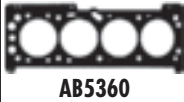



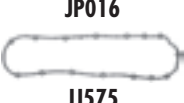





								
HBS054  (22-29013B) M11x1.25x105mm (x10)	JD451  (31-027699-00) JD450  (31-027684-00)  JE120 (31-024767-00)	JP016 (50-027683-00)	JJ615 (31-028793-00) JJ616  [212] (31-028386-00) JJ617  [212] (31-028385-00)	HR791  24-30614-76/0	 NC006  (x2) 35x48x7mm, MVQ (50-319161-00)  NB700  31x50x8mm, FPM (50-306551-50)  NB806  90x104x11mm, FPM (50-306552-00)		AC5070, AC5080, AC5090 BY250 BY270 JD451 JD459 JD5202 JD5203 JD5255 JD5256 JD5347 JE120 JD5204 JM5159 JP016 JH5057 JJ572 JJ573 JJ615	
HBS416  (22-29025B) M11x1.50x163mm (x10)	KG5337  (50-350435-00) (MVQ) JD5868  (31-030346-00)				 NA5108  42x55x7mm, FPM (50-319392-00)  NB806  90x104x11mm, FPM (50-306552-00)			
HBS416  (22-29025B) M11x1.50x163mm (x10)	JD5869  (x3) (31-030358-00) JD5870  (31-030359-00) JD5868  (31-030346-00)		HR397 [57] 34-000410-00		 NA5108  42x55x7mm, FPM (50-319392-00)  NB806  90x104x11mm, FPM (50-306552-00)			
HBS298  (22-29016B) M12x1.50x235mm (x10)	JD5255  (31-029721-00) JD5347   (31-029942-00) JD5256  (31-029722-00)	JM5159 (50-029633-00)	JH5057 (31-029575-00)	HR791  24-30614-76/0	 NA5069  55x68x8mm, FPM (50-319515-00)  NA5209  99x114x11mm, FPM (50-319514-00)			
HBS164  (22-29011B) M11x1.25x105mm (x16)	JD5202  (x2) (50-027980-00) JD5203   (x3) (50-027979-00) JD459  (x2) (31-027698-00)	JD5204 (x2) (50-028690-00)	JJ573  (50-027851-00) JJ572  (50-027852-00)	HR5062  24-30614-73/0	 NC006 (x4) 35x48x7mm, MVQ (50-319161-00)  NB884  38x50x5.5mm, FPM (50-319010-00)  NB806  90x104x11mm, FPM (50-306552-00)			
HBS164  (22-29011B) M11x1.25x105mm (x16)	JD5202  (x2) (50-027980-00) JD5203   (x3) (50-027979-00)	JD5204 (x2) (50-028690-00)		HR5062  24-30614-73/0	 NC006 (x4) 35x48x7mm, MVQ (50-319161-00)  NB884  38x50x5.5mm, FPM (50-319010-00)  NB806  90x104x11mm, FPM (50-306552-00)			
	JD5897  (Steel Elastomer) JD5896   JE5064 (Steel)	HM5292 		HR5094 				
HBS164  (22-29011B) M11x1.25x105mm (x16)					 NC006 (x4) 35x48x7mm, MVQ (50-319161-00)  NB884  38x50x5.5mm, FPM (50-319010-00)  NB806  90x104x11mm, FPM (50-306552-00)			
HBS120  (22-51008B) M12x1.50x118mm (x10)	JD5189	JM5089 	JH5041  KG5012 16x23x1.5mm	HR646  24-30670-60/0	 NF846 25x42x7mm, FPM/ACM (50-319516-00)  NA5036  42x54x6mm, FPM (50-319473-00)  NF850  85x105x8mm, FPM (50-319183-00)	HL5017 [245] 		



KW/PS

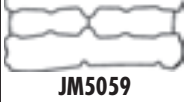

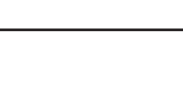
Vivaro 2.0L 16V				08/01 →	253	AD5990 (MLS) (30-029781-00)	CD5991	ED5991
F4R 720	1998	4	82.70	Injection, DOHC	88/120			
Vivaro 2.5L DTI Diesel				04/04 →	254	AE5220 (MLS) (30-029037-00)		EE5220 (22-29037-00/0)
Vivaro Van 2.5L DTI Diesel				04/04 →				
G9U 730	2463	4	89.00	Direct Injection	99/135			
VX 2.3L				01/76 → 10/78	255	AK300 (Fibre)	CK302 ○	EG851
Z3 L	2279	4	97.53		81/110			
VX220 Convertible 2.0L i Turbo				04/03 →	256	AG9570 (MLS) (30-030342-00)	CG9570 (21-30342-00/0)	EG9570
Z 20 LET	1998	4	86.00	Injection, DOHC	140- 147/ 190- 200			
VX220 Convertible 2.2L i				09/00 →	257	AG9580 (MLS) (30-030344-00)	CG9580 (21-30344-00/0)	
Z 22 SE	2198	4	86.00	Injection, DOHC	108/147			
Zafira 1.4L				01/00 →	258	AB5360 (MLS) (30-029200-00)	CB5360 (21-29200-20/0)	EB5360 (22-27665-02/0) → Eng.02M25253 → Eng.20U75999 EB5541 [8] (22-27665-03/0) Eng.02M25254 → Eng.20U76000 →
Z 14 XE	1389	4	77.60	Injection, DOHC	66/89			
Zafira 1.6L				07/05 →	259	AE5930 (MLS) (30-029999-00)	CE5930 (21-29999-20/0)	
Z 16 XEP	1598	4	79.00	Injection, DOHC	74-77/ 101- 105			
Zafira 1.6L 16V				04/99 →	260	AY220 (Fibre)	DY232 (21-27986-25/0)	EY230 (22-27665-01/0)
X 16 XEL	1598	4	79.00	Injection, DOHC	74/100			
Zafira 1.8L 16V				04/99 → 09/00	261	AC5460 (MLS) (30-028674-00)	CC5460 (21-28674-20/0)	
X 18 XE1	1796	4	80.50	Injection, DOHC	85/116			
Z 18 XE	1799	4	80.50	Injection, DOHC	87-92/ 118- 125			
Zafira 1.9L CDTI Diesel				07/05 →	262	AA5570 (MLS), 0.92mm, 1 Hole (30-029094-10) AA5580 (MLS), 1.02mm, 2 Holes (30-029095-10)	CG7390 ▲ (21-30144-00/0)	EE5181 (22-29832-01/0)
Z 19 DT	1910	4	82.00	Direct Injection	74-88/ 100- 120			
Zafira 1.9L CDTI Diesel				07/05 →	263	AD5840 (MLS), 0.82mm, 0 Holes (30-029766-00) AD5850 (MLS), 0.92mm, 1 Hole (30-029767-00) AD5860 (MLS), 1.02mm, 2 Holes (30-029768-00)	CD5840 ▲ (21-29766-20/0)	EE5181 (22-29832-01/0)
Z 19 DTH	1910	4	82.00	Direct Injection	110/150			











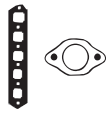

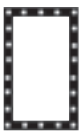

														
HBS310 ® (22-51108B) M12x1.50x117mm (x10)			JH5041 — KG5012 16x23x1.5mm	PA5013 (x16)	NA5036 42x54x6mm, FPM (50-319473-00) NF850 85x105x8mm, FPM (50-319183-00)							AC5460 	JP016 	
HBS373 ® (22-51110B) M12x1.50x131mm (x10)												AE5220 	JJ575 	
HBS054 ® (22-29013B) M11x1.25x105mm (x10)	JD451 11 (31-027699-00) JD5903 13 (31-030367-00) (MLS)	JP016 (50-027683-00)	JJ616 (31-028386-00) JJ617 17 (31-028385-00)	HR791 15 24-30614-76/0	NC006 15 (x2) 35x48x7mm, MVQ (50-319161-00) NB700 15 31x50x8mm, FPM (50-306551-50) NB806 15 90x104x11mm, FPM (50-306552-00)						AE5930 	JJ616 		
HBS416 ® (22-29025B) M11x1.50x163mm (x10)	KG5337 11 (50-350435-00) (MVQ) JD5868 13 (31-030346-00)				NA5108 15 42x55x7mm, FPM (50-319392-00) NB806 15 90x104x11mm, FPM (50-306552-00)						AK300 	JJ617 		
HBS055 ® (22-29012B) M10x1.25x153mm (x10)	JD5147 11 (31-029203-00) JD5149 11 12 (31-029207-00) JD5148 13 (31-029204-00)	JM5059 (50-029202-00)	JJ575 [148] (50-027665-00)	HR791 15 24-30614-76/0	NC006 15 (x2) 35x48x7mm, MVQ (50-319161-00) NB697 15 26x42x8mm, FPM (50-306704-00) NB698 15 80x98x10mm, FPM (50-319273-00)						AY220 			
HBS055 ® (22-29012B) M10x1.25x153mm (x10)	JD5400 11 (31-030002-00) JD5401 13 (31-030004-00)	JM5235 (50-029985-00)		HR5087 15 (24-31951-90/0)	NC006 15 (x2) 35x48x7mm, MVQ (50-319161-00) NA5174 15 31.5x42x7mm, FPM (50-319469-00) NB698 15 80x98x10mm, FPM (50-319273-00)						JD444 			
HBS055 ® (22-29012B) M10x1.25x153mm (x10)	JD5147 11 (31-029203-00) JD444 13 (31-027878-00)	JM5059 (50-029202-00)	JJ575 [148] (50-027665-00)	HR791 15 24-30614-76/0	NC006 15 (x2) 35x48x7mm, MVQ (50-319161-00) NB697 15 26x42x8mm, FPM (50-306704-00) NB698 15 80x98x10mm, FPM (50-319273-00)						JD451 			
HBS055 ® (22-29012B) M10x1.25x153mm (x10)	JD5196 11 (31-029039-00) JD5197 13 (31-029040-00)	JM5092 (50-029087-00)		HR5048 15 (24-31938-60/0)	NC006 15 (x2) 35x48x7mm, MVQ (50-319161-00) NC065 15 30x40x7mm, FPM (50-306142-00) NB698 15 80x98x10mm, FPM (50-319273-00)						JD468 			
HBS227 ® (22-17018B) M12x1.25x218mm (x10)	JD468 13 (31-028377-00) (MLS)	JM5204 (50-029935-00)		HR363 15	NA5053 30x42x7mm, FPM (50-319488-00) NA5070 15 31x41x7mm, FPM (50-319524-00)						JD5147 	JD5148 		
HBS370 ® (22-17026B) M12x1.25x225mm (x10)	JD5376 11 (31-029969-00)	JM7055 (Steel Elastomer)		HR5095 15	NA5053 30x42x7mm, FPM (50-319488-00) NA5070 15 31x41x7mm, FPM (50-319524-00)						JD5149 	JD5196 		
											JD5197 	JD5376 		
											JD5400 	JD5401 		
											JM5059 	JM5092 		
											JM5204 			





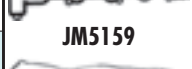













KW/PS



Zafira 2.0L						07/05 →	264	AG9570 (MLS)	CG9570	EG9570
Z 20 LER	1998	4	86.00	Injection, DOHC	147/200		(30-030342-00)	(21-30342-00/0)		
Zafira 2.0L						01/06 →	265			EG9570
Z 20 LEH	1998	4	86.00	Injection, DOHC	177/240					
Zafira 2.0L DI 16V Diesel						10/99 →	266	AB5671 (MLS), 1.30mm, 1 Notch	CB5670▲■	EB5670
Zafira 2.0L DTI 16V Diesel						04/99 →		AB5681 (MLS), 1.40mm, 2 Notches	(21-29011-20/0)	(22-29011-00/0)
X 20 DTL	1995	4	84.00	Direct Injection	60/81					
Y 20 DTH	1995	4	84.00	Direct Injection	74/100					
Zafira 2.0L GSI Turbo						09/01 →	267	AG9570 (MLS)	CG9570	EG9570
Z 20 LET	1998	4	86.00	Injection, DOHC	140- 147/ 190- 200		(30-030342-00)	(21-30342-00/0)		
Zafira 2.2L						07/05 →	268	AG9590 (MLS)	CG9590	
Z 22 YH	2198	4	86.00	Injection	114/155		(30-030345-00)	(21-30345-00/0)		
Zafira 2.2L 16V						09/00 →	269	AG9580 (MLS)	CG9580	
Z 22 SE	2198	4	86.00	Injection, DOHC	108/147		(30-030344-00)	(21-30344-00/0)		

		      				 JD451  JD5255  JD5256  JD5347  JM5159  JP016  JH5057  JJ616  JJ617	
HBS054 Ⓔ (22-29013B) M11x1.25x105mm (x10)	JD5903 Ⓔ (31-030367-00) (MLS)			HR791 Ⓔ 24-30614-76/0	NC006 Ⓔ (x2) 35x48x7mm, MVQ (50-319161-00) NB700 Ⓔ 31x50x8mm, FPM (50-306551-50) NB806 Ⓔ 90x104x11mm, FPM (50-306552-00)		
HBS054 Ⓔ (22-29013B) M11x1.25x105mm (x10)	JD451 Ⓔ (31-027699-00) JD5903 Ⓔ (31-030367-00) (MLS)	JP016 (50-027683-00)	JJ616 (31-028386-00) JJ617 Ⓔ (31-028385-00)	HR791 Ⓔ 24-30614-76/0	NC006 Ⓔ (x2) 35x48x7mm, MVQ (50-319161-00) NB700 Ⓔ 31x50x8mm, FPM (50-306551-50) NB806 Ⓔ 90x104x11mm, FPM (50-306552-00)		
HBS298 Ⓔ (22-29016B) M12x1.50x235mm (x10)	JD5255 Ⓔ (31-029721-00) JD5347 ⒺⒻ (31-029942-00) JD5256 Ⓔ (31-029722-00)	JM5159 (50-029633-00)	JH5057 (31-029575-00)	HR791 Ⓔ 24-30614-76/0	NA5069 Ⓔ 55x68x8mm, FPM (50-319515-00) NA5209 Ⓔ 99x114x11mm, FPM (50-319514-00)		
HBS054 Ⓔ (22-29013B) M11x1.25x105mm (x10)	JD451 Ⓔ (31-027699-00) JD5903 Ⓔ (31-030367-00) (MLS)	JP016 (50-027683-00)	JJ616 (31-028386-00) JJ617 Ⓔ (31-028385-00)	HR791 Ⓔ 24-30614-76/0	NC006 Ⓔ (x2) 35x48x7mm, MVQ (50-319161-00) NB700 Ⓔ 31x50x8mm, FPM (50-306551-50) NB806 Ⓔ 90x104x11mm, FPM (50-306552-00)		
HBS416 Ⓔ (22-29025B) M11x1.50x163mm (x10)	JD5869 Ⓔ (x3) (31-030358-00) JD5870 Ⓔ (31-030359-00) JD5868 Ⓔ (31-030346-00)		HR397 [57] 34-000410-00		NA5108 Ⓔ 42x55x7mm, FPM (50-319392-00) NB806 Ⓔ 90x104x11mm, FPM (50-306552-00)		
HBS416 Ⓔ (22-29025B) M11x1.50x163mm (x10)	KG5337 Ⓔ (50-350435-00) (MVQ) JD5868 Ⓔ (31-030346-00)				NA5108 Ⓔ 42x55x7mm, FPM (50-319392-00) NB806 Ⓔ 90x104x11mm, FPM (50-306552-00)		

		CC			9			CC			9
B 14.4 S	Petrol	1397	4	76.00	13	B 4164 S	Petrol	1587	4	81.00	154
B 14.4 S	Petrol	1397	4	76.00	7	B 4164 S	Petrol	1587	4	81.00	87
B 143 E	Petrol	1397	4	76.00	8	B 4164 S2	Petrol	1587	4	81.00	153
B 16 F	Petrol	1596	4	78.00	19	B 4164 S2	Petrol	1587	4	81.00	86
B 16 F	Petrol	1596	4	78.00	26	B 4164 S3	Petrol	1596	4	79.00	166
B 17 2 K	Petrol	1721	4	81.00	10	B 4164 S3	Petrol	1596	4	79.00	68
B 17 2 K	Petrol	1721	4	81.00	15	B 4164 S3	Petrol	1596	4	79.00	85
B 18 E	Petrol	1721	4	81.00	32	B 4184 S	Petrol	1731	4	83.00	156
B 18 EP	Petrol	1721	4	81.00	21	B 4184 S	Petrol	1731	4	83.00	90
B 18 EP	Petrol	1721	4	81.00	27	B 4184 S11	Petrol	1798	4	83.00	167
B 18 EP	Petrol	1721	4	81.00	32	B 4184 S11	Petrol	1798	4	83.00	89
B 18 F	Petrol	1721	4	81.00	20	B 4184 S2	Petrol	1783	4	83.00	155
B 18 F	Petrol	1721	4	81.00	32	B 4184 S2	Petrol	1783	4	83.00	88
B 18 FP	Petrol	1721	4	81.00	21	B 4184 S3	Petrol	1731	4	83.00	156
B 18 FT	Petrol	1721	4	81.00	22	B 4184 S3	Petrol	1731	4	83.00	90
B 18 FT	Petrol	1721	4	81.00	28	B 4184 S9	Petrol	1783	4	83.00	155
B 18 FT	Petrol	1721	4	81.00	33	B 4184 S9	Petrol	1783	4	83.00	88
B 18 KP	Petrol	1721	4	81.00	21	B 4184 SJ	Petrol	1834	4	81.00	158
B 18 KP	Petrol	1721	4	81.00	27	B 4184 SJ	Petrol	1834	4	81.00	92
B 18 U	Petrol	1794	4	82.70	23	B 4184 SM	Petrol	1834	4	81.00	157
B 18 U	Petrol	1794	4	82.70	29	B 4184 SM	Petrol	1834	4	81.00	91
B 19 A	Petrol	1986	4	88.90	16	B 4194 T	Petrol	1855	4	81.00	161
B 20 F	Petrol	1998	4	82.70	25	B 4194 T	Petrol	1855	4	81.00	95
B 20 F	Petrol	1998	4	82.70	31	B 4194 T2	Petrol	1855	4	81.00	95
B 20 F	Petrol	1998	4	82.70	34	B 4204 S	Petrol	1948	4	83.00	164
B 200 E	Petrol	1986	4	88.90	11	B 4204 S	Petrol	1948	4	83.00	98
B 200 E	Petrol	1986	4	88.90	18	B 4204 S	Petrol	1948	4	83.00	99
B 200 E	Petrol	1986	4	88.90	2	B 4204 S2	Petrol	1948	4	83.00	98
B 200 E	Petrol	1986	4	88.90	35	B 4204 T	Petrol	1948	4	83.00	164
B 200 EA	Petrol	1986	4	88.90	18	B 4204 T	Petrol	1948	4	83.00	99
B 200 ET	Petrol	1986	4	88.90	35	B 4204 T2	Petrol	1948	4	83.00	165
B 200 F	Petrol	1986	4	88.90	11	B 4204 T3	Petrol	1948	4	83.00	100
B 200 F	Petrol	1986	4	88.90	18	B 4204 T3	Petrol	1948	4	83.00	165
B 200 F	Petrol	1986	4	88.90	35	B 4204 T5	Petrol	1948	4	83.00	101
B 200 F	Petrol	1986	4	88.90	56	B 4204 T5	Petrol	1948	4	83.00	165
B 200 FT	Petrol	1986	4	88.90	56	B 5202 S	Petrol	1984	5	81.00	115
B 200 G	Petrol	1986	4	88.90	35	B 5202 S	Petrol	1984	5	81.00	174
B 200 K	Petrol	1986	4	88.90	1	B 5202 S	Petrol	1984	5	81.00	50
B 200 K	Petrol	1986	4	88.90	12	B 5204 F	Petrol	1984	5	81.00	116
B 200 K	Petrol	1986	4	88.90	17	B 5204 F	Petrol	1984	5	81.00	49
B 200 K	Petrol	1986	4	88.90	36	B 5204 FT	Petrol	1984	5	81.00	49
B 204 E	Petrol	1986	4	88.90	37	B 5204 T	Petrol	1984	5	81.00	118
B 204 E	Petrol	1986	4	88.90	55	B 5204 T	Petrol	1984	5	81.00	178
B 204 E	Petrol	1986	4	88.90	62	B 5204 T	Petrol	1984	5	81.00	49
B 204 FT	Petrol	1986	4	88.90	55	B 5204 T2	Petrol	1984	5	81.00	117
B 204 FT	Petrol	1986	4	88.90	61	B 5204 T2	Petrol	1984	5	81.00	176
B 23 A	Petrol	2316	4	96.00	39	B 5204 T2	Petrol	1984	5	81.00	72
B 23 E	Petrol	2316	4	96.00	5	B 5204 T3	Petrol	1984	5	81.00	119
B 230 A	Petrol	2316	4	96.00	38	B 5204 T3	Petrol	1984	5	81.00	136
B 230 A	Petrol	2316	4	96.00	4	B 5204 T3	Petrol	1984	5	81.00	179
B 230 E	Petrol	2316	4	96.00	3	B 5204 T3	Petrol	1984	5	81.00	180
B 230 E	Petrol	2316	4	96.00	39	B 5204 T3	Petrol	1984	5	81.00	74
B 230 ET	Petrol	2316	4	96.00	39	B 5204 T4	Petrol	1984	5	81.00	114
B 230 ET	Petrol	2316	4	96.00	46	B 5204 T4	Petrol	1984	5	81.00	136
B 230 F	Petrol	2316	4	96.00	3	B 5204 T4	Petrol	1984	5	81.00	173
B 230 F	Petrol	2316	4	96.00	39	B 5204 T4	Petrol	1984	5	81.00	73
B 230 FB	Petrol	2316	4	96.00	39	B 5204 T4	Petrol	1984	5	81.00	75
B 230 FB	Petrol	2316	4	96.00	58	B 5204 T5	Petrol	1984	5	81.00	104
B 230 FD	Petrol	2316	4	96.00	58	B 5204 T5	Petrol	1984	5	81.00	137
B 230 FK	Petrol	2316	4	96.00	58	B 5204 T5	Petrol	1984	5	81.00	177
B 230 FT	Petrol	2316	4	96.00	42	B 5234 FT	Petrol	2319	5	81.00	51
B 230 FT	Petrol	2316	4	96.00	45	B 5234 FT+	Petrol	2319	5	81.00	123
B 230 FT	Petrol	2316	4	96.00	58	B 5234 FT+	Petrol	2319	5	81.00	182
B 230 FT+	Petrol	2316	4	96.00	58	B 5234 T3	Petrol	2319	5	81.00	105
B 230 G	Petrol	2316	4	96.00	58	B 5234 T3	Petrol	2319	5	81.00	120
B 230 GT	Petrol	2316	4	96.00	42	B 5234 T3	Petrol	2319	5	81.00	121
B 230 K	Petrol	2316	4	96.00	41	B 5234 T3	Petrol	2319	5	81.00	183
B 234 F	Petrol	2316	4	96.00	40	B 5234 T3	Petrol	2319	5	81.00	184
B 234 F	Petrol	2316	4	96.00	57	B 5234 T3	Petrol	2319	5	81.00	185
B 234 G	Petrol	2316	4	96.00	57	B 5234 T3	Petrol	2319	5	81.00	77











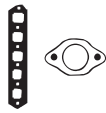

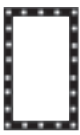

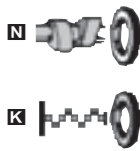



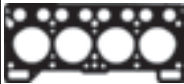







		CC			9			CC			9
B 5234 T4	Petrol	2319	5	81.00	122	B 5254 T2	Petrol	2521	5	83.00	208
B 5234 T4	Petrol	2319	5	81.00	183	B 5254 T3	Petrol	2521	5	83.00	103
B 5234 T4	Petrol	2319	5	81.00	51	B 5254 T3	Petrol	2521	5	83.00	171
B 5234 T7	Petrol	2319	5	81.00	138	B 5254 T3	Petrol	2521	5	83.00	70
B 5234 T7	Petrol	2319	5	81.00	181	B 5254 T3	Petrol	2521	5	83.00	82
B 5234 T7	Petrol	2319	5	81.00	185	B 5254 T4	Petrol	2521	5	83.00	113
B 5234 T8	Petrol	2319	5	81.00	181	B 5254 T4	Petrol	2521	5	83.00	199
B 5234 T9	Petrol	2319	5	81.00	76	B 5254 T4	Petrol	2521	5	83.00	202
B 5244 S	Petrol	2435	5	83.00	107	B 6254 S	Petrol	2473	6	81.00	64
B 5244 S	Petrol	2435	5	83.00	125	B 6284 T	Petrol	2783	6	83.00	147
B 5244 S	Petrol	2435	5	83.00	128	B 6294 S	Petrol	2922	6	83.00	148
B 5244 S	Petrol	2435	5	83.00	139	B 6294 S2	Petrol	2922	6	83.00	150
B 5244 S	Petrol	2435	5	83.00	170	B 6294 T	Petrol	2922	6	83.00	151
B 5244 S	Petrol	2435	5	83.00	188	B 6294 T	Petrol	2922	6	83.00	209
B 5244 S	Petrol	2435	5	83.00	83	B 6304 F	Petrol	2922	6	83.00	65
B 5244 S2	Petrol	2435	5	83.00	106	B 6304 F	Petrol	2922	6	83.00	66
B 5244 S2	Petrol	2435	5	83.00	124	B 6304 G	Petrol	2922	6	83.00	152
B 5244 S2	Petrol	2435	5	83.00	127	B 6304 G	Petrol	2922	6	83.00	203
B 5244 S2	Petrol	2435	5	83.00	140	B 6304 S	Petrol	2922	6	83.00	66
B 5244 S2	Petrol	2435	5	83.00	186	B 6304 S	Petrol	2922	6	83.00	67
B 5244 S2	Petrol	2435	5	83.00	187	B 6304 S2	Petrol	2922	6	83.00	152
B 5244 S4	Petrol	2435	5	83.00	78	B 6304 S2	Petrol	2922	6	83.00	203
B 5244 S5	Petrol	2435	5	83.00	102	B 6304 S3	Petrol	2922	6	83.00	149
B 5244 S5	Petrol	2435	5	83.00	169	D 16	Diesel	1595	4	78.00	14
B 5244 S5	Petrol	2435	5	83.00	78	D 16	Diesel	1595	4	78.00	9
B 5244 SG	Petrol	2435	5	83.00	124	D 19 T	Diesel	1870	4	80.00	24
B 5244 SG	Petrol	2435	5	83.00	127	D 19 T	Diesel	1870	4	80.00	30
B 5244 SG	Bi-Fuel	2435	5	83.00	134	D 24	Diesel	2383	6	76.50	43
B 5244 SG	Bi-Fuel	2435	5	83.00	187	D 24	Diesel	2383	6	76.50	47
B 5244 SG2	Petrol	2435	5	83.00	186	D 24	Diesel	2383	6	76.50	59
B 5244 SG2	Bi-Fuel	2435	5	83.00	109	D 24	Diesel	2383	6	76.50	6
B 5244 SG2	Bi-Fuel	2435	5	83.00	141	D 24 T	Diesel	2383	6	76.50	44
B 5244 T	Petrol	2435	5	83.00	126	D 24 T	Diesel	2383	6	76.50	48
B 5244 T	Petrol	2435	5	83.00	194	D 24 T	Diesel	2383	6	76.50	60
B 5244 T	Petrol	2435	5	83.00	201	D 24 TIC	Diesel	2383	6	76.50	44
B 5244 T	Petrol	2435	5	83.00	81	D 24 TIC	Diesel	2383	6	76.50	48
B 5244 T	Petrol	2435	5	83.00	84	D 24 TIC	Diesel	2383	6	76.50	60
B 5244 T2	Petrol	2435	5	83.00	190	D 24 TIC	Diesel	2383	6	76.50	63
B 5244 T3	Petrol	2435	5	83.00	111	D 4192 T	Diesel	1870	4	80.00	162
B 5244 T3	Petrol	2435	5	83.00	143	D 4192 T	Diesel	1870	4	80.00	96
B 5244 T3	Petrol	2435	5	83.00	144	D 4192 T2	Diesel	1870	4	80.00	159
B 5244 T3	Petrol	2435	5	83.00	192	D 4192 T2	Diesel	1870	4	80.00	93
B 5244 T3	Petrol	2435	5	83.00	205	D 4192 T3	Diesel	1870	4	80.00	160
B 5244 T5	Petrol	2401	5	81.00	108	D 4192 T3	Diesel	1870	4	80.00	94
B 5244 T5	Petrol	2401	5	81.00	112	D 4192 T4	Diesel	1870	4	80.00	160
B 5244 T5	Petrol	2401	5	81.00	193	D 4192 T4	Diesel	1870	4	80.00	94
B 5244 T7	Petrol	2435	5	83.00	79	D 4204 T	Diesel	1998	4	85.00	135
B 5252	Petrol	2435	5	83.00	52	D 4204 T	Diesel	1998	4	85.00	163
B 5252 S	Petrol	2435	5	83.00	132	D 4204 T	Diesel	1998	4	85.00	168
B 5252 S	Petrol	2435	5	83.00	197	D 4204 T	Diesel	1998	4	85.00	172
B 5252 S	Petrol	2435	5	83.00	52	D 4204 T	Diesel	1998	4	85.00	69
B 5254 F	Petrol	2435	5	83.00	196	D 4204 T	Diesel	1998	4	85.00	71
B 5254 S	Petrol	2435	5	83.00	125	D 4204 T	Diesel	1998	4	85.00	97
B 5254 S	Petrol	2435	5	83.00	189	D 5244 T	Diesel	2401	5	81.00	110
B 5254 S	Petrol	2435	5	83.00	196	D 5244 T	Diesel	2401	5	81.00	142
B 5254 S	Petrol	2435	5	83.00	53	D 5244 T	Diesel	2401	5	81.00	191
B 5254 S	Petrol	2435	5	83.00	80	D 5244 T	Diesel	2401	5	81.00	204
B 5254 S	Petrol	2435	5	83.00	83	D 5244 T	Diesel	2401	5	81.00	207
B 5254 T	Petrol	2435	5	83.00	126	D 5244 T2	Diesel	2401	5	81.00	110
B 5254 T	Petrol	2435	5	83.00	129	D 5244 T2	Diesel	2401	5	81.00	142
B 5254 T	Petrol	2435	5	83.00	194	D 5244 T2	Diesel	2401	5	81.00	191
B 5254 T	Petrol	2435	5	83.00	201	D 5252 T	Diesel	2401	5	81.00	130
B 5254 T	Petrol	2435	5	83.00	53	D 5252 T	Diesel	2401	5	81.00	146
B 5254 T	Petrol	2435	5	83.00	81	D 5252 T	Diesel	2401	5	81.00	195
B 5254 T	Petrol	2435	5	83.00	84	D 5252 T	Diesel	2401	5	81.00	54
B 5254 T2	Petrol	2521	5	83.00	113	GB 5252 S	Bi-Fuel	2435	5	83.00	133
B 5254 T2	Petrol	2521	5	83.00	145	GB 5252 S	Bi-Fuel	2435	5	83.00	198
B 5254 T2	Petrol	2521	5	83.00	199						
B 5254 T2	Petrol	2521	5	83.00	200						
B 5254 T2	Petrol	2521	5	83.00	206						



KW/PS



240 2.0L				08/84 → 07/85		1	BD070 (Fibre) (30-026435-00)	DD072	EH445 (22-24158-04/0)
B 200 K	1986	4	88.90	Carburettor, SOHC	70-77/ 95-105				
240 2.0L				08/83 → 07/93		2	BD070 (Fibre) (30-026435-00)	DD073 (21-26435-22/0)	EH445 (22-24158-04/0)
B 200 E	1986	4	88.90	Injection, SOHC	82-87/ 112- 118				
240 2.3L				08/83 → 07/92		3	BK640 (Fibre) (30-024669-10)	DK643 (21-24669-24/0)	EH445 (22-24158-04/0)
240 2.3L i				08/86 → 07/93					
B 230 F	2316	4	96.00	Injection, SOHC	81-100/ 110- 136				
B 230 E	2316	4	96.00	Injection, SOHC	96-98/ 131- 133				
240 2.3L				08/84 → 07/86		4	BK640 (Fibre) (30-024669-10)	DK642 (21-24669-26/0)	EH445 (22-24158-04/0)
B 230 A	2316	4	96.00	Carburettor	81-86/ 110- 117				
240 2.3L				08/84 → 12/89		5	BK640 (Fibre) (30-024669-10)	DK640 (21-24669-25/0)	EH445 (22-24158-04/0)
B 23 E	2316	4	96.00	K-Jetronic, SOHC	91-103/ 124- 140				
240 2.4L Diesel				08/78 → 08/93		6	BZ930 (MLS), 1.57mm, 2 Holes 30-028809-00 BW680 (Fibre), 1.53mm, 1 Notch Eng.41876 → BW690 (Fibre), 1.57mm, 2 Notches 30-027337-10 Eng.41876 → BW700 (Fibre), 1.61mm, 3 Notches Eng.41876 →	DM631▲ (21-24536-22/0) Eng.41876 →	EX980 22-27422-00/0
D 24	2383	6	76.50		58-60/ 79-82				
340 1.4L				08/83 → 12/88		7	BH690 (Fibre), 1.20mm (30-024733-10) BM800 (Fibre), 1.75mm [34]	DH696■	EZ142 [36]
B 14.4 S	1397	4	76.00	Carburettor, OHV	50-53/ 68-72				
340 1.4L				08/82 → 08/85		8	BH690 (Fibre), 1.20mm (30-024733-10) BM800 (Fibre), 1.75mm [34]	DH697■	EZ142 [36]
B 143 E	1397	4	76.00		46-53/ 63-72				











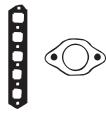

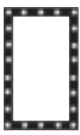

















								
HBS174 ⊕ (22-47001B) M12x1.75x133mm (x10)	JC440 ■ (31-025331-10) JB917 ■ (x4) (31-026434-00) ⊙ JE248 (31-024200-10)	JN635 (31-026392-00)	JJ065 (31-024158-10)	HR641 ■ (50-305909-00)	■ NA5016 35x47x7mm, FPM/ACM (50-305690-50) ■ NA581 ■ 52x68x10mm, MVQ (50-305276-00) ■ NA869 ■ 92x110x10mm, FPM (50-319023-10)	NA5016 [42]		 BD070  JN635  BH690  HC354  BK640  JJ065  BM800  BW680, BW690, BW700  JJ551  BZ930  JB851  JB917  JB926  JB997  JC146  JC152  JC440  JE248  HL469  JN248  JN279
HBS174 ⊕ (22-47001B) M12x1.75x133mm (x10)	JC440 ■ (31-025331-10) JB917 ■ (x4) (31-026434-00) ⊙ JE248 (31-024200-10)	JN635 (31-026392-00)	JJ065 (31-024158-10)	HR641 ■ (50-305909-00)	■ NA5016 35x47x7mm, FPM/ACM (50-305690-50) ■ NA581 ■ 52x68x10mm, MVQ (50-305276-00) ■ NA869 ■ 92x110x10mm, FPM (50-319023-10)	NA5016 [42]		
HBS174 ⊕ (22-47001B) M12x1.75x133mm (x10)	JC440 ■ (31-025331-10) JB917 ■ (x4) (31-026434-00) ⊙ JE248 (31-024200-10)	JN635 (31-026392-00)	JJ065 (31-024158-10)	HR641 ■ (50-305909-00)	■ NA5016 35x47x7mm, FPM/ACM (50-305690-50) ■ NA581 ■ 52x68x10mm, MVQ (50-305276-00) ■ NA869 ■ 92x110x10mm, FPM (50-319023-10)	NA5016 [42]		
HBS174 ⊕ (22-47001B) M12x1.75x133mm (x10)	JC440 ■ (31-025331-10) JB917 ■ (x4) (31-026434-00) ⊙ JE248 (31-024200-10)	JN635 (31-026392-00)	JJ065 (31-024158-10)	HR641 ■ (50-305909-00)	■ NA5016 35x47x7mm, FPM/ACM (50-305690-50) ■ NA581 ■ 52x68x10mm, MVQ (50-305276-00) ■ NA869 ■ 92x110x10mm, FPM (50-319023-10)	NA5016 [42]		
HBS174 ⊕ (22-47001B) M12x1.75x133mm (x10)	JB926 ■ (31-026434-00) JB917 ■ (x4) (31-026434-00) ⊙ JE248 (31-024200-10)	JN279 (31-026432-00)	JJ065 (31-024158-10)	HR641 ■ (50-305909-00)	■ NA5016 35x47x7mm, FPM/ACM (50-305690-50) ■ NA581 ■ 52x68x10mm, MVQ (50-305276-00) ■ NA869 ■ 92x110x10mm, FPM (50-319023-10)	NA5016 [42]		
HBS022 ⊕ (22-39005B) M12x1.75x115mm (x14)	JC146 ■ 31-024044-20 JC152 ■ (x6) 31-026555-00	HL469 ■ 24-24042-00/0 →02/81 →Eng.41875	JJ551 (31-024893-10)	HR805 ■	■ NA5001 32x47x10mm, FPM (50-303185-50) ■ NB716 ■ 35x48x10mm, FPM (50-306067-50) ■ NA5133 ■ 85x105x11mm, FPM (24-30727-87/0)			
HBS104 ⊕ (22-51005B) M10x1.50x100mm (x10)	JB851 (x4) (31-022715-10)	JN248 (50-026305-00)	HC354 ■		■ NF722 ■ 35x50x10mm, MVQ ■ NF634 ■ 80x100x13mm, MVQ (50-319343-00)			
HBS104 ⊕ (22-51005B) M10x1.50x100mm (x10)	JB997	JN248 (50-026305-00)	HC354 ■		■ NF722 ■ 35x50x10mm, MVQ ■ NF634 ■ 80x100x13mm, MVQ (50-319343-00)			



KW/PS



340 1.6L D Diesel		08/84 → 07/91			9			
D 16	1595	4	78.00		40/54	BL960 (Fibre), 1.65mm, 2 Holes [33] (30-026968-10) →Eng.34499 →0.885mm BL970 (Fibre), 1.75mm, 1 Hole (30-026969-10) →Eng.34499 →0.885→0.985mm BL980 (Fibre), 1.85mm, 3 Holes →Eng.34499 →0.985mm→ BS010 (Fibre), 1.65mm, 2 Holes (30-025301-20) Eng.34500→ →0.885mm BS020 (Fibre), 1.75mm, 1 Hole (30-025302-20) Eng.34500→ →0.885→0.985mm BS030 (Fibre), 1.85mm, 3 Holes (30-025303-20) Eng.34500→ →0.985mm→	DL961▲ (21-26632-21/0)	EL960 [8] (22-27574-00/0)
340 1.7L		08/85 → 07/91			10			
B 17 2 K	1721	4	81.00		60/81	BL910 (Fibre), 1.20mm (30-026613-00)	DL910 DL911 (21-26613-23/0)	EL960 [8] (22-27574-00/0)
340 2.0L		08/84 → 07/89			11			
B 200 F	1986	4	88.90	Injection, SOHC	82/111	BD070 (Fibre) (30-026435-00)	DD073 (21-26435-22/0)	EH445 (22-24158-04/0)
B 200 E	1986	4	88.90	Injection, SOHC	82-87/ 112- 118			
340 2.0L		08/84 → 07/87			12			
B 200 K	1986	4	88.90	Carburettor, SOHC	70-77/ 95-105	BD070 (Fibre) (30-026435-00)	DD072	EH445 (22-24158-04/0)
360 1.4L		08/83 → 12/88			13			
B 14.4 S	1397	4	76.00	Carburettor, OHV	50-53/ 68-72	BH690 (Fibre), 1.20mm (30-024733-10) BM800 (Fibre), 1.75mm [34]	DH696■	EZ142 [36]











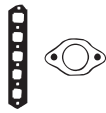

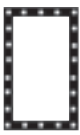

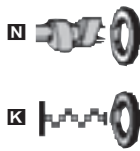













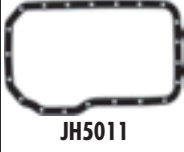





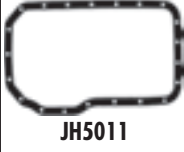





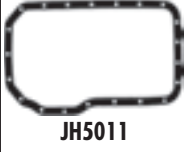





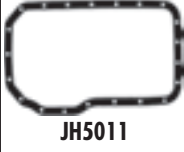





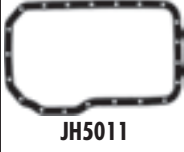







								
HBS244 ⊕ (22-51103B) M12x1.50x111mm (x10)	JD409 (31-026628-10)	JN732 (50-026632-00)	JJ557 PA349 (33-102290-10) 22x16x2mm	HR569 ⊖ 24-30667-00/0	NF846 ⊖ 25x42x7mm, FPM/ACM (50-319516-00) NF843 ⊖ 50x68x10mm, FPM/ACM (50-305667-70) NF850 ⊖ 85x105x8mm, FPM (50-319183-00)	NF791 [38] KA625 [13]		 BD070  BH690  BL910  BL960, BL970, BL980  BM800  BS010, BS020, BS030  JB851  JB917  JC440  JD409  JE248  JN248  JN635  JN732  HC354
HBS244 ⊕ (22-51103B) M12x1.50x111mm (x10)	JD409 (31-026628-10)	JN732 (50-026632-00)	JJ557 PA349 (33-102290-10) 22x16x2mm	HR569 ⊖ 24-30667-00/0	NA5016 35x47x7mm, FPM/ACM (50-305690-50) NF843 ⊖ 50x68x10mm, FPM/ACM (50-305667-70) NF850 ⊖ 85x105x8mm, FPM (50-319183-00)			 JC440  JD409  JE248
HBS174 ⊕ (22-47001B) M12x1.75x133mm (x10)	JC440 ⊖ (31-025331-10) JB917 ⊖ (x4) (31-026434-00) JE248 (31-024200-10)	JN635 (31-026392-00)	JJ065 (31-024158-10)	HR641 ⊖ (50-305909-00)	NA5016 35x47x7mm, FPM/ACM (50-305690-50) NA581 ⊖ 52x68x10mm, MVQ (50-305276-00) NA869 ⊖ 92x110x10mm, FPM (50-319023-10)	NA5016 [42]		 JN248  JN635  JN732
HBS174 ⊕ (22-47001B) M12x1.75x133mm (x10)	JC440 ⊖ (31-025331-10) JB917 ⊖ (x4) (31-026434-00) JE248 (31-024200-10)	JN635 (31-026392-00)	JJ065 (31-024158-10)	HR641 ⊖ (50-305909-00)	NA5016 35x47x7mm, FPM/ACM (50-305690-50) NA581 ⊖ 52x68x10mm, MVQ (50-305276-00) NA869 ⊖ 92x110x10mm, FPM (50-319023-10)	NA5016 [42]		 JN635  JN732
HBS104 ⊕ (22-51005B) M10x1.50x100mm (x10)	JB851 (31-022715-10)	JN248 (50-026305-00)	HC354 ⊖		NF722 ⊖ 35x50x10mm, MVQ NF634 ⊖ 80x100x13mm, MVQ (50-319343-00)			 HC354



KW/PS

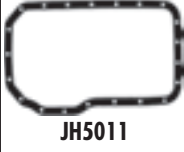

360 1.6L D Diesel				08/84 → 07/91	14			
D 16	1595	4	78.00		40/54	BL960 (Fibre), 1.65mm, 2 Holes [33] (30-026968-10) →Eng.34499 ☞→0.885mm BL970 (Fibre), 1.75mm, 1 Hole (30-026969-10) →Eng.34499 ☞0.885→0.985mm BL980 (Fibre), 1.85mm, 3 Holes →Eng.34499 ☞0.985mm→ BSO10 (Fibre), 1.65mm, 2 Holes (30-025301-20) Eng.34500→ ☞→0.885mm BSO20 (Fibre), 1.75mm, 1 Hole (30-025302-20) Eng.34500→ ☞0.885→0.985mm BSO30 (Fibre), 1.85mm, 3 Holes (30-025303-20) Eng.34500→ ☞0.985mm→	DL961▲ (21-26632-21/0)	EL960 [8] (22-27574-00/0)
360 1.7L				08/85 → 07/91	15			
B 17 2 K	1721	4	81.00		60/81	BL910 (Fibre), 1.20mm (30-026613-00)	DL910 DL911 (21-26613-23/0)	EL960 [8] (22-27574-00/0)
360 2.0L				08/82 → 07/84	16			
B 19 A	1986	4	88.90		65-71/ 88-97	BD070 (Fibre) (30-026435-00)	DD070 (21-26435-21/0)	EH445 (22-24158-04/0)
360 2.0L				08/84 → 07/90	17			
B 200 K	1986	4	88.90	Carburettor, SOHC	70-77/ 95-105	BD070 (Fibre) (30-026435-00)	DD072	EH445 (22-24158-04/0)
360 2.0L				08/84 → 07/89	18			
B 200 EA	1986	4	88.90	Injection, SOHC	81-82/ 110- 112	BD070 (Fibre) (30-026435-00)	DD073 (21-26435-22/0)	EH445 (22-24158-04/0)
B 200 F	1986	4	88.90	Injection, SOHC	82-87/ 112- 118			
B 200 E	1986	4	88.90	Injection, SOHC				
440 1.6L				09/88 → 12/96	19			
B 16 F	1596	4	78.00	Injection, SOHC	61/82	AE5040 (Fibre) (30-026530-10)		











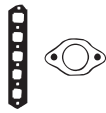

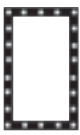

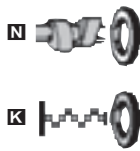

								
HBS244 Ⓢ (22-51103B) M12x1.50x111mm (x10)	JD409 (31-026628-10)	JN732 (50-026632-00)	JJ557 ● PA349 (33-102290-10) 22x16x2mm	HR569 Ⓢ 24-30667-00/0	NF846 Ⓢ 25x42x7mm, FPM/ACM (50-319516-00) NF843 Ⓢ 50x68x10mm, FPM/ACM (50-305667-70) NF850 Ⓢ 85x105x8mm, FPM (50-319183-00)	NF791 [38] KA625 [13]		 AE5040  BD070  BL910  BL960, BL970, BL980  BS010, BS020, BS030  JB917  JC440  JD409  JE248  JN279  JN635  JN732  JH5011  JJ065  JJ557
HBS244 Ⓢ (22-51103B) M12x1.50x111mm (x10)	JD409 (31-026628-10)	JN732 (50-026632-00)	JJ557 ● PA349 (33-102290-10) 22x16x2mm	HR569 Ⓢ 24-30667-00/0	NA5016 35x47x7mm, FPM/ACM (50-305690-50) NF843 Ⓢ 50x68x10mm, FPM/ACM (50-305667-70) NF850 Ⓢ 85x105x8mm, FPM (50-319183-00)			 JE248  JN279  JN635  JN732  JH5011  JJ065  JJ557
HBS174 Ⓢ (22-47001B) M12x1.75x133mm (x10)	JC440 Ⓢ (31-025331-10) JB917 Ⓢ (x4) (31-026434-00) ● JE248 (31-024200-10)	JN279 (31-026432-00)	JJ065 (31-024158-10)	HR641 Ⓢ (50-305909-00)	NA5016 35x47x7mm, FPM/ACM (50-305690-50) NA581 Ⓢ 52x68x10mm, MVQ (50-305276-00) NA869 Ⓢ 92x110x10mm, FPM (50-319023-10)	NA5016 [42]		 JE248  JN279  JN635  JN732  JH5011  JJ065  JJ557
HBS174 Ⓢ (22-47001B) M12x1.75x133mm (x10)	JC440 Ⓢ (31-025331-10) JB917 Ⓢ (x4) (31-026434-00) ● JE248 (31-024200-10)	JN635 (31-026392-00)	JJ065 (31-024158-10)	HR641 Ⓢ (50-305909-00)	NA5016 35x47x7mm, FPM/ACM (50-305690-50) NA581 Ⓢ 52x68x10mm, MVQ (50-305276-00) NA869 Ⓢ 92x110x10mm, FPM (50-319023-10)	NA5016 [42]		 JE248  JN279  JN635  JN732  JH5011  JJ065  JJ557
HBS174 Ⓢ (22-47001B) M12x1.75x133mm (x10)	JC440 Ⓢ (31-025331-10) JB917 Ⓢ (x4) (31-026434-00) ● JE248 (31-024200-10)	JN635 (31-026392-00)	JJ065 (31-024158-10)	HR641 Ⓢ (50-305909-00)	NA5016 35x47x7mm, FPM/ACM (50-305690-50) NA581 Ⓢ 52x68x10mm, MVQ (50-305276-00) NA869 Ⓢ 92x110x10mm, FPM (50-319023-10)	NA5016 [42]		 JE248  JN279  JN635  JN732  JH5011  JJ065  JJ557
HBS244 Ⓢ (22-51103B) M12x1.50x111mm (x10)	JD409 (31-026628-10)	JN732 (50-026632-00)	JH5011 (31-028402-00)	HR569 Ⓢ 24-30667-00/0	NF846 Ⓢ 25x42x7mm, FPM/ACM (50-319516-00) NF847 Ⓢ 22x45x7mm, FPM/ACM NF843 Ⓢ 50x68x10mm, FPM/ACM (50-305667-70) NF850 Ⓢ 85x105x8mm, FPM (50-319183-00)			 AE5040  BD070  BL910  BL960, BL970, BL980  BS010, BS020, BS030  JB917  JC440  JD409  JE248  JN279  JN635  JN732  JH5011  JJ065  JJ557



KW/PS



440 1.7L				08/88 → 07/89		20	BL910 (Fibre), 1.20mm (30-026613-00)	DL910	
B 18 F	1721	4	81.00	Injection, SOHC	70-75/ 95-102				
440 1.7L				09/88 → 12/96		21	BL910 (Fibre), 1.20mm (30-026613-00)	DL910	EL960 [8] (22-27574-00/0) 10/90 →
B 18 KP	1721	4	81.00	Injection	64-66/ 87-90				
B 18 EP	1721	4	81.00	Injection, SOHC	75/102				
B 18 FP	1721	4	81.00		75/102				
440 1.7L Turbo				08/88 → 12/96		22	BX080 (Fibre) (30-027127-00)	DL916 (21-27127-20/0)	EL960 [8] (22-27574-00/0)
B 18 FT	1721	4	81.00	SOHC	88/120				
440 1.8L				08/91 → 12/96		23	BX600 (Fibre) (30-027850-00)	DX600 (21-27850-20/0)	EL960 [8] (22-27574-00/0)
B 18 U	1794	4	82.70	Injection, SOHC	66/89				
440 1.9L Turbo-D Diesel				07/94 → 12/96		24	AY710 (Steel Elastomer), 1.36mm, 2 Holes (30-029016-00) → 0.073mm AY720 (Steel Elastomer), 1.44mm, 1 Hole (30-029017-00) → 0.073 → 0.206mm AY730 (Steel Elastomer), 1.52mm, 3 Holes (30-029018-00) → 0.206mm →	DY040▲ (21-26632-23/0)	EL960 [8] (22-27574-00/0)
D 19 T	1870	4	80.00		60-85/ 82-116				
440 2.0L				08/92 → 07/96		25	BX600 (Fibre) (30-027850-00)	DX600 (21-27850-20/0)	
B 20 F	1998	4	82.70	SOHC	80-85/ 108- 115				
460 1.6L				07/92 → 07/96		26	AE5040 (Fibre) (30-026530-10)		
B 16 F	1596	4	78.00	Injection, SOHC	61/82				
460 1.7L				09/88 → 07/96		27	BL910 (Fibre), 1.20mm (30-026613-00)	DL910 DL911 (21-26613-23/0)	EL960 [8] (22-27574-00/0)
B 18 KP	1721	4	81.00	Injection	64-66/ 87-90				
B 18 EP	1721	4	81.00		75/102				







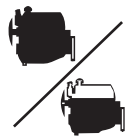



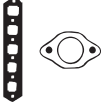

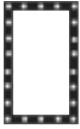

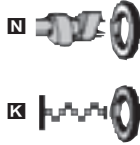







								
HBS244 ® (22-51103B) M12x1.50x111mm (x10)	JD409 (31-026628-10)	JN732 (50-026632-00)	JJ557 ● PA349 (33-102290-10) 22x16x2mm	HR569 ■ 24-30667-00/0	NF846 ■ 25x42x7mm, FPM/ACM (50-319516-00) NF847 ■ 22x45x7mm, FPM/ACM NF843 ■ 50x68x10mm, FPM/ACM (50-305667-70) NF850 ■ 85x105x8mm, FPM (50-319183-00)			 AE5040  AY710, AY720, AY730  BL910  BX080  BX600  JD409  JD419  JD463  JN732  JH5011  JJ557
HBS244 ® (22-51103B) M12x1.50x111mm (x10)	JD409 (31-026628-10)	JN732 (50-026632-00)	JJ557	HR569 ■ 24-30667-00/0	NF846 ■ 25x42x7mm, FPM/ACM (50-319516-00) NF847 ■ 22x45x7mm, FPM/ACM NF843 ■ 50x68x10mm, FPM/ACM (50-305667-70) NF850 ■ 85x105x8mm, FPM (50-319183-00)			
HBS244 ® (22-51103B) M12x1.50x111mm (x10)		JN732 (50-026632-00)	JH5011 (31-028402-00)	HR569 ■ 24-30667-00/0	NF846 ■ 25x42x7mm, FPM/ACM (50-319516-00) NF847 ■ 22x45x7mm, FPM/ACM NF843 ■ 50x68x10mm, FPM/ACM (50-305667-70) NF850 ■ 85x105x8mm, FPM (50-319183-00)			
HBS244 ® (22-51103B) M12x1.50x111mm (x10)	JD419 (31-027573-00)	JN732 (50-026632-00)	JJ557 ● PA349 (33-102290-10) 22x16x2mm	HR569 ■ 24-30667-00/0	NF843 ■ 50x68x10mm, FPM/ACM (50-305667-70) NF850 ■ 85x105x8mm, FPM (50-319183-00)			
HBS120 ® (22-51008B) M12x1.50x118mm (x10)	JD463	JN732 (50-026632-00)	JH5011 (31-028402-00) ● KG5012 16x23x1.5mm	HR569 ■ 24-30667-00/0	NF846 ■ 25x42x7mm, FPM/ACM (50-319516-00) NF843 ■ 50x68x10mm, FPM/ACM (50-305667-70) NF850 ■ 85x105x8mm, FPM (50-319183-00)	HL5013 [245]■ NF791 [38] KA625 [13] NF849 [15]		
HBS244 ® (22-51103B) M12x1.50x111mm (x10)	JD419 (31-027573-00)	JN732 (50-026632-00)	JH5011 (31-028402-00)	HR805 ■	NF846 ■ 25x42x7mm, FPM/ACM (50-319516-00) NF847 ■ 22x45x7mm, FPM/ACM NF843 ■ 50x68x10mm, FPM/ACM (50-305667-70) NF850 ■ 85x105x8mm, FPM (50-319183-00)			
HBS244 ® (22-51103B) M12x1.50x111mm (x10)	JD409 (31-026628-10)	JN732 (50-026632-00)	JH5011 (31-028402-00)	HR569 ■ 24-30667-00/0	NF846 ■ 25x42x7mm, FPM/ACM (50-319516-00) NF847 ■ 22x45x7mm, FPM/ACM NF843 ■ 50x68x10mm, FPM/ACM (50-305667-70) NF850 ■ 85x105x8mm, FPM (50-319183-00)			
HBS244 ® (22-51103B) M12x1.50x111mm (x10)	JD409 (31-026628-10)	JN732 (50-026632-00) 10/90 →	JJ557 ● PA349 (33-102290-10) 22x16x2mm	HR569 ■ 24-30667-00/0	NF846 ■ 25x42x7mm, FPM/ACM (50-319516-00) NF847 ■ 22x45x7mm, FPM/ACM NF843 ■ 50x68x10mm, FPM/ACM (50-305667-70) NF850 ■ 85x105x8mm, FPM (50-319183-00)			



KW/PS



460 1.7L Turbo					08/89 → 07/96	28	BX080 (Fibre) (30-027127-00)	DL916 (21-27127-20/0)	EL960 [8] (22-27574-00/0)
B 18 FT	1721	4	81.00	SOHC		88/120			
460 1.8L					08/91 → 07/96	29	BX600 (Fibre) (30-027850-00)	DX600 (21-27850-20/0)	EL960 [8] (22-27574-00/0)
B 18 U	1794	4	82.70	Injection, SOHC		66/89			
460 1.9L Turbo-D Diesel					07/94 → 07/96	30	AY710 (Steel Elastomer), 1.36mm, 2 Holes (30-029016-00) →+0.073mm AY720 (Steel Elastomer), 1.44mm, 1 Hole (30-029017-00) →-0.073 → +0.206mm AY730 (Steel Elastomer), 1.52mm, 3 Holes (30-029018-00) →-0.206mm →	DY040▲ (21-26632-23/0)	EL960 [8] (22-27574-00/0)
D 19 T	1870	4	80.00			60-85/ 82-116			
460 2.0L					08/92 → 07/96	31	BX600 (Fibre) (30-027850-00)	DX600 (21-27850-20/0)	
B 20 F	1998	4	82.70	SOHC		80-85/ 108- 115			
480 Coupe 1.7L					04/86 → 07/96	32	BL910 (Fibre), 1.20mm (30-026613-00)	DL910	
B 18 F	1721	4	81.00	Injection, SOHC		70-75/ 95-102			
B 18 E	1721	4	81.00	Injection, SOHC		75/102			
B 18 EP	1721	4	81.00			75/102			
480 Coupe 1.7L Turbo					08/87 → 07/96	33	BX080 (Fibre) (30-027127-00)	DL916 (21-27127-20/0)	EL960 [8] (22-27574-00/0)
B 18 FT	1721	4	81.00	SOHC		88/120			
480 Coupe 2.0L					08/92 → 09/95	34	BX600 (Fibre) (30-027850-00)	DX600 (21-27850-20/0)	
B 20 F	1998	4	82.70	SOHC		80-85/ 108- 115			
740 2.0L					01/85 → 08/92	35	BD070 (Fibre) (30-026435-00)	DD073 (21-26435-22/0)	EH445 (22-24158-04/0)
B 200 G	1986	4	88.90			80-89/ 109- 121			
B 200 F	1986	4	88.90	Injection, SOHC		82/111			
B 200 E	1986	4	88.90	Injection, SOHC		82-87/ 112- 118			
B 200 ET	1986	4	88.90	Injection, SOHC		118/160			







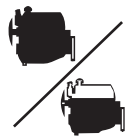



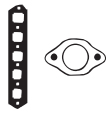

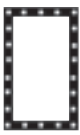

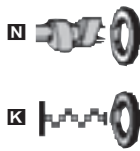







								
HBS244 ® (22-51103B) M12x1.50x111mm (x10)		JN732 (50-026632-00)	JH5011 (31-028402-00)	HR569 ® 24-30667-00/0	NF846 ® 25x42x7mm, FPM/ACM (50-319516-00) NF847 ® 22x45x7mm, FPM/ACM NF843 ® 50x68x10mm, FPM/ACM (50-305667-70) NF850 ® 85x105x8mm, FPM (50-319183-00)			 AY710, AY720, AY730  BD070  BL910  BX080  BX600  JB917  JC440  JD409  JD419  JD463  JE248  JN635  JN732  JH5011  JJ065  JJ557
HBS244 ® (22-51103B) M12x1.50x111mm (x10)	JD419 (31-027573-00)	JN732 (50-026632-00)	JJ557 KG5012 16x23x1.5mm	HR569 ® 24-30667-00/0	NF843 ® 50x68x10mm, FPM/ACM (50-305667-70) NF850 ® 85x105x8mm, FPM (50-319183-00)			
HBS120 ® (22-51008B) M12x1.50x118mm (x10)	JD463	JN555 JN732 (50-026632-00)	JH5011 (31-028402-00) KG5012 16x23x1.5mm	HR569 ® 24-30667-00/0	NF846 ® 25x42x7mm, FPM/ACM (50-319516-00) NF843 ® 50x68x10mm, FPM/ACM (50-305667-70) NF850 ® 85x105x8mm, FPM (50-319183-00)	HL5013 [245]® NF791 [38] KA625 [13] NF849 [15]		
HBS244 ® (22-51103B) M12x1.50x111mm (x10)	JD419 (31-027573-00)	JN732 (50-026632-00)	JH5011 (31-028402-00)	HR805 ®	NF846 ® 25x42x7mm, FPM/ACM (50-319516-00) NF847 ® 22x45x7mm, FPM/ACM NF843 ® 50x68x10mm, FPM/ACM (50-305667-70) NF850 ® 85x105x8mm, FPM (50-319183-00)			
HBS244 ® (22-51103B) M12x1.50x111mm (x10)	JD409 (31-026628-10)	JN732 (50-026632-00)	JJ557 PA349 (33-102290-10) 22x16x2mm	HR569 ® 24-30667-00/0	NF846 ® 25x42x7mm, FPM/ACM (50-319516-00) NF847 ® 22x45x7mm, FPM/ACM NF843 ® 50x68x10mm, FPM/ACM (50-305667-70) NF850 ® 85x105x8mm, FPM (50-319183-00)			
HBS244 ® (22-51103B) M12x1.50x111mm (x10)		JN732 (50-026632-00)	JH5011 (31-028402-00)	HR569 ® 24-30667-00/0	NF846 ® 25x42x7mm, FPM/ACM (50-319516-00) NF847 ® 22x45x7mm, FPM/ACM NF843 ® 50x68x10mm, FPM/ACM (50-305667-70) NF850 ® 85x105x8mm, FPM (50-319183-00)			
HBS244 ® (22-51103B) M12x1.50x111mm (x10)	JD419 (31-027573-00)	JN732 (50-026632-00)	JH5011 (31-028402-00)	HR805 ®	NF846 ® 25x42x7mm, FPM/ACM (50-319516-00) NF847 ® 22x45x7mm, FPM/ACM NF843 ® 50x68x10mm, FPM/ACM (50-305667-70) NF850 ® 85x105x8mm, FPM (50-319183-00)			
HBS174 ® (22-47001B) M12x1.75x133mm (x10)	JC440 ® (31-025331-10) JB917 ® (x4) (31-026434-00) JE248 (31-024200-10)	JN635 (31-026392-00)	JJ065 (31-024158-10)	HR641 ® (50-305909-00)	NA5016 35x47x7mm, FPM/ACM (50-305690-50) NA581 ® 52x68x10mm, MVQ (50-305276-00) NA869 ® 92x110x10mm, FPM (50-319023-10)	NA5016 [42]		



KW/PS

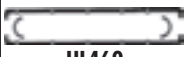

740 2.0L					09/88 → 08/90	36	BD070 (Fibre) (30-026435-00)	DD072	EH445 (22-24158-04/0)
B 200 K	1986	4	88.90	Carburettor, SOHC	70-77/ 95-105				
740 2.0L 16V					09/87 → 08/90	37	BX090 (Fibre) (30-027529-00)	DX090 (21-27529-20/0)	EH445 (22-24158-04/0)
740 2.0L GLE					09/87 → 08/90				
B 204 E	1986	4	88.90	Injection, DOHC	100- 103/ 136- 140				
740 2.3L					08/84 → 07/86	38	BK640 (Fibre) (30-024669-10)	DK642 (21-24669-26/0)	EH445 (22-24158-04/0)
B 230 A	2316	4	96.00	Carburettor	81-86/ 110- 117				
740 2.3L					08/84 → 07/92	39	BK640 (Fibre) (30-024669-10)	DK643 (21-24669-24/0)	EH445 (22-24158-04/0)
740 2.3L Turbo					08/85 → 12/88				
B 23 A	2316	4	96.00	Carburettor, SOHC	78-84/ 106- 114				
B 230 F	2316	4	96.00	Injection, SOHC	81-100/ 110- 136				
B 230 FB	2316	4	96.00	Injection, SOHC	96/131				
B 230 E	2316	4	96.00	Injection, SOHC	96-98/ 131- 133				
B 230 ET	2316	4	96.00	Injection, SOHC	134/182				
740 2.3L					08/87 → 08/92	40	BK640 (Fibre) (30-024669-10)	DK644 (21-24669-29/0)	
B 234 F	2316	4	96.00	Injection, DOHC	111- 117/ 151- 159				
740 2.3L					09/85 → 07/90	41			
B 230 K	2316	4	96.00	Carburettor, SOHC	85/116				
740 2.3L Turbo					08/86 → 07/90	42	BK640 (Fibre) (30-024669-10)	DK643 (21-24669-24/0)	EH445 (22-24158-04/0)
B 230 FT	2316	4	96.00	Injection, SOHC	115- 151/ 156- 205				
B 230 GT	2316	4	96.00	Injection	121/165				
740 2.4L D Diesel					08/84 → 07/92	43	BZ930 (MLS), 1.57mm, 2 Holes 30-028809-00 BW680 (Fibre), 1.53mm, 1 Notch Eng.41876 → BW690 (Fibre), 1.57mm, 2 Notches 30-027337-10 Eng.41876 → BW700 (Fibre), 1.61mm, 3 Notches Eng.41876 →	DM631▲ (21-24536-22/0) Eng.41876 →	EX980 22-27422-00/0
D 24	2383	6	76.50		58-60/ 79-82				











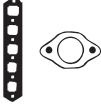

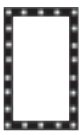

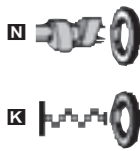













								
HBS174 ⊕ (22-47001B) M12x1.75x133mm (x10)	JC440 ■ (31-025331-10) JB917 ■ (x4) (31-026434-00) ⊙ JE248 (31-024200-10)	JN635 (31-026392-00)	JJ065 (31-024158-10)	HR641 ■ (50-305909-00)	NA5016 35x47x7mm, FPM/ACM (50-305690-50) NA581 ■ 52x68x10mm, MVQ (50-305276-00) NA869 ■ 92x110x10mm, FPM (50-319023-10)	NA5016 [42]		 BD070  BK640  BW680, BW690, BW700  BX090  BZ930  JB917  JC146  JC152  JC440  JD345  JD346  JE248  HL469  JN635  JJ065  JJ551
HBS175 ⊕ (22-47005B) M12x1.75x77mm (x3) M12x1.75x115mm (x7)	JD345 ■ (31-027293-00) JD346 ■ ⊙ JE248 (31-024200-10)	HM5293 ■ (24-26683-00/0)	JJ065 (31-024158-10)		NA581 ■ 52x68x10mm, MVQ (50-305276-00) NA869 ■ 92x110x10mm, FPM (50-319023-10)			
HBS174 ⊕ (22-47001B) M12x1.75x133mm (x10)	JC440 ■ (31-025331-10) JB917 ■ (x4) (31-026434-00) ⊙ JE248 (31-024200-10)	JN635 (31-026392-00)	JJ065 (31-024158-10)	HR641 ■ (50-305909-00)	NA5016 35x47x7mm, FPM/ACM (50-305690-50) NA581 ■ 52x68x10mm, MVQ (50-305276-00) NA869 ■ 92x110x10mm, FPM (50-319023-10)	NA5016 [42]		
HBS174 ⊕ (22-47001B) M12x1.75x133mm (x10)	JC440 ■ (31-025331-10) JB917 ■ (x4) (31-026434-00) ⊙ JE248 (31-024200-10)	JN635 (31-026392-00)	JJ065 (31-024158-10)	HR641 ■ (50-305909-00)	NA5016 35x47x7mm, FPM/ACM (50-305690-50) NA581 ■ 52x68x10mm, MVQ (50-305276-00) NA869 ■ 92x110x10mm, FPM (50-319023-10)	NA5016 [42]		
HBS175 ⊕ (22-47005B) M12x1.75x77mm (x3) M12x1.75x115mm (x7)	JD345 ■ (31-027293-00) JD346 ■ ⊙ JE248 (31-024200-10)	HL469 ■ 24-24042-00/0	JJ065 (31-024158-10)		NA5016 ■ 35x47x7mm, FPM/ACM (50-305690-50) NA581 ■ 52x68x10mm, MVQ (50-305276-00) NA869 ■ 92x110x10mm, FPM (50-319023-10)			
HBS174 ⊕ (22-47001B) M12x1.75x133mm (x10)	JC440 ■ (31-025331-10) JB917 ■ (x4) (31-026434-00) ⊙ JE248 (31-024200-10)	JN635 (31-026392-00)	JJ065 (31-024158-10)	HR641 ■ (50-305909-00)	NA5016 35x47x7mm, FPM/ACM (50-305690-50) NA581 ■ 52x68x10mm, MVQ (50-305276-00) NA869 ■ 92x110x10mm, FPM (50-319023-10)			
HBS174 ⊕ (22-47001B) M12x1.75x133mm (x10)	JC440 ■ (31-025331-10) JB917 ■ (x4) (31-026434-00) ⊙ JE248 (31-024200-10)	JN635 (31-026392-00)	JJ065 (31-024158-10)	HR641 ■ (50-305909-00)	NF846 ■ 25x42x7mm, FPM/ACM (50-319516-00) NA581 ■ 52x68x10mm, MVQ (50-305276-00) NA869 ■ 92x110x10mm, FPM (50-319023-10)			
HBS022 ⊕ (22-39005B) M12x1.75x115mm (x14)	JC146 ■ 31-024044-20 JC152 ■ (x6) 31-026555-00	HL469 ■ 24-24042-00/0 →02/81 →Eng.41875	JJ551 (31-024893-10)	HR805 ■	NA5001 32x47x10mm, FPM (50-303185-50) NB716 ■ 35x48x10mm, FPM (50-306067-50) NA5133 ■ 85x105x11mm, FPM (24-30727-87/0)			



KW/PS



740 2.4L TD Diesel				08/84 → 07/90	44	BW680 (Fibre), 1.53mm, 1 Notch BZ930 (MLS), 1.57mm, 2 Holes 30-028809-00 BW690 (Fibre), 1.57mm, 2 Notches 30-027337-10 BW700 (Fibre), 1.61mm, 3 Notches	DM660▲ 21-26537-21/0	EG920 (22-24893-01/0)
740 2.4L TD Interc. Diesel				08/86 → 07/88				
740 2.4L Turbo-D Diesel				09/85 → 07/92				
D 24 T	2383	6	76.50		79-82/ 107- 112	BW690 (Fibre), 1.57mm, 2 Notches 30-027337-10 BW700 (Fibre), 1.61mm, 3 Notches	DM660▲ 21-26537-21/0	EG920 (22-24893-01/0)
D 24 TIC	2383	6	76.50		85-95/ 115- 129			
760 2.3L				01/88 → 07/92	45	BK640 (Fibre) (30-024669-10)	DK643 (21-24669-24/0)	EH445 (22-24158-04/0)
B 230 FT	2316	4	96.00	Injection, SOHC	115- 151/ 156- 205			
760 2.3L Turbo				08/84 → 08/90	46	BK640 (Fibre) (30-024669-10)	DK643 (21-24669-24/0)	EH445 (22-24158-04/0)
B 230 ET	2316	4	96.00	Injection, SOHC	134/182			
760 2.4L D Diesel				01/82 → 07/92	47	BZ930 (MLS), 1.57mm, 2 Holes 30-028809-00 BW680 (Fibre), 1.53mm, 1 Notch Eng.41876 → BW690 (Fibre), 1.57mm, 2 Notches 30-027337-10 Eng.41876 → BW700 (Fibre), 1.61mm, 3 Notches Eng.41876 →	DM631▲ (21-24536-22/0) Eng.41876 →	EX980 22-27422-00/0
D 24	2383	6	76.50		58-60/ 79-82			
760 2.4L TD Interc. Diesel				08/87 → 07/92	48	BW680 (Fibre), 1.53mm, 1 Notch BZ930 (MLS), 1.57mm, 2 Holes 30-028809-00 BW690 (Fibre), 1.57mm, 2 Notches 30-027337-10 BW700 (Fibre), 1.61mm, 3 Notches	DM660▲ 21-26537-21/0	EG920 (22-24893-01/0)
760 2.4L Turbo-D Diesel				08/82 → 07/92				
D 24 T	2383	6	76.50		79-82/ 107- 112			
D 24 TIC	2383	6	76.50		85-95/ 115- 129			
850 2.0L				06/91 → 12/96	49	BY370 (Fibre) (30-027343-20)	DY370 (21-27343-20/0) 01/96 →	EY370 (22-27343-00/0)
850 2.0L Turbo				02/93 → 12/96				
B 5204 T	1984	5	81.00	MPi, DOHC	103/140			
B 5204 F	1984	5	81.00	MPi, DOHC	107/145			
B 5204 FT	1984	5	81.00	MPi, DOHC	150- 155/ 204- 211			
850 2.0L				08/94 → 12/96	50	BY370 (Fibre) (30-027343-20)	DY371 (21-27343-21/0)	EY370 (22-27343-00/0)
B 5202 S	1984	5	81.00	SOHC	93/126			

								
HBS022 ⊗ (22-39005B) M12x1.75x115mm (x14)	JC146 ■ 31-024044-20 JC152 ■ (x6) 31-026555-00	HL728 50-027932-00	JJ551 (31-024893-10)	HR805 ■	NA5001 32x47x10mm, FPM (50-303185-50) NB716 ■ 35x48x10mm, FPM (50-306067-50) NA5133 ■ 85x105x11mm, FPM (24-30727-87/0)			 BK640  BW680, BW690, BW700  BY370  BZ930
HBS174 ⊗ (22-47001B) M12x1.75x133mm (x10)	JC440 ■ (31-025331-10) JB917 ■ (x4) (31-026434-00) JE248 (31-024200-10)	JN635 (31-026392-00)	JJ065 (31-024158-10)	HR641 ■ (50-305909-00)	NF846 ■ 25x42x7mm, FPM/ACM (50-319516-00) NA581 ■ 52x68x10mm, MVQ (50-305276-00) NA869 ■ 92x110x10mm, FPM (50-319023-10)			 JA5037  JA5038  JA5040  JA5042  JB917
HBS174 ⊗ (22-47001B) M12x1.75x133mm (x10)	JC440 ■ (31-025331-10) JB917 ■ (x4) (31-026434-00)	JN635 (31-026392-00)	JJ065 (31-024158-10)	HR641 ■ (50-305909-00)	NA5016 35x47x7mm, FPM/ACM (50-305690-50) NA581 ■ 52x68x10mm, MVQ (50-305276-00) NA869 ■ 92x110x10mm, FPM (50-319023-10)			 JB917  JC146  JC152  JC440  JE248
HBS022 ⊗ (22-39005B) M12x1.75x115mm (x14)	JC146 ■ 31-024044-20 JC152 ■ (x6) 31-026555-00	HL469 ■ 24-24042-00/0 →02/81 →Eng.41875	JJ551 (31-024893-10)	HR805 ■	NA5001 32x47x10mm, FPM (50-303185-50) NB716 ■ 35x48x10mm, FPM (50-306067-50) NA5133 ■ 85x105x11mm, FPM (24-30727-87/0)			 JC146  JC152  JC440  JE248
HBS022 ⊗ (22-39005B) M12x1.75x115mm (x14)	JC146 ■ 31-024044-20 JC152 ■ (x6) 31-026555-00	HL728 50-027932-00	JJ551 (31-024893-10)	HR805 ■	NA5001 32x47x10mm, FPM (50-303185-50) NB716 ■ 35x48x10mm, FPM (50-306067-50) NA5133 ■ 85x105x11mm, FPM (24-30727-87/0)			 HL469  HL728
HBS303 ⊗ (22-47007B) M12x1.75x162mm (x12) →Eng.131034 HBS185 ⊗ (22-53012B) M12x1.75x157mm (x12) Eng.131035→	JA5043 ■ (31-028604-00) →12/95 JA5038 ■ (31-028597-00) 01/96→ JA5040 ■ (x5) (31-028657-00) HA5041 ■ ■ (24-28657-00/0)			HR5030 ■ (x2) (24-30676-76/0)	NA5138 ■ 44.5x57.2x6.75mm, FPM (50-319352-00) NA5136 ■ 30x47x7mm, NBR (50-319470-00) NA5018 ■ 35x47x5.6mm, FPM NA5017 ■ 98x110x8.5mm, FPM (50-319354-00)			 JN635  JJ065  JJ551
HBS185 ⊗ (22-53012B) M12x1.75x157mm (x12) HBS303 ⊗ (22-47007B) M12x1.75x162mm (x12)	JA5037 ■ (31-028599-00) JA5042 ■ (x5) (31-028656-00) HA5040 ■ ■ (24-28656-00/0)			HR5030 ■ (24-30676-76/0)	NA5138 ■ 44.5x57.2x6.75mm, FPM (50-319352-00) NA5149 ■ [235] 30x54x15mm, FPM (50-319447-00) NA5018 ■ 35x47x5.6mm, FPM NA5017 ■ 98x110x8.5mm, FPM (50-319354-00)			



KW/PS

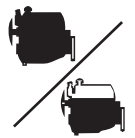

850 2.3L T5 02/93 → 12/96 51						BY370 (Fibre) (30-027343-20)	DY370 (21-27343-20/0) 01/96 →	
850 2.3L T5-R 08/95 → 12/96								
B 5234 FT	2319	5	81.00	MPi, DOHC	168/228			
B 5234 T4	2319	5	81.00	MPi, DOHC	176- 184/ 239- 250			
850 2.5L 06/91 → 12/96 52						BY360 (Fibre) (30-027344-20)	DY360 (21-27344-20/0)	EY370 (22-27343-00/0)
B 5252 S	2435	5	83.00		103/ 106/ 140/ 144			
B 5252	2435	5	83.00	Injection, DOHC	105/143			
850 2.5L 08/91 → 12/96 53						BY370 (Fibre) (30-027343-20)	DY370 (21-27343-20/0) 01/96 →	EY370 (22-27343-00/0)
850 2.5L AWD 04/96 → 12/96								
B 5254 S	2435	5	83.00	MPi, DOHC	125/ 142/ 170/ 193			
B 5254 T	2435	5	83.00	MPi, DOHC	142/ 154/ 193/ 210			
850 2.5L TDI Diesel 08/95 → 12/96 54						AF5310 (MLS), 1,51mm, 1 Hole 30-027510-40 AF5320 (MLS), 1,57mm, 2 Holes 30-027511-40 AF5330 (MLS), 1,61mm, 3 Holes 30-027512-40	DW861▲ (21-27510-20/0)	EW861 (22-27510-00/0)
D 5252 T	2401	5	81.00	SOHC	103/140			
940 2.0L 09/90 → 05/97 55						BX090 (Fibre) (30-027529-00)	DX090 (21-27529-20/0)	EH445 (22-24158-04/0)
940 2.0L GL 09/90 → 04/92								
B 204 E	1986	4	88.90	Injection, DOHC	100- 103/ 136- 140			
B 204 FT	1986	4	88.90	DOHC	147/200			
940 2.0L 01/92 → 07/94 56						BD070 (Fibre) (30-026435-00)	DD073 (21-26435-22/0)	EH445 (22-24158-04/0)
940 2.0L Turbo 01/91 → 10/98								
B 200 F	1986	4	88.90	Injection, SOHC	82/111			
B 200 FT	1986	4	88.90		105- 114/ 143- 155			
940 2.3L 08/90 → 07/91 57						BK640 (Fibre) (30-024669-10)	DK644 (21-24669-29/0)	
B 234 F	2316	4	96.00	Injection, DOHC	111- 117/ 151- 159			
B 234 G	2316	4	96.00	DOHC	114/155			

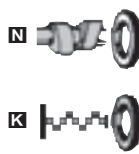
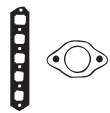

HBS303 (22-47007B) M12x1.75x162mm (x12) →Eng.131034 HBS185 (22-53012B) M12x1.75x157mm (x12) Eng.131035→	JA5043 (31-028604-00) →12/95 JA5038 (31-028597-00) 01/96→ JA5040E (x5) (31-028657-00) HA5041E (24-28657-00/0)			HR5030E (x2) (24-30676-76/0)	NA5138E 44.5x57.2x6.75mm, FPM (50-319352-00) NA5136E 30x47x7mm, NBR (50-319470-00) NA5018E 35x47x5.6mm, FPM NA5017E 98x110x8.5mm, FPM (50-319354-00)	
HBS303 (22-47007B) M12x1.75x162mm (x12) →Eng.131034 HBS185 (22-53012B) M12x1.75x157mm (x12) Eng.131035→	JA5037E (31-028599-00) JA5042E (x5) (31-028656-00)			HR5030E (x2) (24-30676-76/0)	NA5138E 44.5x57.2x6.75mm, FPM (50-319352-00) NA5149E [235] 30x54x15mm, FPM (50-319447-00) NA5018E 35x47x5.6mm, FPM NA5017E 98x110x8.5mm, FPM (50-319354-00)	
HBS303 (22-47007B) M12x1.75x162mm (x12) →Eng.131034 HBS185 (22-53012B) M12x1.75x157mm (x12) Eng.131035→	JA5043 (31-028604-00) →12/95 JA5038 (31-028597-00) 01/96→ JA5040E (x5) (31-028657-00) HA5041E (24-28657-00/0)			HR5030E (x2) (24-30676-76/0)	NA5138E 44.5x57.2x6.75mm, FPM (50-319352-00) NA5136E 30x47x7mm, NBR (50-319470-00) NA5018E 35x47x5.6mm, FPM NA5017E 98x110x8.5mm, FPM (50-319354-00)	
HBS021 (22-39003B) M12x1.75x115mm (x12)	JD312E 31-027043-00 JC152E (x5) 31-026555-00	JN967 50-027504-00	JJ501 (31-027042-00)	HR805E	NA5001 32x47x10mm, FPM (50-303185-50) NB716E 35x48x10mm, FPM (50-306067-50) NA5133E 85x105x11mm, FPM (24-30727-87/0)	
HBS175 (22-47005B) M12x1.75x77mm (x3) M12x1.75x115mm (x7)	JD345E (31-027293-00) JD346E	HM5293E (24-26683-00/0)	JJ065 (31-024158-10)		NA581E 52x68x10mm, MVQ (50-305276-00) NA869E 92x110x10mm, FPM (50-319023-10)	
HBS174 (22-47001B) M12x1.75x133mm (x10)	JC440E (31-025331-10) JB917E (x4) (31-026434-00) JE248 (31-024200-10)	JN635 (31-026392-00) HL469E 24-24042-00/0	JJ065 (31-024158-10)	HR641E (50-305909-00)	NA5016 35x47x7mm, FPM/ACM (50-305690-50) NA581E 52x68x10mm, MVQ (50-305276-00) NA869E 92x110x10mm, FPM (50-319023-10)	NA5016 [42]
HBS175 (22-47005B) M12x1.75x77mm (x3) M12x1.75x115mm (x7)	JD345E (31-027293-00) JD346E JE248 (31-024200-10)	HL469E 24-24042-00/0 HM5293E (24-26683-00/0)	JJ065 (31-024158-10)		NA5016E (x2) 35x47x7mm, FPM/ACM (50-305690-50) NA581E 52x68x10mm, MVQ (50-305276-00) NA869E 92x110x10mm, FPM (50-319023-10)	

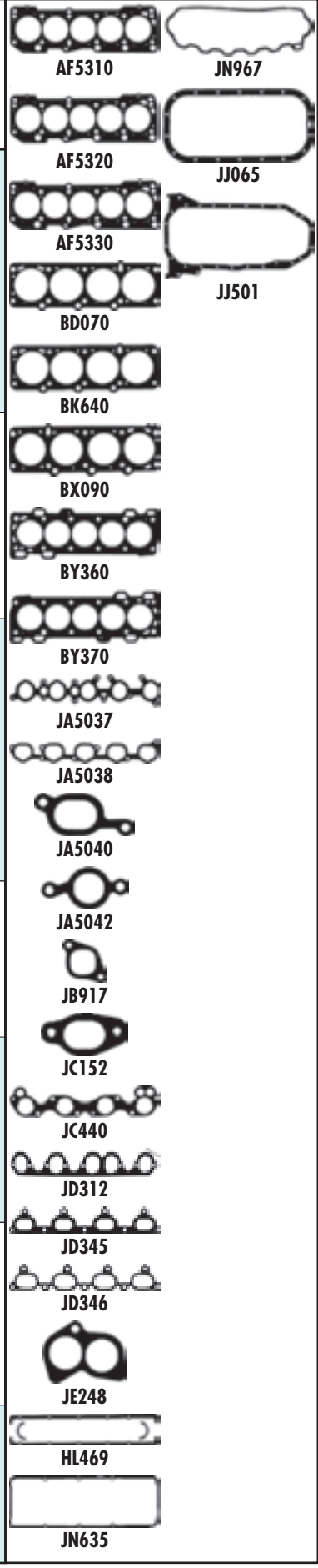









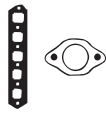

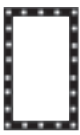

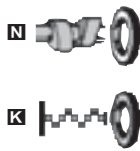













KW/PS

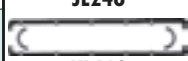

940 2.3L				08/90 → 10/98	58	BK640 (Fibre) (30-024669-10)	DK643 (21-24669-24/0)	EH445 (22-24158-04/0)		
940 2.3L ti				01/95 → 10/98						
940 2.3L Turbo				08/90 → 10/98						
B 230 FD	2316	4	96.00	Injection, SOHC	85-96/ 116- 131					
B 230 G	2316	4	96.00	Injection, SOHC	94-96/ 128- 131					
B 230 FB	2316	4	96.00	Injection, SOHC	96/131					
B 230 FK	2316	4	96.00	Injection, SOHC	99/135					
B 230 FT	2316	4	96.00	Injection, SOHC	115- 151/ 156- 205					
B 230 FT+	2316	4	96.00	Injection	140/190					
940 2.4L D Diesel				08/90 → 07/95	59	BZ930 (MLS), 1.57mm, 2 Holes 30-028809-00 BW680 (Fibre), 1.53mm, 1 Notch Eng.41876 → BW690 (Fibre), 1.57mm, 2 Notches 30-027337-10 Eng.41876 → BW700 (Fibre), 1.61mm, 3 Notches Eng.41876 →	DM631▲ (21-24536-22/0) Eng.41876 →	EX980 22-27422-00/0		
D 24	2383	6	76.50		58-60/ 79-82					
940 2.4L TD Interc. Diesel				08/94 → 10/98	60	BW680 (Fibre), 1.53mm, 1 Notch BZ930 (MLS), 1.57mm, 2 Holes 30-028809-00 BW690 (Fibre), 1.57mm, 2 Notches 30-027337-10 BW700 (Fibre), 1.61mm, 3 Notches	DM660▲ 21-26537-21/0	EG920 (22-24893-01/0)		
940 2.4L TD Intercooler Diesel				08/90 → 12/94						
940 2.4L Turbo-D Diesel				08/90 → 12/94						
D 24 T	2383	6	76.50		79-82/ 107- 112					
D 24 TIC	2383	6	76.50		85-95/ 115- 129					
960 2.0L				08/90 → 09/93	61	BX090 (Fibre) (30-027529-00)	DX090 (21-27529-20/0)			
B 204 FT	1986	4	88.90	DOHC	147/200					
960 2.0L				09/90 → 08/93	62	BX090 (Fibre) (30-027529-00)	DX090 (21-27529-20/0)	EH445 (22-24158-04/0)		
B 204 E	1986	4	88.90	Injection, DOHC	100- 103/ 136- 140					
960 2.4L TD Interc. Diesel				09/91 → 07/94	63	BW680 (Fibre), 1.53mm, 1 Notch BZ930 (MLS), 1.57mm, 2 Holes 30-028809-00 BW690 (Fibre), 1.57mm, 2 Notches 30-027337-10 BW700 (Fibre), 1.61mm, 3 Notches	DM660▲ 21-26537-21/0	EG920 (22-24893-01/0)		
D 24 TIC	2383	6	76.50		85-95/ 115- 129					
960 2.5L				08/94 → 12/96	64	AA5630 (Fibre) (30-028578-00)	CA5630 (21-28578-20/0)			
B 6254 S	2473	6	81.00	MPi, DOHC	125/170					

								
HBS174 Ⓢ (22-47001B) M12x1.75x133mm (x10)	JC440 ■ (31-025331-10) JB917 ■ (x4) (31-026434-00) JE248 (31-024200-10)	JN635 (31-026392-00)	JJ065 (31-024158-10)	HR641 ■ (50-305909-00)	NA NF846 ■ 25x42x7mm, FPM/ACM (50-319516-00) NA NF847 ■ 22x45x7mm, FPM/ACM NA NA581 ■ 52x68x10mm, MVQ (50-305276-00) NA NA869 ■ 92x110x10mm, FPM (50-319023-10)			 AA5630  BK640  BW680, BW690, BW700  BX090  BZ930  JA5040  JA5044  JB917  JC146  JC152  JC440  JD345  JD346  JE248  HL469  HL728  JN635  JJ065  JJ551
HBS022 Ⓢ (22-39005B) M12x1.75x115mm (x14)	JC146 ■ 31-024044-20 JC152 ■ (x6) 31-026555-00	HL469 ■ 24-24042-00/0 →02/81 →Eng.41875	JJ551 (31-024893-10)	HR805 ■	NA NA5001 32x47x10mm, FPM (50-303185-50) NA NB716 ■ 35x48x10mm, FPM (50-306067-50) NA NA5133 ■ 85x105x11mm, FPM (24-30727-87/0)			
HBS022 Ⓢ (22-39005B) M12x1.75x115mm (x14)	JC146 ■ 31-024044-20 JC152 ■ (x6) 31-026555-00	HL728 50-027932-00	JJ551 (31-024893-10)	HR805 ■	NA NA5001 32x47x10mm, FPM (50-303185-50) NA NB716 ■ 35x48x10mm, FPM (50-306067-50) NA NA5133 ■ 85x105x11mm, FPM (24-30727-87/0)			
HBS175 Ⓢ (22-47005B) M12x1.75x77mm (x3) M12x1.75x115mm (x7)	JD345 ■ (31-027293-00)	HM5293 ■ (24-26683-00/0)						
HBS175 Ⓢ (22-47005B) M12x1.75x77mm (x3) M12x1.75x115mm (x7)	JD345 ■ (31-027293-00) JD346 ■	HM5293 ■ (24-26683-00/0)	JJ065 (31-024158-10)		NA NA581 ■ 52x68x10mm, MVQ (50-305276-00) NA NA869 ■ 92x110x10mm, FPM (50-319023-10)			
HBS022 Ⓢ (22-39005B) M12x1.75x115mm (x14)	JC146 ■ 31-024044-20 JC152 ■ (x6) 31-026555-00	HL728 50-027932-00	JJ551 (31-024893-10)	HR805 ■	NA NA5001 32x47x10mm, FPM (50-303185-50) NA NB716 ■ 35x48x10mm, FPM (50-306067-50) NA NA5133 ■ 85x105x11mm, FPM (24-30727-87/0)			
	JA5044 ■ (31-028598-00) JA5040 ■ (x6) (31-028657-00) HA5042 ■ (24-28657-01/0)			HR5030 ■ (x2) (24-30676-76/0)	NA NA5138 ■ 44.5x57.2x6.75mm, FPM (50-319352-00) NA NA5136 ■ 30x47x7mm, NBR (50-319470-00) NA NA5018 ■ 35x47x5.6mm, FPM NA NA5017 ■ 98x110x8.5mm, FPM (50-319354-00)			



KW/PS



960 2.9L				08/90 → 07/94		65	AY260 (Fibre) (30-028579-00)	CY260■ (21-28579-20/0)	EY370 (22-27343-00/0)
B 6304 F	2922	6	83.00	Injection, DOHC		150/204			
960 2.9L				08/90 → 07/94		66	AY260 (Fibre) (30-028579-00)	CY260■ (21-28579-20/0)	EY370 (22-27343-00/0)
B 6304 F/B 6304 S	2922	6	83.00	Injection, DOHC		150/204			
960 2.9L				07/94 → 12/96		67	AY260 (Fibre) (30-028579-00)	CY260■ (21-28579-20/0)	EY370 (22-27343-00/0)
B 6304 S	2922	6	83.00	Injection, DOHC		150/204			
C30 1.6L				10/06 →		68	AG9560 (MLS) (30-030341-00)		EB5120
B 4164 S3	1596	4	79.00			74/100			
C30 2.0L D Diesel				10/06 →		69		CD5500▲	ED5500
D 4204 T	1998	4	85.00	Direct Injection		100/136			
C30 2.5L T5				10/06 →		70	AG8320 (MLS) (30-029272-00)		
B 5254 T3	2521	5	83.00	Injection, DOHC		162/220			
C70 Cabriolet 2.0L D Mk II Diesel				01/08 →		71		CD5500▲	ED5500
D 4204 T	1998	4	85.00	Direct Injection		100/136			
C70 Convertible 2.0L				03/98 → 10/05		72	BY370 (Fibre) (30-027343-20)	DY370 (21-27343-20/0)	EE5250 (22-29846-00/0)
C70 Coupe 2.0L				03/97 → 09/02					
B 5204 T2	1984	5	81.00	Injection, DOHC		132/180			

HBS426 (22-47009B) M12x1.75x162mm (x14) →12/93	JA5044 ■ (31-028598-00) JA5040 ■ (x6) (31-028657-00) HA5042 ■ ■ (24-28657-01/0)			HR5030 ■ (x2) (24-30676-76/0)	NA5138 ■ 44.5x57.2x6.75mm, FPM (50-319352-00) NA5136 ■ 30x47x7mm, NBR (50-319470-00) NA5018 ■ 35x47x5.6mm, FPM NA5017 ■ 98x110x8.5mm, FPM (50-319354-00)			AY260 BY370 JA5038 JA5040 JA5044	
HBS426 (22-47009B) M12x1.75x162mm (x14) →12/93	JA5044 ■ (31-028598-00) JA5040 ■ (x6) (31-028657-00) HA5042 ■ ■ (24-28657-01/0)			HR5030 ■ (x2) (24-30676-76/0) →Eng.1818168 HR5076 ■ (x2) (24-31947-90/0) Eng.1818169→	NA5138 ■ 44.5x57.2x6.75mm, FPM (50-319352-00) NA5178 ■ 45x65x7mm, FPM/ACM (50-319480-00) B630453 NA5136 ■ 30x47x7mm, NBR (50-319470-00) NA5018 ■ 35x47x5.6mm, FPM NA5017 ■ 98x110x8.5mm, FPM (50-319354-00)				
	JA5044 ■ (31-028598-00) JA5040 ■ (x6) (31-028657-00) HA5042 ■ ■ (24-28657-01/0)			HR5030 ■ (x2) (24-30676-76/0)	NA5138 ■ 44.5x57.2x6.75mm, FPM (50-319352-00) NA5136 ■ 30x47x7mm, NBR (50-319470-00) NA5018 ■ 35x47x5.6mm, FPM NA5017 ■ 98x110x8.5mm, FPM (50-319354-00)				
	JD5866 ■ (50-030340-00) JD5865 ■ (31-030338-00)				NC048 ■ (x2) 37.2x52.35x6mm, FPM (50-319368-00) LK5004 ■ [3] 80x182x19.4mm, PTFE (50-307318-70)				
	JD5881 ■	HM5289 ■			NA5035 27x47x7mm, FPM (50-319474-00) NA5191 ■ 42x62x7mm, PTFE (50-319500-00) NA5192 ■ 90x110x7mm, PTFE (50-319501-00)				
HBS185 ⊕ (22-53012B) M12x1.75x157mm (x12) HBS303 ⊕ (22-47007B) M12x1.75x162mm (x12)					NA5178 ■ 45x65x7mm, FPM/ACM (50-319480-00) NA5018 ■ 35x47x5.6mm, FPM NA5017 ■ 98x110x8.5mm, FPM (50-319354-00)				
	JD5881 ■	HM5289 ■			NA5035 27x47x7mm, FPM (50-319474-00) NA5191 ■ 42x62x7mm, PTFE (50-319500-00) NA5192 ■ 90x110x7mm, PTFE (50-319501-00)				
HBS303 ⊕ (22-47007B) M12x1.75x162mm (x12) →Eng.131034 HBS185 ⊕ (22-53012B) M12x1.75x157mm (x12) Eng.131035→	JA5038 ■ (31-028597-00) JA5040 ■ (x5) (31-028657-00) HA5041 ■ ■ (24-28657-00/0)			HR5030 ■ (x2) (24-30676-76/0)	NA5138 ■ 44.5x57.2x6.75mm, FPM (50-319352-00) NA5136 ■ 30x47x7mm, NBR (50-319470-00) NA5018 ■ 35x47x5.6mm, FPM NA5017 ■ 98x110x8.5mm, FPM (50-319354-00)				



KW/PS



C70 Convertible 2.0L T		03/00 → 10/05			73	AB5440 (Fibre) (30-028682-00)	CB5440 (21-28682-20/0)	EE5250 (22-29846-00/0)
B 5204 T4	1984	5	81.00	Injection, DOHC	120/163			
C70 Convertible 2.0L T C70 Coupe 2.0L T		03/98 → 10/05 03/97 → 09/02			74	BY370 (Fibre) (30-027343-20) →12/99 AB5440 (Fibre) (30-028682-00) 01/00 →	DY370 (21-27343-20/0) →12/99 CB5440 (21-28682-20/0) 01/00 →	EE5250 (22-29846-00/0)
B 5204 T3	1984	5	81.00	Injection, DOHC	166/226			
C70 Coupe 2.0L T		03/00 → 09/02			75	AB5440 (Fibre) (30-028682-00)		EE5250 (22-29846-00/0)
B 5204 T4	1984	5	81.00	Injection, DOHC	120/163			
C70 Convertible 2.3L T5		07/02 → 10/05			76	AB5440 (Fibre) (30-028682-00)	CB5440 (21-28682-20/0) → Eng.1817652	EE5250 (22-29846-00/0)
B 5234 T9	2319	5	81.00	Injection, DOHC	180/245			
C70 Convertible 2.3L T-5 C70 Coupe 2.3L T-5		03/98 → 10/05 03/97 → 09/02			77	BY370 (Fibre) (30-027343-20) →12/99 AB5440 (Fibre) (30-028682-00) 01/00 →	DY370 (21-27343-20/0) →12/99	EE5250 (22-29846-00/0)
B 5234 T3	2319	5	81.00	MPi, DOHC	176/ 184/ 239/ 250			
C70 Convertible 2.4L C70 Convertible 2.4L i		03/06 → 03/06 →			78	AG8340 (Fibre) (30-029316-00)		
B 5244 S5	2435	5	83.00	Injection, DOHC	103/140			
B 5244 S4	2435	5	83.00	Injection, DOHC	125/170			

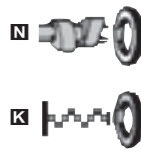
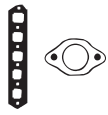

AB5440



BY370



JA5038



JA5040



KW/PS

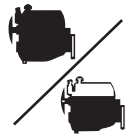

C70 Convertible 2.4L T		07/02 → 10/05		79		AB5440 (Fibre) (30-028682-00)		EE5250 (22-29846-00/0)	
B 5244 T	2435	5	83.00	Injection, DOHC	147/200				
C70 2.5L C70 Convertible 2.5L		03/99 → 09/02 06/98 → 10/05		80		BY360 (Fibre) (30-027344-20)		DY362 (21-27344-21/0) EY370 (22-27343-00/0)	
B 5254 S	2435 2435	5 5	83.00	MPi, DOHC	121/165 125/ 142/ 170/ 193				
C70 Convertible 2.5L T		03/98 → 10/05		81		BY360 (Fibre) (30-027344-20)		DY362 (21-27344-21/0) EE5250 (22-29846-00/0)	
B 5244 T	2435	5	83.00	MPi, DOHC	142/193				
B 5254 T	2435	5	83.00	MPi, DOHC	142/ 154/ 193/ 210				
C70 Convertible T5		03/06 →		82		AG8320 (MLS) (30-029272-00)			
B 5254 T3	2521	5	83.00	Injection, DOHC	162/220				
C70 Coupe 2.5L		11/99 → 09/02		83		BY360 (Fibre) (30-027344-20)		CB5451 DY362 (21-27344-21/0) EE5250 (22-29846-00/0)	
B 5244 S	2435	5	83.00	MPi, DOHC	125/170				
B 5254 S	2435	5	83.00		125/ 142/ 170/ 193				
C70 Coupe 2.5L T		03/97 → 09/02		84		AB5450 (Fibre) (30-028683-00) B 5244 T BY360 (Fibre) (30-027344-20) B 5254 T		DY362 (21-27344-21/0) B 5254 T EE5250 (22-29846-00/0)	
B 5244 T	2435	5	83.00	MPi, DOHC	142/193				
B 5254 T	2435	5	83.00	MPi, DOHC	142/ 154/ 193/ 210				
S40 1.6L Mk II		01/05 →		85		AG9560 (MLS) (30-030341-00)			EB5120
B 4164 S3	1596	4	79.00		74/100				
S40 1.6L		03/99 → 12/03		86		AB5430 (Fibre) (30-028681-00)		CE5130 (21-29818-20/0) → Eng.1818168 CE5131 (21-29818-21/0) Eng.1818169 → EA5620 (22-27376-00/0)	
B 4164 S2	1587	4	81.00	Injection, DOHC	80/109				

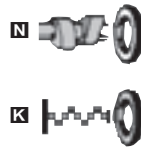
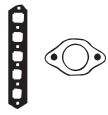

AB5430



AB5440



AB5450



BY360



JA5038



JA5040



JD5289

HBS185 (22-53012B)
M12x1.75x157mm (x12)

JD5288 (31-029809-00)
JA5040E (x5) (31-028657-00)
HA5041E (24-28657-00/0)

HR5076E (x2) (24-31947-90/0)

NA5178E 45x65x7mm, FPM/ACM (50-319480-00)
NA5179E 51x65x7mm, FPM (50-319481-00)
NA5136E 30x47x7mm, NBR (50-319470-00)
NA5018E 35x47x5.6mm, FPM
NA5017E 98x110x8.5mm, FPM (50-319354-00)

HBS303 (22-47007B)
M12x1.75x162mm (x12)
→Eng.131034

JA5038 (31-028597-00)
JA5040E (x5) (31-028657-00)

HR5030E (x2) (24-30676-76/0)
→Eng.1817652

HR5076E (x2) (24-31947-90/0)
Eng.1817653→

NA5138E 44.5x57.2x6.75mm, FPM (50-319352-00)
NA5136E 30x47x7mm, NBR (50-319470-00)
NA5018E 35x47x5.6mm, FPM
NA5017E 98x110x8.5mm, FPM (50-319354-00)

HBS185 (22-53012B)
M12x1.75x157mm (x12)
Eng.131035→

HBS303 (22-47007B)
M12x1.75x162mm (x12)
→Eng.131034

JA5038 (31-028597-00)
JD5288 (31-029809-00)

HR5030E (x2) (24-30676-76/0)
→Eng.1817652

HR5076E (x2) (24-31947-90/0)
Eng.1817653→

NA5138E 44.5x57.2x6.75mm, FPM (50-319352-00)
NA5136E 30x47x7mm, NBR (50-319470-00)
NA5018E 35x47x5.6mm, FPM
NA5017E 98x110x8.5mm, FPM (50-319354-00)

HBS185 (22-53012B)
M12x1.75x157mm (x12)
Eng.131035→

JA5040E (x5) (31-028657-00)

NA5273E (50-319334-00)

HBS303 (22-47007B)
M12x1.75x162mm (x12)
→Eng.131034

JA5038 (31-028597-00)
JD5288 (31-029809-00)

HR5030E (x2) (24-30676-76/0)
→Eng.1817652

HR5076E (x2) (24-31947-90/0)
Eng.1817653→

NA5138E 44.5x57.2x6.75mm, FPM (50-319352-00)
NA5136E 30x47x7mm, NBR (50-319470-00)
NA5018E 35x47x5.6mm, FPM
NA5017E 98x110x8.5mm, FPM (50-319354-00)

HBS185 (22-53012B)
M12x1.75x157mm (x12)
Eng.131035→

JA5040E (x5) (31-028657-00)

HBS303 (22-47007B)
M12x1.75x162mm (x12)
→Eng.131034

JA5038 (31-028597-00)
JD5288 (31-029809-00)

HR5030E (x2) (24-30676-76/0)
→Eng.1817652

HR5076E (x2) (24-31947-90/0)
Eng.1817653→

NA5138E 44.5x57.2x6.75mm, FPM (50-319352-00)
NA5136E 30x47x7mm, NBR (50-319470-00)
NA5018E 35x47x5.6mm, FPM
NA5017E 98x110x8.5mm, FPM (50-319354-00)

HBS185 (22-53012B)
M12x1.75x157mm (x12)
Eng.131035→

JA5040E (x5) (31-028657-00)

HBS178 (22-51009B)
M12x1.75x157mm (x10)

JD5866 (50-030340-00)
JD5865E (31-030338-00)

NC048 (x2) 37.2x52.35x6mm, FPM (50-319368-00)
LK5004E [3] 80x182x19.4mm, PTFE (50-307318-70)

HBS178 (22-51009B)
M12x1.75x157mm (x10)

JD5289 (31-029810-00)
JA5040E (x4) (31-028657-00)

HR5060E (24-30676-75/0)
→Eng.1818168

HR5076E (24-31947-90/0)
Eng.1818169→







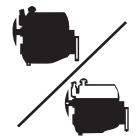



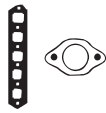

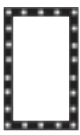



























































NA5178E 45x65x7mm, FPM/ACM (50-319480-00)
NA5179E 51x65x7mm, FPM (50-319481-00)
NA5136E 30x47x7mm, NBR (50-319470-00)
NA5018E 35x47x5.6mm, FPM
NA5017E 98x110x8.5mm, FPM (50-319354-00)



KW/PS



S40 1.6L		09/95 → 08/99			87	AA5620 (Fibre) [30-028374-00]	CA5620 [21-28374-20/0]	EA5620 [22-27376-00/0]
B 4164 S	1587	4	81.00	MPi, DOHC	80/109			
S40 1.8L		03/99 → 12/03			88	AB5420 (Fibre) [30-028680-00] B4184S2 AB5430 (Fibre) [30-028681-00] B4184S9	CB5420 [21-28680-20/0] B4184S2 (→1818168) CB5421 [21-28680-21/0] B4184S2 (1818169→) CE5130 [21-29818-20/0] B4184S9 (→1818168) CE5131 [21-29818-21/0] B4184S9 (1818169→)	EA5620 [22-27376-00/0]
B 4184 S9	1783	4	83.00	Injection, DOHC	88/90/ 120- 122			
B 4184 S2	1783	4	83.00	Injection	90/122			
S40 1.8L		04/04 →			89	AC5940 (MLS) [30-029554-00]	DW642 [16] [21-29554-20/0] DW643 [17] [21-29554-21/0]	ED5220 [22-29824-00/0]
B 4184 S11	1798	4	83.00	Injection	92/125			
S40 1.8L		07/95 → 08/99			90	AB5430 (Fibre) [30-028681-00] B4184S3 BX650 (Fibre) [30-027376-10] B4184S	CE5130 [21-29818-20/0] B4184S3 (→1818168) CE5131 [21-29818-21/0] B4184S3 (1818169→) DX652 [21-27376-21/0] B4184S	EA5620 [22-27376-00/0]
B 4184 S	1731	4	83.00	Injection, DOHC	85/116			
B 4184 S3	1731	4	83.00	Injection	85/116			
S40 1.8L i		03/98 → 12/03			91	AE5610 (MLS) →12/01 B4184SM	CE5612	FG7710 →12/01 B4184SM
B 4184 SM	1834	4	81.00	MPi, DOHC	92/125			
S40 1.8L i		06/01 → 12/03			92	AE5610 (MLS) B4184SJ		
B 4184 SJ	1834	4	81.00	Injection, DOHC	90/122			
S40 1.9L DI Diesel		03/99 → 07/00			93	AC5070 (Fibre), 1.35mm, 2 Notches [30-029474-00] →0.653mm AC5080 (Fibre), 1.45mm, 1 Notch [30-029475-00] →0.653→0.786mm AC5090 (Fibre), 1.55mm, 3 Notches [30-029476-00] →0.786mm→	CC5060▲ [21-29483-20/0]	EC5060 [22-29474-00/0]
D 4192 T2	1870	4	80.00	Direct Injection	70/95			
S40 1.9L DI Diesel		07/00 → 12/03			94	AC5061 (MLS), 1.32mm [30-029473-10]	CC5060▲ [21-29483-20/0]	EC5060 [22-29474-00/0]
D 4192 T4	1870	4	80.00	Direct Injection, DOHC	75/102			
D 4192 T3	1870	4	80.00	Direct Injection, DOHC	85/116			







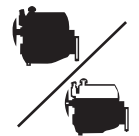



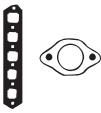

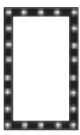

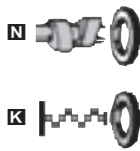





























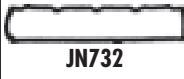

























      							
HBS178  (22-51009B) M12x1.75x157mm (x10)	JA5039  (31-029601-00) JA5040  (x4) (31-028657-00)			HR5060  (24-30676-75/0)	NA5138  44.5x57.2x6.75mm, FPM (50-319352-00) NA5136  30x47x7mm, NBR (50-319470-00) NA5018  35x47x5.6mm, FPM NA5017  98x110x8.5mm, FPM (50-319354-00)		 AA5620  AB5420  AB5430  AC5070, AC5080, AC5090  AC5940  BX650  JA5039  JA5040  JD5289  JD5299  JE5037
HBS178  (22-51009B) M12x1.75x157mm (x10)	JD5289  (31-029810-00) JA5040  (x4) (31-028657-00)			HR5060  (24-30676-75/0) →Eng.1818168 HR5076  (24-31947-90/0) Eng.1818169→	NA5178  45x65x7mm, FPM/ACM (50-319480-00) NA5179  51x65x7mm, FPM (50-319481-00) NA5136  30x47x7mm, NBR (50-319470-00) NA5018  35x47x5.6mm, FPM NA5017  98x110x8.5mm, FPM (50-319354-00)		
HBS369  (22-18095B) M10x1.50x145.5mm (x10)	JD5299  (50-029584-00) JE5037  [18] (31-029578-10)	JM5153 [17] (50-029582-00) JM5158 [16] (50-029577-00)		HR5063  (24-31945-10/0)	NA5157  37x50x8mm, PTFE (50-319442-00) LK5005  [3] 88x188x15mm, PTFE (50-319441-00)		
HBS178  (22-51009B) M12x1.75x157mm (x10)	JA5039  (31-029601-00) B41845 B418453 (→1818168) JD5289  (31-029810-00) B418453 (1818169→) JA5040  (x4) (31-028657-00)			HR5060  (24-30676-75/0) B41845 B418453 (→1818168) HR5076  (24-31947-90/0) B418453 (1818169→)	NA5138  44.5x57.2x6.75mm, FPM (50-319352-00) NA5179  51x65x7mm, FPM (50-319481-00) B418453 NA5136  30x47x7mm, NBR (50-319470-00) NA5018  35x47x5.6mm, FPM NA5017  98x110x8.5mm, FPM (50-319354-00)		
HBS215  (22-76001B) M10x1.25x95mm (x10)		JM5232 →12/01 B41845M			NJ874  37x50x6mm, ACM NK143  85x103x8mm, FPM		
HBS215  (22-76001B) M10x1.25x95mm (x10)		JM5290 JM5291			NJ874  37x50x6mm, ACM NK143  85x103x8mm, FPM		
HBS120  (22-51008B) M12x1.50x118mm (x10)	JD5189	JM5086	JH5041  KG5012 16x23x1.5mm	HR646  24-30670-60/0	NF846  25x42x7mm, FPM/ACM (50-319516-00) NA5036  42x54x6mm, FPM (50-319473-00) NA5133  85x105x11mm, FPM (24-30727-87/0)	HL5017 [245] 	
HBS244  (22-51103B) M12x1.50x111mm (x10)	JD5189	JM5086	JH5041  KG5012 16x23x1.5mm	HR646  24-30670-60/0	NF846  25x42x7mm, FPM/ACM (50-319516-00) NA5036  42x54x6mm, FPM (50-319473-00) NA5133  85x105x11mm, FPM (24-30727-87/0)	HL5017 [245] 	



KW/PS



S40 1.9L T4				05/97 → 07/00		95		
B 4194 T/B 4194 T2	1855	4	81.00	Injection, DOHC	147/200	AA5620 (Fibre) (30-028374-00) B4194T AB5430 (Fibre) (30-028681-00) B4194T2	CA5620 (21-28374-20/0) B4194T CE5130 (21-29818-20/0) B4194T2 (→1818168) CE5131 (21-29818-21/0) B4194T2 (1818169 →)	EA5620 (22-27376-00/0)
S40 1.9L TD Diesel				07/95 → 08/99		96		
D 4192 T	1870	4	80.00		66/89	AY710 (Steel Elastomer), 1.36mm, 2 Holes (30-029016-00) ☞→0.073mm AY720 (Steel Elastomer), 1.44mm, 1 Hole (30-029017-00) ☞0.073→0.206mm AY730 (Steel Elastomer), 1.52mm, 3 Holes (30-029018-00) ☞0.206mm→	DY040▲ (21-26632-23/0)	EL960 [8] (22-27574-00/0)
S40 2.0L D Mk II Diesel				01/04 →		97		
D 4204 T	1998	4	85.00	Direct Injection	100/136		CD5500▲	ED5500
S40 2.0L				07/95 → 12/03		98		
B 4204 S/B 4204 S2	1948	4	83.00	Injection, DOHC	100/136	AB5420 (Fibre) (30-028680-00) B4204S2 BX650 (Fibre) (30-027376-10) B4204S	CB5420 (21-28680-20/0) B4204S2 (→1818168) CB5421 (21-28680-21/0) B4204S2 (1818169 →) DX652 (21-27376-21/0) B4204S	EA5620 (22-27376-00/0)
S40 2.0L				07/95 → 08/99		99		
S40 2.0L T				10/97 → 07/00				
B 4204 S	1948	4	83.00	Injection, DOHC	100/136	BX650 (Fibre) (30-027376-10)	DX652 (21-27376-21/0)	EA5620 (22-27376-00/0)
B 4204 T	1948	4	83.00	Injection, DOHC	118/160			
S40 2.0L T				07/00 → 12/03		100		
B 4204 T3	1948	4	83.00	Injection, DOHC	120-121/163-165	AB5420 (Fibre) (30-028680-00)	CB5420 (21-28680-20/0) →Eng.1818168 CB5421 (21-28680-21/0) Eng.1818169 →	EA5620 (22-27376-00/0)

													
HBS178  (22-51009B) M12x1.75x157mm (x10)	JA5039  (31-029601-00) B4194T JD5289  (31-029810-00) B4194T2 JA5040  (x4) (31-028657-00)			HR5060  (24-30676-75/0) B4194T B4194T2 (→1818168) HR5076  (24-31947-90/0) B4194T2 (1818169→)	NA5136  30x47x7mm, NBR (50-319470-00) NA5138  44.5x57.2x6.75mm, FPM (50-319352-00) NA5018  35x47x5.6mm, FPM NA5017  98x110x8.5mm, FPM (50-319354-00)							AA5620  AB5420  AB5430  AY710, AY720, AY730 	
HBS120  (22-51008B) M12x1.50x118mm (x10)	JD463	JN555 JN732 (50-026632-00)	JH5011 (31-028402-00) KG5012 16x23x1.5mm	HR569  24-30667-00/0	NF846  25x42x7mm, FPM/ACM (50-319516-00) NF843  50x68x10mm, FPM/ACM (50-305667-70) NF850  85x105x8mm, FPM (50-319183-00)	HL5013 [245]  NF791 [38] KA625 [13] NF849 [15]					 BX650  JA5039  JA5040 		
	JD5881 	HM5289 			NA5035 27x47x7mm, FPM (50-319474-00) NA5191  42x62x7mm, PTFE (50-319500-00) NA5192  90x110x7mm, PTFE (50-319501-00)						 JD463  JD5289 		
HBS178  (22-51009B) M12x1.75x157mm (x10)	JA5039  (31-029601-00) B4204S JD5289  (31-029810-00) B4204S2 JA5040  (x4) (31-028657-00)			HR5060  (24-30676-75/0) →Eng.1818168 HR5076  (24-31947-90/0) Eng.1818169→	NA5138  44.5x57.2x6.75mm, FPM (50-319352-00) B4204S NA5178  45x65x7mm, FPM/ACM (50-319480-00) B4204S2 NA5179  51x65x7mm, FPM (50-319481-00) B4204S2 NA5136  30x47x7mm, NBR (50-319470-00) B4204S NA5018  35x47x5.6mm, FPM NA5017  98x110x8.5mm, FPM (50-319354-00)					 JN732 			
HBS178  (22-51009B) M12x1.75x157mm (x10)	JA5039  (31-029601-00) JA5040  (x4) (31-028657-00)			HR5060  (24-30676-75/0) →Eng.1818168 HR5076  (24-31947-90/0) Eng.1818169→	NA5138  44.5x57.2x6.75mm, FPM (50-319352-00) NA5136  30x47x7mm, NBR (50-319470-00) NA5018  35x47x5.6mm, FPM NA5017  98x110x8.5mm, FPM (50-319354-00)								
HBS178  (22-51009B) M12x1.75x157mm (x10)	JD5289  (31-029810-00) JA5040  (x4) (31-028657-00)			HR5060  (24-30676-75/0) →Eng.1818168 HR5076  (24-31947-90/0) Eng.1818169→	NA5178  45x65x7mm, FPM/ACM (50-319480-00) NA5179  51x65x7mm, FPM (50-319481-00) NA5136  30x47x7mm, NBR (50-319470-00) NA5018  35x47x5.6mm, FPM NA5017  98x110x8.5mm, FPM (50-319354-00)								



KW/PS



S40 2.0L T4				07/00 → 12/03		101	AB5420 (Fibre)	CB5420	
B 4204 T5	1948	4	83.00	Injection, DOHC		147/200	(30-028680-00)	(21-28680-20/0) → Eng.1818168	
								CB5421	
								(21-28680-21/0) Eng.1818169 →	
S40 2.4L				01/04 →		102	AG8340 (Fibre)		
B 5244 S5	2435	5	83.00	Injection, DOHC		103/140	(30-029316-00)		
S40 2.5L T5				01/04 →		103	AG8320 (MLS)		
S40 2.5L T5 AWD				04/04 →			(30-029272-00)		
B 5254 T3	2521	5	83.00	Injection, DOHC		162/220			
S60 2.0L T				09/01 →		104	AB5440 (Fibre)	CB5440	EE5250
B 5204 T5	1984	5	81.00	Injection, DOHC		132/180	(30-028682-00)	(21-28682-20/0)	(22-29846-00/0)
S60 2.3L T5				11/00 →		105	AB5440 (Fibre)	CB5440	EE5250
B 5234 T3	2319	5	81.00	MPi, DOHC		176/ 184/ 239/ 250	(30-028682-00)	(21-28682-20/0) → Eng.1817652	(22-29846-00/0)
S60 2.4L				11/00 →		106	AB5450 (Fibre)	CB5451	
B 5244 S2	2435	5	83.00			103/140	(30-028683-00) Eng.1817653 →		
S60 2.4L				11/00 →		107	AB5450 (Fibre)	CB5451	EE5250
B 5244 S	2435	5	83.00			125/170	(30-028683-00) Eng.1817653 →		(22-29846-00/0)
S60 2.4L AWD				02/04 →		108	AB5440 (Fibre)	CB5440	EE5250
B 5244 T5	2401	5	81.00	Injection		191/260	(30-028682-00)	(21-28682-20/0)	(22-29846-00/0)

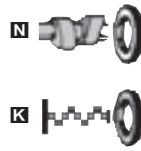
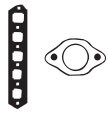

AB5420



AB5440



AB5450



JA5040



JD5289

HBS178
(22-51009B)
M12x1.75x157mm (x10)

JD5289
(31-029810-00)
JA5040 (x4)
(31-028657-00)

HR5060
(24-30676-75/0)
→Eng.1818168
HR5076
(24-31947-90/0)
Eng.1818169→

NA5178 45x65x7mm, FPM/ACM
(50-319480-00)
NA5179 51x65x7mm, FPM
(50-319481-00)
NA5136 30x47x7mm, NBR
(50-319470-00)
NA5018 35x47x5.6mm, FPM
NA5017 98x110x8.5mm, FPM
(50-319354-00)

HBS185
(22-53012B)
M12x1.75x157mm (x12)

HBS185
(22-53012B)
M12x1.75x157mm (x12)

NA5273
(50-319334-00)

HBS185
(22-53012B)
M12x1.75x157mm (x12)
→Eng.131034
HBS303
(22-47007B)
M12x1.75x162mm (x12)
Eng.131035→

JD5288
(31-029809-00)
JA5040 (x5)
(31-028657-00)
HA5041
(24-28657-00/0)

HR5030 (x2)
(24-30676-76/0)

NA5178 45x65x7mm, FPM/ACM
(50-319480-00)
NA5179 51x65x7mm, FPM
(50-319481-00)
NA5136 30x47x7mm, NBR
(50-319470-00)
NA5018 35x47x5.6mm, FPM
NA5017 98x110x8.5mm, FPM
(50-319354-00)

HBS185
(22-53012B)
M12x1.75x157mm (x12)
HBS303
(22-47007B)
M12x1.75x162mm (x12)

JD5288
(31-029809-00)
JA5040 (x5)
(31-028657-00)

HR5030 (x2)
(24-30676-76/0)
→Eng.1817652
HR5076 (x2)
(24-31947-90/0)
Eng.1817653→

NA5138 44.5x57.2x6.75mm, FPM
(50-319352-00)
NA5136 30x47x7mm, NBR
(50-319470-00)
NA5018 35x47x5.6mm, FPM
NA5017 98x110x8.5mm, FPM
(50-319354-00)

HBS185
(22-53012B)
M12x1.75x157mm (x12)

JD5288
(31-029809-00)
JA5040 (x5)
(31-028657-00)
HA5041
(24-28657-00/0)

HR5030 (x2)
(24-30676-76/0)
→Eng.1817652
HR5076 (x2)
(24-31947-90/0)
Eng.1817653→

NA5178 45x65x7mm, FPM/ACM
(50-319480-00)
NA5179 51x65x7mm, FPM
(50-319481-00)
NA5136 30x47x7mm, NBR
(50-319470-00)
NA5018 35x47x5.6mm, FPM
NA5017 98x110x8.5mm, FPM
(50-319354-00)

HBS185
(22-53012B)
M12x1.75x157mm (x12)

JD5288
(31-029809-00)
JA5040 (x5)
(31-028657-00)
HA5041
(24-28657-00/0)

HR5030 (x2)
(24-30676-76/0)
→Eng.1817652
HR5076 (x2)
(24-31947-90/0)
Eng.1817653→

NA5178 45x65x7mm, FPM/ACM
(50-319480-00)
NA5179 51x65x7mm, FPM
(50-319481-00)
NA5136 30x47x7mm, NBR
(50-319470-00)
NA5018 35x47x5.6mm, FPM
NA5017 98x110x8.5mm, FPM
(50-319354-00)

HR5030
(24-30676-76/0)
HR5076
(24-31947-90/0)

NA5273
(50-319334-00)



KW/PS



S60 2.4L Bifuel					06/02 →	109	AB5450 (Fibre) (30-028683-00) Eng.1817653 →		
B 5244 S62	2435	5	83.00	Injection, DOHC		103/140			
S60 2.4L D Diesel					12/01 →	110	AE5260 (MLS), 1.02mm, 1 Hole (30-029847-00)		
S60 2.4L D5 Diesel					07/01 →		AE5270 (MLS), 1.07mm, 2 Holes (30-029848-00)		
D 5244 T2	2401	5	81.00	Direct Injection, DOHC, V5		96-120/ 131- 163	AE5280 (MLS), 1.12mm, 3 Holes (30-029849-00)		
D 5244 T	2401	5	81.00	Common Rail		120/163	AE5290 (MLS), 1.17mm, 4 Holes (30-029850-00)		
							AE5300 (MLS), 1.27mm, 5 Holes (30-029851-00)		
S60 2.4L T					11/00 →	111	AB5450 (Fibre) (30-028683-00) Eng.1817653 →		EE5250 (22-29846-00/0)
S60 2.4L T AWD					11/01 →				
B 5244 T3	2435	5	83.00			147/200			
S60 2.4L T5					04/04 →	112	AB5440 (Fibre) (30-028682-00)	CB5440 (21-28682-20/0) →Eng.1817652	EE5250 (22-29846-00/0)
B 5244 T5	2401	5	81.00	Injection		191/260			
S60 2.5L T					02/04 →	113	AE5560 (MLS) (30-029110-00)		EE5250 (22-29846-00/0)
S60 2.5L T AWD					04/04 →				
S60 R 2.5L T AWD					03/03 →				
B 5254 T2	2521	5	83.00	Injection, DOHC		154/210			
B 5254 T4	2521	5	83.00	Injection, DOHC		220/300			
S70 2.0L					01/97 →11/00	114	BY370 (Fibre) (30-027343-20)	DY370 (21-27343-20/0)	EE5250 (22-29846-00/0)
B 5204 T4	1984	5	81.00	Injection, DOHC		120/163			
S70 2.0L					01/97 →11/00	115	BY370 (Fibre) (30-027343-20)	DY371 (21-27343-21/0)	EY370 (22-27343-00/0)
B 5202 S	1984	5	81.00	SOHC		93/126			

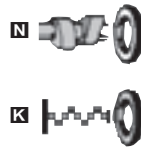
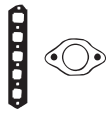

AB5440



AB5450



AE5270



AE5300



AE5560



BY370



JA5037



JA5038



JA5040



JA5042



KW/PS



S70 2.0L						01/97 → 11/00	116	BY370 (Fibre)	DY370	EY370
B 5204 F	1984	5	81.00	MPi, DOHC		107/145	(30-027343-20)	(21-27343-20/0)	(22-27343-00/0)	
S70 2.0L						01/97 → 11/00	117	BY370 (Fibre)	DY370	EE5250
B 5204 T2	1984	5	81.00	Injection, DOHC		132/180	(30-027343-20)	(21-27343-20/0)	(22-29846-00/0)	
S70 2.0L Turbo						01/97 → 11/00	118	BY370 (Fibre)	DY370	EY370
B 5204 T	1984	5	81.00	MPi, DOHC		103/140	(30-027343-20) →12/99 AB5440 (Fibre) (30-028682-00) 01/00→	(21-27343-20/0) →12/99 CB5440 (21-28682-20/0) 01/00→	(22-27343-00/0)	
S70 2.0L Turbo						01/97 → 11/00	119	BY370 (Fibre)	DY370	EE5250
B 5204 T3	1984	5	81.00	Injection, DOHC		166/226	(30-027343-20) →12/99 AB5440 (Fibre) (30-028682-00) 01/00→	(21-27343-20/0) →12/99 CB5440 (21-28682-20/0) 01/00→	(22-29846-00/0)	
S70 2.3L T-5						01/97 → 11/00	120	BY370 (Fibre)	DY370	EE5250
B 5234 T3	2319	5	81.00	MPi, DOHC		176/ 184/ 239/ 250	(30-027343-20) →12/99 AB5440 (Fibre) (30-028682-00) 01/00→	(21-27343-20/0) →12/99	(22-29846-00/0)	
S70 2.3L T5 AWD						11/96 → 09/98	121	BY370 (Fibre)	DY370	EE5250
B 5234 T3	2319	5	81.00	MPi, DOHC		176/ 184/ 239/ 250	(30-027343-20)	(21-27343-20/0)	(22-29846-00/0)	
S70 2.3L T5 AWD						07/97 → 09/00	122	BY370 (Fibre)	DY370	EY370
B 5234 T4	2319	5	81.00	MPi, DOHC		176- 184/ 239- 250	(30-027343-20) →12/99 AB5440 (Fibre) (30-028682-00) 01/00→	(21-27343-20/0) →12/99	(22-27343-00/0)	

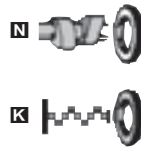
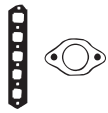

AB5440



BY370



JA5038



JA5040



KW/PS

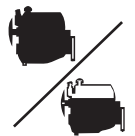

S70 2.3L Turbo					01/97 → 11/00	123	BY370 (Fibre) (30-027343-20) →12/99 AB5440 (Fibre) (30-028682-00) 01/00→	DY370 (21-27343-20/0) →12/99	EY370 (22-27343-00/0)
B 5234 FT+	2319	5	81.00	Injection		184/250			
S70 2.4L					08/99 → 11/00	124	AB5450 (Fibre) (30-028683-00) Eng.1817653→	CB5451	
B 5244 S2	2435	5	83.00	Injection, SOHC		103/140			
B 5244 SG	2435	5	83.00			103/140			
S70 2.4L					01/97 → 11/00	125	BY360 (Fibre) (30-027344-20)	CB5451 DY362 (21-27344-21/0)	EE5250 (22-29846-00/0)
B 5244 S	2435	5	83.00	MPi, DOHC		125/170			
B 5254 S	2435	5	83.00			125/ 142/ 170/ 193			
S70 2.4L Turbo					01/97 → 11/00	126	AB5450 (Fibre) (30-028683-00) B 5244 T BY360 (Fibre) (30-027344-20) B 5254 T	DY362 (21-27344-21/0) B 5254 T	EE5250 (22-29846-00/0)
B 5244 T	2435	5	83.00	MPi, DOHC		142/193			
B 5254 T	2435	5	83.00	MPi, DOHC		142/ 154/ 193/ 210			
S70 2.4L AWD					04/99 → 09/00	127		CB5451	
S70 2.4L Blu-Fuel					07/97 → 09/00				
B 5244 S2	2435	5	83.00	Injection, SOHC		103/140			
B 5244 SG	2435	5	83.00			103/140			
S70 2.4L AWD					04/99 → 09/00	128		CB5451	EE5250 (22-29846-00/0)
B 5244 S	2435	5	83.00			125/170			
S70 2.4L T5 AWD					11/96 → 04/99	129	BY360 (Fibre) (30-027344-20)	DY362 (21-27344-21/0)	EY370 (22-27343-00/0)
B 5254 T	2435	5	83.00	MPi, DOHC		142/ 154/ 193/ 210			
S70 2.5L TDi AWD Diesel					10/99 → 09/00	130	AF5310 (MLS), 1,51mm, 1 Hole 30-027510-40 AF5320 (MLS), 1,57mm, 2 Holes 30-027511-40 AF5330 (MLS), 1,61mm, 3 Holes 30-027512-40	DW861▲ (21-27510-20/0)	EW861 (22-27510-00/0)
S70 2.5L TDI Diesel					01/97 → 11/00				
D 5252 T	2401	5	81.00	SOHC		103/140			

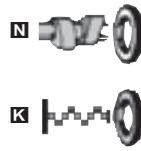
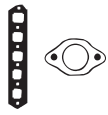

HBS303 (22-47007B) M12x1.75x162mm (x12) →Eng.131034 HBS185 (22-53012B) M12x1.75x157mm (x12) Eng.131035→	JA5038 (31-028597-00) →12/99 JD5288 (31-029809-00) 01/00→ JA5040 (x5) (31-028657-00) HA5041 (24-28657-00/0)			HR5030 (x2) (24-30676-76/0) →Eng.1817652 HR5076 (x2) (24-31947-90/0) Eng.1817653→	NA5138 44.5x57.2x6.75mm, FPM (50-319352-00) NA5136 30x47x7mm, NBR (50-319470-00) NA5018 35x47x5.6mm, FPM NA5017 98x110x8.5mm, FPM (50-319354-00)	
HBS185 (22-53012B) M12x1.75x157mm (x12)	JD5288 (31-029809-00) JA5040 (x5) (31-028657-00) HA5041 (24-28657-00/0)		HR5030 (x2) (24-30676-76/0) →Eng.1817652 HR5076 (x2) (24-31947-90/0) Eng.1817653→	NA5178 45x65x7mm, FPM/ACM (50-319480-00) NA5179 51x65x7mm, FPM (50-319481-00) NA5136 30x47x7mm, NBR (50-319470-00) NA5018 35x47x5.6mm, FPM NA5017 98x110x8.5mm, FPM (50-319354-00)		
HBS303 (22-47007B) M12x1.75x162mm (x12) →Eng.131034 HBS185 (22-53012B) M12x1.75x157mm (x12) Eng.131035→	JA5038 (31-028597-00) JA5040 (x5) (31-028657-00) HA5041 (24-28657-00/0)		HR5030 (x2) (24-30676-76/0) →Eng.1817652 HR5076 (x2) (24-31947-90/0) Eng.1817653→	NA5138 44.5x57.2x6.75mm, FPM (50-319352-00) NA5136 30x47x7mm, NBR (50-319470-00) NA5018 35x47x5.6mm, FPM NA5017 98x110x8.5mm, FPM (50-319354-00)		
HBS303 (22-47007B) M12x1.75x162mm (x12) →Eng.131034 HBS185 (22-53012B) M12x1.75x157mm (x12) Eng.131035→	JA5038 (31-028597-00) JD5288 (31-029809-00) JA5040 (x5) (31-028657-00)		HR5030 (x2) (24-30676-76/0) →Eng.1817652 HR5076 (x2) (24-31947-90/0) Eng.1817653→	NA5138 44.5x57.2x6.75mm, FPM (50-319352-00) NA5136 30x47x7mm, NBR (50-319470-00) NA5018 35x47x5.6mm, FPM NA5017 98x110x8.5mm, FPM (50-319354-00)		
HBS303 (22-47007B) M12x1.75x162mm (x12) →Eng.131034 HBS185 (22-53012B) M12x1.75x157mm (x12) Eng.131035→	JA5038 (31-028597-00) JA5040 (x5) (31-028657-00)		HR5030 (x2) (24-30676-76/0) →Eng.1817652 HR5076 (x2) (24-31947-90/0) Eng.1817653→	NA5138 44.5x57.2x6.75mm, FPM (50-319352-00) NA5136 30x47x7mm, NBR (50-319470-00) NA5018 35x47x5.6mm, FPM NA5017 98x110x8.5mm, FPM (50-319354-00)		
HBS021 (22-39003B) M12x1.75x115mm (x12)	JD312 (31-027043-00) JC152 (x5) (31-026555-00)	JN967 (50-027504-00)	JJ501 (31-027042-00)	HR805	NA5001 32x47x10mm, FPM (50-303185-50) NB716 35x48x10mm, FPM (50-306067-50) NA5133 85x105x11mm, FPM (24-30727-87/0)	

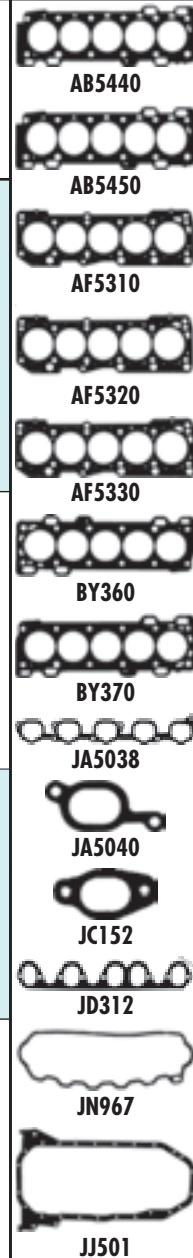



KW/PS



S70 2.5L		06/98 → 11/00			131	BY360 (Fibre) (30-027344-20)	DY362 (21-27344-21/0)	EY370 (22-27343-00/0)
	2435	5			121/165			
S70 2.5L		01/97 → 11/00			132	BY360 (Fibre) (30-027344-20)	DY360 (21-27344-20/0)	EY370 (22-27343-00/0)
B 5252 S	2435	5	83.00		103/ 106/ 140/ 144			
S70 2.5L Bifuel		10/98 → 11/00			133	BY360 (Fibre) (30-027344-20)		
GB 5252 S	2435	5	83.00	Injection	106/144			
S70 2.5L Bifuel		07/99 → 11/00			134	AB5450 (Fibre) (30-028683-00) Eng.1817653 →	CB5451	
B 5244 SG	2435	5	83.00	Injection, SOHC	103/140			
S80 2.0L Tdi Mk II Diesel		02/08 →			135		CD5500▲	ED5500
D 4204 T	1998	4	85.00	Direct Injection	100/136			
S80 2.0L		06/98 → 07/06			136	BY370 (Fibre) (30-027343-20) →12/99	DY370 (21-27343-20/0) →12/99	EE5250 (22-29846-00/0)
S80 2.0L T		06/98 → 07/06				AB5440 (Fibre) (30-028682-00) 01/00 →		
B 5204 T4	1984	5	81.00	Injection, DOHC	120/163			
B 5204 T3	1984	5	81.00	Injection, DOHC	166/226			
S80 2.0L T		12/99 → 07/06			137	AB5440 (Fibre) (30-028682-00)	CB5440 (21-28682-20/0)	EE5250 (22-29846-00/0)
B 5204 T5	1984	5	81.00	Injection, DOHC	132/180			
S80 2.3L R		04/00 → 08/05			138			EE5250 (22-29846-00/0)
B 5234 T7	2319	5	81.00	Injection, DOHC	195/265			
S80 2.4L		01/99 → 07/06			139	AB5450 (Fibre) (30-028683-00)	CB5451	EE5250 (22-29846-00/0)
B 5244 S	2435	5	83.00		125/170			

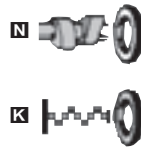
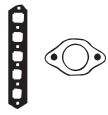

AB5440



AB5450



BY360



BY370

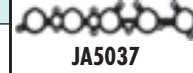

JA5037



JA5038



JA5040













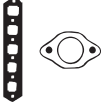

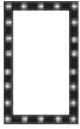

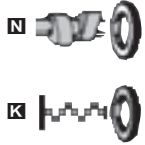





JA5042



KW/PS

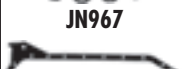

S80 2.4L				01/99 → 07/06	140	AB5450 (Fibre) (30-028683-00)	CB5451
B 5244 S2	2435	5	83.00		103/140		
S80 2.4L Bifuel				09/01 → 07/06	141	AB5450 (Fibre) (30-028683-00)	
B 5244 SG2	2435	5	83.00	Injection, DOHC	103/140		
S80 2.4L D Diesel				10/01 → 07/06	142	AE5260 (MLS), 1.02mm, 1 Hole (30-029847-00)	
S80 2.4L D5 Diesel				08/01 → 07/06		AE5270 (MLS), 1.07mm, 2 Holes (30-029848-00)	
D 5244 T2	2401	5	81.00	Direct Injection, DOHC, V5	96-120/ 131- 163	AE5280 (MLS), 1.12mm, 3 Holes (30-029849-00)	
D 5244 T	2401	5	81.00	Common Rail	120/163	AE5290 (MLS), 1.17mm, 4 Holes (30-029850-00)	
						AE5300 (MLS), 1.27mm, 5 Holes (30-029851-00)	
S80 2.4L T				06/00 → 07/06	143	AB5440 (Fibre) (30-028682-00)	EE5250 (22-29846-00/0)
B 5244 T3	2435	5	83.00		147/200		
S80 2.4L T5 AWD				04/00 → 09/03	144		EE5250 (22-29846-00/0)
B 5244 T3	2435	5	83.00		147/200		
S80 2.5L T AWD				07/03 → 07/06	145	AE5140 (Fibre) (30-029819-00)	EE5250 (22-29846-00/0)
B 5254 T2	2521	5	83.00	Injection, DOHC	154/210		
S80 2.5L TDI Diesel				01/99 → 07/06	146	AF5310 (MLS), 1,51mm, 1 Hole 30-027510-40	DW861▲ (21-27510-20/0)
D 5252 T	2401	5	81.00	SOHC	103/140	AF5320 (MLS), 1,57mm, 2 Holes 30-027511-40	EW861 (22-27510-00/0)
						AF5330 (MLS), 1,61mm, 3 Holes 30-027512-40	

								
HBS185 ⊕ (22-53012B) M12x1.75x157mm (x12)	JD5288 ■ (31-029809-00) JA5040 ■ (x5) (31-028657-00) HA5041 ■ ■ (24-28657-00/0)			HR5030 ■ (x2) (24-30676-76/0) →Eng.1817652 HR5076 ■ (x2) (24-31947-90/0) Eng.1817653→	NA5178 ■ 45x65x7mm, FPM/ACM (50-319480-00) NA5179 ■ 51x65x7mm, FPM (50-319481-00) NA5136 ■ 30x47x7mm, NBR (50-319470-00) NA5018 ■ 35x47x5.6mm, FPM NA5017 ■ 98x110x8.5mm, FPM (50-319354-00)			 AB5440  AB5450  AE5140  AE5270  AE5300  AF5310  AF5320  AF5330  JA5040  JC152  JD312  JN967  JJ501
HBS185 ⊕ (22-53012B) M12x1.75x157mm (x12)	JD5288 ■ (31-029809-00) JA5040 ■ (x5) (31-028657-00) HA5041 ■ ■ (24-28657-00/0)			HR5030 ■ (x2) (24-30676-76/0) →Eng.1817652 HR5076 ■ (x2) (24-31947-90/0) Eng.1817653→	NA5178 ■ 45x65x7mm, FPM/ACM (50-319480-00) NA5179 ■ 51x65x7mm, FPM (50-319481-00) NA5136 ■ 30x47x7mm, NBR (50-319470-00) NA5018 ■ 35x47x5.6mm, FPM NA5017 ■ 98x110x8.5mm, FPM (50-319354-00)			 NA5018 35x47x5.6mm, FPM  NA5017 98x110x8.5mm, FPM (50-319354-00)
HBS185 ⊕ (22-53012B) M12x1.75x157mm (x12)	JD5288 ■ (31-029809-00) JA5040 ■ (x5) (31-028657-00) HA5041 ■ ■ (24-28657-00/0)			HR5030 ■ (x2) (24-30676-76/0) →Eng.1817652 HR5076 ■ (x2) (24-31947-90/0) Eng.1817653→	NA5178 ■ 45x65x7mm, FPM/ACM (50-319480-00) NA5179 ■ 51x65x7mm, FPM (50-319481-00) NA5136 ■ 30x47x7mm, NBR (50-319470-00) NA5018 ■ 35x47x5.6mm, FPM NA5017 ■ 98x110x8.5mm, FPM (50-319354-00)			
				HR5030 ■ (x2) (24-30676-76/0) →Eng.1817652 HR5076 ■ (x2) (24-31947-90/0) Eng.1817653→	NA5138 ■ 44.5x57.2x6.75mm, FPM (50-319352-00) NA5136 ■ 30x47x7mm, NBR (50-319470-00) NA5018 ■ 35x47x5.6mm, FPM NA5017 ■ 98x110x8.5mm, FPM (50-319354-00)			
HBS185 ⊕ (22-53012B) M12x1.75x157mm (x12)	JD5288 ■ (31-029809-00) JA5040 ■ (x5) (31-028657-00) HA5041 ■ ■ (24-28657-00/0)			HR5076 ■ (x2) (24-31947-90/0)	NA5178 ■ 45x65x7mm, FPM/ACM (50-319480-00) NA5179 ■ 51x65x7mm, FPM (50-319481-00) NA5136 ■ 30x47x7mm, NBR (50-319470-00) NA5018 ■ 35x47x5.6mm, FPM NA5017 ■ 98x110x8.5mm, FPM (50-319354-00)			
HBS021 ⊕ (22-39003B) M12x1.75x115mm (x12)	JD312 ■ 31-027043-00 JC152 ■ (x5) 31-026555-00	JN967 50-027504-00	JJ501 (31-027042-00)	HR805 ■	NA5001 32x47x10mm, FPM (50-303185-50) NB716 ■ 35x48x10mm, FPM (50-306067-50) NA5133 ■ 85x105x11mm, FPM (24-30727-87/0)			



KW/PS



S80 2.8L T6				05/98 → 07/06		147	AE5170 (Fibre)	CA5640	EE5150
B 6284 T	2783	6	83.00			200/272	(30-029823-00)	→12/99 →Eng.1818168 CA5641 →12/99 Eng.1818169→ CE5170 01/00→12/01 →Eng.1818168 CE5171 01/00→12/01 Eng.1818169→ CE5160 01/02→ →Eng.1818168 CE5150 (21-29820-20/0) 01/02→ Eng.1818169→	
S80 2.9L				03/99 → 07/06		148	AE5160 (Fibre)		
B 6294 S	2922	6	83.00	Injection		147/200	(30-029821-00)		
S80 2.9L				05/98 → 07/06		149	AY260 (Fibre)	CY260■	EY370
B 6304 S3	2922	6	83.00	Injection, DOHC		150/204	(30-028579-00)	(21-28579-20/0)	(22-27343-00/0)
S80 3.0L				06/01 → 07/06		150	AE5160 (Fibre)		
B 6294 S2	2922	6	83.00	Injection, DOHC, V6		144/196	(30-029821-00)		
S80 3.0L T6				06/01 → 07/06		151	AE5150 (Fibre), 1.46mm	CE5150	EE5150
B 6294 T	2922	6	83.00	Injection, DOHC, V6		200/272	(30-029820-00) 03/03→	(21-29820-20/0)	
S90 2.9L				01/97 → 05/98		152	AY260 (Fibre)	CY260■	EY370
B 6304 S2	2922	6	83.00	Injection, DOHC		132/ 135/ 150/ 180/ 184/ 204	(30-028579-00)	(21-28579-20/0)	(22-27343-00/0)
B 6304 G	2922	6	83.00	Injection, DOHC		150/204			

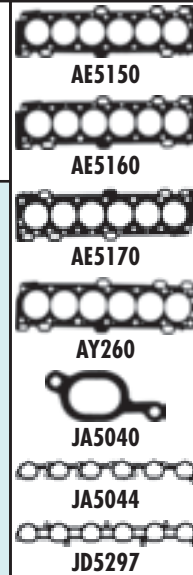
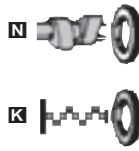
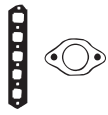

HBS426
(22-47009B)
M12x1.75x162mm (x14)

JD5898
(MLS)

NA5018 35x47x5.6mm, FPM
 NA5017 98x110x8.5mm, FPM
(50-319354-00)

HR5030 (x2)
(24-30676-76/0)
→Eng.1818168
 HR5076 (x2)
(24-31947-90/0)
Eng.1818169→

NA5138 44.5x57.2x6.75mm, FPM
(50-319352-00)
 NA5178 45x65x7mm, FPM/ACM
(50-319480-00)
 NA5136 30x47x7mm, NBR
(50-319470-00)
 NA5018 35x47x5.6mm, FPM
 NA5017 98x110x8.5mm, FPM
(50-319354-00)

JA5044
(31-028598-00)
JA5040 (x6)
(31-028657-00)
HA5042
(24-28657-01/0)

HR5030 (x2)
(24-30676-76/0)
→Eng.1818168
 HR5076 (x2)
(24-31947-90/0)
Eng.1818169→

NA5138 44.5x57.2x6.75mm, FPM
(50-319352-00)
 NA5178 45x65x7mm, FPM/ACM
(50-319480-00)
B630453
 NA5136 30x47x7mm, NBR
(50-319470-00)
 NA5018 35x47x5.6mm, FPM
 NA5017 98x110x8.5mm, FPM
(50-319354-00)

JD5297
(31-029822-00)
JA5040 (x6)
(31-028657-00)
HA5042
(24-28657-01/0)

HR5076 (x2)
(24-31947-90/0)

NA5178 45x65x7mm, FPM/ACM
(50-319480-00)
 NA5179 51x65x7mm, FPM
(50-319481-00)
 NA5136 30x47x7mm, NBR
(50-319470-00)
 NA5018 35x47x5.6mm, FPM
 NA5017 98x110x8.5mm, FPM
(50-319354-00)

JA5044
(31-028598-00)
JA5040 (x6)
(31-028657-00)
HA5042
(24-28657-01/0)

HR5030 (x2)
(24-30676-76/0)
→Eng.1818168
 HR5076 (x2)
(24-31947-90/0)
Eng.1818169→

NA5138 44.5x57.2x6.75mm, FPM
(50-319352-00)
 NA5178 45x65x7mm, FPM/ACM
(50-319480-00)
 NA5136 30x47x7mm, NBR
(50-319470-00)
 NA5018 35x47x5.6mm, FPM
 NA5017 98x110x8.5mm, FPM
(50-319354-00)



KWPS



V40 1.6L					03/99 → 06/04	153	AB5430 (Fibre) (30-028681-00)		CE5130 (21-29818-20/0) → Eng.1818168 CE5131 (21-29818-21/0) Eng.1818169 →	EA5620 (22-27376-00/0)
B 4164 S2	1587	4	81.00	Injection, DOHC		80/109				
V40 1.6L					12/95 → 08/99	154	AA5620 (Fibre) (30-028374-00)		CA5620 (21-28374-20/0)	EA5620 (22-27376-00/0)
B 4164 S	1587	4	81.00	MPi, DOHC		80/109				
V40 1.8L					03/99 → 06/04	155	AB5420 (Fibre) (30-028680-00) B418452 AB5430 (Fibre) (30-028681-00) B418459		CB5420 (21-28680-20/0) B418452 (→1818168) CB5421 (21-28680-21/0) B418452 (1818169 →) CE5130 (21-29818-20/0) B418459 (→1818168) CE5131 (21-29818-21/0) B418459 (1818169 →)	EA5620 (22-27376-00/0)
B 4184 S9	1783	4	83.00	Injection, DOHC		88-90/ 120- 122				
B 4184 S2	1783	4	83.00	Injection		90/122				
V40 1.8L					07/95 → 08/99	156	AB5430 (Fibre) (30-028681-00) B418453 BX650 (Fibre) (30-027376-10) B41845		CE5130 (21-29818-20/0) B418453 (→1818168) CE5131 (21-29818-21/0) B418453 (1818169 →) DX652 (21-27376-21/0) B41845	EA5620 (22-27376-00/0)
B 4184 S	1731	4	83.00	Injection, DOHC		85/116				
B 4184 S3	1731	4	83.00	Injection		85/116				
V40 1.8L i					03/98 → 06/04	157	AE5610 (MLS) →12/01		CE5612	FG7710 →12/01
B 4184 SM	1834	4	81.00	MPi, DOHC		92/125				
V40 1.8L i					06/01 → 06/04	158	AE5610 (MLS)			
B 4184 SJ	1834	4	81.00	Injection, DOHC		90/122				
V40 1.9L DI Diesel					03/99 → 07/00	159	AC5070 (Fibre), 1.35mm, 2 Notches (30-029474-00) →0.653mm AC5080 (Fibre), 1.45mm, 1 Notch (30-029475-00) →0.653 → 0.786mm AC5090 (Fibre), 1.55mm, 3 Notches (30-029476-00) →0.786mm →		CC5060▲ (21-29483-20/0)	EC5060 (22-29474-00/0)
D 4192 T2	1870	4	80.00	Direct Injection		70/95				
V40 1.9L DI Diesel					07/00 → 06/04	160	AC5061 (MLS), 1.32mm (30-029473-10)		CC5060▲ (21-29483-20/0)	EC5060 (22-29474-00/0)
D 4192 T4	1870	4	80.00	Direct Injection, DOHC		75/102				
D 4192 T3	1870	4	80.00	Direct Injection, DOHC		85/116				

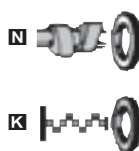
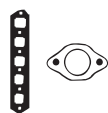

AA5620



AB5420



AB5430



AC5070, AC5080,
AC5090



BX650

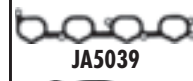

JA5039



JA5040



JD5289

HBS178⊕
(22-51009B)
M12x1.75x157mm (x10)

JD5289■
(31-029810-00)
JA5040■ (x4)
(31-028657-00)

HR5060■
(24-30676-75/0)
→Eng.1818168
HR5076■
(24-31947-90/0)
Eng.1818169→

NA5178■ 45x65x7mm, FPM/ACM
(50-319480-00)
NA5179■ 51x65x7mm, FPM
(50-319481-00)
NA5136■ 30x47x7mm, NBR
(50-319470-00)
NA5018■ 35x47x5.6mm, FPM
NA5017■ 98x110x8.5mm, FPM
(50-319354-00)

HBS178⊕
(22-51009B)
M12x1.75x157mm (x10)

JA5039■
(31-029601-00)
JA5040■ (x4)
(31-028657-00)

HR5060■
(24-30676-75/0)

NA5138■ 44.5x57.2x6.75mm, FPM
(50-319352-00)
NA5136■ 30x47x7mm, NBR
(50-319470-00)
NA5018■ 35x47x5.6mm, FPM
NA5017■ 98x110x8.5mm, FPM
(50-319354-00)

HBS178⊕
(22-51009B)
M12x1.75x157mm (x10)

JD5289■
(31-029810-00)
JA5040■ (x4)
(31-028657-00)

HR5060■
(24-30676-75/0)
→Eng.1818168
HR5076■
(24-31947-90/0)
Eng.1818169→

NA5178■ 45x65x7mm, FPM/ACM
(50-319480-00)
NA5179■ 51x65x7mm, FPM
(50-319481-00)
NA5136■ 30x47x7mm, NBR
(50-319470-00)
NA5018■ 35x47x5.6mm, FPM
NA5017■ 98x110x8.5mm, FPM
(50-319354-00)

HBS178⊕
(22-51009B)
M12x1.75x157mm (x10)

JA5039■
(31-029601-00)
B41845
B418453 (→1818168)
JD5289■
(31-029810-00)
B418453 (1818169→)
JA5040■ (x4)
(31-028657-00)

HR5060■
(24-30676-75/0)
B41845
B418453
(→1818168)
HR5076■
(24-31947-90/0)
B418453
(1818169→)

NA5138■ 44.5x57.2x6.75mm, FPM
(50-319352-00)
NA5179■ 51x65x7mm, FPM
(50-319481-00)
B418453
NA5136■ 30x47x7mm, NBR
(50-319470-00)
NA5018■ 35x47x5.6mm, FPM
NA5017■ 98x110x8.5mm, FPM
(50-319354-00)

HBS215⊕
(22-76001B)
M10x1.25x95mm (x10)

JM5232
→12/01

NJ874■ 37x50x6mm, ACM
NK143■ 85x103x8mm, FPM

HBS215⊕
(22-76001B)
M10x1.25x95mm (x10)

JM5290
JM5291

NJ874■ 37x50x6mm, ACM
NK143■ 85x103x8mm, FPM

HBS120⊕
(22-51008B)
M12x1.50x118mm (x10)

JD5189

JM5086

JH5041
● **KG5012**
16x23x1.5mm

HR646■
24-30670-60/0

NF846■ 25x42x7mm, FPM/ACM
(50-319516-00)
NA5036■ 42x54x6mm, FPM
(50-319473-00)
NA5133■ 85x105x11mm, FPM
(24-30727-87/0)

HL5017 [245]■

HBS244⊕
(22-51103B)
M12x1.50x111mm (x10)

JD5189

JM5086

JH5041
● **KG5012**
16x23x1.5mm

HR646■
24-30670-60/0

NF846■ 25x42x7mm, FPM/ACM
(50-319516-00)
NA5036■ 42x54x6mm, FPM
(50-319473-00)
NA5133■ 85x105x11mm, FPM
(24-30727-87/0)







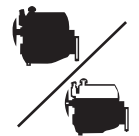



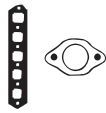

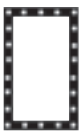

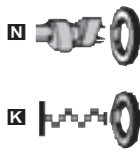

























































HL5017 [245]■



KW/PS



V40 1.9L T4				05/97 → 07/00		161	AA5620 (Fibre) (30-028374-00)	CA5620 (21-28374-20/0)	EA5620 (22-27376-00/0)
B 4194 T	1855	4	81.00	Injection, DOHC		147/200			
V40 1.9L TD Diesel				07/95 → 08/99		162	AY710 (Steel Elastomer), 1.36mm, 2 Holes (30-029016-00) → -0.073mm AY720 (Steel Elastomer), 1.44mm, 1 Hole (30-029017-00) → -0.073 → -0.206mm AY730 (Steel Elastomer), 1.52mm, 3 Holes (30-029018-00) → -0.206mm →	DY040▲ (21-26632-23/0)	EL960 [8] (22-27376-00/0)
D 4192 T	1870	4	80.00			66/89			
V40 2.0L D Diesel				12/02 → 06/04		163		CD5500▲	ED5500
D 4204 T	1998	4	85.00	Direct Injection		100/136			
V40 2.0L				07/95 → 06/04		164	BX650 (Fibre) (30-027376-10)	DX652 (21-27376-21/0)	EA5620 (22-27376-00/0)
V40 2.0L T				10/97 → 07/00					
B 4204 S	1948	4	83.00	Injection, DOHC		100/136			
B 4204 T	1948	4	83.00	Injection, DOHC		118/160			
V40 2.0L T				07/00 → 06/04		165	AB5420 (Fibre) (30-028680-00)	CB5420 (21-28680-20/0) → Eng.1818168 CB5421 (21-28680-21/0) Eng.1818169 →	EA5620 (22-27376-00/0)
V40 2.0L T4				07/00 → 06/04					
B 4204 T2	1948	4	83.00	Injection, DOHC		118- 121/ 160- 165			
B 4204 T3	1948	4	83.00	Injection, DOHC		120- 121/ 163- 165			
B 4204 T5	1948	4	83.00	Injection, DOHC		147/200			
V50 1.6L				01/05 →		166	AG9560 (MLS) (30-030341-00)		EB5120
B 4164 S3	1596	4	79.00			74/100			
V50 1.8L				04/04 →		167	AC5940 (MLS) (30-029554-00)	DW642 [16] (21-29554-20/0) DW643 [17] (21-29554-21/0)	ED5220 (22-29824-00/0)
B 4184 S11	1798	4	83.00	Injection		92/125			
V50 2.0L D Diesel				04/04 →		168		CD5500▲	ED5500
D 4204 T	1998	4	85.00	Direct Injection		100/136			
V50 2.4L				04/04 →		169	AG8340 (Fibre) (30-029316-00)		
B 5244 S5	2435	5	83.00	Injection, DOHC		103/140			

								
HBS178  (22-51009B) M12x1.75x157mm (x10)	JA5039  (31-029601-00) JA5040  (x4) (31-028657-00)			HR5060  (24-30676-75/0) B4194T B4194T2 (→1818168) HR5076  (24-31947-90/0) B4194T2 (1818169→)	NA5136  30x47x7mm, NBR (50-319470-00) NA5138  44.5x57.2x6.75mm, FPM (50-319352-00) NA5018  35x47x5.6mm, FPM NA5017  98x110x8.5mm, FPM (50-319354-00)			 AA5620  AB5420  AC5940  AY710, AY720, AY730  BX650  JA5039  JA5040  JD463  JD5289  JD5299  JE5037  JN732  JH5011
HBS120  (22-51008B) M12x1.50x118mm (x10)	JD463	JN732 (50-026632-00)	JH5011 (31-028402-00) KG5012 16x23x1.5mm	HR569  24-30667-00/0	NF846  25x42x7mm, FPM/ACM (50-319516-00) NF843  50x68x10mm, FPM/ACM (50-305667-70) NF850  85x105x8mm, FPM (50-319183-00)	HL5013 [245]  NF791 [38] KA625 [13] NF849 [15]		
	JD5881 	HM5289 						
HBS178  (22-51009B) M12x1.75x157mm (x10)	JA5039  (31-029601-00) JA5040  (x4) (31-028657-00)			HR5060  (24-30676-75/0) →Eng.1818168 HR5076  (24-31947-90/0) Eng.1818169→	NA5138  44.5x57.2x6.75mm, FPM (50-319352-00) NA5136  30x47x7mm, NBR (50-319470-00) NA5018  35x47x5.6mm, FPM NA5017  98x110x8.5mm, FPM (50-319354-00)			
HBS178  (22-51009B) M12x1.75x157mm (x10)	JD5289  (31-029810-00) JA5040  (x4) (31-028657-00)			HR5060  (24-30676-75/0) →Eng.1818168 HR5076  (24-31947-90/0) Eng.1818169→	NA5178  45x65x7mm, FPM/ACM (50-319480-00) NA5179  51x65x7mm, FPM (50-319481-00) NA5136  30x47x7mm, NBR (50-319470-00) NA5018  35x47x5.6mm, FPM NA5017  98x110x8.5mm, FPM (50-319354-00)			
HBS178  (22-51009B) M12x1.75x157mm (x10)	JD5866  (50-030340-00) JD5865  (31-030338-00)				NC048 (x2) 37.2x52.35x6mm, FPM (50-319368-00) LK5004 [3] 80x182x19.4mm, PTFE (50-307318-70)			
HBS369  (22-18095B) M10x1.50x145.5mm (x10)	JD5299  (50-029584-00) JE5037  [18] (31-029578-10)	JM5153 [17] (50-029582-00) JM5158 [16] (50-029577-00)		HR5063  (24-31945-10/0)	NA5157  37x50x8mm, PTFE (50-319442-00) LK5005 [3] 88x188x15mm, PTFE (50-319441-00)			
	JD5881 	HM5289 			NA5035 27x47x7mm, FPM (50-319474-00) NA5191  42x62x7mm, PTFE (50-319500-00) NA5192  90x110x7mm, PTFE (50-319501-00)			
HBS185  (22-53012B) M12x1.75x157mm (x12)					NA5178  45x65x7mm, FPM/ACM (50-319480-00) NA5179  51x65x7mm, FPM (50-319481-00) NA5018  35x47x5.6mm, FPM NA5017  98x110x8.5mm, FPM (50-319354-00)			



KW/PS



V50 2.4L				04/04 →	170	AB5450 (Fibre) (30-028683-00)	CB5451	EE5250 (22-29846-00/0)
B 5244 S	2435	5	83.00		125/170			
V50 2.5L T5				04/04 →	171	AG8320 (MLS) (30-029272-00)		
V50 2.5L T5 AWD				04/04 →				
B 5254 T3	2521	5	83.00	Injection, DOHC	162/220			
V70 2.0L D Mk III Diesel				10/07 →	172		CD5500▲	ED5500
D 4204 T	1998	4	85.00	Direct Injection	100/136			
V70 2.0L				01/97 →03/00	173	BY370 (Fibre) (30-027343-20)	DY370 (21-27343-20/0)	EE5250 (22-29846-00/0)
B 5204 T4	1984	5	81.00	Injection, DOHC	120/163			
V70 2.0L				01/97 →03/00	174	BY370 (Fibre) (30-027343-20)	DY371 (21-27343-21/0)	EY370 (22-27343-00/0)
B 5202 S	1984	5	81.00	SOHC	93/126			
V70 2.0L				01/97 →03/00	175	BY370 (Fibre) (30-027343-20)	DY370 (21-27343-20/0) 01/96 →	EY370 (22-27343-00/0)
	1984	5			105/143			
V70 2.0L				01/97 →03/00	176	BY370 (Fibre) (30-027343-20) AB5440 (Fibre) (30-028682-00) 01/00 →	DY370 (21-27343-20/0)	EE5250 (22-29846-00/0)
B 5204 T2	1984	5	81.00	Injection, DOHC	132/180			
V70 2.0L T				07/01 →	177	AB5440 (Fibre) (30-028682-00)		EE5250 (22-29846-00/0)
B 5204 T5	1984	5	81.00	Injection, DOHC	132/180			

HBS185 (22-53012B) M12x1.75x157mm (x12)				HR5030S (x2) (24-30676-76/0) →Eng.1817652 HR5076S (x2) (24-31947-90/0) Eng.1817653→	NA5138F 44.5x57.2x6.75mm, FPM (50-319352-00) NA5136F 30x47x7mm, NBR (50-319470-00) NA5018F 35x47x5.6mm, FPM NA5017F 98x110x8.5mm, FPM (50-319354-00)					AB5440 AB5450 BY370 JA5037 JA5038 JA5040 JA5042 	
HBS185 (22-53012B) M12x1.75x157mm (x12)					NA5273F (50-319334-00)						
	JD5881E	HM5289S			NA5035 27x47x7mm, FPM (50-319474-00) NA5191F 42x62x7mm, PTFE (50-319500-00) NA5192F 90x110x7mm, PTFE (50-319501-00)						
HBS303 (22-47007B) M12x1.75x162mm (x12) →Eng.131034 HBS185 (22-53012B) M12x1.75x157mm (x12) Eng.131035→	JA5038F (31-028597-00) JA5040F (x5) (31-028657-00) HA5041E S (24-28657-00/0)			HR5030S (x2) (24-30676-76/0)	NA5178F 45x65x7mm, FPM/ACM (50-319480-00) NA5179F 51x65x7mm, FPM (50-319481-00) NA5136F 30x47x7mm, NBR (50-319470-00) NA5018F 35x47x5.6mm, FPM NA5017F 98x110x8.5mm, FPM (50-319354-00)						
HBS185 (22-53012B) M12x1.75x157mm (x12) HBS303 (22-47007B) M12x1.75x162mm (x12)	JA5037F (31-028599-00) JA5042F (x5) (31-028656-00) HA5040E S (24-28656-00/0)			HR5030S (24-30676-76/0)	NA5138F 44.5x57.2x6.75mm, FPM (50-319352-00) NA5149F [235] 30x54x15mm, FPM (50-319447-00) NA5018F 35x47x5.6mm, FPM NA5017F 98x110x8.5mm, FPM (50-319354-00)						
HBS303 (22-47007B) M12x1.75x162mm (x12) →Eng.131034 HBS185 (22-53012B) M12x1.75x157mm (x12) Eng.131035→	JA5043F (31-028604-00) →12/95 JA5038F (31-028597-00) 01/96→ JA5040F (x5) (31-028657-00) HA5041E S (24-28657-00/0)			HR5030S (x2) (24-30676-76/0)	NA5149 (x2)[235] 30x54x15mm, FPM (50-319447-00) NA5138 (x2) 44.5x57.2x6.75mm, FPM (50-319352-00) NA5018F 35x47x5.6mm, FPM NA5017F 98x110x8.5mm, FPM (50-319354-00)						
HBS303 (22-47007B) M12x1.75x162mm (x12) →Eng.131034 HBS185 (22-53012B) M12x1.75x157mm (x12) Eng.131035→	JA5038F (31-028597-00) JA5040F (x5) (31-028657-00) HA5041E S (24-28657-00/0)			HR5030S (x2) (24-30676-76/0)	NA5138F 44.5x57.2x6.75mm, FPM (50-319352-00) NA5136F 30x47x7mm, NBR (50-319470-00) NA5018F 35x47x5.6mm, FPM NA5017F 98x110x8.5mm, FPM (50-319354-00)						
HBS303 (22-47007B) M12x1.75x162mm (x12) →Eng.131034 HBS185 (22-53012B) M12x1.75x157mm (x12) Eng.131035→	JA5038F (31-028597-00) JA5040F (x5) (31-028657-00) HA5041E S (24-28657-00/0)			HR5030S (x2) (24-30676-76/0)	NA5178F 45x65x7mm, FPM/ACM (50-319480-00) NA5179F 51x65x7mm, FPM (50-319481-00) NA5136F 30x47x7mm, NBR (50-319470-00) NA5018F 35x47x5.6mm, FPM NA5017F 98x110x8.5mm, FPM (50-319354-00)						



KW/PS

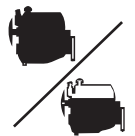

V70 2.0L Turbo					01/97 → 03/00	178	BY370 (Fibre) (30-027343-20) →12/99 AB5440 (Fibre) (30-028682-00) 01/00→	DY370 (21-27343-20/0) →12/99 CB5440 (21-28682-20/0) 01/00→	EY370 (22-27343-00/0)
B 5204 T	1984	5	81.00	MPI, DOHC		103/140			
V70 2.0L Turbo					01/97 → 03/00	179	BY370 (Fibre) (30-027343-20) →12/99 AB5440 (Fibre) (30-028682-00) 01/00→	DY370 (21-27343-20/0) →12/99 CB5440 (21-28682-20/0) 01/00→	EE5250 (22-29846-00/0)
B 5204 T3	1984	5	81.00	Injection, DOHC		166/226			
V70 2.0L Turbo AWD					01/97 → 03/00	180	BY370 (Fibre) (30-027343-20) →12/99 AB5440 (Fibre) (30-028682-00) 01/00→	DY370 (21-27343-20/0) →12/99	EE5250 (22-29846-00/0)
B 5204 T3	1984	5	81.00	Injection, DOHC		166/226			
V70 2.3L AWD Mk I					12/98 → 02/00	181			EE5250 (22-29846-00/0)
V70 2.3L AWD Mk II					10/00 → 09/04				
B 5234 T7/B 5234 T8	2319	5	81.00	Injection, DOHC		195/265			
V70 2.3L T AWD					04/97 → 03/00	182	BY370 (Fibre) (30-027343-20) →12/99 AB5440 (Fibre) (30-028682-00) 01/00→	DY370 (21-27343-20/0) →12/99	EY370 (22-27343-00/0)
V70 2.3L Turbo					01/97 → 03/00				
B 5234 FT+	2319	5	81.00	Injection		184/250			
V70 2.3L T5					03/00 →	183	AB5440 (Fibre) (30-028682-00)	CB5440 (21-28682-20/0) →Eng.1817652	EE5250 (22-29846-00/0)
B 5234 T3	2319	5	81.00	MPI, DOHC		176/ 184/ 239/ 250			
B 5234 T4	2319	5	81.00	MPI, DOHC		176- 184/ 239- 250			
V70 2.3L T5					01/97 → 03/00	184	BY370 (Fibre) (30-027343-20) →12/99 AB5440 (Fibre) (30-028682-00) 01/00→	DY370 (21-27343-20/0) →12/99	EE5250 (22-29846-00/0)
V70 2.3L T5 AWD					01/97 → 03/00				
B 5234 T3	2319	5	81.00	MPI, DOHC		176/ 184/ 239/ 250			

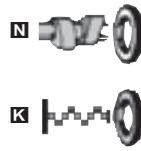
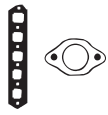

AB5440



BY370



JA5038



JA5040



KWPS



V70 2.3L AWD Mk I						04/97 → 09/98	185			EE5250 (22-29846-00/0)
V70 2.3L Mk II						10/00 → 09/04				
B 5234 T3	2319	5	81.00	MPi, DOHC		176/ 184/ 239/ 250				
B 5234 T7	2319	5	81.00	Injection, DOHC		195/265				
V70 2.4L						08/99 → 05/00	186	AB5450 (Fibre) (30-028683-00) Eng.1817653 →	CB5451	
B 5244 S2	2435	5	83.00			103/140				
B 5244 SG2	2435	5	83.00	Injection, DOHC		103/140				
V70 2.4L						03/00 →	187	AB5450 (Fibre) (30-028683-00) Eng.1817653 →	CB5451	
V70 2.4L Bifuel						08/99 → 03/00				
B 5244 S2	2435	5	83.00			103/140				
B 5244 SG	2435	5	83.00	Injection, SOHC		103/140				
V70 2.4L						03/00 →	188	AB5450 (Fibre) (30-028683-00) Eng.1817653 →	CB5451	EE5250 (22-29846-00/0)
B 5244 S	2435	5	83.00			125/170				
V70 2.4L						01/97 → 05/00	189	BY360 (Fibre) (30-027344-20)	DY362 (21-27344-21/0)	EY370 (22-27343-00/0)
B 5254 S	2435	5	83.00	MPi, DOHC		125/ 142/ 170/ 193				
V70 2.4L AWD Mk I						05/99 → 02/00	190			EE5250 (22-29846-00/0)
B 5244 T2	2435	5	83.00	Injection, DOHC		195/265				
V70 2.4L D Diesel						12/01 →	191	AE5260 (MLS), 1.02mm, 1 Hole (30-029847-00)		
V70 2.4L D5 Diesel						08/01 →		AE5270 (MLS), 1.07mm, 2 Holes (30-029848-00)		
V70 2.4L D5 AWD Diesel						03/03 →		AE5280 (MLS), 1.12mm, 3 Holes (30-029849-00)		
D 5244 T2	2401	5	81.00	Direct Injection, DOHC, V5		96-120/ 131- 163		AE5290 (MLS), 1.17mm, 4 Holes (30-029850-00)		
D 5244 T	2401	5	81.00	Common Rail		120/163		AE5300 (MLS), 1.27mm, 5 Holes (30-029851-00)		











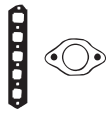

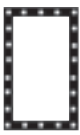

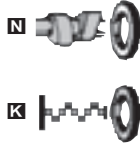































































HBS185 (22-53012B) M12x1.75x157mm (x12)	JD5288 (31-029809-00) JA5040 (x5) (31-028657-00)			HR5030 (x2) (24-30676-76/0) →Eng.1817652 HR5076 (x2) (24-31947-90/0) Eng.1817653→	NA5178 45x65x7mm, FPM/ACM (50-319480-00) NA5179 51x65x7mm, FPM (50-319481-00) NA5136 30x47x7mm, NBR (50-319470-00) NA5018 35x47x5.6mm, FPM NA5017 98x110x8.5mm, FPM (50-319354-00)					
HBS185 (22-53012B) M12x1.75x157mm (x12)	JD5288 (31-029809-00) JA5040 (x5) (31-028657-00) HA5041 (24-28657-00/0)			HR5030 (x2) (24-30676-76/0) →Eng.1817652 HR5076 (x2) (24-31947-90/0) Eng.1817653→	NA5178 45x65x7mm, FPM/ACM (50-319480-00) NA5179 51x65x7mm, FPM (50-319481-00) NA5136 30x47x7mm, NBR (50-319470-00) NA5018 35x47x5.6mm, FPM NA5017 98x110x8.5mm, FPM (50-319354-00)					
HBS185 (22-53012B) M12x1.75x157mm (x12)	JD5288 (31-029809-00) JA5040 (x5) (31-028657-00)			HR5030 (x2) (24-30676-76/0) →Eng.1817652 HR5076 (x2) (24-31947-90/0) Eng.1817653→	NA5178 45x65x7mm, FPM/ACM (50-319480-00) NA5179 51x65x7mm, FPM (50-319481-00) NA5136 30x47x7mm, NBR (50-319470-00) NA5018 35x47x5.6mm, FPM NA5017 98x110x8.5mm, FPM (50-319354-00)					
HBS303 (22-47007B) M12x1.75x162mm (x12) →Eng.131034 HBS185 (22-53012B) M12x1.75x157mm (x12) Eng.131035→	JA5038 (31-028597-00) JA5040 (x5) (31-028657-00) HA5041 (24-28657-00/0)			HR5030 (x2) (24-30676-76/0) →Eng.1817652 HR5076 (x2) (24-31947-90/0) Eng.1817653→	NA5138 44.5x57.2x6.75mm, FPM (50-319352-00) NA5136 30x47x7mm, NBR (50-319470-00) NA5018 35x47x5.6mm, FPM NA5017 98x110x8.5mm, FPM (50-319354-00)					
					NA5018 35x47x5.6mm, FPM NA5017 98x110x8.5mm, FPM (50-319354-00)					



KW/PS



V70 2.4L T					03/00 →	192	AB5450 (Fibre) (30-028683-00)		EE5250 (22-29846-00/0)
V70 2.4L T AWD					09/01 →				
B 5244 T3	2435	5	83.00			147/200			
V70 2.4L T5					04/04 →	193			EE5250 (22-29846-00/0)
B 5244 T5	2401	5	81.00	Injection		191/260			
V70 2.4L Turbo					01/97 →03/00	194	BY360 (Fibre) (30-027344-20) Eng.1817653 →	DY362 (21-27344-21/0)	EE5250 (22-29846-00/0)
B 5244 T	2435	5	83.00	MPi, DOHC		142/193			
B 5254 T	2435	5	83.00	MPi, DOHC		142/ 154/ 193/ 210			
V70 2.5L TDi AWD Mk I Diesel					11/96 →02/00	195	AF5310 (MLS), 1,51mm, 1 Hole 30-027510-40 AF5320 (MLS), 1,57mm, 2 Holes 30-027511-40 AF5330 (MLS), 1,61mm, 3 Holes 30-027512-40	DW861▲ (21-27510-20/0)	EW861 (22-27510-00/0)
V70 2.5L TDi Diesel					01/97 →05/00				
D 5252 T	2401	5	81.00	SOHC		103/140			
V70 2.5L					06/98 →03/00	196	BY360 (Fibre) (30-027344-20)	DY362 (21-27344-21/0)	EY370 (22-27343-00/0)
B 5254 F	2435	5	83.00	Injection, DOHC		125/170			
B 5254 S	2435	5	83.00	MPi, DOHC		125/ 142/ 170/ 193			
V70 2.5L					01/97 →03/00	197	BY360 (Fibre) (30-027344-20)	DY360 (21-27344-20/0)	EY370 (22-27343-00/0)
B 5252 S	2435	5	83.00			103/ 106/ 140/ 144			
V70 2.5L Bifuel					10/98 →08/99	198			
GB 5252 S	2435	5	83.00	Injection		106/144			
V70 2.5L T					04/04 →	199	AE5560 (MLS) (30-029110-00)		EE5250 (22-29846-00/0)
V70 R 2.5L T AWD					03/03 →				
B 5254 T2	2521	5	83.00	Injection, DOHC		154/210			
B 5254 T4	2521	5	83.00	Injection, DOHC		220/300			











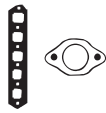

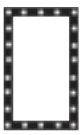

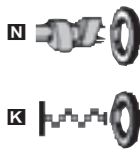





















































		      					
HBS185  [22-53012B] M12x1.75x157mm (x12)	JD5288  (31-029809-00)			HR5030  (x2) [24-30676-76/0] →Eng.1817652 HR5076  (x2) [24-31947-90/0] Eng.1817653→	NA5138  44.5x57.2x6.75mm, FPM (50-319352-00) NA5136  30x47x7mm, NBR (50-319470-00) NA5018  35x47x5.6mm, FPM NA5017  98x110x8.5mm, FPM (50-319354-00)		AB5450  AE5560  AF5310  AF5320  AF5330  BY360  JA5037  JA5038  JA5040  JA5042  JC152  JD312  JN967  JJ501 
HBS185  [22-53012B] M12x1.75x157mm (x12)				NA5273  (50-319334-00)			
HBS303  [22-47007B] M12x1.75x162mm (x12) →Eng.131034 HBS185  [22-53012B] M12x1.75x157mm (x12) Eng.131035→	JA5038  (31-028597-00) JD5288  (31-029809-00) JA5040  (x5) (31-028657-00)			HR5030  (x2) [24-30676-76/0] →Eng.1817652 HR5076  (x2) [24-31947-90/0] Eng.1817653→	NA5138  44.5x57.2x6.75mm, FPM (50-319352-00) NA5136  30x47x7mm, NBR (50-319470-00) NA5018  35x47x5.6mm, FPM NA5017  98x110x8.5mm, FPM (50-319354-00)		
HBS021  [22-39003B] M12x1.75x115mm (x12)	JD312  31-027043-00 JC152  (x5) 31-026555-00	JN967 50-027504-00	JJ501 (31-027042-00)	HR805 	NA5001  32x47x10mm, FPM (50-303185-50) NB716  35x48x10mm, FPM (50-306067-50) NA5133  85x105x11mm, FPM (24-30727-87/0)		
HBS303  [22-47007B] M12x1.75x162mm (x12) →Eng.131034 HBS185  [22-53012B] M12x1.75x157mm (x12) Eng.131035→	JA5038  (31-028597-00) JA5040  (x5) (31-028657-00)			HR5030  (x2) [24-30676-76/0]	NA5138  44.5x57.2x6.75mm, FPM (50-319352-00) NA5149  [235] 30x54x15mm, FPM (50-319447-00) NA5018  35x47x5.6mm, FPM NA5017  98x110x8.5mm, FPM (50-319354-00)		
HBS303  [22-47007B] M12x1.75x162mm (x12) →Eng.131034 HBS185  [22-53012B] M12x1.75x157mm (x12) Eng.131035→	JA5037  (31-028599-00) JA5042  (x5) (31-028656-00)			HR5030 	NA5138  44.5x57.2x6.75mm, FPM (50-319352-00) NA5149  [235] 30x54x15mm, FPM (50-319447-00) NA5018  35x47x5.6mm, FPM NA5017  98x110x8.5mm, FPM (50-319354-00)		
HBS185  [22-53012B] M12x1.75x157mm (x12)							
HBS185  [22-53012B] M12x1.75x157mm (x12)	JD5288  (31-029809-00) JA5040  (x5) (31-028657-00) HA5041   [24-28657-00/0]			HR5076  (x2) [24-31947-90/0]	NA5178  45x65x7mm, FPM/ACM (50-319480-00) NA5179  51x65x7mm, FPM (50-319481-00) NA5136  30x47x7mm, NBR (50-319470-00) NA5018  35x47x5.6mm, FPM NA5017  98x110x8.5mm, FPM (50-319354-00)		



KW/PS



V70 2.5L T AWD				09/02 →		200	AE5140 (Fibre)		EE5250
B 5254 T2	2521	5	83.00	Injection, DOHC	154/210	(30-029819-00)		(22-29846-00/0)	
V70 2.5L Turbo AWD				01/97 → 05/00		201	BY360 (Fibre)		EE5250
B 5244 T	2435	5	83.00	MPi, DOHC	142/193	(30-027344-20)	DY362	(22-29846-00/0)	
B 5254 T	2435	5	83.00	MPi, DOHC	142/ 154/ 193/ 210	B 5254 T	(21-27344-21/0)		
V70 2.5L R Sport Mk II				12/02 →		202			EE5250
B 5254 T4	2521	5	83.00	Injection, DOHC	220/300			(22-29846-00/0)	
V90 2.9L				01/97 → 12/98		203	AY260 (Fibre)		EY370
B 6304 S2	2922	6	83.00	Injection, DOHC	132/ 135/ 150/ 180/ 184/ 204	(30-028579-00)	CY260	(22-27343-00/0)	
B 6304 G	2922	6	83.00	Injection, DOHC	150/204		(21-28579-20/0)		
XC70 2.4L D5 XC AWD Diesel				09/02 →		204	AE5260 (MLS), 1.02mm, 1 Hole		
D 5244 T	2401	5	81.00	Common Rail	120/163	(30-029847-00)	AE5270 (MLS), 1.07mm, 2 Holes		
						(30-029848-00)	AE5280 (MLS), 1.12mm, 3 Holes		
						(30-029849-00)	AE5290 (MLS), 1.17mm, 4 Holes		
						(30-029850-00)	AE5300 (MLS), 1.27mm, 5 Holes		
						(30-029851-00)			
XC70 2.4L T XC AWD				03/00 → 09/02		205	AB5450 (Fibre)		EE5250
B 5244 T3	2435	5	83.00		147/200	(30-028683-00)	Eng.1817653 →	(22-29846-00/0)	

								
HBS185  (22-53012B) M12x1.75x157mm (x12)	JD5288  (31-029809-00) JA5040  (x5) (31-028657-00) HA5041   (24-28657-00/0)			HR5076  (x2) (24-31947-90/0)	NA5178  45x65x7mm, FPM/ACM (50-319480-00) NA5179  51x65x7mm, FPM (50-319481-00) NA5136  30x47x7mm, NBR (50-319470-00) NA5018  35x47x5.6mm, FPM NA5017  98x110x8.5mm, FPM (50-319354-00)			 AB5450  AE5140  AE5270  AE5300  AY260  BY360  JA5038  JA5040  JA5044
HBS303  (22-47007B) M12x1.75x162mm (x12) →Eng.131034 HBS185  (22-53012B) M12x1.75x157mm (x12) Eng.131035 →	JA5038  (31-028597-00) JD5288   (31-029809-00) JA5040  (x5) (31-028657-00)			HR5030  (x2) (24-30676-76/0) →Eng.1817652 HR5076  (x2) (24-31947-90/0) Eng.1817653 →	NA5138  44.5x57.2x6.75mm, FPM (50-319352-00) NA5136  30x47x7mm, NBR (50-319470-00) NA5018  35x47x5.6mm, FPM NA5017  98x110x8.5mm, FPM (50-319354-00)			
				HR5076  (x2) (24-31947-90/0)	NA5178  45x65x7mm, FPM/ACM (50-319480-00) NA5179  51x65x7mm, FPM (50-319481-00) NA5136  30x47x7mm, NBR (50-319470-00) NA5018  35x47x5.6mm, FPM NA5017  98x110x8.5mm, FPM (50-319354-00)			
HBS426  (22-47009B) M12x1.75x162mm (x14)	JA5044  (31-028598-00) JA5040  (x6) (31-028657-00) HA5042   (24-28657-01/0)			HR5030  (x2) (24-30676-76/0) →Eng.1818168 HR5076  (x2) (24-31947-90/0) Eng.1818169 →	NA5138  44.5x57.2x6.75mm, FPM (50-319352-00) NA5136  30x47x7mm, NBR (50-319470-00) NA5018  35x47x5.6mm, FPM NA5017  98x110x8.5mm, FPM (50-319354-00)			
					NA5018  35x47x5.6mm, FPM NA5017  98x110x8.5mm, FPM (50-319354-00)			
HBS185  (22-53012B) M12x1.75x157mm (x12)	JD5288  (31-029809-00) JA5040  (x5) (31-028657-00) HA5041   (24-28657-00/0)			HR5030  (x2) (24-30676-76/0) →Eng.1817652 HR5076  (x2) (24-31947-90/0) Eng.1817653 →	NA5178  45x65x7mm, FPM/ACM (50-319480-00) NA5179  51x65x7mm, FPM (50-319481-00) NA5136  30x47x7mm, NBR (50-319470-00) NA5018  35x47x5.6mm, FPM NA5017  98x110x8.5mm, FPM (50-319354-00)			



KW/PS

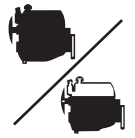

XC70 2.5L T XC AWD				09/02 →	206	AE5140 (Fibre) (30-029819-00)	EE5250 (22-29846-00/0)
B 5254 T2	2521	5	83.00	Injection, DOHC	154/210		
XC90 2.4L D5 Diesel				10/02 →	207	AE5260 (MLS), 1.02mm, 1 Hole (30-029847-00) AE5270 (MLS), 1.07mm, 2 Holes (30-029848-00) AE5280 (MLS), 1.12mm, 3 Holes (30-029849-00) AE5290 (MLS), 1.17mm, 4 Holes (30-029850-00) AE5300 (MLS), 1.27mm, 5 Holes (30-029851-00)	
D 5244 T	2401	5	81.00	Common Rail	120/163		
XC90 2.5L T				10/02 →	208	AE5140 (Fibre) (30-029819-00) →Eng.2979610 AE5560 (MLS) (30-029110-00) Eng.2979611→	EE5250 (22-29846-00/0)
B 5254 T2	2521	5	83.00	Injection, DOHC	154/210		
XC90 2.9L T6				10/02 →	209	AE5150 (Fibre), 1.46mm (30-029820-00) 03/03→	CE5150 (21-29820-20/0) EE5150
B 6294 T	2922	6	83.00	Injection, DOHC, V6	200/272		

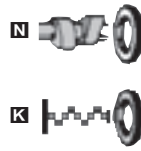
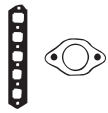

AE5140



AE5150



AE5270



AE5300











AE5560



















JA5040



















JD5297

		CC			9			CC			9
1C	Diesel	1588	4	76.50	109	ACL	Diesel	2384	6	76.50	135
1E	Petrol	2383	6	79.50	132	ACM	Petrol	1043	4	75.00	212
1F	Petrol	1595	4	81.00	162	ACT	Diesel	2384	6	76.50	134
1F	Petrol	1595	4	81.00	23	ACU	Petrol	2461	5	81.00	293
1F	Petrol	1595	4	81.00	237	ACV	Diesel	2461	5	81.00	295
1G	Diesel	2383	6	76.50	136	ADD	Petrol	1781	4	81.00	242
1H	Petrol	1781	4	81.00	76	ADP	Petrol	1595	4	81.00	166
1P	Petrol	1781	4	81.00	121	ADR	Petrol	1781	4	81.00	171
1P	Petrol	1781	4	81.00	73	ADX	Petrol	1296	4	76.50	222
1S	Diesel	2383	6	76.50	134	ADY	Petrol	1984	4	82.50	193
1V	Diesel	1588	4	76.50	120	ADY	Petrol	1984	4	82.50	265
1V	Diesel	1588	4	76.50	67	ADY	Petrol	1984	4	82.50	311
1W	Diesel	1398	4	75.00	229	ADY	Petrol	1984	4	82.50	38
1X	Diesel	1896	4	79.50	284	ADY	Petrol	1984	4	82.50	96
1Y	Diesel	1896	4	79.50	181	ADZ	Petrol	1781	4	81.00	177
1Y	Diesel	1896	4	79.50	250	ADZ	Petrol	1781	4	81.00	244
1Y	Diesel	1896	4	79.50	28	ADZ	Petrol	1781	4	81.00	305
1Y	Diesel	1896	4	79.50	306	ADZ	Petrol	1781	4	81.00	71
1Y	Diesel	1896	4	79.50	80	ADZ	Petrol	1781	4	81.00	72
1Z	Diesel	1896	4	79.50	185	ADZ	Petrol	1781	4	81.00	79
1Z	Diesel	1896	4	79.50	263	AEA	Petrol	1598	4	76.50	238
1Z	Diesel	1896	4	79.50	309	AEA	Petrol	1598	4	76.50	302
1Z	Diesel	1896	4	79.50	31	AEA	Petrol	1598	4	76.50	60
1Z	Diesel	1896	4	79.50	84	AEB	Petrol	1781	4	81.00	171
22R	Petrol	2366	4	92.00	269	AEE	Petrol	1598	4	76.50	21
2E	Petrol	1984	4	82.50	193	AEE	Petrol	1598	4	76.50	232
2E	Petrol	1984	4	82.50	311	AEE	Petrol	1598	4	76.50	238
2E	Petrol	1984	4	82.50	38	AEE	Petrol	1598	4	76.50	302
2E	Petrol	1984	4	82.50	96	AEE	Petrol	1598	4	76.50	60
2G	Petrol	1272	4	75.00	113	AEF	Diesel	1896	4	79.50	245
2G	Petrol	1272	4	75.00	219	AEF	Diesel	1896	4	79.50	27
2G	Petrol	1272	4	75.00	50	AEG	Petrol	1984	4	82.50	157
2H	Petrol	1781	4	81.00	78	AEH	Petrol	1595	4	81.00	2
3F	Petrol	1272	4	75.00	219	AEH	Petrol	1595	4	81.00	233
9A	Petrol	1984	4	82.50	194	AEH	Petrol	1595	4	81.00	56
9A	Petrol	1984	4	82.50	39	AEK	Petrol	1595	4	81.00	165
AAA	Petrol	2792	6	81.00	106	AEK	Petrol	1595	4	81.00	303
AAA	Petrol	2792	6	81.00	207	AEK	Petrol	1595	4	81.00	62
AAA	Petrol	2792	6	81.00	268	AEN	Petrol	2461	5	81.00	293
AAA	Petrol	2792	6	81.00	312	AEP	Petrol	1984	4	82.50	189
AAB	Diesel	2370	5	79.50	292	AER	Petrol	999	4	67.10	138
AAC	Petrol	1968	4	81.00	289	AER	Petrol	999	4	67.10	215
AAF	Petrol	2461	5	81.00	293	AES	Petrol	2792	6	81.00	299
AAK	Petrol	1043	4	75.00	212	AET	Petrol	2461	5	81.00	294
AAM	Petrol	1781	4	81.00	176	AEU	Petrol	2461	5	81.00	293
AAM	Petrol	1781	4	81.00	304	AEV	Petrol	1043	4	75.00	214
AAM	Petrol	1781	4	81.00	70	AEX	Petrol	1390	4	76.50	20
AAU	Petrol	1043	4	75.00	212	AEX	Petrol	1390	4	76.50	226
AAV	Petrol	1272	4	75.00	219	AEX	Petrol	1390	4	76.50	228
AAZ	Diesel	1896	4	79.50	182	AEX	Petrol	1390	4	76.50	301
AAZ	Diesel	1896	4	79.50	308	AEX	Petrol	1390	4	76.50	52
AAZ	Diesel	1896	4	79.50	83	AEY	Diesel	1896	4	79.50	249
ABD	Petrol	1390	4	75.00	301	AEY	Diesel	1896	4	79.50	250
ABD	Petrol	1390	4	75.00	52	AEY	Diesel	1896	4	79.50	29
ABF	Petrol	1984	4	82.50	100	AEY	Diesel	1896	4	79.50	307
ABF	Petrol	1984	4	82.50	195	AEY	Diesel	1896	4	79.50	82
ABL	Diesel	1896	4	79.50	285	AFB	Diesel	2496	6	78.30	205
ABN	Petrol	1595	4	81.00	115	AFH	Petrol	1390	4	76.50	227
ABN	Petrol	1595	4	81.00	59	AFK	Petrol	1390	4	76.50	141
ABS	Petrol	1781	4	81.00	177	AFK	Petrol	1390	4	76.50	225
ABS	Petrol	1781	4	81.00	305	AFN	Diesel	1896	4	79.50	188
ABS	Petrol	1781	4	81.00	71	AFN	Diesel	1896	4	79.50	251
ABS	Petrol	1781	4	81.00	72	AFN	Diesel	1896	4	79.50	264
ABU	Petrol	1598	4	76.50	302	AFN	Diesel	1896	4	79.50	310
ABU	Petrol	1598	4	76.50	60	AFN	Diesel	1896	4	79.50	91
ABV	Petrol	2861	6	82.00	107	AFN	Diesel	1896	4	79.50	92
ABV	Petrol	2861	6	82.00	208	AFT	Petrol	1595	4	81.00	165
ABV	Petrol	2861	6	82.00	40	AFT	Petrol	1595	4	81.00	233
ACC	Petrol	1781	4	81.00	71	AFT	Petrol	1595	4	81.00	303

		CC			9			CC			9
AFT	Petrol	1595	4	81.00	62	ALE	Diesel	1896	4	79.50	253
AFT	Petrol	1595	4	81.00	68	ALE	Diesel	1896	4	79.50	309
AFY	Petrol	1781	4	81.00	171	ALE	Diesel	1896	4	79.50	31
AGD	Diesel	1896	4	79.50	247	ALE	Diesel	1896	4	79.50	84
AGG	Petrol	1984	4	82.50	193	ALH	Diesel	1896	4	79.50	156
AGG	Petrol	1984	4	82.50	311	ALH	Diesel	1896	4	79.50	253
AGG	Petrol	1984	4	82.50	96	ALH	Diesel	1896	4	79.50	31
AGL	Petrol	2295	4	90.90	128	ALH	Diesel	1896	4	79.50	85
AGN	Petrol	1781	4	81.00	6	ALH	Diesel	1896	4	79.50	9
AGN	Petrol	1781	4	81.00	74	ALL	Petrol	999	4	67.10	138
AGP	Diesel	1896	4	79.50	246	ALL	Petrol	999	4	67.10	215
AGP	Diesel	1896	4	79.50	8	ALM	Petrol	1598	4	76.50	232
AGP	Diesel	1896	4	79.50	81	ALT	Petrol	1984	4	82.50	191
AGR	Diesel	1896	4	79.50	253	ALZ	Petrol	1595	4	81.00	159
AGR	Diesel	1896	4	79.50	85	AMF	Diesel	1422	3	79.50	143
AGR	Diesel	1896	4	79.50	9	AMF	Diesel	1422	3	79.50	231
AGU	Petrol	1781	4	81.00	154	AMV	Petrol	2792	6	81.00	298
AGU	Petrol	1781	4	81.00	7	AMY	Petrol	2792	6	81.00	268
AGU	Petrol	1781	4	81.00	77	ANA	Petrol	1595	4	81.00	166
AGX	Diesel	2459	5	81.00	129	ANB	Petrol	1781	4	81.00	171
AGZ	Petrol	2324	5	81.00	102	ANJ	Diesel	2461	5	81.00	130
AGZ	Petrol	2324	5	81.00	15	ANM	Petrol	1390	4	76.50	141
AGZ	Petrol	2324	5	81.00	204	ANP	Petrol	1781	4	81.00	72
AHB	Diesel	1716	4	79.50	25	ANP	Petrol	1781	4	81.00	79
AHD	Diesel	2459	5	81.00	131	ANU	Diesel	1896	4	79.50	263
AHF	Diesel	1896	4	79.50	10	ANV	Petrol	999	4	67.10	138
AHF	Diesel	1896	4	79.50	86	ANW	Petrol	1390	4	76.50	226
AHG	Diesel	1716	4	79.50	240	ANY	Diesel	1191	3	76.50	139
AHH	Diesel	1896	4	79.50	187	APA	Diesel	2461	5	81.00	130
AHL	Petrol	1595	4	81.00	166	APE	Petrol	1390	4	76.50	1
AHS	Petrol	1598	4	76.50	238	APE	Petrol	1390	4	76.50	141
AHT	Petrol	999	4	67.10	138	APE	Petrol	1390	4	76.50	225
AHU	Diesel	1896	4	79.50	187	APE	Petrol	1390	4	76.50	53
AHU	Diesel	1896	4	79.50	253	APF	Petrol	1595	4	81.00	2
AHU	Diesel	1896	4	79.50	263	APF	Petrol	1595	4	81.00	233
AHU	Diesel	1896	4	79.50	309	APF	Petrol	1595	4	81.00	56
AHU	Diesel	1896	4	79.50	31	APH	Petrol	1781	4	81.00	154
AHU	Diesel	1896	4	79.50	84	APK	Petrol	1984	4	82.50	14
AHW	Petrol	1390	4	76.50	1	APK	Petrol	1984	4	82.50	157
AHW	Petrol	1390	4	76.50	141	APK	Petrol	1984	4	82.50	95
AHW	Petrol	1390	4	76.50	225	APL	Petrol	2461	5	81.00	294
AHW	Petrol	1390	4	76.50	53	APQ	Petrol	1390	4	76.50	20
AHY	Diesel	2461	5	81.00	296	APQ	Petrol	1390	4	76.50	226
AJA	Diesel	2370	5	79.50	291	APQ	Petrol	1390	4	76.50	52
AJH	Petrol	1781	4	81.00	260	APT	Petrol	1781	4	81.00	171
AJM	Diesel	1896	4	79.50	11	APU	Petrol	1781	4	81.00	171
AJM	Diesel	1896	4	79.50	183	AQM	Diesel	1896	4	79.50	246
AJM	Diesel	1896	4	79.50	87	AQM	Diesel	1896	4	79.50	8
AJT	Diesel	2461	5	81.00	295	AQM	Diesel	1896	4	79.50	81
AJV	Petrol	1598	4	76.50	236	AQN	Petrol	2324	5	81.00	103
AKK	Petrol	1390	4	76.50	226	AQN	Petrol	2324	5	81.00	158
AKL	Petrol	1595	4	81.00	2	AQN	Petrol	2324	5	81.00	16
AKL	Petrol	1595	4	81.00	233	AQP	Petrol	2792	6	81.00	105
AKL	Petrol	1595	4	81.00	56	AQP	Petrol	2792	6	81.00	17
AKN	Diesel	2496	6	78.30	205	AQQ	Petrol	1390	4	76.50	141
AKQ	Petrol	1390	4	76.50	1	AQQ	Petrol	1390	4	76.50	225
AKQ	Petrol	1390	4	76.50	141	AQY	Petrol	1984	4	82.50	14
AKQ	Petrol	1390	4	76.50	53	AQY	Petrol	1984	4	82.50	157
AKR	Petrol	1984	4	82.50	311	AQY	Petrol	1984	4	82.50	95
AKR	Petrol	1984	4	82.50	96	ARC	Petrol	1598	4	76.50	235
AKS	Petrol	1595	4	81.00	62	ARG	Petrol	1781	4	81.00	171
AKS	Petrol	1595	4	81.00	68	ARL	Diesel	1896	4	79.50	13
AKU	Diesel	1716	4	79.50	145	ARL	Diesel	1896	4	79.50	88
AKU	Diesel	1716	4	79.50	239	ARM	Petrol	1595	4	81.00	166
AKV	Petrol	1390	4	76.50	20	ARR	Petrol	1390	4	76.50	142
AKV	Petrol	1390	4	76.50	226	ARX	Petrol	1781	4	81.00	7
AKW	Diesel	1716	4	79.50	241	ARZ	Petrol	1781	4	81.00	77
ALD	Petrol	999	4	67.10	138	ASV	Diesel	1896	4	79.50	10
ALD	Petrol	999	4	67.10	211	ASV	Diesel	1896	4	79.50	251

		CC			9			CC			9
ASV	Diesel	1896	4	79.50	86	AXG	Diesel	2461	5	81.00	296
ASX	Diesel	1896	4	79.50	247	AXL	Diesel	2461	5	81.00	295
ASY	Diesel	1896	4	79.50	248	AXP	Petrol	1390	4	76.50	1
ASZ	Diesel	1896	4	79.50	12	AXP	Petrol	1390	4	76.50	53
ASZ	Diesel	1896	4	79.50	252	AXR	Diesel	1896	4	79.50	12
ASZ	Diesel	1896	4	79.50	261	AXR	Diesel	1896	4	79.50	155
ASZ	Diesel	1896	4	79.50	87	AXR	Diesel	1896	4	79.50	252
ATD	Diesel	1896	4	79.50	12	AXR	Diesel	1896	4	79.50	87
ATD	Diesel	1896	4	79.50	155	AXU	Petrol	1390	4	76.50	230
ATD	Diesel	1896	4	79.50	252	AXW	Petrol	1984	4	82.50	275
ATD	Diesel	1896	4	79.50	87	AXW	Petrol	1984	4	82.50	98
ATJ	Diesel	1896	4	79.50	183	AYC	Diesel	2461	5	81.00	295
ATM	Petrol	1984	4	82.50	265	AYD	Petrol	1595	4	81.00	153
ATN	Petrol	1598	4	81.00	4	AYL	Petrol	2792	6	81.00	267
ATN	Petrol	1598	4	81.00	63	AYQ	Diesel	1896	4	79.50	29
AUA	Petrol	1390	4	76.50	141	AYT	Petrol	3189	6	84.00	210
AUA	Petrol	1390	4	76.50	18	AYY	Diesel	2461	5	81.00	295
AUA	Petrol	1390	4	76.50	225	AYZ	Diesel	1191	3	76.50	139
AUB	Petrol	1390	4	76.50	141	AZD	Petrol	1598	4	76.50	4
AUB	Petrol	1390	4	76.50	225	AZD	Petrol	1598	4	76.50	63
AUC	Petrol	999	4	67.10	138	AZG	Petrol	1984	4	82.50	14
AUC	Petrol	999	4	67.10	211	AZG	Petrol	1984	4	82.50	157
AUD	Petrol	1390	4	76.50	140	AZG	Petrol	1984	4	82.50	95
AUD	Petrol	1390	4	76.50	20	AZH	Petrol	1984	4	82.50	14
AUD	Petrol	1390	4	76.50	226	AZH	Petrol	1984	4	82.50	95
AUE	Petrol	2792	6	81.00	105	AZJ	Petrol	1984	4	82.50	14
AUE	Petrol	2792	6	81.00	17	AZJ	Petrol	1984	4	82.50	157
AUF	Diesel	2461	5	81.00	295	AZJ	Petrol	1984	4	82.50	95
AUM	Petrol	1781	4	81.00	7	AZM	Petrol	1984	4	82.50	190
AUM	Petrol	1781	4	81.00	77	AZQ	Petrol	1198	3	76.50	217
AUQ	Petrol	1781	4	81.00	7	AZV	Diesel	1968	4	81.00	126
AUQ	Petrol	1781	4	81.00	77	AZV	Diesel	1968	4	81.00	276
AUR	Petrol	1595	4	81.00	233	AZV	Diesel	1968	4	81.00	94
AUS	Petrol	1598	4	76.50	4	AZX	Petrol	2324	5	81.00	203
AUS	Petrol	1598	4	76.50	63	AZZ	Petrol	3189	6	84.00	271
AUY	Diesel	1896	4	79.50	11	BAA	Petrol	3189	6	84.00	271
AUY	Diesel	1896	4	79.50	261	BAD	Petrol	1598	4	76.50	5
AUY	Diesel	1896	4	79.50	87	BAD	Petrol	1598	4	76.50	65
AVB	Diesel	1896	4	79.50	184	BAG	Petrol	1598	4	76.50	273
AVC	Petrol	1781	4	81.00	154	BAG	Petrol	1598	4	76.50	55
AVF	Diesel	1896	4	79.50	184	BAU	Diesel	2496	6	78.30	206
AVG	Diesel	1896	4	79.50	188	BAY	Diesel	1422	3	79.50	231
AVG	Diesel	1896	4	79.50	264	BBE	Diesel	2461	5	81.00	130
AVG	Diesel	1896	4	79.50	92	BBF	Diesel	2461	5	81.00	130
AVH	Petrol	1984	4	82.50	157	BBY	Petrol	1390	4	76.50	141
AVQ	Diesel	1896	4	79.50	274	BBY	Petrol	1390	4	76.50	225
AVR	Diesel	2461	5	81.00	130	BBZ	Petrol	1390	4	76.50	225
AVT	Petrol	2461	5	81.00	294	BCA	Petrol	1390	4	76.50	1
AVU	Petrol	1595	4	81.00	3	BCA	Petrol	1390	4	76.50	151
AVU	Petrol	1595	4	81.00	57	BCA	Petrol	1390	4	76.50	19
AVY	Petrol	1598	4	76.50	144	BCA	Petrol	1390	4	76.50	53
AVY	Petrol	1598	4	76.50	235	BCB	Petrol	1598	4	76.50	4
AWC	Petrol	1781	4	81.00	260	BCB	Petrol	1598	4	76.50	63
AWH	Petrol	1595	4	81.00	152	BDE	Petrol	2792	6	81.00	105
AWL	Petrol	1781	4	81.00	180	BDE	Petrol	2792	6	81.00	17
AWM	Petrol	1781	4	81.00	180	BDF	Petrol	2792	6	81.00	104
AWT	Petrol	1781	4	81.00	180	BDG	Diesel	2496	6	78.30	206
AWU	Petrol	1781	4	81.00	154	BDH	Diesel	2496	6	78.30	206
AWV	Petrol	1781	4	81.00	154	BDJ	Diesel	1968	4	81.00	35
AWX	Diesel	1986	4	79.50	184	BDK	Diesel	1968	4	81.00	101
AWY	Petrol	1198	3	76.50	218	BDL	Petrol	3189	6	84.00	150
AXA	Petrol	1984	4	82.50	148	BDL	Petrol	3189	6	84.00	300
AXA	Petrol	1984	4	82.50	288	BEH	Bi-Fuel	1984	4	82.50	97
AXB	Diesel	1896	4	79.50	146	BEJ	Petrol	1984	4	82.50	157
AXB	Diesel	1896	4	79.50	286	BER	Petrol	1984	4	82.50	157
AXC	Diesel	1896	4	79.50	286	BEV	Petrol	1984	4	82.50	157
AXD	Diesel	2461	5	81.00	149	BEW	Diesel	1896	4	79.50	155
AXE	Diesel	2461	5	81.00	149	BFH	Petrol	3189	6	84.00	108
AXE	Diesel	2461	5	81.00	297	BFQ	Petrol	1595	4	81.00	3

		CC			9			CC			9
BFQ	Petrol	1595	4	81.00	57	BMR	Diesel	1968	4	81.00	199
BFS	Petrol	1595	4	81.00	153	BMS	Diesel	1422	3	79.50	231
BGH	Diesel	1968	4	81.00	198	BMT	Diesel	1896	4	79.50	252
BGU	Petrol	1595	4	81.00	22	BMX	Petrol	3189	6	84.00	271
BGU	Petrol	1595	4	81.00	272	BNM	Diesel	1422	3	79.50	231
BGU	Petrol	1595	4	81.00	61	BNM	Diesel	1422	3	79.50	46
BGW	Diesel	1968	4	81.00	198	BNV	Diesel	1422	3	79.50	231
BHP	Petrol	1984	4	82.50	157	BNZ	Diesel	2460	5	81.00	149
BHW	Diesel	1968	4	81.00	198	BPC	Diesel	2461	5	81.00	149
BJB	Diesel	1896	4	79.50	30	BPC	Diesel	2461	5	81.00	297
BJH	Petrol	1595	4	81.00	3	BRK	Petrol	3189	6	84.00	210
BJH	Petrol	1595	4	81.00	57	BRS	Diesel	1896	4	79.50	147
BJX	Petrol	1781	4	81.00	243	BRS	Diesel	1896	4	79.50	287
BKC	Diesel	1896	4	79.50	123	BRT	Diesel	1968	4	81.00	266
BKC	Diesel	1896	4	79.50	186	BRU	Diesel	1896	4	79.50	274
BKC	Diesel	1896	4	79.50	274	BRU	Diesel	1896	4	79.50	90
BKC	Diesel	1896	4	79.50	89	BSE	Petrol	1595	4	81.00	116
BKD	Diesel	1968	4	81.00	276	BSE	Petrol	1595	4	81.00	164
BKD	Diesel	1968	4	81.00	94	BSE	Petrol	1595	4	81.00	22
BKF	Petrol	1781	4	81.00	154	BSE	Petrol	1595	4	81.00	272
BKG	Petrol	1390	4	76.50	54	BSE	Petrol	1595	4	81.00	61
BKJ	Petrol	3189	6	84.00	271	BSF	Petrol	1595	4	81.00	116
BKK	Petrol	3189	6	84.00	150	BSF	Petrol	1595	4	81.00	164
BKK	Petrol	3189	6	84.00	300	BSF	Petrol	1595	4	81.00	22
BKL	Petrol	3189	6	84.00	210	BSF	Petrol	1595	4	81.00	272
BKP	Diesel	1968	4	81.00	200	BSF	Petrol	1595	4	81.00	61
BKS	Diesel	2967	6	83.00	270	BST	Diesel	1968	4	81.00	35
BKY	Petrol	1390	4	76.50	225	BSU	Diesel	1896	4	79.50	32
BLF	Petrol	1598	4	76.50	118	BSW	Diesel	1896	4	79.50	155
BLF	Petrol	1598	4	76.50	168	BSX	Petrol	1984	4	82.50	34
BLF	Petrol	1598	4	76.50	273	BTB	Diesel	1896	4	79.50	262
BLF	Petrol	1598	4	76.50	41	BTS	Petrol	1598	4	76.50	234
BLF	Petrol	1598	4	76.50	55	BUB	Petrol	3189	6	84.00	108
BLN	Petrol	1390	4	76.50	54	BUB	Petrol	3189	6	84.00	44
BLP	Petrol	1598	4	76.50	273	BUD	Petrol	1390	4	76.50	18
BLP	Petrol	1598	4	76.50	55	BUD	Petrol	1390	4	76.50	225
BLR	Petrol	1984	4	82.50	125	BUD	Petrol	1390	4	76.50	53
BLR	Petrol	1984	4	82.50	196	BVD	Diesel	1968	4	81.00	200
BLR	Petrol	1984	4	82.50	197	BVE	Diesel	1968	4	81.00	200
BLR	Petrol	1984	4	82.50	275	BVK	Diesel	1896	4	79.50	261
BLR	Petrol	1984	4	82.50	98	BVX	Petrol	1984	4	82.50	197
BLS	Diesel	1896	4	79.50	123	BVX	Petrol	1984	4	82.50	98
BLS	Diesel	1896	4	79.50	186	BVY	Petrol	1984	4	82.50	125
BLS	Diesel	1896	4	79.50	30	BVY	Petrol	1984	4	82.50	196
BLS	Diesel	1896	4	79.50	89	BVY	Petrol	1984	4	82.50	197
BLT	Diesel	1896	4	79.50	252	BVY	Petrol	1984	4	82.50	42
BLX	Petrol	1984	4	82.50	197	BVY	Petrol	1984	4	82.50	98
BLX	Petrol	1984	4	82.50	275	BVZ	Petrol	1984	4	82.50	125
BLX	Petrol	1984	4	82.50	98	BVZ	Petrol	1984	4	82.50	196
BLY	Petrol	1984	4	82.50	125	BVZ	Petrol	1984	4	82.50	197
BLY	Petrol	1984	4	82.50	196	BVZ	Petrol	1984	4	82.50	42
BLY	Petrol	1984	4	82.50	197	BVZ	Petrol	1984	4	82.50	98
BLY	Petrol	1984	4	82.50	275	BWB	Diesel	1422	3	79.50	231
BLY	Petrol	1984	4	82.50	98	BXE	Diesel	1896	4	79.50	123
BMA	Diesel	1968	4	81.00	200	BXE	Diesel	1896	4	79.50	186
BMD	Petrol	1198	3	76.50	218	BXE	Diesel	1896	4	79.50	274
BMD	Petrol	1198	3	76.50	45	BXE	Diesel	1896	4	79.50	89
BME	Petrol	1198	3	76.50	217	BXF	Diesel	1896	4	79.50	90
BMK	Diesel	2967	6	83.00	209	BXJ	Diesel	1896	4	79.50	274
BML	Petrol	3189	6	84.00	108	BXJ	Diesel	1896	4	79.50	90
BMM	Diesel	1968	4	81.00	124	BZG	Petrol	1198	3	76.50	217
BMM	Diesel	1968	4	81.00	278	CBAA	Diesel	1968	4	81.00	200
BMM	Diesel	1968	4	81.00	33	CBAB	Diesel	1968	4	81.00	200
BMM	Diesel	1968	4	81.00	43	CBDA	Diesel	1968	4	81.00	94
BMM	Diesel	1968	4	81.00	93	CBDB	Diesel	1968	4	81.00	94
BMN	Diesel	1968	4	81.00	127	CBPA	Petrol	1984	4	82.50	157
BMN	Diesel	1968	4	81.00	277	CBRA	Petrol	3189	6	84.00	44
BMN	Diesel	1968	4	81.00	99	CCSA	Petrol	1595	4	81.00	116
BMP	Diesel	1968	4	81.00	201	CFLA	Petrol	3189	6	84.00	150

		CC			9			CC			9
CFLA	Petrol	3189	6	84.00	300	JR	Diesel	1588	4	76.50	119
CGGA	Petrol	1390	4	76.50	53	JR	Diesel	1588	4	76.50	66
CP	Diesel	2383	6	76.50	133	JS	Petrol	1994	5	81.00	192
CR	Diesel	1588	4	76.50	167	JT	Petrol	2226	5	81.00	202
CS	Diesel	1588	4	76.50	279	JV	Petrol	1781	4	81.00	173
CY	Diesel	1588	4	76.50	169	JX	Diesel	1588	4	76.50	280
DF	Petrol	1915	4	94.00	283	KR	Petrol	1781	4	81.00	122
DG	Petrol	1915	4	94.00	283	KR	Petrol	1781	4	81.00	178
DH	Petrol	1913	4	94.00	283	KR	Petrol	1781	4	81.00	259
DJ	Petrol	2109	4	94.00	290	KR	Petrol	1781	4	81.00	36
DL	Petrol	2383	6	76.50	132	KR	Petrol	1781	4	81.00	75
DS	Petrol	1781	4	81.00	173	KV	Petrol	2226	5	81.00	202
DS	Petrol	1781	4	81.00	254	KX	Petrol	2226	5	81.00	202
DT	Petrol	1595	4	81.00	163	KY	Diesel	1716	4	79.50	281
DV	Diesel	2383	6	76.50	136	ME	Diesel	1588	4	76.50	117
DW	Diesel	2383	6	76.50	133	ME	Diesel	1588	4	76.50	24
DW	Diesel	2383	6	76.50	137	ME	Diesel	1588	4	76.50	64
DX	Petrol	1781	4	81.00	258	MF	Diesel	1588	4	76.50	119
DX	Petrol	1781	4	81.00	73	MF	Diesel	1588	4	76.50	66
DZ	Petrol	1781	4	81.00	174	MH	Petrol	1272	4	75.00	112
EV	Petrol	1781	4	81.00	121	MH	Petrol	1272	4	75.00	113
EV	Petrol	1781	4	81.00	258	MH	Petrol	1272	4	75.00	219
EV	Petrol	1781	4	81.00	73	MH	Petrol	1272	4	75.00	221
EW	Petrol	1595	4	81.00	23	MH	Petrol	1272	4	75.00	49
EW	Petrol	1595	4	81.00	256	MH	Petrol	1272	4	75.00	50
EW	Petrol	1595	4	81.00	58	MN	Diesel	1272	4	75.00	223
EWA	Petrol	1595	4	81.00	256	MV	Petrol	2109	4	94.00	290
EX	Petrol	1781	4	81.00	257	NU	Petrol	1272	4	75.00	51
EX	Petrol	1781	4	81.00	73	NZ	Petrol	1272	4	75.00	113
EZ	Petrol	1595	4	81.00	115	NZ	Petrol	1272	4	75.00	219
EZ	Petrol	1595	4	81.00	162	NZ	Petrol	1272	4	75.00	50
EZ	Petrol	1595	4	81.00	59	PB	Petrol	1781	4	81.00	121
GF	Petrol	1272	4	75.01	48	PB	Petrol	1781	4	81.00	175
GK	Petrol	1272	4	75.00	220	PB	Petrol	1781	4	81.00	258
GS	Petrol	1272	4	75.00	48	PB	Petrol	1781	4	81.00	73
GT	Petrol	1272	4	75.00	111	PD	Petrol	1781	4	81.00	282
GT	Petrol	1272	4	75.00	48	PF	Petrol	1781	4	81.00	121
GU	Petrol	1781	4	81.00	121	PF	Petrol	1781	4	81.00	175
GU	Petrol	1781	4	81.00	73	PF	Petrol	1781	4	81.00	73
GW	Petrol	1913	4	94.00	283	PG	Petrol	1781	4	81.00	179
GX	Petrol	1781	4	81.00	121	PG	Petrol	1781	4	81.00	37
GX	Petrol	1781	4	81.00	73	PG	Petrol	1781	4	81.00	76
GZ	Petrol	1781	4	81.00	121	PL	Petrol	1781	4	81.00	122
GZ	Petrol	1781	4	81.00	73	PL	Petrol	1781	4	81.00	259
HB	Petrol	1093	4	69.50	216	PL	Petrol	1781	4	81.00	75
HK	Petrol	1272	4	75.00	112	PN	Petrol	1595	4	81.00	114
HK	Petrol	1272	4	75.00	221	PN	Petrol	1595	4	81.00	58
HK	Petrol	1272	4	75.00	49	PP	Petrol	1595	4	81.00	160
HM	Petrol	1595	4	81.00	115	PY	Petrol	1272	4	75.00	224
HM	Petrol	1595	4	81.00	59	RA	Diesel	1588	4	76.50	120
HN	Petrol	1595	4	81.00	58	RA	Diesel	1588	4	76.50	170
HP	Petrol	1994	5	81.00	192	RA	Diesel	1588	4	76.50	67
HT	Petrol	1781	4	81.00	73	RD	Petrol	1781	4	81.00	121
HV	Petrol	1781	4	81.00	121	RD	Petrol	1781	4	81.00	73
HV	Petrol	1781	4	81.00	73	RE	Petrol	1595	4	81.00	256
HW	Petrol	1272	4	75.00	220	RE	Petrol	1595	4	81.00	58
HZ	Petrol	1043	4	75.00	212	RF	Petrol	1595	4	81.00	114
HZ	Petrol	1043	4	75.00	213	RF	Petrol	1595	4	81.00	58
HZ	Petrol	1043	4	75.00	47	RH	Petrol	1781	4	81.00	121
JH	Petrol	1781	4	81.00	257	RH	Petrol	1781	4	81.00	69
JH	Petrol	1781	4	81.00	26	RL	Petrol	1595	4	81.00	163
JH	Petrol	1781	4	81.00	73	RM	Petrol	1781	4	81.00	172
JJ	Petrol	1781	4	81.00	258	RP	Petrol	1781	4	81.00	121
JJ	Petrol	1781	4	81.00	73	RP	Petrol	1781	4	81.00	177
JK	Diesel	1588	4	76.50	167	RP	Petrol	1781	4	81.00	73
JK	Diesel	1588	4	76.50	24	SB	Diesel	1588	4	76.50	120
JN	Petrol	1781	4	81.00	173	SB	Diesel	1588	4	76.50	170
JP	Diesel	1588	4	76.50	117	SB	Diesel	1588	4	76.50	67
JP	Diesel	1588	4	76.50	64	SR	Petrol	2109	4	94.00	290



CC



9



CC



9











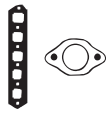

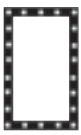

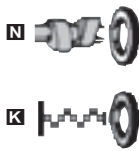





SS	Petrol	2109	4	94.00	290
WL	Petrol	1714	4	79.50	110
WN	Petrol	1921	5	79.50	255
WV	Petrol	1588	4	79.50	161
YN	Petrol	1588	4	79.50	161
YX	Petrol	1714	4	79.50	110



KW/PS



Bora 1.4L 16V					03/00 → 05/05	1	AB5701 (MLS)	CB5700	EB5700 [8]
AHW/AKQ	1390	4	76.50			55/75	30-029313-10	21-29313-20/0	22-29313-00/0
APE	1390	4	76.50	MPI, DOHC		55/75			
AXP	1390	4	76.50	DOHC		55/75			
BCA	1390	4	76.50			55/75			
Bora 1.6L					10/98 → 05/05	2	AC5220 (MLS)	CC5221	EC080 [8]
AEH	1595	4	81.00	Motronic		74/100	30-029462-00	21-29462-21/0	(22-28897-01/0)
AKL	1595	4	81.00			74/100	APF	APF	AEH, AKL
APF	1595	4	81.00	SOHC		74/100	AY980 (MLS)	CY980	EC5220 [8]
							30-028925-00	21-28925-20/0	(22-29462-00/0)
							AEH, AKL	AEH, AKL	APF
Bora 1.6L					08/00 → 05/05	3	AC5220 (MLS)	CC5222	EC5220 [8]
AVU/BFQ	1595	4	81.00	SOHC		75/102	30-029462-00	21-29462-22/0	(22-29462-00/0)
BJH	1595	4	81.00	Injection, SOHC		75/102			
Bora 1.6L 16V					02/00 → 05/05	4	AC5280 (MLS)	CC5280 [41]	EB5700 [8]
AUS/AZD	1598	4	76.50	DOHC		77/105	30-029466-00	21-29466-20/0	22-29313-00/0
BCB	1598	4	76.50			77/105		ATN, AUS	
ATN	1598	4	81.00	SOHC		75/102		CC5281	
								21-29466-21/0	
								AZD, BCB	
Bora 1.6L FSI					01/02 → 05/05	5	AC5280 (MLS)		
BAD	1598	4	76.50			81/110	30-029466-00		
Bora 1.8L 4motion					02/99 → 05/05	6	AY970 (MLS)		EY841
AGN	1781	4	81.00	Injection, DOHC		92/125	30-028495-00		22-28897-02/0
Bora 1.8L T					05/00 → 05/05	7	AY970 (MLS)	CY971	EY841
AGU	1781	4	81.00	Injection, DOHC		110/150	30-028495-00	21-28495-21/0	22-28897-02/0
ARX/AUM	1781	4	81.00	DOHC		110/150			
AUQ	1781	4	81.00	DOHC		132/180			

								
HBS249 ® (22-33025B) M9x1.25x138mm (x10)	JD5228 ■ (x4) (50-029071-00) JD5298 ■ (31-029825-00)	HR397 [57] 34-000410-00	HR397 [57] 34-000410-00	HR791 ■ 24-30614-76/0	NA5180 27x42x8mm, FPM (50-319484-00) NA5185 ■ 32x42x6mm, FPM (50-319489-00) LK5011 ■ [3] [78] 85x131x15.94mm, PTFE	KA5025 [13] KK5551 [81]		 AC5220  AC5280  AY970  AY980  JD5228  JD5293  JD5298  JD5373  JD600  JD604  JD605  JD607  JP024
HBS246 ® (22-33024B) M10x1.50x120mm (x10)	JD5340 ■ (x4) (50-029939-00) APF JD607 ■ 50-028924-00 AEH, AKL JD5293 ■ (31-029816-00) APF JD600 ■ 31-028454-00 AEH, AKL  JF211 (31-028926-00)	JP024 50-027505-00	HR397 [57] 34-000410-00 JH5117 (50-030046-00)	HR816 ■ 24-30653-85/0	NA5124 32x47x10mm, PTFE (50-319433-00) NA5106 ■ 35x48x10mm, PTFE (50-319430-00) LK5008 ■ [3] 85x131x15.7mm, PTFE (50-319472-00)	HL5034 [245] ■		
HBS246 ® (22-33024B) M10x1.50x120mm (x10)	JD5340 ■ (x4) (50-029939-00) JD5293 ■ (31-029816-00)	JM5205 50-029938-00 (Rubber)	HR397 [57] 34-000410-00	HR817 ■ 24-30614-78/0	NA5124 32x47x10mm, PTFE (50-319433-00) NA5106 ■ 35x48x10mm, PTFE (50-319430-00) LK5008 ■ [3] 85x131x15.7mm, PTFE (50-319472-00)	HL5034 [245] ■		
HBS316 ® (22-33036B) M9x1.25x97mm (x10)	JD5228 ■ (x4) (50-029071-00) AZD, BCB JD5373 ■ (31-029966-00) ATN, AUS JD5298 ■ (31-029825-00)	HR397 [57] 34-000410-00	HR397 [57] 34-000410-00	HR791 ■ 24-30614-76/0	NA5180 (x2) 27x42x8mm, FPM (50-319484-00) NA5185 ■ 32x42x6mm, FPM (50-319489-00) LK5011 ■ [3] [78] 85x131x15.94mm, PTFE ATN, AUS	KK5551 [81]		
HBS316 ® (22-33036B) M9x1.25x97mm (x10)	JD5809 ■ 31-030229-00 JD5298 ■ (31-029825-00)	HR397 [57] 34-000410-00	HR397 [57] 34-000410-00	HR791 ■ 24-30614-76/0	NA5180 27x42x8mm, FPM (50-319484-00) NA5185 ■ 32x42x6mm, FPM (50-319489-00)			
HBS268 ® (22-33031B) M10x1.50x120mm (x10)	JD607 ■ 50-028924-00 JD605 ■ 31-028826-00  JF205 (31-025070-00)	HL732 ■ 24-28815-00/0	HR397 [57] 34-000410-00 JH5117 (50-030046-00)	HR822 ■	NA5124 (x2) 32x47x10mm, PTFE (50-319433-00) NA5106 ■ 35x48x10mm, PTFE (50-319430-00) LK5003 ■ [3] 85x131x15.7mm, PTFE (50-319434-00)	HL5034 [245] ■		
HBS268 ® (22-33031B) M10x1.50x120mm (x10)	JD604 ■ (31-028824-00) JD605 ■ 31-028826-00	HL732 ■ 24-28815-00/0	HR397 [57] 34-000410-00 JH5117 (50-030046-00)	HR822 ■	NA5124 32x47x10mm, PTFE (50-319433-00) NA5106 ■ 35x48x10mm, PTFE (50-319430-00) LK5003 ■ [3] 85x131x15.7mm, PTFE (50-319434-00)	HL5034 [245] ■		



KW/PS

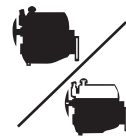

Bora 1.9L SDI Diesel				10/98 → 05/05	8			
AGP	1896	4	79.50	SDi	50/68	BZ010 (MLS), 1.45mm, 1 Hole 30-028910-10 →Eng.AGP 028 000 BZ020 (MLS), 1.53mm, 2 Holes 30-028911-10 →Eng.AGP 028 000 BZ030 (MLS), 1.61mm, 3 Holes 30-028912-10 →Eng.AGP 028 000 BZ040 (MLS), 1.47mm, 1 Hole 30-028915-10 Eng.AGP 028 001 → AQM BZ050 (MLS), 1.57mm, 2 Holes 30-028916-10 Eng.AGP 028 001 → AQM BZ060 (MLS), 1.67mm, 3 Holes 30-028917-10 Eng.AGP 028 001 → AQM	DZ010 ▲☒ 21-26556-20/0 AGP	EC060 [8] 22-28897-00/0
AQM	1896	4	79.50		50/68			
Bora 1.9L TDI Diesel				10/98 → 06/01	9			
AGR	1896	4	79.50	SOHC	66/89	BZ010 (MLS), 1.45mm, 1 Hole 30-028910-10 →Eng.AGR 151 000 →Eng.ALH 085 000 BZ020 (MLS), 1.53mm, 2 Holes 30-028911-10 →Eng.AGR 151 000 →Eng.ALH 085 000 BZ030 (MLS), 1.61mm, 3 Holes 30-028912-10 →Eng.AGR 151 000 →Eng.ALH 085 000 BZ040 (MLS), 1.47mm, 1 Hole 30-028915-10 Eng.AGR 151 001 → Eng.ALH 085 001 → BZ050 (MLS), 1.57mm, 2 Holes 30-028916-10 Eng.AGR 151 001 → Eng.ALH 085 001 → BZ060 (MLS), 1.67mm, 3 Holes 30-028917-10 Eng.AGR 151 001 → Eng.ALH 085 001 →	DZ010 ▲☒ 21-26556-20/0	EC060 [8] 22-28897-00/0
ALH	1896	4	79.50		66/89			

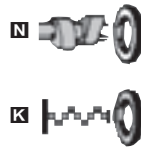
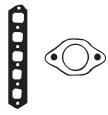

BZ010, BZ020,
BZ030



BZ040, BZ050,
BZ060



JC152



JD170



JD600



JD606

HBS018Ⓞ
(22-39024B)
M12x1.75x115mm (x10)

JD170■
31-026556-10
JC152■ (x4)
31-026555-00
AGP
JD600■
31-028454-00
AQM
 JE5076
(31-028373-00)

HR397 [57]
34-000410-00

HR816■
24-30653-85/0

NA5001 32x47x10mm, FPM
(50-303185-50)
 NA5106■ 35x48x10mm, PTFE
(50-319430-00)
 LK5003■ [3] 85x131x15.7mm, PTFE
(50-319434-00)

NA5278 [54]

HBS018Ⓞ
(22-39024B)
M12x1.75x115mm (x10)

JD170■
31-026556-10
JC152■ (x4)
31-026555-00
JD606■
(31-028918-00)

HR397 [57]
34-000410-00

HR816■
24-30653-85/0

NA5001 32x47x10mm, FPM
(50-303185-50)
 NB716■ 35x48x10mm, FPM
(50-306067-50)
 LK5003■ [3] 85x131x15.7mm, PTFE
(50-319434-00)

NA5278 [54]



KW/PS



Bora 1.9L TDI Diesel				10/98 → 06/01		10	BZ010 (MLS), 1.45mm, 1 Hole 30-028910-10 →Eng.AHF 140 000 BZ020 (MLS), 1.53mm, 2 Holes 30-028911-10 →Eng.AHF 140 000 BZ030 (MLS), 1.61mm, 3 Holes 30-028912-10 →Eng.AHF 140 000 BZ040 (MLS), 1.47mm, 1 Hole 30-028915-10 Eng.AHF 140 001 → ASV BZ050 (MLS), 1.57mm, 2 Holes 30-028916-10 Eng.AHF 140 001 → ASV BZ060 (MLS), 1.67mm, 3 Holes 30-028917-10 Eng.AHF 140 001 → ASV	DZ010 ▲☒ 21-26556-20/0	EC060 [8] 22-28897-00/0
AHF	1896	4	79.50		81/110				
ASV	1896	4	79.50	SOHC	81/110				
Bora 1.9L TDI Diesel				12/98 → 06/01		11	AF5381 (MLS), 1.49mm, 1 Hole 30-030098-10 AF5391 (MLS), 1.57mm, 2 Holes 30-030099-10 AF5401 (MLS), 1.65mm, 3 Holes 30-030100-10	CC5231 ▲ 21-29463-20/0	EB5370 [8] 22-29314-00/0
AJM	1896	4	79.50	PDi	85/116				
AUY	1896	4	79.50	Direct Injection, SOHC	85/116				
Bora 1.9L TDI Diesel				09/00 → 05/05		12	AF5381 (MLS), 1.49mm, 1 Hole 30-030098-10 AF5391 (MLS), 1.57mm, 2 Holes 30-030099-10 AF5401 (MLS), 1.65mm, 3 Holes 30-030100-10	CC5231 ▲ 21-29463-20/0	EB5370 [8] 22-29314-00/0
ATD	1896	4	79.50		74/100				
AXR	1896	4	79.50	PDi, SOHC	74/100				
ASZ	1896	4	79.50	PDi, SOHC	96/131				
Bora 1.9L TDI Diesel				05/00 → 05/05		13	AF5381 (MLS), 1.49mm, 1 Hole 30-030098-10 AF5391 (MLS), 1.57mm, 2 Holes 30-030099-10 AF5401 (MLS), 1.65mm, 3 Holes 30-030100-10	CC5231 ▲ 21-29463-20/0	EB5370 [8] 22-29314-00/0
ARL	1896	4	79.50	PDi	110/150				
Bora 2.0L				10/98 → 05/05		14	AB5370 (MLS) 30-029314-00	CB5370 ■ 21-29314-20/0 APK, AQY, AZH	EB5370 [8] 22-29314-00/0
APK	1984	4	82.50	SOHC	85/116				
AQY/AZG/AZH/AZJ	1984	4	82.50		85/116				
Bora 2.3L V5				10/98 → 10/00		15	AG7800	CG7800	EG7800
AGZ	2324	5	81.00	DOHC, V5	110/150				
Bora 2.3L V5				10/00 → 05/05		16	CG9620 21-30348-00/0 (MLS)		
AQN	2324	5	81.00	DOHC, V5	125/170				

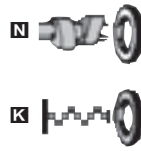
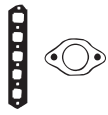

AB5370



BZ010, BZ020, BZ030



BZ040, BZ050, BZ060



JC152



JD170



JD5291



JD5293



JD600



JM5103



JP024

HBS018[Ⓢ]
(22-39024B)
M12x1.75x115mm (x10)

JD170[■]
31-026556-10
JC152[■] (x4)
31-026555-00
AHF
JD600[■]
31-028454-00
ASV

HR397 [57]
34-000410-00

HR816[■]
24-30653-85/0

NA5001[■] 32x47x10mm, FPM
(50-303185-50)
NB716[■] 35x48x10mm, FPM
(50-306067-50)
LK5003[■] [3] 85x131x15.7mm, PTFE
(50-319434-00)

NA5278 [54]

HBS300[Ⓢ]
(22-33034B)
M12x1.75x166mm (x10)

JD170[■]
31-026556-10
JC152[■] (x4)
31-026555-00

HR397 [57]
34-000410-00

HR816[■]
24-30653-85/0

NA5124[■] 32x47x10mm, PTFE
(50-319433-00)
NA5106[■] 35x48x10mm, PTFE
(50-319430-00)
LK5003[■] [3] 85x131x15.7mm, PTFE
(50-319434-00)

HL5034 [245] [■]

HBS300[Ⓢ]
(22-33034B)
M12x1.75x166mm (x10)

JD170[■]
31-026556-10
JC152[■] (x4)
31-026555-00

JM5203
50-029934-00

HR397 [57]
34-000410-00

HR816[■]
24-30653-85/0

NA5124[■] 32x47x10mm, PTFE
(50-319433-00)
NA5106[■] 35x48x10mm, PTFE
(50-319430-00)
LK5003[■] [3] 85x131x15.7mm, PTFE
(50-319434-00)

HL5034 [245] [■]

HBS300[Ⓢ]
(22-33034B)
M12x1.75x166mm (x10)

JD170[■]
31-026556-10
JC152[■] (x4)
31-026555-00

JM5203
50-029934-00

HR397 [57]
34-000410-00

HR816[■]
24-30653-85/0

NA5124[■] 32x47x10mm, PTFE
(50-319433-00)
NA5106[■] 35x48x10mm, PTFE
(50-319430-00)
LK5003[■] [3] 85x131x15.7mm, PTFE
(50-319434-00)

HL5034 [245] [■]

HBS246[Ⓢ]
(22-33024B)
M10x1.50x120mm (x10)

JD5291[■]
(31-029814-00)
APK, AQY, AZG, AZH
JD5340[■] (x4)
(50-029939-00)
AZJ
JD5293[■]
(31-029816-00)

JM5103
(50-029547-00)
AZG, AZJ
JP024
50-027505-00
APK, AQY, AZH

HR397 [57]
34-000410-00
JH5117
(50-030046-00)
APK, AQY, AZH

HR816[■]
24-30653-85/0

NA5124[■] 32x47x10mm, PTFE
(50-319433-00)
NA5106[■] 35x48x10mm, PTFE
(50-319430-00)
LK5003[■] [3] 85x131x15.7mm, PTFE
(50-319434-00)

HL5034 [245] [■]

HBS461
(22-39034B)

HR397 [57]
34-000410-00

NA5106[■] 35x48x10mm, PTFE
(50-319430-00)

JM5234
(50-029982-00)

HR397 [57]
34-000410-00

HR822[■]

NA5106[■] 35x48x10mm, PTFE
(50-319430-00)











































VW



KW/PS



Bora 2.8L V6						03/99 → 05/05	17	AG5000 (MLS)	CG5010	EG7800
AQP	2792	6	81.00	DOHC, V6	150/204		(30-030123-00)	21-30123-10/0		
AUE	2792	6	81.00	V6	150/204			AUE		
BDE	2792	6	81.00	DOHC, V6	150/204			CG5020 21-30123-20/0 AQP CG5030 21-30123-30/0 BDE		
Caddy 1.4L						08/00 → 01/04	18	AB5701 (MLS)	CB5700	EB5700 [8]
Caddy 1.4L 16V						08/00 → 01/04		30-029313-10	21-29313-20/0	22-29313-00/0
Caddy 1.4L 16V Mk III						05/06 →				
AUA	1390	4	76.50	MPi, SOHC	55/75		30-029313-10	21-29313-20/0	22-29313-00/0	
BUD	1390	4	76.50	Injection, DOHC	59/80					
Caddy 1.4L						03/04 →	19	AB5701 (MLS)	CB5700	EB5700 [8]
BCA	1390	4	76.50		55/75		30-029313-10	21-29313-20/0	22-29313-00/0	
Caddy 1.4L						11/95 → 01/04	20	BZ180 (MLS), 0.50mm	CD5640	EB961 [8]
AEX	1390	4	76.50	Injection, SOHC	40/44/ 54/60		30-027910-10	21-29662-20/0	22-28897-03/0	
AKV/APQ/AUD	1390	4	76.50	SOHC	44/60		AEX, AKV, APQ AD5640 (MLS), 0.64mm 30-029662-00 AUD	AUD DZ181 21-27910-21/0 AEX, AKV, APQ	AEX, AKV, APQ	











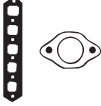

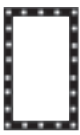

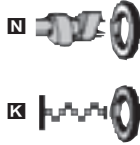







































					 	!	 AD5640  AG5000  BZ180  JD5228  JD5298  JD5318  JD597  JD601  JP074
		JM7045 50-030133-00 (Rubber) BDE	HR397 [57] 34-000410-00	HR5062  24-30614-73/0	NA5106  35x48x10mm, PTFE (50-319430-00)		
HBS249  (22-33025B) M9x1.25x138mm (x10)	JD5228  (x4) (50-029071-00) JD5298  (31-029825-00)	HR397 [57] 34-000410-00	HR397 [57] 34-000410-00	HR791  24-30614-76/0	NA5180  27x42x8mm, FPM (50-319484-00) NA5185  32x42x6mm, FPM (50-319489-00)	KA5025 [13] KK5551 [81]	
HBS249  (22-33025B) M9x1.25x138mm (x10)	JD5228  (x4) (50-029071-00) JD5298  (31-029825-00)	HR397 [57] 34-000410-00	HR397 [57] 34-000410-00	HR791  24-30614-76/0	NA5180  27x42x8mm, FPM (50-319484-00) NA5185  32x42x6mm, FPM (50-319489-00) LK5011  [3] [78] 85x131x15.94mm, PTFE	KA5025 [13] KK5551 [81]	
HBS362  (22-39031B) M9x1.25x162mm (x10)	JD597   50-350355-00 JD5318  (31-029901-00) AUD JD601  (x4) 31-028644-00 AEX, AKV, APQ	JP074 50-027907-00 AEX, AKV, APQ HM5062  24-27907-00/0 AEX, AKV, APQ	HR397 [57] 34-000410-00	HR816  24-30653-85/0 AEX, AKV, APQ HR817  24-30614-78/0 AUD	NA5001  32x47x10mm, FPM (50-303185-50) AEX, AKV, APQ NA5185  32x42x6mm, FPM (50-319489-00) AUD NA5001  32x47x10mm, FPM (50-303185-50) →Eng.AEX 908 121 →Eng.AKV 095 009 NA5133  85x105x11mm, FPM (24-30727-87/0) →Eng.AEX 908 121 →Eng.AKV 095 009 LK5011  [3] [78] 85x131x15.94mm, PTFE AUD NA5185  32x42x6mm, FPM (50-319489-00) Eng.AEX 908 122→ Eng.AKV 095 010→ APQ, AUD LK5006  [3] 85x131x16mm, PTFE (50-319448-00) Eng.AEX 908 122→ Eng.AKV 095 010→ APQ	HL5020 [245]  →Eng.AEX 908 121 →Eng.AKV 095 009	



KW/PS



Caddy 1.6L 06/96 → 12/00 21						BZ180 (MLS), 0.50mm	DZ181	EB961 [8]
Caddy 75 1.6L 11/95 → 09/00						30-027910-10	21-27910-21/0	22-28897-03/0
AEE	1598	4	76.50	Injection, SOHC	55/75			
Caddy 1.6L 04/04 → 22						AC5220 (MLS)	CC5222	
BGU/BSE/BSF	1595	4	81.00	SOHC	75/102	30-029462-00	21-29462-22/0	
Caddy 1.6L 01/83 → 05/97 23						BM360 (Fibre)	DM368	EG873
Caddy 75 1.6L 11/95 → 05/97						30-026807-30	21-26807-20/0	
1F	1595	4	81.00	Monomotronic, SOHC	53/55/ 72/75			
EW	1595	4	81.00		55/75			
Caddy 1.6L D Diesel 08/82 → 07/92 24						BN080 (Fibre), 1.40mm, 1 Notch	DD501▲ [83]	EG873
JK/ME	1588	4	76.50		40/54	30-024901-30 →07/85	21-25753-26/0	
						BN090 (Fibre), 1.50mm, 2 Notches 30-024849-30 →07/85		
						BN100 (Fibre), 1.60mm, 3 Notches 30-024850-30 →07/85		
						BN940 (Fibre), 1.53mm, 1 Hole 30-026230-30 08/85 →		
						BN950 (Fibre), 1.57mm, 2 Holes 30-026231-30 08/85 →		
						BN960 (Fibre), 1.61mm, 3 Holes 30-026232-30 08/85 →		
Caddy 1.7L SDI Diesel 07/96 → 09/00 25						BX800 (MLS), 1.45mm, 1 Hole	DX801▲	EC030 [8]
AHB	1716	4	79.50	SOHC	42/57	30-028686-00	21-27921-21/0	22-26384-04/0
						BX810 (MLS), 1.53mm, 2 Holes 30-028687-00		
						BX820 (MLS), 1.61mm, 3 Holes 30-028688-00		











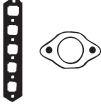

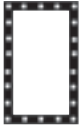

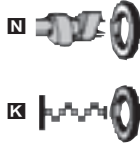











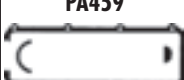

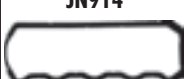

















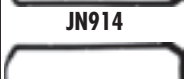







								
HBS075 Ⓞ [22-39011B] M11x1.50x110mm (x10)	JD597 [1] [5] 50-350355-00 JD601 [5] 31-028644-00	JP074 50-027907-00 HM5062 [5] 24-27907-00/0	JJ183 [31-026516-10]	HR816 [5] 24-30653-85/0	NA5001 [3] 32x47x10mm, FPM (50-303185-50) NA5001 [5] 32x47x10mm, FPM (50-303185-50) →Eng.AEE 562 757 NA5133 [5] 85x105x11mm, FPM (24-30727-87/0) →Eng.AEE 562 757 NA5185 [5] 32x42x6mm, FPM (50-319489-00) Eng.AEE 562 758 → LK5006 [3] 85x131x16mm, PTFE (50-319448-00) Eng.AEE 562 758 →	HL5020 [245] [5] →Eng.AEE 562 757	 AC5220  BM360  BN080, BN090, BN100  BN940, BN950, BN960  BX800, BX810, BX820  BZ180  JC152  JC478  JD170  JD5293  JD597  JD601  JE160  PA459  HL457  JP003  JP074  JJ140	 JJ183  JJ609
HBS246 Ⓞ [22-33024B] M10x1.50x120mm (x10)	JD5340 [1] (x4) (50-029939-00) JD5293 [5] (31-029816-00)	JM5205 50-029938-00 (Rubber)	HR397 [57] 34-000410-00	HR817 [5] 24-30614-78/0	NA5124 32x47x10mm, PTFE (50-319433-00) NA5106 [5] 35x48x10mm, PTFE (50-319430-00)	HL5034 [245] [5]		
HBS043 Ⓞ [22-39001B] M11x1.50x95mm (x10)	JC478 [1] 31-026397-00 PA459 [1] 50-024870-00 (NBR) JC152 [5] (x4) 31-026555-00  JE160 (31-024869-00)	HL457 [5] [79] 24-25753-01/0 (Cork) HM5053 [5] [80] 24-28543-00/0 (ACM)	JJ140 [31-026554-10]	HR569 [5] 24-30667-00/0	NA5001 32x47x10mm, FPM (50-303185-50) NA5001 [5] 32x47x10mm, FPM (50-303185-50) NA5133 [5] 85x105x11mm, FPM (24-30727-87/0)	HL5020 [245] [5] KA5020 [13]	 JC152  JC478  JD170  JD5293  JD597  JD601  JE160  PA459  HL457  JP003  JP074  JJ140	
HBS018 Ⓞ [22-39024B] M12x1.75x115mm (x10)	JC478 [1] 31-026397-00	HL457 [5] [79] 24-25753-01/0 (Cork) HM5053 [5] [80] 24-28543-00/0 (ACM)	JJ140 [31-026554-10]	HR569 [5] 24-30667-00/0	NA5001 32x47x10mm, FPM (50-303185-50) NA5001 [5] 32x47x10mm, FPM (50-303185-50) NA5133 [5] 85x105x11mm, FPM (24-30727-87/0)	HL5020 [245] [5] KA5020 [13]	 JC152  JC478  JD170  JD5293  JD597  JD601  JE160  PA459  HL457  JP003  JP074  JJ140	
HBS018 Ⓞ [22-39024B] M12x1.75x115mm (x10)	JD170 [1] 31-026556-10 JC152 [5] (x4) 31-026555-00	JP003 50-027921-00	JJ609 (50-027500-00) (ACM)	HR816 [5] 24-30653-85/0	NA5001 32x47x10mm, FPM (50-303185-50) NA5001 [5] 32x47x10mm, FPM (50-303185-50) NA5133 [5] 85x105x11mm, FPM (24-30727-87/0) →Eng.AHB 005 000 LK5006 [3] 85x131x16mm, PTFE (50-319448-00) Eng.AHB 005 001 →	HL5020 [245] [5]	 JP003  JP074  JJ140	



KWPS

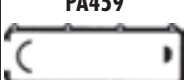

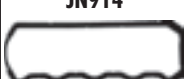
Caddy 1.8L		08/85 → 07/92			26	BM360 (Fibre)	DM368	EG873
JH	1781	4	81.00	K-Jetronic	70/95	30-026807-30	21-26807-20/0	
Caddy 1.9L D Diesel		06/96 → 12/00			27	BV850 (MLS), 1.53mm, 1 Hole 30-028545-00 BV860 (MLS), 1.57mm, 2 Holes 30-028546-00 BV870 (MLS), 1.61mm, 3 Holes 30-028547-00	DV850▲ 21-26557-20/0 → Eng.AEF 007 000 DV851▲ 21-26557-21/0 Eng.AEF 007 001 →	EC030 [8] 22-26384-04/0
AEF	1896	4	79.50		47/64			
Caddy 1.9L D Diesel		11/95 → 01/04			28	BV850 (MLS), 1.53mm, 1 Hole 30-028545-00 BV860 (MLS), 1.57mm, 2 Holes 30-028546-00 BV870 (MLS), 1.61mm, 3 Holes 30-028547-00	DV850▲ 21-26557-20/0 → Eng.IY 580 000 DV851▲ 21-26557-21/0 Eng.IY 580 001 →	EC030 [8] 22-26384-04/0
IY	1896	4	79.50		47/50/ 64/68			
Caddy 1.9L SDI Diesel		11/95 → 01/04			29	BX800 (MLS), 1.45mm, 1 Hole 30-028686-00 AEY BX810 (MLS), 1.53mm, 2 Holes 30-028687-00 AEY BX820 (MLS), 1.61mm, 3 Holes 30-028688-00 AEY BZ040 (MLS), 1.47mm, 1 Hole 30-028915-10 AYQ BZ050 (MLS), 1.57mm, 2 Holes 30-028916-10 AYQ BZ060 (MLS), 1.67mm, 3 Holes 30-028917-10 AYQ	DX801▲ 21-27921-21/0 AEY	EC030 [8] 22-26384-04/0 AEY EC060 [8] 22-28897-00/0 AYQ
AEY/AYQ	1896	4	79.50	SDi	47/64			
Caddy 1.9L TDI Diesel		04/04 →			30	AF5381 (MLS), 1.49mm, 1 Hole 30-030098-10 AF5391 (MLS), 1.57mm, 2 Holes 30-030099-10 AF5401 (MLS), 1.65mm, 3 Holes 30-030100-10	CC5230▲ 21-29463-21/0 BJB	EF5380 22-30369-00/0
BJB BLS	1896 1896	4 4	79.50 79.50	DOHC Direct Injection, SOHC	77/105 77/105			











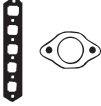

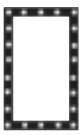

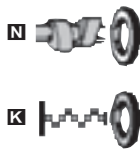





								
HBS043 Ⓞ [22-39001B] M11x1.50x95mm (x10)	JC478 ■ 31-026397-00 PA459 ■ 50-024870-00 (NBR) JC152 ■ (x4) 31-026555-00  (31-024869-00)	HL457 ■ [79] 24-25753-01/0 (Cork) HM5053 ■ [80] 24-28543-00/0 (ACM)	JJ140 [31-026554-10]	HR569 ■ 24-30667-00/0	NA5001 32x47x10mm, FPM (50-303185-50) NA5001 ■ 32x47x10mm, FPM (50-303185-50) NA5133 ■ 85x105x11mm, FPM (24-30727-87/0)	HL5020 [245]■ KA5020 [13]	 BM360  BV850, BV860, BV870  BX800, BX810, BX820  BZ040, BZ050, BZ060  JC152  JC478  JD170  JD600  JE160  PA459  HL457  JN914  JP003  JH5023  JJ140	
HBS018 Ⓞ [22-39024B] M12x1.75x115mm (x10)	JD170 ■ 31-026556-10 JC152 ■ (x4) 31-026555-00  (31-028373-00)	JN914 50-026557-10 HM5058 ■ 24-26557-00/0	JH5023 [31-029043-00]	HR569 ■ 24-30667-00/0 →Eng.AEF 007 HR816 ■ 24-30653-85/0 Eng.AEF 007 001 →	NA5001 32x47x10mm, FPM (50-303185-50) NA5001 ■ 32x47x10mm, FPM (50-303185-50) NA5133 ■ 85x105x11mm, FPM (24-30727-87/0) LK5006 ■ [3] 85x131x16mm, PTFE (50-319448-00) Eng.AEF 265 001 →	HL5020 [245]■ NA5278 [54]	 BZ040, BZ050, BZ060  JC152  JC478  JD170  JD600  JE160  PA459  HL457  JN914  JP003  JH5023  JJ140	
HBS018 Ⓞ [22-39024B] M12x1.75x115mm (x10)	JD170 ■ 31-026556-10 JC152 ■ (x4) 31-026555-00 AEY JD600 ■ 31-028454-00 AYQ  (31-028373-00)	JN914 50-027921-00 AEY JP003 50-029934-00 BJB	JH5023 [31-029043-00]	HR569 ■ 24-30667-00/0 →Eng.IY 580 HR816 ■ 24-30653-85/0 Eng.IY 580 000 →	NA5001 32x47x10mm, FPM (50-303185-50) NA5001 ■ 32x47x10mm, FPM (50-303185-50) NA5133 ■ 85x105x11mm, FPM (24-30727-87/0) →Eng.IY 800 000 LK5006 ■ [3] 85x131x16mm, PTFE (50-319448-00) Eng.IY 800 001 →	HL5020 [245]■	 HL457  JN914  JP003  JH5023  JJ140	
HBS300 Ⓞ [22-33034B] M12x1.75x166mm (x10)	JD170 ■ 31-026556-10 JD600 ■ 31-028454-00 BJB	JM5203 50-029934-00 BJB	HR397 [57] 34-000410-00	HR816 ■ 24-30653-85/0	NA5124 32x47x10mm, PTFE (50-319433-00) NA5106 ■ 35x48x10mm, PTFE (50-319430-00) LK5012 ■ [3] [85] 85x132x15.7mm, ACM (50-319535-00)	HL5034 [245]■	 BM360  BV850, BV860, BV870  BX800, BX810, BX820  BZ040, BZ050, BZ060  JC152  JC478  JD170  JD600  JE160  PA459  HL457  JN914  JP003  JH5023  JJ140	



KWPS



Caddy 1.9L TDI Diesel		09/96 → 01/04		31				
1Z	1896	4	79.50	SOHC	66/89	BX800 (MLS), 1.45mm, 1 Hole 30-028686-00 AHU, ALE, 1Z BX810 (MLS), 1.53mm, 2 Holes 30-028687-00 AHU, ALE, 1Z BX820 (MLS), 1.61mm, 3 Holes 30-028688-00 AHU, ALE, 1Z BZ010 (MLS), 1.45mm, 1 Hole 30-028910-10 →Eng.ALH 085 000 BZ020 (MLS), 1.53mm, 2 Holes 30-028911-10 →Eng.ALH 085 000 BZ030 (MLS), 1.61mm, 3 Holes 30-028912-10 →Eng.ALH 085 000 BZ040 (MLS), 1.47mm, 1 Hole 30-028915-10 Eng.ALH 085 001 → BZ050 (MLS), 1.57mm, 2 Holes 30-028916-10 Eng.ALH 085 001 → BZ060 (MLS), 1.67mm, 3 Holes 30-028917-10 Eng.ALH 085 001 →	DX800▲ 21-27921-20/0 →Eng.1Z-720 000 AHU DZ010▲ ☒ 21-26556-20/0 ALH DX801▲ 21-27921-21/0 Eng.1Z-720 001 → ALE	EC030 [8] 22-26384-04/0 AHU, ALE, 1Z EC060 [8] 22-28897-00/0 ALH
Caddy 1.9L TDI Diesel		09/05 →		32				
BSU	1896	4	79.50	Direct Injection, SOHC	55/75	AF5381 (MLS), 1.49mm, 1 Hole 30-030098-10 AF5391 (MLS), 1.57mm, 2 Holes 30-030099-10 AF5401 (MLS), 1.65mm, 3 Holes 30-030100-10	EF5380 22-30369-00/0	
Caddy 2.0L TDI Mk III Diesel		09/07 →		33				
BMM	1968	4	81.00	Direct Injection, DOHC	103/140	AG9630 (MLS), 1.45mm, 1 Hole 30-030349-00 AG9640 (MLS), 1.53mm, 2 Holes AG9650 (MLS), 1.61mm, 3 Holes	EF5380 22-30369-00/0	
Caddy 2.0L EcoFuel Mk III		04/06 →		34				
BSX	1984	4	82.50	Injection, DOHC	80/109		EB5370 [8] 22-29314-00/0	
Caddy 2.0L SDI Diesel		03/04 →		35				
BDJ	1968	4	81.00	Direct Injection	51/70	AG8940 (MLS), 1.41mm, 1 Hole 30-030246-00 AG8830 (MLS), 1.51mm, 2 Holes 30-030216-00 AG8950 (MLS), 1.61mm, 3 Holes (30-030247-00)	CC5230▲ 21-29463-21/0 EF5380 22-30369-00/0	
BST	1968	4	81.00	Direct Injection, SOHC	51/70			
Corrado Coupe 1.8L 16V		04/89 → 07/92		36				
KR	1781	4	81.00	K-Jetronic	98/133	BM360 (Fibre) 30-026807-30	DM365 21-26807-21/0 ET811 (22-26554-40/0)	











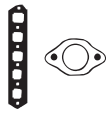

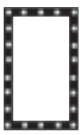

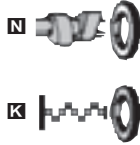

































								
HBS018 ® (22-39024B) M12x1.75x115mm (x10)	JD170 ■ 31-026556-10 JC152 ■ (x4) 31-026555-00	JP003 50-027921-00 AHU, ALE, IZ	HR397 [57] 34-000410-00 ALH JJ609 (50-027500-00) (ACM) AHU, ALE, IZ	HR569 ■ 24-30667-00/0 →Eng.IZ 720 000 AHU HR816 ■ 24-30653-85/0 Eng.IZ 720 001→ ALH, ALE	NA5001 32x47x10mm, FPM (50-303185-50) NB716 ■ 35x48x10mm, FPM (50-306067-50) ALH NA5001 ■ 32x47x10mm, FPM (50-303185-50) AHU, ALE, IZ LK5003 ■ [3] 85x131x15.7mm, PTFE (50-319434-00) ALH NA5133 ■ 85x105x11mm, FPM (24-30727-87/0) →Eng.AHU 390 000 →Eng.ALE 576 000 IZ LK5006 ■ [3] 85x131x16mm, PTFE (50-319448-00) Eng.AHU 390 001→ Eng.ALE 576 001→	HL5020 [245]■	 BM360  BX800, BX810, BX820  BZ010, BZ020, BZ030  BZ040, BZ050, BZ060  JC152  JD170  JD281  JD282  JD5293  JD600  LA5204  JM5103  JP003  JJ140  JJ609	
HBS300 ® (22-33034B) M12x1.75x166mm (x10)	JD170 ■ 31-026556-10		HR397 [57] 34-000410-00	HR816 ■ 24-30653-85/0	NA5124 32x47x10mm, PTFE (50-319433-00) NA5106 ■ 35x48x10mm, PTFE (50-319430-00) LK5012 ■ [3] [85] 85x132x15.7mm, ACM (50-319535-00)	HL5034 [245]■		
HBS300 ® (22-33034B) M12x1.75x166mm (x10)	JD170 ■ 31-026556-10		HR397 [57] 34-000410-00	HR816 ■ 24-30653-85/0	NA5124 32x47x10mm, PTFE (50-319433-00) NA5106 ■ 35x48x10mm, PTFE (50-319430-00) LK5012 ■ [3] [85] 85x132x15.7mm, ACM (50-319535-00)			
HBS246 ® (22-33024B) M10x1.50x120mm (x10)	LA5204 ■ (x4) (50-350416-00) JD5293 ■ (31-029816-00)	JM5103 (50-029547-00)	HR397 [57] 34-000410-00	HR816 ■ 24-30653-85/0	NA5124 32x47x10mm, PTFE (50-319433-00) NA5106 ■ 35x48x10mm, PTFE (50-319430-00) LK5003 ■ [3] 85x131x15.7mm, PTFE (50-319434-00)			
HBS300 ® (22-33034B) M12x1.75x166mm (x10)	JD170 ■ 31-026556-10 JD600 ■ 31-028454-00	JM5203 50-029934-00	HR397 [57] 34-000410-00	HR816 ■ 24-30653-85/0	NA5124 32x47x10mm, PTFE (50-319433-00) NA5106 ■ 35x48x10mm, PTFE (50-319430-00) LK5012 ■ [3] [85] 85x132x15.7mm, ACM (50-319535-00)	HL5034 [245]■		
HBS028 ® (22-39004B) M11x1.50x147mm (x10)	JD281 ■ (31-027904-00) JD282 ■ (x4) (31-026880-00) JF205 (31-025070-00)	HL606 ■ 24-26237-01/0	JJ140 (31-026554-10)	HR816 ■ (x2) 24-30653-85/0	NA5001 32x47x10mm, FPM (50-303185-50) NA5001 ■ 32x47x10mm, FPM (50-303185-50) NA5133 ■ 85x105x11mm, FPM (24-30727-87/0)	HL5020 [245]■		

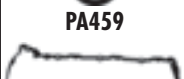

KW/PS

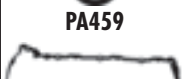

Corrado Coupe 1.8L G60				09/88 → 09/93	37	BY630 (MLS)	DT819
PG	1781	4	81.00	Digifant	118/160	30-027516-00	21-27516-21/0
Corrado Coupe 2.0L i				04/93 → 12/95	38	BT810 (Fibre)	DT816
2E	1984	4	82.50	Digifant	85/115	30-027257-20	21-27257-24/0
ADY	1984	4	82.50	OHV	85/116	2E BY750 (MLS) 30-027930-00 ADY	2E DY753 21-27930-23/0 ADY
Corrado Coupe 2.0L i 16V				08/91 → 12/95	39	BT810 (Fibre)	DT812
9A	1984	4	82.50	KE-Motronic	100/136	30-027257-20 →Eng.9A 131 460 BY750 (MLS) 30-027930-00 Eng.9A 131 461→	21-27257-21/0 →Eng.9A 131 460
Corrado Coupe 2.9L VR6				08/91 → 12/95	40	AA5430 (Fibre)	CA5430
ABV	2861	6	82.00	DOHC, V6	140/190	30-027920-00	21-27920-20/0 →Eng.ABV 023 000
EOS 1.6L FSI				06/06 →	41	AG8850 (MLS)	CG8850
BLF	1598	4	76.50	Injection, DOHC	85/115	(30-030218-00)	21-30218-00/0
EOS 2.0L FSI				03/06 →	42	AG9600 (MLS)	EG9600
BVY/BVZ	1984	4	82.50	Injection, DOHC	110/150	30-030352-00	22-30370-00/0
EOS 2.0L TDI Diesel				06/06 →	43	AG9630 (MLS), 1.45mm, 1 Hole	EF5380
BMM	1968	4	81.00	Direct Injection, DOHC	103/140	30-030349-00 AG9640 (MLS), 1.53mm, 2 Holes AG9650 (MLS), 1.61mm, 3 Holes	22-30369-00/0
EOS 3.2L V6				06/06 →	44	AG9610 (MLS)	CG9610
BUB	3189	6	84.00	DOHC, V6	184/250	30-030350-00	21-30350-00/0
Fox 1.2L				04/05 →	45	AG8840 (MLS)	CG8840
BMD	1198	3	76.50	SOHC	40/54	(30-030217-00)	21-27217-00/0 →Ch.5Z-64-000 001







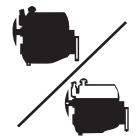



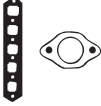

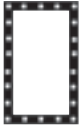







								
HBS043 Ⓞ (22-39001B) M11x1.50x95mm (x10)	JC478 ■ 31-026397-00 PA459 ■ 50-024870-00 (NBR) JC152E (x4) 31-026555-00	JN964 50-026423-10	JJ140 (31-026554-10)	HR569 ■ 24-30667-00/0	NA5001 32x47x10mm, FPM (50-303185-50) NA5001E 32x47x10mm, FPM (50-303185-50) NA5133E 85x105x11mm, FPM (24-30727-87/0)	HL5020 [245]■		 AA5430  JP024  BT810  JH5013  BY630  JH5059
HBS043 Ⓞ (22-39001B) M11x1.50x95mm (x10) 2E	JD483 ■ (31-027352-00) JC152E (x4) 31-026555-00 2E JD600E 31-028454-00 ADY Ⓞ JF205 (31-025070-00)	JP024 50-027505-00	JJ576 (50-027808-00) 2E JJ609 (50-027500-00) (ACM) ADY	HR569 ■ 24-30667-00/0 2E HR816E 24-30653-85/0 ADY	NA5001 32x47x10mm, FPM (50-303185-50) NA5001E 32x47x10mm, FPM (50-303185-50) NA5133E 85x105x11mm, FPM (24-30727-87/0) LK5006E [3] 85x131x16mm, PTFE (50-319448-00)	HL5020 [245]■		 BY750  JA5068  JJ140  JJ576  JJ609
HBS028 Ⓞ (22-39004B) M11x1.50x147mm (x10) →Eng.9A 131 460	JD281 ■ (31-027904-00) JD282E (x4) (31-026880-00) Ⓞ JF205 (31-025070-00)	HL606E 24-26237-01/0	JJ576 (50-027808-00)	HR816E (x2) 24-30653-85/0	NA5001 32x47x10mm, FPM (50-303185-50) NA5001E 32x47x10mm, FPM (50-303185-50) NA5133E 85x105x11mm, FPM (24-30727-87/0)	HL5020 [245]■		 JA5069  JC152  JC478  JD170  JD281  JD282  JD483  JD5109  JD5232
HBS077 Ⓞ (22-39012B) M11x1.50x85mm (x7) M11x1.50x144mm (x3) M11x1.50x119mm (x10)	JD5232 ■ (31-027918-00) JA5068 ■ (31-027917-00) JA5069E [28] (31-027913-00) JD5109E [29] (31-027914-00)	JM5030 50-027915-00 →Eng.ABV 023 000 JM5099 50-029103-00 Eng.ABV 023 001→	JH5013 (31-027911-00) →Eng.ABV 023 000 JH5059 (50-028817-00) Eng.ABV 023 001→	HR602E 24-30670-61/0	NB716E 35x48x10mm, FPM (50-306067-50) NA5133E 85x105x11mm, FPM (24-30727-87/0)			 JD281  JD282  JD483  JD5109  JD5232  JD600  PA459
HBS249 Ⓞ (22-33025B) M9x1.25x138mm (x10)	JD5809 ■ 31-030229-00 JD5814E 31-030234-00	HR397 [57] 34-000410-00	HR397 [57] 34-000410-00	HR791E 24-30614-76/0	NA5106E 35x48x10mm, PTFE (50-319430-00) LK5011E [3] [78] 85x131x15.94mm, PTFE →07/05 LK5013E [3] [118] 85x111x15.5mm 08/05→			 JD282  JD483  JD5109  JD5232  JD600  PA459
HBS363 Ⓞ (22-33038B) M10x1.50x122mm (x10)	JD5873 ■ 50-030353-00 (FPM) JD5813E 31-030233-00		HR397 [57] 34-000410-00	HR791E 24-30614-76/0	NA5124 32x47x10mm, PTFE (50-319433-00) NA5106E 35x48x10mm, PTFE (50-319430-00) LK5008E [3] 85x131x15.7mm, PTFE (50-319472-00)			 JD5109  JD5232  JD600  PA459
HBS300 Ⓞ (22-33034B) M12x1.75x166mm (x10)	JD170 ■ 31-026556-10		HR397 [57] 34-000410-00	HR816E 24-30653-85/0	NA5124 32x47x10mm, PTFE (50-319433-00) NA5106E 35x48x10mm, PTFE (50-319430-00) LK5012E [3] [85] 85x132x15.7mm, ACM (50-319535-00)			 JD600  PA459
HBS466 (22-33039B)	JD5874 ■ 50-030351-00 (FPM)	JM7045 50-030133-00 (Rubber)	HR397 [57] 34-000410-00	HR5062E 24-30614-73/0	NA5106E 35x48x10mm, PTFE (50-319430-00)			 JM5030
HBS479 Ⓞ (22-39036B) M9x1.25x162mm (x8)	JD5807 ■ (x3) 50-030227-00 →Ch.5Z-64-000 001 JD5811 ■ (x3) (50-030231-00) Ch.5Z-64-014 186→ JD5819E 31-030239-00	HR397 [57] 34-000410-00	HR397 [57] 34-000410-00	HL5002E (24-30614-77/0)	NA5106E 35x48x10mm, PTFE (50-319430-00)			 JM5099  JN964



KW/PS

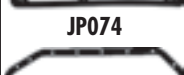

Fox 1.4L TDI Diesel					04/05 →	46		
BNM	1422	3	79.50	Direct Injection, SOHC	51/70	AD5650 (MLS), 1.45mm, 1 Hole 30-029663-00 AD5660 (MLS), 1.53mm, 2 Holes 30-029664-00 AD5670 (MLS), 1.61mm, 3 Holes 30-029665-00	ED5650 [8] (22-29671-00/0)	
Golf 1.0L					08/85 →10/91	47		
HZ	1043	4	75.00		33/37/ 45/50	BL570 (Fibre), 1.73mm 30-024813-20	DL572 21-24813-25/0 →Ch.80-PW-000000 DL573 (21-24813-28/0) Ch.80-PW-000001 →	EV460 22-26516-01/0
Golf 1.3L					08/79 →10/86	48		
GS	1272	4	75.00	SOHC	43/58	BL570 (Fibre), 1.73mm 30-024813-20	DL571 (21-24813-26/0)	EA900 (22-26516-00/0)
GT	1272	4	75.00	SOHC	44/60			
GF	1272	4	75.01		44/60			
Golf 1.3L					08/83 →06/87	49		
HK	1272	4	75.00		40/54	BL570 (Fibre), 1.73mm 30-024813-20	DL570 21-24813-24/0 HK	EA900 (22-26516-00/0) HK
MH	1272	4	75.00	SOHC	40/54		DL572 21-24813-25/0 MH	EV460 22-26516-01/0 MH
Golf 1.3L					06/86 →12/92	50		
2G/MH	1272	4	75.00	SOHC	40/54	BL570 (Fibre), 1.73mm 30-024813-20	DL572 21-24813-25/0 MH	EV460 22-26516-01/0
NZ	1272	4	75.00		40/54		DL574 21-24813-27/0 NZ, 2G	
Golf 1.3L					08/85 →12/87	51		
NU	1272	4	75.00		37/50	BL570 (Fibre), 1.73mm 30-024813-20	DL572 21-24813-25/0	EV460 22-26516-01/0
Golf 1.4L					10/91 →04/99	52		
ABD	1390	4	75.00	Monomotronic	40/44/ 55/60	BZ180 (MLS), 0.50mm 30-027910-10	DL572 21-24813-25/0 ABD → 07/94	EB961 [8] 22-28897-03/0 APQ, AEX
AEX	1390	4	76.50	Injection, SOHC	40/44/ 54/60	APQ, AEX BL570 (Fibre), 1.73mm 30-024813-20	DL574 21-24813-27/0 07/94 → ABD 558 154	EV460 22-26516-01/0 ABD
APQ	1390	4	76.50	SOHC	44/60	ABD	DZ181 21-27910-21/0 APQ, AEX DL573 (21-24813-28/0) Eng.ABD 558 155 →	











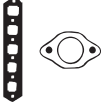

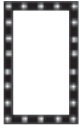

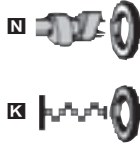
								 AD5650, AD5660, AD5670
HBS264 Ⓞ (22-33026B) M12x1.75x166mm (x8)	JD5278 ■ (31-029671-00) JD5279 ■ (31-029710-00)	JM7032 50-030224-00	HR397 [57] 34-000410-00	HR5068 ■ (24-30653-84/0)	NA5124 32x47x10mm, PTFE (50-319433-00) NA5106 ■ 35x48x10mm, PTFE (50-319430-00) LK5003 ■ [3] 85x131x15.7mm, PTFE (50-319434-00)			 BL570
HBS043 Ⓞ (22-39001B) M11x1.50x95mm (x10)	JD246 ■ (31-026474-20) JC259 ■ (x2) 31-026229-10	JN641 50-025265-10	JJ183 (31-026516-10)	HR569 ■ 24-30667-00/0 →Ch.80-NW- 500 000 HR816 ■ 24-30653-85/0 Ch.80-PW-000 001→	NA5001 32x47x10mm, FPM (50-303185-50) NA5001 ■ 32x47x10mm, FPM (50-303185-50) NA5133 ■ 85x105x11mm, FPM (24-30727-87/0)	HL5020 [245]■		 BZ180
HBS043 Ⓞ (22-39001B) M11x1.50x95mm (x10)	JD246 ■ (31-026474-20) JC259 ■ (x2) 31-026229-10 Ⓞ JE154	JM154 31-024942-10 JN783 [116]	JJ183 (31-026516-10)	HR569 ■ 24-30667-00/0	NA5001 32x47x10mm, FPM (50-303185-50) NA5001 ■ 32x47x10mm, FPM (50-303185-50) NA5133 ■ 85x105x11mm, FPM (24-30727-87/0)	HL5020 [245]■		 JC259
HBS029 Ⓞ (22-33022B) M11x1.50x98mm (x10) HK HBS043 Ⓞ (22-39001B) M11x1.50x95mm (x10) MH	JD246 ■ (31-026474-20) JC259 ■ (x2) 31-026229-10 Ⓞ JE154	JM154 31-024942-10 HK JN641 50-025265-10 MH	JJ183 (31-026516-10)	HR569 ■ 24-30667-00/0	NA5001 32x47x10mm, FPM (50-303185-50) NA5001 ■ 32x47x10mm, FPM (50-303185-50) NA5133 ■ 85x105x11mm, FPM (24-30727-87/0)	HL5020 [245]■		 JD246
HBS043 Ⓞ (22-39001B) M11x1.50x95mm (x10)	JD246 ■ (31-026474-20) JC259 ■ (x2) 31-026229-10	JN641 50-025265-10	JJ183 (31-026516-10)	HR569 ■ 24-30667-00/0 MH HR816 ■ 24-30653-85/0 NZ, 2G	NA5001 32x47x10mm, FPM (50-303185-50) NA5001 ■ 32x47x10mm, FPM (50-303185-50) NA5133 ■ 85x105x11mm, FPM (24-30727-87/0)	HL5020 [245]■		 JD5278
HBS043 Ⓞ (22-39001B) M11x1.50x95mm (x10)	JD246 ■ (31-026474-20) JC259 ■ (x2) 31-026229-10	JN641 50-025265-10	JJ183 (31-026516-10)	HR569 ■ 24-30667-00/0	NA5001 32x47x10mm, FPM (50-303185-50) NA5001 ■ 32x47x10mm, FPM (50-303185-50) NA5133 ■ 85x105x11mm, FPM (24-30727-87/0)	HL5020 [245]■		 JD5279
HBS043 Ⓞ (22-39001B) M11x1.50x95mm (x10)	JD246 ■ (31-026474-20) JC259 ■ (x2) 31-026229-10	JN641 50-025265-10	JJ183 (31-026516-10)	HR569 ■ 24-30667-00/0	NA5001 32x47x10mm, FPM (50-303185-50) NA5001 ■ 32x47x10mm, FPM (50-303185-50) NA5133 ■ 85x105x11mm, FPM (24-30727-87/0)	HL5020 [245]■		 JD597
HBS043 Ⓞ (22-39001B) M11x1.50x95mm (x10) ABD HBS075 Ⓞ (22-39011B) M11x1.50x110mm (x10) AEX / APQ	JD246 ■ (31-026474-20) ABD JD597 ■ ■ 50-350355-00 APQ, AEX JC259 ■ (x2) 31-026229-10 ABD →07/94 JD601 ■ 31-028644-00 ABD 08/94 → APQ, AEX	JN641 50-025265-10 →Eng.ABD 558 154 JP074 50-027907-00 Eng.ABD 558 155→ APQ, AEX HM5062 ■ 24-27907-00/0 Eng.ABD 558 155→ APQ, AEX	HR397 [57] 34-000410-00 APQ, AEX JJ183 (31-026516-10) ABD	HR569 ■ 24-30667-00/0 ABD →07/92 HR816 ■ 24-30653-85/0 ABD 07/92→ APQ, AEX	NA5001 32x47x10mm, FPM (50-303185-50) NA5001 ■ 32x47x10mm, FPM (50-303185-50) →Eng.AEX 908 121 ABD NA5133 ■ 85x105x11mm, FPM (24-30727-87/0) →Eng.AEX 908 121 ABD NA5185 ■ 32x42x6mm, FPM (50-319489-00) Eng.AEX 908 122→ APQ LK5006 ■ [3] 85x131x16mm, PTFE (50-319448-00) Eng.AEX 908 122→ APQ	HL5020 [245]■ KA5025 [13]		 JD601
								 JE154
								 JM154
								 JN641
								 JP074
								 JJ183



KW/PS



Golf 1.4L 16V						08/97 → 06/05	53	AB5701 (MLS)	CB5700	EB5700 [8]
Golf 1.4L 16V Mk V						05/06 →		30-029313-10	21-29313-20/0	22-29313-00/0
Golf 1.4L 16V Plus Mk V						01/05 →				
AHW/AKQ	1390	4	76.50			55/75				
APE	1390	4	76.50	MPi, DOHC		55/75				
AXP	1390	4	76.50	DOHC		55/75				
BCA	1390	4	76.50			55/75				
BUD	1390	4	76.50	Injection, DOHC		59/80				
Golf 1.4L FSI						10/03 →	54	AG8850 (MLS)	CG8850	
Golf 1.4L FSI Plus						07/05 → 05/06		(30-030218-00)	21-30218-00/0	
BKG	1390	4	76.50	Injection		66/89				
BLN	1390	4	76.50	Injection, DOHC		66/90				
Golf 1.6L FSI Mk IV						10/03 → 07/04	55	AG8850 (MLS)	CG8850	
Golf 1.6L FSI						10/03 →		(30-030218-00)	21-30218-00/0	
BAG/BLF/BLP	1598	4				85/116				
	1598	4	76.50	Injection, DOHC		85/115				
Golf 1.6L						08/97 → 02/00	56	AC5220 (MLS)	CC5221	EC080 [8]
AEH	1595	4	81.00	Motronic		74/100	30-029462-00	21-29462-21/0	(22-28897-01/0)	
AKL	1595	4	81.00			74/100	APF	APF	AEH, AKL	
APF	1595	4	81.00	SOHC		74/100	AY980 (MLS)	CY980	EC5220 [8]	
							30-028925-00	21-28925-20/0	(22-29462-00/0)	
							AEH, AKL	AEH, AKL	APF	
Golf 1.6L						08/00 → 06/05	57	AC5220 (MLS)	CC5222	EC5220 [8]
AVU/BFQ	1595	4	81.00	SOHC		75/102	30-029462-00	21-29462-22/0	(22-29462-00/0)	
BJH	1595	4	81.00	Injection, SOHC		75/102				
Golf 1.6L						02/86 → 12/92	58	BM360 (Fibre)	DM368	EG873
Golf Cabriolet 1.6L						08/83 → 04/92		30-026807-30	21-26807-20/0	
PN	1595	4	81.00			51/70				
RE/RF	1595	4	81.00			53/72				
EW	1595	4	81.00			55/75				
HN	1595	4	81.00	SOHC		55/75				
Golf 1.6L						08/83 → 07/92	59	BM360 (Fibre)	DM366	EG873
ABN/EZ	1595	4	81.00			55/75	30-026807-30	21-26807-26/0		
HM	1595	4	81.00	SOHC		55/75		ABN		
								DM368		
								21-26807-20/0		
								EZ, HM		

								
HBS249 ® (22-33025B) M9x1.25x138mm (x10)	JD5228 ■ (x4) (50-029071-00) JD5298 ■ (31-029825-00)	HR397 [57] 34-000410-00	HR397 [57] 34-000410-00	HR791 ■ 24-30614-76/0	NA5180 (x2) 27x42x8mm, FPM (50-319484-00) NA5185 ■ 32x42x6mm, FPM (50-319489-00) LK5011 ■ [3] [78] 85x131x15.94mm, PTFE BCA	KA5025 [13] KK5551 [81]		
HBS249 ® (22-33025B) M9x1.25x138mm (x10)	JD5809 ■ 31-030229-00 JD5814 ■ 31-030234-00	HR397 [57] 34-000410-00	HR397 [57] 34-000410-00	HR791 ■ 24-30614-76/0	NA5106 ■ 35x48x10mm, PTFE (50-319430-00) LK5013 ■ [3] [118] 85x111x15.5mm			
HBS249 ® (22-33025B) M9x1.25x138mm (x10)	JD5809 ■ 31-030229-00 JD5814 ■ 31-030234-00	HR397 [57] 34-000410-00	HR397 [57] 34-000410-00	HR791 ■ 24-30614-76/0	NA5106 ■ 35x48x10mm, PTFE (50-319430-00) LK5011 ■ [3] [78] 85x131x15.94mm, PTFE →07/05 LK5013 ■ [3] [118] 85x111x15.5mm 08/05 →			
HBS246 ® (22-33024B) M10x1.50x120mm (x10)	JD5340 ■ (50-029939-00) APF JD607 ■ 50-028924-00 AEH, AKL JD5293 ■ (31-029816-00) APF JD600 ■ (x4) 31-028454-00 AEH, AKL ☉ JF211 (31-028926-00)	JP024 50-027505-00	HR397 [57] 34-000410-00 JH5117 (50-030046-00)	HR816 ■ 24-30653-85/0	NA5124 32x47x10mm, PTFE (50-319433-00) NA5106 ■ 35x48x10mm, PTFE (50-319430-00) LK5008 ■ [3] 85x131x15.7mm, PTFE (50-319472-00)	HL5034 [245] ■		
HBS246 ® (22-33024B) M10x1.50x120mm (x10)	JD5340 ■ (x4) (50-029939-00) JD5293 ■ (31-029816-00)	JM5205 50-029938-00 (Rubber)	HR397 [57] 34-000410-00	HR817 ■ 24-30614-78/0	NA5124 32x47x10mm, PTFE (50-319433-00) NA5106 ■ 35x48x10mm, PTFE (50-319430-00) LK5008 ■ [3] 85x131x15.7mm, PTFE (50-319472-00)	HL5034 [245] ■		
HBS043 ® (22-39001B) M11x1.50x95mm (x10)	JC478 ■ 31-026397-00 PA459 ■ 50-024870-00 (NBR) JC152 ■ (x4) 31-026555-00 ☉ JE160 (31-024869-00)	HL457 ■ [79] 24-25753-01/0 (Cork) HM5053 ■ [80] 24-28543-00/0 (ACM)	JJ140 (31-026554-10)	HR569 ■ 24-30667-00/0	NA5001 32x47x10mm, FPM (50-303185-50) NA5001 ■ 32x47x10mm, FPM (50-303185-50) NA5133 ■ 85x105x11mm, FPM (24-30727-87/0)	HL5020 [245] ■ KA5020 [13]		
HBS043 ® (22-39001B) M11x1.50x95mm (x10)	JC478 ■ 31-026397-00 PA459 ■ 50-024870-00 (NBR) JC152 ■ (x4) 31-026555-00 ☉ JE160 (31-024869-00)	HL457 ■ [79] 24-25753-01/0 (Cork) HM5053 ■ [80] 24-28543-00/0 (ACM)	JJ140 (31-026554-10)	HR569 ■ 24-30667-00/0	NA5001 32x47x10mm, FPM (50-303185-50) NA5001 ■ 32x47x10mm, FPM (50-303185-50) NA5133 ■ 85x105x11mm, FPM (24-30727-87/0)	HL5020 [245] ■ KA5020 [13]		

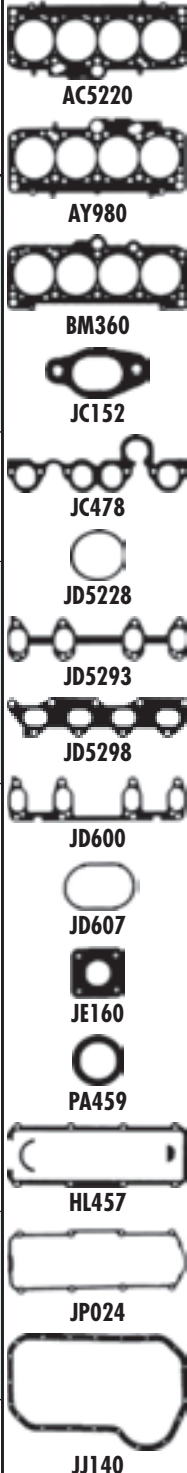



KW/PS



Golf 1.6L				09/92 → 12/97		60	BY620 (Fibre)		DY620	EB961 [8]
ABU	1598	4	76.50	Monomotronic	55/75	30-027905-00	ABU	21-27905-20/0	22-28897-03/0	
AEA	1598	4	76.50	SOHC	55/75	ABU	AEV			
AEE	1598	4	76.50	Injection, SOHC	55/75	BZ180 (MLS), 0.50mm	AEV	DZ180	EV460	
						30-027910-10	ABU, AEA	21-27910-20/0	22-26516-01/0	
								AEV	ABU, AEA	
								21-27910-21/0		
								AEV		
Golf 1.6L				01/04 →		61	AC5220 (MLS)		CC5222	
BGU/BSE/BSF	1595	4	81.00	SOHC	75/102	30-029462-00		21-29462-22/0		
Golf 1.6L				07/94 → 04/99		62	AY940 (MLS)		CY940	EB970
						30-028383-00		21-28383-20/0	22-27500-01/0	
Golf Cabriolet 1.6L				10/94 → 05/98				AEK	AEK	
AEK/AFT/AKS	1595	4	81.00	SOHC	74/100			CY941		
								21-28383-21/0		
								AFT, AKS		
Golf 1.6L 16V				02/00 → 06/05		63	AC5280 (MLS)		CC5280 [41]	EB5700 [8]
AUS/AZD	1598	4	76.50	DOHC	77/105	30-029466-00		21-29466-20/0	22-29313-00/0	
BCB	1598	4	76.50	DOHC	77/105			ATN, AUS		
ATN	1598	4	81.00	SOHC	75/102			CC5281 [41]		
								21-29466-21/0		
								AZD, BCB		
Golf 1.6L D Diesel				08/83 → 10/91		64	BN080 (Fibre), 1.40mm, 1 Notch		DD501 [83]	EG873
JP/ME	1588	4	76.50		40/54	30-024901-30		21-25753-26/0		
						→07/85				
						BN090 (Fibre), 1.50mm, 2 Notches				
						30-024849-30				
						→07/85				
						BN100 (Fibre), 1.60mm, 3 Notches				
						30-024850-30				
						→07/85				
						BN940 (Fibre), 1.53mm, 1 Hole				
						30-026230-30				
						08/85 →				
						BN950 (Fibre), 1.57mm, 2 Holes				
						30-026231-30				
						08/85 →				
						BN960 (Fibre), 1.61mm, 3 Holes				
						30-026232-30				
						08/85 →				
Golf 1.6L FSI				01/02 → 06/05		65	AC5280 (MLS)			
BAD	1598	4	76.50		81/110	30-029466-00				

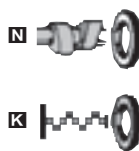
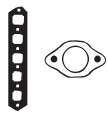

HBS075 Ⓞ [22-39011B] M11x1.50x110mm (x10)	JD487 ■ (31-027908-00) ABU, AEA JD597 ■ ■ 50-350355-00 AEE JD601 ■ 31-028644-00 JE154	JN641 50-025265-10 ABU JP074 50-027907-00 AEA, AEE HM5062 ■ 24-27907-00/0 AEA, AEE	HR397 [57] 34-000410-00 AEE JJ183 (31-026516-10) ABU, AEA	HR816 ■ 24-30653-85/0	NA5001 32x47x10mm, FPM (50-303185-50) NA5001 ■ 32x47x10mm, FPM (50-303185-50) →Eng.AEE 562 757 ABU, AEA NA5133 ■ 85x105x11mm, FPM (24-30727-87/0) →Eng.AEE 562 757 ABU, AEA NA5185 ■ 32x42x6mm, FPM (50-319489-00) Eng.AEE 562 758 → LK5006 ■ [3] 85x131x16mm, PTFE (50-319448-00) Eng.AEE 562 758 →	HL5020 [245]■ →Eng.AEE 562 757
HBS246 Ⓞ [22-33024B] M10x1.50x120mm (x10)	JD5340 ■ (x4) (50-029939-00) JD5293 ■ (31-029816-00)	JM5205 50-029938-00 (Rubber)	HR397 [57] 34-000410-00	HR817 ■ 24-30614-78/0	NA5124 32x47x10mm, PTFE (50-319433-00) NA5106 ■ 35x48x10mm, PTFE (50-319430-00)	HL5034 [245]■
HBS043 Ⓞ [22-39001B] M11x1.50x95mm (x10)	JD599 ■ ■ (31-027926-00) JD600 ■ 31-028454-00 JF205 (31-025070-00)	JP024 50-027505-00	JJ609 (50-027500-00) (ACM)	HR569 ■ 24-30667-00/0 AEK HR816 ■ 24-30653-85/0 AFT, AKS	NA5001 32x47x10mm, FPM (50-303185-50) NA5001 ■ 32x47x10mm, FPM (50-303185-50) NA5133 ■ 85x105x11mm, FPM (24-30727-87/0)	HL5020 [245]■ NA5278 [54]
HBS316 Ⓞ [22-33036B] M9x1.25x97mm (x10)	JD5228 ■ (x4) (50-029071-00) AZD, BCB JD5373 ■ (31-029966-00) ATN, AUS JD5298 ■ (31-029825-00)	HR397 [57] 34-000410-00	HR397 [57] 34-000410-00	HR791 ■ 24-30614-76/0	NA5180 27x42x8mm, FPM (50-319484-00) NA5185 ■ 32x42x6mm, FPM (50-319489-00) LK5011 ■ [3] [78] 85x131x15.94mm, PTFE ATN, AUS	KK5551 [81]
HBS018 Ⓞ [22-39024B] M12x1.75x115mm (x10)	JC478 ■ 31-026397-00 JC152 ■ (x4) 31-026555-00	HL457 ■ [79] 24-25753-01/0 (Cork) HM5053 ■ [80] 24-28543-00/0 (ACM)	JJ140 (31-026554-10)	HR569 ■ 24-30667-00/0	NA5001 32x47x10mm, FPM (50-303185-50) NA5001 ■ 32x47x10mm, FPM (50-303185-50) NA5133 ■ 85x105x11mm, FPM (24-30727-87/0)	HL5020 [245]■ KA5020 [13]
HBS316 Ⓞ [22-33036B] M9x1.25x97mm (x10)	JD5809 ■ 31-030229-00 JD5298 ■ (31-029825-00)	HR397 [57] 34-000410-00	HR397 [57] 34-000410-00	HR791 ■ 24-30614-76/0	NA5180 27x42x8mm, FPM (50-319484-00) NA5185 ■ 32x42x6mm, FPM (50-319489-00)	

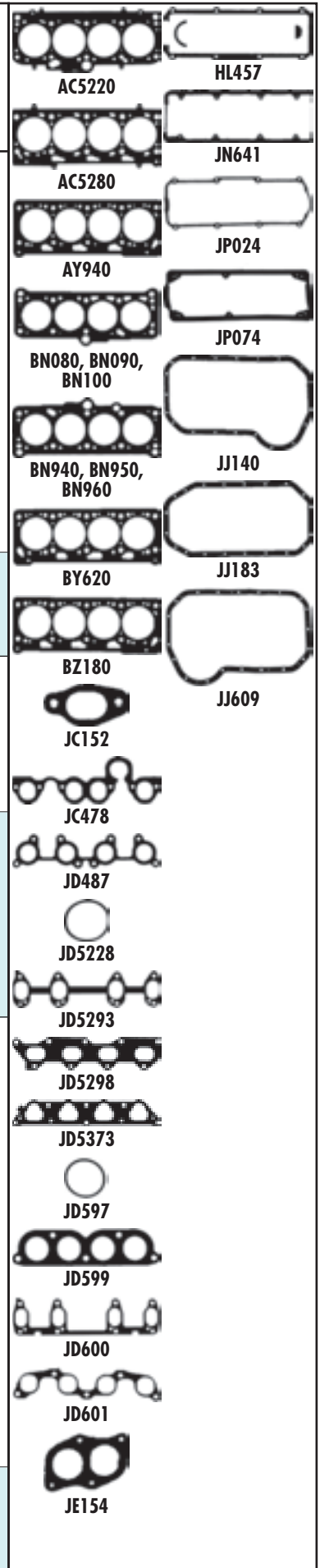







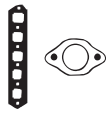

KW/PS

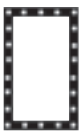

Golf 1.6L TD Diesel				08/83 → 10/91	66			DD502▲ [83] (21-25753-27/0)	EG873
JR/MF	1588	4	76.50		51/70	BN080 (Fibre), 1.40mm, 1 Notch 30-024901-30 →07/85 BN090 (Fibre), 1.50mm, 2 Notches 30-024849-30 →07/85 BN100 (Fibre), 1.60mm, 3 Notches 30-024850-30 →07/85 BN940 (Fibre), 1.53mm, 1 Hole 30-026230-30 08/85→ BN950 (Fibre), 1.57mm, 2 Holes 30-026231-30 08/85→ BN960 (Fibre), 1.61mm, 3 Holes 30-026232-30 08/85→			
Golf 1.6L TD Diesel				04/89 → 10/91	67			DD502▲ [83] (21-25753-27/0)	EG873
1V	1588	4	76.50		44/60	BN940 (Fibre), 1.53mm, 1 Hole 30-026230-30 BN950 (Fibre), 1.57mm, 2 Holes 30-026231-30 BN960 (Fibre), 1.61mm, 3 Holes 30-026232-30			
RA/SB	1588	4	76.50		59/80				
Golf Cabriolet 1.6L				06/98 → 06/02	68			CY941 21-28383-21/0	
AFT/AKS	1595	4	81.00	SOHC	74/100	AY940 (MLS) 30-028383-00			
Golf 1.8L				08/86 → 01/90	69			DM368 21-26807-20/0	EG873
RH	1781	4	81.00		62/84	BM360 (Fibre) 30-026807-30			

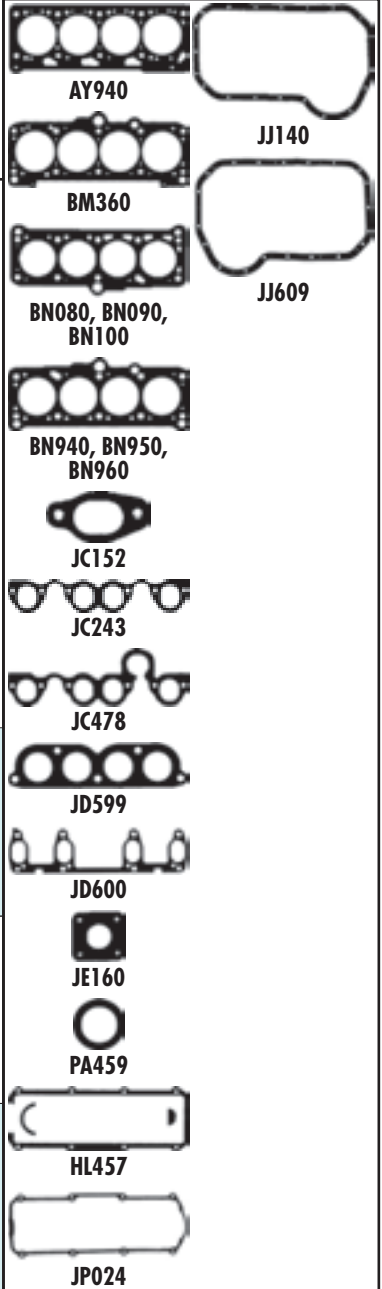
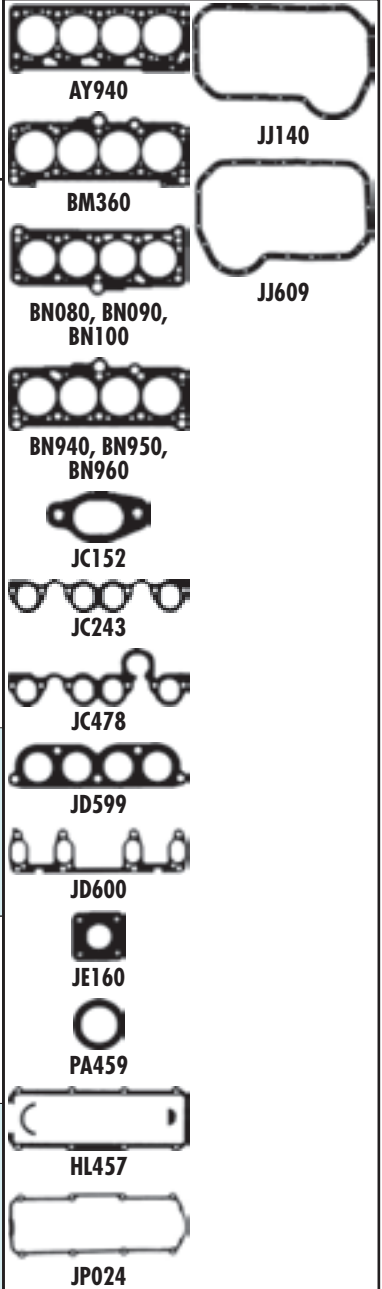
								
HBS018 Ⓢ (22-39024B) M12x1.75x115mm (x10)	JC243 ■ (31-026727-00) JC152 ■ (x4) 31-026555-00 Ⓢ JE160 (31-024869-00)	HL457 ■ [79] 24-25753-01/0 (Cork) HM5053 ■ [80] 24-28543-00/0 (ACM)	JJ140 (31-026554-10)	HR569 ■ 24-30667-00/0	NA5001 32x47x10mm, FPM (50-303185-50) NA5001 ■ 32x47x10mm, FPM (50-303185-50) NA5133 ■ 85x105x11mm, FPM (24-30727-87/0)	HL5020 [245]■ KA5020 [13] NA5278 [54]		
HBS018 Ⓢ (22-39024B) M12x1.75x115mm (x10)	JC243 ■ (31-026727-00) JC152 ■ (x4) 31-026555-00	HL457 ■ [79] 24-25753-01/0 (Cork) HM5053 ■ [80] 24-28543-00/0 (ACM)	JJ140 (31-026554-10)	HR569 ■ 24-30667-00/0	NA5001 32x47x10mm, FPM (50-303185-50) NA5001 ■ 32x47x10mm, FPM (50-303185-50) NA5133 ■ 85x105x11mm, FPM (24-30727-87/0)	HL5020 [245]■ KA5020 [13] NA5278 [54]		
HBS043 Ⓢ (22-39001B) M11x1.50x95mm (x10)	JD599 ■ ■ (31-027926-00) JD600 ■ 31-028454-00 Ⓢ JF205 (31-025070-00)	JP024 50-027505-00	JJ609 (50-027500-00) (ACM)	HR816 ■ 24-30653-85/0	NA5001 32x47x10mm, FPM (50-303185-50) NA5001 ■ 32x47x10mm, FPM (50-303185-50) NA5133 ■ 85x105x11mm, FPM (24-30727-87/0)	HL5020 [245]■ NA5278 [54]		
HBS043 Ⓢ (22-39001B) M11x1.50x95mm (x10)	JC478 ■ 31-026397-00 PA459 ■ 50-024870-00 (NBR) JC152 ■ (x4) 31-026555-00 Ⓢ JE160 (31-024869-00)	HL457 ■ [79] 24-25753-01/0 (Cork) HM5053 ■ [80] 24-28543-00/0 (ACM)	JJ140 (31-026554-10)	HR569 ■ 24-30667-00/0	NA5001 32x47x10mm, FPM (50-303185-50) NA5001 ■ 32x47x10mm, FPM (50-303185-50) NA5133 ■ 85x105x11mm, FPM (24-30727-87/0)	HL5020 [245]■ KA5020 [13]		



KW/PS

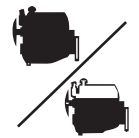

Golf 1.8L		11/91 → 08/97		70		BM360 (Fibre) 30-026807-30 →Eng.AAM 408 197 BZ910 (MLS) 30-027935-00 Eng.AAM 408 198 →	DM366 21-26807-26/0 →Ch.1 HPB 140 000 →Ch.1 HPP 490 000 →Ch.1 HPW 490 000 DM367 21-26807-30/0 Ch.1 HPB 140 001 → Ch.1 HPP 490 001 → Ch.1 HPW 490 001 → →Eng.AAM 408 197 DZ910 21-27935-20/0 Eng.AAM 408 198 →
Golf Cabriolet 1.8L		07/93 → 05/98					
AAM	1781	4	81.00	Monomotronic	55/75		

Golf 1.8L		11/91 → 08/97		71		BM360 (Fibre) 30-026807-30 →Eng.ABS 935 645 →Eng.ADZ 011 565 BZ910 (MLS) 30-027935-00 Eng.ABS 935 646 → Eng.ADZ 011 566 → ACC	DM366 21-26807-26/0 →Ch.1 HPB 140 000 →Ch.1 HPP 490 000 →Ch.1 HPW 490 000 DM367 21-26807-30/0 Ch.1 HPB 140 001 → Ch.1 HPP 490 001 → Ch.1 HPW 490 001 → →Eng.ABS 935 645 →Eng.ADZ 011 565 DZ910 21-27935-20/0 Eng.ABS 935 646 → Eng.ADZ 011 566 → ACC
Golf 1.8L Syncro		01/93 → 08/97					
Golf Cabriolet 1.8L		07/93 → 05/98					
ABS	1781	4	81.00	Monomotronic	66/89		
ACC/ADZ	1781	4	81.00	SOHC	66/89		

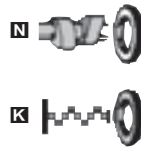
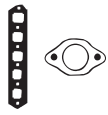

BM360



BZ910



JC152



JC478



JD5235



PA459



HL457



JP024



JJ140

JJ140

HBS043Ⓞ
(22-39001B)
M11x1.50x95mm (x10)

JC478■
31-026397-00
→Eng.AAM 408 197
PA459■
50-024870-00
(NBR)
→Eng.AAM 408 197
JD5235■
(31-028554-00)
Eng.AAM 408 198 →
JC152■ (x4)
31-026555-00
Ⓞ**JE5076**
(31-028373-00)

JP024
50-027505-00
Ch.1 HPB 140
001 →
Ch.1 HPP 490
001 →
Ch.1 HPW 490
001 →
HL457■ [79]
24-25753-01/0
(Cork)
→Ch.1 HPB 140
000
→Ch.1 HPP 490
000
→Ch.1 HPW 490
000
HM5053■ [80]
24-28543-00/0
(ACM)
→Ch.1 HPB 140
000
→Ch.1 HPP 490
000
→Ch.1 HPW 490
000

JJ140
(31-026554-10)

HR569■
24-30667-00/0
→Eng.AAM 408
197
HR816■
24-30653-85/0
Eng.AAM 408
198 →

■ **NA5001** 32x47x10mm, FPM
(50-303185-50)
■ **NA5001**■ 32x47x10mm, FPM
(50-303185-50)
■ **NA5133**■ 85x105x11mm, FPM
(24-30727-87/0)

HL5020 [245]■

HBS043Ⓞ
(22-39001B)
M11x1.50x95mm (x10)

JC478■
31-026397-00
→Eng.ABS 935 645
→Eng.ADZ 011 565
PA459■
50-024870-00
(NBR)
→Eng.ABS 935 645
→Eng.ADZ 011 565
JD5235■
(31-028554-00)
Eng.ABS 935 646 →
Eng.ADZ 011 565 →
ACC
JC152■ (x4)
31-026555-00
Ⓞ**JE5076**
(31-028373-00)

JP024
50-027505-00
Ch.1 HPB 140
001 →
Ch.1 HPP 490
001 →
Ch.1 HPW 490
001 →
ACC
HL457■ [79]
24-25753-01/0
(Cork)
→Ch.1 HPB 140
000
→Ch.1 HPP 490
000
→Ch.1 HPW 490
000
HM5053■ [80]
24-28543-00/0
(ACM)
→Ch.1 HPB 140
000
→Ch.1 HPP 490
000
→Ch.1 HPW 490
000

JJ140
(31-026554-10)

HR569■
24-30667-00/0
→Eng.ABS 935
645
→Eng.ADZ 011
565
HR816■
24-30653-85/0
Eng.ABS 935
646 →
Eng.ADZ 011
566 →
ACC

■ **NA5001** 32x47x10mm, FPM
(50-303185-50)
■ **NA5001**■ 32x47x10mm, FPM
(50-303185-50)
■ **NA5133**■ 85x105x11mm, FPM
(24-30727-87/0)

HL5020 [245]■



KW/PS



Golf 1.8L				07/93 → 04/99		72	BM360 (Fibre)	DM366
ABS	1781	4	81.00	Monomotronic	66/89	30-026807-30	21-26807-26/0	
ADZ	1781	4	81.00	SOHC	66/89	→Eng.ABS 935 645	→Ch.1 HPB 140 000	
ANP	1781	4	81.00		66/89	→Eng.ADZ 011 565	→Ch.1 HPP 490 000	
						BZ910 (MLS) 30-027935-00	→Ch.1 HPW 490 000	
						Eng.ABS 935 646→	DM367 21-26807-30/0	
						Eng.ADZ 011 566→	Ch.1 HPB 140 001→	
						ANP	Ch.1 HPP 490 001→	
							Ch.1 HPW 490 001→	
							→Eng.ABS 935 645	
							→Eng.ADZ 011 565	
							DZ910 21-27935-20/0	
							Eng.ABS 935 646→	
							Eng.ADZ 011 566→	
							ANP	
Golf 1.8L				08/84 → 10/91		73	BM360 (Fibre)	DM368
Golf 1.8L GTI				08/82 → 10/91			30-026807-30	21-26807-20/0
Golf 1.8L i				08/87 → 10/91				08/83→
Golf 1.8L i Syncro				08/87 → 10/91				
Golf 1.8L Syncro				02/86 → 07/91				
Golf Cabriolet 1.8L				08/82 → 04/93				EG873
EX/GU/GX/GZ/HV/RP	1781	4	81.00		66/89			
JH	1781	4	81.00	K-Jetronic	70/95			
1P	1781	4	81.00	SOHC	72/98			
HT	1781	4	81.00	SOHC	74-77/ 100- 104			
PF	1781	4	81.00	Digifant	79/107			
RD	1781	4	81.00		79/107			
DX	1781	4	81.00	K-Jetronic	82/111			
EV	1781	4	81.00		82/111			
JJ	1781	4	81.00	SOHC	82/111			
PB	1781	4	81.00	Digifant	82/111			
Golf 1.8L 4motion				05/98 → 06/05		74	AY970 (MLS)	EY841
AGN	1781	4	81.00	Injection, DOHC	92/125	30-028495-00	22-28897-02/0	
Golf 1.8L GTI 16V				02/86 → 10/91		75	BM360 (Fibre)	DM365
PL	1781	4	81.00	K-Jetronic	95/129	30-026807-30	21-26807-21/0	
KR	1781	4	81.00	K-Jetronic	98/133		ET811 (22-26554-40/0)	

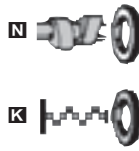
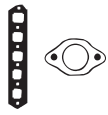

HBS043Ⓞ
(22-39001B)
M11x1.50x95mm (x10)

JC478■
31-026397-00
→Eng.ABS 935 645
→Eng.ADZ 011 565
PA459■
50-024870-00
(NBR)
→Eng.ABS 935 645
→Eng.ADZ 011 565
JD5235■
(31-028554-00)
Eng.ABS 935 646 →
Eng.ADZ 011 565 →
ANP
JC152■ (x4)
31-026555-00
Ⓞ**JE5076**
(31-028373-00)

JP024
50-027505-00
Ch.1 HPB 140
001 →
Ch.1 HPP 490
001 →
Ch.1 HPW 490
001 →
ANP
HL457■ [79]
24-25753-01/0
(Cork)
→Ch.1 HPB 140
000
→Ch.1 HPP 490
000
→Ch.1 HPW 490
000
HM5053■ [80]
24-28543-00/0
(ACM)
→Ch.1 HPB 140
000
→Ch.1 HPP 490
000
→Ch.1 HPW 490
000

JJ140
(31-026554-10)

HR569■
24-30667-00/0
→Eng.ABS 935
645
→Eng.ADZ 011
565
HR816■
24-30653-85/0
Eng.ABS 935
646 →
Eng.ADZ 011
566 →
ANP

■ **NA5001** 32x47x10mm, FPM
(50-303185-50)
■ **NA5001**■ 32x47x10mm, FPM
(50-303185-50)
■ **NA5133**■ 85x105x11mm, FPM
(24-30727-87/0)
ABS, ADZ
■ **LK5006**■ [3] 85x131x16mm, PTFE
(50-319448-00)
ANP

HL5020 [245]■

HBS043Ⓞ
(22-39001B)
M11x1.50x95mm (x10)

JC478■
31-026397-00
PA459■
50-024870-00
(NBR)
JC152■ (x4)
31-026555-00
Ⓞ**JE117**
(31-023565-10)
→07/83
Ⓞ**JE160**
(31-024869-00)
08/83 →

HL457■ [79]
24-25753-01/0
(Cork)
HM5053■ [80]
24-28543-00/0
(ACM)

JJ140
(31-026554-10)

HR569■
24-30667-00/0

■ **NA5001** 32x47x10mm, FPM
(50-303185-50)
■ **NA5001**■ 32x47x10mm, FPM
(50-303185-50)
■ **NA5133**■ 85x105x11mm, FPM
(24-30727-87/0)

HL5020 [245]■
KA5020 [13]
NA5278 [54]

HBS268Ⓞ
(22-33031B)
M10x1.50x120mm (x10)

JD607■
50-028924-00
JD605■
31-028826-00
Ⓞ**JF205**
(31-025070-00)

HL732■
24-28815-00/0

HR397 [57]
34-000410-00
JH5117
(50-030046-00)

HR822■

■ **NA5124** (x2) 32x47x10mm, PTFE
(50-319433-00)
■ **NA5106**■ 35x48x10mm, PTFE
(50-319430-00)
■ **LK5008**■ [3] 85x131x15.7mm, PTFE
(50-319472-00)

HL5040 [245]■

HBS028Ⓞ
(22-39004B)
M11x1.50x147mm (x10)

JD281■
(31-027904-00)
JD282■ (x4)
(31-026880-00)
Ⓞ**JF205**
(31-025070-00)

HL606■
24-26237-01/0

JJ140
(31-026554-10)

HR816■ (x2)
24-30653-85/0

■ **NA5001** 32x47x10mm, FPM
(50-303185-50)
■ **NA5001**■ 32x47x10mm, FPM
(50-303185-50)
■ **NA5133**■ 85x105x11mm, FPM
(24-30727-87/0)

HL5020 [245]■



AY970



BM360



BZ910



JC152



JC478



JD281



JD282



JD5235



JD605



JD607



JE117



JE160



PA459



HL457



JP024



JJ140











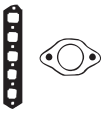

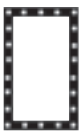

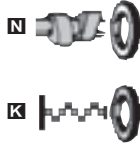

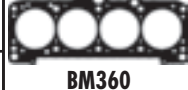

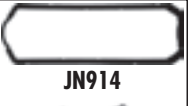











VW



KW/PS



Golf 1.8L GTI G60				04/90 → 07/91	76	BY630 (MLS)	DT819
Golf 1.8L GTI G60 Syncro				08/88 → 07/91		30-027516-00	21-27516-21/0
1H	1781	4	81.00	Digifant	118/160		
PG	1781	4	81.00		118/160		
Golf 1.8L T				08/97 → 06/05	77	AY970 (MLS)	CY971
Golf 1.8L T GTI				08/01 → 06/05		30-028495-00	21-28495-21/0
AGU	1781	4	81.00	Injection, DOHC	110/150		EY841 22-28897-02/0
ARZ	1781	4	81.00	SOHC	110/150		
AUM	1781	4	81.00	DOHC	110/150		
AUQ	1781	4	81.00	DOHC	132/180		
Golf Cabriolet 1.8L				08/89 → 03/93	78	BM360 (Fibre)	DM368
2H	1781	4	81.00	Digifant	72/98	30-026807-30	21-26807-20/0
Golf Cabriolet 1.8L				06/98 → 06/02	79	BZ910 (MLS)	DZ910
ADZ	1781	4	81.00	SOHC	66/89	30-027935-00	21-27935-20/0
ANP	1781	4	81.00		66/89		
Golf 1.9L D Diesel				11/91 → 04/99	80	BV850 (MLS), 1.53mm, 1 Hole	DV850▲
1Y	1896	4	79.50		47/50/ 64/68	30-028545-00	21-26557-20/0
						BV860 (MLS), 1.57mm, 2 Holes	→ Eng. 1Y 580 000
						30-028546-00	DV851▲
						BV870 (MLS), 1.61mm, 3 Holes	21-26557-21/0
						30-028547-00	Eng. 1Y 580 001 →
							ECO30 [8] 22-26384-04/0











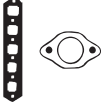

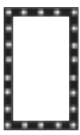

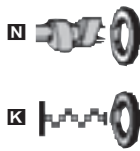



























								
HBS043 Ⓢ [22-39001B] M11x1.50x95mm (x10)	JC478 ■ 31-026397-00 PA459 ■ 50-024870-00 (NBR) JC152 ■ (x4) 31-026555-00	JN964 50-026423-10	JJ140 (31-026554-10)	HR569 ■ 24-30667-00/0	NA5001 32x47x10mm, FPM (50-303185-50) NA5001 ■ 32x47x10mm, FPM (50-303185-50) NA5133 ■ 85x105x11mm, FPM (24-30727-87/0)	HL5020 [245]■ NA5278 [54]	 AY970  BM360  BV850, BV860, BV870	 JN914  JN964  JP024  JH5023
HBS268 Ⓢ [22-33031B] M10x1.50x120mm (x10)	JD604 ■ (31-028824-00) JD605 ■ 31-028826-00	HL732 ■ 24-28815-00/0	HR397 [57] 34-000410-00 JH5117 (50-030046-00)	HR822 ■	NA5124 (x2) 32x47x10mm, PTFE (50-319433-00) NA5106 ■ 35x48x10mm, PTFE (50-319430-00) LK5003 ■ [3] 85x131x15.7mm, PTFE (50-319434-00)	HL5040 [245]■	 BY630  BZ910  JC152  JC478  JD170	 JJ140
HBS043 Ⓢ [22-39001B] M11x1.50x95mm (x10)	JC478 ■ 31-026397-00 PA459 ■ 50-024870-00 (NBR) JC152 ■ (x4) 31-026555-00  JE160 (31-024869-00)	HL457 ■ [79] 24-25753-01/0 (Cork) HM5053 ■ [80] 24-28543-00/0 (ACM)	JJ140 (31-026554-10)	HR569 ■ 24-30667-00/0	NA5001 32x47x10mm, FPM (50-303185-50) NA5001 ■ 32x47x10mm, FPM (50-303185-50) NA5133 ■ 85x105x11mm, FPM (24-30727-87/0)	HL5020 [245]■	 JC152  JC478  JD170	JJ140
HBS043 Ⓢ [22-39001B] M11x1.50x95mm (x10)	JD5235 ■ (31-028554-00) JC152 ■ (x4) 31-026555-00 ADZ JD600 ■ 31-028454-00 ANP  JE5076 (31-028373-00)	JP024 50-027505-00		HR816 ■ 24-30653-85/0	NA5001 32x47x10mm, FPM (50-303185-50) NA5001 ■ 32x47x10mm, FPM (50-303185-50) NA5133 ■ 85x105x11mm, FPM (24-30727-87/0) ADZ LK5006 ■ [3] 85x131x16mm, PTFE (50-319448-00) ANP	HL5020 [245]■	 JD5235  JD600  JD604  JD605	
HBS018 Ⓢ [22-39024B] M12x1.75x115mm (x10)	JD170 ■ 31-026556-10 JC152 ■ (x4) 31-026555-00  JE5076 (31-028373-00)	JN914 50-026557-10 HM5058 ■ 24-26557-00/0	JH5023 (31-029043-00)	HR569 ■ 24-30667-00/0 →Eng.1Y 580 000 HR816 ■ 24-30653-85/0 Eng.1Y 580 000 →	NA5001 32x47x10mm, FPM (50-303185-50) NA5001 ■ 32x47x10mm, FPM (50-303185-50) NA5133 ■ 85x105x11mm, FPM (24-30727-87/0) →Eng.1Y 800 000 LK5006 ■ [3] 85x131x16mm, PTFE (50-319448-00) Eng.1Y 800 001 →	HL5020 [245]■ NA5278 [54]	 JE160  PA459  HL457	



KW/PS



Golf 1.9L SDI Diesel		08/97 → 06/05			81	BZ010 (MLS), 1.45mm, 1 Hole 30-028910-10 →Eng.AGP 028 000 BZ020 (MLS), 1.53mm, 2 Holes 30-028911-10 →Eng.AGP 028 000 BZ030 (MLS), 1.61mm, 3 Holes 30-028912-10 →Eng.AGP 028 000 BZ040 (MLS), 1.47mm, 1 Hole 30-028915-10 Eng.AGP 028 001 → AQM BZ050 (MLS), 1.57mm, 2 Holes 30-028916-10 Eng.AGP 028 001 → AQM BZ060 (MLS), 1.67mm, 3 Holes 30-028917-10 Eng.AGP 028 001 → AQM	DZ010 ▲☒ 21-26556-20/0 AGP	ECO60 [8] 22-28897-00/0	
AGP	1896	4	79.50		50/68				
AQM	1896	4	79.50	SDi	50/68				
Golf 1.9L SDI Diesel		04/97 → 04/99			82	BX800 (MLS), 1.45mm, 1 Hole 30-028686-00 BX810 (MLS), 1.53mm, 2 Holes 30-028687-00 BX820 (MLS), 1.61mm, 3 Holes 30-028688-00	DX801 ▲ 21-27921-21/0	ECO30 [8] 22-26384-04/0	
AEY	1896	4	79.50	SDi	47/64				
Golf 1.9L TD Diesel		07/93 → 04/99			83	BV850 (MLS), 1.53mm, 1 Hole 30-028545-00 BV860 (MLS), 1.57mm, 2 Holes 30-028546-00 BV870 (MLS), 1.61mm, 3 Holes 30-028547-00	DV850 ▲ 21-26557-20/0 →Eng.AAZ-678 000 DV851 ▲ 21-26557-21/0 Eng.AAZ-678 001 →	ECO30 [8] 22-26384-04/0	
Golf 1.9L TD, GTD Diesel		11/91 → 08/97							AAZ
Golf 1.9L TDI Diesel		09/93 → 06/02			84	BX800 (MLS), 1.45mm, 1 Hole 30-028686-00 BX810 (MLS), 1.53mm, 2 Holes 30-028687-00 BX820 (MLS), 1.61mm, 3 Holes 30-028688-00	DX800 ▲ 21-27921-20/0 →Eng.IZ 720 000 AHU DX801 ▲ 21-27921-21/0 Eng.IZ 720 001 → ALE	ECO30 [8] 22-26384-04/0	
Golf 1.9L TDI Syncro Diesel		08/95 → 08/97							IZ
AHU/ALE	1896	4	79.50	SOHC	66/89				

								
HBS018 ® (22-39024B) M12x1.75x115mm (x10)	JD170 ■ 31-026556-10 JC152 ■ (x4) 31-026555-00 AGP JD600 ■ 31-028454-00 AQM  JE5076 (31-028373-00)		HR397 [57] 34-000410-00	HR816 ■ 24-30653-85/0	 NA5001 32x47x10mm, FPM (50-303185-50)  NA5106 ■ 35x48x10mm, PTFE (50-319430-00)  LK5003 ■ [3] 85x131x15.7mm, PTFE (50-319434-00)	NA5278 [54]	 BV850, BV860, BV870  BX800, BX810, BX820  BZ010, BZ020, BZ030  BZ040, BZ050, BZ060  JC152  JD170  JD600  JN914  JP003  JH5023  JJ140  JJ609	
HBS018 ® (22-39024B) M12x1.75x115mm (x10)	JD170 ■ 31-026556-10 JC152 ■ (x4) 31-026555-00  JE5076 (31-028373-00)	JP003 50-027921-00	JJ140 (31-026554-10)	HR816 ■ 24-30653-85/0	 NA5001 32x47x10mm, FPM (50-303185-50)  NA5001 ■ 32x47x10mm, FPM (50-303185-50)  NA5133 ■ 85x105x11mm, FPM (24-30727-87/0) →Eng.AEY 050 000  LK5006 ■ [3] 85x131x16mm, PTFE (50-319448-00) Eng.AEY 050 001→	HL5020 [245]■ NA5278 [54]	 JN914  JP003  JH5023  JJ140  JJ609	
HBS018 ® (22-39024B) M12x1.75x115mm (x10)	JD170 ■ 31-026556-10 JC152 ■ (x4) 31-026555-00	JN914 50-026557-10 HM5058 ■ 24-26557-00/0	JH5023 (31-029043-00)	HR569 ■ 24-30667-00/0 →Eng.AAZ-678 000 HR816 ■ 24-30653-85/0 Eng.AAZ-678 001→	 NA5001 32x47x10mm, FPM (50-303185-50)  NA5001 ■ 32x47x10mm, FPM (50-303185-50)  NA5133 ■ 85x105x11mm, FPM (24-30727-87/0)	HL5020 [245]■ NA5278 [54]	 JJ140  JJ609	
HBS018 ® (22-39024B) M12x1.75x115mm (x10)	JD170 ■ 31-026556-10 JC152 ■ (x4) 31-026555-00	JP003 50-027921-00	JJ609 (50-027500-00) (ACM)	HR569 ■ 24-30667-00/0 →Eng.IZ 720 000 AHU HR816 ■ 24-30653-85/0 Eng.IZ 720 001→ ALE	 NA5001 32x47x10mm, FPM (50-303185-50)  NA5001 ■ 32x47x10mm, FPM (50-303185-50)  NA5133 ■ 85x105x11mm, FPM (24-30727-87/0) →Eng.AHU 390 000 →Eng.ALE 576 0000 IZ  LK5006 ■ [3] 85x131x16mm, PTFE (50-319448-00) Eng.AHU 390 001→ Eng.ALE 576 001→	HL5020 [245]■ NA5278 [54]	 JJ609	



KW/PS



Golf 1.9L TDI Diesel		10/97 → 05/06		85		BZ010 (MLS), 1.45mm, 1 Hole		DZ010▲☒		ECO60 [8]	
Golf 1.9L TDI 4motion Diesel		07/98 → 04/02				30-028910-10		21-26556-20/0		22-28897-00/0	
AGR	1896	4	79.50	SOHC	66/89	→Eng.AGR 151 000					
ALH	1896	4	79.50		66/89	→Eng.ALH 085 000					
						BZ020 (MLS), 1.53mm, 2 Holes					
						30-028911-10					
						→Eng.AGR 151 000					
						→Eng.ALH 085 000					
						BZ030 (MLS), 1.61mm, 3 Holes					
						30-028912-10					
						→Eng.AGR 151 000					
						→Eng.ALH 085 000					
						BZ040 (MLS), 1.47mm, 1 Hole					
						30-028915-10					
						Eng.AGR 151 001 →					
						Eng.ALH 085 001 →					
						BZ050 (MLS), 1.57mm, 2 Holes					
						30-028916-10					
						Eng.AGR 151 001 →					
						Eng.ALH 085 001 →					
						BZ060 (MLS), 1.67mm, 3 Holes					
						30-028917-10					
						Eng.AGR 151 001 →					
						Eng.ALH 085 001 →					
Golf 1.9L TDI Diesel		08/97 → 05/04		86		BZ010 (MLS), 1.45mm, 1 Hole		DZ010▲☒		ECO60 [8]	
AHF	1896	4	79.50	SOHC	81/110	30-028910-10		21-26556-20/0		22-28897-00/0	
ASV	1896	4	79.50		81/110	→Eng.AHF 140 000					
						BZ020 (MLS), 1.53mm, 2 Holes					
						30-028911-10					
						→Eng.AHF 140 000					
						BZ030 (MLS), 1.61mm, 3 Holes					
						30-028912-10					
						→Eng.AHF 140 000					
						BZ040 (MLS), 1.47mm, 1 Hole					
						30-028915-10					
						Eng.AHF 140 001 →					
						ASV					
						BZ050 (MLS), 1.57mm, 2 Holes					
						30-028916-10					
						Eng.AHF 140 001 →					
						ASV					
						BZ060 (MLS), 1.67mm, 3 Holes					
						30-028917-10					
						Eng.AHF 140 001 →					
						ASV					
Golf 1.9L TDI Diesel		12/98 → 06/05		87		AF5381 (MLS), 1.49mm, 1 Hole		CC5231▲		EB5370 [8]	
Golf 1.9L TDI 4motion Diesel		05/99 → 06/05				30-030098-10		21-29463-20/0		22-29314-00/0	
ATD	1896	4	79.50		74/100	AF5391 (MLS), 1.57mm, 2 Holes					
AXR	1896	4	79.50	PDi, SOHC	74/100	30-030099-10					
AJM	1896	4	79.50	PDi	85/116	AF5401 (MLS), 1.65mm, 3 Holes					
AUY	1896	4	79.50	Direct Injection, SOHC	85/116	30-030100-10					
ASZ	1896	4	79.50	PDi, SOHC	96/131						
Golf 1.9L TDI Diesel		05/00 → 06/05		88		AF5381 (MLS), 1.49mm, 1 Hole		CC5231▲		EB5370 [8]	
Golf 1.9L TDI 4motion Diesel		02/00 → 06/05				30-030098-10		21-29463-20/0		22-29314-00/0	
ARL	1896	4	79.50	PDi	110/150	AF5391 (MLS), 1.57mm, 2 Holes					
						30-030099-10					
						AF5401 (MLS), 1.65mm, 3 Holes					
						30-030100-10					

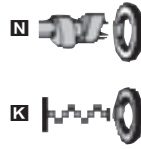
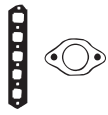

BZ010, BZ020,
BZ030



BZ040, BZ050,
BZ060



JC152



JD170



JD600



JD606

HBS018Ⓞ
(22-39024B)
M12x1.75x115mm (x10)

JD170■
31-026556-10
JC152■ (x4)
31-026555-00
JD606■
(31-028918-00)

HR397 [57]
34-000410-00

HR816■
24-30653-85/0

NA5001 32x47x10mm, FPM
(50-303185-50)
NB716■ 35x48x10mm, FPM
(50-306067-50)
LK5003■ [3] 85x131x15.7mm, PTFE
(50-319434-00)

NA5278 [54]

HBS018Ⓞ
(22-39024B)
M12x1.75x115mm (x10)

JD170■
31-026556-10
JC152■ (x4)
31-026555-00
AHF
JD600■
31-028454-00
ASV

HR397 [57]
34-000410-00

HR816■
24-30653-85/0

NA5001 32x47x10mm, FPM
(50-303185-50)
NB716■ 35x48x10mm, FPM
(50-306067-50)
LK5003■ [3] 85x131x15.7mm, PTFE
(50-319434-00)

NA5278 [54]

HBS300Ⓞ
(22-33034B)
M12x1.75x166mm (x10)

JD170■
31-026556-10
JC152■ (x4)
31-026555-00

JM5203
50-029934-00

HR397 [57]
34-000410-00

HR816■
24-30653-85/0

NA5124 32x47x10mm, PTFE
(50-319433-00)
NA5106■ 35x48x10mm, PTFE
(50-319430-00)
LK5003■ [3] 85x131x15.7mm, PTFE
(50-319434-00)

HL5034 [245]■

JD170■
31-026556-10
JC152■ (x4)
31-026555-00

JM5203
50-029934-00

HR397 [57]
34-000410-00

HR816■
24-30653-85/0

NA5124 32x47x10mm, PTFE
(50-319433-00)
NA5106■ 35x48x10mm, PTFE
(50-319430-00)
LK5003■ [3] 85x131x15.7mm, PTFE
(50-319434-00)







HL5034 [245]■

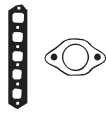

KW/PS

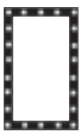

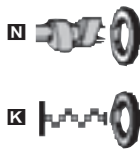
Golf 1.9L TDI Diesel					10/03 →	89	AF5381 (MLS), 1,49mm, 1 Hole	CC5230▲	EF5380
Golf 1.9L TDI 4motion Diesel					08/04 →		30-030098-10	21-29463-21/0	22-30369-00/0
BKC	1896	4	79.50	Direct Injection, SOHC	77/105	AF5391 (MLS), 1,57mm, 2 Holes	BKC, BXE		
BLS/BXE	1896	4	79.50		77/105	30-030099-10			
						AF5401 (MLS), 1,65mm, 3 Holes			
							30-030100-10		
Golf 1.9L TDI Diesel					05/04 →	90	AF5381 (MLS), 1,49mm, 1 Hole	CC5230▲ [273]	EF5380
BRU	1896	4	79.50	Direct Injection	66/89	30-030098-10	21-29463-21/0	22-30369-00/0	
BXF/BXJ	1896	4	79.50	Direct Injection, SOHC	66/90	AF5391 (MLS), 1,57mm, 2 Holes			
						30-030099-10			
						AF5401 (MLS), 1,65mm, 3 Holes			
						30-030100-10			
Golf 1.9L TDI Diesel					04/96 →04/99	91	BX800 (MLS), 1,45mm, 1 Hole	DX800▲	EC030 [8]
Golf Cabriolet 1.9L TDI Diesel					07/96 →05/98		30-028686-00	21-27921-20/0	22-26384-04/0
AFN	1896	4	79.50	SOHC	81/110	BX810 (MLS), 1,53mm, 2 Holes	→Eng.AFN 002 000		
						30-028687-00	DX801▲		
						BX820 (MLS), 1,61mm, 3 Holes	21-27921-21/0		
						30-028688-00	Eng.AFN 002 001 →		
Golf Cabriolet 1.9L TDI Diesel					06/98 →06/02	92	BX800 (MLS), 1,45mm, 1 Hole	DX800▲	EC030 [8]
AFN	1896	4	79.50	SOHC	81/110	30-028686-00	21-27921-20/0	22-26384-04/0	
AVG	1896	4	79.50		81/110	BX810 (MLS), 1,53mm, 2 Holes	→Eng.AFN 002 000		
						30-028687-00	DX801▲		
						BX820 (MLS), 1,61mm, 3 Holes	21-27921-21/0		
						30-028688-00	Eng.AFN 002 001 →		
							AVG		
Golf 2.0L TDI 4motion Mk V Diesel					08/04 →	93	AG9630 (MLS), 1,45mm, 1 Hole		EF5380
Golf 2.0L TDI Mk V Diesel					12/04 →		30-030349-00		22-30369-00/0
Golf 2.0L TDI Mk V Variant Diesel					06/07 →		AG9640 (MLS), 1,53mm, 2 Holes		
Golf 2.0L TDI Plus Mk V Diesel					12/05 →		AG9650 (MLS), 1,61mm, 3 Holes		
BMM	1968	4	81.00	Direct Injection, DOHC	103/140				
Golf 2.0L TDI 4motion MkV Variant Diesel					06/07 →	94	AG8970 (MLS), 1,55mm, 1 Hole		EF5380
Golf 2.0L TDI Mk V Variant Diesel					06/07 →		30-030249-00		22-30369-00/0
Golf 2.0L TDI Diesel					10/03 →		AG8800 (MLS), 1,63mm, 2 Holes		
Golf 2.0L TDI 16V Diesel					10/03 →		{30-030213-00}		
AZV	1968	4		PDI, SOHC	100/136	AG8960 (MLS), 1,71mm, 3 Holes			
BKD	1968	4	81.00		100/136	{30-030248-00}			
Golf 2.0L					07/98 →06/05	95	AB5370 (MLS)	CB5370■	EB5370 [8]
Golf 2.0L 4motion					10/00 →06/05		30-029314-00	21-29314-20/0	22-29314-00/0
APK	1984	4	82.50	SOHC	85/116		APK, AQY, AZH		
AQY/AZG/AZH/AZJ	1984	4	82.50		85/116				

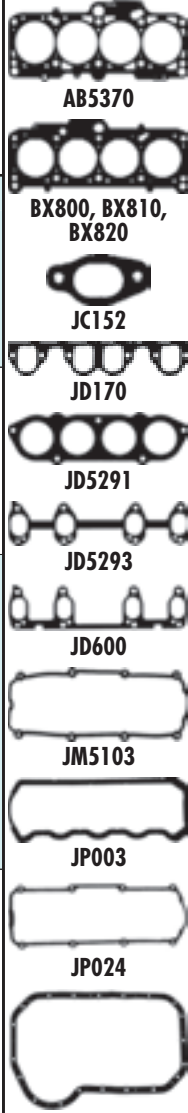









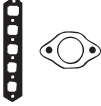

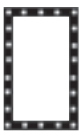

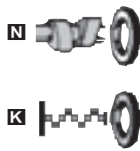







								
HBS300 ® (22-33034B) M12x1.75x166mm (x10) BKC, BLS	JD170 ■ 31-026556-10 JD600 ■ 31-028454-00 BKC, BXE	JM5203 50-029934-00 BKC, BXE	HR397 [57] 34-000410-00	HR816 ■ 24-30653-85/0	NA5124 32x47x10mm, PTFE (50-319433-00) NA5106 ■ 35x48x10mm, PTFE (50-319430-00) LK5012 ■ [3] [85] 85x132x15.7mm, ACM (50-319535-00)	HL5034 [245]■		AB5370 BX800, BX810, BX820 JC152 JD170 JD5291 JD5293 JD600 JM5103 JP003 JP024 JJ609
HBS300 ® (22-33034B) M12x1.75x166mm (x10)	JD170 ■ 31-026556-10 JD600 ■ 31-028454-00	JM5203 [273] 50-029934-00	HR397 [57] 34-000410-00	HR816 ■ 24-30653-85/0	NA5124 32x47x10mm, PTFE (50-319433-00) NA5106 ■ 35x48x10mm, PTFE (50-319430-00) LK5012 ■ [3] [85] 85x132x15.7mm, ACM (50-319535-00)	HL5034 [245]■		
HBS018 ® (22-39024B) M12x1.75x115mm (x10)	JD170 ■ 31-026556-10 JC152 ■ (x4) 31-026555-00 JE5076 (31-028373-00)	JP003 50-027921-00	JJ609 (50-027500-00) (ACM)	HR569 ■ 24-30667-00/0 →Eng.AFN 002 000 HR816 ■ 24-30653-85/0 Eng.AFN 002 001→	NA5001 32x47x10mm, FPM (50-303185-50) NA5001 ■ 32x47x10mm, FPM (50-303185-50) NA5133 ■ 85x105x11mm, FPM (24-30727-87/0) →Eng.AFN 576 000 LK5006 ■ [3] 85x131x16mm, PTFE (50-319448-00) Eng.AFN 576 000→	HL5020 [245]■		
HBS018 ® (22-39024B) M12x1.75x115mm (x10)	JD170 ■ 31-026556-10 JC152 ■ (x4) 31-026555-00	JP003 50-027921-00	JJ609 (50-027500-00) (ACM)	HR569 ■ 24-30667-00/0 →Eng.AFN 002 000 HR816 ■ 24-30653-85/0 Eng.AFN 002 001→ AVG	NA5001 32x47x10mm, FPM (50-303185-50) NA5001 ■ 32x47x10mm, FPM (50-303185-50) NA5133 ■ 85x105x11mm, FPM (24-30727-87/0) →Eng.AFN 576 000 LK5006 ■ [3] 85x131x16mm, PTFE (50-319448-00) Eng.AFN 576 000→ AVG	HL5020 [245]■		
HBS300 ® (22-33034B) M12x1.75x166mm (x10)	JD170 ■ 31-026556-10		HR397 [57] 34-000410-00	HR816 ■ 24-30653-85/0	NA5124 32x47x10mm, PTFE (50-319433-00) NA5106 ■ 35x48x10mm, PTFE (50-319430-00) LK5012 ■ [3] [85] 85x132x15.7mm, ACM (50-319535-00)			
HBS364 ® (22-39032B) M12x1.75x149mm (x10)	JD5805 ■ 50-030225-00 JD5806 ■ 31-030226-00 JD5815 ■ 31-030235-00	JM7031 50-030223-00 (Rubber)	HR397 [57] 34-000410-00	HR791 ■ 24-30614-76/0	NA5124 (x2) 32x47x10mm, PTFE (50-319433-00) NA5106 ■ 35x48x10mm, PTFE (50-319430-00) LK5012 ■ [3] [85] 85x132x15.7mm, ACM (50-319535-00)	HL5034 [245]■ KK5522 [86]		
HBS246 ® (22-33024B) M10x1.50x120mm (x10)	JD5291 ■ (31-029814-00) APK, AQY, AZG, AZH JD5340 ■ (x4) (50-029939-00) AZJ JD5293 ■ (31-029816-00)	JM5103 (50-029547-00) AZJ, AZG JP024 50-027505-00 APK, AQY, AZH	HR397 [57] 34-000410-00 JH5117 (50-030046-00) APK, AQY, AZH	HR816 ■ 24-30653-85/0	NA5124 32x47x10mm, PTFE (50-319433-00) NA5106 ■ 35x48x10mm, PTFE (50-319430-00) LK5003 ■ [3] 85x131x15.7mm, PTFE (50-319434-00)	HL5034 [245]■		



KW/PS



Golf 2.0L					11/91 → 04/99	96	BT810 (Fibre)	DT816	ES471
Golf Cabriolet 2.0L					07/93 → 05/98		30-027257-20	21-27257-24/0	2E (→09.1994)
2E	1984	4	82.50	Digifant	85/115	2E		21-27930-23/0	EB970
ADY	1984	4	82.50	OHV	85/116	BY750 (MLS)		10/94 →	22-27500-01/0
AGG	1984	4	82.50	SOHC	85/116	30-027930-00		ADY, AGG, AKR	
AKR	1984	4	82.50		85/116	ADY, AGG, AKR			
Golf 2.0L Bi-Fuel					02/02 →	97	AB5370 (MLS)		EB5370 [8]
BEH	1984	4	82.50		85/116	30-029314-00			22-29314-00/0
Golf 2.0L FSI					01/04 →	98	AG9600 (MLS)	CG9600	EG9600
AXW	1984	4	82.50	Injection	110/150	30-030352-00		21-30352-00/0	22-30370-00/0
BLR	1984	4	82.50	Injection, DOHC	110/150			AXW	
BLX	1984	4	82.50		110/150				
BLY/BVX/BVY/BVZ	1984	4	82.50	Injection, DOHC	110/150				
Golf 2.0L GTD Diesel					11/05 →	99	AG8970 (MLS), 1.55mm, 1 Hole		EF5380
BMN	1968	4	81.00	Direct Injection, DOHC	125/170	30-030249-00			22-30369-00/0
						AG8800 (MLS), 1.63mm, 2 Holes (30-030213-00)			
						AG8960 (MLS), 1.71mm, 3 Holes (30-030248-00)			
Golf 2.0L GTI 16V					08/92 → 08/97	100	BT810 (Fibre)	DT81B	EB970
ABF	1984	4	82.50	Digifant	110/150	30-027257-20		21-27930-20/0	22-27500-01/0
						→ Eng.ABF 031 251		Eng.ABF 031 252 →	
						BY750 (MLS)			
						30-027930-00			
						Eng.ABF 031 252 →			
Golf 2.0L SDI Diesel					01/04 →	101	AG8940 (MLS), 1.41mm, 1 Hole	CC5230	EF5380
BDK	1968	4	81.00	Direct Injection	55/75	30-030246-00		21-29463-21/0	22-30369-00/0
						AG8830 (MLS), 1.51mm, 2 Holes 30-030216-00			
						AG8950 (MLS), 1.61mm, 3 Holes (30-030247-00)			
Golf 2.3L V5					08/97 → 10/00	102	AG7800	CG7800	EG7800
Golf 2.3L V5 4motion					12/98 → 10/00				
AGZ	2324	5	81.00	DOHC, V5	110/150				
Golf 2.3L V5					10/00 → 06/05	103		CG9620	EG5010
AQN	2324	5	81.00	DOHC, V5	125/170			21-30348-00/0 (MLS)	
Golf 2.8L VR6 Mk IV					03/02 → 10/05	104	AG5000 (MLS)	CG5030	EG7800
BDF	2792	6	81.00	Injection, DOHC, V6	147/200	(30-030123-00)		21-30123-30/0	
Golf 2.8L V6					03/99 → 06/05	105	AG5000 (MLS)	CG5010	EG7800
AQP	2792	6	81.00	DOHC, V6	150/204	(30-030123-00)		21-30123-10/0	
AUE	2792	6	81.00	V6	150/204			AUE	
BDE	2792	6	81.00	DOHC, V6	150/204			CG5020	
								21-30123-20/0	
								AQP	
								CG5030	
								21-30123-30/0	
								BDE	











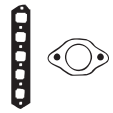

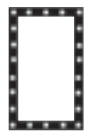

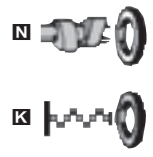



































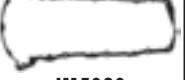









































































								
HBS028 Ⓞ (22-39004B) M11x1.50x147mm (x10) HBS043 Ⓞ (22-39001B) M11x1.50x95mm (x10)	JD483 ■ (31-027352-00) JC152 ■ (x4) 31-026555-00 Ⓞ JF205 (31-025070-00)	JP024 50-027505-00	JJ576 (50-027808-00) 2E (→09.1994) JJ609 (50-027500-00) (ACM) 10/94 → ADY, AGG, AKR	HR569 ■ 24-30667-00/0 2E HR816 ■ 24-30653-85/0 ADY, AGG, AKR	NA5001 32x47x10mm, FPM (50-303185-50) NA5001 ■ 32x47x10mm, FPM (50-303185-50) NA5133 ■ 85x105x11mm, FPM (24-30727-87/0) LK5006 ■ [3] 85x131x16mm, PTFE (50-319448-00)	HL5020 [245]■ NA5278 [54]	 AB5370  AG5000  BT810  BY750  JC152  JD170  JD281  JD282  JD483  JD5293  JD600  HL731  JM5103  JP024  JJ576  JJ609	
HBS246 Ⓞ (22-33024B) M10x1.50x120mm (x10)	JD5340 ■ (x4) (50-029939-00) JD5293 ■ (31-029816-00)	JM5103 (50-029547-00)	HR397 [57] 34-000410-00	HR816 ■ 24-30653-85/0	NA5124 32x47x10mm, PTFE (50-319433-00) NA5106 ■ 35x48x10mm, PTFE (50-319430-00) LK5003 ■ [3] 85x131x15.7mm, PTFE (50-319434-00)	HL5034 [245]■		
HBS363 Ⓞ (22-33038B) M10x1.50x122mm (x10)	JD5873 ■ 50-030353-00 (FPM) JD5813 ■ 31-030233-00	JM7048 50-030354-00 (Rubber/Metal) AXW	HR397 [57] 34-000410-00	HR791 ■ 24-30614-76/0	NA5124 32x47x10mm, PTFE (50-319433-00) NA5106 ■ 35x48x10mm, PTFE (50-319430-00) LK5008 ■ [3] 85x131x15.7mm, PTFE (50-319472-00)	HL5034 [245]■		
HBS364 Ⓞ (22-39032B) M12x1.75x149mm (x10)	JD5805 ■ 50-030225-00 JD5806 ■ 31-030226-00		HR397 [57] 34-000410-00	HR791 ■ 24-30614-76/0	NA5124 32x47x10mm, PTFE (50-319433-00) NA5106 ■ 35x48x10mm, PTFE (50-319430-00) LK5012 ■ [3] [85] 85x132x15.7mm, ACM (50-319535-00)	KK5522 [86]		
HBS028 Ⓞ (22-39004B) M11x1.50x147mm (x10) →Eng.ABF 031 251	JD281 ■ [✓] (31-027904-00) JD282 ■ (x4) (31-026880-00) Ⓞ JF205 (31-025070-00)	HL606 ■ 24-26237-01/0 →Eng.ABF 031 251 HL731 ■ 24-27937-00/0 Eng.ABF 031 252 →	JJ609 (50-027500-00) (ACM)	HR816 ■ (x2) 24-30653-85/0	NA5001 32x47x10mm, FPM (50-303185-50) NA5001 ■ 32x47x10mm, FPM (50-303185-50) NA5133 ■ 85x105x11mm, FPM (24-30727-87/0)	HL5020 [245]■		
HBS300 Ⓞ (22-33034B) M12x1.75x166mm (x10)	JD170 ■ 31-026556-10 JD600 ■ 31-028454-00	JM5203 50-029934-00	HR397 [57] 34-000410-00	HR816 ■ 24-30653-85/0	NA5124 32x47x10mm, PTFE (50-319433-00) NA5106 ■ 35x48x10mm, PTFE (50-319430-00) LK5012 ■ [3] [85] 85x132x15.7mm, ACM (50-319535-00)	HL5034 [245]■		
HBS461 (22-39034B)			HR397 [57] 34-000410-00		NA5106 ■ 35x48x10mm, PTFE (50-319430-00)			
		JM5234 (50-029982-00)	HR397 [57] 34-000410-00	HR822 ■	NA5106 ■ 35x48x10mm, PTFE (50-319430-00)			
	JD5857 ■ 50-030160-00 (Rubber)	JM7045 50-030133-00 (Rubber)	HR397 [57] 34-000410-00	HR5062 ■ 24-30614-73/0	NA5106 ■ 35x48x10mm, PTFE (50-319430-00)			
		JM7045 50-030133-00 (Rubber) BDE	HR397 [57] 34-000410-00	HR5062 ■ 24-30614-73/0	NA5106 ■ 35x48x10mm, PTFE (50-319430-00)			



KW/PS



Golf 2.8L VR6		01/92 → 08/97			106	AA5430 (Fibre)	CA5430	EC340
AAA	2792	6	81.00	Injection, DOHC, V6	128/174	30-027920-00	21-27920-20/0 →Eng.AAA 146 000	(22-28817-00/0) Eng.AAA 146 001 →
Golf 2.9L VR6		10/94 → 04/99			107	AA5430 (Fibre)	CA5430	EC340
Golf 2.9L VR6 Syncro		10/94 → 04/99				30-027920-00	21-27920-20/0 →Eng.ABV 023 000	(22-28817-00/0) Eng.ABV 023 001 →
ABV	2861	6	82.00	DOHC, V6	140/190			
Golf 3.2L Mk V		09/05 →			108	AG9610 (MLS)	CG9610	
Golf 3.2L R32 4motion Mk IV		09/02 → 06/05				30-030350-00	21-30350-00/0	
BFH	3189	6	84.00	V6	177/240			
BML	3189	6	84.00	Injection, DOHC, V6	177/241			
BUB	3189	6	84.00	DOHC, V6	184/250			
Iltis 1.6L TD Diesel		08/87 → 12/88			109	BN940 (Fibre), 1.53mm, 1 Hole	DD502▲ [83]	EG873
1C	1588	4	76.50	Indirect Injection	51/69	30-026230-30 BN950 (Fibre), 1.57mm, 2 Holes 30-026231-30 BN960 (Fibre), 1.61mm, 3 Holes 30-026232-30	(21-25753-27/0)	
Iltis 1.7L		03/79 → 12/88			110	BG870 (Fibre)	DG871	
WL	1714	4	79.50		55/75	30-024224-10	21-24224-24/0	
YX	1714	4	79.50	SOHC	55/75			
Jetta 1.3L		01/84 → 10/86			111	BL570 (Fibre), 1.73mm	DL570	EA900
GT	1272	4	75.00	SOHC	44/60	30-024813-20	21-24813-24/0	(22-26516-00/0)
Jetta 1.3L		01/84 → 06/87			112	BL570 (Fibre), 1.73mm	DL570	EA900
HK	1272	4	75.00		40/54	30-024813-20	21-24813-24/0	(22-26516-00/0)
MH	1272	4	75.00	SOHC	40/54		HK DL572 21-24813-25/0 MH	HK EV460 22-26516-01/0 MH
Jetta 1.3L		06/87 → 12/91			113	BL570 (Fibre), 1.73mm	DL572	EV460
2G/MH	1272	4	75.00	SOHC	40/54	30-024813-20	21-24813-25/0	22-26516-01/0
NZ	1272	4	75.00		40/54		MH DL574 21-24813-27/0 NZ, 2G	











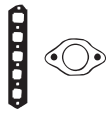

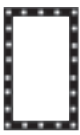

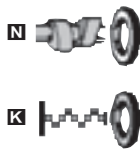





















								
HBS077 ⊕ (22-39012B) M11x1.50x85mm (x7) M11x1.50x144mm (x3) M11x1.50x119mm (x10)	JD5232   (31-027918-00) JA5068   (31-027917-00) JA5069  [28] (31-027913-00) JD5109  [29] (31-027914-00)	JM5030 50-027915-00 →Eng.AAA 146 000 JM5099 50-029103-00 Eng.AAA 146 001→	JH5013 (31-027911-00) →Eng.AAA 146 000 JH5059 (50-028817-00) Eng.AAA 146 000→	HR602  24-30670-61/0	NA5133  35x48x10mm, FPM (50-306067-50) NA5133  85x105x11mm, FPM (24-30727-87/0)			 AA5430  BG870  BL570  BN940, BN950, BN960  JA5068  JC152  JC243  JC259  JC478  JD246  JD5109  JD5232  JE154  JE904  HL456
HBS077 ⊕ (22-39012B) M11x1.50x85mm (x7) M11x1.50x144mm (x3) M11x1.50x119mm (x10)	JD5232   (31-027918-00) JA5068   (31-027917-00) JA5069  [28] (31-027913-00) JD5109  [29] (31-027914-00)	JM5030 50-027915-00 →Eng.ABV 023 000 JM5099 50-029103-00 Eng.ABV 023 001→	JH5013 (31-027911-00) →Eng.ABV 023 000 JH5059 (50-028817-00) Eng.ABV 023 001→	HR602  24-30670-61/0	NA5133  35x48x10mm, FPM (50-306067-50) NA5133  85x105x11mm, FPM (24-30727-87/0)			 HL457  JM154  JM5030  JM5099  JN641  JH5013  JH5059  KA5020
HBS466 (22-33039B)	JD5874  50-030351-00 (FPM)	JM7045 50-030133-00 (Rubber)	HR397 [57] 34-000410-00	HR5062  24-30614-73/0	NA5106  35x48x10mm, PTFE (50-319430-00)			 JA5069  JC152  JC243  JC259  JC478  JD246  JD5109  JD5232  JE154  JE904  HL456
HBS018 ⊕ (22-39024B) M12x1.75x115mm (x10)	JC243  (31-026727-00) JC152  (x4) 31-026555-00	HL457  [79] 24-25753-01/0 (Cork) HM5053  [80] 24-28543-00/0 (ACM)	JJ140 (31-026554-10)	HR569  24-30667-00/0	NA5001  32x47x10mm, FPM (50-303185-50) NA5001  32x47x10mm, FPM (50-303185-50) NA5133  85x105x11mm, FPM (24-30727-87/0)	HL5020 [245]  KA5020 [13]		 JC152  JC243  JC259  JC478  JD246  JD5109  JD5232  JE154  JE904  HL456
HBS043 ⊕ (22-39001B) M11x1.50x95mm (x10)	JC478  31-026397-00 JC152  (x4) 31-026555-00  JE904 (31-023715-00)	HL456  [82] (24-23835-00/0) (Cork)		HR569  24-30667-00/0	NA5001  32x47x10mm, FPM (50-303185-50) NA5001  32x47x10mm, FPM (50-303185-50) NA5133  85x105x11mm, FPM (24-30727-87/0)	HL5020 [245] 		 JC259  JC478  JD246  JD5109  JD5232  JE154  JE904  HL456
HBS043 ⊕ (22-39001B) M11x1.50x95mm (x10)	JD246  (31-026474-20) JC259  (x2) 31-026229-10  JE154	JM154 31-024942-10 JN641 50-025265-10 MH	JJ183 (31-026516-10)	HR569  24-30667-00/0	NA5001  32x47x10mm, FPM (50-303185-50) NA5001  32x47x10mm, FPM (50-303185-50) NA5133  85x105x11mm, FPM (24-30727-87/0)	HL5020 [245] 		 JC259  JC478  JD246  JD5109  JD5232  JE154  JE904  HL456
HBS043 ⊕ (22-39001B) M11x1.50x95mm (x10)	JD246  (31-026474-20) JC259  (x2) 31-026229-10	JN641 50-025265-10	JJ183 (31-026516-10)	HR569  24-30667-00/0 MH HR816  24-30653-85/0 NZ, 2G	NA5001  32x47x10mm, FPM (50-303185-50) NA5001  32x47x10mm, FPM (50-303185-50) NA5133  85x105x11mm, FPM (24-30727-87/0)	HL5020 [245] 		 JC259  JC478  JD246  JD5109  JD5232



KW/PS



Jetta 1.6L				03/86 → 10/91		114	BM360 (Fibre)	DM368	EG873
PN	1595	4	81.00			51/70	30-026807-30	21-26807-20/0	
RF	1595	4	81.00			53/72			
Jetta 1.6L				01/84 → 07/92		115	BM360 (Fibre)	DM366	EG873
ABN/EZ	1595	4	81.00			55/75	30-026807-30	21-26807-26/0	
HM	1595	4	81.00	SOHC		55/75		ABN DM368 21-26807-20/0 EZ, HM	
Jetta 1.6L				10/05 →		116	AC5220 (MLS)	CC5222	
BSE/BSF	1595	4	81.00	SOHC		75/102	30-029462-00	21-29462-22/0	
Jetta 1.6L D Diesel				01/84 → 10/91		117	BN080 (Fibre), 1.40mm, 1 Notch	DD501▲ [83]	EG873
JP/ME	1588	4	76.50			40/54	30-024901-30 →07/85	21-25753-26/0	
							BN090 (Fibre), 1.50mm, 2 Notches 30-024849-30 →07/85		
							BN100 (Fibre), 1.60mm, 3 Notches 30-024850-30 →07/85		
							BN940 (Fibre), 1.53mm, 1 Hole 30-026230-30 08/85→		
							BN950 (Fibre), 1.57mm, 2 Holes 30-026231-30 08/85→		
							BN960 (Fibre), 1.61mm, 3 Holes 30-026232-30 08/85→		
Jetta 1.6L FSI				09/05 →		118	AG8850 (MLS)	CG8850	
BLF	1598	4	76.50	Injection, DOHC		85/115	30-030218-00	21-30218-00/0	











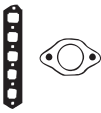

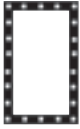

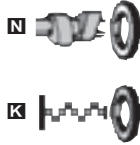





































































































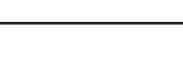



								
HBS043 Ⓞ [22-39001B] M11x1.50x95mm (x10)	JC478 ■ 31-026397-00 PA459 ■ 50-024870-00 (NBR) JC152 ■ (x4) 31-026555-00  [31-024869-00]	HL457 ■ [79] 24-25753-01/0 (Cork) HM5053 ■ [80] 24-28543-00/0 (ACM)	JJ140 [31-026554-10]	HR569 ■ 24-30667-00/0	NA5001 32x47x10mm, FPM [50-303185-50] NA5001 ■ 32x47x10mm, FPM [50-303185-50] NA5133 ■ 85x105x11mm, FPM [24-30727-87/0]	HL5020 [245]■ KA5020 [13]	 AC5220  BM360  BN080, BN090, BN100  BN940, BN950, BN960  JC152  JC478  JD5293  JE160  PA459  HL457  JJ140	
HBS043 Ⓞ [22-39001B] M11x1.50x95mm (x10)	JC478 ■ 31-026397-00 PA459 ■ 50-024870-00 (NBR) JC152 ■ (x4) 31-026555-00  [31-024869-00]	HL457 ■ [79] 24-25753-01/0 (Cork) HM5053 ■ [80] 24-28543-00/0 (ACM)	JJ140 [31-026554-10]	HR569 ■ 24-30667-00/0	NA5001 32x47x10mm, FPM [50-303185-50] NA5001 ■ 32x47x10mm, FPM [50-303185-50] NA5133 ■ 85x105x11mm, FPM [24-30727-87/0]	HL5020 [245]■ KA5020 [13]	 JC152  JC478  JD5293  JE160  PA459  HL457  JJ140	
HBS246 Ⓞ [22-33024B] M10x1.50x120mm (x10)	JD5340 ■ (x4) [50-029939-00] JD5293 ■ [31-029816-00]	JM5205 50-029938-00 (Rubber)	HR397 [57] 34-000410-00	HR817 ■ 24-30614-78/0	NA5124 32x47x10mm, PTFE [50-319433-00] NA5106 ■ 35x48x10mm, PTFE [50-319430-00]	HL5034 [245]■	 JE160  PA459  HL457  JJ140	
HBS018 Ⓞ [22-33024B] M12x1.75x115mm (x10)	JC478 ■ 31-026397-00 JC152 ■ (x4) 31-026555-00	HL457 ■ [79] 24-25753-01/0 (Cork) HM5053 ■ [80] 24-28543-00/0 (ACM)	JJ140 [31-026554-10]	HR569 ■ 24-30667-00/0	NA5001 32x47x10mm, FPM [50-303185-50] NA5001 ■ 32x47x10mm, FPM [50-303185-50] NA5133 ■ 85x105x11mm, FPM [24-30727-87/0]	HL5020 [245]■ KA5020 [13]	 JC152  JC478  JD5293  JE160  PA459  HL457  JJ140	
HBS249 Ⓞ [22-33025B] M9x1.25x138mm (x10)	JD5809 ■ 31-030229-00 JD5814 ■ 31-030234-00	HR397 [57] 34-000410-00	HR397 [57] 34-000410-00	HR791 ■ 24-30614-76/0	NA5106 ■ 35x48x10mm, PTFE [50-319430-00] LK5011 ■ [3] [78] 85x131x15.94mm, PTFE →07/05 LK5013 ■ [3] [118] 85x111x15.5mm 08/05→			



KWPS



Jetta 1.6L TD Diesel				01/84 → 10/91		119	BN080 (Fibre), 1.40mm, 1 Notch 30-024901-30 →07/85 BN090 (Fibre), 1.50mm, 2 Notches 30-024849-30 →07/85 BN100 (Fibre), 1.60mm, 3 Notches 30-024850-30 →07/85 BN940 (Fibre), 1.53mm, 1 Hole 30-026230-30 08/85→ BN950 (Fibre), 1.57mm, 2 Holes 30-026231-30 08/85→ BN960 (Fibre), 1.61mm, 3 Holes 30-026232-30 08/85→		DD502▲ [83] (21-25753-27/0)	EG873
JR/MF	1588	4	76.50		51/70					
Jetta 1.6L TD Diesel				04/89 → 10/91		120	BN940 (Fibre), 1.53mm, 1 Hole 30-026230-30 BN950 (Fibre), 1.57mm, 2 Holes 30-026231-30 BN960 (Fibre), 1.61mm, 3 Holes 30-026232-30		DD502▲ [83] (21-25753-27/0)	EG873
1V	1588	4	76.50		44/60					
RA/SB	1588	4	76.50		59/80					
Jetta 1.8L				01/84 → 10/91		121	BM360 (Fibre) 30-026807-30		DM368 21-26807-20/0	EG873
Jetta 1.8L Syncro				08/87 → 07/91						
Jetta 1.8L Syncro Mk II				08/87 → 07/88						
RH	1781	4	81.00		62/84					
GU/GX/GZ/HV/RP	1781	4	81.00		66/89					
1P	1781	4	81.00	SOHC	72/98					
PF	1781	4	81.00	Digifant	79/107					
RD	1781	4	81.00		79/107					
EV	1781	4	81.00		82/111					
PB	1781	4	81.00	Digifant	82/111					
Jetta 1.8L 16V				08/86 → 10/91		122	BM360 (Fibre) 30-026807-30		DM365 21-26807-21/0	ET811 (22-26554-40/0)
PL	1781	4	81.00	K-Jetronic	95/129					
KR	1781	4	81.00	K-Jetronic	98/133					
Jetta 1.9L TDI Diesel				09/05 →		123	AF5381 (MLS), 1.49mm, 1 Hole 30-030098-10 AF5391 (MLS), 1.57mm, 2 Holes 30-030099-10 AF5401 (MLS), 1.65mm, 3 Holes 30-030100-10		CC5230▲ 21-29463-21/0 BKC, BXE	EF5380 22-30369-00/0
BKC	1896	4	79.50		77/105					
BLS/BXE	1896	4	79.50	Direct Injection, SOHC	77/105					
Jetta 2.0L TDI Mk III Diesel				10/05 →		124	AG9630 (MLS), 1.45mm, 1 Hole 30-030349-00 AG9640 (MLS), 1.53mm, 2 Holes AG9650 (MLS), 1.61mm, 3 Holes			EF5380 22-30369-00/0
BMM	1968	4	81.00	Direct Injection, DOHC	103/140					
Jetta 2.0L FSI				08/05 →		125	AG9600 (MLS) 30-030352-00			EG9600 22-30370-00/0
BLR/BLY/BVY/BVZ	1984	4	82.50	Injection, DOHC	110/150					











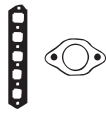

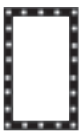

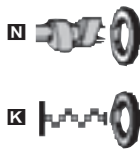





								
HBS018  (22-39024B) M12x1.75x115mm (x10)	JC243  (31-026727-00) JC152  (x4) 31-026555-00  JE160 (31-024869-00)	HL457  [79] 24-25753-01/0 (Cork) HM5053  [80] 24-28543-00/0 (ACM)	JJ140 (31-026554-10)	HR569  24-30667-00/0	 NA5001 32x47x10mm, FPM (50-303185-50)  NA5001 32x47x10mm, FPM (50-303185-50)  NA5133 85x105x11mm, FPM (24-30727-87/0)	HL5020 [245]  KA5020 [13] NA5278 [54]	 BM360  BN980, BN990, BN100  BN940, BN950, BN960  JC152  JC243  JC478  JD170  JD281  JD282  JD600  JE160  PA459  HL457  JJ140	
HBS018  (22-39024B) M12x1.75x115mm (x10)	JC243  (31-026727-00) JC152  (x4) 31-026555-00	HL457  [79] 24-25753-01/0 (Cork) HM5053  [80] 24-28543-00/0 (ACM)	JJ140 (31-026554-10)	HR569  24-30667-00/0	 NA5001 32x47x10mm, FPM (50-303185-50)  NA5001 32x47x10mm, FPM (50-303185-50)  NA5133 85x105x11mm, FPM (24-30727-87/0)	HL5020 [245]  KA5020 [13] NA5278 [54]	 JD281  JD282  JD600  JE160  PA459  HL457  JJ140	
HBS043  (22-39001B) M11x1.50x95mm (x10)	JC478  31-026397-00 PA459  50-024870-00 (NBR) JC152  (x4) 31-026555-00  JE160 (31-024869-00)  JF205 (31-025070-00)	HL457  [79] 24-25753-01/0 (Cork) HM5053  [80] 24-28543-00/0 (ACM)	JJ140 (31-026554-10)	HR569  24-30667-00/0	 NA5001 32x47x10mm, FPM (50-303185-50)  NA5001 32x47x10mm, FPM (50-303185-50)  NA5133 85x105x11mm, FPM (24-30727-87/0)	HL5020 [245]  KA5020 [13] NA5278 [54]	 JD600  JE160  PA459  HL457  JJ140	
HBS028  (22-39004B) M11x1.50x147mm (x10)	JD281  (31-027904-00) JD282  (x4) (31-026880-00)  JF205 (31-025070-00)	HL606  24-26237-01/0	JJ140 (31-026554-10)	HR816  (x2) 24-30653-85/0	 NA5001 32x47x10mm, FPM (50-303185-50)  NA5001 32x47x10mm, FPM (50-303185-50)  NA5133 85x105x11mm, FPM (24-30727-87/0)	HL5020 [245] 	 JD281  JD282  JD600  JE160  PA459  HL457  JJ140	
HBS300  (22-33034B) M12x1.75x166mm (x10) BKC, BLS	JD170  31-026556-10 JD600  31-028454-00 BKC, BXE	JM5203 50-029934-00 BKC, BXE	HR397 [57] 34-000410-00	HR816  24-30653-85/0	 NA5124 32x47x10mm, PTFE (50-319433-00)  NA5106 35x48x10mm, PTFE (50-319430-00)  LK5012 [3] [85] 85x132x15.7mm, ACM (50-319535-00)	HL5034 [245] 	 JD170  JD600  JE160  PA459  HL457  JJ140	
HBS300  (22-33034B) M12x1.75x166mm (x10)	JD170  31-026556-10		HR397 [57] 34-000410-00	HR816  24-30653-85/0	 NA5124 32x47x10mm, PTFE (50-319433-00)  NA5106 35x48x10mm, PTFE (50-319430-00)  LK5012 [3] [85] 85x132x15.7mm, ACM (50-319535-00)		 JD170  JD600  JE160  PA459  HL457  JJ140	
HBS363  (22-33038B) M10x1.50x122mm (x10)	JD5873  50-030353-00 (FPM) JD5813  31-030233-00		HR397 [57] 34-000410-00	HR791  24-30614-76/0	 NA5124 32x47x10mm, PTFE (50-319433-00)  NA5106 35x48x10mm, PTFE (50-319430-00)  LK5008 [3] 85x131x15.7mm, PTFE (50-319472-00)	HL5034 [245] 	 JD170  JD600  JE160  PA459  HL457 JJ140	

VW

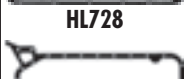

KW/PS



								
HBS364 Ⓢ (22-39032B) M12x1.75x149mm (x10)	JD5805 ■ 50-030225-00 JD5806 ■ 31-030226-00 JD5815 ■ 31-030235-00	JM7031 50-030223-00 (Rubber)	HR397 [57] 34-000410-00	HR791 ■ 24-30614-76/0	NA5124 (x2) 32x47x10mm, PTFE (50-319433-00) NA5106 ■ 35x48x10mm, PTFE (50-319430-00) LK5012 ■ [3] [85] 85x132x15.7mm, ACM (50-319535-00)	HL5034 [245] ■ KK5522 [86]		 AF5310  AF5320  AF5330  BG940  BW680, BW690, BW700  BZ900  JC146  JC152  JD160  JD312  HL469  HL728  JJ499  JJ501
HBS364 Ⓢ (22-39032B) M12x1.75x149mm (x10)	JD5805 ■ 50-030225-00 JD5806 ■ 31-030226-00		HR397 [57] 34-000410-00	HR791 ■ 24-30614-76/0	NA5124 32x47x10mm, PTFE (50-319433-00) NA5106 ■ 35x48x10mm, PTFE (50-319430-00) LK5012 ■ [3] [85] 85x132x15.7mm, ACM (50-319535-00)	KK5522 [86]		
HBS150 Ⓢ (22-26009B) M12x1.75x102mm (x10)	JD160 ■ (31-027310-00)	HM5057 ■ 24-27307-50/0	JJ499 (31-027311-00)	HR5055 ■ 24-30704-45/0	NB973 ■ 45x67x8mm, FPM (50-305910-50) NB974 ■ 93x114x13mm, FPM (50-319192-00)			
HBS021 Ⓢ (22-39003B) M12x1.75x115mm (x12)	JD312 ■ 31-027043-00 JC152 ■ (x5) 31-026555-00		JJ501 (31-027042-00)	HR615 ■ 24-30667-05/0	NA5001 (x2) 32x47x10mm, FPM (50-303185-50) NB716 ■ 35x48x10mm, FPM (50-306067-50) NA5133 ■ 85x105x11mm, FPM (24-30727-87/0) →Eng.AGX 009 000 LK5006 ■ [3] 85x131x16mm, PTFE (50-319448-00) Eng.AGX 009 001 →			
HBS021 Ⓢ (22-39003B) M12x1.75x115mm (x12)	JD312 ■ 31-027043-00 JC152 ■ (x5) 31-026555-00			HR615 ■ 24-30667-05/0	NA5001 (x2) 32x47x10mm, FPM (50-303185-50) NB716 ■ 35x48x10mm, FPM (50-306067-50) LK5006 ■ [3] 85x131x16mm, PTFE (50-319448-00)	NA5278 [54]		
HBS021 Ⓢ (22-39003B) M12x1.75x115mm (x12)	JD312 ■ 31-027043-00 JC152 ■ (x5) 31-026555-00		JJ501 (31-027042-00)	HR615 ■ 24-30667-05/0	NA5001 (x2) 32x47x10mm, FPM (50-303185-50) NB716 ■ 35x48x10mm, FPM (50-306067-50) NA5133 ■ 85x105x11mm, FPM (24-30727-87/0) →Eng.AHD 036 065 LK5006 ■ [3] 85x131x16mm, PTFE (50-319448-00) Eng.AHD 036 066 →	NA5278 [54]		
HBS022 Ⓢ (22-39005B) M12x1.75x115mm (x14)	JC146 ■ 31-024044-20 JC152 ■ (x6) 31-026555-00 Ⓢ JE138 [29] (31-024515-00)	JN849 (31-024861-10)		HR805 ■	NA5001 (x2) 32x47x10mm, FPM (50-303185-50) NB716 ■ 35x48x10mm, FPM (50-306067-50) NA5133 ■ 85x105x11mm, FPM (24-30727-87/0)	NA5278 [54]		
HBS022 Ⓢ (22-39005B) M12x1.75x115mm (x14) Ch.28-P-014 817 →	JC146 ■ 31-024044-20 JC152 ■ (x6) 31-026555-00 Ⓢ JE138 [29] (31-024515-00)	HL728 50-027932-00 Ch.28-P-014 817 → HL469 ■ 24-24042-00/0 →Ch.28-P-014 816		HR805 ■ (x12)	NA5001 ■ (x2) 32x47x10mm, FPM (50-303185-50) NB716 ■ 35x48x10mm, FPM (50-306067-50) NA5133 ■ 85x105x11mm, FPM (24-30727-87/0)	NA5278 [54]		



KW/PS



LT 28-55 2.4L D Diesel				08/89 → 06/96		134		DM660▲	EX980
1S	2383	6	76.50	Indirect Injection, SOHC	51/70	BW680 (Fibre), 1.53mm, 1 Notch →Eng.ACT 011 319	21-26537-21/0	22-27422-00/0	
ACT	2384	6	76.50	SOHC	51/70	1S BW690 (Fibre), 1.57mm, 2 Notches 30-027337-10 →Eng.ACT 011 319	1S	1S	
						1S BW700 (Fibre), 1.61mm, 3 Notches →Eng.ACT 011 319			
						1S BZ930 (MLS), 1.57mm, 2 Holes 30-028809-00 Eng.ACT 011 320 →			
LT 28-55 2.4L TD Diesel				06/92 → 06/96		135			
ACL	2384	6	76.50		70/95	BW680 (Fibre), 1.53mm, 1 Notch →Eng.ACL 041 031			
						BW690 (Fibre), 1.57mm, 2 Notches 30-027337-10 →Eng.ACL 041 031			
						BW700 (Fibre), 1.61mm, 3 Notches →Eng.ACL 041 031			
						BZ930 (MLS), 1.57mm, 2 Holes 30-028809-00 Eng.ACL 041 032 →			
LT 28-55 2.4L TD Diesel				12/82 → 09/93		136			
LT 28-55 2.4L TD 4WD Diesel				08/78 → 03/86					
1G	2383	6	76.50		68/92	BW680 (Fibre), 1.53mm, 1 Notch	DM660▲	EX980	
DV	2383	6	76.50		75/80/ 102/ 109	BW690 (Fibre), 1.57mm, 2 Notches 30-027337-10	21-26537-21/0	22-27422-00/0	
						BW700 (Fibre), 1.61mm, 3 Notches			
LT 40-55 2.4L D 4WD Diesel				01/79 → 03/86		137			
DW	2383	6	76.50		55/57/ 75/78	BW680 (Fibre), 1.53mm, 1 Notch	DM660▲	EX980	
						BW690 (Fibre), 1.57mm, 2 Notches 30-027337-10	21-26537-21/0	22-27422-00/0	
						BW700 (Fibre), 1.61mm, 3 Notches			
Lupo 1.0L				09/98 → 07/05		138			
AER	999	4	67.10	Injection, SOHC	37/50	AD5630 (MLS), 0.50mm 30-029660-00	CA5410	EB961 [8]	
AHT	999	4	67.10	OHV	37/50	ALD/ANV/AUC	21-29052-20/0	22-28897-03/0	
ALD	999	4	67.10	Motronic, SOHC	37/50	AA5410 (MLS), 0.60mm	AER/ALL	AER	
ALL	999	4	67.10	Injection, SOHC	37/50	30-029052-10	CD5630		
ANV	999	4	67.10	Motronic, SOHC	37/50	AER/ALL	21-29660-00/0		
AUC	999	4	67.10		37/50		ALD/ANV/AUC		

HBS022 ⊕ [22-39005B] M12x1.75x115mm (x14)	JC146 ■ 31-024044-20 JC152 ■ (x6) 31-026555-00 JE138 [29] (31-024515-00)	HL728 50-027932-00		HR805 ■	NA5001 (x2) 32x47x10mm, FPM (50-303185-50) NB716 ■ 35x48x10mm, FPM (50-306067-50) NA5133 ■ 85x105x11mm, FPM (24-30727-87/0)	 AA5410 AD5630 BW680, BW690, BW700 BZ930 JC146 JC152 JD5318 JD597 JD601 HL728 JP074
HBS022 ⊕ [22-39005B] M12x1.75x115mm (x14)	JC146 ■ 31-024044-20 JC152 ■ (x6) 31-026555-00	HL728 50-027932-00		HR805 ■	NA5001 (x2) 32x47x10mm, FPM (50-303185-50) NB716 ■ 35x48x10mm, FPM (50-306067-50) NA5133 ■ 85x105x11mm, FPM (24-30727-87/0)	
HBS022 ⊕ [22-39005B] M12x1.75x115mm (x14)	JC146 ■ 31-024044-20 JC152 ■ (x6) 31-026555-00	HL728 50-027932-00		HR805 ■	NA5001 (x2) 32x47x10mm, FPM (50-303185-50) NB716 ■ 35x48x10mm, FPM (50-306067-50) NA5133 ■ 85x105x11mm, FPM (24-30727-87/0)	NA5278 [54]
HBS022 ⊕ [22-39005B] M12x1.75x115mm (x14)	JC146 ■ 31-024044-20 JC152 ■ (x6) 31-026555-00	HL728 50-027932-00		HR805 ■ (x12)	NA5001 ■ (x2) 32x47x10mm, FPM (50-303185-50) NB716 ■ 35x48x10mm, FPM (50-306067-50) NA5133 ■ 85x105x11mm, FPM (24-30727-87/0)	
HBS249 ⊕ [22-33025B] M9x1.25x138mm (x10) AER, ALL HBS362 ⊕ [22-39031B] M9x1.25x162mm (x10) AUC/ALD/ANV	JD597 ■ ■ 50-350355-00 AER ALD ALL ANV AUC JD5318 ■ (31-029901-00) ALD, ANV, AUC JD601 ■ 31-028644-00 AER, ALL JD5818 ■ ■ 31-030238-00 (MLS) AHT JD5817 ■ 31-030237-00 (MLS) AHT JD5849 ■ ■ 31-030259-00 (MLS) AHT JE5076 (31-028373-00)	JM5285 (50-026659-00) AHT JP074 50-027907-00 AER, ALL	HR397 [57] 34-000410-00 AER ALD ALL ANV AUC	HR816 ■ 24-30653-85/0 AER, AHT, ALL HR817 ■ 24-30614-78/0 ALD, ANV, AUC	NA5001 32x47x10mm, FPM (50-303185-50) AER, ALL NA5185 32x42x6mm, FPM (50-319489-00) ALD, ANV, AUC NA5001 ■ 32x47x10mm, FPM (50-303185-50) →Eng.AER 220 083 LK5011 ■ [3] [78] 85x131x15.94mm, PTFE ALD, ANV, AUC NA5133 ■ 85x105x11mm, FPM (24-30727-87/0) →Eng.AER 220 083 NA5185 ■ 32x42x6mm, FPM (50-319489-00) Eng.AER 220 084 → ALL, ALD, ANV, AUC LK5006 ■ [3] 85x131x16mm, PTFE (50-319448-00) Eng.AER 220 084 → ALL	HL5020 [245]■



KW/PS



Lupo 1.2L TDI 3L Diesel				07/99 → 07/05	139	AC5190 (MLS), 1.45mm, 1 Hole 30-029459-00 AC5200 (MLS), 1.53mm, 2 Holes 30-029460-00 AC5210 (MLS), 1.61mm, 3 Holes [30-029461-00]	CC5190▲☒ (21-29459-20/0)	ED5650 [8] (22-29671-00/0)
ANY	1191	3	76.50	PDi, SOHC	45/61			
AYZ	1191	3	76.50	SOHC	45/61			
Lupo 1.4L				10/00 → 07/05	140	AD5640 (MLS), 0.64mm 30-029662-00	CD5640☒ 21-29662-20/0	
AUD	1390	4	76.50	SOHC	44/60			
Lupo 1.4L 16V				09/98 → 07/05	141	AB5701 (MLS) 30-029313-10	CB5700☒ 21-29313-20/0	EB5700 [8] 22-29313-00/0
AHW/AKQ	1390	4	76.50		55/75			
APE	1390	4	76.50	MPi, DOHC	55/75			
AUA	1390	4	76.50	MPi, SOHC	55/75			
BBY	1390	4	76.50		55/75			
AFK	1390	4	76.50	MPi, DOHC	74/100			
ANM/AQQ	1390	4	76.50	DOHC	74/100			
AUB	1390	4	76.50	MPi, DOHC	74/100			
Lupo 1.4L FSI				02/01 → 07/05	142	AB5701 (MLS) 30-029313-10		EB5700 [8] 22-29313-00/0
ARR	1390	4	76.50	Injection, DOHC	77/105			
Lupo 1.4L TDI Diesel				01/99 → 07/05	143	AD5650 (MLS), 1.45mm, 1 Hole 30-029663-00 AD5660 (MLS), 1.53mm, 2 Holes 30-029664-00 AD5670 (MLS), 1.61mm, 3 Holes 30-029665-00	CD5650▲ 21-29671-20/0	ED5650 [8] (22-29671-00/0)
AMF	1422	3	79.50	PDi, SOHC	55/75			
Lupo 1.6L GTI				09/00 → 07/05	144	AC5280 (MLS) 30-029466-00		EB5700 [8] 22-29313-00/0
AVY	1598	4	76.50	DOHC	92/125			
Lupo 1.7L SDI Diesel				09/98 → 07/05	145	BX800 (MLS), 1.45mm, 1 Hole 30-028686-00 BX810 (MLS), 1.53mm, 2 Holes 30-028687-00 BX820 (MLS), 1.61mm, 3 Holes 30-028688-00	DX801▲ 21-27921-21/0	EA801 [8]
AKU	1716	4	79.50	SOHC	44/60			
Multivan 1.9L TDI Diesel				04/03 →	146	AF5381 (MLS), 1.49mm, 1 Hole 30-030098-10 AF5391 (MLS), 1.57mm, 2 Holes 30-030099-10 AF5401 (MLS), 1.65mm, 3 Holes 30-030100-10	CC5230▲ 21-29463-21/0	EB5370 [8] 22-29314-00/0
AXB	1896	4	79.50		77/105			
Multivan 1.9L TDI Diesel				06/06 →	147	AF5381 (MLS), 1.49mm, 1 Hole 30-030098-10 AF5391 (MLS), 1.57mm, 2 Holes 30-030099-10 AF5401 (MLS), 1.65mm, 3 Holes 30-030100-10		EF5380 22-30369-00/0
BRS	1896	4	79.50	Direct Injection, SOHC	75/102			

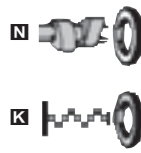
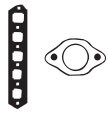

HBS311 Ⓢ (22-33035B) M12x1.75x115mm (x8)	JD5278 ■ (31-029671-00) JD5279 ■ (31-029710-00)	JM7032 50-030224-00	HR397 [57] 34-000410-00	HR5068 ■ (24-30653-84/0)	NA5124 32x47x10mm, PTFE (50-319433-00) NA5106 ■ 35x48x10mm, PTFE (50-319430-00) LK5003 ■ [3] 85x131x15.7mm, PTFE (50-319434-00)	HL5034 [245]■
HBS362 Ⓢ (22-39031B) M9x1.25x162mm (x10)	JD597 ■ ■ 50-350355-00 JD5318 ■ (31-029901-00)		HR397 [57] 34-000410-00	HR817 ■ 24-30614-78/0	NA5185 32x42x6mm, FPM (50-319489-00) NA5185 ■ 32x42x6mm, FPM (50-319489-00) LK5011 ■ [3] [78] 85x131x15.94mm, PTFE	
HBS249 Ⓢ (22-33025B) M9x1.25x138mm (x10)	JD5228 ■ (x4) (50-029071-00) JD5298 ■ (31-029825-00)	HR397 [57] 34-000410-00	HR397 [57] 34-000410-00	HR791 ■ 24-30614-76/0	NA5180 27x42x8mm, FPM (50-319484-00) NA5185 ■ 32x42x6mm, FPM (50-319489-00)	KA5025 [13] KK5551 [81]
HBS249 Ⓢ (22-33025B) M9x1.25x138mm (x10)	JD5809 ■ 31-030229-00 JD5298 ■ (31-029825-00)	HR397 [57] 34-000410-00	HR397 [57] 34-000410-00	HR791 ■ 24-30614-76/0	NA5180 27x42x8mm, FPM (50-319484-00) NA5185 ■ 32x42x6mm, FPM (50-319489-00) LK5011 ■ [3] [78] 85x131x15.94mm, PTFE	
HBS264 Ⓢ (22-33026B) M12x1.75x166mm (x8)	JD5278 ■ (31-029671-00) JD5279 ■ (31-029710-00)	JM7032 50-030224-00	HR397 [57] 34-000410-00	HR5068 ■ (24-30653-84/0)	NA5124 32x47x10mm, PTFE (50-319433-00) NA5106 ■ 35x48x10mm, PTFE (50-319430-00) LK5003 ■ [3] 85x131x15.7mm, PTFE (50-319434-00)	HL5034 [245]■
HBS316 Ⓢ (22-33036B) M9x1.25x97mm (x10)	JD5373 ■ (31-029966-00) JD5298 ■ (31-029825-00)	HR397 [57] 34-000410-00	HR397 [57] 34-000410-00	HR791 ■ 24-30614-76/0	NA5180 ■ 27x42x8mm, FPM (50-319484-00) NA5185 ■ 32x42x6mm, FPM (50-319489-00) LK5011 ■ [3] [78] 85x131x15.94mm, PTFE	KA5025 [13] KK5551 [81]
HBS018 Ⓢ (22-39024B) M12x1.75x115mm (x10)	JD170 ■ 31-026556-10 JC152 ■ (x4) 31-026555-00	JP003 50-027921-00	JJ609 (50-027500-00) (ACM)	HR816 ■ 24-30653-85/0	NA5001 32x47x10mm, FPM (50-303185-50) NA5001 ■ 32x47x10mm, FPM (50-303185-50) NA5133 ■ 85x105x11mm, FPM (24-30727-87/0) →Eng.AKU 013 000 LK5006 ■ [3] 85x131x16mm, PTFE (50-319448-00) Eng.AKU 013 001→	HL5020 [245]■ NA5278 [54]
HBS300 Ⓢ (22-33034B) M12x1.75x166mm (x10)	JD170 ■ 31-026556-10 JD600 ■ 31-028454-00	JM5203 50-029934-00	HR397 [57] 34-000410-00	HR816 ■ 24-30653-85/0	NA5124 32x47x10mm, PTFE (50-319433-00) NA5106 ■ 35x48x10mm, PTFE (50-319430-00) LK5003 ■ [3] 85x131x15.7mm, PTFE (50-319434-00)	HL5034 [245]■
HBS300 Ⓢ (22-33034B) M12x1.75x166mm (x10)	JD170 ■ 31-026556-10 JD600 ■ 31-028454-00		HR397 [57] 34-000410-00	HR816 ■ 24-30653-85/0	NA5124 32x47x10mm, PTFE (50-319433-00) NA5106 ■ 35x48x10mm, PTFE (50-319430-00) LK5012 ■ [3] [85] 85x132x15.7mm, ACM (50-319535-00)	

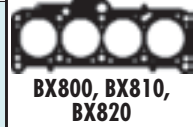
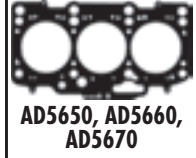
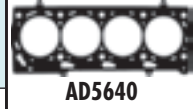
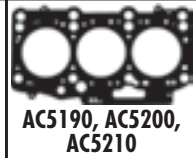









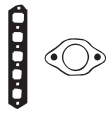

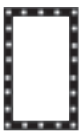

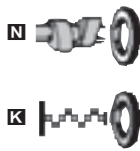















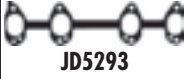

















































KW/PS



Multivan 2.0L				04/03 →	148	AB5370 (MLS)		EB5370 [8]
AXA	1984	4	82.50		85/116	30-029314-00		22-29314-00/0
Multivan 2.5L TDI Diesel				04/03 →	149	AG8920 (MLS), 1.27mm, 1 Hole		
Multivan 2.5L TDI 4motion Diesel				07/04 →		30-030244-00		
BNZ	2460	5	81.00	Direct Injection, SOHC	96/131	AG8820 (MLS), 1.35mm, 2 Holes		
AXD	2461	5	81.00	PDi	96/131	30-030215-00		
AXE	2461	5	81.00	PDi	128/174	AG8930 (MLS), 1.43mm, 3 Holes		
BPC	2461	5	81.00	Direct Injection, SOHC	128/174	(30-030245-00)		
Multivan 3.2L V6				02/04 →06/04	150	AG9610 (MLS)	CG9610	
Multivan 3.2L V6 4motion				07/04 →		30-030350-00	21-30350-00/0	
BDL	3189	6	84.00	DOHC, V6	170/231			
BKK	3189	6	84.00		173/235			
New Beetle 1.4L				11/01 →	151	AB5701 (MLS)	CB5700	EB5700 [8]
New Beetle Convertible 1.4L				01/03 →		30-029313-10	21-29313-20/0	22-29313-00/0
BCA	1390	4	76.50		55/75			
New Beetle 1.6L				10/99 →09/00	152	AC5220 (MLS)	CC5221	EC5220 [8]
AWH	1595	4	81.00		74/100	30-029462-00	21-29462-21/0	(22-29462-00/0)
New Beetle 1.6L				09/00 →	153	AC5220 (MLS)	CC5222	EC5220 [8]
New Beetle Convertible 1.6L				01/03 →		30-029462-00	21-29462-22/0	(22-29462-00/0)
AYD/BFS	1595	4	81.00		75/102			
New Beetle 1.8L T				10/99 →	154	AY970 (MLS)	CY971	EY841
New Beetle Convertible 1.8L T				01/04 →		30-028495-00	21-28495-21/0	22-28897-02/0
AGU	1781	4	81.00	Injection, DOHC	110/150			
APH	1781	4	81.00		110/150			
AVC	1781	4	81.00	DOHC	110/150			
AWU/AWV	1781	4	81.00	SOHC	110/150			
BKF	1781	4	81.00	Injection, DOHC	110/150			
New Beetle 1.9L TDI Diesel				02/01 →	155	AF5381 (MLS), 1.49mm, 1 Hole	CC5230	EB5370 [8]
New Beetle Convertible 1.9L TDI Diesel				03/03 →		30-030098-10	21-29463-21/0	22-29314-00/0
ATD	1896	4	79.50		74/100	AF5391 (MLS), 1.57mm, 2 Holes		
AXR	1896	4	79.50	PDi, SOHC	74/100	30-030099-10		
BEW	1896	4	79.50	Direct Injection, SOHC	74/101	AF5401 (MLS), 1.65mm, 3 Holes		
BSW	1896	4	79.50	Direct Injection, SOHC	77/105	30-030100-10		











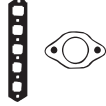

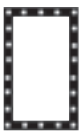

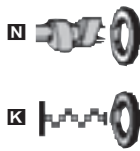































								
HBS246 ® (22-33024B) M10x1.50x120mm (x10)	JD5292  (31-029815-00) JD5293  (31-029816-00)	JM5103 (50-029547-00)	HR397 [57] 34-000410-00	HR816  24-30653-85/0	 NA5124 32x47x10mm, PTFE (50-319433-00)  NA5106  35x48x10mm, PTFE (50-319430-00)  LK5003  [3] 85x131x15.7mm, PTFE (50-319434-00)	HL5034 [245] 		 AB5370  AC5220  AY970  JD170  JD5228  JD5292  JD5293  JD5298  JD600  JD604  JD605  JM5103  JP024
		HR397 [57] 34-000410-00	HR397 [57] 34-000410-00					
HBS466 (22-33039B)	JD5874  50-030351-00 (FPM)	JM7045 50-030133-00 (Rubber)	HR397 [57] 34-000410-00	HR5062  24-30614-73/0	 NA5106  35x48x10mm, PTFE (50-319430-00)			
HBS249 ® (22-33025B) M9x1.25x138mm (x10)	JD5228  (x4) (50-029071-00) JD5298  (31-029825-00)	HR397 [57] 34-000410-00	HR397 [57] 34-000410-00	HR791  24-30614-76/0	 NA5180 27x42x8mm, FPM (50-319484-00)  NA5185  32x42x6mm, FPM (50-319489-00)  LK5011  [3] [78] 85x131x15.94mm, PTFE	KA5025 [13]		
HBS246 ® (22-33024B) M10x1.50x120mm (x10)	JD5340  (x4) (50-029939-00) JD5293  (31-029816-00)	JP024 50-027505-00	HR397 [57] 34-000410-00	HR816  24-30653-85/0	 NA5124 32x47x10mm, PTFE (50-319433-00)  NA5106  35x48x10mm, PTFE (50-319430-00)  LK5008  [3] 85x131x15.7mm, PTFE (50-319472-00)	HL5034 [245] 		
HBS246 ® (22-33024B) M10x1.50x120mm (x10)	JD5340  (x4) (50-029939-00) JD5293  (31-029816-00)	JM5205 50-029938-00 (Rubber)	HR397 [57] 34-000410-00	HR817  24-30614-78/0	 NA5124 32x47x10mm, PTFE (50-319433-00)  NA5106  35x48x10mm, PTFE (50-319430-00)  LK5008  [3] 85x131x15.7mm, PTFE (50-319472-00)	HL5034 [245] 		
HBS268 ® (22-33031B) M10x1.50x120mm (x10)	JD604  (31-028824-00) JD605  31-028826-00	HL732  24-28815-00/0	HR397 [57] 34-000410-00 JH5117 (50-030046-00) AGU, AVC, AWU	HR822 	 NA5124 (x2) 32x47x10mm, PTFE (50-319433-00)  NA5106  35x48x10mm, PTFE (50-319430-00)  LK5003  [3] 85x131x15.7mm, PTFE (50-319434-00)	HL5040 [245] 		
HBS300 ® (22-33034B) M12x1.75x166mm (x10)	JD170  31-026556-10 JD600  31-028454-00	JM5203 50-029934-00	HR397 [57] 34-000410-00	HR816  24-30653-85/0	 NA5124 32x47x10mm, PTFE (50-319433-00)  NA5106  35x48x10mm, PTFE (50-319430-00)  LK5003  [3] 85x131x15.7mm, PTFE (50-319434-00)	HL5034 [245] 		



KW/PS



New Beetle 1.9L TDI Diesel					01/98 → 02/01	156			
ALH	1896	4	79.50			66/89	BZ010 (MLS), 1.45mm, 1 Hole 30-028910-10 →Eng.ALH 085 000 BZ020 (MLS), 1.53mm, 2 Holes 30-028911-10 →Eng.ALH 085 000 BZ030 (MLS), 1.61mm, 3 Holes 30-028912-10 →Eng.ALH 085 000 BZ040 (MLS), 1.47mm, 1 Hole 30-028915-10 Eng.ALH 085 001 → BZ050 (MLS), 1.57mm, 2 Holes 30-028916-10 Eng.ALH 085 001 → BZ060 (MLS), 1.67mm, 3 Holes 30-028917-10 Eng.ALH 085 001 →	DZ010 21-26556-20/0	EC060 [8] 22-28897-00/0
New Beetle 2.0L					01/98 →	157			
AEG	1984	4	82.50			85/116	AB5370 (MLS) 30-029314-00 APK, AQY, AZG, AEG	CB5370 21-29314-20/0 APK, AQY, AEG-PRML2	EB5370 [8] 22-29314-00/0 APK, AQY, AZG, AEG
APK	1984	4	82.50	SOHC	85/116				
AQY	1984	4	82.50		85/116				
AVH	1984	4	82.50	Injection, SOHC	85/116				
AZG/AZJ	1984	4	82.50		85/116				
BER/BEV	1984	4	82.50	SOHC	85/116				
New Beetle V5					10/00 →	158			
AQN	2324	5	81.00	DOHC, V5		125/170		CG9620 21-30348-00/0 (MLS)	EG5010
Passat 1.6L					11/00 → 05/05	159			
ALZ	1595	4	81.00	MPi, SOHC		74/100	AC5220 (MLS) 30-029462-00	CC5223 21-29462-00/0	EC5220 [8] (22-29462-00/0)
Passat 1.6L					08/87 → 03/88	160			
PP	1595	4	81.00			51/70	BM360 (Fibre) 30-026807-30	DM360 21-26807-24/0	EG873
Passat 1.6L					08/80 → 03/88	161			
WV	1588	4	79.50	SOHC		55/75	BG870 (Fibre) 30-024224-10	DG871 21-24224-24/0	EG873
YN	1588	4	79.50		55/75				
Passat 1.6L					02/88 → 09/91	162			
TF	1595	4	81.00	Monomotronic, SOHC		53/55/ 72/75	BM360 (Fibre) 30-026807-30	DM368 21-26807-20/0	EG873
EZ	1595	4	81.00		55/75				

								
HBS018 Ⓞ (22-39024B) M12x1.75x115mm (x10)	JD170 ■ 31-026556-10 JC152 ■ (x4) 31-026555-00			HR397 [57] 34-000410-00	HR816 ■ 24-30653-85/0	NA5001 32x47x10mm, FPM (50-303185-50) NB716 ■ 35x48x10mm, FPM (50-306067-50) LK5006 ■ [3] 85x131x16mm, PTFE (50-319448-00)	NA5278 [54]	 AB5370  AC5220  BG870  BM360  BZ010, BZ020, BZ030  BZ040, BZ050, BZ060
HBS246 Ⓞ (22-33024B) M10x1.50x120mm (x10) APK, AQY, AZG, AEG	JD5291 ■ (31-029814-00) APK, AQY, AZG, AEG LA5204 ■ (x4) (50-350416-00) AEG JD5293 ■ (31-029816-00) APK, AQY, AZG, AEG	JM5103 (50-029547-00) AZG, AEG-PRML8 JPO24 50-027505-00 APK, AQY, AEG-PRML2	HR397 [57] 34-000410-00 APK, AQY, AZG, AEG JH5117 (50-030046-00) APK, AQY	HR816 ■ 24-30653-85/0 APK, AQY, AZG, AEG	NA5124 32x47x10mm, PTFE (50-319433-00) APK, AQY, AZG, AEG NA5106 ■ 35x48x10mm, PTFE (50-319430-00) APK, AQY, AZG, AEG LK5003 ■ [3] 85x131x15.7mm, PTFE (50-319434-00) APK, AQY, AZG, AEG	HL5034 [245]■	 JC152  JC243  JC478  JD170  JD5291  JD5293  JD5341  JD605  JD606  JE160  LA5204  PA459	
		JM5234 (50-029982-00)	HR397 [57] 34-000410-00	HR822 ■	NA5106 ■ 35x48x10mm, PTFE (50-319430-00)		 JD605  JD606  JE160  LA5204  PA459	
HBS246 Ⓞ (22-33024B) M10x1.50x120mm (x10)	JD5341 ■ (x4) (50-029940-00) JD5813 ■ 31-030233-00 JD605 ■ 31-028826-00 JD606 ■ (31-028918-00)	JM5205 50-029938-00 (Rubber)	HR397 [57] 34-000410-00	HR817 ■ 24-30614-78/0	NA5124 32x47x10mm, PTFE (50-319433-00) NA5106 ■ 35x48x10mm, PTFE (50-319430-00) LK5008 ■ [3] 85x131x15.7mm, PTFE (50-319472-00)	HL5034 [245]■	 JD5291  JD5293  JD5341  JD605  JD606  JE160  LA5204  PA459	
HBS043 Ⓞ (22-39001B) M11x1.50x95mm (x10)	JC478 ■ 31-026397-00 PA459 ■ 50-024870-00 (NBR) JC152 ■ (x4) 31-026555-00	HL457 ■ [79] 24-25753-01/0 (Cork) HM5053 ■ [80] 24-28543-00/0 (ACM) (Rubber)	JJ140 (31-026554-10)	HR569 ■ 24-30667-00/0	NA5001 32x47x10mm, FPM (50-303185-50) NA5001 ■ 32x47x10mm, FPM (50-303185-50) NA5133 ■ 85x105x11mm, FPM (24-30727-87/0)	HL5020 [245]■ NB567 [2]■ KA5020 [13]	 JD605  JD606  JE160  LA5204  PA459	
HBS043 Ⓞ (22-39001B) M11x1.50x95mm (x10)	JC243 ■ (31-026727-00) JC152 ■ (x4) 31-026555-00	HL457 ■ [79] 24-25753-01/0 (Cork)	JJ140 (31-026554-10)	HR569 ■ 24-30667-00/0	NA5001 32x47x10mm, FPM (50-303185-50) NA5001 ■ 32x47x10mm, FPM (50-303185-50) NA5133 ■ 85x105x11mm, FPM (24-30727-87/0)	HL5020 [245]■ NB567 [2]■ KA5020 [13]	 LA5204  PA459	
HBS043 Ⓞ (22-39001B) M11x1.50x95mm (x10)	JC478 ■ 31-026397-00 PA459 ■ 50-024870-00 (NBR) JC152 ■ (x4) 31-026555-00  JE160 (31-024869-00)	HL457 ■ [79] 24-25753-01/0 (Cork) HM5053 ■ [80] 24-28543-00/0 (ACM)	JJ140 (31-026554-10)	HR569 ■ 24-30667-00/0	NA5001 32x47x10mm, FPM (50-303185-50) NA5001 ■ 32x47x10mm, FPM (50-303185-50) NA5133 ■ 85x105x11mm, FPM (24-30727-87/0)	HL5020 [245]■ KA5020 [13]	 HL457  JM5103	











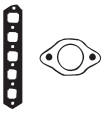

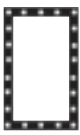

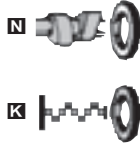



VW

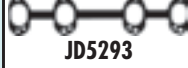

KW/PS



Passat 1.6L					08/80 → 03/88	163	BM360 (Fibre)	DM360	EG873
RL	1595	4	81.00	SOHC		53/72	30-026807-30	21-26807-24/0	
DT	1595	4	81.00			55/75			
Passat 1.6L					05/05 →	164	AC5220 (MLS)	CC5222	
BSE/BSF	1595	4	81.00	SOHC		75/102	30-029462-00	21-29462-22/0	
Passat 1.6L					07/94 → 08/96	165	AY940 (MLS)	CY940	EB970
AEK/AFT	1595	4	81.00	SOHC		74/100	30-028383-00	21-28383-20/0 AEK CY941 21-28383-21/0 AFT	22-27500-01/0 AEK
Passat 1.6L					10/96 → 11/00	166	AC5220 (MLS)	CC5220	EC5220 [8]
AHL/ANA/ARM	1595	4	81.00	SOHC		74/100	30-029462-00	21-29462-20/0	(22-29462-00/0)
ADP	1595	4	81.00			75/102	AHL, ANA, ARM AY940 (MLS) 30-028383-00 ADP	AHL, ANA, ARM CY942 21-28383-22/0 ADP	AHL, ANA, ARM

								 AC5220	 JJ140
HBS043 Ⓞ [22-39001B] M11x1.50x95mm (x10)	JC478 ■ 31-026397-00 PA459 ■ 50-024870-00 (NBR) JC152 ■ (x4) 31-026555-00	HL457 ■ [79] 24-25753-01/0 (Cork) HM5053 ■ [80] 24-28543-00/0 (ACM)	JJ140 [31-026554-10]	HR569 ■ 24-30667-00/0	NA5001 32x47x10mm, FPM (50-303185-50) NA5001 ■ 32x47x10mm, FPM (50-303185-50) NA5133 ■ 85x105x11mm, FPM (24-30727-87/0)	HL5020 [245]■ NB567 [2]■ KA5020 [13]	 AY940  BM360  JC152  JC478  JD5293  JD5341  JD599  JD600  PA459  HL457  JP024		
HBS246 Ⓞ [22-33024B] M10x1.50x120mm (x10)	JD5340 ■ (x4) (50-029939-00) JD5293 ■ (31-029816-00)	JM5205 50-029938-00 (Rubber)	HR397 [57] 34-000410-00	HR817 ■ 24-30614-78/0	NA5124 32x47x10mm, PTFE (50-319433-00) NA5106 ■ 35x48x10mm, PTFE (50-319430-00)	HL5034 [245]■			
HBS043 Ⓞ [22-39001B] M11x1.50x95mm (x10)	JD599 ■ ■ (x4) (31-027926-00) JD600 ■ 31-028454-00 JF205 (31-025070-00)	JP024 50-027505-00		HR569 ■ 24-30667-00/0 AEK HR816 ■ 24-30653-85/0 AFT	NA5001 32x47x10mm, FPM (50-303185-50) NA5001 ■ 32x47x10mm, FPM (50-303185-50) NA5133 ■ 85x105x11mm, FPM (24-30727-87/0)	HL5020 [245]■ NA5278 [54]			
HBS043 Ⓞ [22-39001B] M11x1.50x95mm (x10) ADP HBS246 Ⓞ [22-33024B] M10x1.50x120mm (x10) AHL, ANA, ARM	JD5341 ■ (x4) (50-029940-00) AHL, ANA, ARM JC152 ■ (x4) 31-026555-00	JP024 50-027505-00	HR397 [57] 34-000410-00 AHL, ANA, ARM JH5117 (50-030046-00) AHL, ANA, ARM JJ609 (50-027500-00) (ACM) ADP	HR816 ■ 24-30653-85/0	NA5001 32x47x10mm, FPM (50-303185-50) ADP NA5124 32x47x10mm, PTFE (50-319433-00) AHL, ANA, ARM NA5001 ■ 32x47x10mm, FPM (50-303185-50) ADP NA5106 ■ 35x48x10mm, PTFE (50-319430-00) AHL, ANA, ARM NA5133 ■ 85x105x11mm, FPM (24-30727-87/0) ADP LK5008 ■ [3] 85x131x15.7mm, PTFE (50-319472-00) AHL, ANA, ARM	HL5020 [245]■ ADP HL5034 [245]■ AHL, ANA, ARM			



KW/PS

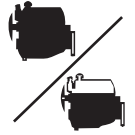

Passat 1.6L D Diesel

02/79 → 03/88

167

CR/JK
1588 4 76.50

40/54

- BH720** (Fibre), 1.50mm, 2 Holes
30-024428-10
→Ch.32-B-085 000
- BH730** (Fibre), 1.60mm, 3 Notches
30-024429-10
→Ch.32-B-085 000
- BN080** (Fibre), 1.40mm, 1 Notch
30-024901-30
Ch.32-B-085 001 →
→07/85
- BN090** (Fibre), 1.50mm, 2 Notches
30-024849-30
Ch.32-B-085 001 →
→07/95
- BN100** (Fibre), 1.60mm, 3 Notches
30-024850-30
Ch.32-B-085 001 →
→07/85
- BN940** (Fibre), 1.53mm, 1 Hole
30-026230-30
08/85 →
- BN950** (Fibre), 1.57mm, 2 Holes
30-026231-30
08/85 →
- BN960** (Fibre), 1.61mm, 3 Holes
30-026232-30
08/85 →

DD501▲ [83]
21-25753-26/0

EG873

Passat 1.6L FSI

03/05 →

168

BLF
1598 4 76.50

Injection, DOHC

85/115

AG8850 (MLS)
(30-030218-00)

CG8850
21-30218-00/0

Passat 1.6L TD Diesel

04/82 → 03/88

169

CY
1588 4 76.50

51/69

- BN080** (Fibre), 1.40mm, 1 Notch
30-024901-30
→07/85
- BN090** (Fibre), 1.50mm, 2 Notches
30-024849-30
→07/85
- BN100** (Fibre), 1.60mm, 3 Notches
30-024850-30
→07/85
- BN940** (Fibre), 1.53mm, 1 Hole
30-026230-30
08/85 →
- BN950** (Fibre), 1.57mm, 2 Holes
30-026231-30
08/85 →
- BN960** (Fibre), 1.61mm, 3 Holes
30-026232-30
08/85 →

DD502▲ [83]
(21-25753-27/0)

EG873

Passat 1.6L TD Diesel

05/86 → 09/93

170

RA/SB
1588 4 76.50

59/80

- BN940** (Fibre), 1.53mm, 1 Hole
30-026230-30
- BN950** (Fibre), 1.57mm, 2 Holes
30-026231-30
- BN960** (Fibre), 1.61mm, 3 Holes
30-026232-30

DD502▲ [83]
(21-25753-27/0)

EG873

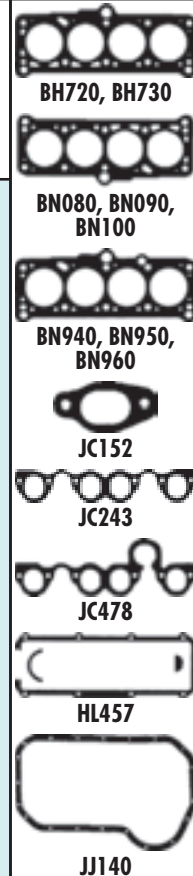
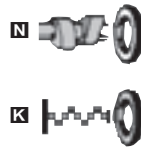
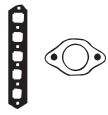

HBS018Ⓢ
(22-39024B)
M12x1.75x115mm (x10)

JC478■
31-026397-00
JC152■ (x4)
31-026555-00

HL457■ [79]
24-25753-01/0
(Cork)
HM5053■ [80]
24-28543-00/0
(ACM)

JJ140
(31-026554-10)

HR569■
24-30667-00/0

■ **NA5001** 32x47x10mm, FPM
(50-303185-50)
■ **NA5001**■ 32x47x10mm, FPM
(50-303185-50)
■ **NA5133**■ 85x105x11mm, FPM
(24-30727-87/0)

HL5020 [245]■
KA5020 [13]

HBS249Ⓢ
(22-33025B)
M9x1.25x138mm (x10)

JD5809■
31-030229-00
JD5814■
31-030234-00

HR397 [57]
34-000410-00

HR397 [57]
34-000410-00

HR791■
24-30614-76/0

■ **NA5106**■ 35x48x10mm, PTFE
(50-319430-00)
■ **LK5011**■ [3] [78] 85x131x15.94mm,
PTFE
→07/05
■ **LK5013**■ [3] [118] 85x111x15.5mm
08/05→

HBS018Ⓢ
(22-39024B)
M12x1.75x115mm (x10)

JC243■
(31-026727-00)
JC152■ (x4)
31-026555-00

HL457■ [79]
24-25753-01/0
(Cork)

JJ140
(31-026554-10)

HR569■
24-30667-00/0

■ **NA5001** 32x47x10mm, FPM
(50-303185-50)
■ **NA5001**■ 32x47x10mm, FPM
(50-303185-50)
■ **NA5133**■ 85x105x11mm, FPM
(24-30727-87/0)

HL5020 [245]■
KA5020 [13]
NA5278 [54]

HBS018Ⓢ
(22-39024B)
M12x1.75x115mm (x10)

JC243■
(31-026727-00)
JC152■ (x4)
31-026555-00

HL457■ [79]
24-25753-01/0
(Cork)
HM5053■ [80]
24-28543-00/0
(ACM)

JJ140
(31-026554-10)

HR569■
24-30667-00/0

■ **NA5001** 32x47x10mm, FPM
(50-303185-50)
■ **NA5001**■ 32x47x10mm, FPM
(50-303185-50)
■ **NA5133**■ 85x105x11mm, FPM
(24-30727-87/0)

HL5020 [245]■
NB567 [2]■
KA5020 [13]
NA5278 [54]











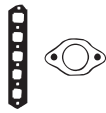

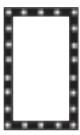

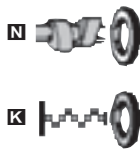























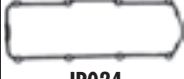

























































VW



KW/PS



Passat 1.8L						10/96 → 11/00	171	AY970 (MLS)	CY970	EY840
Passat 1.8L Syncro / 4motion						10/96 → 11/00		30-028495-00	21-28495-20/0	22-28825-00/0
Passat 1.8L T						10/96 → 11/00				
AFY	1781	4	81.00	DOHC	85/116					
ADR/APT/ARG	1781	4	81.00	Injection, DOHC	92/125					
AEB	1781	4	81.00	Injection, DOHC	110/150					
ANB	1781	4	81.00		110/150					
APU	1781	4	81.00	DOHC	110/150					
Passat 1.8L						05/86 → 03/88	172	BM360 (Fibre)	DM360	EG873
RM	1781	4	81.00		64/87		30-026807-30	21-26807-24/0		
Passat 1.8L						01/83 → 03/88	173	BM360 (Fibre)	DM361 [83]	EG873
Passat 1.8L Syncro						01/86 → 03/88		30-026807-30	21-26807-22/0	
DS/JN/JV	1781	4	81.00		66/89					
Passat 1.8L						12/83 → 03/88	174	BM360 (Fibre)	DM363 [83]	EG873
DZ	1781	4	81.00		82/111		30-026807-30	21-26807-27/0		
Passat 1.8L						04/88 → 07/93	175	BM360 (Fibre)	DM368	EG873
PF	1781	4	81.00	Digifant	79/107		30-026807-30	21-26807-20/0		
PB	1781	4	81.00	Digifant	82/111					
Passat 1.8L						08/90 → 05/97	176	BM360 (Fibre)	DM366	
AAM	1781	4	81.00	Monomotronic	55/75		30-026807-30 → Eng.AAM 408 197 BZ910 (MLS) 30-027935-00 Eng.AAM 408 198 →	21-26807-26/0 → Ch.31-P-160 000 DM367 21-26807-30/0 Ch.31-P-160 001 → → Eng.AAM 408 197 DZ910 21-27935-20/0 Eng.AAM 408 198 →		











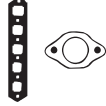

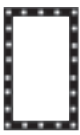

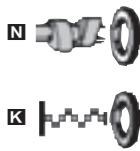





























								
HBS171  (22-39027B) M11x1.50x101mm (x10)	JD604  (31-028824-00) JD605  31-028826-00  JE689 (31-024039-00)	HL732  24-28815-00/0	JJ610 (50-028825-00)	HR822  24-30667-00/0	 NA5001 32x47x10mm, FPM (50-303185-50)  NA5001 32x47x10mm, FPM (50-303185-50)  LK5006 [3] 85x131x16mm, PTFE (50-319448-00)  NA5133 85x105x11mm, FPM (24-30727-87/0)	HL5020 [245] 	 AY970  BM360  BZ910  JC152  JC478  JD5235  JD604  JD605  JE160  JE689  PA459  HL457  JP024  JJ140  JJ610	
HBS043  (22-39001B) M11x1.50x95mm (x10)	JC478  31-026397-00 PA459  50-024870-00 (NBR) JC152  (x4) 31-026555-00  JE160 (31-024869-00) JN  JE689 (31-024039-00) DS	HL457  [79] 24-25753-01/0 (Cork) HM5053  [80] 24-28543-00/0 (ACM)	JJ140 (31-026554-10)	HR569  24-30667-00/0	 NA5001 32x47x10mm, FPM (50-303185-50)  NA5001 32x47x10mm, FPM (50-303185-50)  NA5133 85x105x11mm, FPM (24-30727-87/0)	HL5020 [245]  NB567 [2]  KA5020 [13]		
HBS043  (22-39001B) M11x1.50x95mm (x10)	JC478  31-026397-00 PA459  50-024870-00 (NBR) JC152  (x4) 31-026555-00  JE160 (31-024869-00) JN  JE689 (31-024039-00) DS	HL457  [79] 24-25753-01/0 (Cork) HM5053  [80] 24-28543-00/0 (ACM)	JJ140 (31-026554-10)	HR569  24-30667-00/0	 NA5001 32x47x10mm, FPM (50-303185-50)  NA5001 32x47x10mm, FPM (50-303185-50)  NA5133 85x105x11mm, FPM (24-30727-87/0)	HL5020 [245]  KA5020 [13]		
HBS043  (22-39001B) M11x1.50x95mm (x10)	JC478  31-026397-00 PA459  50-024870-00 (NBR) JC152  (x4) 31-026555-00	HL457  [79] 24-25753-01/0 (Cork) HM5053  [80] 24-28543-00/0 (ACM)	JJ140 (31-026554-10)	HR569  24-30667-00/0	 NA5001 32x47x10mm, FPM (50-303185-50)  NA5001 32x47x10mm, FPM (50-303185-50)  NA5133 85x105x11mm, FPM (24-30727-87/0)	HL5020 [245]  NB567 [2]  KA5020 [13]		
HBS043  (22-39001B) M11x1.50x95mm (x10)	JC478  31-026397-00 PA459  50-024870-00 (NBR) JC152  (x4) 31-026555-00  JE160 (31-024869-00)	HL457  [79] 24-25753-01/0 (Cork) HM5053  [80] 24-28543-00/0 (ACM)	JJ140 (31-026554-10)	HR569  24-30667-00/0 HR816  24-30653-85/0 Eng.AAM 408 198→	 NA5001 32x47x10mm, FPM (50-303185-50)  NA5001 32x47x10mm, FPM (50-303185-50)  NA5133 85x105x11mm, FPM (24-30727-87/0)	HL5020 [245]  NB567 [2]  KA5020 [13] NA5278 [54]		
HBS043  (22-39001B) M11x1.50x95mm (x10) →Eng.AAM 408 197	JC478  31-026397-00 →Eng.AAM 408 197 PA459  50-024870-00 (NBR) →Eng.AAM 408 197 JD5235  (31-028554-00) Eng.AAM 408 198→ JC152  (x4) 31-026555-00  JE5076 (31-028373-00)	JP024 50-027505-00 Ch.31-P-160 001→ HL457  [79] 24-25753-01/0 (Cork) →Ch.31-P-160 001	JJ140 (31-026554-10)	HR569  24-30667-00/0 →Eng.AAM 408 197	 NA5001 32x47x10mm, FPM (50-303185-50)  NA5001 32x47x10mm, FPM (50-303185-50)  NA5133 85x105x11mm, FPM (24-30727-87/0)	HL5020 [245] 		



KW/PS



Passat 1.8L				02/88 → 05/97	177	BM360 (Fibre)	DM366	EG873
ABS	1781	4	81.00	Monomotronic	66/89	30-026807-30	21-26807-26/0	RP
ADZ	1781	4	81.00	SOHC	66/89	→Eng.ABS 935 645	→Ch.31-P-160 000	
RP	1781	4	81.00		66/89	→Eng.ABZ 011 565	DM368 21-26807-20/0	
						RP	RP	
						BZ910 (MLS) 30-027935-00	DM367 21-26807-30/0	
						Eng.ABS 935 646 →	Ch.31-P-160 001 →	
						Eng.ADZ 011 566 →	→Eng.ABS 935 645	
							→Eng.ADZ 011 565	
							DZ910 21-27935-20/0	
							Eng.ABS 935 646 →	
							Eng.ADZ 011 566 →	
Passat 1.8L 16V				04/88 → 12/89	178	BM360 (Fibre)	DM365	ET811
						30-026807-30	21-26807-21/0	(22-26554-40/0)
Passat 1.8L GL				08/91 → 09/93				
Passat 1.8L Variant				08/91 → 09/93				
KR	1781	4	81.00	K-Jetronic	98/133			
Passat 1.8L G60 Syncro				08/88 → 05/97	179	BY630 (MLS)	DT819	
PG	1781	4	81.00	Digifant	118/160	30-027516-00	21-27516-21/0	
Passat 1.8L T				02/01 → 05/05	180	AY970 (MLS)	CY971	EY841
						30-028495-00	21-28495-21/0	22-28897-02/0
Passat 1.8L T 20V				11/00 → 05/05				
AWL	1781	4	81.00	Injection, DOHC	110/150			
AWT	1781	4	81.00		110/150			
AWM	1781	4	81.00	DOHC	125/170			
Passat 1.9L D Diesel				05/89 → 10/93	181	BV850 (MLS), 1.53mm, 1 Hole	DV850▲	EC030 [8]
IY	1896	4	79.50		47/50/ 64/68	30-028545-00	21-26557-20/0	22-26384-04/0
						BV860 (MLS), 1.57mm, 2 Holes 30-028546-00	→Eng.IY 580 000	
						BV870 (MLS), 1.61mm, 3 Holes 30-028547-00	DV851▲ 21-26557-21/0	
							Eng.IY 580 001 →	











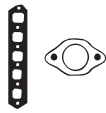

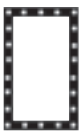

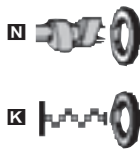
								
HBS043 Ⓞ [22-39001B] M11x1.50x95mm (x10) →Eng.ABS 935 645 →Eng.ABS 935 645 →Eng.ADZ 011 565 RP	JC478 ■ 31-026397-00 →Eng.ABS 935 645 →Eng.ADZ 011 565 RP PA459 ■ 50-024870-00 (NBR) →Eng.ABS 935 645 →Eng.ADZ 011 565 RP JD5235 ■ (31-028554-00) Eng.ABS 935 646 → Eng.ADZ 011 566 → JC152 ■ (x4) 31-026555-00  (31-024869-00) RP  (31-028373-00) ABS	JP024 50-027505-00 Ch.31-P-160 001 → ADZ HL457 ■ [79] 24-25753-01/0 (Cork) →Ch.31-P-160 000 RP HM5053 ■ [80] 24-28543-00/0 (ACM) →Ch.31-P-160 000 RP	JJ140 (31-026554-10)	HR569 ■ 24-30667-00/0 →Eng.ABS 935 645 →Eng.ADZ 011 565 RP HR816 ■ 24-30653-85/0 Eng.ABS 935 646 → Eng.ADZ 011 566 →	NA5001 32x47x10mm, FPM (50-303185-50) NA5001 ■ 32x47x10mm, FPM (50-303185-50) NA5133 ■ 85x105x11mm, FPM (24-30727-87/0)	HL5020 [245]■ KA5020 [13]	 AY970  BM360  BV850, BV860, BV870  BY630  BZ910  JC152  JC478  JD170  JD281  JD282  JD5235  JD604  JD605  JE160  PA459  HL457  JN914  JN964	
HBS028 Ⓞ [22-39004B] M11x1.50x147mm (x10)	JD281 ■ (31-027904-00) JD282 ■ (x4) (31-026880-00)  (31-025070-00)	HL606 ■ 24-26237-01/0	JJ140 (31-026554-10)	HR816 ■ (x2) 24-30653-85/0	NA5001 32x47x10mm, FPM (50-303185-50) NA5001 ■ 32x47x10mm, FPM (50-303185-50) NA5133 ■ 85x105x11mm, FPM (24-30727-87/0)	HL5020 [245]■	 JD281  JD282  JD5235  JD604  JD605  JE160  PA459	
HBS043 Ⓞ [22-39001B] M11x1.50x95mm (x10)	JC478 ■ 31-026397-00 PA459 ■ 50-024870-00 (NBR) JC152 ■ (x4) 31-026555-00	JN964 50-026423-10	JJ140 (31-026554-10)	HR569 ■ 24-30667-00/0	NA5001 32x47x10mm, FPM (50-303185-50) NA5001 ■ 32x47x10mm, FPM (50-303185-50) NA5133 ■ 85x105x11mm, FPM (24-30727-87/0)	HL5020 [245]■	 JD5235  JD604  JD605  JE160  PA459	
HBS268 Ⓞ [22-33031B] M10x1.50x120mm (x10)	JD604 ■ (31-028824-00) JD605 ■ 31-028826-00	HL732 ■ 24-28815-00/0	HR397 [57] 34-000410-00	HR822 ■	NA5124 (x2) 32x47x10mm, PTFE (50-319433-00) NA5106 ■ 35x48x10mm, PTFE (50-319430-00) LK5003 ■ [3] 85x131x15.7mm, PTFE (50-319434-00)	HL5040 [245]■	 JE160  PA459	
HBS018 Ⓞ [22-39024B] M12x1.75x115mm (x10)	JD170 ■ 31-026556-10 JC152 ■ (x4) 31-026555-00  (31-028373-00)	JN914 50-026557-10 HM5058 ■ 24-26557-00/0	JH5023 (31-029043-00)	HR569 ■ 24-30667-00/0 →Eng.1Y 580 000 HR816 ■ 24-30653-85/0 Eng.1Y 580 000 →	NA5001 32x47x10mm, FPM (50-303185-50) NA5001 ■ 32x47x10mm, FPM (50-303185-50) NA5133 ■ 85x105x11mm, FPM (24-30727-87/0) →Eng.1Y 800 000 LK5006 ■ [3] 85x131x16mm, PTFE (50-319448-00) Eng.1Y 800 001 →	HL5020 [245]■ NA5278 [54]	 HL457  JN914  JN964	



KW/PS



Passat 1.9L TD Diesel				03/91 → 05/97		182	BV850 (MLS), 1.53mm, 1 Hole 30-028545-00 BV860 (MLS), 1.57mm, 2 Holes 30-028546-00 BV870 (MLS), 1.61mm, 3 Holes 30-028547-00		DV850▲ 21-26557-20/0 →Eng.AAZ-678 000 DV851▲ 21-26557-21/0 Eng.AAZ-678 001 →	ECO30 [8] 22-26384-04/0
AAZ	1896	4	79.50			55/75				
Passat 1.9L TDI Diesel				08/98 → 11/00		183	AF5381 (MLS), 1.49mm, 1 Hole 30-030098-10 AF5391 (MLS), 1.57mm, 2 Holes 30-030099-10 AF5401 (MLS), 1.65mm, 3 Holes 30-030100-10		CC5231▲ 21-29463-20/0	EB5370 [8] 22-29314-00/0
Passat 1.9L TDI 4motion Diesel				08/99 → 11/00						
AJM	1896	4	79.50	PDi		85/116				
ATJ	1896	4	79.50			85/116				
Passat 1.9L TDI Diesel				02/00 → 05/05		184	AF5381 (MLS), 1.49mm, 1 Hole 30-030098-10 AF5391 (MLS), 1.57mm, 2 Holes 30-030099-10 AF5401 (MLS), 1.65mm, 3 Holes 30-030100-10		CC5230▲ 21-29463-21/0	EB5370 [8] 22-29314-00/0
Passat 1.9L TDI 4motion Diesel				11/00 → 05/05						
AVB	1896	4	79.50			74/100				
AVF	1896	4	79.50	PDi, SOHC		96/131				
AWX	1986	4	79.50			96/131				
Passat 1.9L TDI Diesel				10/93 → 08/96		185	BX800 (MLS), 1.45mm, 1 Hole 30-028686-00 BX810 (MLS), 1.53mm, 2 Holes 30-028687-00 BX820 (MLS), 1.61mm, 3 Holes 30-028688-00		DX800▲ 21-27921-20/0 →Eng.IZ-720 000 DX801▲ 21-27921-21/0 Eng.IZ-720 001 →	ECO30 [8] 22-26384-04/0
IZ	1896	4	79.50	SOHC		66/89				
Passat 1.9L TDI Diesel				03/05 →		186	AF5381 (MLS), 1.49mm, 1 Hole 30-030098-10 AF5391 (MLS), 1.57mm, 2 Holes 30-030099-10 AF5401 (MLS), 1.65mm, 3 Holes 30-030100-10		CC5230▲ 21-29463-21/0 BKC, BXE	EF5380 22-30369-00/0
BKC	1896	4	79.50			77/105				
BLS/BXE	1896	4	79.50	Direct Injection, SOHC		77/105				
Passat 1.9L TDI Diesel				10/96 → 11/00		187	BX800 (MLS), 1.45mm, 1 Hole 30-028686-00 BX810 (MLS), 1.53mm, 2 Holes 30-028687-00 BX820 (MLS), 1.61mm, 3 Holes 30-028688-00		DX800▲ 21-27921-20/0 AHU DX801▲ 21-27921-21/0 AHH	ECO30 [8] 22-26384-04/0
AHH/AHU	1896	4	79.50			66/89				
Passat 1.9L TDI Diesel				10/96 → 11/00		188	BX800 (MLS), 1.45mm, 1 Hole 30-028686-00 BX810 (MLS), 1.53mm, 2 Holes 30-028687-00 BX820 (MLS), 1.61mm, 3 Holes 30-028688-00		DX800▲ 21-27921-20/0 →Eng.AFN 002 000 DX801▲ 21-27921-21/0 Eng.AFN 002 001 → AVG	ECO30 [8] 22-26384-04/0
Passat 1.9L TDI Syncro / 4motion Diesel				10/96 → 11/00						
AFN	1896	4	79.50	SOHC		81/110				
AVG	1896	4	79.50			81/110				











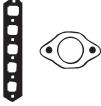

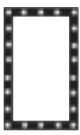

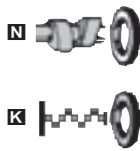









								 BV850, BV860, BV870
HBS018 Ⓞ (22-39024B) M12x1.75x115mm (x10)	JD170 ■ 31-026556-10 JC152 ■ (x4) 31-026555-00	JN914 50-026557-10 HM5058 ■ 24-26557-00/0	JH5023 (31-029043-00)	HR569 ■ 24-30667-00/0 →Eng.AAZ-678 000 HR816 ■ 24-30653-85/0 Eng.AAZ-678 001→	NA5001 ■ 32x47x10mm, FPM (50-303185-50) NA5001 ■ 32x47x10mm, FPM (50-303185-50) NA5133 ■ 85x105x11mm, FPM (24-30727-87/0)	HL5020 [245]■ NA5278 [54]		 BX800, BX810, BX820
HBS300 Ⓞ (22-33034B) M12x1.75x166mm (x10)	JD170 ■ 31-026556-10 JC152 ■ (x4) 31-026555-00	JM5203 50-029934-00	HR397 [57] 34-000410-00	HR816 ■ 24-30653-85/0	NA5124 32x47x10mm, PTFE (50-319433-00) NA5106 ■ 35x48x10mm, PTFE (50-319430-00) LK5003 ■ [3] 85x131x15.7mm, PTFE (50-319434-00)	HL5034 [245]■		 JD600
HBS300 Ⓞ (22-33034B) M12x1.75x166mm (x10)	JD170 ■ 31-026556-10 JD600 ■ 31-028454-00	JM5203 50-029934-00	HR397 [57] 34-000410-00	HR816 ■ 24-30653-85/0	NA5124 32x47x10mm, PTFE (50-319433-00) NA5106 ■ 35x48x10mm, PTFE (50-319430-00) LK5003 ■ [3] 85x131x15.7mm, PTFE (50-319434-00)	HL5034 [245]■		 JN914
HBS018 Ⓞ (22-39024B) M12x1.75x115mm (x10)	JD170 ■ 31-026556-10 JC152 ■ (x4) 31-026555-00	JP003 50-027921-00	JJ609 (50-027500-00) (ACM)	HR569 ■ 24-30667-00/0 →Eng.IZ-720 000 HR816 ■ 24-30653-85/0 Eng.IZ-720 001→	NA5001 32x47x10mm, FPM (50-303185-50) NA5001 ■ 32x47x10mm, FPM (50-303185-50) NA5133 ■ 85x105x11mm, FPM (24-30727-87/0)	HL5020 [245]■ NA5278 [54]		 JD170
HBS300 Ⓞ (22-33034B) M12x1.75x166mm (x10) BKC, BLS	JD170 ■ 31-026556-10 JD600 ■ 31-028454-00 BKC, BXE	JM5203 50-029934-00 BKC, BXE	HR397 [57] 34-000410-00	HR816 ■ 24-30653-85/0	NA5124 32x47x10mm, PTFE (50-319433-00) NA5106 ■ 35x48x10mm, PTFE (50-319430-00) LK5012 ■ [3] [85] 85x132x15.7mm, ACM (50-319535-00)	HL5034 [245]■		 JD600
HBS018 Ⓞ (22-39024B) M12x1.75x115mm (x10)	JD170 ■ 31-026556-10 JC152 ■ (x4) 31-026555-00	JP003 50-027921-00	JJ609 (50-027500-00) (ACM)	HR569 ■ 24-30667-00/0 AHU HR816 ■ 24-30653-85/0 AHH	NA5001 32x47x10mm, FPM (50-303185-50) NA5001 ■ 32x47x10mm, FPM (50-303185-50) NA5133 ■ 85x105x11mm, FPM (24-30727-87/0) →Eng.AHU 390 000 LK5006 ■ [3] 85x131x16mm, PTFE (50-319448-00) Eng.AHU 390 001→ AHH	HL5020 [245]■ NA5278 [54]		 JN914
HBS018 Ⓞ (22-39024B) M12x1.75x115mm (x10)	JD170 ■ 31-026556-10 JC152 ■ (x4) 31-026555-00	JP003 50-027921-00	JJ609 (50-027500-00) (ACM)	HR569 ■ 24-30667-00/0 →Eng.AFN 002 000 HR816 ■ 24-30653-85/0 Eng.AFN 002 001→ AVG	NA5001 32x47x10mm, FPM (50-303185-50) NA5001 ■ 32x47x10mm, FPM (50-303185-50) NA5133 ■ 85x105x11mm, FPM (24-30727-87/0) →Eng.AFN 576 000 LK5006 ■ [3] 85x131x16mm, PTFE (50-319448-00) Eng.AFN 576 000→ AVG	HL5020 [245]■ NA5278 [54]		 JP003

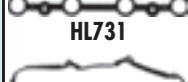

KW/PS



Passat 2.0L		03/95 → 08/96			189	BY750 (MLS)	DY753	EB970
AEP	1984	4	82.50	SOHC	79/107	30-027930-00	21-27930-23/0	22-27500-01/0
Passat 2.0L		11/00 → 05/05			190	AB5370 (MLS)	CB5371	EB5370 [8]
Passat 2.0L 4motion		11/00 → 05/05				30-029314-00		22-29314-00/0
AZM	1984	4	82.50	SOHC	85/116			
Passat 2.0L		11/01 → 05/05			191	AG8810 (MLS)	CG8420	EG9600
ALT	1984	4	82.50	DOHC	96/131	30-030214-00	21-30214-00/0	22-30370-00/0
Passat 2.0L		08/83 → 03/88			192	BM840 (Fibre)	DM840	EX995
Passat 2.0L Syncro		05/84 → 03/88				30-026326-10	(21-26326-22/0)	(22-23856-06/0)
HP/JS	1994	5	81.00		85/115			
Passat 2.0L		02/90 → 05/97			193	BT810 (Fibre)	DT811	EB970
Passat 2.0L Syncro		10/90 → 05/97				30-027257-20	21-27257-22/0	22-27500-01/0
Passat 2.0L Variant		10/93 → 10/96				2E	→Ch.(2E) 31-P-160 000	ADY, AGG
2E	1984	4	82.50	Digifant	85/115	BY750 (MLS)	DY753	ES471
ADY	1984	4	82.50	OHV	85/116	30-027930-00	21-27930-23/0	2E
AGG	1984	4	82.50	SOHC	85/116	ADY, AGG	ADY, AGG	
							DT816	
							21-27257-24/0	
							Ch.(2E) 31-P-160 001 →	
Passat 2.0L 16V		08/88 → 09/93			194	BT810 (Fibre)	DT812	
9A	1984	4	82.50	KE-Motronic	100/136	30-027257-20	21-27257-21/0	
						→Eng.9A 131 460	→Eng.9A 131 460	
						BY750 (MLS)		
						30-027930-00		
						Eng.9A 131 461 →		
Passat 2.0L 16V		01/94 → 05/97			195	BT810 (Fibre)	DT81B	EB970
ABF	1984	4	82.50	Digifant	110/150	30-027257-20	21-27930-20/0	22-27500-01/0
						→Eng.ABF 031 251	Eng.ABF 031 252 →	
						BY750 (MLS)		
						30-027930-00		
						Eng.ABF 031 252 →		
Passat 2.0L FSI		03/05 →			196	AG9600 (MLS)		EG9600
BLR/BLY/BVY/BVZ	1984	4	82.50	Injection, DOHC	110/150	30-030352-00		22-30370-00/0

								
HBS043 Ⓢ [22-39001B] M11x1.50x95mm (x10)	JD483 ■ [31-027352-00] JC152 ■ (x4) 31-026555-00 Ⓢ JF205 [31-025070-00]	JP024 50-027505-00	JJ609 [50-027500-00] (ACM)	HR816 ■ 24-30653-85/0	NA5001 32x47x10mm, FPM [50-303185-50] NA5001 ■ 32x47x10mm, FPM [50-303185-50] NA5133 ■ 85x105x11mm, FPM [24-30727-87/0] LK5006 ■ [3] 85x131x16mm, PTFE [50-319448-00]	HL5020 [245]■		 AB5370  BM840  BT810  BY750  JC152  JC261  JD281  JD282  JD483  JD5341  JD600  JE689  HL460  HL731  JN964  JP024  JJ184  JJ576  JJ609
HBS246 Ⓢ [22-33024B] M10x1.50x120mm (x10)	JD5341 ■ (x4) [50-029940-00] JD600 ■ 31-028454-00	JP024 50-027505-00	HR397 [57] 34-000410-00	HR816 ■ 24-30653-85/0	NA5124 32x47x10mm, PTFE [50-319433-00] NA5106 ■ 35x48x10mm, PTFE [50-319430-00] LK5003 ■ [3] 85x131x15.7mm, PTFE [50-319434-00]	HL5034 [245]■		
	JD5820 ■ (x4) 50-030250-00 JD5813 ■ 31-030233-00	JM7030 [31-030222-00] (Rubber/Metal)	HR397 [57] 34-000410-00	HR822 ■	NA5124 (x2) 32x47x10mm, PTFE [50-319433-00] NA5106 ■ 35x48x10mm, PTFE [50-319430-00] LK5003 ■ [3] 85x131x15.7mm, PTFE [50-319434-00]	HL5040 [245]■		
HBS024 Ⓢ [22-39002B] M11x1.50x95mm (x12)	JC261 ■ [31-026898-00] JC152 ■ (x5) 31-026555-00 Ⓢ JE689 [31-024039-00]	JN438 [50-026864-00] (Rubber) HL460 ■ (Cork) HMS277 ■ 24-26864-00/0 (Rubber)	JJ184 [31-023856-10]	HR615 ■ 24-30667-05/0	NA5001 32x47x10mm, FPM [50-303185-50] NB716 ■ 35x48x10mm, FPM [50-306067-50] NA5133 ■ 85x105x11mm, FPM [24-30727-87/0]	NB567 [2]■		
HBS028 Ⓢ [22-39004B] M11x1.50x147mm (x10) HBS043 Ⓢ [22-39001B] M11x1.50x95mm (x10)	JD483 ■ [31-027352-00] JC152 ■ (x4) 31-026555-00 Ⓢ JF205 [31-025070-00]	JN964 50-026423-10 →Ch.(2E) 31-P-160 000 JP024 50-027505-00 Ch.(2E) 31-P-160 001 → ADY, AGG	JJ576 [50-027808-00] 2E JJ609 [50-027500-00] (ACM) ADY, AGG	HR569 ■ 24-30667-00/0 2E HR816 ■ 24-30653-85/0 ADY, AGG	NA5001 32x47x10mm, FPM [50-303185-50] NA5001 ■ 32x47x10mm, FPM [50-303185-50] LK5006 ■ [3] 85x131x16mm, PTFE [50-319448-00] NA5133 ■ 85x105x11mm, FPM [24-30727-87/0]	HL5020 [245]■ NA5278 [54]		
HBS028 Ⓢ [22-39004B] M11x1.50x147mm (x10) →Eng.9A 131 460	JD281 ■ [31-027904-00] JD282 ■ (x4) [31-026880-00] Ⓢ JF205 [31-025070-00]	HL606 ■ 24-26237-01/0	JJ576 [50-027808-00]	HR816 ■ (x2) 24-30653-85/0	NA5001 32x47x10mm, FPM [50-303185-50] NA5001 ■ 32x47x10mm, FPM [50-303185-50] NA5133 ■ 85x105x11mm, FPM [24-30727-87/0]	HL5020 [245]■		
HBS028 Ⓢ [22-39004B] M11x1.50x147mm (x10) →Eng.ABF 031 251	JD281 ■ [31-027904-00] JD282 ■ (x4) [31-026880-00] Ⓢ JF205 [31-025070-00]	HL606 ■ 24-26237-01/0 →Eng.ABF 031 251 HL731 ■ 24-27937-00/0 Eng.ABF 031 252 →	JJ609 [50-027500-00] (ACM)	HR816 ■ (x2) 24-30653-85/0	NA5001 32x47x10mm, FPM [50-303185-50] NA5001 ■ 32x47x10mm, FPM [50-303185-50] NA5133 ■ 85x105x11mm, FPM [24-30727-87/0]	HL5020 [245]■		
HBS363 Ⓢ [22-33038B] M10x1.50x122mm (x10)	JD5873 ■ 50-030353-00 (FPM) JD5813 ■ 31-030233-00		HR397 [57] 34-000410-00	HR791 ■ 24-30614-76/0	NA5124 32x47x10mm, PTFE [50-319433-00] NA5106 ■ 35x48x10mm, PTFE [50-319430-00] LK5008 ■ [3] 85x131x15.7mm, PTFE [50-319472-00]	HL5034 [245]■		



KW/PS



Passat 2.0L FSI						08/05 →	197	AG9600 (MLS)		EG9600
Passat 2.0L FSI 4motion						09/05 →		30-030352-00		22-30370-00/0
BLR	1984	4	82.50	Injection, DOHC			110/150			
BLX	1984	4	82.50				110/150			
BLY/BVX/BVY/BVZ	1984	4	82.50	Injection, DOHC			110/150			
Passat 2.0L TDI Diesel						12/03 →05/05	198	AG9630 (MLS), 1.45mm, 1 Hole	CC5230▲	EB5370 [8]
BGW	1968	4	81.00	Direct Injection, DOHC			100/136	30-030349-00 AG9640 (MLS), 1.53mm, 2 Holes AG9650 (MLS), 1.61mm, 3 Holes	21-29463-21/0	22-29314-00/0
Passat 2.0L TDI Diesel						08/05 →	199	AG8970 (MLS), 1.55mm, 1 Hole		EF5380
BMR	1968	4	81.00	Direct Injection, DOHC			125/170	30-030249-00 AG8800 (MLS), 1.63mm, 2 Holes (30-030213-00) AG8960 (MLS), 1.71mm, 3 Holes (30-030248-00)		22-30369-00/0
Passat 2.0L TDI Diesel						03/05 →07/06	200	AG8970 (MLS), 1.55mm, 1 Hole		EF5380
Passat 2.0L TDI 16V Diesel						03/05 →		30-030249-00		22-30369-00/0
BVD/BVE	1968	4	81.00	Direct Injection, DOHC			90/122	AG8800 (MLS), 1.63mm, 2 Holes (30-030213-00)		
BMA	1968	4	81.00	Direct Injection, DOHC			100/136	AG8960 (MLS), 1.71mm, 3 Holes (30-030248-00)		
BKP	1968	4	81.00	Direct Injection, DOHC			103/140			
Passat 2.0L TDI Diesel						03/05 →	201	AG9630 (MLS), 1.45mm, 1 Hole		EF5380
Passat 2.0L TDI 4motion Diesel						03/05 →		30-030349-00		22-30369-00/0
Passat 2.0L TDI 4motion Variant Diesel						08/05 →		AG9640 (MLS), 1.53mm, 2 Holes		
Passat 2.0L TDI Variant Diesel						08/05 →		AG9650 (MLS), 1.61mm, 3 Holes		
BMP	1968	4	81.00	Direct Injection, DOHC			103/140			
Passat 2.2L						01/85 →03/88	202	BM840 (Fibre)	DM840	EX995
Passat 2.2L Syncro						08/85 →03/88		30-026326-10	(21-26326-22/0)	(22-23856-06/0)
Passat 2.2L Variant						01/85 →03/88				
KX	2226	5	81.00				85/116			
JT	2226	5	81.00				88/120			
KV	2226	5	81.00				100/136			
Passat 2.3L V5						11/00 →05/05	203		CG9621	EG5010
Passat 2.3L VR5						11/00 →05/05			21-30348-10/0	
AZX	2324	5	81.00	V5			125/170			
Passat 2.3L VR5						10/96 →11/00	204	AG7800	CG7800	EG7800
Passat 2.3L VR5 Syncro / 4motion						10/97 →11/00				
AGZ	2324	5	81.00	DOHC, V5			110/150			
Passat 2.5L TDI Diesel						07/98 →05/05	205	AC5960 (MLS), 1.10mm, 1 Hole (x2)	CC5960▲	
Passat 2.5L TDI 4motion Diesel						11/00 →05/05		30-029397-00	21-29397-00/0	
Passat 2.5L TDI Syncro / 4motion Diesel						12/98 →11/00		AC5970 (MLS), 1.15mm, 2 Holes (x2)		
AFB/AKN	2496	6	78.30	DOHC, V6			110/150	30-029398-00 AC5980 (MLS), 1.20mm, 3 Holes (x2) 30-029399-00		
Passat 2.5L TDI Diesel						05/03 →05/05	206	AC5960 (MLS), 1.10mm, 1 Hole (x2)	CC5960▲	
Passat 2.5L TDI 4motion Diesel						01/03 →05/05		30-029397-00	21-29397-00/0	
BDG	2496	6	78.30	DOHC, V6			120/163	AC5970 (MLS), 1.15mm, 2 Holes (x2)		
BAU/BDH	2496	6	78.30	DOHC, V6			132/180	30-029398-00 AC5980 (MLS), 1.20mm, 3 Holes (x2) 30-029399-00		

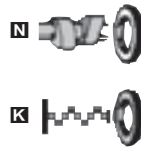
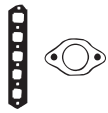

AC5960, AC5970,
AC5980



BM840



JC152



JC261



JD170



JD600



HL460



JJ184











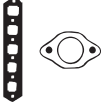

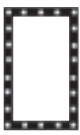































































HBS363 Ⓢ (22-33038B) M10x1.50x122mm (x10)	JD5873 ■ 50-030353-00 (FPM) JD5813 ■ 31-030233-00		HR397 [57] 34-000410-00	HR791 ■ 24-30614-76/0	NA5124 32x47x10mm, PTFE (50-319433-00) NA5106 ■ 35x48x10mm, PTFE (50-319430-00) LK5008 ■ [3] 85x131x15.7mm, PTFE (50-319472-00)	HL5034 [245] ■
HBS300 Ⓢ (22-33034B) M12x1.75x166mm (x10)	JD170 ■ 31-026556-10 JD600 ■ 31-028454-00	JM5203 50-029934-00	HR397 [57] 34-000410-00	HR816 ■ 24-30653-85/0	NA5124 32x47x10mm, PTFE (50-319433-00) NA5106 ■ 35x48x10mm, PTFE (50-319430-00) LK5003 ■ [3] 85x131x15.7mm, PTFE (50-319434-00)	HL5034 [245] ■
HBS364 Ⓢ (22-39032B) M12x1.75x149mm (x10)	JD5805 ■ 50-030225-00 JD5806 ■ 31-030226-00		HR397 [57] 34-000410-00	HR791 ■ 24-30614-76/0	NA5124 32x47x10mm, PTFE (50-319433-00) NA5106 ■ 35x48x10mm, PTFE (50-319430-00) LK5012 ■ [3] [85] 85x132x15.7mm, ACM (50-319535-00)	
HBS364 Ⓢ (22-39032B) M12x1.75x149mm (x10)	JD5805 ■ 50-030225-00 JD5806 ■ 31-030226-00 JD5815 ■ 31-030235-00	JM7031 50-030223-00 (Rubber)	HR397 [57] 34-000410-00	HR791 ■ 24-30614-76/0	NA5124 32x47x10mm, PTFE (50-319433-00) NA5106 ■ 35x48x10mm, PTFE (50-319430-00) LK5012 ■ [3] [85] 85x132x15.7mm, ACM (50-319535-00)	KK5522 [86]
HBS300 Ⓢ (22-33034B) M12x1.75x166mm (x10)	JD170 ■ 31-026556-10		HR397 [57] 34-000410-00	HR816 ■ 24-30653-85/0	NA5124 32x47x10mm, PTFE (50-319433-00) NA5106 ■ 35x48x10mm, PTFE (50-319430-00) LK5012 ■ [3] [85] 85x132x15.7mm, ACM (50-319535-00)	
HBS024 Ⓢ (22-39002B) M11x1.50x95mm (x12)	JC261 ■ (31-026898-00) JC152 ■ (x5) 31-026555-00	JN438 (50-026864-00) (Rubber) HL460 ■ (Cork) HM5277 ■ 24-26864-00/0 (Rubber)	JJ184 (31-023856-10)	HR615 ■ 24-30667-05/0	NA5001 32x47x10mm, FPM (50-303185-50) NB716 ■ 35x48x10mm, FPM (50-306067-50) NA5133 ■ 85x105x11mm, FPM (24-30727-87/0)	NB567 [2] ■
		JM5234 (50-029982-00)	HR397 [57] 34-000410-00	HR822 ■	NA5106 ■ 35x48x10mm, PTFE (50-319430-00)	
HBS461 (22-39034B)			HR397 [57] 34-000410-00		NA5106 ■ 35x48x10mm, PTFE (50-319430-00)	
HBS265 Ⓢ (22-33027B) M12x1.50x155mm (x16)	JD5810 ■ (x2) (31-030230-00) JD5851 ■ (x6) 31-030293-00 (Fibre)	HM5223 ■ (x2) 24-30020-00/0 (ACM)		HR5062 ■ 24-30614-73/0	NA5001 (x2) 32x47x10mm, FPM (50-303185-50) NB716 ■ 35x48x10mm, FPM (50-306067-50)	
HBS361 Ⓢ (22-33037B) M12x1.50x159mm (x16)	JD5810 ■ (x2) (31-030230-00) JD5851 ■ (x6) 31-030293-00 (Fibre)	HM5223 ■ (x2) 24-30020-00/0 (ACM)	HR397 [57] 34-000410-00	HR5062 ■ 24-30614-73/0	NA5001 (x2) 32x47x10mm, FPM (50-303185-50) NB716 ■ 35x48x10mm, FPM (50-306067-50)	



KW/PS



Passat 2.8L VR6				06/91 → 05/97	207	AA5430 (Fibre)	CA5430	EC340
AAA	2792	6	81.00	Injection, DOHC, V6	128/174	30-027920-00	21-27920-20/0 →Eng.AAA 146 000	(22-28817-00/0) Eng.AAA 146 001 →
Passat 2.9L VR6 Syncro				01/94 → 05/97	208	AA5430 (Fibre)	CA5430	EC340
ABV	2861	6	82.00	DOHC, V6	140/190	30-027920-00	21-27920-20/0 →Eng.ABV 023 000	(22-28817-00/0) Eng.ABV 023 001 →
Phaeton 3.0L V6 TDI 4motion Diesel				09/04 →	209	AG8880 (MLS), 1.1mm, 1 Hole [87] 30-030240-00 AG8900 (MLS), 1.1mm, 1 Hole [88] 30-030242-00 AG8860 (MLS), 1.15mm, 2 Holes [87] 30-030219-00 AG8870 (MLS), 1.15mm, 2 Holes [88] 30-030220-00 AG8890 (MLS), 1.2mm, 3 Holes [87] 30-030241-00 AG8910 (MLS), 1.2mm, 3 Holes [88] 30-030243-00		
BMK	2967	6	83.00	Direct Injection, DOHC, V6	165/224			
Phaeton 3.2L V6				04/02 →	210	AG9610 (MLS) 30-030350-00	CG9610 21-30350-00/0	EG5010
Phaeton 3.2L V6 4motion				02/04 →				
AYT	3189	6	84.00	V6	177/240			
BKL/BRK	3189	6	84.00	DOHC, V6	177/240			
Polo 1.0L				10/99 → 09/01	211	AD5630 (MLS), 0.50mm 30-029660-00	CD5630 21-29660-00/0	
ALD	999	4	67.10	Motronic, SOHC	37/50			
AUC	999	4	67.10		37/50			
Polo 1.0L				01/85 → 09/94	212	BL570 (Fibre), 1.73mm 30-024813-20	DL572 21-24813-25/0 →Ch.80-N-500 000 DL574 21-24813-27/0 Ch.80-P-000 001 →	EV460 22-26516-01/0
Polo 1.0				08/89 → 09/94				
Polo Coupe 1.0				08/89 → 09/94				
Polo Van 1.0L				04/93 → 12/99				
AAK	1043	4	75.00	SOHC	33/44			
AAU	1043	4	75.00	Monomotronic	33/44			
ACM	1043	4	75.00		33/44			
HZ	1043	4	75.00		33/37/ 45/50			
Polo 1.0L				08/85 → 01/92	213	BL570 (Fibre), 1.73mm 30-024813-20	DL572 21-24813-25/0	EV460 22-26516-01/0
Polo Coupe 1.0L				08/85 → 01/92				
HZ	1043	4	75.00		33/37/ 45/50			
Polo 1.0L 45				10/94 → 09/96	214	BL570 (Fibre), 1.73mm 30-024813-20	DL573 (21-24813-28/0)	EB961 [8] 22-28897-03/0
AEV	1043	4	75.00		33/45			











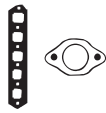

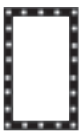

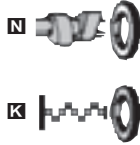

								 AA5430  AD5630  BL570  JA5068  JA5069  JC259  JD246  JD488  JD5109  JD5232  JD5318  JD597  JE154  JM5030  JM5099  JN641  JP074  JH5013  JH5059  JJ183
HBS077  [22-39012B] M11x1.50x85mm (x7) M11x1.50x144mm (x3) M11x1.50x119mm (x10)	JD5232  [31-027918-00] JA5068  [31-027917-00] JA5069  [28] [31-027913-00] JD5109  [29] [31-027914-00]	JM5030 50-027915-00 →Eng.AAA 146 000 JM5099 50-029103-00 Eng.AAA 146 001→	JH5013 [31-027911-00] →Eng.AAA 146 000 JH5059 [50-028817-00] Eng.AAA 146 000→	HR602  24-30670-61/0	NA5133  85x105x11mm, FPM [24-30727-87/0]			
HBS077  [22-39012B] M11x1.50x85mm (x7) M11x1.50x144mm (x3) M11x1.50x119mm (x10)	JD5232  [31-027918-00] JA5068  [31-027917-00] JA5069  [28] [31-027913-00] JD5109  [29] [31-027914-00]	JM5030 50-027915-00 →Eng.ABV 023 000 JM5099 50-029103-00 Eng.ABV 023 001→	JH5013 [31-027911-00] →Eng.ABV 023 000 JH5059 [50-028817-00] Eng.ABV 023 001→	HR602  24-30670-61/0	NA5133  85x105x11mm, FPM [24-30727-87/0]			
HBS361  [22-33037B] M12x1.50x159mm (x16)	JD5872  (x2) 50-030355-00 (ACM)	JM7046 [87] 50-030356-00 (ACM) JM7047 [88] 50-030357-00 (ACM)	HR397 [57] 34-000410-00	HR5062  24-30614-73/0	NA5001 (x2) 32x47x10mm, FPM [50-303185-50]			
HBS466 [22-33039B]	JD5874  50-030351-00 (FPM)	JM7045 50-030133-00 (Rubber)	HR397 [57] 34-000410-00	HR5062  24-30614-73/0	NA5106  35x48x10mm, PTFE [50-319430-00]			
HBS362  [22-39031B] M9x1.25x162mm (x10)	JD597  50-350355-00 JD5318  [31-029901-00] JE5076   [31-028373-00]			HR817  24-30614-78/0	NA5185 32x42x6mm, FPM [50-319489-00] NA5185  32x42x6mm, FPM [50-319489-00] LK5011  [3] [78] 85x131x15.94mm, PTFE	KA5025 [13]		
HBS043  [22-39001B] M11x1.50x95mm (x10)	JD246  [31-026474-20] JC259  (x2) 31-026229-10	JN641 50-025265-10	JJ183 [31-026516-10]	HR569  24-30667-00/0 →Ch.80-N-500 000 HR816  24-30653-85/0 Ch.80-P-000 001→	NA5001 32x47x10mm, FPM [50-303185-50] NA5001  32x47x10mm, FPM [50-303185-50] NA5133  85x105x11mm, FPM [24-30727-87/0]	HL5020 [245] 		
HBS043  [22-39001B] M11x1.50x95mm (x10)	JD246  [31-026474-20] JC259  (x2) 31-026229-10		JJ183 [31-026516-10]	HR569  24-30667-00/0	NA5001 32x47x10mm, FPM [50-303185-50] NA5001  32x47x10mm, FPM [50-303185-50] NA5133  85x105x11mm, FPM [24-30727-87/0]	HL5020 [245] 		
HBS043  [22-39001B] M11x1.50x95mm (x10)	JD246  [31-026474-20] JD488  31-027909-00	JP074 50-027907-00 HM5062  24-27907-00/0	HR397 [57] 34-000410-00	HR816  24-30653-85/0	NA5001 32x47x10mm, FPM [50-303185-50] NA5001  32x47x10mm, FPM [50-303185-50] NA5133  85x105x11mm, FPM [24-30727-87/0]	HL5020 [245] 		



KW/PS



Polo 1.0L 50					09/96 → 10/99	215	AA5410 (MLS), 0.60mm	CA5410	EB961 [8]
AER/ALL	999	4	67.10	Injection, SOHC		37/50	30-029052-10	21-29052-20/0	22-28897-03/0
Polo 1.1L					10/81 → 09/89	216	BL560 (Fibre), 1.70mm	DL561	EA900
Polo Coupe 1.1L					10/81 → 07/83		(30-023518-20)	(21-24853-22/0)	(22-26516-00/0)
HB	1093	4	69.50			37/50			
Polo 1.2L					10/01 →	217	AF5990 (MLS)	CF5990	EF5990
AZQ	1198	3	76.50	DOHC		47/64	(30-030120-00)	21-30120-00/0	22-30371-00/0
BME	1198	3	76.50	SOHC		47/64			
BZG	1198	3	76.50	Injection, DOHC		51/69			
Polo 1.2L					04/01 → 10/01	218	AG8840 (MLS)	CG8840	EF5990
AWY/BMD	1198	3	76.50	SOHC		40/54	(30-030217-00)	21-27217-00/0 → Ch.9N-5-044 100 → Ch.9N-5Y-138 500	22-30371-00/0
Polo 1.3L					07/87 → 09/94	219	BL570 (Fibre), 1.73mm	DL572	EV460
Polo Coupe 1.3L					07/87 → 09/94		30-024813-20	21-24813-25/0	22-26516-01/0
Polo Van 1.3L					04/93 →			→ Ch.80-N-500 000	
2G	1272	4	75.00	SOHC		40/54		DL574	
AAV	1272	4	75.00	Monomotronic		40/54		21-24813-27/0	
MH	1272	4	75.00	SOHC		40/54		Ch.80-P-000 801 →	
NZ	1272	4	75.00			40/54			
3F	1272	4	75.00	Digifant		55/57/ 75/78			
Polo 1.3L					09/82 → 09/89	220	BL570 (Fibre), 1.73mm	DL570	EA900
Polo Coupe 1.3L					09/82 → 09/89		30-024813-20	21-24813-24/0	(22-26516-00/0)
HW	1272	4	75.00	Carburettor, SOHC		37/50			
GK	1272	4	75.00			55/75			
Polo 1.3L					08/83 → 07/88	221	BL570 (Fibre), 1.73mm	DL570	EA900
Polo Coupe 1.3L					08/83 → 06/87		30-024813-20	21-24813-24/0	(22-26516-00/0)
HK	1272	4	75.00			40/54		HK	HK
MH	1272	4	75.00	SOHC		40/54		DL572	EV460
								21-24813-25/0	22-26516-01/0
								MH	MH

								
HBS249 Ⓢ (22-33025B) M9x1.25x138mm (x10)	JD597 ■ ■ 50-350355-00 JD601 ■ 31-028644-00	JP074 50-027907-00 HM5062 ■ 24-27907-00/0	HR397 [57] 34-000410-00	HR816 ■ 24-30653-85/0	NA5001 32x47x10mm, FPM (50-303185-50) NA5001 ■ 32x47x10mm, FPM (50-303185-50) →Eng.AER 220 083 NA5133 ■ 85x105x11mm, FPM (24-30727-87/0) →Eng.AER 220 083 NA5185 ■ 32x42x6mm, FPM (50-319489-00) Eng.AER 220 084→ ALL LK5006 ■ [3] 85x131x16mm, PTFE (50-319448-00) Eng.AER 220 084→ ALL	HL5020 [245]■	 AA5410  BL560  BL570  JC259  JD246  JD597  JD601	
HBS043 Ⓢ (22-39001B) M11x1.50x95mm (x10)	JD246 ■ (31-026474-20) JC259 ■ (x2) 31-026229-10	JM154 31-024942-10	JJ183 (31-026516-10)	HR569 ■ 24-30667-00/0	NA5001 32x47x10mm, FPM (50-303185-50) NA5001 ■ 32x47x10mm, FPM (50-303185-50) NA5133 ■ 85x105x11mm, FPM (24-30727-87/0)	HL5020 [245]■	 JM154  JN641	
HBS471 Ⓢ (22-39035B) M9x1.25x138mm (x8)	JD5811 ■ (x3) (50-030231-00) JD5816 ■ 31-030236-00	HR397 [57] 34-000410-00	HR397 [57] 34-000410-00	HR280 ■ 24-30614-75/0	NA5106 ■ 35x48x10mm, PTFE (50-319430-00)		 JP074  JJ183	
HBS479 Ⓢ (22-39036B) M9x1.25x162mm (x8)	JD5807 ■ (x3) 50-030227-00 →Ch.9N-5-044 100 →Ch.9N-5Y-138 500 JD5808 ■ (x3) 50-030228-00 Ch.9N-5-044 101→ Ch.9N-5Y-138 501→ JD5819 ■ 31-030239-00	HR397 [57] 34-000410-00	HR397 [57] 34-000410-00	HL5002 ■ (24-30614-77/0)	NA5106 ■ 35x48x10mm, PTFE (50-319430-00)			
HBS043 Ⓢ (22-39001B) M11x1.50x95mm (x10)	JD246 ■ (31-026474-20) JC259 ■ (x2) 31-026229-10	JN641 50-025265-10	JJ183 (31-026516-10)	HR569 ■ 24-30667-00/0 →Ch.80-N-500 HR816 ■ 24-30653-85/0 Ch.80-P-000 801→	NA5001 32x47x10mm, FPM (50-303185-50) NA5001 ■ 32x47x10mm, FPM (50-303185-50) NA5133 ■ 85x105x11mm, FPM (24-30727-87/0)	HL5020 [245]■		
HBS043 Ⓢ (22-39001B) M11x1.50x95mm (x10)	JD246 ■ (31-026474-20) JC259 ■ (x2) 31-026229-10	JM154 31-024942-10	JJ183 (31-026516-10)	HR569 ■ 24-30667-00/0	NA5001 32x47x10mm, FPM (50-303185-50) NA5001 ■ 32x47x10mm, FPM (50-303185-50) NA5133 ■ 85x105x11mm, FPM (24-30727-87/0)	HL5020 [245]■		
HBS043 Ⓢ (22-39001B) M11x1.50x95mm (x10)	JD246 ■ (31-026474-20) JC259 ■ (x2) 31-026229-10	JM154 31-024942-10 HK JN641 50-025265-10 MH	JJ183 (31-026516-10)	HR569 ■ 24-30667-00/0	NA5001 32x47x10mm, FPM (50-303185-50) NA5001 ■ 32x47x10mm, FPM (50-303185-50) NA5133 ■ 85x105x11mm, FPM (24-30727-87/0)	HL5020 [245]■		











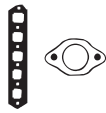

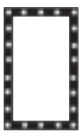

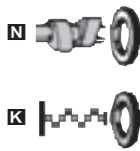











VW



KW/PS



Polo 1.3L 55					10/94 → 07/95	222	BZ180 (MLS), 0.50mm	DZ180	EB961 [8]
ADX	1296	4	76.50	SPi, SOHC		40/54	30-027910-10	21-27910-20/0	22-28897-03/0
Polo 1.3L D Diesel					08/86 → 07/90	223	BV460 (Fibre), 1.53mm, 1 Notch	DV460▲	EV460
Polo Coupe 1.3L D Diesel					08/86 → 08/90		30-027103-00	21-25265-21/0	22-26516-01/0
MN	1272	4	75.00			33/44	BV470 (Fibre), 1.57mm, 2 Notches 30-027104-00 BV480 (Fibre), 1.61mm, 3 Notches 30-027105-00		
Polo Coupe 1.3L G40					01/87 → 09/94	224	AY930 (Fibre)	CY930	EV460
PY	1272	4	75.00	Digifant		85/115	(30-027925-00)	21-27925-20/0	22-26516-01/0
Polo 1.4L					07/03 →	225	AB5701 (MLS)	CB5700☒	EB5700 [8]
Polo 1.4L 16V					10/99 → 09/01		30-029313-10	21-29313-20/0	22-29313-00/0
Polo 1.4L 16V 75					10/99 → 09/01				
AHW	1390	4	76.50			55/75			
APE	1390	4	76.50	MPi, DOHC		55/75			
AUA	1390	4	76.50	MPi, SOHC		55/75			
BBY	1390	4	76.50			55/75			
BKY	1390	4	76.50	DOHC		55/75			
BUD	1390	4	76.50	Injection, DOHC		59/80			
AFK	1390	4	76.50	MPi, DOHC		74/100			
AQQ	1390	4	76.50	DOHC		74/100			
AUB	1390	4	76.50	MPi, DOHC		74/100			
BBZ	1390	4	76.50	DOHC		74/100			
Polo 1.4L					05/97 → 09/01	226	BZ180 (MLS), 0.50mm	CD5640☒	EB961 [8]
Polo 1.4L 60					12/95 → 09/01		30-027910-10	21-29662-20/0	22-28897-03/0
AEX	1390	4	76.50	Injection, SOHC		40/44/ 54/60	AEX, AKV, APQ	AKK, ANW, AUD	AEX, AKV, APQ
AKK	1390	4	76.50	Motronic, SOHC		44/60	AD5640 (MLS), 0.64mm	DZ181	
AKV	1390	4	76.50	SOHC		44/60	30-029662-00	21-27910-21/0	
ANW	1390	4	76.50	MPi, SOHC		44/60	AKK, ANW, AUD	AEX, AKV, APQ	
APQ/AUD	1390	4	76.50	SOHC		44/60			

								
HBS075 Ⓞ (22-39011B) M11x1.50x110mm (x10)	JD487 ■ (31-027908-00) JD488 ■ 31-027909-00	JP074 50-027907-00 HM5062 ■ 24-27907-00/0	HR397 [57] 34-000410-00	HR816 ■ 24-30653-85/0	NA5001 32x47x10mm, FPM (50-303185-50) NA5001 ■ 32x47x10mm, FPM (50-303185-50) NA5133 ■ 85x105x11mm, FPM (24-30727-87/0)	HL5020 [245]■		 AD5640  AY930  BV460, BV470, BV480  BZ180  JC259
HBS018 Ⓞ (22-39024B) M12x1.75x115mm (x10)	JD246 ■ (31-026474-20) JC259 ■ (x2) 31-026229-10	JN641 50-025265-10	JJ183 (31-026516-10)	HR569 ■ 24-30667-00/0	NA5001 (x2) 32x47x10mm, FPM (50-303185-50) NA5001 ■ 32x47x10mm, FPM (50-303185-50) NA5133 ■ 85x105x11mm, FPM (24-30727-87/0)	HL5020 [245]■ NB567 [2]■		 JC259  JD246  JD487  JD488
HBS043 Ⓞ (22-39001B) M11x1.50x95mm (x10)	JD246 ■ (31-026474-20) JC259 ■ (x2) 31-026229-10	JP075 (50-027927-00)	JJ183 (31-026516-10)	HR816 ■ 24-30653-85/0	NA5001 ■ 32x47x10mm, FPM (50-303185-50) NA5001 ■ 32x47x10mm, FPM (50-303185-50) NA5133 ■ 85x105x11mm, FPM (24-30727-87/0)	HL5020 [245]■		 JD246  JD487  JD488
HBS249 Ⓞ (22-33025B) M9x1.25x138mm (x10)	JD5228 ■ (x4) (50-029071-00) JD5298 ■ (31-029825-00)	HR397 [57] 34-000410-00	HR397 [57] 34-000410-00	HR791 ■ 24-30614-76/0	NA5180 27x42x8mm, FPM (50-319484-00) NA5185 ■ 32x42x6mm, FPM (50-319489-00)	KA5025 [13] KK5551 [81]		 JD5228  JD5298  JD5318  JD597
HBS075 Ⓞ (22-39011B) M11x1.50x110mm (x10) AEX, AKV, APQ HBS362 Ⓞ (22-39031B) M9x1.25x162mm (x10) AKK, ANW, AUD	JD597 ■ ■ 50-350355-00 JD5318 ■ (31-029901-00) AKK, ANW, AUD JD601 ■ 31-028644-00 AEX, AKV, APQ	JP074 50-027907-00 AEX, AKV, APQ HM5062 ■ 24-27907-00/0 AEX, AKV, APQ	HR397 [57] 34-000410-00	HR816 ■ 24-30653-85/0 AEX, AKV, APQ HR817 ■ 24-30614-78/0 AKK, ANW, AUD	NA5001 32x47x10mm, FPM (50-303185-50) AEX, AKV, APQ NA5185 32x42x6mm, FPM (50-319489-00) AKK, ANW, AUD NA5001 ■ 32x47x10mm, FPM (50-303185-50) →Eng.AEX 908 121 →Eng.AKV 095 009 NA5133 ■ 85x105x11mm, FPM (24-30727-87/0) →Eng.AEX 908 121 →Eng.AKV 095 009 LK5011 ■ [3] [78] 85x131x15.94mm, PTFE AKK, ANW, AUD NA5185 ■ 32x42x6mm, FPM (50-319489-00) Eng.AEX 908 122→ Eng.AKV 095 010→ AKK, ANW, APQ, AUD LK5006 ■ [3] 85x131x16mm, PTFE (50-319448-00) Eng.AEX 908 122→ Eng.AKV 095 010→ APQ	HL5020 [245]■ →Eng.AEX 908 121 →Eng.AKV 095 009		 JD601  JN641  JP074  JP075  JJ183











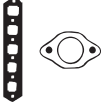

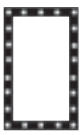

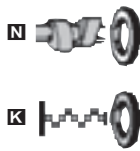













































































VW



KW/PS



Polo 1.4L 16V 100				04/96 → 10/99		227	AA5500 (MLS)	CA5500	EB961 [8]
AFH	1390	4	76.50			74/100	30-029042-00	21-29042-20/0	22-28897-03/0
Polo 1.4L 55				08/95 → 10/99		228	BZ180 (MLS), 0.50mm	DZ181	EB961 [8]
AEX	1390	4	76.50	Injection, SOHC		40/44/ 54/60	30-027910-10	21-27910-21/0	22-28897-03/0
Polo 1.4L D Diesel				10/90 → 09/94		229	BV460 (Fibre), 1.53mm, 1 Notch	DV460▲	EV460
Polo Coupe 1.4L D Diesel				08/90 → 09/94			30-027103-00	21-25265-21/0	22-26516-01/0
Polo Van 1.4L D Diesel				04/93 →			BV470 (Fibre), 1.57mm, 2 Notches	→ Ch.80-NW-500 000	
1W	1398	4	75.00			35/47	30-027104-00		
							BV480 (Fibre), 1.61mm, 3 Notches		
							30-027105-00		
Polo 1.4L FSI				05/02 →		230	AG8850 (MLS)	CG8850	
AXU	1390	4	76.50	DOHC		63/86	(30-030218-00)	21-30218-00/0	
Polo 1.4L TDI Diesel				10/99 → 09/01		231	AD5650 (MLS), 1.45mm, 1 Hole	CD5650▲	ED5650 [8]
BNM/BWB	1422	3	79.50	Direct Injection, SOHC		51/70	30-029663-00	21-29671-20/0	(22-29671-00/0)
AMF	1422	3	79.50	PDi, SOHC		55/75	AD5660 (MLS), 1.53mm, 2 Holes		
BAY	1422	3	79.50			55/75	30-029664-00		
BMS/BNV	1422	3	79.50	Direct Injection, SOHC		59/80	AD5670 (MLS), 1.61mm, 3 Holes		
							30-029665-00		
Polo 1.6L				05/97 → 09/01		232	BZ180 (MLS), 0.50mm	DZ181	EB961 [8]
Polo 1.6L 75				11/95 → 09/01			30-027910-10	21-27910-21/0	22-28897-03/0
AEE	1598	4	76.50	Injection, SOHC		55/75			
ALM	1598	4	76.50			55/75			

								
		JD5228  (x4) (50-029071-00) JD5233  (31-028590-00)		HR397 [57] 34-000410-00	HR791  24-30614-76/0	 NA5001 (x2) 32x47x10mm, FPM (50-303185-50)  NA5001  32x47x10mm, FPM (50-303185-50)  NA5133  85x105x11mm, FPM (24-30727-87/0) →Eng.AFH 030 000  LK5006  [3] 85x131x16mm, PTFE (50-319448-00) Eng.AFH 030 001→	HL5020 [245] 	 AA5500  AD5650, AD5660, AD5670  BV460, BV470, BV480  BZ180
HBS075  (22-39011B) M11x1.50x110mm (x10)	JD597    50-350355-00 JD601  31-028644-00	JP074 50-027907-00 HM5062  24-27907-00/0	HR397 [57] 34-000410-00	HR816  24-30653-85/0	 NA5001 32x47x10mm, FPM (50-303185-50)  NA5001  32x47x10mm, FPM (50-303185-50) →Eng.AEX 908 121  NA5133  85x105x11mm, FPM (24-30727-87/0) →Eng.AEX 908 121  NA5185  32x42x6mm, FPM (50-319489-00) Eng.AEX 908 122→  LK5006  [3] 85x131x16mm, PTFE (50-319448-00) Eng.AEX 908 122→	HL5020 [245]  →Eng.AEX 908 121	 JC259  JD246  JD5228  JD5233  JD5278	
HBS018  (22-39024B) M12x1.75x115mm (x10)	JD246  (31-026474-20) JC259  (x2) 31-026229-10	JN641 50-025265-10	JJ183 (31-026516-10)	HR569  24-30667-00/0 →Ch.80-NW- 500 00 HR816  24-30653-85/0 Ch.80-PW-000 001→	 NA5001 (x2) 32x47x10mm, FPM (50-303185-50)  NA5001  32x47x10mm, FPM (50-303185-50)  NA5133  85x105x11mm, FPM (24-30727-87/0)	HL5020 [245] 	 JD5279  JD597  JD601	
HBS249  (22-33025B) M9x1.25x138mm (x10)	JD5809  31-030229-00 JD5814  31-030234-00	HR397 [57] 34-000410-00	HR397 [57] 34-000410-00	HR791  24-30614-76/0	 NA5106  35x48x10mm, PTFE (50-319430-00)		 JN641	
HBS264  (22-33026B) M12x1.75x166mm (x8)	JD5278  (31-029671-00) JD5279  (31-029710-00)	JM7032 50-030224-00	HR397 [57] 34-000410-00	HR5068  (24-30653-84/0)	 NA5124 32x47x10mm, PTFE (50-319433-00)  NA5106  35x48x10mm, PTFE (50-319430-00)  LK5003  [3] 85x131x15.7mm, PTFE (50-319434-00)	HL5034 [245] 	 JP074  JJ183	
HBS075  (22-39011B) M11x1.50x110mm (x10)	JD597   50-350355-00 JD601  31-028644-00	JP074 50-027907-00 HM5062  24-27907-00/0	HR397 [57] 34-000410-00	HR816  24-30653-85/0	 NA5001 32x47x10mm, FPM (50-303185-50)  NA5001  32x47x10mm, FPM (50-303185-50) →Eng.AEE 562 757 →Eng.ALM 000 706  NA5133  85x105x11mm, FPM (24-30727-87/0) →Eng.AEE 562 757 →Eng.ALM 000 706  NA5185  32x42x6mm, FPM (50-319489-00) Eng.AEE 562 758→ Eng.ALM 000 707→  LK5006  [3] 85x131x16mm, PTFE (50-319448-00) Eng.AEE 562 758→ Eng.ALM 000 707→	HL5020 [245]  →Eng.AEE 562 757 →Eng.ALM 000 706		



KW/PS



Polo 1.6L						05/97 → 09/01	233	AC5220 (MLS)	CC5221	EC080 [8]
Polo 1.6L 100						12/95 → 09/01		30-029462-00	21-29462-21/0	EC5220 [8]
AEH	1595	4	81.00	Motronic	74/100		APF / AUR	APF / AUR	AEH / AKL	
AFT	1595	4	81.00	SOHC	74/100		AY940 (MLS)	CY941	EC5220 [8]	
AKL	1595	4	81.00		74/100		30-028383-00	21-28383-21/0	EC5220 [8]	
APF	1595	4	81.00	SOHC	74/100		AFT	AFT	APF / AUR	
AUR	1595	4	81.00	Injection, SOHC	74/100		AY980 (MLS)	CY980		
							30-028925-00	21-28925-20/0		
							AEH / AKL	AEH / AKL		
Polo 1.6L 16V						05/06 →	234	AG8850 (MLS)		
BTS	1598	4	76.50	Injection, DOHC	77/105		(30-030218-00)			
Polo 1.6L 16V GTI						10/99 → 09/01	235	AC5280 (MLS)	CC5280 [41]	EB5700 [8]
ARC	1598	4	76.50		92/125		30-029466-00	21-29466-20/0	22-29313-00/0	
AVY	1598	4	76.50	DOHC	92/125					
Polo 1.6L 16V GTI 120						09/98 → 10/99	236	AC5280 (MLS)	CC5280 [41]	EB5700 [8]
AUV	1598	4	76.50	DOHC	88/120		30-029466-00	21-29466-20/0	22-29313-00/0	
Polo 1.6L 75						11/95 → 09/97	237	BM360 (Fibre)	DM368	EG873
1F	1595	4	81.00	Monomotronic, SOHC	53/55/ 72/75		30-026807-30	21-26807-20/0		

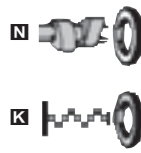
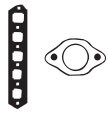

<p>HBS043 [22-39001B] M11x1.50x95mm (x10) AFT</p> <p>HBS246 [22-33024B] M10x1.50x120mm (x10) AEH/AKL/APF/AUR</p>	<p>JD5340 [x4] (50-029939-00) APF / AUR</p> <p>JD607 [50-028924-00] AEH / AKL</p> <p>JD599 [31-027926-00] AFT</p> <p>JD5293 [31-029816-00] APF / AUR</p> <p>JD600 [31-028454-00] AEH / AFT / AKL</p>	<p>JP024 [50-027505-00]</p>	<p>HR397 [57] [34-000410-00] AEH/AKL/APF/AUR</p> <p>JH5117 [50-030046-00] AEH / AKL / APF</p> <p>JJ609 [50-027500-00] (ACM) AFT</p>	<p>HR816 [24-30653-85/0]</p>	<p>NA5001 [32x47x10mm, FPM] (50-303185-50) AFT</p> <p>NA5124 [32x47x10mm, PTFE] (50-319433-00) AEH, AKL, APF, AUR</p> <p>NA5001 [32x47x10mm, FPM] (50-303185-50) AFT</p> <p>NA5106 [35x48x10mm, PTFE] (50-319430-00) AEH, AKL, APF, AUR</p> <p>LK5008 [3] [85x131x15.7mm, PTFE] (50-319472-00) AEH, AKL, APF, AUR</p> <p>NA5133 [85x105x11mm, FPM] (24-30727-87/0) AFT</p>	<p>HL5020 [245] [AFT] HL5034 [245] [AEH, AKL, APF, AUR]</p>
<p>HBS249 [22-33025B] M9x1.25x138mm (x10)</p>	<p>JD5228 [x3] (50-029071-00)</p> <p>JD5814 [31-030234-00]</p>	<p>HR397 [57] [34-000410-00]</p>	<p>HR397 [57] [34-000410-00]</p>	<p>HR791 [24-30614-76/0]</p>	<p>NA5106 [35x48x10mm, PTFE] (50-319430-00)</p>	
<p>HBS316 [22-33036B] M9x1.25x97mm (x10)</p>	<p>JD5373 [31-029966-00]</p> <p>JD5298 [31-029825-00]</p>	<p>HR397 [57] [34-000410-00]</p>	<p>HR397 [57] [34-000410-00]</p>	<p>HR791 [24-30614-76/0]</p>	<p>NA5180 [x2] [27x42x8mm, FPM] (50-319484-00)</p> <p>NA5185 [32x42x6mm, FPM] (50-319489-00)</p> <p>LK5011 [3] [78] [85x131x15.94mm, PTFE]</p>	<p>KA5025 [13] KK5551 [81]</p>
<p>HBS316 [22-33036B] M9x1.25x97mm (x10)</p>	<p>JD5373 [31-029966-00]</p> <p>JD5298 [31-029825-00]</p> <p>JE5076 [31-028373-00]</p>	<p>HR397 [57] [34-000410-00]</p>	<p>HR397 [57] [34-000410-00]</p>	<p>HR791 [24-30614-76/0]</p>	<p>NA5180 [x2] [27x42x8mm, FPM] (50-319484-00)</p> <p>NA5185 [32x42x6mm, FPM] (50-319489-00)</p>	<p>KA5025 [13] KK5551 [81]</p>
<p>HBS043 [22-39001B] M11x1.50x95mm (x10)</p>	<p>JC478 [31-026397-00]</p> <p>PA459 [50-024870-00] (NBR)</p> <p>JC152 [x4] [31-026555-00]</p> <p>JE160 [31-024869-00]</p>	<p>HL457 [79] [24-25753-01/0] (Cork)</p> <p>HM5053 [80] [24-28543-00/0] (ACM)</p>	<p>JJ140 [31-026554-10]</p>	<p>HR569 [24-30667-00/0]</p>	<p>NA5001 [32x47x10mm, FPM] (50-303185-50)</p> <p>NA5001 [32x47x10mm, FPM] (50-303185-50)</p> <p>NA5133 [85x105x11mm, FPM] (24-30727-87/0)</p>	<p>HL5020 [245] [AFT] KA5020 [13]</p>

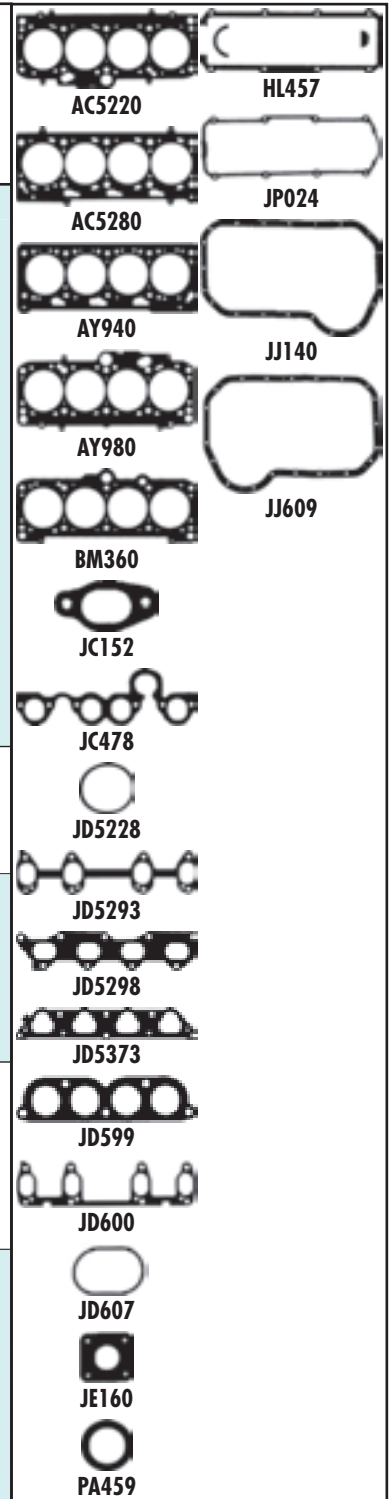









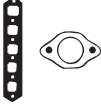

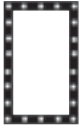

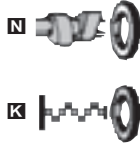





















KW/PS



Polo 1.6L 75				10/94 → 10/99	238	BZ180 (MLS), 0.50mm	DZ180	EB961 [8]
AEA	1598	4	76.50	SOHC	55/75	30-027910-10	21-27910-20/0	22-28897-03/0
AEE	1598	4	76.50	Injection, SOHC	55/75		AEA	AEE / AHS
AHS	1598	4	76.50	OHV	55/75		DZ181	EV460
							21-27910-21/0	22-26516-01/0
							AEE / AHS	AEA
Polo 1.7L SDI Diesel				10/99 → 09/01	239	BX800 (MLS), 1.45mm, 1 Hole	DX801▲	EC030 [8]
						30-028686-00	21-27921-21/0	22-26384-04/0
Polo 1.7L SDI 60 Diesel				08/97 → 10/99				
Polo Van 1.7L SDI Diesel				08/97 → 12/99				
AKU	1716	4	79.50	SOHC	44/60	BX810 (MLS), 1.53mm, 2 Holes 30-028687-00		
						BX820 (MLS), 1.61mm, 3 Holes 30-028688-00		
Polo 1.7L SDI Diesel				04/97 → 10/99	240	BX800 (MLS), 1.45mm, 1 Hole	DX801▲	EC030 [8]
AHG	1716	4	79.50		42/57	30-028686-00	21-27921-21/0	22-26384-04/0
						BX810 (MLS), 1.53mm, 2 Holes 30-028687-00		
						BX820 (MLS), 1.61mm, 3 Holes 30-028688-00		
Polo 1.7L SDI Diesel				08/97 → 09/01	241	BX800 (MLS), 1.45mm, 1 Hole	DX801▲	EC030 [8]
						30-028686-00	21-27921-21/0	22-26384-04/0
Polo 1.7L SDI 57 Diesel				07/97 → 09/01				
AKW	1716	4	79.50	SOHC	42/57	BX810 (MLS), 1.53mm, 2 Holes 30-028687-00		
						BX820 (MLS), 1.61mm, 3 Holes 30-028688-00		
Polo 1.8L 90				01/97 → 09/01	242	BZ910 (MLS)		EB970
ADD	1781	4	81.00		66/89	30-027935-00		22-27500-01/0









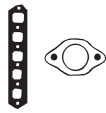

								
HBS075 Ⓞ [22-39011B] M11x1.50x110mm (x10)	JD487 ■ (31-027908-00) AEA JD597 ■ ■ 50-350355-00 AEE / AHS JD488 ■ 31-027909-00 AEA JD601 ■ 31-028644-00 AEE / AHS	JP074 50-027907-00 HM5062 ■ 24-27907-00/0	HR397 [57] 34-000410-00 AHS / AEE JJ183 (31-026516-10) AEA	HR816 ■ 24-30653-85/0	NA5001 32x47x10mm, FPM (50-303185-50) NA5001 ■ 32x47x10mm, FPM (50-303185-50) →Eng.AEE 562 757 →Eng.AHS 050 000 AEA NA5133 ■ 85x105x11mm, FPM (24-30727-87/0) →Eng.AEE 562 757 →Eng.AHS 050 000 AEA NA5185 ■ 32x42x6mm, FPM (50-319489-00) Eng.AEE 562 758 → Eng.AHS 050 001 → LK5006 ■ [3] 85x131x16mm, PTFE (50-319448-00) Eng.AEE 562 758 → Eng.AHS 050 001 →	HL5020 [245] ■ →Eng.AEE 562 757	 BX800, BX810, BX820  BZ180  BZ910  JC152  JD170  JD487  JD488  JD597  JD601  JP003  JP024  JP074  JJ183  JJ609	
HBS018 Ⓞ [22-39024B] M12x1.75x115mm (x10)	JD170 ■ 31-026556-10 JC152 ■ (x4) 31-026555-00	JP003 50-027921-00	JJ609 (50-027500-00) (ACM)	HR816 ■ 24-30653-85/0	NA5001 32x47x10mm, FPM (50-303185-50) NA5001 ■ 32x47x10mm, FPM (50-303185-50) NA5133 ■ 85x105x11mm, FPM (24-30727-87/0) →Eng.AKU 013 000 LK5006 ■ [3] 85x131x16mm, PTFE (50-319448-00) Eng.AKU 013 001 →	HL5020 [245] ■ NA5278 [54]	 JP003  JP024  JP074  JJ183  JJ609	
HBS018 Ⓞ [22-39024B] M12x1.75x115mm (x10)	JD170 ■ 31-026556-10 JC152 ■ (x4) 31-026555-00	JP003 50-027921-00	JJ609 (50-027500-00) (ACM)	HR816 ■ 24-30653-85/0	NA5001 32x47x10mm, FPM (50-303185-50) NA5001 ■ 32x47x10mm, FPM (50-303185-50) NA5133 ■ 85x105x11mm, FPM (24-30727-87/0) →Eng.AHG 010 000 LK5006 ■ [3] 85x131x16mm, PTFE (50-319448-00) Eng.AHG 010 001 →	HL5020 [245] ■ NA5278 [54]	 JP074  JJ183  JJ609	
HBS018 Ⓞ [22-39024B] M12x1.75x115mm (x10)	JD170 ■ 31-026556-10 JC152 ■ (x4) 31-026555-00	JP003 50-027921-00	JJ609 (50-027500-00) (ACM)	HR816 ■ 24-30653-85/0	NA5001 32x47x10mm, FPM (50-303185-50) NA5001 ■ 32x47x10mm, FPM (50-303185-50) LK5006 ■ [3] 85x131x16mm, PTFE (50-319448-00)	HL5020 [245] ■ NA5278 [54]	 JP024  JP074  JJ183  JJ609	
	JC152 ■ (x4) 31-026555-00	JP024 50-027505-00	JJ609 (50-027500-00) (ACM)	HR816 ■ 24-30653-85/0	NA5001 32x47x10mm, FPM (50-303185-50) NA5001 ■ 32x47x10mm, FPM (50-303185-50) NA5133 ■ 85x105x11mm, FPM (24-30727-87/0) LK5006 ■ [3] 85x131x16mm, PTFE (50-319448-00)	HL5020 [245] ■		

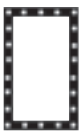

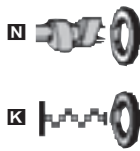
KW/PS



Polo 1.8L GTI				09/05 →	243	AY970 (MLS)	CY971	EY841
BJX	1781	4	81.00	DOHC	110/150	30-028495-00	21-28495-21/0	22-28897-02/0
Polo 1.8L Variant				05/97 →09/01	244	BZ910 (MLS)	DZ910	
ADZ	1781	4	81.00	SOHC	66/89	30-027935-00	21-27935-20/0	
Polo 1.9L D Diesel				10/99 →09/01	245	BV850 (MLS), 1.53mm, 1 Hole	DV850▲	ECO30 [8]
Polo 1.9L D 64 Diesel				10/94 →10/99		30-028545-00	21-26557-20/0	22-26384-04/0
Polo Van 1.9L D Diesel				10/94 →12/99		30-028546-00	→Eng.AEF 007 000	
AEF	1896	4	79.50		47/64	BV860 (MLS), 1.57mm, 2 Holes 30-028546-00	DV851▲ 21-26557-21/0	
Polo 1.9L SDI Diesel				08/99 →09/01 <th>246</th> <th>BZ010 (MLS), 1.45mm, 1 Hole</th> <th>DZ010▲☒</th> <th>ECO60 [8]</th>	246	BZ010 (MLS), 1.45mm, 1 Hole	DZ010▲☒	ECO60 [8]
Polo 1.9L SDI 68 Diesel				08/99 →09/01		30-028910-10	21-26556-20/0	22-28897-00/0
AGP	1896	4	79.50		50/68	→Eng.AGP 028 000	AGP	
AQM	1896	4	79.50	SDi	50/68	BZ020 (MLS), 1.53mm, 2 Holes 30-028911-10 →Eng.AGP 028 000		
						BZ030 (MLS), 1.61mm, 3 Holes 30-028912-10 →Eng.AGP 028 000		
						BZ040 (MLS), 1.47mm, 1 Hole 30-028915-10 Eng.AGP 028 001→ AQM		
						BZ050 (MLS), 1.57mm, 2 Holes 30-028916-10 Eng.AGP 028 001→ AQM		
						BZ060 (MLS), 1.67mm, 3 Holes 30-028917-10 Eng.AGP 028 001→ AQM		
Polo 1.9L SDI Diesel				10/99 →09/01	247	BX800 (MLS), 1.45mm, 1 Hole	DX801▲	ECO30 [8]
Polo 1.9L SDI 64 Diesel				07/96 →10/99		30-028686-00	21-27921-21/0	22-26384-04/0
Polo Van 1.9L SDI Diesel				07/96 →12/99		BX810 (MLS), 1.53mm, 2 Holes 30-028687-00		
AGD/ASX	1896	4	79.50		47/64	BX820 (MLS), 1.61mm, 3 Holes 30-028688-00		

								 AY970	 JJ609
HBS268 ® (22-33031B) M10x1.50x120mm (x10)	JD604 ■ (31-028824-00) JD605 ■ 31-028826-00	HL732 ■ 24-28815-00/0	HR397 [57] 34-000410-00	HR822 ■	NA5124 (x2) 32x47x10mm, PTFE (50-319433-00) NA5106 ■ 35x48x10mm, PTFE (50-319430-00) LK5003 ■ [3] 85x131x15.7mm, PTFE (50-319434-00)	HL5040 [245]■		BV850, BV860, BV870	
	JD5235 ■ (31-028554-00) JC152 ■ (x4) 31-026555-00	JP024 50-027505-00	JJ609 (50-027500-00) (ACM)	HR816 ■ 24-30653-85/0	NA5001 32x47x10mm, FPM (50-303185-50) NA5001 ■ 32x47x10mm, FPM (50-303185-50) NA5133 ■ 85x105x11mm, FPM (24-30727-87/0)	HL5020 [245]■		BX800, BX810, BX820	
HBS018 ® (22-39024B) M12x1.75x115mm (x10)	JD170 ■ 31-026556-10 JC152 ■ (x4) 31-026555-00  JE5076 (31-028373-00)	JN914 50-026557-10 HM5058 ■ 24-26557-00/0	JH5023 (31-029043-00)	HR569 ■ 24-30667-00/0 →Eng.AEF 007 000 HR816 ■ 24-30653-85/0 Eng.AEF 007 001→	NA5001 32x47x10mm, FPM (50-303185-50) NA5001 ■ 32x47x10mm, FPM (50-303185-50) NA5133 ■ 85x105x11mm, FPM (24-30727-87/0) →Eng.AEF 265 000 LK5006 ■ [3] 85x131x16mm, PTFE (50-319448-00) Eng.AEF 265 001→	HL5020 [245]■		BZ010, BZ020, BZ030	
HBS018 ® (22-39024B) M12x1.75x115mm (x10)	JD170 ■ 31-026556-10 JC152 ■ (x4) 31-026555-00 AGP JD600 ■ 31-028454-00 AQM  JE5076 (31-028373-00)		HR397 [57] 34-000410-00	HR816 ■ 24-30653-85/0	NA5001 32x47x10mm, FPM (50-303185-50) NA5106 ■ 35x48x10mm, PTFE (50-319430-00) LK5003 ■ [3] 85x131x15.7mm, PTFE (50-319434-00)	NA5278 [54]		BZ040, BZ050, BZ060	
HBS018 ® (22-39024B) M12x1.75x115mm (x10)	JD170 ■ 31-026556-10 JC152 ■ (x4) 31-026555-00	JP003 50-027921-00	JJ609 (50-027500-00) (ACM)	HR816 ■ 24-30653-85/0	NA5001 32x47x10mm, FPM (50-303185-50) NA5001 ■ 32x47x10mm, FPM (50-303185-50) NA5133 ■ 85x105x11mm, FPM (24-30727-87/0) →Eng.AGD 015 000 LK5006 ■ [3] 85x131x16mm, PTFE (50-319448-00) Eng.AGD 015 001→ ASX	HL5020 [245]■ NA5278 [54]		BZ910	
								JC152	
								JD170	
								JD5235	
								JD600	
								JD604	
								JD605	
								JN914	
								JP003	
								JP024	
								JH5023	











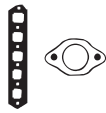

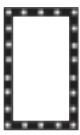

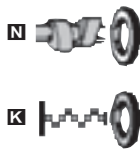

VW



KW/PS



Polo 1.9L SDI Diesel		10/01 →		248		BZ040 (MLS), 1.47mm, 1 Hole 30-028915-10 BZ050 (MLS), 1.57mm, 2 Holes 30-028916-10 BZ060 (MLS), 1.67mm, 3 Holes 30-028917-10		CC5231▲ 21-29463-20/0		EB5370 [8] 22-29314-00/0	
ASY	1896	4	79.50	Direct Injection, SOHC	47/64						
Polo 1.9L SDI Diesel		06/97 → 09/01		249		BX800 (MLS), 1.45mm, 1 Hole 30-028686-00 BX810 (MLS), 1.53mm, 2 Holes 30-028687-00 BX820 (MLS), 1.61mm, 3 Holes 30-028688-00		DX801▲ 21-27921-21/0		ECO30 [8] 22-26384-04/0	
AEY	1896	4	79.50	SDi	47/64						
Polo 1.9L SDI 64 Diesel		12/95 → 08/99		250		BX800 (MLS), 1.45mm, 1 Hole 30-028686-00 AEY BV850 (MLS), 1.53mm, 1 Hole 30-028545-00 1Y BX810 (MLS), 1.53mm, 2 Holes 30-028687-00 AEY BV860 (MLS), 1.57mm, 2 Holes 30-028546-00 1Y BX820 (MLS), 1.61mm, 3 Holes 30-028688-00 AEY BV870 (MLS), 1.61mm, 3 Holes 30-028547-00 1Y		DV850▲ 21-26557-20/0 → Eng. 1Y 580 000 DX801▲ 21-27921-21/0 AEY DV851▲ 21-26557-21/0 Eng. 1Y 580 001 →		ECO30 [8] 22-26384-04/0	
AEY	1896	4	79.50	SDi	47/64						
1Y	1896	4	79.50		47/50/ 64/68						
Polo 1.9L TDI Diesel		06/98 → 09/01		251		BX800 (MLS), 1.45mm, 1 Hole 30-028686-00 AFN BZ040 (MLS), 1.47mm, 1 Hole 30-028915-10 ASV BX810 (MLS), 1.53mm, 2 Holes 30-028687-00 AFN BZ050 (MLS), 1.57mm, 2 Holes 30-028916-10 ASV BX820 (MLS), 1.61mm, 3 Holes 30-028688-00 AFN BZ060 (MLS), 1.67mm, 3 Holes 30-028917-10 ASV		DX800▲ 21-27921-20/0 → Eng. AFN 002 000 DZ010▲☒ 21-26556-20/0 ASV DX801▲ 21-27921-21/0 Eng. AFN 002 001 →		ECO30 [8] 22-26384-04/0 AFN ECO60 [8] 22-28897-00/0 ASV	
AFN/ASV	1896	4	79.50	SOHC	81/110						
Polo 1.9L TDI Diesel		10/01 →		252		AF5381 (MLS), 1.49mm, 1 Hole 30-030098-10 AF5391 (MLS), 1.57mm, 2 Holes 30-030099-10 AF5401 (MLS), 1.65mm, 3 Holes 30-030100-10		CC5230▲ 21-29463-21/0 BLT CC5231▲ 21-29463-20/0 ASZ, ATD, AXR, BMT		EB5370 [8] 22-29314-00/0	
ATD	1896	4	79.50		74/100						
AXR	1896	4	79.50	PDi, SOHC	74/100						
BMT	1896	4	79.50	SOHC	74/101						
ASZ	1896	4	79.50	PDi, SOHC	96/131						
BLT	1896	4	79.50	Direct Injection, SOHC	96/131						

								 BV850, BV860, BV870
HBS018 Ⓞ (22-39024B) M12x1.75x115mm (x10)	JD170 ■ 31-026556-10 JC152 ■ (x4) 31-026555-00	JM5203 50-029934-00	HR397 [57] 34-000410-00	HR816 ■ 24-30653-85/0	NA5124 32x47x10mm, PTFE (50-319433-00) NA5106 ■ 35x48x10mm, PTFE (50-319430-00) LK5003 ■ [3] 85x131x15.7mm, PTFE (50-319434-00)	HL5034 [245]■ NA5278 [54]		 BX800, BX810, BX820
HBS018 Ⓞ (22-39024B) M12x1.75x115mm (x10)	JD170 ■ 31-026556-10 JC152 ■ (x4) 31-026555-00 JE5076 (31-028373-00)	JP003 50-027921-00	JJ609 (50-027500-00) (ACM)	HR816 ■ 24-30653-85/0	NA5001 32x47x10mm, FPM (50-303185-50) NA5001 ■ 32x47x10mm, FPM (50-303185-50) NA5133 ■ 85x105x11mm, FPM (24-30727-87/0) →Eng.AEY 050 000 LK5006 ■ [3] 85x131x16mm, PTFE (50-319448-00) Eng.AEY 050 001→	HL5020 [245]■		 BZ040, BZ050, BZ060  JC152  JD170  JD600
HBS018 Ⓞ (22-39024B) M12x1.75x115mm (x10)	JD170 ■ 31-026556-10 JC152 ■ (x4) 31-026555-00 JE5076 (31-028373-00)	JN914 50-026557-10 1Y JP003 50-027921-00 AEY HM5058 ■ 24-26557-00/0 1Y	JH5023 (31-029043-00) 1Y JJ609 (50-027500-00) (ACM) AEY	HR569 ■ 24-30667-00/0 →Eng.1Y 580 000 HR816 ■ 24-30653-85/0 Eng.1Y 580 001→ AEY	NA5001 32x47x10mm, FPM (50-303185-50) NA5001 ■ 32x47x10mm, FPM (50-303185-50) NA5133 ■ 85x105x11mm, FPM (24-30727-87/0) →Eng.AEY 050 000 1Y LK5006 ■ [3] 85x131x16mm, PTFE (50-319448-00) Eng.AEY 050 001→	HL5020 [245]■ NA5278 [54]		 JN914  JP003  JH5023  JJ609
HBS018 Ⓞ (22-39024B) M12x1.75x115mm (x10)	JD170 ■ 31-026556-10 JC152 ■ (x4) 31-026555-00	JP003 50-027921-00 AFN	JJ609 (50-027500-00) (ACM) →Eng.AFN 866 421 HR397 [57] 34-000410-00 Eng.AFN 866 422→ ASV	HR569 ■ 24-30667-00/0 →Eng.AFN 002 000 HR816 ■ 24-30653-85/0 Eng.AFN 002 001→ ASV	NA5001 32x47x10mm, FPM (50-303185-50) NA5106 ■ 35x48x10mm, PTFE (50-319430-00) NA5001 ■ 32x47x10mm, FPM (50-303185-50) AFN LK5003 ■ [3] 85x131x15.7mm, PTFE (50-319434-00) ASV NA5133 ■ 85x105x11mm, FPM (24-30727-87/0) →Eng.AFN 576 000 LK5006 ■ [3] 85x131x16mm, PTFE (50-319448-00) Eng.AFN 576 001→	HL5020 [245]■		
HBS300 Ⓞ (22-33034B) M12x1.75x166mm (x10)	JD170 ■ 31-026556-10 JC152 ■ (x4) 31-026555-00 ASZ, ATD, AXR, BMT JD600 ■ 31-028454-00 BLT	JM5203 50-029934-00	HR397 [57] 34-000410-00	HR816 ■ 24-30653-85/0	NA5124 32x47x10mm, PTFE (50-319433-00) NA5106 ■ 35x48x10mm, PTFE (50-319430-00) LK5003 ■ [3] 85x131x15.7mm, PTFE (50-319434-00)	HL5034 [245]■		



KW/PS



Polo 1.9L TDI Diesel				05/97 → 09/01	253	BX800 (MLS), 1.45mm, 1 Hole		DX800▲	EC030 [8]
Polo 1.9L TDI 90 Diesel				09/96 → 09/01		30-028686-00		21-27921-20/0	22-26384-04/0
AGR	1896	4	79.50	SOHC	66/89	AHU / ALE		AHU	AHU / ALE
AHU/ALE/ALH	1896	4	79.50		66/89	BX810 (MLS), 1.53mm, 2 Holes 30-028687-00 AHU / ALE BX820 (MLS), 1.61mm, 3 Holes 30-028688-00 AHU / ALE BZ010 (MLS), 1.45mm, 1 Hole 30-028910-10 →Eng.AGR 151 000 →Eng.ALH 085 000 BZ020 (MLS), 1.53mm, 2 Holes 30-028911-10 →Eng.AGR 151 000 →Eng.ALH 085 000 BZ030 (MLS), 1.61mm, 3 Holes 30-028912-10 →Eng.AGR 151 000 →Eng.ALH 085 000 BZ040 (MLS), 1.47mm, 1 Hole 30-028915-10 Eng.AGR 151 001 → Eng.ALH 085 001 → BZ050 (MLS), 1.57mm, 2 Holes 30-028916-10 Eng.AGR 151 001 → Eng.ALH 085 001 → BZ060 (MLS), 1.67mm, 3 Holes 30-028917-10 Eng.AGR 085 001 → Eng.ALH 085 001 →		DZ010▲ ☒ 21-26556-20/0 AGR / ALH	EC060 [8] 22-28897-00/0 AGR / ALH
Santana 1.8L				08/84 → 07/94	254	BM360 (Fibre)			EG873
DS	1781	4	81.00		66/89	30-026807-30			
Santana 1.9L				08/81 → 07/83	255	BD620 (Fibre)		DD621	EX995
WN	1921	5	79.50		85/115	30-024697-10		(21-24697-25/0)	(22-23856-06/0)
Scirocco Coupe 1.6L				01/83 → 07/90	256	BM360 (Fibre)		DM368	EG873
EWA	1595	4	81.00		51-55/ 70-75	30-026807-30		21-26807-20/0	
RE	1595	4	81.00		53/72				
EW	1595	4	81.00		55/75				

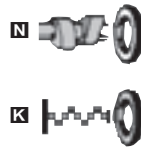
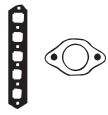

BD620



BM360



BX800, BX810,
BX820



BZ010, BZ020,
BZ030



BZ040, BZ050,
BZ060



JC152



JC261



JC478



JD170



JE160



JE689



PA459



HL457



HL460



JP003



JJ140



JJ184



JJ609

HBS018Ⓞ
(22-39024B)
M12x1.75x115mm (x10)

JD170■
31-026556-10
JC152■ (x4)
31-026555-00

JP003
50-027921-00
AHU / ALE

HR397 [57]
34-000410-00
AGR / ALH
JJ609
(50-027500-00)
(ACM)
AHU / ALE

HR569■
24-30667-00/0
AHU
HR816■
24-30653-85/0
AGR / ALH /
ALE

■ **NA5001** 32x47x10mm, FPM
(50-303185-50)
■ **NA5001**■ 32x47x10mm, FPM
(50-303185-50)
AHU / ALE
■ **NB716**■ 35x48x10mm, FPM
(50-306067-50)
AGR / ALH
■ **NA5133**■ 85x105x11mm, FPM
(24-30727-87/0)
→Eng.AHU 390 000
→Eng.ALE 576 000
■ **LK5003**■ [3] 85x131x15.7mm, PTFE
(50-319434-00)
AGR / ALH
■ **LK5006**■ [3] 85x131x16mm, PTFE
(50-319448-00)
Eng.AHU 390 001→
Eng.ALE 576 001→

HL5020 [245]■
NA5278 [54]

HBS043Ⓞ
(22-39001B)
M11x1.50x95mm (x10)

JC478■
31-026397-00
PA459■
50-024870-00
(NBR)
JC152■ (x4)
31-026555-00
Ⓞ **JE689**
(31-024039-00)

HL457■ [79]
24-25753-01/0
(Cork)
HM5053■ [80]
24-28543-00/0
(ACM)

JJ140
(31-026554-10)

HR569■
24-30667-00/0

■ **NA5001** 32x47x10mm, FPM
(50-303185-50)
■ **NA5001**■ 32x47x10mm, FPM
(50-303185-50)
■ **NA5133**■ 85x105x11mm, FPM
(24-30727-87/0)

HL5020 [245]■
KA5020 [13]

HBS024Ⓞ
(22-39002B)
M11x1.50x95mm (x12)

JC261■
(31-026898-00)
JC152■ (x5)
31-026555-00
Ⓞ **JE689**
(31-024039-00)

JN438
(50-026864-00)
(Rubber)
HL460■
(Cork)
HM5277■
24-26864-00/0
(Rubber)

JJ184
(31-023856-10)

HR615■
24-30667-05/0

■ **NA5001** 32x47x10mm, FPM
(50-303185-50)
■ **NB716**■ 35x48x10mm, FPM
(50-306067-50)
■ **NA5133**■ 85x105x11mm, FPM
(24-30727-87/0)

HBS043Ⓞ
(22-39001B)
M11x1.50x95mm (x10)

JC478■
31-026397-00
PA459■
50-024870-00
(NBR)
JC152■ (x4)
31-026555-00
Ⓞ **JE160**
(31-024869-00)

HL457■ [79]
24-25753-01/0
(Cork)
HM5053■ [80]
24-28543-00/0
(ACM)

JJ140
(31-026554-10)

HR569■
24-30667-00/0

■ **NA5001** 32x47x10mm, FPM
(50-303185-50)
■ **NA5001**■ 32x47x10mm, FPM
(50-303185-50)
■ **NA5133**■ 85x105x11mm, FPM
(24-30727-87/0)

HL5020 [245]■
KA5020 [13]











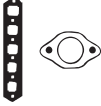

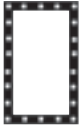

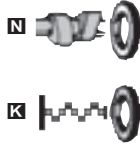





VW



KWPS

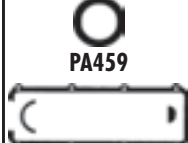

Scirocco Coupe 1.8L				08/83 → 07/92	257	BM360 (Fibre)	DM368	EG873	
EX	1781	4	81.00	K-Jetronic	66/89	30-026807-30	21-26807-20/0		
JH	1781	4	81.00		70/95				
Scirocco Coupe 1.8L				08/82 → 12/89	258	BM360 (Fibre)	DM368	EG873	
DX	1781	4	81.00	K-Jetronic	82/111	30-026807-30	21-26807-20/0	EG873	
EV	1781	4	81.00		82/111				
JJ	1781	4	81.00	SOHC	82/111	30-026807-30	21-26807-20/0	EG873	
PB	1781	4	81.00		82/111				
				Digifant			08/83 →		
Scirocco Coupe 1.8L 16V				10/85 → 07/92	259	BM360 (Fibre)	DM365	ET811	
PL	1781	4	81.00	K-Jetronic	95/129	30-026807-30	21-26807-21/0	ET811 (22-26554-40/0)	
KR	1781	4	81.00		98/133				
Sharan 1.8L T 20V				09/97 →	260	AY970 (MLS)	CY971	EY841	
AJH	1781	4	81.00	DOHC	110/150	30-028495-00	21-28495-21/0	22-28897-02/0	
AWC	1781	4	81.00		110/150				
Sharan 1.9L TDI Diesel				04/00 →	261	AF5381 (MLS), 1,49mm, 1 Hole	CC5231▲	EB5370 [8]	
Sharan 1.9L TDI 4motion Diesel				04/00 →		30-030098-10	21-29463-20/0	22-29314-00/0	
BVK	1896	4	79.50	Direct Injection, SOHC	85/115	AF5391 (MLS), 1,57mm, 2 Holes	30-030099-10	AF5401 (MLS), 1,65mm, 3 Holes	
AUY	1896	4	79.50		85/116				
ASZ	1896	4	79.50		96/131				
				PDi, SOHC		30-030100-10			
Sharan 1.9L TDI Diesel				06/05 →	262	AF5381 (MLS), 1,49mm, 1 Hole	CC5230▲	EB5370 [8]	
BTB	1896	4	79.50	Direct Injection, SOHC	110/150	AF5391 (MLS), 1,57mm, 2 Holes	30-030099-10	AF5401 (MLS), 1,65mm, 3 Holes	

								
HBS043 Ⓢ (22-39001B) M11x1.50x95mm (x10)	JC478 ■ 31-026397-00 PA459 ■ 50-024870-00 (NBR) JC152 ■ (x4) 31-026555-00 Ⓢ JE160 (31-024869-00)	HL457 ■ [79] 24-25753-01/0 (Cork) HM5053 ■ [80] 24-28543-00/0 (ACM)	JJ140 (31-026554-10)	HR569 ■ 24-30667-00/0	NA5001 32x47x10mm, FPM (50-303185-50) NA5001 ■ 32x47x10mm, FPM (50-303185-50) NA5133 ■ 85x105x11mm, FPM (24-30727-87/0)	HL5020 [245]■ KA5020 [13]		 AY970  BM360  JC152  JC478  JD170  JD281  JD282  JD600  JD604  JD605  JE117  JE160  PA459  HL457  JJ140
HBS043 Ⓢ (22-39001B) M11x1.50x95mm (x10)	JC478 ■ 31-026397-00 PA459 ■ 50-024870-00 (NBR) JC152 ■ (x4) 31-026555-00 Ⓢ JE117 (31-023565-10) →07/83 Ⓢ JE160 (31-024869-00) 08/83→	HL457 ■ [79] 24-25753-01/0 (Cork) HM5053 ■ [80] 24-28543-00/0 (ACM)	JJ140 (31-026554-10)	HR569 ■ 24-30667-00/0	NA5001 32x47x10mm, FPM (50-303185-50) NA5001 ■ 32x47x10mm, FPM (50-303185-50) NA5133 ■ 85x105x11mm, FPM (24-30727-87/0)	HL5020 [245]■ KA5020 [13]		
HBS028 Ⓢ (22-39004B) M11x1.50x147mm (x10)	JD281 ■ (31-027904-00) JD282 ■ (x4) (31-026880-00) Ⓢ JF205 (31-025070-00)	HL606 ■ 24-26237-01/0	JJ140 (31-026554-10)	HR816 ■ (x2) 24-30653-85/0	NA5001 32x47x10mm, FPM (50-303185-50) NA5001 ■ 32x47x10mm, FPM (50-303185-50) NA5133 ■ 85x105x11mm, FPM (24-30727-87/0)	HL5020 [245]■		
HBS268 Ⓢ (22-33031B) M10x1.50x120mm (x10)	JD604 ■ (31-028824-00) JD605 ■ 31-028826-00	HL732 ■ 24-28815-00/0	HR397 [57] 34-000410-00 JH5117 (50-030046-00)	HR822 ■	NA5124 (x2) 32x47x10mm, PTFE (50-319433-00) NA5106 ■ 35x48x10mm, PTFE (50-319430-00) LK5003 ■ [3] 85x131x15.7mm, PTFE (50-319434-00)	HL5040 [245]■		
HBS300 Ⓢ (22-33034B) M12x1.75x166mm (x10)	JD170 ■ 31-026556-10 JC152 ■ (x4) 31-026555-00	JM5203 50-029934-00	HR397 [57] 34-000410-00	HR816 ■ 24-30653-85/0	NA5124 32x47x10mm, PTFE (50-319433-00) NA5106 ■ 35x48x10mm, PTFE (50-319430-00) LK5003 ■ [3] 85x131x15.7mm, PTFE (50-319434-00)	HL5034 [245]■		
HBS300 Ⓢ (22-33034B) M12x1.75x166mm (x10)	JD170 ■ 31-026556-10 JD600 ■ 31-028454-00	JM5203 50-029934-00	HR397 [57] 34-000410-00	HR816 ■ 24-30653-85/0	NA5124 32x47x10mm, PTFE (50-319433-00) NA5106 ■ 35x48x10mm, PTFE (50-319430-00) LK5003 ■ [3] 85x131x15.7mm, PTFE (50-319434-00)	HL5034 [245]■		



KW/PS



Sharan 1.9L TDI Diesel					09/95 →	263			CC5230▲	EB5370 [8]
IZ	1896	4	79.50	SOHC	66/89	BX800 (MLS), 1.45mm, 1 Hole 30-028686-00		21-29463-21/0	22-29314-00/0	
AHU	1896	4	79.50		66/89	AHU, IZ		ANU	ANU	
ANU	1896	4	79.50	SOHC	66/89	BX810 (MLS), 1.53mm, 2 Holes 30-028687-00		DX800▲	ECO30 [8]	
						AHU, IZ		21-27921-20/0	22-26384-04/0	
						BX820 (MLS), 1.61mm, 3 Holes 30-028688-00		→Eng.IZ-720 000	IZ	
						AHU, IZ		AHU		
						AF5381 (MLS), 1.49mm, 1 Hole 30-030098-10		DX801▲		
						ANU		21-27921-21/0		
						AF5391 (MLS), 1.57mm, 2 Holes 30-030099-10		Eng.IZ-720 001 →		
						ANU				
						AF5401 (MLS), 1.65mm, 3 Holes 30-030100-10				
						ANU				
Sharan 1.9L TDI Diesel					09/96 →04/00	264			DX800▲	ECO30 [8]
AFN	1896	4	79.50	SOHC	81/110	BX800 (MLS), 1.45mm, 1 Hole 30-028686-00		21-27921-20/0	22-26384-04/0	
AVG	1896	4	79.50		81/110	BX810 (MLS), 1.53mm, 2 Holes 30-028687-00		→Eng.AFN 002 000		
						BX820 (MLS), 1.61mm, 3 Holes 30-028688-00		DX801▲		
								21-27921-21/0		
								Eng.AFN 002 001 →		
								AVG		
Sharan 2.0L					09/95 →	265			DY753	EB5370 [8]
ADY	1984	4	82.50	OHV	85/116	AB5370 (MLS) 30-029314-00		21-27930-23/0	22-29314-00/0	
ATM	1984	4	82.50	SOHC	85/116	ATM		ADY	ATM	
						BY750 (MLS) 30-027930-00			EB970	
						ADY			22-27500-01/0	
									ADY	
Sharan 2.0L TDI Diesel					11/05 →	266				EF5380
BRT	1968	4	81.00	Direct Injection, DOHC	103/140	AG9630 (MLS), 1.45mm, 1 Hole 30-030349-00			22-30369-00/0	
						AG9640 (MLS), 1.53mm, 2 Holes				
						AG9650 (MLS), 1.61mm, 3 Holes				

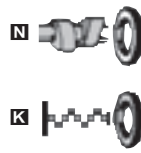
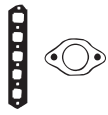

HBS018Ⓞ
(22-39024B)
M12x1.75x115mm (x10)
AHU, 1Z
HBS300Ⓞ
(22-33034B)
M12x1.75x166mm (x10)
ANU

JD170■
31-026556-10
AHU, ANU, 1Z
JC152■ (x4)
31-026555-00
AHU, 1Z
JD600■
31-028454-00
ANU

JM5203
50-029934-00
ANU
JP003
50-027921-00
AHU, 1Z

HR397 [57]
34-000410-00
ANU
JJ609
(50-027500-00)
(ACM)
AHU, 1Z

HR569■
24-30667-00/0
→Eng.1Z-720
000
AHU
HR816■
24-30653-85/0
Eng.1Z-720
001→
ANU

■ **NA5001** 32x47x10mm, FPM
(50-303185-50)
AHU, 1Z
■ **NA5124** 32x47x10mm, PTFE
(50-319433-00)
ANU
■ **NA5001**■ 32x47x10mm, FPM
(50-303185-50)
AHU, 1Z
■ **NA5106**■ 35x48x10mm, PTFE
(50-319430-00)
ANU
■ **LK5003**■ [3] 85x131x15.7mm, PTFE
(50-319434-00)
ANU
■ **NA5133**■ 85x105x11mm, FPM
(24-30727-87/0)
→Eng.AHU 390 000
1Z
■ **LK5006**■ [3] 85x131x16mm, PTFE
(50-319448-00)
Eng.AHU 390 001→

HL5020 [245]■
AHU, 1Z
HL5034 [245]■
ANU
NA5278 [54]

HBS018Ⓞ
(22-39024B)
M12x1.75x115mm (x10)

JD170■
31-026556-10
JC152■ (x4)
31-026555-00

JP003
50-027921-00

JJ609
(50-027500-00)
(ACM)

HR569■
24-30667-00/0
→Eng.AFN 002
000
HR816■
24-30653-85/0
Eng.AFN 002
001→
AVG

■ **NA5001** 32x47x10mm, FPM
(50-303185-50)
■ **NA5001**■ 32x47x10mm, FPM
(50-303185-50)
■ **NA5133**■ 85x105x11mm, FPM
(24-30727-87/0)
→Eng.AFN 576 000
■ **LK5006**■ [3] 85x131x16mm, PTFE
(50-319448-00)
Eng.AFN 576 000→
AVG

HL5020 [245]■
NA5278 [54]

HBS043Ⓞ
(22-39001B)
M11x1.50x95mm (x10)
ADY
HBS246Ⓞ
(22-33024B)
M10x1.50x120mm (x10)
ATM

JD483■
(31-027352-00)
ADY
JD5292■ ■
(31-029815-00)
ATM
JC152■ (x4)
31-026555-00
ADY
JD5293■
(31-029816-00)
ATM
Ⓞ **JF205**
(31-025070-00)

JM5103
(50-029547-00)
ATM
JP024
50-027505-00
ADY

HR397 [57]
34-000410-00
ATM
JJ609
(50-027500-00)
(ACM)
ADY

HR816■
24-30653-85/0

■ **NA5001** 32x47x10mm, FPM
(50-303185-50)
ADY
■ **NA5124** 32x47x10mm, PTFE
(50-319433-00)
ATM
■ **NA5001**■ 32x47x10mm, FPM
(50-303185-50)
ADY
■ **NA5106**■ 35x48x10mm, PTFE
(50-319430-00)
ATM
■ **NA5133**■ 85x105x11mm, FPM
(24-30727-87/0)
ADY
■ **LK5006**■ [3] 85x131x16mm, PTFE
(50-319448-00)
ADY
■ **LK5003**■ [3] 85x131x15.7mm, PTFE
(50-319434-00)
ATM

HL5020 [245]■
ADY
HL5034 [245]■
ATM

HBS300Ⓞ
(22-33034B)
M12x1.75x166mm (x10)

JD170■
31-026556-10
JD600■
31-028454-00

HR397 [57]
34-000410-00

HR816■
24-30653-85/0

■ **NA5124** 32x47x10mm, PTFE
(50-319433-00)
■ **NA5106**■ 35x48x10mm, PTFE
(50-319430-00)
■ **LK5012**■ [3] [85] 85x132x15.7mm, ACM
(50-319535-00)

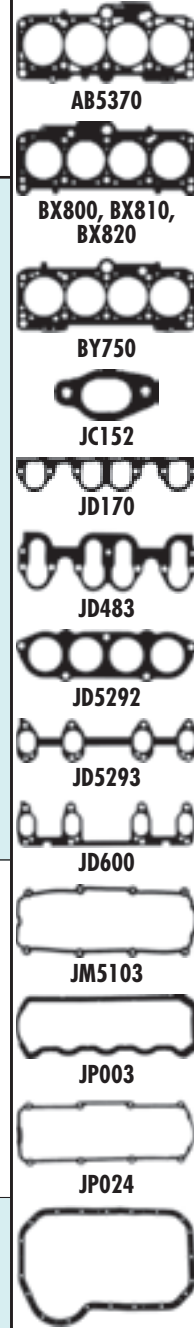

VW



KW/PS



Sharan 2.8L V6 24V					04/00 →	267	AG5000 (MLS)	CG5030	EG5010
AYL	2792	6	81.00	DOHC, V6		150/204	(30-030123-00)	21-30123-30/0	
Sharan 2.8L VR6					09/95 → 04/00	268	AA5430 (Fibre)	CA5430	EC340
Sharan 2.8L VR6 Syncro					11/96 → 04/00		30-027920-00	21-27920-20/0	(22-28817-00/0)
AAA	2792	6	81.00	Injection, DOHC, V6		128/174	AAA	→ Eng.AAA 146 000	Eng.AAA 146 001 →
AMY	2792	6	81.00	DOHC, V6		128/174			
Taro 2.4L i 4x4					06/89 → 03/97	269	BM880 (Graphite)	DM881	GM881
22R	2366	4	92.00	SOHC		84/114	(30-028081-00)	(21-28081-21/0)	
Touareg 3.0L V6 TDI Diesel					11/04 →	270	AG8880 (MLS), 1.1mm, 1 Hole [87]		
BKS	2967	6	83.00	Direct Injection, DOHC, V6		165/224	30-030240-00 AG8900 (MLS), 1.1mm, 1 Hole [88] 30-030242-00 AG8860 (MLS), 1.15mm, 2 Holes [87] 30-030219-00 AG8870 (MLS), 1.15mm, 2 Holes [88] 30-030220-00 AG8890 (MLS), 1.2mm, 3 Holes [87] 30-030241-00 AG8910 (MLS), 1.2mm, 3 Holes [88] 30-030243-00		
Touareg 3.2L V6					10/02 → 11/06	271	AG9610 (MLS)	CG9610	
AZZ	3189	6	84.00	DOHC, V6		162/220	30-030350-00	21-30350-00/0	
BAA	3189	6	84.00	Injection, DOHC, V6		162/220			
BKJ	3189	6	84.00	DOHC, V6		162/220			
BMX	3189	6	84.00	Injection, DOHC, V6		177/241			
Touran 1.6L					07/03 →	272	AC5220 (MLS)	CC5222	
BGU/BSE/BSF	1595	4	81.00	SOHC		75/102	30-029462-00	21-29462-22/0	
Touran 1.6L FSI					02/03 →	273	AG8850 (MLS)	CG8850	
BAG/BLF/BLP	1598	4	76.50	Injection, DOHC		85/115	(30-030218-00)	21-30218-00/0	
Touran 1.9L TDI Diesel					02/03 →	274	AF5381 (MLS), 1,49mm, 1 Hole	CC5230	EF5380
BRU	1896	4	79.50	Direct Injection		66/89	30-030098-10	21-29463-21/0	22-30369-00/0
BXJ	1896	4	79.50	Direct Injection, SOHC		66/90	AF5391 (MLS), 1,57mm, 2 Holes		
AVQ	1896	4	79.50	DOHC		74/100	30-030099-10		
BKC	1896	4	79.50			77/105	AF5401 (MLS), 1,65mm, 3 Holes		
BXE	1896	4	79.50	Direct Injection, SOHC		77/105	30-030100-10		
Touran 2.0L FSI					10/03 →	275	AG9600 (MLS)	CG9600	EG9600
AXW	1984	4	82.50	Injection		110/150	30-030352-00	21-30352-00/0	22-30370-00/0
BLR	1984	4	82.50	Injection, DOHC		110/150		AXW	
BLX	1984	4	82.50			110/150			
BLY	1984	4	82.50	Injection, DOHC		110/150			

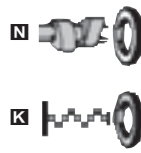
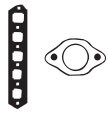

AA5430



AC5220



AG5000



BM880



JA5068

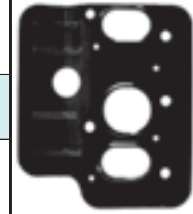

JA5069



JD170



JD5109



JD5232

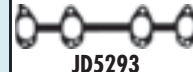

JD5293



JD600

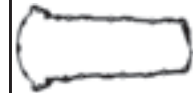

JM5030



JM5099



JH5013



JH5059

	JD5857 ■ 50-030160-00 (Rubber)	JM7045 50-030133-00 (Rubber)	HR397 [57] 34-000410-00	HR5062 ■ 24-30614-73/0	NA5106 ■ 35x48x10mm, PTFE (50-319430-00)		
HBS077 ⊕ (22-39012B) M11x1.50x85mm (x7) M11x1.50x144mm (x3) M11x1.50x119mm (x10) AAA	JD5232 ■ ■ (31-027918-00) JA5068 ■ ■ (31-027917-00) JA5069 ■ [28] (31-027913-00) JD5109 ■ [29] (31-027914-00)	JM5030 50-027915-00 →Eng.AAA 146 000 JM5099 50-029103-00 Eng.AAA 146 001→ AMY	HR397 [57] 34-000410-00 AMY JH5013 (31-027911-00) →Eng.AAA 146 000 JH5059 (50-028817-00) Eng.AAA 146 001→	HR602 ■ 24-30670-61/0	NB716 ■ 35x48x10mm, FPM (50-306067-50) NA5133 ■ 85x105x11mm, FPM (24-30727-87/0)		
HBS386 (22-71022B)					NK214 ■ 35x63x16.5mm		
HBS361 ⊕ (22-33037B) M12x1.50x159mm (x16)	JD5872 ■ (x2) 50-030355-00 (ACM)	JM7046 [87] 50-030356-00 (ACM) JM7047 [88] 50-030357-00 (ACM)	HR397 [57] 34-000410-00	HR5062 ■ 24-30614-73/0	NA5001 (x2) 32x47x10mm, FPM (50-303185-50)		
HBS466 (22-33039B)	JD5874 ■ 50-030351-00 (FPM)	JM7045 50-030133-00 (Rubber)	HR397 [57] 34-000410-00	HR5062 ■ 24-30614-73/0	NA5106 ■ 35x48x10mm, PTFE (50-319430-00)		
HBS246 ⊕ (22-33024B) M10x1.50x120mm (x10)	JD5340 ■ (x4) (50-029939-00) JD5293 ■ (31-029816-00)	JM5205 50-029938-00 (Rubber)	HR397 [57] 34-000410-00	HR817 ■ 24-30614-78/0	NA5124 32x47x10mm, PTFE (50-319433-00) NA5106 ■ 35x48x10mm, PTFE (50-319430-00)	HL5034 [245] ■	
HBS249 ⊕ (22-33025B) M9x1.25x138mm (x10)	JD5809 ■ 31-030229-00 JD5814 ■ 31-030234-00	HR397 [57] 34-000410-00	HR397 [57] 34-000410-00	HR791 ■ 24-30614-76/0	NA5106 ■ 35x48x10mm, PTFE (50-319430-00) LK5011 ■ [3] [78] 85x131x15.94mm, PTFE →07/05 LK5013 ■ [3] [118] 85x111x15.5mm 08/05→		
HBS300 ⊕ (22-33034B) M12x1.75x166mm (x10)	JD170 ■ 31-026556-10 JD600 ■ 31-028454-00	JM5203 50-029934-00	HR397 [57] 34-000410-00	HR816 ■ 24-30653-85/0	NA5124 32x47x10mm, PTFE (50-319433-00) NA5106 ■ 35x48x10mm, PTFE (50-319430-00) LK5012 ■ [3] [85] 85x132x15.7mm, ACM (50-319535-00)	HL5034 [245] ■	
HBS363 ⊕ (22-33038B) M10x1.50x122mm (x10)	JD5873 ■ 50-030353-00 (FPM) JD5813 ■ 31-030233-00	JM7048 50-030354-00 (Rubber/Metal) AXW	HR397 [57] 34-000410-00	HR791 ■ 24-30614-76/0	NA5124 32x47x10mm, PTFE (50-319433-00) NA5106 ■ 35x48x10mm, PTFE (50-319430-00) LK5008 ■ [3] 85x131x15.7mm, PTFE (50-319472-00)	HL5034 [245] ■	











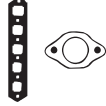

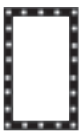

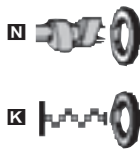



VW



KWPS



Touran 2.0L TDI Diesel		02/03 →		276		AG8970 (MLS), 1.55mm, 1 Hole		EF5380	
Touran 2.0L TDI 16V Diesel		08/03 →				30-030249-00		22-30369-00/0	
AZV	1968	4	81.00	PDi, SOHC	100/136	AG8800 (MLS), 1.63mm, 2 Holes <i>(30-030213-00)</i>			
BKD	1968	4	81.00	PDi, DOHC	103/140	AG8960 (MLS), 1.71mm, 3 Holes <i>(30-030248-00)</i>			
Touran 2.0L TDI Diesel		12/05 →		277		AG8970 (MLS), 1.55mm, 1 Hole		EF5380	
BMN	1968	4	81.00	Direct Injection, DOHC	125/170	30-030249-00		22-30369-00/0	
						AG8800 (MLS), 1.63mm, 2 Holes <i>(30-030213-00)</i>			
						AG8960 (MLS), 1.71mm, 3 Holes <i>(30-030248-00)</i>			
Touran 2.0L TDI Diesel		12/05 →		278		AG9630 (MLS), 1.45mm, 1 Hole		EF5380	
BMM	1968	4	81.00	Direct Injection, DOHC	103/140	30-030349-00		22-30369-00/0	
						AG9640 (MLS), 1.53mm, 2 Holes			
						AG9650 (MLS), 1.61mm, 3 Holes			
Transporter 1.6L D Diesel		01/81 →07/87		279		BH720 (Fibre), 1.50mm, 2 Holes		DD501▲ [83]	
CS	1588	4	76.50		37/50	30-024428-10		21-25753-26/0	
						→Eng.CS 000 338			
						BH730 (Fibre), 1.60mm, 3 Notches			
						30-024429-10			
						→Eng.CS 000 338			
						BT020 (Fibre), 1.53mm, 1 Notch			
						30-025240-10			
						Eng.CS 000 339 →			
Transporter 1.6L TD Diesel		08/84 →07/92		280		BT020 (Fibre), 1.53mm, 1 Notch		DD502▲ [83]	
Transporter 1.6L TD Syncro Diesel		03/86 →07/92				30-025240-10		(21-25753-27/0)	
JX	1588	4	76.50		50/68				
Transporter 1.7L D Diesel		08/85 →07/92		281				DT590▲	
KY	1716	4	79.50		42/57			EG873	
Transporter 1.8L		12/90 →07/92		282		BW790 (Fibre)		DW790	
PD	1781	4	81.00		49/67	30-027049-00		21-27049-20/0	
Transporter 1.9L		08/82 →07/92		283		BM690 (Steel) (x4)		DM690○ (x2)	
Transporter 1.9L Syncro		11/84 →07/92				30-024758-00		21-24750-22/0	
DH	1913	4	94.00	OHV, Boxer	60/81			GM690○	
GW	1913	4	94.00	OHV, Boxer	66/89			20-24750-01/0	
DF	1915	4	94.00		44/60				
DG	1915	4	94.00	OHV, Boxer	57/77				

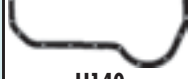









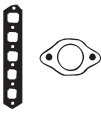

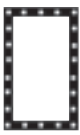

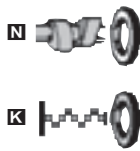











								
HBS364 Ⓞ (22-39032B) M12x1.75x149mm (x10)	JD5805 ■ 50-030225-00 JD5806 ■ 31-030226-00 JD5815 ■ 31-030235-00	JM7031 50-030223-00 (Rubber)	HR397 [57] 34-000410-00	HR791 ■ 24-30614-76/0	NA5124 (x2) 32x47x10mm, PTFE (50-319433-00) NA5106 ■ 35x48x10mm, PTFE (50-319430-00) LK5012 ■ [3] [85] 85x132x15.7mm, ACM (50-319535-00)	HL5034 [245] ■ KK5522 [86]		 BH720, BH730  BM690  BT020  BW790  JC152  JC243  JC478  JD170  JD278  JE160  PA459  HL457  JM986  JJ140
HBS364 Ⓞ (22-39032B) M12x1.75x149mm (x10)	JD5805 ■ 50-030225-00 JD5806 ■ 31-030226-00		HR397 [57] 34-000410-00	HR791 ■ 24-30614-76/0	NA5124 (x2) 32x47x10mm, PTFE (50-319433-00) NA5106 ■ 35x48x10mm, PTFE (50-319430-00) LK5012 ■ [3] [85] 85x132x15.7mm, ACM (50-319535-00)	HL5034 [245] ■ KK5522 [86]		
HBS300 Ⓞ (22-33034B) M12x1.75x166mm (x10)	JD170 ■ 31-026556-10		HR397 [57] 34-000410-00	HR816 ■ 24-30653-85/0	NA5124 32x47x10mm, PTFE (50-319433-00) NA5106 ■ 35x48x10mm, PTFE (50-319430-00) LK5012 ■ [3] [85] 85x132x15.7mm, ACM (50-319535-00)			
HBS018 Ⓞ (22-39024B) M12x1.75x115mm (x10)	JC478 ■ 31-026397-00 JC152 ■ (x4) 31-026555-00	HL457 ■ [79] 24-25753-01/0 (Cork) HM5053 ■ [80] 24-28543-00/0 (ACM)	JJ140 (31-026554-10)	HR569 ■ 24-30667-00/0	NA5001 32x47x10mm, FPM (50-303185-50) NA5001 ■ 32x47x10mm, FPM (50-303185-50) NA5133 ■ 85x105x11mm, FPM (24-30727-87/0)	HL5020 [245] ■ KA5020 [13] NA5278 [54]		
HBS018 Ⓞ (22-39024B) M12x1.75x115mm (x10)	JC243 ■ (31-026727-00) JC152 ■ (x4) 31-026555-00 JE5075 (31-027178-00)	HL457 ■ [79] 24-25753-01/0 (Cork) HM5053 ■ [80] 24-28543-00/0 (ACM)	JJ140 (31-026554-10)	HR569 ■ 24-30667-00/0	NA5001 32x47x10mm, FPM (50-303185-50) NA5001 ■ 32x47x10mm, FPM (50-303185-50) NA5133 ■ 85x105x11mm, FPM (24-30727-87/0)	HL5020 [245] ■ KA5020 [13] NA5278 [54]		
HBS018 Ⓞ (22-39024B) M12x1.75x115mm (x10)	JD278 ■ (31-025755-20) JC152 ■ (x4) 31-026555-00	HL457 ■ [79] 24-25753-01/0 (Cork) HM5053 ■ [80] 24-28543-00/0 (ACM)	JJ140 (31-026554-10)	HR569 ■ 24-30667-00/0	NA5001 32x47x10mm, FPM (50-303185-50) NA5001 ■ 32x47x10mm, FPM (50-303185-50) NA5133 ■ 85x105x11mm, FPM (24-30727-87/0)	HL5020 [245] ■ KA5020 [13] NA5278 [54]		
HBS043 Ⓞ (22-39001B) M11x1.50x95mm (x10)	JC478 ■ 31-026397-00 PA459 ■ 50-024870-00 (NBR) JC152 ■ (x4) 31-026555-00 JE160 (31-024869-00)	HL457 ■ [79] 24-25753-01/0 (Cork) HM5053 ■ [80] 24-28543-00/0 (ACM)	JJ140 (31-026554-10)	HR569 ■ 24-30667-00/0	NA5001 32x47x10mm, FPM (50-303185-50) NA5001 ■ 32x47x10mm, FPM (50-303185-50) NA5133 ■ 85x105x11mm, FPM (24-30727-87/0)	HL5020 [245] ■		
	JD236 ■ (x4) (32-206582-10)	JM986 (x2) (31-022534-00)			NB953 ■ 75x95x12mm, FPM (50-319170-00)			



KW/PS



Transporter 1.9L D Diesel					07/90 → 04/03	284	BV850 (MLS), 1.53mm, 1 Hole 30-028545-00 BV860 (MLS), 1.57mm, 2 Holes 30-028546-00 BV870 (MLS), 1.61mm, 3 Holes 30-028547-00		DV850▲ 21-26557-20/0	EA800 22-26384-20/0
1X	1896	4	79.50			44/60				
Transporter 1.9L TD Diesel					10/92 → 04/03	285	BV850 (MLS), 1.53mm, 1 Hole 30-028545-00 BV860 (MLS), 1.57mm, 2 Holes 30-028546-00 BV870 (MLS), 1.61mm, 3 Holes 30-028547-00		DV850▲ 21-26557-20/0 → Eng.ABL 076 000 DV851▲ 21-26557-21/0 Eng.ABL 076 001 →	EA800 22-26384-20/0
ABL	1896	4	79.50			50/68				
Transporter 1.9L TDI Diesel					04/03 →	286	AF5381 (MLS), 1.49mm, 1 Hole 30-030098-10 AF5391 (MLS), 1.57mm, 2 Holes 30-030099-10 AF5401 (MLS), 1.65mm, 3 Holes 30-030100-10		CC5230▲ 21-29463-21/0	EB5370 [8] 22-29314-00/0
AXC AXB	1896 1896	4 4	79.50 79.50			63/85 77/105				
Transporter 1.9L TDI Diesel					06/06 →	287	AF5381 (MLS), 1.49mm, 1 Hole 30-030098-10 AF5391 (MLS), 1.57mm, 2 Holes 30-030099-10 AF5401 (MLS), 1.65mm, 3 Holes 30-030100-10			EF5380 22-30369-00/0
BRS	1896	4	79.50	Direct Injection, SOHC		75/102				
Transporter 2.0L					04/03 →	288	AB5370 (MLS) 30-029314-00			EB5370 [8] 22-29314-00/0
AXA	1984	4	82.50			85/116				
Transporter 2.0L					07/90 → 04/03	289	BW790 (Fibre) 30-027049-00		DW790 21-27049-20/0	EA800 22-26384-20/0
AAC	1968	4	81.00	Digifant		62/84				
Transporter 2.1L					08/85 → 07/92	290	BM690 (Steel) (x4) 30-024758-00		DM690 (x2) 21-24750-22/0	GM690 (x2) 20-24750-01/0
Transporter 2.1L i					07/89 → 07/92					
Transporter 2.1L Syncro					08/85 → 07/92					
SR	2109	4	94.00			64/87				
SS	2109	4	94.00			68/92				
MV	2109	4	94.00	Boxer		70/95				
DJ	2109	4	94.00	Boxer		82/111				
Transporter 2.4L D Diesel					08/97 → 04/03	291	AF5340 (MLS), 1.53mm, 1 Hole 30-027550-20 AF5350 (MLS), 1.57mm, 2 Holes 30-027551-20 AF5360 (MLS), 1.61mm, 3 Holes 30-027552-20		CA5470▲ 21-27046-21/0	EA5470 22-27042-01/0
AJA	2370	5	79.50			55/75				











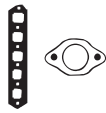

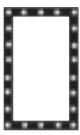

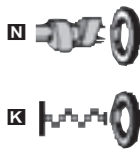





								
HBS018 ® (22-39024B) M12x1.75x115mm (x10)	JD170 ■ 31-026556-10 JC152 ■ (x4) 31-026555-00 ☉ JE160 (31-024869-00)	JN914 50-026557-10 HM5058 ■ 24-26557-00/0	JH5023 (31-029043-00)	HR569 ■ 24-30667-00/0	NA5001 32x47x10mm, FPM (50-303185-50) NA5001 ■ 32x47x10mm, FPM (50-303185-50) NA5133 ■ 85x105x11mm, FPM (24-30727-87/0) LK5006 ■ [3] 85x131x16mm, PTFE (50-319448-00)	HL5020 [245]■ NA5278 [54]		 AB5370  JH5023  AF5340  AF5350  AF5360  BM690  BV850, BV860, BV870  BW790  JC152  JD170  JD312  JD483  JD5292  JD5293  JD600  JE160  HL457  JM5103  JM986  JN914
HBS018 ® (22-39024B) M12x1.75x115mm (x10)	JD170 ■ 31-026556-10 JC152 ■ (x4) 31-026555-00	JN914 50-026557-10 HM5058 ■ 24-26557-00/0	JH5023 (31-029043-00) →Eng.ABL 076 000 JJ609 (50-027500-00) (ACM) Eng.ABL 076 001→	HR569 ■ 24-30667-00/0 000 HR816 ■ 24-30653-85/0 Eng.ABL 076 001→	NA5001 32x47x10mm, FPM (50-303185-50) NA5001 ■ 32x47x10mm, FPM (50-303185-50) NA5133 ■ 85x105x11mm, FPM (24-30727-87/0) LK5006 ■ [3] 85x131x16mm, PTFE (50-319448-00)	HL5020 [245]■ NA5278 [54]		
HBS300 ® (22-33034B) M12x1.75x166mm (x10)	JD170 ■ 31-026556-10 JD600 ■ 31-028454-00	JM5203 50-029934-00	HR397 [57] 34-000410-00	HR816 ■ 24-30653-85/0	NA5124 32x47x10mm, PTFE (50-319433-00) NA5106 ■ 35x48x10mm, PTFE (50-319430-00) LK5003 ■ [3] 85x131x15.7mm, PTFE (50-319434-00)	HL5034 [245]■		
HBS300 ® (22-33034B) M12x1.75x166mm (x10)	JD170 ■ 31-026556-10 JD600 ■ 31-028454-00		HR397 [57] 34-000410-00	HR816 ■ 24-30653-85/0	NA5124 32x47x10mm, PTFE (50-319433-00) NA5106 ■ 35x48x10mm, PTFE (50-319430-00) LK5012 ■ [3] [85] 85x132x15.7mm, ACM (50-319535-00)			
HBS246 ® (22-33024B) M10x1.50x120mm (x10)	JD5292 ■ ■ (31-029815-00) JD5293 ■ (31-029816-00)	JM5103 (50-029547-00)	HR397 [57] 34-000410-00	HR816 ■ 24-30653-85/0	NA5124 32x47x10mm, PTFE (50-319433-00) NA5106 ■ 35x48x10mm, PTFE (50-319430-00) LK5003 ■ [3] 85x131x15.7mm, PTFE (50-319434-00)	HL5034 [245]■		
HBS018 ® (22-39024B) M12x1.75x115mm (x10)	JD483 ■ (31-027352-00) JC152 ■ (x4) 31-026555-00	HL457 ■ [79] 24-25753-01/0 (Cork) HM5053 ■ [80] 24-28543-00/0 (ACM)	JH5023 (31-029043-00)	HR569 ■ 24-30667-00/0	NA5001 32x47x10mm, FPM (50-303185-50) NA5001 ■ 32x47x10mm, FPM (50-303185-50) NA5133 ■ 85x105x11mm, FPM (24-30727-87/0)	HL5020 [245]■ NA5278 [54]		
	JD237 ■ (x2) (31-024875-10) JD236 ■ (x4) (32-206582-10)	JM986 (x2) (31-022534-00)			NB953 ■ 75x95x12mm, FPM (50-319170-00)			
HBS021 ® (22-39003B) M12x1.75x115mm (x12)	JD312 ■ 31-027043-00 JC152 ■ (x5) 31-026555-00		JJ501 (31-027042-00)	HR615 ■ 24-30667-05/0	NA5001 32x47x10mm, FPM (50-303185-50) NB716 ■ 35x48x10mm, FPM (50-306067-50) NA5133 ■ 85x105x11mm, FPM (24-30727-87/0) →Eng.AJA 028 554 LK5006 ■ [3] 85x131x16mm, PTFE (50-319448-00) Eng.AJA 228 555→			



KW/PS

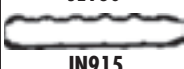

Transporter 2.4L D Diesel		07/90 → 04/03		292		AF5340 (MLS), 1,53mm, 1 Hole 30-027550-20		DW830▲ 21-27046-20/0 → Ch.70-R-160 000		EA5470 22-27042-01/0	
Transporter 2.4L D Syncro Diesel		10/92 → 04/03				AF5350 (MLS), 1,57mm, 2 Holes 30-027551-20		CA5470▲ 21-27046-21/0 Ch.70-R-160 001 →			
AAB	2370	5	79.50		57/77	AF5360 (MLS), 1,61mm, 3 Holes 30-027552-20					
Transporter 2.5L		11/90 → 04/03		293		BV880 (Fibre) 30-026422-00		DV880 21-26422-20/0 AAF, ACU, AEN		EA5470 22-27042-01/0	
Transporter 2.5L Syncro		10/92 → 04/03									
AAF	2461	5	81.00	Digifant	81/110						
ACU	2461	5	81.00	SOHC	81/110						
AEN	2461	5	81.00		81/110						
AEU	2461	5	81.00	SOHC	81/110						
Transporter 2.5L		08/96 → 04/03		294		BV880 (Fibre) 30-026422-00				EA5470 22-27042-01/0	
Transporter 2.5L Syncro		07/96 → 04/03									
AET	2461	5	81.00	SOHC	81/110						
APL/AVT	2461	5	81.00		85/116						
Transporter 2.5L TDI Diesel		09/95 → 04/03		295		AF5310 (MLS), 1,51mm, 1 Hole 30-027510-40				EA5470 22-27042-01/0	
Transporter 2.5L TDI Syncro Diesel		09/95 → 04/03				AF5320 (MLS), 1,57mm, 2 Holes 30-027511-40					
AJT/AYY	2461	5	81.00		65/88	AF5330 (MLS), 1,61mm, 3 Holes 30-027512-40					
ACV	2461	5	81.00		74/100						
AUF	2461	5	81.00		75/102						
AXL	2461	5	81.00	Direct Injection, SOHC	75/102						
AYC	2461	5	81.00	Direct Injection	75/102						
Transporter 2.5L TDI Diesel		05/98 → 04/03		296		AF5310 (MLS), 1,51mm, 1 Hole 30-027510-40					
AHY/AXG	2461	5	81.00		111/151	AF5320 (MLS), 1,57mm, 2 Holes 30-027511-40					
						AF5330 (MLS), 1,61mm, 3 Holes 30-027512-40					
Transporter 2.5L TDI Diesel		04/03 →		297		AG8920 (MLS), 1.27mm, 1 Hole 30-030244-00					
Transporter 2.5L TDI 4motion Diesel		07/04 →				AG8820 (MLS), 1.35mm, 2 Holes 30-030215-00					
AXE	2461	5	81.00	PDi	128/174	AG8930 (MLS), 1.43mm, 3 Holes (30-030245-00)					
BPC	2461	5	81.00	Direct Injection, SOHC	128/174						
Transporter 2.8L V6		04/00 → 04/03		298		AG5000 (MLS) (30-030123-00)		CG5000 21-30123-00/0		EG5000	
Transporter 2.8L VR6		06/00 → 04/03									
AMV	2792	6	81.00	DOHC, V6	150/204						

								
HBS021 ⊗ (22-39003B) M12x1.75x115mm (x12)	JD312 ■ 31-027043-00 JC152 ■ (x5) 31-026555-00 ⊗ JE160 (31-024869-00)	JN915 50-027046-00 →Ch.70-R160 000	JJ501 (31-027042-00)	HR615 ■ 24-30667-05/0	NA5001 (x2) 32x47x10mm, FPM (50-303185-50) NB716 ■ 35x48x10mm, FPM (50-306067-50) NA5133 ■ 85x105x11mm, FPM (24-30727-87/0)	NA5278 [54]		 AF5310  AF5320  AF5330  AF5340  AF5350  AF5360  AG5000
HBS021 ⊗ (22-39003B) M12x1.75x115mm (x12)	JD171 ■ 31-027048-00 JC152 ■ (x5) 31-026555-00	JN915 50-027046-00 AAF, ACU, AEN	JJ501 (31-027042-00)	HR615 ■ 24-30667-05/0	NA5001 (x2) 32x47x10mm, FPM (50-303185-50) NB716 ■ 35x48x10mm, FPM (50-306067-50) NA5133 ■ 85x105x11mm, FPM (24-30727-87/0) →Eng.AEU 002 001 AAF, ACU, AEN LK5006 ■ [3] 85x131x16mm, PTFE (50-319448-00) Eng.AEU 002 002→	NA5278 [54]		 BV880  JC152  JD171  JD312  JE160  JN915  JJ501
HBS021 ⊗ (22-39003B) M12x1.75x115mm (x12)	JD171 ■ 31-027048-00 JC152 ■ (x5) 31-026555-00		JJ501 (31-027042-00)	HR615 ■ 24-30667-05/0	NA5124 ■ 32x47x10mm, PTFE (50-319433-00) NB716 ■ 35x48x10mm, FPM (50-306067-50) NA5133 ■ 85x105x11mm, FPM (24-30727-87/0) →Eng.AET 017 277 LK5006 ■ [3] 85x131x16mm, PTFE (50-319448-00) Eng.AET 017 278→ APL, AVT	NA5278 [54]		
HBS021 ⊗ (22-39003B) M12x1.75x115mm (x12)	JD312 ■ 31-027043-00 JC152 ■ (x5) 31-026555-00		JJ501 (31-027042-00)	HR615 ■ 24-30667-05/0	NA5001 (x2) 32x47x10mm, FPM (50-303185-50) ACV NA5124 ■ 32x47x10mm, PTFE (50-319433-00) AJT AYC AYY AUF AXL NB716 ■ 35x48x10mm, FPM (50-306067-50) NA5133 ■ 85x105x11mm, FPM (24-30727-87/0) →Eng.ACV 115 395 LK5006 ■ [3] 85x131x16mm, PTFE (50-319448-00) Eng.ACV 115 396→ AJT AYC AYY AUF AXL	NA5278 [54]		
HBS021 ⊗ (22-39003B) M12x1.75x115mm (x12)	JD312 ■ 31-027043-00 JC152 ■ (x5) 31-026555-00		JJ501 (31-027042-00) →Eng.AHY 005 000	HR615 ■ 24-30667-05/0	NA5124 ■ 32x47x10mm, PTFE (50-319433-00) NB716 ■ 35x48x10mm, FPM (50-306067-50) LK5006 ■ [3] 85x131x16mm, PTFE (50-319448-00)	NA5278 [54]		
		HR397 [57] 34-000410-00	HR397 [57] 34-000410-00					
		JM7045 50-030133-00 (Rubber)	HR397 [57] 34-000410-00	HR5062 ■ 24-30614-73/0	NA5106 ■ 35x48x10mm, PTFE (50-319430-00)			



KW/PS



Transporter 2.8L VR 6				11/95 → 04/00	299	AA5430 (Fibre)		EC340 (22-28817-00/0) → Eng.AES 009 433
AES	2792	6	81.00	SOHC, V6	103/140	30-027920-00 → Eng.AES 009 433		
Transporter 3.2L 4motion				11/03 → 06/06	300	AG9610 (MLS)	CG9610	
Transporter 3.2L V6				04/03 → 06/04		30-030350-00	21-30350-00/0	
BDL	3189	6	84.00	DOHC, V6	170/231			
BKK	3189	6	84.00		173/235			
Vento 1.4L				11/91 → 09/98	301	BZ180 (MLS), 0.50mm	DL572	EB961 [8] 22-28897-03/0
ABD	1390	4	75.00	Monomotronic	40/44/ 55/60	30-027910-10 AEX	21-24813-25/0 → 07/94	AEX
AEX	1390	4	76.50	Injection, SOHC	40/44/ 54/60	BL570 (Fibre), 1.73mm 30-024813-20 ABD	ABD DZ181 21-27910-21/0 AEX DL573 (21-24813-28/0) Eng.ABD 558 155 → DL574 21-24813-27/0 08/94 → → Eng.ABD 558 154 ABD	EV460 22-26516-01/0 ABD
Vento 1.6L				09/92 → 09/98	302	BY620 (Fibre)	DY620	EB961 [8] 22-28897-03/0
ABU	1598	4	76.50	Monomotronic	55/75	30-027905-00	21-27905-20/0	AEE
AEA	1598	4	76.50	SOHC	55/75	ABU	ABU	
AEE	1598	4	76.50	Injection, SOHC	55/75	BZ180 (MLS), 0.50mm 30-027910-10 AEA, AEE	DZ180 21-27910-20/0 AEA DZ181 21-27910-21/0 AEE	EV460 22-26516-01/0 ABU, AEA
Vento 1.6L				10/94 → 09/98	303	AY940 (MLS)	CY940	EB970
AEK/AFT	1595	4	81.00	SOHC	74/100	30-028383-00	21-28383-20/0 AEK CY941 21-28383-21/0 AFT	22-27500-01/0 AEK

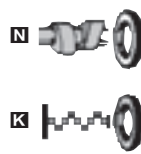
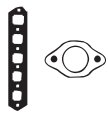

HBS077 [22-39012B] M11x1.50x85mm (x7) M11x1.50x144mm (x3) M11x1.50x119mm (x10) →Eng.AES 009 433	JA5068 [31-027917-00] JA5069 [28] [31-027913-00] JD5109 [29] [31-027914-00]		JH5059 [50-028817-00] →Eng.AES 009 433 HR397 [57] 34-000410-00 Eng.AES 009 434→	HR602 24-30670-61/0 NA5133 [24-30727-87/0] 85x105x11mm, FPM NA5133 [24-30727-87/0] 85x105x11mm, FPM	
HBS466 [22-33039B]	JD5874 50-030351-00 (FPM)	JM7045 50-030133-00 (Rubber)	HR397 [57] 34-000410-00	HR5062 24-30614-73/0 NA5106 [50-319430-00] 35x48x10mm, PTFE	
HBS043 [22-39001B] M11x1.50x95mm (x10) ABD HBS075 [22-39011B] M11x1.50x110mm (x10) AEX	JD246 [31-026474-20] ABD JD597 50-350355-00 AEX JC259 (x2) 31-026229-10 →07/94 ABD JD601 31-028644-00 ABD 08/94 → AEX	JN641 50-025265-10 →Eng.ABD 558 154 JP074 50-027907-00 Eng.ABD 558 155→ AEX HM5062 24-27907-00/0 Eng.ABD 558 155→ AEX	HR397 [57] 34-000410-00 AEX JJ183 [31-026516-10] ABD	HR569 24-30667-00/0 ABD →07/94 HR816 24-30653-85/0 ABD 08/94→, AEX NA5001 [50-303185-50] 32x47x10mm, FPM NA5001 [50-303185-50] 32x47x10mm, FPM →Eng.AEX 908 121 NA5133 [24-30727-87/0] 85x105x11mm, FPM →Eng.AEX 908 121 NA5185 [50-319489-00] 32x42x6mm, FPM Eng.AEX 908 122→ LK5006 [3] [50-319448-00] 85x131x16mm, PTFE Eng.AEX 908 122→	HL5020 [245] →Eng.AEX 908 121 ABD KA5025 [13]
HBS075 [22-39011B] M11x1.50x110mm (x10)	JD487 [31-027908-00] ABU, AEA JD597 50-350355-00 AEE JD601 31-028644-00 JE154	JN641 50-025265-10 ABU JP074 50-027907-00 AEA, AEE HM5062 24-27907-00/0 AEA, AEE	HR397 [57] 34-000410-00 AEE JJ183 [31-026516-10] ABU, AEA	HR816 24-30653-85/0 NA5001 [50-303185-50] 32x47x10mm, FPM NA5001 [50-303185-50] 32x47x10mm, FPM →Eng.AEE 562 757 ABU, AEA NA5133 [24-30727-87/0] 85x105x11mm, FPM →Eng.AEE 562 757 ABU, AEA NA5185 [50-319489-00] 32x42x6mm, FPM Eng.AEE 562 758→ LK5006 [3] [50-319448-00] 85x131x16mm, PTFE Eng.AEE 562 758→	HL5020 [245] →Eng.AEE 562 757
HBS043 [22-39001B] M11x1.50x95mm (x10)	JD599 [31-027926-00] JD600 31-028454-00 JF205 [31-025070-00]	JP024 50-027505-00	HR569 24-30667-00/0 AEK HR816 24-30653-85/0 AFT	NA5001 [50-303185-50] 32x47x10mm, FPM NA5001 [50-303185-50] 32x47x10mm, FPM NA5133 [24-30727-87/0] 85x105x11mm, FPM	HL5020 [245] NA5278 [54]

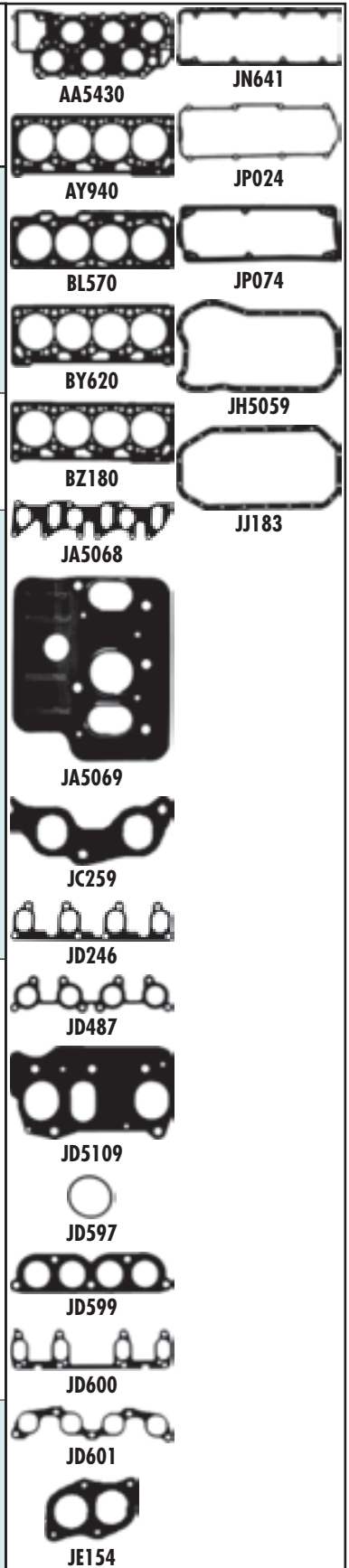



KW/PS



Vento 1.8L					11/91 → 09/98	304			
AAM	1781	4	81.00	Monomotronic	55/75	BM360 (Fibre) 30-026807-30 →Eng.AAM 408 197 BZ910 (MLS) 30-027935-00 Eng.AAM 408 198 →	DM366 21-26807-26/0 →Ch.1H-P-490 000 →Ch.1H-PB-140 000 →Ch.1H-PW-490 000 DM367 21-26807-30/0 Ch.1H-P-480 001 → Ch.1H-PB-140 001 → Ch.1H-PW-490 001 → →Eng.AAM 408 197 DZ910 21-27935-20/0 Eng.AAM 408 198 →		
Vento 1.8L					11/91 → 09/98	305			
ABS	1781	4	81.00	Monomotronic	66/89	BM360 (Fibre) 30-026807-30 →Eng.ABS 935 645 →Eng.ADZ 011 565 BZ910 (MLS) 30-027935-00 Eng.ABS 935 646 → Eng.ADZ 011 566 →	DM366 21-26807-26/0 →Ch.1 HPB 140 000 →Ch.1 HPP 490 000 →Ch.1 HPW 490 000 DM367 21-26807-30/0 Ch.1 HPB 140 001 → Ch.1 HPP 490 001 → Ch.1 HPW 490 001 → →Eng.ABS 935 645 →Eng.ADZ 011 565 DZ910 21-27935-20/0 Eng.ABS 935 646 → Eng.ADZ 011 566 →		
ADZ	1781	4	81.00	SOHC	66/89				

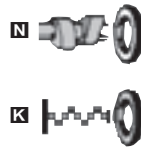
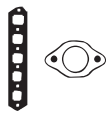

BM360



BZ910



JC152



JC478



JD5235



PA459



HL457



JP024



JJ609

HBS043Ⓢ
(22-39001B)
M11x1.50x95mm (x10)
→Eng.AAM 408 197

JC478■
31-026397-00
→Eng.AAM 408 197
PA459■
50-024870-00
(NBR)
→Eng.AAM 408 197
JD5235■
(31-028554-00)
Eng.AAM 408 198 →
JC152■ (x4)
31-026555-00
Ⓢ**JE5076**
(31-028373-00)

JP024
50-027505-00
Ch.1H-P-490
001 →
Ch.1H-PB-140
001 →
Ch.1H-PW-490
001 →
HL457■ [79]
24-25753-01/0
(Cork)
→Ch.1H-P-490
000
→Ch.1H-PB-140
000
→Ch.1H-PW-490
000
HM5053■ [80]
24-28543-00/0
(ACM)
→Ch.1H-P-490
000
→Ch.1H-PB-140
000
→Ch.1H-PW-490
000

JJ609
(50-027500-00)
(ACM)

HR569■
24-30667-00/0
→Eng.AAM 408
197
HR816■
24-30653-85/0
Eng.AAM 408
198 →

■ **NA5001** 32x47x10mm, FPM
(50-303185-50)
■ **NA5001**■ 32x47x10mm, FPM
(50-303185-50)
■ **NA5133**■ 85x105x11mm, FPM
(24-30727-87/0)

HL5020 [245]■

HBS043Ⓢ
(22-39001B)
M11x1.50x95mm (x10)

JC478■
31-026397-00
→Eng.ABS 935 645
→Eng.ADZ 011 565
PA459■
50-024870-00
(NBR)
→Eng.ABS 935 645
→Eng.ADZ 011 565
JD5235■
(31-028554-00)
Eng.ABS 935 646 →
Eng.ADZ 011 565 →
JC152■ (x4)
31-026555-00
Ⓢ**JE5076**
(31-028373-00)

JP024
50-027505-00
Ch.1 HPB 140
001 →
Ch.1 HPP 490
001 →
Ch.1 HPW 490
001 →
HL457■ [79]
24-25753-01/0
(Cork)
→Ch.1 HPB 140
000
→Ch.1 HPP 490
000
→Ch.1 HPW 490
000
HM5053■ [80]
24-28543-00/0
(ACM)
→Ch.1 HPB 140
000
→Ch.1 HPP 490
000
→Ch.1 HPW 490
000

JJ609
(50-027500-00)
(ACM)

HR569■
24-30667-00/0
→Eng.ABS 935
645
→Eng.ADZ 011
565
HR816■
24-30653-85/0
Eng.ABS 935
646 →
Eng.ADZ 011
566 →

■ **NA5001** 32x47x10mm, FPM
(50-303185-50)
■ **NA5001**■ 32x47x10mm, FPM
(50-303185-50)
■ **NA5133**■ 85x105x11mm, FPM
(24-30727-87/0)

HL5020 [245]■



KW/PS



Vento 1.9L D Diesel		11/91 → 09/98			306	BV850 (MLS), 1.53mm, 1 Hole 30-028545-00 BV860 (MLS), 1.57mm, 2 Holes 30-028546-00 BV870 (MLS), 1.61mm, 3 Holes 30-028547-00	DV850▲ 21-26557-20/0 →Eng.1Y 580 000 DV851▲ 21-26557-21/0 Eng.1Y 580 001 →	ECO30 [8] 22-26384-04/0
1Y	1896	4	79.50		47/50/ 64/68			
Vento 1.9L SDI Diesel		04/97 → 09/98			307	BX800 (MLS), 1.45mm, 1 Hole 30-028686-00 BX810 (MLS), 1.53mm, 2 Holes 30-028687-00 BX820 (MLS), 1.61mm, 3 Holes 30-028688-00	DX801▲ 21-27921-21/0	ECO30 [8] 22-26384-04/0
AEY	1896	4	79.50	SDi	47/64			
Vento 1.9L TD Diesel		11/91 → 09/98			308	BV850 (MLS), 1.53mm, 1 Hole 30-028545-00 BV860 (MLS), 1.57mm, 2 Holes 30-028546-00 BV870 (MLS), 1.61mm, 3 Holes 30-028547-00	DV850▲ 21-26557-20/0 →Eng.AAZ 678 000 DV851▲ 21-26557-21/0 Eng.AAZ 678 001 →	ECO30 [8] 22-26384-04/0
AAZ	1896	4	79.50		55/75			
Vento 1.9L TDI Diesel		09/93 → 09/98			309	BX800 (MLS), 1.45mm, 1 Hole 30-028686-00 BX810 (MLS), 1.53mm, 2 Holes 30-028687-00 BX820 (MLS), 1.61mm, 3 Holes 30-028688-00	DX800▲ 21-27921-20/0 →Eng.1Z 720 000 AHU DX801▲ 21-27921-21/0 Eng.1Z 720 001 → ALE	ECO30 [8] 22-26384-04/0
1Z AHU/ALE	1896 1896	4 4	79.50 79.50	SOHC	66/89 66/89			
Vento 1.9L TDI Diesel		04/96 → 09/98			310	BX800 (MLS), 1.45mm, 1 Hole 30-028686-00 BX810 (MLS), 1.53mm, 2 Holes 30-028687-00 BX820 (MLS), 1.61mm, 3 Holes 30-028688-00	DX800▲ 21-27921-20/0 →Eng.AFN 002 000 DX801▲ 21-27921-21/0 Eng.AFN 002 001 →	ECO30 [8] 22-26384-04/0
AFN	1896	4	79.50	SOHC	81/110			
Vento 2.0L		11/91 → 09/98			311	BT810 (Fibre) 30-027257-20 2E BY750 (MLS) 30-027930-00 ADY, AGG, AKR	DT816 21-27257-24/0 2E (→09.1994) DY753 21-27930-23/0 10/94 → ADY, AGG, AKR	ES471 2E (→09.1994) EB970 22-27500-01/0 10/94 → ADY, AGG, AKR
2E ADY AGG AKR	1984 1984 1984 1984	4 4 4 4	82.50 82.50 82.50 82.50	Digifant OHV SOHC	85/115 85/116 85/116 85/116			

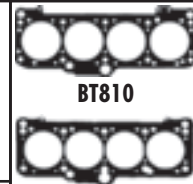
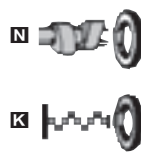
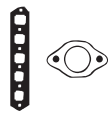

BT810



BV850, BV860, BV870



BX800, BX810, BX820



BY750



JC152



JD170



JD483



JN914



JP003



JP024



JH5023



JJ140



JJ576



JJ609

HBS018Ⓞ
(22-39024B)
M12x1.75x115mm (x10)

JD170■
31-026556-10
JC152■ (x4)
31-026555-00
Ⓞ **JE5076**
(31-028373-00)

JN914
50-026557-10
HM5058■
24-26557-00/0

JH5023
(31-029043-00)

HR569■
24-30667-00/0
→Eng.1Y 580
HR816■
24-30653-85/0
Eng.1Y 580
000→

■ **NA5001** 32x47x10mm, FPM
(50-303185-50)
■ **NA5001**■ 32x47x10mm, FPM
(50-303185-50)
■ **NA5133**■ 85x105x11mm, FPM
(24-30727-87/0)
→Eng.1Y 800 000
■ **LK5006**■ [3] 85x131x16mm, PTFE
(50-319448-00)
Eng.1Y 800 001→

HL5020 [245]■
NA5278 [54]

HBS018Ⓞ
(22-39024B)
M12x1.75x115mm (x10)

JD170■
31-026556-10
JC152■ (x4)
31-026555-00
Ⓞ **JE5076**
(31-028373-00)

JP003
50-027921-00

JJ140
(31-026554-10)

HR816■
24-30653-85/0

■ **NA5001** 32x47x10mm, FPM
(50-303185-50)
■ **NA5001**■ 32x47x10mm, FPM
(50-303185-50)
■ **NA5133**■ 85x105x11mm, FPM
(24-30727-87/0)
→Eng.AEY 050 000
■ **LK5006**■ [3] 85x131x16mm, PTFE
(50-319448-00)
Eng.AEY 050 001→

HL5020 [245]■
NA5278 [54]

HBS018Ⓞ
(22-39024B)
M12x1.75x115mm (x10)

JD170■
31-026556-10
JC152■ (x4)
31-026555-00

JN914
50-026557-10
HM5058■
24-26557-00/0

JH5023
(31-029043-00)

HR569■
24-30667-00/0
→Eng.AAZ 678
000
HR816■
24-30653-85/0
Eng.AAZ 678
001→

■ **NA5001** 32x47x10mm, FPM
(50-303185-50)
■ **NA5001**■ 32x47x10mm, FPM
(50-303185-50)
■ **NA5133**■ 85x105x11mm, FPM
(24-30727-87/0)

HL5020 [245]■
NA5278 [54]

HBS018Ⓞ
(22-39024B)
M12x1.75x115mm (x10)

JD170■
31-026556-10
JC152■ (x4)
31-026555-00

JP003
50-027921-00

JJ609
(50-027500-00)
(ACM)

HR569■
24-30667-00/0
→Eng.1Z 720
000
AHU
HR816■
24-30653-85/0
Eng.1Z 720
001→
ALE

■ **NA5001** 32x47x10mm, FPM
(50-303185-50)
■ **NA5001**■ 32x47x10mm, FPM
(50-303185-50)
■ **NA5133**■ 85x105x11mm, FPM
(24-30727-87/0)
→Eng.AHU 390 000
→Eng.ALE 576 0000
1Z
■ **LK5006**■ [3] 85x131x16mm, PTFE
(50-319448-00)
Eng.AHU 390 001→
Eng.ALE 576 001→

HL5020 [245]■
NA5278 [54]

HBS018Ⓞ
(22-39024B)
M12x1.75x115mm (x10)

JD170■
31-026556-10
JC152■ (x4)
31-026555-00

JP003
50-027921-00

JJ609
(50-027500-00)
(ACM)
→Eng.AFN 866
421
HR397 [57]
34-000410-00
Eng.AFN 866
422→

HR569■
24-30667-00/0
→Eng.AFN 002
000
HR816■
24-30653-85/0
Eng.AFN 002
001→

■ **NA5001** 32x47x10mm, FPM
(50-303185-50)
■ **NA5001**■ 32x47x10mm, FPM
(50-303185-50)
■ **NA5133**■ 85x105x11mm, FPM
(24-30727-87/0)
→Eng.AFN 576 000
■ **LK5006**■ [3] 85x131x16mm, PTFE
(50-319448-00)
Eng.AFN 576 001→

HL5020 [245]■
NA5278 [54]

HBS028Ⓞ
(22-39004B)
M11x1.50x147mm (x10)
HBS043Ⓞ
(22-39001B)
M11x1.50x95mm (x10)

JD483■
(31-027352-00)
JC152■ (x4)
31-026555-00
Ⓞ **JF205**
(31-025070-00)

JP024
50-027505-00

JJ576
(50-027808-00)
2E (→09.1994)
JJ609
(50-027500-00)
(ACM)
10/94→
ADY, AGG, AKR

HR569■
24-30667-00/0
2E
HR816■
24-30653-85/0
ADY, AGG, AKR

■ **NA5001** 32x47x10mm, FPM
(50-303185-50)
■ **NA5001**■ 32x47x10mm, FPM
(50-303185-50)
■ **NA5133**■ 85x105x11mm, FPM
(24-30727-87/0)
■ **LK5006**■ [3] 85x131x16mm, PTFE
(50-319448-00)

HL5020 [245]■
NA5278 [54]

VW



KW/PS

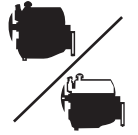

Vento 2.8L VR6

01/92 → 09/98

312

AA5430 (Fibre)

CA5430

EC340

AAA

2792

6

81.00











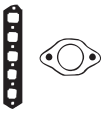

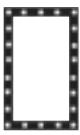

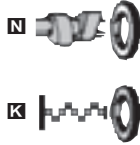
Injection, DOHC, V6

128/174

30-027920-00

21-27920-20/0
→ Eng.AAA 146 000

(22-28817-00/0)
Eng.AAA 146 001 →

							
HBS077 ® [22-390128] M11x1.50x85mm (x7) M11x1.50x144mm (x3) M11x1.50x119mm (x10)	JD5232   (31-027918-00) JA5068   (31-027917-00) JA5069  [28] (31-027913-00) JD5109  [29] (31-027914-00)	JM5030 50-027915-00 →Eng.AAA 146 000 JM5099 50-029103-00 Eng.AAA 146 001→	JH5013 (31-027911-00) →Eng.AAA 146 000 JH5059 (50-028817-00) Eng.AAA 146 000→	HR602  24-30670-61/0	NB716  35x48x10mm, FPM (50-306067-50) NA5133  85x105x11mm, FPM (24-30727-87/0)		

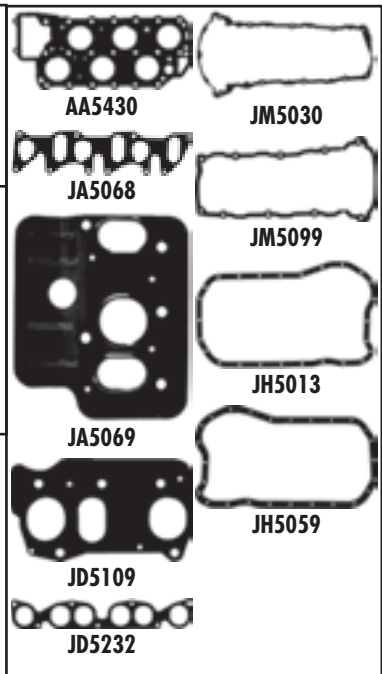











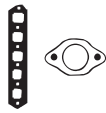

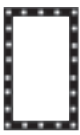

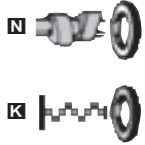

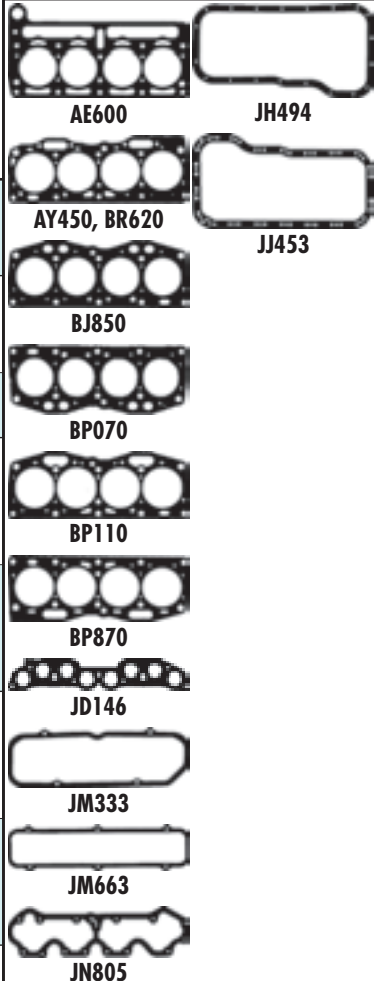





ZASTAVA



KW/PS



















101 1.1L					06/73 → 01/90	1	BP070 (Fibre)	DP070	GP070
128 A.000	1116	4	80.00	SOHC	41/44/ 56/60		(30-022199-20)		
101 1.3L					10/81 → 12/93	2	BP110 (Fibre)	DP110	
128 AR 000	1290	4	86.00		48-49/ 65-67		(30-024119-10)		
750 0.8L					01/83 → 12/91	3	AE600 (Fibre), 1.20mm	CE602	FE603 ○
100 D.0000	767	4	62.00		19/26				
Yugo 1.1L					08/89 →	4	BJ850 (Fibre)	DJ852	GJ852
138 B.0000	1116	4	80.00		44/60		(30-024779-10)	(21-24779-21/0)	
Yugo 1.1L 60 EFI					08/91 → 06/95	5			
100 GL 0.64	1116	4		Carburettor, OHV	44/60				
11 E 1.064	1116	4		Injection	44/60				
Yugo 1.3L					03/91 →	6			
13 E.3.064	1302	4		Injection, SOHC	50/68				
Yugo 1.3L 65 EFI					08/91 → 06/95	7	BP090 (Fibre)		
13 E 1.064	1302	4		Injection, SOHC	48/65		BP870 (Fibre) (30-025894-10)		
Yugo 1.4L					10/88 → 06/95	8	AY450 (Fibre) +0.20mm	DR620	GR620
160 A1.000	1372	4	80.50		52/71		BR620 (Fibre) (30-027865-00)	(21-26295-21/0)	

								
		JD146 (31-027221-10)	JM654 JM663 (31-024732-00)	JH494 (31-022554-00)	HR569  24-30667-00/0			
		JD146 (31-027221-10)	JM654 JM663 (31-024732-00)	JH494 (31-022554-00)	HR569  24-30667-00/0			
			JM333 (31-021029-00)					
HBS051  (22-17001B) M10x1.25x98mm (x5) M10x1.25x84mm (x5)	JD146 (31-027221-10)	JM654 JN805 [156] (31-026819-00)	JJ453	HR596 	 NA5187 30x52x7mm, ACM (50-319492-00)  NB818 40x56x7mm, ACM  NA5049 64x80x8mm, ACM			
HBS109  (22-17009B) M9x1.25x60mm (x1) M9x1.25x95mm (x9)								
HBS051  (22-17001B) M10x1.25x98mm (x5) M10x1.25x84mm (x5)								
HBS051  (22-17001B) M10x1.25x98mm (x5) M10x1.25x84mm (x5)								
HBS051  (22-17001B) M10x1.25x98mm (x5) M10x1.25x84mm (x5)	JD146 (31-027221-10)	JM654 JN805 [156] (31-026819-00)	JJ453	HR569  24-30667-00/0	 NA5187 30x52x7mm, ACM (50-319492-00)  NB818 40x56x7mm, ACM  NA5049 64x80x8mm, ACM	KA294 [13]		

NUMERICAL PARTS LIST









Numerische Teilenummernliste • Liste des références produits
Lista de referencias









											
AA3130	NISSAN	794	AA5840	CITROËN	218, 228, 242, 250, 274	AB5140	OPEL	828, 848, 860	AB5701	AUDI	66
	SEAT	1156, 1174		FIAT	378		VAUXHALL	1320, 1352		SEAT	1144, 1146, 1158, 1168, 1170, 1174
AA3140	SEAT	1160, 1174		PEUGEOT	936, 942, 980, 988	AB5150	FIAT	322, 332, 354, 356, 360, 382		SKODA	1186, 1188, 1196
AA5020	MITSUBISHI	764		TOYOTA	1274		LANCIA	592		VW	1448, 1454, 1466, 1496, 1498, 1520
AA5030	MAZDA	640	AA5850	CITROËN	218, 228, 242, 250, 274	AB5230	CHEVROLET	180	AB5720	FIAT	340
AA5130	FORD	456		FIAT	378		DAEWOO	292, 296		IVECO	542
	MAZDA	650, 654		PEUGEOT	936, 942, 980, 988	AB5240	OPEL	828, 832, 850	AB5730	FIAT	340
AA5390	MITSUBISHI	752, 766, 768		TOYOTA	1274		VAUXHALL	1320, 1352		IVECO	542
AA5410	SEAT	1144, 1146, 1156	AA5860	CITROËN	218, 228, 242, 250, 274	AB5260	FORD	440	AB5740	FIAT	340
	VW	1494, 1518		FIAT	378	AB5300	FORD	436, 438, 468, 474		IVECO	542
AA5420	ALFA ROMEO	14, 16, 18, 20, 22, 24, 28, 38, 40, 42		PEUGEOT	936, 942, 980, 988	AB5310	FORD	436, 438, 468, 474	AB5750	TOYOTA	1300, 1308, 1310
	FIAT	318, 370, 384		TOYOTA	1274	AB5320	FORD	436, 438, 468, 474	AB5760	TOYOTA	1250, 1260, 1266, 1268, 1272, 1294, 1300
	LANCIA	592	AA5870	CITROËN	218, 228, 242, 250, 274	AB5330	FORD	436, 438, 468, 474	AB5780	ISUZU	528
AA5430	FORD	442		FIAT	378	AB5340	FORD	436, 438, 468, 474		VAUXHALL	1358, 1360
	MERCEDES-BENZ	720		PEUGEOT	936, 942, 980, 988	AB5350	FORD	436, 438, 468, 474	AB5781	ISUZU	528
	VW	1462, 1486, 1516, 1538, 1546, 1552	AA5880	CITROËN	218, 228, 242, 250, 274	AB5360	OPEL	834, 852		VAUXHALL	1358, 1360
AA5500	SEAT	1148, 1158		FIAT	378		VAUXHALL	1322, 1354, 1378	AB5800	FORD	422, 424, 434, 436, 448, 454, 456, 464, 638
	VW	1522		PEUGEOT	936, 942, 980, 988	AB5370	SEAT	1142, 1154		MAZDA	638
AA5520	ALFA ROMEO	8, 26, 42	AA5920	LAND ROVER	614		SKODA	1188, 1194, 1196	AB5810	FORD	422, 424, 434, 436, 448, 454, 456, 464, 638
AA5540	ALFA ROMEO	6, 12, 30, 32		MG	730		VW	1452, 1482, 1484, 1498, 1500, 1512, 1536, 1542		MAZDA	638
	NISSAN	790		ROVER	1098, 1100	AB5400	LAND ROVER	612	AB5820	FORD	422, 424, 434, 436, 448, 454, 456, 464, 638
AA5550	ALFA ROMEO	6, 12, 14	AA5940	FORD	470		ROVER	1106, 1108, 1110, 1112, 1114	AB5900	LAND ROVER	610, 612
AA5560	OPEL	840, 841	AA5950	FORD	470	AB5420	VOLVO	1408, 1410, 1412, 1426, 1428	AB5910	LAND ROVER	610, 612
AA5570	ALFA ROMEO	16, 22	AA5960	FORD	470	AB5430	VOLVO	1406, 1408, 1410, 1426	AB5920	LAND ROVER	610, 612
	FIAT	320, 322, 332, 334, 352, 354, 358, 370, 384, 386	AA5970	FORD	448, 470	AB5440	VOLVO	1404, 1406, 1412, 1414, 1416, 1418, 1420, 1422, 1430, 1432	AB5980	BMW	142, 156, 162, 168
	LANCIA	594	AA5980	FORD	448, 470	AB5450	VOLVO	1406, 1412, 1414, 1418, 1420, 1422, 1430, 1434, 1436, 1438		LAND ROVER	616
	OPEL	840, 841, 880, 888, 896	AA5990	FORD	448, 470	AB5480	LAND ROVER	610, 612, 616		OPEL	876
	VAUXHALL	1332, 1370, 1374, 1378	AB5000	TOYOTA	1252, 1258, 1270, 1272, 1276, 1292, 1306, 1308		LEYLAND / LDV	628	AC5011	CITROËN	218, 219, 236, 238, 242, 244, 246, 252, 256, 260, 266, 278
AA5580	ALFA ROMEO	16, 22	AB5010	ISUZU	524		MG	732		FIAT	340, 380, 398, 400
	FIAT	320, 322, 332, 334, 352, 354, 358, 370, 384, 386		MAZDA	642	AB5490	LAND ROVER	612, 616	AC5020	FIAT	340, 380, 398, 400
	LANCIA	594		OPEL	840, 848, 856, 886	AB5540	OPEL	836, 838, 870, 884, 886, 894		LANCIA	606
	OPEL	840, 841, 880, 888, 896	AB5020	ISUZU	524		VAUXHALL	1326, 1358, 1372		PEUGEOT	972
	VAUXHALL	1332, 1370, 1374, 1378		MAZDA	642	AB5550	MERCEDES-BENZ	666, 718	AC5031	CITROËN	218, 219, 236, 238, 242, 244, 246, 252, 256, 260, 266, 278
AA5590	FIAT	356, 386		OPEL	840, 848, 856, 886	AB5560	MERCEDES-BENZ	666, 718		FIAT	340, 380, 398, 400
	LANCIA	594	AB5030	ISUZU	524	AB5570	MERCEDES-BENZ	666, 718		LANCIA	606
AA5620	VOLVO	1408, 1410, 1426, 1428		MAZDA	642	AB5610	NISSAN	782	AC5040	FIAT	340, 380, 398, 400
AA5630	VOLVO	1400		OPEL	840, 848, 856, 886	AB5630	NISSAN	806		LANCIA	606
AA5720	FIAT	356		VAUXHALL	1330, 1348, 1352, 1356, 1374	AB5660	BMW	124, 126, 170		PEUGEOT	936, 944, 948, 958, 960, 968, 972, 978, 982, 988
	LANCIA	592	AB5100	FIAT	342, 344	AB5671	OPEL	842, 844, 858, 874, 880, 882, 888, 890, 892, 896		SUZUKI	1222
AA5740	FIAT	356		IVECO	534, 538, 540, 542, 544, 546, 548		SAAB	1132		FIAT	340, 380, 398, 400
	LANCIA	592		RENAULT	1052	AB5681	OPEL	842, 844, 858, 874, 880, 882, 888, 890, 892, 896		LANCIA	606
AA5780	ALFA ROMEO	24, 30	AB5110	FIAT	342, 344		VAUXHALL	1332, 1336, 1356, 1366, 1370, 1374, 1376, 1380		PEUGEOT	972
	LANCIA	594, 600		IVECO	534, 538, 540, 542, 544, 546, 548	AB5120	FORD	426, 428		SUZUKI	1222
AA5790	ALFA ROMEO	24, 30		RENAULT	1052		MAZDA	636		FIAT	340, 380, 398, 400
	LANCIA	594, 600	AB5130	FORD	428, 430, 436, 440, 456		SAAB	1132		LANCIA	606
AA5800	ALFA ROMEO	24, 30		MAZDA	636	AB5690	NISSAN	782, 784, 786, 792, 808, 812, 818		PEUGEOT	972
	LANCIA	594, 600		TOYOTA	1274						

							
AC5051	CITROËN	218, 219, 236, 238, 242, 244, 246, 252, 256, 260, 266, 278		AC5280	AUDI	66	
	FIAT	340, 380, 398, 400			SEAT	1170, 1176	
	LANCIA	606			VW	1448, 1468, 1496, 1524	
	PEUGEOT	936, 944, 948, 958, 960, 968, 972, 978, 982, 988		AC5290	FORD	456	
	SUZUKI	1222		AC5300	BMW	128, 148	
AC5061	NISSAN	794, 806, 808		AC5310	BMW	132, 146, 148, 170, 172	
	RENAULT	1030, 1042, 1046, 1050, 1056, 1084, 1088		AC5320	BMW	152	
	VOLVO	1408, 1426			OPEL	876	
AC5070	MITSUBISHI	740, 768			VAUXHALL	1368	
	NISSAN	806, 808		AC5330	BMW	152	
	OPEL	872, 894			OPEL	876	
	RENAULT	1030, 1032, 1044, 1046, 1050, 1058, 1084			VAUXHALL	1368	
	VAUXHALL	1360, 1376		AC5340	BMW	152	
	VOLVO	1408, 1426			OPEL	876	
AC5080	MITSUBISHI	740, 768			VAUXHALL	1368	
	NISSAN	794, 806, 808		AC5350	BMW	158, 160, 164, 166, 170	
	OPEL	872, 894		AC5360	BMW	158, 160, 164, 166, 170	
	RENAULT	1030, 1032, 1044, 1046, 1050, 1058, 1084		AC5370	BMW	158, 164, 166	
	VAUXHALL	1360, 1376		AC5380	BMW	158, 164, 166	
	VOLVO	1408, 1426		AC5390	JAGUAR	552, 558	
AC5090	MITSUBISHI	740, 768		AC5400	JAGUAR	552, 558	
	OPEL	872, 894		AC5410	BMW	120, 130, 148, 166	
	RENAULT	1030, 1032, 1044, 1046, 1050, 1058, 1084		AC5420	BMW	120, 130, 148, 166	
	VAUXHALL	1360, 1376		AC5430	BMW	120, 130, 148, 166	
	VOLVO	1408, 1426		AC5440	BMW	120, 122, 124, 128, 132, 166, 172	
AC5100	RENAULT	1026, 1028, 1040, 1044, 1052, 1054, 1056, 1060, 1082, 1084, 1086		AC5460	OPEL	840, 856, 870, 880, 884, 886, 888, 894	
AC5140	FIAT	336, 350, 360, 370, 394, 396			SAAB	1130	
AC5150	FIAT	336, 350, 360, 370, 394, 396			VAUXHALL	1330, 1356, 1360, 1372, 1374, 1378	
AC5160	FIAT	336, 350, 360, 370, 394, 396		AC5470	BMW	120, 122, 124, 128, 132, 166, 172	
AC5169	FIAT	328		AC5500	JAGUAR	552, 554, 556, 558	
AC5170	FIAT	328, 360		AC5510	JAGUAR	552, 554, 556, 558	
AC5180	FIAT	336, 350, 394, 396		AC5520	MERCEDES-BENZ	690, 692, 706	
AC5190	AUDI	66		AC5530	MERCEDES-BENZ	694, 704	
	VW	1496		AC5550	CHRYSLER	184, 186, 188	
AC5200	AUDI	66		AC5560	CHRYSLER	184, 186, 188	
	VW	1496		AC5570	CHRYSLER	186, 188	
AC5210	AUDI	66		AC5580	CHRYSLER	184, 190	
	VW	1496		AC5590	CHRYSLER	184, 190	
AC5220	AUDI	66, 72		AC5600	JEEP	562, 568	
	SEAT	1142, 1150, 1160, 1170, 1176		AC5610	JEEP	564, 566, 568	
	SKODA	1190		AC5620	CHRYSLER	186	
	VW	1448, 1456, 1466, 1468, 1488, 1498, 1500, 1502, 1524, 1538			MERCEDES-BENZ 670, 672, 678, 682, 684, 710, 718, 720		
AC5260	JAGUAR	552, 554, 556, 558		AC5630	SAAB	1124, 1126, 1128, 1130, 1132	
AC5270	JAGUAR	552, 554, 556, 558		AC5640	BMW	158, 164	
				AC5650	BMW	158, 164	
				AC5660	SMART	1200	
				AC5670	SMART	1200	
				AC5680	FORD	442, 458	
				AC5690	SAAB	1126	
				AC5700	CITROËN	214, 228, 230, 258	
					PEUGEOT	924, 934, 986	
				AC5720	CHRYSLER	186	
				AC5750	FORD	446	
					NISSAN	788, 804, 818	
AC5760	FORD	446		AC5770	FORD	446	
	NISSAN	788, 804, 818			NISSAN	788, 804, 818	
AC5780	FORD	412, 450		AC5790	FORD	412, 450	
AC5790	FORD	412, 450		AC5800	FORD	438, 446, 468, 474	
AC5800	FORD	438, 446, 468, 474		AC5860	FORD	432, 438, 440, 456	
AC5860	FORD	432, 438, 440, 456			MAZDA	634	
AC5870	FORD	412, 450		AC5870	FORD	412, 450	
AC5880	FORD	412, 450		AC5880	FORD	412, 450	
AC5890	FORD	444		AC5890	FORD	444	
AC5900	BMW	134, 136, 140, 142, 148, 150, 156, 160, 162, 168, 172, 174		AC5910	FORD	442, 458, 470	
AC5910	FORD	442, 458, 470		AC5920	CHRYSLER	184, 186	
AC5920	CHRYSLER	184, 186			MINI	736	
AC5940	FORD	438, 446, 448		AC5940	FORD	438, 446, 448	
	MAZDA	634, 636			MAZDA	634, 636	
	VOLVO	1408, 1428			VOLVO	1408, 1428	
AC5960	AUDI	80, 86, 88, 90, 91		AC5960	AUDI	80, 86, 88, 90, 91	
	SKODA	1198			SKODA	1198	
	VW	1514			VW	1514	
AC5970	AUDI	80, 86, 88, 90, 91		AC5970	AUDI	80, 86, 88, 90, 91	
	SKODA	1198			SKODA	1198	
	VW	1514			VW	1514	
AD890	AUSTIN	104		AD950	MG	732	
AD950	MG	732			MORRIS	774	
AD5020	FORD	428, 444		AD5020	FORD	428, 444	
AD5030	MITSUBISHI	740		AD5030	MITSUBISHI	740	
	RENAULT	1030, 1044, 1088			RENAULT	1030, 1044, 1088	
AD5040	MITSUBISHI	740		AD5050	MITSUBISHI	740	
	RENAULT	1030, 1044, 1088			RENAULT	1030, 1044, 1088	
AD5050	MITSUBISHI	740		AD5100	CITROËN	264, 274, 282	
	RENAULT	1030, 1044, 1088			PEUGEOT	942, 956	
AD5100	CITROËN	264, 274, 282		AD5130	CITROËN	216, 224, 228, 232, 234, 270, 272	
	PEUGEOT	942, 956			FORD	430, 432, 438, 440	
AD5130	CITROËN	216, 224, 228, 232, 234, 270, 272			MAZDA	634	
	FORD	430, 432, 438, 440			MINI	736	
	MAZDA	634			PEUGEOT	928, 934, 936, 938, 946, 960, 974, 976	
	MINI	736		AD5140	CITROËN	216, 224, 228, 232, 234, 270, 272	
	PEUGEOT	928, 934, 936, 938, 946, 960, 974, 976			FORD	430, 432, 438, 440	
AD5140	CITROËN	216, 224, 228, 232, 234, 270, 272			MAZDA	634	
	FORD	430, 432, 438, 440			MINI	736	
	MAZDA	634			PEUGEOT	928, 934, 936, 938, 946, 960, 974, 976	
	MINI	736		AD5150	CITROËN	216, 224, 228, 232, 234, 270, 272	
	PEUGEOT	928, 934, 936, 938, 946, 960, 974, 976			FORD	438, 442, 468	
AD5150	CITROËN	216, 224, 228, 232, 234, 270, 272			LANCIA	596	
	FORD	438, 442, 468			PEUGEOT	948, 958, 960, 962, 970, 972, 974, 982	
	LANCIA	596		AD5500	CITROËN	234, 236, 238, 252	
	PEUGEOT	948, 958, 960, 962, 970, 972, 974, 982			FIAT	380, 398, 400	
AD5150	CITROËN	216, 224, 228, 232, 234, 270, 272			FORD	438, 442, 468	
	FORD	438, 442, 468			LANCIA	596	
	LANCIA	596			PEUGEOT	948, 958, 960, 962, 970, 972, 974, 982	
	PEUGEOT	948, 958, 960, 962, 970, 972, 974, 982					

NUMERICAL PARTS LIST









Numerische Teilenummernliste • Liste des références produits
Lista de referencias









							
AD5510	CITROËN 234, 236, 238, 252 FIAT 380, 398, 400 FORD 438, 442, 468 LANCIA 596 PEUGEOT 948, 958, 960, 962, 970, 972, 974, 982	AD5820	FIAT 332, 352, 366, 368 LANCIA 594, 604 OPEL 828, 832, 846, 852, 882 SUZUKI 1224, 1228, 1232 VAUXHALL 1322, 1352, 1372	AE5140	VOLVO 1422, 1438, 1440	AE5760	CHRYSLER 184 MERCEDES-BENZ 674, 678, 686, 688, 694, 698, 700, 702, 704, 706, 708, 720, 722
AD5520	CITROËN 234, 236, 238, 252 FIAT 380, 398, 400 FORD 438, 442, 468 LANCIA 596 PEUGEOT 948, 958, 960, 962, 970, 972, 974, 982	AD5830	FIAT 318, 320, 352, 358, 366, 368, 382 LANCIA 602, 604	AE5150	VOLVO 1424, 1440	AE5880	NISSAN 800
AD5600	LAND ROVER 612, 616	AD5840	ALFA ROMEO 18, 22, 38 FIAT 324, 384 OPEL 840, 880, 888, 896 SAAB 1130, 1132 VAUXHALL 1332, 1370, 1374, 1378	AE5160	VOLVO 1424	AE5890	NISSAN 800
AD5610	LAND ROVER 612, 616	AD5850	ALFA ROMEO 18, 22, 38 FIAT 324, 384 OPEL 840, 880, 888, 896 SAAB 1130, 1132 VAUXHALL 1332, 1370, 1374, 1378	AE5200	DACIA 286 NISSAN 782, 794, 798, 800, 810 RENAULT 1026, 1028, 1040, 1042, 1054, 1082, 1084, 1086	AE5910	INFINITI 516 NISSAN 782, 796, 800 RENAULT 1034, 1092
AD5630	SEAT 1144, 1146, 1156 VW 1494, 1516	AD5860	ALFA ROMEO 18, 22, 38 FIAT 324, 384 OPEL 840, 880, 888, 896 SAAB 1130, 1132 VAUXHALL 1332, 1370, 1374, 1378	AE5210	NISSAN 794, 806 OPEL 872 RENAULT 1024, 1034, 1048, 1050, 1092 VAUXHALL 1360	AE5920	OPEL 834, 848, 868 VAUXHALL 1324, 1336, 1350, 1358
AD5640	SEAT 1144, 1146, 1158, 1168 VW 1454, 1496, 1520	AD5870	ALFA ROMEO 24, 38, 40, 42	AE5220	OPEL 872, 894 RENAULT 1050, 1090 VAUXHALL 1360, 1362, 1378	AE5930	OPEL 834, 868, 894 VAUXHALL 1324, 1358, 1378
AD5650	AUDI 66 SEAT 1144, 1148, 1158 SKODA 1186, 1196 VW 1464, 1496, 1522	AD5880	ALFA ROMEO 24, 30 LANCIA 600	AE5240	FIAT 332, 350, 358, 360, 364, 368, 382, 386 LANCIA 600, 604	AE5950	OPEL 828, 848 VAUXHALL 1320, 1352
AD5660	AUDI 66 SEAT 1144, 1148, 1158 SKODA 1186, 1196 VW 1464, 1496, 1522	AD5890	NISSAN 794	AE5260	VOLVO 1414, 1422, 1434, 1438, 1440	AF070	AUSTIN 104, 106, 108 MG 732 MORRIS 774
AD5670	AUDI 66 SEAT 1144, 1148, 1158 SKODA 1186, 1196 VW 1464, 1496, 1522	AD5900	NISSAN 806	AE5270	VOLVO 1414, 1422, 1434, 1438, 1440	AF240	ALFA ROMEO 38, 40
AD5690	CHEVROLET 178, 180 DAEWOO 294, 298	AD5910	ALFA ROMEO 24, 30 LANCIA 600	AE5280	VOLVO 1414, 1422, 1434, 1438, 1440	AF370	ALFA ROMEO 38
AD5700	CITROËN 212, 214, 216, 218, 220, 226, 228, 230, 254, 258, 270, 278, 280 PEUGEOT 924, 926, 928, 930, 934, 940, 946, 948, 952, 974, 976, 986	AD5920	ALFA ROMEO 24, 30 LANCIA 600	AE5290	VOLVO 1414, 1422, 1434, 1438, 1440	AF460	AUSTIN 104, 108 MG 732
AD5710	CITROËN 212, 214, 216, 218, 220, 226, 228, 230, 254, 258, 270, 278, 280 PEUGEOT 924, 926, 928, 930, 934, 940, 946, 948, 952, 974, 976, 986	AD5930	ALFA ROMEO 24, 30 LANCIA 600	AE5300	VOLVO 1414, 1422, 1434, 1438, 1440	AF470	AUSTIN 104, 106, 108 MG 726, 732 ROVER 1116, 1118
AD5720	JEEP 566 MERCEDES-BENZ 674, 678, 688, 696, 700, 712	AD5940	ALFA ROMEO 18, 24, 28, 40, 42	AE5320	FORD 412, 440, 444, 448 MAZDA 656	AF880	FORD 412, 418 LOTUS 630
AD5760	JEEP 568	AD5950	ALFA ROMEO 18, 24, 28, 40, 42	AE5330	DAEWOO 292, 294 MERCEDES-BENZ 674, 676, 688, 690, 692, 694, 698, 702, 704, 706 SSANGYONG 1204, 1206	AF5030	LEXUS 618 TOYOTA 1264, 1294, 1302
AD5800	FIAT 332, 352, 366, 368 LANCIA 594, 604 OPEL 828, 832, 846, 852, 882 SUZUKI 1224, 1228, 1232 VAUXHALL 1322, 1352, 1372	AD5960	LANCIA 600	AE5340	BMW 164	AF5031	LEXUS 618 TOYOTA 1264, 1294, 1302
AD5810	FIAT 332, 352, 366, 368 LANCIA 594, 604 OPEL 828, 832, 846, 852, 882 SUZUKI 1224, 1228, 1232 VAUXHALL 1322, 1352, 1372	AD5970	FIAT 322, 332, 354, 356, 360, 382 LANCIA 592	AE5350	BMW 164	AF5060	HYUNDAI 510, 512
		AD5980	NISSAN 794 RENAULT 1026, 1027, 1042, 1058, 1090	AE5360	BMW 164	AF5070	HYUNDAI 510, 512
		AD5990	NISSAN 806 OPEL 894 RENAULT 1024, 1030, 1032, 1042, 1044, 1046, 1048, 1056, 1058, 1084, 1086, 1090 VAUXHALL 1378	AE5370	BMW 164	AF5190	BMW 134, 136, 140, 142, 148, 150, 156, 168, 172, 174
		AE330	TRIUMPH 1312	AE5380	BMW 164	AF5310	AUDI 64, 88 VOLVO 1398, 1418, 1422, 1436 VW 1492, 1544
		AE540	JAGUAR 552	AE5390	BMW 164	AF5320	AUDI 64, 88 VOLVO 1398, 1418, 1422, 1436 VW 1492, 1544
		AE600	ZASTAVA 1554	AE5400	OPEL 838, 848, 856, 870 VAUXHALL 1328, 1336, 1352, 1356, 1360	AF5330	AUDI 64, 88 VOLVO 1398, 1418, 1422, 1436 VW 1492, 1544
		AE780	MORRIS 774	AE5410	OPEL 838, 848, 856, 870 VAUXHALL 1328, 1336, 1352, 1356, 1360	AF5340	AUDI 64 VW 1542, 1544
		AE5010	CITROËN 258 PEUGEOT 926	AE5420	FIAT 332, 358, 360, 368, 382, 386 LANCIA 600, 604	AF5350	AUDI 64 VW 1542, 1544
		AE5020	CITROËN 258 PEUGEOT 926	AE5430	VOLVO 1414, 1436, 1440	AF5360	AUDI 64 VW 1542, 1544
		AE5030	CITROËN 258 PEUGEOT 926	AE5440	MITSUBISHI 768	AF5381	AUDI 68, 76, 82 FORD 442 SEAT 1140, 1142, 1154, 1164, 1166, 1172, 1178, 1180 SKODA 1186, 1192, 1196 VW 1452, 1458, 1460, 1480, 1482, 1490, 1496, 1498, 1510, 1530, 1534, 1536, 1538, 1542
		AE5040	VOLVO 1388, 1390	AE5450	MERCEDES-BENZ 672, 686		
		AE5050	CITROËN 248, 256 PEUGEOT 978	AE5460	MERCEDES-BENZ 672, 686 CHRYSLER 184		
		AE5060	SAAB 1130, 1132	AE5470	MERCEDES-BENZ 674, 678, 686, 688, 694, 698, 700, 702, 704, 706, 708, 720, 722		
		AE5110	RENAULT 1024, 1032, 1042, 1048, 1058, 1086, 1092				

							
AF5391	AUDI 68, 76, 82	AG910	LAND ROVER 610, 612, 616	AG6130	INFINITI 516	AG7720	ISUZU 528
	FORD 442		MG 732		NISSAN 782, 796, 800		OPEL 846, 870
	SEAT 1140, 1142, 1154, 1164, 1166, 1172, 1178, 1180		ROVER 1120	AG6150	RENAULT 1034, 1092	AG7730	ISUZU 528
	SKODA 1186, 1192, 1196	AG5000	TRIUMPH 1314		SUBARU 1210, 1214		OPEL 846, 870
	VW 1452, 1458, 1460, 1480, 1482, 1490, 1496, 1498, 1510, 1530, 1534, 1536, 1538, 1542		FORD 444	AG6220	FIAT 352, 366, 382	AG7740	MITSUBISHI 764, 766
AF5401	AUDI 68, 76, 82		SEAT 1142, 1174, 1182		LANCIA 594, 604	AG7750	MITSUBISHI 764, 766
	FORD 442	AG5070	VW 1454, 1484, 1538, 1544	AG7300	IVECO 544	AG7760	MITSUBISHI 764, 766
	SEAT 1140, 1142, 1154, 1164, 1166, 1172, 1178, 1180	AG5080	HYUNDAI 504, 508	AG7310	FIAT 352, 382	AG7780	KIA 576
	SKODA 1186, 1192, 1196		ISUZU 528		LANCIA 594, 604	AG7790	KIA 576
	VW 1452, 1458, 1460, 1480, 1482, 1490, 1496, 1498, 1510, 1530, 1534, 1536, 1538, 1542		OPEL 870	AG7380	FIAT 332, 352	AG7800	SEAT 1182
AF5430	HYUNDAI 510, 512	AG5090	VAUXHALL 1360		LANCIA 594, 604		VW 1452, 1484, 1514
	KIA 574		OPEL 870	AG7390	ALFA ROMEO 16, 22, 26	AG7810	FORD 446, 450
AF5470	MITSUBISHI 756	AG5100	VAUXHALL 1360		FIAT 320, 322, 328, 332, 334, 352, 354, 358, 370, 384, 386		NISSAN 782
AF5480	MITSUBISHI 756, 768	AG5110	LEXUS 618		LANCIA 594	AG7820	FORD 446, 450
AF5490	MITSUBISHI 764, 766	AG5110	MAZDA 650, 652	AG7400	ALFA ROMEO 26		NISSAN 782
AF5500	MITSUBISHI 750	AG5120	MAZDA 640		FIAT 328, 352, 384	AG7830	KIA 574
AF5540	NISSAN 808, 810, 822	AG5130	KIA 574, 576	AG7410	ALFA ROMEO 26	AG7840	KIA 574, 576
AF5600	NISSAN 802		MAZDA 644, 646		FIAT 328, 352, 384	AG7850	MAZDA 652
AF5690	INFINITI 516	AG5140	SUZUKI 1222, 1230	AG7420	ALFA ROMEO 26	AG7860	HONDA 496
	NISSAN 800	AG5150	MITSUBISHI 748, 758, 760, 768, 770		FIAT 330	AG7870	HONDA 496
AF5700	INFINITI 516	AG5160	MITSUBISHI 766	AG7430	ALFA ROMEO 26	AG7880	NISSAN 792, 798
AF5710	INFINITI 516	AG5170	NISSAN 812, 822		FIAT 330	AG7890	HONDA 482
AF5720	INFINITI 516	AG5180	NISSAN 812, 822	AG7440	ALFA ROMEO 26	AG7900	HONDA 488
	NISSAN 796	AG5190	NISSAN 784, 812		FIAT 330	AG7910	HYUNDAI 502
AF5730	INFINITI 516	AG5200	SUBARU 1216	AG7480	ALFA ROMEO 26	AG7920	HYUNDAI 504
	NISSAN 796	AG5210	SUBARU 1210, 1212		FIAT 352, 384		KIA 572, 576
AF5740	NISSAN 802, 818	AG5230	TOYOTA 1248, 1290	AG7490	TOYOTA 1250, 1274, 1276, 1298, 1300, 1306	AG7930	HYUNDAI 504, 510, 512
AF5750	NISSAN 802, 818	AG5240	TOYOTA 1250, 1276, 1298		TOYOTA 1250, 1274, 1276, 1298, 1300, 1306		KIA 572, 576
AF5760	SUBARU 1216	AG5250	NISSAN 812, 822	AG7500	TOYOTA 1250, 1274, 1276, 1298, 1300, 1306	AG7940	HYUNDAI 504, 510, 512
AF5780	TOYOTA 1250, 1252, 1254, 1300	AG5260	SUZUKI 1220, 1222, 1228, 1232		TOYOTA 1250, 1274, 1276, 1298, 1300, 1306		KIA 572, 576
AF5790	TOYOTA 1292	AG5270	RENAULT 1034, 1078	AG7510	TOYOTA 1250, 1274, 1276, 1298, 1300, 1306	AG7950	RENAULT 1026, 1042
AF5800	TOYOTA 1292	AG5280	SUBARU 1210, 1212		TOYOTA 1290	AG7960	HONDA 494
AF5810	TOYOTA 1292	AG5290	SUBARU 1212	AG7520	TOYOTA 1290	AG7970	DAIHATSU 304, 306
AF5820	TOYOTA 1292	AG5300	MITSUBISHI 748, 758, 760, 768, 770	AG7530	TOYOTA 1290	AG7980	SUBARU 1216
AF5840	TOYOTA 1252, 1254, 1298, 1300		PROTON 990	AG7540	TOYOTA 1290	AG7990	DAEWOO 290
AF5850	TOYOTA 1304	AG5301	MITSUBISHI 748, 758, 760, 768, 770	AG7550	TOYOTA 1290	AG8000	CHEVROLET 178
AF5860	TOYOTA 1292		PROTON 990	AG7560	TOYOTA 1290		DAEWOO 290, 292, 296
AF5870	TOYOTA 1292	AG5302	MITSUBISHI 740, 748, 758, 760, 768, 770	AG7570	TOYOTA 1304	AG8010	HONDA 498
AF5880	TOYOTA 1284, 1286		RENAULT 1048, 1058	AG7580	TOYOTA 1304	AG8020	SUZUKI 1220, 1222, 1228, 1230
AF5890	TOYOTA 1284, 1286	AG5420	SUBARU 1210, 1212	AG7590	TOYOTA 1304	AG8030	HYUNDAI 504, 508
AF5910	TOYOTA 1284, 1286	AG5580	SUBARU 1210, 1212	AG7600	MINI 736	AG8050	HYUNDAI 502
AF5920	TOYOTA 1284, 1286	AG5590	SUBARU 1210, 1212		TOYOTA 1266, 1282, 1304, 1308, 1310	AG8060	HYUNDAI 502, 506
AF5930	TOYOTA 1284, 1286	AG5600	SUBARU 1214, 1216	AG7610	MINI 736	AG8080	MITSUBISHI 754, 766, 768
AF5940	TOYOTA 1284, 1286	AG5610	SUBARU 1214, 1216		TOYOTA 1266, 1282, 1304, 1308, 1310	AG8090	HYUNDAI 514
AF5950	SEAT 1146, 1156	AG5690	HYUNDAI 510, 512	AG7620	MINI 736	AG8100	SUZUKI 1224
	SKODA 1186, 1194	AG5710	SUZUKI 1230		TOYOTA 1266, 1282, 1304, 1308, 1310	AG8110	SUZUKI 1224
	VW 1518	AG5720	SUZUKI 1230	AG7630	LEXUS 618	AG8120	SUZUKI 1230
AG210	CARBODIES 176	AG5730	SUZUKI 1222, 1230	AG7640	LEXUS 618	AG8130	HONDA 490, 494
	LAND ROVER 610	AG5740	SUZUKI 1222, 1230	AG7650	TOYOTA 1260, 1274	AG8140	KIA 572
AG900	TRIUMPH 1312, 1314	AG5760	HONDA 480, 496	AG7660	TOYOTA 1260, 1274	AG8150	MAZDA 658
		AG5780	HONDA 480, 498	AG7670	TOYOTA 1250, 1298	AG8160	MAZDA 658
		AG5810	HONDA 490, 498	AG7680	MITSUBISHI 760	AG8170	MAZDA 634
		AG5920	DAIHATSU 302, 304, 306, 308, 310	AG7690	MITSUBISHI 742, 754, 768	AG8180	SUZUKI 1222, 1224, 1226, 1232
		AG6040	HYUNDAI 502	AG7700	MITSUBISHI 762	AG8190	MAZDA 636, 644, 646, 656
		AG6050	IVECO 544	AG7710	MITSUBISHI 740	AG8200	KIA 572, 576
		AG6060	IVECO 544			AG8210	NISSAN 796
		AG6120	MITSUBISHI 764			AG8220	NISSAN 796
						AG8230	NISSAN 796
						AG8240	NISSAN 796

NUMERICAL PARTS LIST









Numerische Teilenummernliste • Liste des références produits
Lista de referencias









													
AG8250	KIA	574	AG8960	AUDI	72, 78, 84	AG9590	CHEVROLET	180	AG9800	OPEL	882, 892		
AG8260	KIA	572, 576		AG8960	MITSUBISHI	750, 762		OPEL	880, 892, 896	RENAULT	1034, 1092		
AG8290	HYUNDAI	502, 504, 506, 508, 512		AG8960	SEAT	1142, 1174, 1180		VAUXHALL	1370, 1376, 1380	SAAB	1134		
AG8310	FORD	426, 436		AG8960	SKODA	1194	AG9600	AUDI	70, 78	VAUXHALL	1370, 1376		
	MAZDA	634		AG8960	VW	1482, 1484, 1492, 1514, 1540		SEAT	1142, 1174, 1180	AG9810	OPEL	882, 892	
AG8320	FORD	440, 450, 468		AG8970	AUDI	72, 78, 84		SKODA	1194	AG9810	RENAULT	1034, 1092	
	VOLVO	1402, 1406, 1412, 1430		AG8970	MITSUBISHI	750, 762		VW	1462, 1484, 1490, 1512, 1514, 1538	AG9810	SAAB	1134	
AG8340	VOLVO	1404, 1412, 1428		AG8970	SEAT	1142, 1174, 1180		AG9610	AUDI	72, 100	AG9820	OPEL	882, 892
AG8370	MERCEDES-BENZ	676, 678, 680, 694, 700, 708		AG8970	SKODA	1194		VW	1462, 1486, 1498, 1516, 1538, 1546	AG9820	RENAULT	1034, 1092	
AG8380	MERCEDES-BENZ	676, 678, 680, 694, 700, 708		AG8970	VW	1482, 1484, 1492, 1514, 1540		AG9630	AUDI	70, 78	AG9820	SAAB	1134
AG8390	MERCEDES-BENZ	672, 674		AG8990	SMART	1200		AG9630	SEAT	1142, 1172, 1180	AG9820	VAUXHALL	1370, 1376
AG8400	MERCEDES-BENZ	672, 674		AG9000	BMW	142, 152, 156, 162, 168, 170		AG9630	SKODA	1194, 1196	AG9830	DAIHATSU	302, 304, 306, 308, 310
AG8410	MERCEDES-BENZ	676, 678, 680, 694, 700, 704, 708		AG9010	BMW	142, 152, 156, 162, 168, 170		AG9630	VW	1460, 1462, 1482, 1490, 1514, 1536, 1540	AG9840	HONDA	490
AG8420	MERCEDES-BENZ	676, 678, 680, 694, 700, 704, 708		AG9020	BMW	142, 152, 156, 162, 168, 170		AG9640	AUDI	70, 78	AG9850	HONDA	490
AG8430	MERCEDES-BENZ	678, 698, 700, 704, 706		AG9020	BMW	142, 152, 156, 162, 168, 170		AG9640	SEAT	1142, 1172, 1180	AG9860	HONDA	490
AG8440	MERCEDES-BENZ	678, 698, 700, 704, 706		AG9030	CITROËN	228, 230, 232		AG9640	SKODA	1194, 1196	AG9870	KIA	576
AG8470	MERCEDES-BENZ	698, 704		AG9030	PEUGEOT	934, 936, 946, 974		AG9640	VW	1460, 1462, 1482, 1490, 1514, 1536, 1540	AG9880	KIA	576
AG8480	MERCEDES-BENZ	698, 704		AG9080	MAZDA	636, 640, 650		AG9650	AUDI	70, 78	AG9890	KIA	576
AG8490	MERCEDES-BENZ	694, 702		AG9090	TOYOTA	1254		AG9650	SEAT	1142, 1172, 1180	AG9900	KIA	574
AG8500	MERCEDES-BENZ	666		AG9100	TOYOTA	1254		AG9650	SKODA	1194, 1196	AG9910	KIA	572
AG8501	MERCEDES-BENZ	666, 668		AG9110	TOYOTA	1260, 1270, 1272		AG9650	VW	1460, 1462, 1482, 1490, 1514, 1536, 1540	AG9920	MITSUBISHI	742, 758
AG8790	MERCEDES-BENZ	668, 676, 680, 708		AG9120	MITSUBISHI	768, 770		AG9660	CHRYSLER	190	AG9930	NISSAN	822
AG8800	AUDI	72, 78, 84		AG9130	MITSUBISHI	746, 750, 762, 770		AG9670	CHRYSLER	190	AG9940	NISSAN	822
	MITSUBISHI	750, 762		AG9140	TOYOTA	1262		AG9680	CHRYSLER	190	AG9950	NISSAN	822
	SEAT	1142, 1174, 1180		AG9150	MITSUBISHI	750		AG9690	JEEP	568	AG9960	NISSAN	822
	SKODA	1194		AG9170	HONDA	482		AG9710	CITROËN	268, 270	AG9970	NISSAN	822
	VW	1482, 1484, 1492, 1514, 1540		AG9180	HONDA	482, 494		AG9710	PEUGEOT	960, 968	AG9980	NISSAN	822
AG8810	AUDI	78, 84		AG9190	KIA	572		AG9710	RENAULT	1034, 1048, 1082	AG9990	LEXUS	618
	VW	1512		AG9270	LEXUS	618		AG9720	CITROËN	268, 270		TOYOTA	1248, 1264, 1278, 1294
AG8820	VW	1498, 1544		AG9280	LEXUS	618		AG9720	PEUGEOT	960, 968	AH850	FORD	412, 418, 444, 468
AG8830	VW	1460, 1484		AG9290	BMW	120, 138, 142, 152, 160, 162, 168, 174		AG9720	RENAULT	1034, 1048, 1082	AH860	FORD	412, 426, 444, 456, 458, 464, 466, 468, 470
AG8840	SKODA	1186		AG9310	CITROËN	224		AG9730	PEUGEOT	960, 968	AH5000	MERCEDES-BENZ	666, 668
	VW	1462, 1518		AG9310	DAIHATSU	304, 308		AG9730	RENAULT	1034, 1048, 1082	AH5010	MERCEDES-BENZ	674, 678, 680, 690, 696, 698, 700, 702
AG8850	AUDI	68		AG9310	PEUGEOT	928		AG9740	CITROËN	268, 270	AH5020	MERCEDES-BENZ	674, 678, 680, 690, 696, 698, 700, 702
	SEAT	1150, 1160		AG9310	TOYOTA	1252, 1296, 1308, 1310		AG9740	PEUGEOT	960, 968	AH5030	OPEL	828, 832, 848, 850, 852, 854, 868, 882
	SKODA	1186, 1190, 1196		AG9320	RENAULT	1024, 1046, 1086, 1088		AG9750	RENAULT	1034, 1048, 1082		VAUXHALL	1320, 1322, 1350, 1352, 1354, 1356, 1358, 1372
	VW	1462, 1466, 1488, 1504, 1522, 1524, 1538		AG9490	DACIA	286		AG9750	CITROËN	238	AH5040	CITROËN	236, 238
AG8860	AUDI	80, 88, 90, 98		AG9490	NISSAN	782, 794, 798, 800		AG9750	PEUGEOT	960, 962, 970, 974		FIAT	400
	VW	1516, 1538		AG9490	RENAULT	1026, 1028, 1040, 1042, 1043, 1044, 1050, 1054, 1055, 1060, 1082, 1084, 1086, 1092		AG9760	RENAULT	1042, 1058, 1084, 1088		PEUGEOT	960, 962, 970, 974
AG8870	AUDI	80, 88, 90, 98		AG9540	BMW	134, 144, 168, 172		AG9770	OPEL	882, 892	AH5050	CITROËN	236, 238
	VW	1516, 1538		AG9550	BMW	134, 144, 168, 172		AG9770	RENAULT	1034, 1092		FIAT	400
AG8880	AUDI	80, 88, 90, 98		AG9560	FORD	432, 436, 440		AG9770	SAAB	1134		PEUGEOT	960, 962, 970, 974
	VW	1516, 1538		AG9560	MAZDA	634, 652		AG9780	VAUXHALL	1370, 1376		RENAULT	1024, 1030, 1050, 1088
AG8890	AUDI	80, 88, 90, 98		AG9560	VOLVO	1402, 1406, 1428		AG9780	OPEL	882, 892	AH5060	CITROËN	236, 238
	VW	1516, 1538		AG9570	OPEL	842, 882, 896		AG9780	RENAULT	1034, 1092		FIAT	400
AG8900	AUDI	80, 88, 90, 98		AG9570	VAUXHALL	1332, 1334, 1378, 1380		AG9780	SAAB	1134		PEUGEOT	960, 962, 970, 974
	VW	1516, 1538		AG9580	ALFA ROMEO	26, 36, 44		AG9790	VAUXHALL	1370, 1376		RENAULT	1024, 1030, 1050, 1088
AG8910	AUDI	80, 88, 90, 98		AG9580	CHEVROLET	178, 180		AG9790	OPEL	882, 892	AH5070	CITROËN	236, 238
	VW	1516, 1538		AG9580	FIAT	330		AG9790	RENAULT	1034, 1092		FIAT	400
AG8920	VW	1498, 1544		AG9580	PEUGEOT	928		AG9790	SAAB	1134		PEUGEOT	960, 962, 970, 974
AG8930	VW	1498, 1544		AG9580	OPEL	844, 882, 890, 896		AG9790	VAUXHALL	1370, 1376		RENAULT	1024, 1030, 1050, 1088
AG8940	VW	1460, 1484		AG9580	VAUXHALL	1334, 1376, 1378, 1380					AH5080	CITROËN	248, 256
AG8950	VW	1460, 1484										PEUGEOT	978

							
AH5090	CITROËN 248, 256 PEUGEOT 978	AY210	OPEL 834, 848, 854, 884 VAUXHALL 1322, 1324, 1354, 1372	AY460	CITROËN 240, 250 FIAT 350, 366, 368, 376, 388, 390, 392 LANCIA 584, 588 PEUGEOT 978	AY700	CITROËN 248 FIAT 344, 346 IVECO 536, 538 PEUGEOT 978
AH5100	CITROËN 248, 256 PEUGEOT 978	AY220	OPEL 836, 856, 884, 886, 894 VAUXHALL 1326, 1328, 1354, 1372, 1378	AY470	FIAT 318, 322, 354, 358, 360 LANCIA 584, 588, 592	AY710	OPEL 828 RENAULT 1056, 1072 VAUXHALL 1320 VOLVO 1390, 1392, 1410, 1428
AH5110	CITROËN 248, 256 PEUGEOT 978	AY260	VOLVO 1402, 1424, 1438	AY480	FIAT 318, 322, 352 LANCIA 602	AY720	OPEL 828 RENAULT 1056, 1072 VAUXHALL 1320 VOLVO 1390, 1392, 1410, 1428
AH5120	BMW 120, 144, 170	AY270	BMW 128	AY490	ALFA ROMEO 14, 16, 20, 22, 28, 40, 42	AY730	OPEL 828 RENAULT 1056, 1072 VAUXHALL 1320 VOLVO 1390, 1392, 1410, 1428
AJ050	NISSAN 780, 786	AY280	BMW 128	AY500	ALFA ROMEO 12, 14, 18, 20, 22, 38, 40, 42	AY800	TOYOTA 1288
AJ120	MAZDA 648, 650	AY290	ALFA ROMEO 34, 36 FIAT 330, 340, 342 IVECO 536, 538, 546 LANCIA 598, 600 OPEL 828, 872 RENAULT 1052, 1082, 1090 VAUXHALL 1320, 1362	AY510	ALFA ROMEO 12, 14	AY840	ISUZU 524, 526, 528 OPEL 854, 862 VAUXHALL 1324, 1338, 1354, 1364, 1366
AJ230	MAZDA 654	AY300	ALFA ROMEO 34, 36 FIAT 330, 340, 342 IVECO 536, 538, 546 LANCIA 598, 600 OPEL 828, 872 RENAULT 1052, 1082, 1090 VAUXHALL 1320, 1362	AY520	ALFA ROMEO 14, 16, 22 FIAT 320, 322, 354, 358 LANCIA 592 SAAB 1130	AY850	ISUZU 524, 526, 528 OPEL 854, 862 VAUXHALL 1324, 1338, 1354, 1364, 1366
AJ290	TOYOTA 1286	AY310	ALFA ROMEO 34, 36 FIAT 330, 340, 342 IVECO 536, 538, 546 LANCIA 598, 600 OPEL 828, 872 RENAULT 1052, 1082, 1090 VAUXHALL 1320, 1362	AY530	ALFA ROMEO 14, 16, 22 FIAT 320, 322, 354, 358 LANCIA 592 SAAB 1130	AY860	ISUZU 524, 526, 528 OPEL 854, 862 VAUXHALL 1324, 1338, 1354, 1364, 1366
AJ490	NISSAN 780, 802	AY320	FIAT 326 LANCIA 590	AY540	ALFA ROMEO 14, 16, 22 FIAT 320, 322, 354, 358 LANCIA 592 SAAB 1130	AY900	ISUZU 524, 526, 528 OPEL 854, 862 VAUXHALL 1324, 1338, 1354, 1364, 1366
AJ580	NISSAN 780, 788, 794, 796	AY400	ALFA ROMEO 10, 12, 20, 28, 34, 38 CHRYSLER 184, 190 FORD 460 JEEP 562, 564, 566 OPEL 858 ROVER 1116, 1120 VAUXHALL 1358	AY550	ALFA ROMEO 24, 30 FIAT 356 LANCIA 590, 594	AY910	ISUZU 524, 526, 528 OPEL 854, 862 VAUXHALL 1324, 1338, 1354, 1364, 1366
AJ630	MAZDA 638, 650, 652, 656	AY410	ALFA ROMEO 10, 12, 20, 28, 34, 38 CHRYSLER 184, 190 FORD 460 JEEP 562, 564, 566 OPEL 858 ROVER 1116, 1120 VAUXHALL 1358	AY560	ALFA ROMEO 24, 30 FIAT 356 LANCIA 590, 594	AY920	ISUZU 524, 526, 528 OPEL 854, 862 VAUXHALL 1324, 1338, 1354, 1364, 1366
AJ650	MAZDA 638	AY420	ALFA ROMEO 10, 12, 20, 28, 34, 38 CHRYSLER 184, 190 FORD 460 JEEP 562, 564, 566 OPEL 858 ROVER 1116, 1120 VAUXHALL 1358	AY570	ALFA ROMEO 24, 30 FIAT 356 LANCIA 590, 594	AY930	VW 1520
AJ690	MAZDA 638	AY430	FIAT 326, 362, 380	AY580	FIAT 342, 344 IVECO 534, 536, 538, 540, 542, 544, 546, 548 RENAULT 1052	AY940	AUDI 72 SEAT 1150, 1162, 1176 VW 1468, 1470, 1502, 1524, 1546
AJ910	DAIHATSU 310	AY440	ALFA ROMEO 10, 12, 20, 28, 34, 38 CHRYSLER 184, 190 FORD 460 JEEP 562, 564, 566 OPEL 858 ROVER 1116, 1120 VAUXHALL 1358	AY590	FIAT 342, 344 IVECO 534, 536, 538, 540, 542, 544, 546, 548 RENAULT 1052	AY960	AUDI 54, 56, 62, 64, 86, 96, 98
AJ960	TOYOTA 1262, 1278	AY450	FIAT 350, 382, 388, 392, 404 LANCIA 586 ZASTAVA 1554	AY610	ALFA ROMEO 28	AY970	AUDI 68, 72, 74, 76, 82, 90, 100 SEAT 1140, 1152, 1164, 1172, 1176 SKODA 1190, 1196 VW 1448, 1474, 1476, 1498, 1506, 1508, 1528, 1534
AK260	MG 732 TRIUMPH 1312	AY460	ALFA ROMEO 10, 12, 20, 28, 34, 38 CHRYSLER 184, 190 FORD 460 JEEP 562, 564, 566 OPEL 858 ROVER 1116, 1120 VAUXHALL 1358	AY620	ALFA ROMEO 24, 30	AY980	AUDI 66 SEAT 1150, 1160, 1170, 1176 VW 1448, 1466, 1524
AK280	TRIUMPH 1312	AY470	ALFA ROMEO 10, 12, 20, 28, 34, 38 CHRYSLER 184, 190 FORD 460 JEEP 562, 564, 566 OPEL 858 ROVER 1116, 1120 VAUXHALL 1358	AY630	ALFA ROMEO 24, 30	BB610	TRIUMPH 1314
AK300	BEDFORD 112 VAUXHALL 1378	AY480	ALFA ROMEO 10, 12, 20, 28, 34, 38 CHRYSLER 184, 190 FORD 460 JEEP 562, 564, 566 OPEL 858 ROVER 1116, 1120 VAUXHALL 1358	AY640	ALFA ROMEO 18, 24, 30, 38, 40, 44 LANCIA 600	BC240	FORD 414, 426, 450
AK520	TRIUMPH 1312	AY490	ALFA ROMEO 10, 12, 20, 28, 34, 38 CHRYSLER 184, 190 FORD 460 JEEP 562, 564, 566 OPEL 858 ROVER 1116, 1120 VAUXHALL 1358	AY660	IVECO 534	BC260	TOYOTA 1290
AK660	LEYLAND / LDV 626 MG 732 MORRIS 774	AY500	ALFA ROMEO 10, 12, 20, 28, 34, 38 CHRYSLER 184, 190 FORD 460 JEEP 562, 564, 566 OPEL 858 ROVER 1116, 1120 VAUXHALL 1358	AY680	CITROËN 248 FIAT 344, 346 IVECO 536, 538 PEUGEOT 978		
AN110	IVECO 534	AY510	ALFA ROMEO 10, 12, 20, 28, 34, 38 CHRYSLER 184, 190 FORD 460 JEEP 562, 564, 566 OPEL 858 ROVER 1116, 1120 VAUXHALL 1358	AY690	CITROËN 248 FIAT 344, 346 IVECO 536, 538 PEUGEOT 978		
AN300	ALFA ROMEO 8, 10, 30, 32, 36, 40, 42	AY520	ALFA ROMEO 10, 12, 20, 28, 34, 38 CHRYSLER 184, 190 FORD 460 JEEP 562, 564, 566 OPEL 858 ROVER 1116, 1120 VAUXHALL 1358				
AN350	ALFA ROMEO 6, 12, 30, 32, 36 NISSAN 790	AY530	ALFA ROMEO 10, 12, 20, 28, 34, 38 CHRYSLER 184, 190 FORD 460 JEEP 562, 564, 566 OPEL 858 ROVER 1116, 1120 VAUXHALL 1358				
AN370	ALFA ROMEO 32, 38, 40, 42	AY540	ALFA ROMEO 10, 12, 20, 28, 34, 38 CHRYSLER 184, 190 FORD 460 JEEP 562, 564, 566 OPEL 858 ROVER 1116, 1120 VAUXHALL 1358				
AN450	IVECO 534	AY550	ALFA ROMEO 10, 12, 20, 28, 34, 38 CHRYSLER 184, 190 FORD 460 JEEP 562, 564, 566 OPEL 858 ROVER 1116, 1120 VAUXHALL 1358				
AX180	ISUZU 520, 522, 526	AY560	ALFA ROMEO 10, 12, 20, 28, 34, 38 CHRYSLER 184, 190 FORD 460 JEEP 562, 564, 566 OPEL 858 ROVER 1116, 1120 VAUXHALL 1358				
AX190	NISSAN 744	AY570	ALFA ROMEO 10, 12, 20, 28, 34, 38 CHRYSLER 184, 190 FORD 460 JEEP 562, 564, 566 OPEL 858 ROVER 1116, 1120 VAUXHALL 1358				
AX270	FORD 470	AY580	ALFA ROMEO 10, 12, 20, 28, 34, 38 CHRYSLER 184, 190 FORD 460 JEEP 562, 564, 566 OPEL 858 ROVER 1116, 1120 VAUXHALL 1358				
AY060	AUDI 56, 64, 80, 88, 90, 92, 98	AY590	ALFA ROMEO 10, 12, 20, 28, 34, 38 CHRYSLER 184, 190 FORD 460 JEEP 562, 564, 566 OPEL 858 ROVER 1116, 1120 VAUXHALL 1358				
AY070	CITROËN 244, 260, 266, 268, 276, 284 FIAT 398 LANCIA 604 PEUGEOT 944, 958, 966, 972	AY600	ALFA ROMEO 10, 12, 20, 28, 34, 38 CHRYSLER 184, 190 FORD 460 JEEP 562, 564, 566 OPEL 858 ROVER 1116, 1120 VAUXHALL 1358				
AY090	CITROËN 266, 282 PEUGEOT 944, 956	AY610	ALFA ROMEO 10, 12, 20, 28, 34, 38 CHRYSLER 184, 190 FORD 460 JEEP 562, 564, 566 OPEL 858 ROVER 1116, 1120 VAUXHALL 1358				
AY100	CITROËN 266, 282 PEUGEOT 944, 956	AY620	ALFA ROMEO 10, 12, 20, 28, 34, 38 CHRYSLER 184, 190 FORD 460 JEEP 562, 564, 566 OPEL 858 ROVER 1116, 1120 VAUXHALL 1358				
AY110	CITROËN 212 PEUGEOT 926	AY630	ALFA ROMEO 10, 12, 20, 28, 34, 38 CHRYSLER 184, 190 FORD 460 JEEP 562, 564, 566 OPEL 858 ROVER 1116, 1120 VAUXHALL 1358				
AY120	CITROËN 258, 272, 280 PEUGEOT 926, 936, 940	AY640	ALFA ROMEO 10, 12, 20, 28, 34, 38 CHRYSLER 184, 190 FORD 460 JEEP 562, 564, 566 OPEL 858 ROVER 1116, 1120 VAUXHALL 1358				
AY160	OPEL 840 VAUXHALL 1330, 1336	AY660	ALFA ROMEO 10, 12, 20, 28, 34, 38 CHRYSLER 184, 190 FORD 460 JEEP 562, 564, 566 OPEL 858 ROVER 1116, 1120 VAUXHALL 1358				
AY170	OPEL 840 VAUXHALL 1330, 1336	AY680	ALFA ROMEO 10, 12, 20, 28, 34, 38 CHRYSLER 184, 190 FORD 460 JEEP 562, 564, 566 OPEL 858 ROVER 1116, 1120 VAUXHALL 1358				
AY180	OPEL 840 VAUXHALL 1330, 1336	AY690	ALFA ROMEO 10, 12, 20, 28, 34, 38 CHRYSLER 184, 190 FORD 460 JEEP 562, 564, 566 OPEL 858 ROVER 1116, 1120 VAUXHALL 1358				
AY200	LAND ROVER 612, 616						

NUMERICAL PARTS LIST









Numerische Teilenummernliste • Liste des références produits
Lista de referencias









								
BC270	NISSAN	784, 814	BF350	RENAULT	1060	BH860	OPEL	850, 852, 860, 868
BC370	ALFA ROMEO	8, 32	BF570	PEUGEOT	938		VAUXHALL	1320, 1362
BC380	NISSAN	790, 792, 796, 800	BF580	PEUGEOT	962, 984	BH870	MERCEDES-BENZ	664, 680, 682
BC630	TRIUMPH	1312	BF600	CITROËN	232	BH880	MERCEDES-BENZ	664, 684, 696, 714, 716, 718
BC650	SAAB	1124	BF730	RENAULT	1062	BH950	CITROËN	220, 224, 226, 254, 262
BC790	MERCEDES-BENZ	664, 686, 696, 714, 716, 718	BG120	RENAULT	1078		PEUGEOT	922, 924, 928, 930
BC800	MERCEDES-BENZ	688, 696, 714, 716		TALBOT	1242		TALBOT	1240
BC820	MERCEDES-BENZ	686	BG130	RENAULT	1078	BJ020	JAGUAR	552, 554
BC910	BMW	122		TALBOT	1242	BJ170	BEDFORD	112
BC920	BMW	122, 124, 144	BG170	JEEP	564, 568		OPEL	858, 868, 870, 876, 878
BC930	BMW	148, 154, 158, 160		PEUGEOT	964		VAUXHALL	1342, 1344, 1358, 1368
BC940	BMW	162		RENAULT	1032, 1034, 1040, 1050, 1070, 1074, 1076, 1078, 1088, 1090	BJ200	FORD	412, 418
BC990	TOYOTA	1256	BG450	CITROËN	230, 240	BJ350	NISSAN	788, 802
BD010	MAZDA	744		FIAT	330, 340	BJ360	NISSAN	802
BD040	MITSUBISHI	740, 746		PEUGEOT	984	BJ420	MAZDA	638
BD070	VOLVO	1384, 1386, 1388, 1392, 1394, 1398	BG480	CITROËN	224	BJ430	MAZDA	638, 640, 652
				PEUGEOT	928, 948	BJ440	FORD	414, 416, 418, 428, 430, 450, 452, 462
BD360	ISUZU	524		TALBOT	1236	BJ600	MITSUBISHI	744, 746, 752, 754, 762, 766
BD620	AUDI	64, 98	BG490	CITROËN	226	BJ610	HONDA	482
	VW	1532		PEUGEOT	928, 930, 948	BJ630	DAIHATSU	304, 306
BD630	BMW	130, 132, 146		TALBOT	1236, 1238, 1240, 1242	BJ650	ISUZU	520, 522, 526
BD760	TOYOTA	1264, 1278	BG540	CITROËN	232	BJ660	TOYOTA	1264, 1278, 1298
BD790	FIAT	316, 324		FIAT	316	BJ740	TOYOTA	1264, 1282, 1290
BD950	DAIHATSU	302	BG670	DAIHATSU	304	BJ850	FIAT	374, 380, 386, 402
	TOYOTA	1264, 1266, 1286, 1292, 1302, 1304, 1306		TOYOTA	1268, 1278, 1302		ZASTAVA	1554
BD970	AUSTIN	104, 108	BG710	TRIUMPH	1312	BJ860	FIAT	316, 348, 364, 366, 402, 404
	LEYLAND / LDV	626	BG720	NISSAN	788, 794, 802, 820	BJ870	FIAT	316, 348, 364, 366, 402, 404
	MORRIS	774	BG740	SUBARU	1212, 1214	BJ880	FIAT	316, 348, 364, 366, 402, 404
BD980	MITSUBISHI	752	BG820	FIAT	372, 376	BJ890	MITSUBISHI	752, 762, 766, 772
BE070	MITSUBISHI	742	BG830	FIAT	372, 376	BK020	OPEL	878
BE120	HONDA	496, 498	BG870	VW	1486, 1500	BK040	ISUZU	522
BE360	MAZDA	652	BG900	JEEP	562, 564	BK100	HONDA	496, 498
BE390	TOYOTA	1282		RENAULT	1032, 1034, 1040, 1050, 1070, 1076, 1078, 1082, 1090	BK410	MITSUBISHI	742, 744, 746, 748, 752, 754, 758, 760, 772
BE410	MITSUBISHI	740, 750	BG940	VW	1492	BK420	MITSUBISHI	744
BE440	FIAT	320, 324, 354	BG990	MERCEDES-BENZ	680, 698	BK440	NISSAN	790, 792, 794, 806, 810, 814, 816
BE450	FIAT	320, 324, 354	BH060	MITSUBISHI	744, 748, 752, 762, 766, 770, 772	BK450	AUSTIN	104, 106, 108
BE460	FIAT	320, 324, 354	BH080	JEEP	562, 564		MG	726
BE540	FORD	412		RENAULT	1032, 1034, 1040, 1050, 1070, 1076, 1078, 1082, 1090		ROVER	1116, 1118
BE550	SUZUKI	1222, 1224	BH090	JEEP	562, 564	BK460	TOYOTA	1264, 1278, 1280, 1302
BE580	ALFA ROMEO	34, 36		RENAULT	1032, 1034, 1040, 1050, 1070, 1076, 1078, 1082, 1090	BK470	BEDFORD	110
	FIAT	318, 324, 340, 356					OPEL	828, 830, 852, 860, 862, 868
	IVECO	534, 538, 540, 544					VAUXHALL	1322, 1336, 1344, 1362, 1364
	RENAULT	1050, 1052, 1090				BK480	NISSAN	786, 806, 814
BE620	ALFA ROMEO	6, 12, 32, 36					OPEL	830, 862, 864
	NISSAN	790					VAUXHALL	1328, 1338, 1346
BE880	JAGUAR	552, 554, 556	BH680	RENAULT	1024, 1034, 1036, 1038, 1060, 1062, 1064, 1066, 1078, 1080	BK500	ISUZU	520, 524
BE890	JAGUAR	552, 554, 556	BH690	RENAULT	1036, 1038, 1040, 1062, 1064, 1066, 1070, 1074, 1078, 1088	BK501	ISUZU	520, 522, 526
BF100	CITROËN	224				BK502	ISUZU	520, 522, 526
	PEUGEOT	928, 948				BK503	ISUZU	520, 522, 526
	TALBOT	1236				BK540	FIAT	316, 376
BF110	TALBOT	1236					LANCIA	600
BF170	CITROËN	226						
	PEUGEOT	928, 930, 948	BH700	LADA	578, 580			
	TALBOT	1236, 1238, 1240, 1242	BH720	VW	1504, 1540			
BF290	CITROËN	254	BH730	VW	1504, 1540			
	PEUGEOT	922, 928	BH740	SUZUKI	1220, 1222			
	TALBOT	1240	BH850	ALFA ROMEO	8, 10, 32, 36			

								
BL410	FORD	412, 460, 466	BM370	BEDFORD	112	BN140	FORD	462
BL450	HYUNDAI	510		ISUZU	520, 528	BN150	FORD	458, 462
	MITSUBISHI	744, 770, 772		OPEL	846	BN170	NISSAN	790
BL550	OPEL	850, 860		SSANGYONG	1204	BN190	BEDFORD	112
	VAUXHALL	1362, 1364		VAUXHALL	1340		ISUZU	520, 522
BL560	VW	1518	BM380	OPEL	830, 866, 868, 878	BN200	TOYOTA	1266, 1268, 1282, 1302, 1304, 1306
BL570	SEAT	1148, 1156, 1158		VAUXHALL	1330, 1340, 1342, 1348	BN220	MITSUBISHI	744, 748, 758, 760, 766, 770
	VW	1464, 1486, 1516, 1518, 1546	BM450	DAIHATSU	304	BN230	MITSUBISHI	742, 756, 760
BL610	PEUGEOT	964	BM480	TOYOTA	1264, 1276, 1278, 1280		PROTON	990
	TALBOT	1236, 1238, 1242	BM490	ISUZU	520, 524, 526, 528	BN240	HONDA	482
BL620	CITROËN	220, 224, 226, 254, 262	BM530	CITROËN	230	BN320	PEUGEOT	962, 984
	PEUGEOT	922, 924, 928, 930		FIAT	338	BN330	HYUNDAI	504, 508
	TALBOT	1240	BM570	NISSAN	780, 782, 790, 792, 796, 800, 804, 812, 820		MITSUBISHI	742, 754, 756, 760
BL650	CITROËN	216, 220, 222, 244, 258, 262, 264, 274, 280, 282	BM580	NISSAN	788, 802, 804, 820	BN360	RENAULT	1062, 1064, 1066
	FIAT	396	BM590	NISSAN	786, 806, 812	BN390	TOYOTA	1256, 1260, 1268, 1270, 1276, 1292, 1294, 1302, 1304, 1308
	PEUGEOT	932, 934, 938, 940, 950, 952, 954, 956, 970, 980	BM690	VW	1540, 1542	BN450	HONDA	478, 496, 498
BL680	BMW	136, 148, 150, 170	BM740	SUZUKI	1224, 1226	BN470	FORD	418, 430
BL690	BMW	156, 160, 162, 164	BM750	MITSUBISHI	740, 746, 750	BN480	SUZUKI	1220, 1222, 1224, 1226, 1228, 1230
BL740	DAIHATSU	304	BM760	NISSAN	780, 786, 788, 790, 794, 806, 812, 814	BN530	TOYOTA	1304
	TOYOTA	1256, 1268	BM790	RENAULT	1024, 1034, 1036, 1038, 1060, 1062, 1064, 1066, 1078, 1080	BN550	SUBARU	1214, 1216
BL760	NISSAN	798	BM800	RENAULT	1036, 1038, 1040, 1062, 1064, 1066, 1070, 1074, 1078, 1088	BN560	SUBARU	1210, 1214, 1216
BL770	NISSAN	788, 792, 802, 804		VOLVO	1384, 1386	BN570	CITROËN	224, 254, 262
BL820	DAIHATSU	306, 308	BM820	NISSAN	784, 788		PEUGEOT	922, 928
	TOYOTA	1280, 1282, 1284, 1286, 1292, 1294, 1302	BM830	MITSUBISHI	740, 744, 746, 748, 758, 766, 770, 772	BN580	CITROËN	220, 224, 226, 254, 262
BL822	TOYOTA	1280, 1282, 1284, 1286, 1292, 1294, 1302	BM840	AUDI	56, 58, 60, 62, 64, 94, 96, 98		PEUGEOT	922, 924, 928, 930
BL830	CITROËN	230, 240		VW	1512, 1514	BN600	LAND ROVER	610
	PEUGEOT	984	BM850	AUSTIN	106	BN610	ISUZU	522, 524
BL880	MAZDA	652		CARBODIES	176	BN620	KIA	572, 576
BL910	RENAULT	1028, 1064, 1066, 1068, 1072, 1074, 1088		LAND ROVER	610		MAZDA	646, 650, 652, 656
	VOLVO	1386, 1388, 1390, 1392	BM870	LEYLAND / LDV	628	BN640	DAIHATSU	306, 308
BL950	TOYOTA	1248, 1278, 1280, 1284, 1286, 1288	BM880	TOYOTA	1266, 1278, 1302, 1306		TOYOTA	1280, 1282, 1284, 1286, 1294
BL960	RENAULT	1036, 1038, 1066, 1068, 1080	BM890	TOYOTA	1248, 1264, 1278, 1286, 1288, 1298	BN670	AUSTIN	104, 108
	VOLVO	1386, 1388		VW	1538		LEYLAND / LDV	622, 626
BL970	RENAULT	1036, 1038, 1064, 1066, 1068, 1080	BM900	DAIHATSU	308, 310		MG	726, 734
	VOLVO	1386, 1388	BM910	SUZUKI	1220		ROVER	1112
BL980	RENAULT	1036, 1038, 1064, 1066, 1068, 1080	BM920	HONDA	478, 496	BN720	MERCEDES-BENZ	666, 686, 696
	VOLVO	1386, 1388	BM950	FORD	416, 432, 452	BN740	MERCEDES-BENZ	688, 690, 692, 698, 702, 704, 706
BM300	MAZDA	644	BM960	FORD	416, 432, 452	BN780	CITROËN	230
BM330	BEDFORD	112	BM980	FORD	416, 432, 452		FIAT	338
	ISUZU	530	BM990	HONDA	482, 484, 492, 494, 498		PEUGEOT	962, 964, 966, 982, 984
BM340	SUBARU	1214		ROVER	1102	BN940	AUDI	50, 56
BM360	AUDI	50, 52, 58, 94	BN010	OPEL	850		VW	1456, 1468, 1470, 1486, 1488, 1490, 1504
	SEAT	1150, 1152, 1160, 1162, 1164, 1168, 1176, 1178		VAUXHALL	1362	BN950	AUDI	50, 56
	VW	1456, 1458, 1460, 1466, 1470, 1472, 1474, 1476, 1488, 1490, 1500, 1502, 1506, 1508, 1524, 1532, 1534, 1548	BN040	OPEL	850, 860, 868		VW	1456, 1468, 1470, 1486, 1488, 1490, 1504
				VAUXHALL	1320, 1362	BN960	AUDI	50, 56
			BN080	VW	1456, 1468, 1470, 1488, 1490, 1504		VW	1456, 1468, 1470, 1486, 1488, 1490, 1504
			BN090	VW	1456, 1468, 1470, 1488, 1490, 1504	BN030	FIAT	316, 348, 362, 400
			BN100	VW	1456, 1468, 1470, 1488, 1490, 1504		SEAT	1156, 1174
						BP050	FIAT	316, 362
						BP060	FIAT	348
						BP070	ZASTAVA	1554
						BP090	ZASTAVA	1554
						BP110	FIAT	374
							LANCIA	586
							ZASTAVA	1554
						BP190	FIAT	324
						BP260	ALFA ROMEO	6, 8, 10, 12, 20, 28, 34, 38
							CHRYSLER	184, 190
							FORD	460
							JEEP	562, 566
							LAND ROVER	614
							OPEL	858
							ROVER	1116, 1120
							TOYOTA	1288
							VAUXHALL	1358
						BP270	FIAT	330
							LANCIA	598
						BP280	FIAT	326, 362, 364, 366, 380, 392, 402
							LANCIA	600, 602
						BP290	FIAT	346, 348, 402
							LANCIA	602
						BP300	FIAT	404, 406
						BP500	FIAT	362, 364
						BP510	FIAT	362, 364
						BP520	FIAT	316, 348, 362, 400
							SEAT	1156, 1174
						BP530	TOYOTA	1256, 1268
						BP540	MAZDA	640
						BP560	DAIHATSU	306, 308
						BP570	MAZDA	642
						BP580	NISSAN	782, 792, 810, 818
						BP600	KIA	574, 576
							MAZDA	640, 642
						BP610	BMW	122, 124, 144
						BP620	BMW	148, 154, 160
						BP630	HONDA	486, 492, 494, 498
						BP640	ACURA	2
							HONDA	494
							ROVER	1116
						BP650	TOYOTA	1248, 1280, 1284, 1286, 1294, 1304, 1306
						BP660	FIAT	362
						BP730	SUBARU	1212, 1214
						BP740	HONDA	496
						BP760	PEUGEOT	938
						BP780	SUZUKI	1220, 1222
						BP800	BEDFORD	110
							DAEWOO	290, 294
							OPEL	830, 836, 838, 856, 864, 884, 886
							VAUXHALL	1324, 1326, 1328, 1336, 1338, 1346, 1364, 1372

NUMERICAL PARTS LIST









Numerische Teilenummernliste • Liste des références produits
Lista de referencias









							
BP810	DAEWOO 290, 296 OPEL 830, 864, 866, 872, 886, 888 VAUXHALL 1330, 1338, 1340, 1342, 1348	BR140	DAIHATSU 304, 306	BR760	DAIHATSU 302	BS360	TOYOTA 1248, 1288, 1298, 1306
BP820	DAEWOO 290 OPEL 832, 844, 858, 866, 872, 874, 888, 890 VAUXHALL 1332, 1334, 1340, 1342, 1344, 1348, 1356, 1366	BR160	NISSAN 798	BR780	CITROËN 222, 274 PEUGEOT 932, 950, 954 ROVER 1106, 1110	BS370	TOYOTA 1248, 1288, 1298, 1306
BP840	MAZDA 656	BR190	BEDFORD 522, 526	BR790	CITROËN 222, 274 PEUGEOT 932, 950, 954 ROVER 1106, 1110	BS430	DAIHATSU 302
BP860	FIAT 350, 372, 374, 402, 404 LANCIA 596	BR200	ISUZU 520, 526, 528 OPEL 846 VAUXHALL 1340	BR830	BMW 122, 124, 126, 144, 170	BS460	KIA 572, 576 MAZDA 650, 652, 656
BP870	ZASTAVA 1554	BR240	NISSAN 810, 816	BR840	BMW 130, 132, 146	BS520	RENAULT 1030, 1036, 1040, 1056, 1072, 1074, 1080
BP880	LEYLAND / LDV 624 ROVER 1118	BR250	TOYOTA 1252, 1258, 1294, 1296	BR850	KIA 574, 576 MAZDA 646, 648, 652	BS530	RENAULT 1030, 1036, 1040, 1056, 1072, 1074, 1080
BP890	FORD 444, 458, 460, 466 LEYLAND / LDV 622, 624 PEUGEOT 964, 966, 984 SSANGYONG 1204 TALBOT 1242	BR270	TOYOTA 1268, 1292	BR870	NISSAN 814	BS540	RENAULT 1030, 1036, 1040, 1056, 1072, 1074, 1080
BP900	FORD 444, 458, 460, 466 LEYLAND / LDV 622, 624 PEUGEOT 964, 966, 984 SSANGYONG 1204 TALBOT 1242	BR280	CITROËN 240	BR880	DAIHATSU 302, 306, 308, 310	BS600	SUZUKI 1222, 1228
BP910	FORD 444, 458, 460, 466 LEYLAND / LDV 622, 624 PEUGEOT 964, 966, 984 SSANGYONG 1204 TALBOT 1242	BR290	LAND ROVER 612, 616	BR890	TOYOTA 1252, 1264, 1290	BS610	NISSAN 810, 816
BP920	BEDFORD 112 ISUZU 520, 528 OPEL 846 VAUXHALL 1340	BR300	TOYOTA 1264, 1280, 1304	BR900	TOYOTA 1256, 1270, 1294, 1302	BS620	LADA 578, 580
BP950	NISSAN 782, 814	BR330	TOYOTA 1260, 1262, 1296	BR920	ISUZU 520	BS630	LADA 578, 580
BP960	NISSAN 780, 782, 806, 808, 812, 816, 820	BR360	NISSAN 786, 812, 820, 822	BR940	ISUZU 520, 528	BS700	HONDA 478, 480, 496 ROVER 1112
BP970	NISSAN 780, 806, 816	BR420	BMW 136, 148	BR950	TOYOTA 1282, 1308	BS720	LADA 578 OPEL 842, 844, 866, 888, 890 VAUXHALL 1334, 1340, 1350
BP980	BEDFORD 112 ISUZU 520 VAUXHALL 1360	BR430	BMW 136, 148	BR960	KIA 574 MAZDA 636, 638, 640	BS730	CITROËN 214, 278 PEUGEOT 926
BP990	ALFA ROMEO 8	BR440	BMW 136, 148	BR970	MAZDA 650, 654	BS760	NISSAN 788, 820
BR010	BEDFORD 112 OPEL 858, 874, 876, 878, 880 VAUXHALL 1344, 1358, 1368	BR490	CITROËN 212, 214, 256, 258, 278 PEUGEOT 924, 928, 984, 986	BR980	MAZDA 650, 654	BS770	FORD 446 NISSAN 780, 784, 792, 804, 806, 812, 818
BR020	BEDFORD 112 OPEL 858, 874, 876, 878, 880 VAUXHALL 1344, 1358, 1368	BR510	CITROËN 216, 220, 222, 224, 244, 258, 262, 264, 274, 280, 282 FIAT 396 PEUGEOT 932, 934, 938, 940, 950, 952, 954, 956, 970, 980, 494, 498	BR990	ISUZU 520, 522, 528 OPEL 846, 858 VAUXHALL 1340, 1358	BS790	LAND ROVER 612 ROVER 1106, 1110, 1114
BR030	BEDFORD 112 OPEL 858, 874, 876, 878, 880 VAUXHALL 1344, 1358, 1368	BR540	HONDA 482, 484, 486, 490, 492, 494, 498	BS010	RENAULT 1036, 1038, 1064, 1066, 1068, 1080 VOLVO 1386, 1388	BS810	CITROËN 212, 214, 256, 258, 278 PEUGEOT 924, 928, 986
BR070	ALFA ROMEO 34, 36 FIAT 340, 342 IVECO 540, 542, 546 RENAULT 1052	BR560	SUBARU 1212, 1214, 1216	BS020	RENAULT 1036, 1038, 1064, 1066, 1068, 1080 VOLVO 1386, 1388	BS820	CITROËN 248, 268 PEUGEOT 966
BR090	FIAT 330 LANCIA 598	BR570	TOYOTA 1290	BS030	RENAULT 1036, 1038, 1064, 1066, 1068, 1080 VOLVO 1386, 1388	BS830	INFINITI 516 NISSAN 802
BR110	FIAT 404	BR600	CHRYSLER 184, 186, 190 HYUNDAI 506, 512 MITSUBISHI 744, 746, 750, 764, 766	BS050	NISSAN 786, 814, 818	BS840	INFINITI 516
BR120	FIAT 404	BR620	FIAT 350, 360, 382, 388, 392, 404 LANCIA 586 ZASTAVA 1554	BS060	TOYOTA 1258, 1262, 1296	BS860	ROVER 1108, 1112, 1114
		BR630	CITROËN 240, 250 FIAT 350, 366, 368, 376, 388, 390, 392 LANCIA 584, 588 PEUGEOT 978	BS070	MAZDA 642, 654	BS870	TOYOTA 1298
		BR650	HONDA 494 ROVER 1116	BS090	DAIHATSU 306, 310	BS880	HONDA 486, 488, 490, 492 ROVER 1104, 1108
		BR660	NISSAN 800, 802, 804, 818, 820, 822	BS110	HONDA 478, 496	BS890	HONDA 494, 496
		BR670	DAIHATSU 302	BS120	HYUNDAI 510 MITSUBISHI 746, 748, 750	BS910	NISSAN 782
		BR680	ALFA ROMEO 14, 16, 18 FIAT 336, 350, 360, 370, 374, 376, 386, 388, 390, 396 LANCIA 586, 588	BS130	HYUNDAI 506, 508, 512 KIA 574 MITSUBISHI 746, 750, 752, 754, 762, 766, 768	BS940	MAZDA 654, 656
		BR690	FIAT 336, 374, 376 LANCIA 586, 588, 596	BS200	NISSAN 788, 804, 818, 820	BS950	MAZDA 642, 644, 654
		BR700	FIAT 336, 374, 376 LANCIA 586, 588, 596	BS240	HYUNDAI 508 MITSUBISHI 742, 744, 758, 760	BS953	MAZDA 654
		BR730	MAZDA 644, 646, 648, 650, 656	BS260	DAEWOO 292 OPEL 832, 834, 848, 854, 862, 884 VAUXHALL 1322, 1324, 1334, 1338, 1346, 1350, 1354, 1355, 1364	BS970	TOYOTA 1252, 1254, 1258, 1262, 1294, 1296, 1298, 1300
		BR750	TOYOTA 1256, 1260, 1268, 1270, 1294	BS280	MAZDA 650, 654	BT020	VW 1540
				BS290	LEXUS 618 TOYOTA 1254	BT070	JAGUAR 552, 554, 556
				BS300	LEXUS 618 TOYOTA 1254	BT080	DACIA 286 RENAULT 1040, 1068
				BS320	BMW 156, 162	BT110	FORD 426, 444
						BT130	TOYOTA 1248, 1278, 1280, 1284, 1286, 1288
						BT140	FORD 414, 428, 444, 450 MAZDA 636
						BT190	FORD 420, 422, 434, 454, 456, 464
						BT200	FORD 420, 422, 434, 454, 456, 464

											
BT210	FORD	420, 422, 434, 454, 456, 464	BT900	SUZUKI	1224, 1226	BV690	ALFA ROMEO	14, 16, 18, 34	BW370	MERCEDES-BENZ 710, 712, 714, 716, 718, 720, 722	
BT220	FIAT	320, 322, 336, 348, 350, 370, 372, 376, 386, 390, 394, 406	BV010	MITSUBISHI	740, 746, 764, 766		FIAT	336, 350, 360, 370, 386, 388, 390, 396		SSANGYONG	1204, 1206
BT230	FIAT	320, 322, 348, 350, 370, 372, 376, 390, 394, 406	BV020	HONDA	486, 488, 492	BV700	ALFA ROMEO	14, 16, 18, 34	BW380	DAEWOO	292, 294
BT240	FIAT	320, 322, 348, 350, 370, 372, 376, 390, 394, 406	BV030	HONDA	480, 498		FIAT	336, 350, 360, 370, 386, 388, 390, 396		MERCEDES-BENZ 688, 696, 700, 712, 714, 716, 718	
BT260	FIAT	326, 362, 380	BV040	HONDA	486, 488, 490, 492, 494	BV830	HONDA	478, 480		SSANGYONG	1204, 1206
BT300	FIAT	328	BV050	HONDA	492	BV850	AUDI	52	BW410	ALFA ROMEO	18, 20, 26
BT320	FIAT	328	BV090	ACURA	2		SEAT	1152, 1164, 1170, 1178	BW420	NISSAN	784, 808, 818
BT340	ALFA ROMEO	6, 12, 14		HONDA	494		SKODA	1188	BW460	TOYOTA	1276
BT350	ALFA ROMEO	8, 26, 42	BV100	ACURA	2		VW	1458, 1476, 1478, 1508, 1510, 1528, 1530, 1542, 1550	BW540	NISSAN	788, 804, 820
BT360	ALFA ROMEO	8, 32, 36, 38, 40, 42	BV110	KIA	574	BV860	AUDI	52	BW560	TOYOTA	1282
BT380	ALFA ROMEO	18, 24, 28, 30, 38, 40, 44		MAZDA	642, 654, 656		SEAT	1152, 1164, 1170, 1178	BW620	NISSAN	790, 792, 796, 800
	LANCIA	600	BV140	CITROËN	244, 246, 254, 260, 266, 268, 282		SKODA	1188	BW630	FORD	416, 418, 430, 446, 452
BT390	ALFA ROMEO	28		FIAT	338, 398		VW	1458, 1476, 1478, 1508, 1510, 1528, 1530, 1542, 1550	BW640	FORD	420, 432, 446, 452
BT400	FIAT	350, 368, 404	BV150	CITROËN	268	BV870	AUDI	52	BW650	FORD	448
BT410	FIAT	328, 330, 348, 372, 388, 392		PEUGEOT	968		SEAT	1152, 1164, 1170, 1178	BW680	VOLVO	1384, 1394, 1396, 1400
	LANCIA	584, 586, 596, 598	BV160	CITROËN	268		SKODA	1188		VW	1492, 1494
BT420	ALFA ROMEO	26		PEUGEOT	968	BV880	VW	1544	BW690	VOLVO	1384, 1394, 1396, 1400
	FIAT	328, 330, 372, 388, 392	BV190	RENAULT	1024, 1036, 1038, 1078, 1090	BV940	FIAT	326, 362, 364, 366, 380, 392, 402		VW	1492, 1494
	LANCIA	584, 586, 588, 590, 598	BV250	NISSAN	790, 802		LANCIA	600, 602	BW700	VOLVO	1384, 1394, 1396, 1400
BT430	HYUNDAI	504, 508, 510	BV310	NISSAN	780, 784, 790, 792, 800, 802, 820	BV950	OPEL	876, 880		VW	1492, 1494
	MITSUBISHI	742, 754, 756, 760	BV330	TOYOTA	1266, 1268, 1282, 1296, 1304, 1306		VAUXHALL	1344, 1368	BW710	ALFA ROMEO	14, 16, 20, 22, 28, 40, 42
	PROTON	990, 992	BV340	HONDA	498	BV990	NISSAN	810, 814			
BT440	ALFA ROMEO	20, 26	BV350	ACURA	2	BW010	FORD	422, 424, 434, 436, 448, 454, 456, 464	BW720	ALFA ROMEO	12, 14, 18, 20, 22, 38, 40, 42
	FIAT	326, 328, 390, 394, 396, 400		HONDA	482, 486, 488, 490, 492		MAZDA	638		FIAT	318, 320, 322, 326, 354, 370
	LANCIA	584, 586, 588, 590, 596, 598	BV360	HONDA	480, 498		MAZDA	638		LANCIA	584, 588, 592
BT470	AUDI	60	BV370	TOYOTA	1250, 1256, 1266, 1268, 1302	BW020	FORD	422, 424, 434, 436, 448, 454, 456, 464	BW730	BMW	138, 152, 154
BT480	FORD	458, 466	BV380	MAZDA	642, 644, 646, 654, 656		MAZDA	638	BW740	BMW	138, 152, 153, 154
BT510	FORD	462, 466, 472	BV410	MAZDA	648, 656, 658	BW030	FORD	422, 424, 434, 436, 448, 454, 456, 464	BW750	LAND ROVER	614
BT520	FORD	462, 466, 472	BV420	MAZDA	648, 656, 658		MAZDA	638		LOTUS	630
BT530	OPEL	870, 876, 880	BV430	KIA	574	BW170	OPEL	846, 850		MG	726, 728, 730, 732
	VAUXHALL	1344, 1368	BV440	NISSAN	780, 782, 806, 808, 812, 816, 820		VAUXHALL	1350, 1352, 1362	BW770	VW	1540, 1542
BT540	MERCEDES-BENZ	664, 670, 680, 682	BV450	SUBARU	1214	BW220	MERCEDES-BENZ	704, 706	BW800	TOYOTA	1278, 1280, 1282, 1284, 1286, 1288, 1308
BT550	MERCEDES-BENZ	690, 692, 696	BV460	SEAT	1174	BW260	ALFA ROMEO	10, 28, 44			
BT560	SAAB	1124, 1126, 1128, 1130		VW	1520, 1522		LANCIA	600	BW950	TOYOTA	1284, 1288, 1308
BT580	SKODA	1186, 1188	BV470	SEAT	1174	BW280	ALFA ROMEO	10, 26, 28, 40, 42	BW980	ALFA ROMEO	14, 16, 18
BT630	TOYOTA	1264, 1276, 1278, 1280		VW	1520, 1522	BW290	ALFA ROMEO	10, 26, 40, 42		FIAT	336, 350, 360, 370, 386, 388, 390, 396
BT680	BMW	130, 146	BV480	SEAT	1174	BW300	ALFA ROMEO	10, 12, 20	BW5750	LAND ROVER	614
BT690	BMW	134, 136, 140, 148, 150, 156, 160, 172		VW	1520, 1522		FIAT	330		LOTUS	630
BT800	FORD	470, 472	BV540	INFINITI	516	BW310	ALFA ROMEO	10, 12, 20		MG	726, 728, 730, 732
	LEYLAND / LDV	624		NISSAN	780, 796, 808, 812, 818		FIAT	330	BX010	TOYOTA	1258, 1270, 1272, 1292, 1306
BT810	AUDI	52, 54, 60, 84, 92, 96	BV670	FIAT	332, 358, 360, 364, 368, 382, 386	BW320	FIAT	324, 326, 356	BX020	TOYOTA	1254, 1258, 1308
	SEAT	1154, 1156, 1166, 1180, 1182		LANCIA	600, 604		LANCIA	590, 594	BX030	FIAT	318, 322, 354, 358, 360
	VW	1462, 1484, 1512, 1550	BV680	ALFA ROMEO	14, 16, 18, 34	BW330	LANCIA	590		LANCIA	584, 586, 588, 592
BT820	AUDI	54, 56, 62, 66, 86, 92, 98		FIAT	336, 350, 360, 370, 374, 376, 386, 388, 390, 396	BW340	FIAT	356	BX040	FIAT	318, 322, 352
BT860	FIAT	316, 324		LANCIA	586, 588		LANCIA	592		LANCIA	602
BT880	MITSUBISHI	750, 754				BW350	FIAT	356	BX060	TOYOTA	1284
BT890	MITSUBISHI	740, 742, 744, 748, 756, 758, 768					LANCIA	592	BX080	VOLVO	1390, 1392
	PROTON	990				BW360	FIAT	356	BX090	VOLVO	1394, 1398, 1400
							LANCIA	592	BX270	BMW	158, 164, 166

NUMERICAL PARTS LIST









Numerische Teilenummernliste • Liste des références produits
Lista de referencias









																			
BX280	BMW	158, 164, 166	BX800	AUDI	52, 76, 78, 84, 92	BX880	CITROËN	218, 224, 230, 240, 246, 250, 254, 264, 276, 282	BX940	CITROËN	242, 244, 246, 252, 254, 260, 266, 276, 282								
BX290	BMW	158, 164, 166		FORD	442		FIAT	334, 378		FIAT	336, 338, 378, 396								
BX300	BMW	158, 164, 166		SEAT	1140, 1146, 1152, 1154, 1162, 1164, 1166, 1170, 1180		HYUNDAI	508		PEUGEOT	944, 956, 958, 970, 976, 980								
BX390	CITROËN	248, 250, 256		VW	1456, 1458, 1460, 1478, 1482, 1496, 1510, 1526, 1528, 1530, 1532, 1536, 1550		LADA	578		SUZUKI	1220, 1226, 1230								
	FIAT	344, 346		BX810	AUDI	52, 76, 78, 84, 92		LEYLAND / LDV	622, 624	BX950	CITROËN	242, 244, 246, 252, 254, 260, 266, 276, 282							
	IVECO	536, 538, 542, 544, 546, 548			FORD	442		PEUGEOT	934, 940, 942, 952, 954, 976, 980, 982, 988		FIAT	336, 338, 378, 396							
	PEUGEOT	978			SEAT	1140, 1146, 1152, 1154, 1162, 1164, 1166, 1170, 1180		ROVER	1106, 1110		PEUGEOT	944, 956, 958, 970, 976, 980							
	RENAULT	1052			VW	1456, 1458, 1460, 1478, 1482, 1496, 1510, 1526, 1528, 1530, 1532, 1536, 1550		SUZUKI	1230		SUZUKI	1220, 1226, 1230							
	VAUXHALL	1362		BX820	AUDI	52, 76, 78, 84, 92		TALBOT	1238		BX960	CITROËN	242, 244, 246, 252, 254, 260, 266, 276, 282						
BX400	CITROËN	248, 250, 256			FORD	442		BX890	CITROËN	218, 224, 230, 240, 246, 250, 254, 264, 276, 282		FIAT	334, 378						
	FIAT	344, 346			SEAT	1140, 1146, 1152, 1154, 1162, 1164, 1166, 1170, 1180			FIAT	334, 378		FIAT	336, 338, 378, 396						
	IVECO	536, 538, 542, 544, 546, 548			VW	1456, 1458, 1460, 1478, 1482, 1496, 1510, 1526, 1528, 1530, 1532, 1536, 1550			LADA	578		PEUGEOT	944, 956, 958, 970, 976, 980						
	OPEL	872		BX830	AUDI	52, 76, 78, 84, 92			LEYLAND / LDV	622, 624		SUZUKI	1220, 1226, 1230						
	PEUGEOT	978			FORD	442			PEUGEOT	934, 940, 942, 952, 954, 976, 980, 982, 988		BX970	CITROËN	242, 244, 246, 252, 254, 260, 266, 276, 282					
	RENAULT	1052			SEAT	1140, 1146, 1152, 1154, 1162, 1164, 1166, 1170, 1180			ROVER	1106, 1110			FIAT	336, 338, 378, 396					
	VAUXHALL	1362			VW	1456, 1458, 1460, 1478, 1482, 1496, 1510, 1526, 1528, 1530, 1532, 1536, 1550			SUZUKI	1230			PEUGEOT	944, 956, 958, 970, 976, 980					
BX410	CITROËN	248, 250, 256		BX840	CITROËN	216, 222, 226, 264, 272, 280		BX900	CITROËN	218, 224, 230, 240, 246, 250, 254, 264, 276, 282		BX980	CITROËN	242, 244, 246, 252, 254, 260, 266, 276, 282					
	FIAT	344, 346			HONDA	490			FIAT	334, 378			FIAT	336, 338, 378, 396					
	IVECO	536, 538, 542, 544, 546, 548			PEUGEOT	932, 942, 950, 986			LADA	578			PEUGEOT	944, 956, 958, 970, 976, 980					
	OPEL	872			TALBOT	1238			LEYLAND / LDV	622, 624			SUZUKI	1220, 1226, 1230					
	PEUGEOT	978		BX850	CITROËN	216, 222, 226, 264, 272, 280			PEUGEOT	934, 940, 942, 952, 954, 976, 980, 982, 988		BY030	DACIA	286					
	RENAULT	1052			HONDA	490			ROVER	1106, 1110			RENAULT	1028, 1056, 1086					
	VAUXHALL	1362			PEUGEOT	932, 942, 950, 986			SUZUKI	1230									
BX420	CITROËN	248, 250, 256			TALBOT	1238			TALBOT	1238			BY070	RENAULT	1048				
	FIAT	344, 346		BX860	CITROËN	216, 222, 226, 264, 272, 280			BX910	CITROËN	218, 224, 230, 240, 246, 250, 254, 264, 276, 282								
	IVECO	536, 538, 542, 544, 546, 548			HONDA	490				FIAT	334, 378			BY080	RENAULT	1048			
	OPEL	872			PEUGEOT	932, 942, 950, 986				LADA	578			BY120	CITROËN	214, 278			
	PEUGEOT	978			TALBOT	1238				LEYLAND / LDV	622, 624				PEUGEOT	926			
	RENAULT	1052		BX870	CITROËN	216, 222, 226, 264, 272, 280				PEUGEOT	934, 940, 942, 952, 954, 976, 980, 982, 988				ROVER	1102			
	VAUXHALL	1362			HONDA	490				ROVER	1106, 1110			BY130	CITROËN	212, 214, 220, 226, 258, 278			
BX480	FORD	462			PEUGEOT	932, 942, 950, 986				SUZUKI	1230				PEUGEOT	930, 948			
BX550	FORD	458, 466, 470			TALBOT	1238				TALBOT	1238			BY140	CITROËN	248, 256, 270			
BX570	RENAULT	1080, 1082		BX880	CITROËN	216, 222, 226, 264, 272, 280				BX920	CITROËN	218, 224, 230, 240, 246, 250, 254, 264, 276, 282			PEUGEOT	968, 978			
BX580	RENAULT	1074, 1076			HONDA	490					FIAT	334, 378							
BX590	RENAULT	1074			PEUGEOT	932, 942, 950, 986					LADA	578			BY150	CITROËN	214, 258, 272, 280		
BX600	RENAULT	1028, 1032, 1044, 1046, 1058, 1072			TALBOT	1238					LEYLAND / LDV	622, 624				NISSAN	798		
	VOLVO	1390, 1392			BX890	CITROËN	216, 222, 226, 264, 272, 280				PEUGEOT	934, 940, 942, 952, 954, 976, 980, 982, 988				PEUGEOT	926		
BX610	RENAULT	1028, 1072			HONDA	490					ROVER	1106, 1110				ROVER	1102		
BX620	RENAULT	1030			PEUGEOT	932, 942, 950, 986					SUZUKI	1230			BY170	CITROËN	212, 214, 226, 278		
BX630	RENAULT	1024, 1042, 1090			TALBOT	1238					TALBOT	1238				PEUGEOT	926, 930, 948		
BX650	RENAULT	1048, 1082			BX900	CITROËN	216, 222, 226, 264, 272, 280				LEYLAND / LDV	622, 624							
	VOLVO	1408, 1410, 1426, 1428			HONDA	490					PEUGEOT	934, 940, 942, 952, 954, 976, 980, 982, 988				BY180	CITROËN	258, 272, 280	
BX720	RENAULT	1024, 1026, 1036, 1038, 1042, 1054, 1070, 1080			PEUGEOT	932, 942, 950, 986					ROVER	1106, 1110				PEUGEOT	926, 936, 940		
BX730	RENAULT	1024, 1026, 1036, 1038, 1042, 1054, 1070, 1080			TALBOT	1238					SUZUKI	1230			BY240	OPEL	840, 888		
BX740	RENAULT	1024, 1036, 1038, 1078, 1090			BX910	CITROËN	216, 222, 226, 264, 272, 280				TALBOT	1238				VAUXHALL	1330, 1332, 1374		
BX780	MAZDA	644, 658			HONDA	490					LEYLAND / LDV	622, 624							
BX790	MAZDA	644, 658			PEUGEOT	932, 942, 950, 986					PEUGEOT	934, 940, 942, 952, 954, 976, 980, 982, 988				BY250	CHEVROLET	178, 180	
					TALBOT	1238					ROVER	1106, 1110				DAEWOO	290, 292, 294, 296		
					BX920	CITROËN	216, 222, 226, 264, 272, 280				SUZUKI	1230				OPEL	842, 844, 858, 874, 882, 890		
					HONDA	490					TALBOT	1238				VAUXHALL	1332, 1340, 1350, 1356, 1358, 1366, 1370, 1376		
					PEUGEOT	932, 942, 950, 986					BX930	CITROËN	242, 244, 246, 252, 254, 260, 266, 276, 282						
					TALBOT	1238						FIAT	336, 338, 378, 396				BY260	OPEL	844, 890
					BX940	CITROËN	216, 222, 226, 264, 272, 280					PEUGEOT	944, 956, 958, 970, 976, 980				VAUXHALL	1340, 1350	
					HONDA	490						SUZUKI	1220, 1226, 1230						

							
BY270	OPEL 846, 876, 892	BY930	CITROËN 270	BZ170	TOYOTA 1248, 1284, 1288, 1290, 1304, 1306	BZ890	MERCEDES-BENZ 672, 678, 708
	SAAB 1126	BY941	CITROËN 246, 260, 268, 270	BZ180	SEAT 1144, 1148, 1150, 1158, 1160, 1162, 1168		SSANGYONG 1204, 1206
	VAUXHALL 1342, 1350, 1368, 1376		FIAT 400		SKODA 1188, 1190	BZ900	DAEWOO 294
BY300	OPEL 876, 882		LANCIA 606		VW 1454, 1456, 1464, 1468, 1520, 1522, 1526, 1546		MERCEDES-BENZ 672, 686, 700, 710, 712, 718, 722
	SAAB 1130, 1134	BY950	PEUGEOT 960, 968, 972	BZ280			SSANGYONG 1204, 1206
	VAUXHALL 1368, 1370		FIAT 400				VW 1492
BY310	CITROËN 246, 260, 266, 268		LANCIA 606	BZ290	HYUNDAI 512	BZ910	SEAT 1152, 1162, 1178
	FIAT 400		BY961		HYUNDAI 512		VW 1472, 1474, 1476, 1506, 1508, 1526, 1528, 1548
	LANCIA 606		CITROËN 246, 260, 268, 270	BZ300	DAEWOO 290, 294	BZ930	VOLVO 1384, 1394, 1396, 1400
	PEUGEOT 960, 968, 972		FIAT 400	BZ340	TOYOTA 1254		VW 1494
BY320	CITROËN 244, 246, 254, 260, 266, 268, 282		LANCIA 606	BZ350	TOYOTA 1254	BZ960	AUDI 78, 86
	FIAT 338, 398, 400	BY970	PEUGEOT 960, 968, 972	BZ440	HONDA 478, 490	CA3130	SEAT 1156, 1174
	LANCIA 606		FIAT 400		LAND ROVER 614	CA3140	SEAT 1160, 1174
	PEUGEOT 944, 946, 956, 960, 968, 970, 972, 978	BY981	LANCIA 606		MG 728, 730	CA5021	MINISUBISHI 764
BY330	BEDFORD 110, 112		PEUGEOT 960, 968, 972	BZ450	ROVER 1096, 1098, 1108, 1112, 1120	CA5030	MAZDA 640
	OPEL 838, 864, 886	BZ010	AUDI 70		HONDA 478, 490	CA5130	FORD 456
	VAUXHALL 1328, 1336, 1338, 1346		SKODA 1192, 1194		LAND ROVER 614	CA5130	MAZDA 650, 654
BY340	BEDFORD 110, 112		VW 1450, 1452, 1460, 1478, 1480, 1500, 1528, 1532	BZ460	MG 728, 730	CA5390	MINISUBISHI 752, 766, 768
	OPEL 838, 864, 886	BZ020	AUDI 70		ROVER 1096, 1098, 1108, 1112, 1120	CA5410	SEAT 1144, 1146, 1156
	VAUXHALL 1328, 1336, 1338, 1346		SKODA 1192, 1194		HONDA 478, 490		VW 1494, 1518
BY350	BEDFORD 110, 112		VW 1450, 1452, 1460, 1478, 1480, 1500, 1528, 1532	BZ460	LAND ROVER 614	CA5420	ALFA ROMEO 12, 14, 16, 18, 20, 22, 24, 28, 38, 40, 42
	OPEL 838, 864, 886	BZ030	AUDI 70		MG 728, 730	CA5421	FIAT 318, 370, 384
	VAUXHALL 1328, 1336, 1338, 1346		SKODA 1192, 1194	BZ490	ROVER 1096, 1098, 1108, 1112, 1120		LANCIA 592
BY360	VOLVO 1398, 1406, 1418, 1420, 1434, 1436, 1438		VW 1450, 1452, 1460, 1478, 1480, 1500, 1528, 1532	BZ500	FORD 412, 440, 448	CA5430	MERCEDES-BENZ 720
BY370	VOLVO 1396, 1398, 1402, 1404, 1414, 1416, 1418, 1420, 1430, 1432	BZ040	AUDI 70	BZ510	BMW 128, 148		VW 1462, 1486, 1516, 1538, 1552
	FIAT 318, 320, 352, 358, 366, 368, 382		SEAT 1152, 1154, 1164, 1170, 1172, 1178	BZ520	BMW 128, 148	CA5431	FORD 442
	LANCIA 602, 604		SKODA 1186, 1192, 1194	BZ630	BMW 128, 148	CA5470	VW 1492, 1542, 1544
BY390	ALFA ROMEO 12, 14		VW 1450, 1452, 1458, 1460, 1478, 1480, 1500, 1528, 1530, 1532	BZ640	JEEP 566	CA5500	SEAT 1148, 1158
BY410	FIAT 320, 324, 354	BZ050	AUDI 70	BZ650	JEEP 566		VW 1522
BY420	FIAT 320, 324, 354		SEAT 1152, 1154, 1164, 1170, 1172, 1178	BZ660	BMW 142, 156, 162, 168	CA5560	ALFA ROMEO 16, 22
BY430	FIAT 320, 324, 354		SKODA 1186, 1192, 1194		LAND ROVER 616		FIAT 320, 322, 334, 352, 354, 358, 370, 384, 386
BY460	TOYOTA 1248, 1290		VW 1450, 1452, 1458, 1460, 1478, 1480, 1500, 1528, 1530, 1532	BZ670	BMW 142, 156, 162, 168		LANCIA 594
BY470	LAND ROVER 612, 614		AUDI 70		LAND ROVER 616	CA5561	ALFA ROMEO 16, 22
BY480	LAND ROVER 612, 614		SEAT 1152, 1154, 1164, 1170, 1172, 1178	BZ680	BMW 142, 156, 162, 168		FIAT 320, 322, 332, 334, 354, 358, 370, 384, 386
BY490	LAND ROVER 612, 614		SKODA 1186, 1192, 1194		LAND ROVER 616		LANCIA 594
BY500	LAND ROVER 612, 614		VW 1450, 1452, 1458, 1460, 1478, 1480, 1500, 1528, 1530, 1532	BZ690	LAND ROVER 614	CA5590	FIAT 356, 386
BY560	BMW 126		AUDI 70		MG 730		LANCIA 594
BY580	MERCEDES-BENZ 692, 698, 702	BZ060	AUDI 70	BZ700	ROVER 1100	CA5620	VOLVO 1408, 1410, 1426, 1428
BY590	MERCEDES-BENZ 672, 686		SEAT 1152, 1154, 1164, 1170, 1172, 1178		HONDA 480	CA5630	VOLVO 1400
BY620	SEAT 1150, 1162		SKODA 1186, 1192, 1194		LAND ROVER 614	CA5640	VOLVO 1424
	VW 1468, 1546		VW 1450, 1452, 1458, 1460, 1478, 1480, 1500, 1528, 1530, 1532		MG 730	CA5641	VOLVO 1424
BY630	VW 1462, 1476, 1508		AUDI 70	BZ710	ROVER 1100		ALFA ROMEO 24, 30
BY640	FORD 426, 458		SEAT 1152, 1154, 1164, 1170, 1172, 1178		LAND ROVER 614	CA5780	LANCIA 594, 600
BY650	FORD 428		SKODA 1186, 1192, 1194		MG 730		CA5830
	MAZDA 636	BZ110	VW 1450, 1452, 1458, 1460, 1478, 1480, 1500, 1528, 1530, 1532		ROVER 1100		CITROËN 218, 228, 242, 250, 274
BY660	FORD 430, 456		AUDI 70	BZ780	JEEP 566		FIAT 378
BY730	HYUNDAI 502, 506, 508, 510		SEAT 1152, 1154, 1164, 1170, 1172, 1178		FIAT 332, 360, 370, 382, 386		PEUGEOT 936, 942, 980, 988
BY740	FORD 414, 416, 428, 450		SKODA 1186, 1192, 1194	BZ800	FIAT 332, 360, 370, 382, 386		TOYOTA 1274
BY750	AUDI 54, 62, 84, 92, 96		VW 1450, 1452, 1458, 1460, 1478, 1480, 1500, 1528, 1530, 1532	BZ810	FIAT 332, 360, 370, 382, 386	CA5920	LAND ROVER 614
	SEAT 1142, 1154, 1156, 1166, 1180, 1182		BMW 138, 152, 154, 160	BZ850	MERCEDES-BENZ 668		MG 730
	VW 1462, 1484, 1512, 1536, 1550	BZ120	BMW 138, 152, 154, 160	BZ860	MERCEDES-BENZ 672, 684		ROVER 1098, 1100
BY900	NISSAN 798		JEEP 564	BZ870	MERCEDES-BENZ 674, 686	CA5940	FORD 470
			LAND ROVER 614	BZ880	MERCEDES-BENZ 670, 672, 676, 682, 684, 708, 718, 720	CA5970	FORD 448, 470
		BZ130	VAUXHALL 1368		SSANGYONG 1204	CB5000	TOYOTA 1258, 1270, 1272, 1276, 1292, 1306
			BMW 126, 170				

NUMERICAL PARTS LIST









Numerische Teilenummernliste • Liste des références produits
Lista de referencias









							
CB5001 TOYOTA	1252, 1308	CB5700 AUDI	66	CC5231 AUDI	76, 82	CC5920 CHRYSLER	184, 186
CB5080 KIA	572	SEAT	1144, 1146, 1158, 1168, 1170, 1174	SEAT	1140, 1152, 1164, 1172	MINI	736
ROVER	1116	SKODA	1186, 1188, 1196	SKODA	1186, 1192	CC5921 MINI	736
CB5120 FORD	426, 436	VW	1448, 1454, 1466, 1496, 1498, 1520	VW	1452, 1480, 1510, 1530, 1534	CC5960 AUDI	80, 86, 88, 90, 91
MAZDA	634, 650	CB5720 FIAT	340	CC5260 JAGUAR	552	SKODA	1198
CB5130 FORD	430, 436, 456	IVECO	542	CC5261 JAGUAR	554, 558	VW	1514
CB5132 FORD	428, 440	CB5750 TOYOTA	1300, 1308, 1310	CC5262 JAGUAR	556, 558	CD770 LAND ROVER	610
MAZDA	634, 652	CB5760 TOYOTA	1250, 1260, 1266, 1268, 1272, 1294, 1300	CC5280 SEAT	1170, 1176	CD891 AUSTIN	104
CB5140 OPEL	850	CB5900 LAND ROVER	610, 612	VW	1448, 1468, 1524	CD950 MG	732
VAUXHALL	1352	CB5901 LAND ROVER	610, 612	CC5281 SEAT	1170, 1176	MORRIS	774
CB5141 OPEL	828, 848	CC5010 CITROËN	218, 236, 238, 242, 244, 246, 252, 256, 260, 266, 278	VW	1448, 1468	CD5020 FORD	428, 444
VAUXHALL	1320	FIAT	340, 380, 398, 400	CC5290 FORD	456	CD5100 CITROËN	264, 274, 282
CB5150 FIAT	322, 332, 354, 356, 360, 382	LANCIA	606	CC5350 BMW	158, 164, 166, 170	PEUGEOT	942, 956
LANCIA	592	PEUGEOT	936, 944, 948, 958, 960, 968, 972, 978, 982, 988	CC5410 BMW	120, 130, 148, 166	CITROËN	224, 228, 232, 270
CB5230 CHEVROLET	180	SUZUKI	1222	CC5440 BMW	120, 124, 128, 132, 166, 172	FORD	430, 440
DAEWOO	292, 296	CC5011 CITROËN	236, 238, 242, 244, 252, 260, 266, 278	CC5441 BMW	120, 122	MAZDA	634
CB5240 OPEL	828, 832, 850	PEUGEOT	948, 958, 968, 972, 982	CC5460 OPEL	840, 856, 870, 880, 884, 886, 888, 894	PEUGEOT	928, 934, 938, 946, 974
VAUXHALL	1320, 1352	CC5060 MITSUBISHI	740, 768	SAAB	1130	SUZUKI	1224
CB5241 OPEL	832, 850	NISSAN	794, 806, 808	VAUXHALL	1330, 1356, 1360, 1372, 1374, 1378	CD5140 CITROËN	216, 232, 234, 272
VAUXHALL	1320, 1352	OPEL	872, 894	CC5502 JAGUAR	556, 558	FORD	432, 438, 440
CB5360 OPEL	834, 852	RENAULT	1030, 1032, 1042, 1044, 1046, 1050, 1056, 1058, 1084, 1088	CC5520 MERCEDES-BENZ	690, 692, 706	MAZDA	634
VAUXHALL	1322, 1354, 1378	CC5100 RENAULT	1026, 1028, 1040, 1044, 1052, 1054, 1056, 1060, 1082, 1084, 1086	CC5550 CHRYSLER	184, 188	MINI	736
CB5370 SEAT	1142	CC5110 RENAULT	1026, 1028, 1040, 1044, 1052, 1054, 1056, 1060, 1082, 1084, 1086	CC5560 CHRYSLER	184, 188	PEUGEOT	936, 938, 946, 960, 976
SKODA	1188, 1194	CC5190 AUDI	66	CC5561 LANCIA	594	RENAULT	1092
VW	1452, 1482, 1500	VW	1496	CC5562 CHRYSLER	186	CD5180 CITROËN	216, 228, 232, 272
CB5371 VW	1512	CC5220 AUDI	72	CC5580 CHRYSLER	184, 190	PEUGEOT	936, 938, 946, 974, 986
CB5400 LAND ROVER	612	SKODA	1190	CC5600 JEEP	562, 568	CD5190 RENAULT	1034, 1048, 1082
ROVER	1106, 1108, 1110, 1112, 1114	VW	1502	CC5601 JEEP	562, 568	FORD	436, 446, 448
CB5420 VOLVO	1408, 1410, 1412, 1426, 1428	CC5221 AUDI	66	CC5602 JEEP	562, 568	MAZDA	636
CB5421 VOLVO	1408, 1410, 1412, 1426, 1428	SEAT	1150, 1160	CC5610 JEEP	564, 566, 568	CD5220 FORD	436, 446, 448
CB5440 VOLVO	1404, 1412, 1414, 1416, 1420, 1432	VW	1448, 1466, 1498, 1524	CC5611 JEEP	564, 566, 568	MAZDA	636
CB5451 VOLVO	1406, 1412, 1418, 1420, 1422, 1430, 1434	CC5222 AUDI	66	CC5612 JEEP	564, 566, 568	CD5221 FORD	436, 440, 446, 448
CB5540 OPEL	836, 838, 870, 884, 886, 894	SEAT	1142, 1170, 1176	CC5613 JEEP	564, 566, 568	CD5230 HONDA	482, 486
VAUXHALL	1326, 1358, 1372	SKODA	1190	CC5620 MERCEDES-BENZ	670, 672, 678, 682, 684, 710, 718, 720	CD5231 HONDA	486
CB5550 MERCEDES-BENZ	666, 718	VW	1502	CC5630 SAAB	1124, 1126, 1128, 1130, 1132	CD5250 NISSAN	782
CB5560 MERCEDES-BENZ	666, 718	CC5223 AUDI	72	CC5661 SMART	1200	CD5260 NISSAN	784, 804, 810, 822
CB5570 MERCEDES-BENZ	666, 718	VW	1500	CC5670 SMART	1200	CD5280 NISSAN	784, 808
CB5610 NISSAN	782	CC5230 AUDI	68, 76, 78, 82	CC5680 FORD	442, 458, 470	CD5300 CITROËN	234, 236, 238, 242, 244, 252, 260, 276
CB5611 NISSAN	784, 786, 792, 808, 812, 818	FORD	442	CC5700 CITROËN	214, 228, 230, 258	FIAT	380, 396
CB5630 NISSAN	784, 786, 806, 816	SEAT	1140, 1142, 1154, 1166, 1172, 1178, 1180	PEUGEOT	924, 934, 986	LANCIA	596
CB5660 BMW	124, 126, 170	SKODA	1186, 1192, 1196	CC5720 CHRYSLER	186	PEUGEOT	936, 946, 958, 962, 968, 972, 980
CB5670 OPEL	842, 858, 874, 882, 888, 890, 892, 896	VW	1458, 1460, 1482, 1484, 1490, 1496, 1498, 1510, 1514, 1530, 1534, 1536, 1538, 1542	CC5750 FORD	446	CD5310 CITROËN	234
SAAB	1132	CC5223 AUDI	72	NISSAN	788, 804, 818	PEUGEOT	956
VAUXHALL	1332, 1336, 1356, 1366, 1370, 1374, 1376, 1380	CC5800 FORD	438	CC5801 FORD	438, 468, 474	CD5330 TOYOTA	1250, 1252, 1258, 1294, 1296, 1298, 1300
CB5671 OPEL	842, 844, 858, 880, 882, 890, 892, 896	CC5860 FORD	432, 438	CC5870 FORD	450	CD5340 TOYOTA	1250, 1276, 1298
SAAB	1132	CC5870 FORD	450	CC5890 FORD	444	CD5350 TOYOTA	1274
VAUXHALL	1332, 1336, 1356, 1370, 1374	CC5900 BMW	134, 136, 140, 148, 156, 160, 172	CC5901 BMW	136, 142, 150, 156, 162, 168, 172, 174	CD5360 TOYOTA	1250
						CD5370 TOYOTA	1250
						CD5380 TOYOTA	1282, 1308, 1310
						CD5381 TOYOTA	1298, 1308, 1310
						CD5400 ISUZU	528
						MAZDA	654
						OPEL	846, 858, 870
						VAUXHALL	1358
						CD5490 CITROËN	236, 238
						FIAT	400
						LANCIA	596
						PEUGEOT	960, 970, 974

							
CD5500	CITROËN 234, 236, 238, 252	CE5050	CITROËN 248, 256	CF474	AUSTIN 104, 106, 108	CG5030	FORD 444
	FIAT 378, 396		PEUGEOT 978		MG 726		SEAT 1142, 1174, 1182
	FORD 438, 442, 468	CE5060	SAAB 1130, 1132		ROVER 1116, 1118		VW 1454, 1484, 1538
	LANCIA 596	CE5110	RENAULT 1024, 1032, 1042, 1048, 1058, 1086, 1092	CF880	FORD 412, 418	CG5090	ISUZU 528
	PEUGEOT 948, 962, 970, 974, 982				LOTUS 630		OPEL 870
	VOLVO 1402, 1410, 1420, 1428, 1430	CE5130	VOLVO 1406, 1408, 1410, 1426	CF5030	LEXUS 618		VAUXHALL 1360
CD5630	SEAT 1144, 1146, 1156	CE5150	VOLVO 1424, 1440	CF5070	HYUNDAI 510, 512	CG5150	MINISUBISHI 766
	VW 1494, 1516	CE5160	VOLVO 1424	CF5430	HYUNDAI 510, 512	CG5270	RENAULT 1034, 1078
CD5640	SEAT 1144, 1146, 1158, 1168	CE5170	VOLVO 1424		KIA 574	CG5290	DAIHATSU 302, 304, 306, 308, 310
	VW 1454, 1496, 1520	CE5171	VOLVO 1424	CF5470	MINISUBISHI 756	CG5350	HONDA 480
CD5650	AUDI 66	CE5180	FIAT 318, 320, 352, 366, 368	CF5481	MINISUBISHI 756, 768	CG5360	HYUNDAI 502
	SEAT 1144, 1148, 1158		LANCIA 602	CF5490	MINISUBISHI 764, 766	CG5370	MAZDA 644, 654
	SKODA 1186	CE5181	FIAT 318, 320, 352, 358, 366, 382	CF5500	MINISUBISHI 750	CG5380	MAZDA 640
	VW 1496, 1522		LANCIA 602, 604	CF5540	NISSAN 810, 822	CG5390	MAZDA 644, 656
CD5690	DAEWOO 294, 298	CE5200	NISSAN 782, 794, 798, 800, 810	CF5541	NISSAN 784, 808, 822	CG5400	MINISUBISHI 768, 770
CD5691	CHEVROLET 178, 180		RENAULT 1026, 1028, 1042, 1054, 1082, 1086	CF5600	NISSAN 802	CG5420	RENAULT 1048, 1058
CD5720	JEEP 566	CE5210	NISSAN 794, 806	CF5690	INFINITI 516	CG5430	SUBARU 1216
	MERCEDES-BENZ 674, 678, 688, 696, 700, 712, 713		OPEL 872		NISSAN 800	CG5440	SUBARU 1210, 1212
CD5760	JEEP 568		RENAULT 1024, 1034, 1048, 1050, 1092	CF5700	INFINITI 516	CG5450	SUBARU 1212
CD5800	FIAT 368		VAUXHALL 1360, 1362		NISSAN 796	CG5460	KIA 574, 576
	LANCIA 594, 604	CE5240	FIAT 332, 360, 382, 386		TOYOTA 1292		MAZDA 646
	OPEL 828, 846, 852, 882	CE5242	FIAT 350, 358, 364, 368, 386	CF5720	INFINITI 516	CG5470	SUZUKI 1222, 1230
	SUZUKI 1224, 1228, 1232	CE5320	FORD 440, 444		NISSAN 796	CG5480	SUZUKI 1220, 1222, 1224, 1228, 1230
	VAUXHALL 1352, 1372	CE5330	DAEWOO 292, 294	CF5740	NISSAN 802, 818	CG5490	TOYOTA 1250
CD5810	FIAT 316, 332, 350, 352, 360, 366, 370		MERCEDES-BENZ 674, 676, 688, 692, 694, 698, 702, 704, 706	CF5760	SUBARU 1216	CG5500	ISUZU 528
	LANCIA 594, 604	CE5331	MERCEDES-BENZ 702	CF5780	TOYOTA 1252, 1254, 1300		OPEL 870
	OPEL 846, 868	CE5370	KIA 574	CF5781	TOYOTA 1248, 1250, 1252, 1282, 1286, 1288, 1296, 1310		VAUXHALL 1358, 1360
CD5820	FIAT 332, 350, 352, 386	CE5331	MERCEDES-BENZ 702	CF5792	TOYOTA 1292	CG5510	SUZUKI 1228, 1232
	LANCIA 594	CE5470	KIA 574	CF5800	TOYOTA 1292	CG5511	SUZUKI 1220, 1222, 1228
	OPEL 832, 852	CE5521	OPEL 838, 848, 856, 870	CF5840	TOYOTA 1254, 1298	CG5520	MINISUBISHI 748, 758, 760, 768, 770
CD5840	ALFA ROMEO 18, 22, 24, 26, 38		VAUXHALL 1328, 1352, 1356	CF5850	LEXUS 618		PROTON 990
	FIAT 324, 328, 384	CE5522	OPEL 838	CF5860	TOYOTA 1292	CG5530	NISSAN 812, 822
	OPEL 840, 880, 888, 896		VAUXHALL 1328, 1336	CF5980	TOYOTA 1282, 1284, 1286, 1288	CG5540	TOYOTA 1290
	SAAB 1130, 1132	CE5523	OPEL 838, 856, 870	CF5990	SEAT 1146, 1156	CG5580	SUBARU 1210, 1212
	VAUXHALL 1332, 1370, 1374, 1378		VAUXHALL 1328, 1356, 1360		SKODA 1186, 1194	CG5581	SUBARU 1210, 1212
CD5910	ALFA ROMEO 24, 30	CE5612	MINISUBISHI 768	CG01A	FIAT 316, 348, 362, 400	CG5590	SUBARU 1210, 1212
	LANCIA 600		VOLVO 1408, 1426		SEAT 1156	CG5600	SUBARU 1214, 1216
CD5960	LANCIA 600	CE5920	OPEL 834, 848, 868	CG210	CARBODIES 176	CG5690	HYUNDAI 510, 512
CD5970	FIAT 322, 332, 356, 360, 382		VAUXHALL 1324, 1336, 1350, 1358		LAND ROVER 610	CG5710	SUZUKI 1230
	LANCIA 592	CE5930	OPEL 834, 868, 894	CG571	JAGUAR 552	CG5730	SUZUKI 1222
CD5980	RENAULT 1026, 1058, 1090		VAUXHALL 1324, 1358, 1378	CG901	TRIUMPH 1312	CG5760	HONDA 496
CD5981	NISSAN 794	CE5950	OPEL 828, 832, 848	CG902	TRIUMPH 1312, 1314	CG5761	HONDA 480
	RENAULT 1026, 1042, 1090		VAUXHALL 1320, 1352	CG913	LAND ROVER 610, 616	CG5780	HONDA 480, 498
CD5991	NISSAN 806	CF24N	ALFA ROMEO 38, 40, 42		ROVER 1120	CG5781	ISUZU 528
	OPEL 894	CF070	AUSTIN 104, 106, 108		TRIUMPH 1314		VAUXHALL 1360
	RENAULT 1030, 1032, 1042, 1044, 1046, 1048, 1056, 1058, 1084, 1086, 1090		MG 732	CG914	LAND ROVER 616	CG5790	HONDA 488
	VAUXHALL 1378		MORRIS 774		LEYLAND / LDV 628	CG5792	HONDA 488, 498
CD9270	LEXUS 618	CF073	AUSTIN 104, 106	CG915	LAND ROVER 612, 616	CG5810	HONDA 498
CE330	TRIUMPH 1312		MG 732		ROVER 1120	CG5811	HONDA 478, 490, 498
CE542	JAGUAR 552	CF463	AUSTIN 104, 108		TRIUMPH 1314	CG5882	INFINITI 516
CE602	ZASTAVA 1554		MG 732	CG5000	VW 1544		NISSAN 784, 790, 800
CE780	MORRIS 774	CF470	AUSTIN 108	CG5010	SEAT 1174, 1182	CG5920	DAIHATSU 308
CE5010	CITROËN 258	CF473	AUSTIN 104, 108		VW 1454, 1484	CG5950	HYUNDAI 504, 508
	PEUGEOT 926		MG 732	CG5020	VW 1454, 1484	CG6040	HYUNDAI 502
						CG6120	MINISUBISHI 764
						CG6130	NISSAN 782, 796, 800

NUMERICAL PARTS LIST









Nummerische Teilenummernliste • Liste des références produits
Lista de referencias









											
CG6150	SUBARU	1210, 1214, 1216	CG8170	MAZDA	634	CG9690	JEEP	568	CK262	MG	732
CG6151	SUBARU	1214	CG8180	SUZUKI	1222, 1224, 1226, 1232	CG9710	RENAULT	1082	CK263	TRIUMPH	1312
CG6220	FIAT	352, 366, 382	CG8190	MAZDA	636, 654	CG9720	CITROËN	268, 270	CK280	TRIUMPH	1312
	LANCIA	594, 604	CG8191	MAZDA	644, 646, 656		PEUGEOT	960, 968	CK302	BEDFORD	112
CG7310	FIAT	352, 382	CG8200	KIA	572, 576		RENAULT	1034, 1048, 1082		VAUXHALL	1378
	LANCIA	594, 604	CG8210	NISSAN	796	CG9740	CITROËN	268, 270	CK525	TRIUMPH	1312
CG7380	FIAT	332, 352	CG8250	KIA	574		PEUGEOT	960, 968	CK663	LEYLAND / LDV	626
	LANCIA	594, 604	CG8260	KIA	572		RENAULT	1034, 1048, 1082		MORRIS	774
CG7390	ALFA ROMEO	26	CG8261	KIA	576	CG9750	CITROËN	238	CK664	MG	732
	FIAT	328, 352, 384	CG8290	HYUNDAI	504, 508, 512		PEUGEOT	960, 962, 970, 974	CK665	MG	732
	OPEL	840, 841, 880, 888, 896	CG8291	HYUNDAI	502	CG9760	RENAULT	1042, 1058, 1084, 1088		MORRIS	774
	VAUXHALL	1332, 1370, 1374, 1378	CG8300	TOYOTA	1304	CG9770	OPEL	882, 892	CN301	ALFA ROMEO	30
CG7410	ALFA ROMEO	26	CG8410	AUDI	78, 84		RENAULT	1034, 1092	CN306	ALFA ROMEO	8, 10, 30, 32, 34, 36, 40
	FIAT	330	CG8420	AUDI	78, 84		SAAB	1134	CN308	ALFA ROMEO	42
CG7480	TOYOTA	1276		VW	1512		VAUXHALL	1370, 1376	CN353	ALFA ROMEO	6, 30, 32, 36
CG7490	TOYOTA	1276, 1298, 1300, 1306	CG8500	MERCEDES-BENZ	666	CG9830	DAIHATSU	302, 304, 306, 308, 310		NISSAN	790
CG7491	TOYOTA	1274, 1276	CG8501	MERCEDES-BENZ	666, 668	CG9870	KIA	576	CN355	ALFA ROMEO	6, 12
CG7520	TOYOTA	1290	CG8790	MERCEDES-BENZ	668, 676, 680, 708	CG9900	KIA	574	CN458	IVECO	534
CG7570	TOYOTA	1304	CG8840	SKODA	1186	CG9910	KIA	572	CV940	FIAT	362, 366, 380, 392, 402
CG7600	MINI	736		VW	1462, 1518	CH831	JAGUAR	552, 554, 556		LANCIA	600, 602
	TOYOTA	1266, 1282, 1304, 1308, 1310	CG8850	AUDI	68	CH832	JAGUAR	552, 554, 556	CX182	ISUZU	520, 522, 526
				SKODA	1190	CH851	FORD	412, 418, 444, 468	CX270	FORD	470
CG7630	LEXUS	618		VW	1462, 1466, 1488, 1504, 1522, 1538	CH854	FORD	412, 444, 468	CX650	TRIUMPH	1312
CG7690	MITSUBISHI	742, 754	CG9000	BMW	140, 142, 152, 154, 156, 162, 168, 170	CH861	FORD	412, 426, 444, 464, 468	CX660	LADA	578, 580
CG7691	MITSUBISHI	768	CG9030	CITROËN	228, 230, 232	CH864	FORD	412, 444, 456, 458, 464, 466, 468	CY070	CITROËN	276, 284
CG7700	MITSUBISHI	740, 762		PEUGEOT	934, 936, 946, 974	CH865	FORD	458, 464, 470		PEUGEOT	944
CG7780	KIA	576	CG9110	TOYOTA	1260, 1270, 1272	CH5010	MERCEDES-BENZ	674, 678, 680, 690, 700, 702	CY080	CITROËN	266, 268, 282
CG7800	SEAT	1182	CG9120	MITSUBISHI	768, 770					PEUGEOT	944, 946, 956
	VW	1452, 1484, 1514	CG9130	MITSUBISHI	746, 750, 762, 770	CH5030	OPEL	828, 832, 848, 850, 852, 854, 868, 882	CY081	CITROËN	246, 254
CG7810	FORD	446, 450	CG9140	TOYOTA	1262		VAUXHALL	1320, 1322, 1350, 1352, 1354, 1356, 1358, 1372		FIAT	338
	NISSAN	782	CG9150	MITSUBISHI	750					PEUGEOT	978
CG7830	KIA	574	CG9170	HONDA	482	CH5031	OPEL	828, 832, 850	CY082	CITROËN	244, 260
CG7840	KIA	574, 576	CG9180	HONDA	482, 494		SUZUKI	1230		FIAT	398
CG7850	MAZDA	652	CG9190	KIA	572		VAUXHALL	1320, 1352	CY090	CITROËN	266, 282
CG7860	ACURA	2	CG9310	CITROËN	224					PEUGEOT	944, 956
	HONDA	496		DAIHATSU	304, 308	CH5040	CITROËN	236, 238	CY130	CITROËN	264, 274, 280
CG7870	ACURA	2		PEUGEOT	928		FIAT	400		PEUGEOT	940, 952, 954, 956
	HONDA	496	CG9540	BMW	120, 134, 138, 142, 144, 152, 160, 162, 168, 172, 174		PEUGEOT	960, 962, 970, 974	CY131	CITROËN	244, 258
CG7880	NISSAN	792, 798		TOYOTA	1252, 1296, 1308, 1310		RENAULT	1024, 1030, 1050, 1088		FIAT	396
CG7890	HONDA	482	CG9560	FORD	436	CH5060	CITROËN	236, 238	CY140	CITROËN	272
CG7900	HONDA	488	CG9570	OPEL	842, 882, 896		FIAT	400	CY200	LAND ROVER	612, 616
CG7910	HYUNDAI	502, 506, 508		VAUXHALL	1332, 1334, 1378, 1380	CJ051	NISSAN	780, 786	CY210	OPEL	834, 854, 884
CG7920	HYUNDAI	504, 510, 512	CG9580	CHEVROLET	178, 180					VAUXHALL	1322, 1324, 1354, 1372
	KIA	572, 576		OPEL	844, 882, 890, 896	CJ127	MAZDA	648	CY211	OPEL	834, 848
CG7960	HONDA	494		VAUXHALL	1334, 1376, 1378, 1380	CJ232	MAZDA	654		VAUXHALL	1322
CG7970	DAIHATSU	304, 306	CG9590	CHEVROLET	180	CJ290	TOYOTA	1286	CY220	OPEL	856, 884
CG7980	SUBARU	1216		OPEL	880, 892, 896	CJ292	TOYOTA	1286		VAUXHALL	1354, 1372
CG7990	DAEWOO	290, 294		VAUXHALL	1370, 1376, 1380	CJ491	NISSAN	780	CY221	OPEL	836, 886
CG8000	DAEWOO	290, 292, 296	CG9600	AUDI	70, 78	CJ586	NISSAN	780, 788, 794, 796		VAUXHALL	1328, 1372
CG8010	HONDA	498		VW	1484, 1538	CJ631	MAZDA	638, 650, 652, 656	CY250	NISSAN	780, 796, 808, 818
CG8020	SUZUKI	1220, 1222, 1228, 1230	CG9610	AUDI	72, 100	CJ633	MAZDA	638, 650, 652, 656	CY260	VOLVO	1402, 1424, 1438
CG8030	HYUNDAI	504		VW	1462, 1486, 1498, 1516, 1538, 1546	CJ652	MAZDA	638	CY270	BMW	128
CG8060	HYUNDAI	502, 506	CG9620	VW	1452, 1484, 1500	CJ690	MITSUBISHI	744	CY320	FIAT	326
CG8080	MITSUBISHI	740, 754, 766, 768	CG9621	VW	1514	CJ911	DAIHATSU	310		LANCIA	590
CG8090	HYUNDAI	514	CG9660	CHRYSLER	190	CJ960	TOYOTA	1278	CY470	FIAT	318, 322, 354, 358, 360
CG8100	SUZUKI	1224				CJ962	TOYOTA	1262, 1278		LANCIA	584, 588, 592
CG8130	HONDA	490				CK260	TRIUMPH	1312			
CG8140	KIA	572				CK261	TRIUMPH	1312			
CG8150	MAZDA	658									

							
CY520	ALFA ROMEO 24, 30 FIAT 356 LANCIA 590, 594	DC921	BMW 122, 144	DF572	PEUGEOT 938	DH890	FORD 444, 458, 460 LEYLAND / LDV 622, 624 PEUGEOT 964, 984 SSANGYONG 1204
CY550	ALFA ROMEO 14, 16, 22 FIAT 320, 322, 354, 358 LANCIA 592 SAAB 1130	DC929	BMW 122, 124, 144	DF580	PEUGEOT 962, 984	DJ021	JAGUAR 552
CY610	ALFA ROMEO 28	DC935	BMW 148, 154, 158, 160	DF731	RENAULT 1062	DJ022	JAGUAR 552, 554
CY611	ALFA ROMEO 28	DC993	TOYOTA 1256	DF871	RENAULT 1040, 1068	DJ023	JAGUAR 552, 554
CY620	ALFA ROMEO 24, 30	DC994	TOYOTA 1256	DF873	RENAULT 1068, 1088	DJ024	JAGUAR 552
CY640	ALFA ROMEO 18, 24, 30, 38, 40, 44 LANCIA 600 MAZDA 642	DD010	DAIHATSU 744	DG050	FORD 466 PEUGEOT 962, 964, 984	DJ172	OPEL 870, 878 VAUXHALL 1368
CY680	CITROËN 248 FIAT 344 IVECO 536, 538, 546 PEUGEOT 978	DD042	DAIHATSU 740, 746	DG052	FORD 460 LEYLAND / LDV 622, 624 PEUGEOT 964, 966 TALBOT 1242	DJ202	FORD 412, 418
CY811	ISUZU 524, 526, 528 MAZDA 642 OPEL 840, 848, 854, 856, 862, 866 VAUXHALL 1324, 1330, 1338, 1348, 1352, 1354, 1356, 1364, 1366, 1374	DD061	TOYOTA 1260	DG170	JEEP 564 RENAULT 1040, 1070	DJ353	NISSAN 802
CY930	VW 1520	DD070	VOLVO 1388	DG171	PEUGEOT 964	DJ360	NISSAN 802
CY940	VW 1468, 1502, 1546	DD072	VOLVO 1384, 1386, 1388, 1394	DG173	JEEP 564, 568 RENAULT 1032, 1034, 1050, 1070, 1074, 1076, 1078, 1088, 1090	DJ363	NISSAN 802
CY941	SEAT 1150, 1162, 1176 VW 1468, 1470, 1502, 1524, 1546	DD073	VOLVO 1384, 1386, 1388, 1392, 1398	DG452	CITROËN 230, 240 PEUGEOT 984	DJ420	MAZDA 638
CY942	AUDI 72 VW 1502	DD363	ISUZU 524	DG542	CITROËN 232 FIAT 316	DJ430	MAZDA 638, 640, 652
CY960	AUDI 54, 56, 62, 64, 86, 96, 98	DD501	AUDI 50 VW 1456, 1468, 1488, 1504, 1540	DG690	TOYOTA 1306	DJ431	MAZDA 638, 640, 652
CY970	AUDI 72, 74, 76, 82, 90 VW 1506	DD502	AUDI 50, 56 VW 1470, 1486, 1490, 1504, 1540	DG724	NISSAN 788, 794, 802, 820	DJ432	MAZDA 638, 652
CY971	AUDI 68, 74, 76, 82, 100 SEAT 1140, 1152, 1164, 1172, 1176 SKODA 1190, 1196 VW 1448, 1476, 1498, 1508, 1528, 1534	DD620	AUDI 64	DG725	NISSAN 802, 820	DJ440	FORD 414, 416, 428, 430, 450
CY980	AUDI 66 SEAT 1150, 1160, 1170, 1176 VW 1448, 1466, 1524	DD621	AUDI 64 VW 1532	DG811	FIAT 372, 376	DJ442	FORD 416, 430, 452
DC92B	BMW 124, 144	DD622	AUDI 64, 98	DG871	VW 1486, 1500	DJ444	FORD 416, 418, 430, 452
DC240	FORD 414, 426, 450	DE070	MITSUBISHI 742	DH060	NISSAN 794	DJ445	FORD 462
DC260	TOYOTA 1290	DE360	MAZDA 652	DH061	MITSUBISHI 766, 770	DJ600	MITSUBISHI 744, 746, 752, 754, 762, 766
DC264	TOYOTA 1290	DE392	TOYOTA 1282	DH062	MITSUBISHI 744, 748, 770, 772	DJ601	MITSUBISHI 752, 762
DC265	TOYOTA 1290	DE545	FORD 412	DH064	MITSUBISHI 748, 752, 770	DJ610	HONDA 482
DC271	NISSAN 784, 814	DE550	SUZUKI 1222, 1224	DH080	JEEP 562, 564 RENAULT 1032, 1034, 1040, 1050, 1070, 1076, 1078, 1082, 1090	DJ650	ISUZU 520, 522, 526
DC372	ALFA ROMEO 8, 32, 42	DE588	ALFA ROMEO 34, 36 FIAT 318, 324, 330, 340, 356 IVECO 534, 536, 538, 540, 544, 546 OPEL 828, 872 RENAULT 1050, 1052, 1090 VAUXHALL 1320, 1362	DH066	MITSUBISHI 748, 752, 770	DJ652	ISUZU 520, 522, 526
DC373	ALFA ROMEO 8, 10, 30, 32, 34, 36, 40	DE622	ALFA ROMEO 6, 32, 36 NISSAN 790	DH681	RENAULT 1060, 1062, 1064, 1080	DJ654	ISUZU 520, 522, 526
DC380	NISSAN 800	DE623	ALFA ROMEO 6, 12	DH683	RENAULT 1024, 1034, 1036, 1038, 1062, 1064, 1066, 1078	DJ720	CITROËN 216, 218, 222, 224, 226, 230, 240, 242, 244, 246, 250, 252, 254, 260, 264, 266, 272, 274, 276, 280, 282 FIAT 334, 336, 338, 378, 396 HONDA 490 HYUNDAI 508 LADA 578 LEYLAND / LDV 622, 624 PEUGEOT 932, 934, 940, 942, 944, 950, 952, 954, 956, 958, 970, 976, 980, 982, 986, 988 ROVER 1106, 1110 SUZUKI 1220, 1226, 1230 TALBOT 1238
DC386	NISSAN 790	DE865	DAIHATSU 306	DH685	RENAULT 1060, 1062, 1064, 1080	DJ740	TOYOTA 1264, 1290
DC388	NISSAN 792, 796, 800	DE880	JAGUAR 552, 554, 556	DH686	DACIA 286 RENAULT 1068	DJ741	TOYOTA 1282, 1290
DC635	TRIUMPH 1312	DF050	CITROËN 212, 244, 254	DH687	RENAULT 1024, 1034, 1036, 1038, 1062, 1064, 1066, 1078	DJ742	TOYOTA 1264, 1290
DC636	TRIUMPH 1312	DF106	CITROËN 224, 226 PEUGEOT 928, 930, 948 TALBOT 1236, 1238, 1240, 1242	DH690	RENAULT 1040, 1064, 1088	DJ851	FIAT 350, 372, 374, 386, 402 LANCIA 596
DC790	MERCEDES-BENZ 664, 686, 696, 714, 716, 718	DF107	CITROËN 224, 226 PEUGEOT 928, 930, 948 TALBOT 1236, 1238, 1240, 1242	DH693	RENAULT 1036, 1038, 1062, 1066, 1070, 1074, 1078	DJ852	FIAT 374, 386, 402 ZASTAVA 1554
DC800	MERCEDES-BENZ 688, 696, 714, 716	DF180	PEUGEOT 954	DH696	VOLVO 1384, 1386	DJ872	FIAT 316, 348, 364, 366, 402, 404
DC820	MERCEDES-BENZ 686	DF351	RENAULT 1060	DH697	VOLVO 1384	DJ891	MITSUBISHI 752
		DF490	CITROËN 214	DH699	RENAULT 1036, 1038, 1066, 1070, 1074, 1078	DJ898	MITSUBISHI 762, 766
				DH700	LADA 578, 580	DK020	OPEL 878
				DH740	SUZUKI 1220, 1222	DK047	ISUZU 522
				DH855	ALFA ROMEO 8		
				DH860	OPEL 868 VAUXHALL 1320, 1362		
				DH870	MERCEDES-BENZ 664, 680, 682		
				DH872	MERCEDES-BENZ 682		
				DH873	MERCEDES-BENZ 664, 682		
				DH876	MERCEDES-BENZ 664, 682		
				DH882	MERCEDES-BENZ 664, 684, 714		

NUMERICAL PARTS LIST









Numerische Teilenummernliste • Liste des références produits
Lista de referencias









							
DK100 HONDA	496, 498	DL010 BEDFORD	110	DL831 CITROËN	230, 240	DM533 CITROËN	230
DK103 HONDA	498	OPEL	830, 864	PEUGEOT	984	FIAT	338
DK410 MITSUBISHI	746	VAUXHALL	1326, 1338, 1346	DL880 MAZDA	652	PEUGEOT	962, 964, 966, 982, 984
DK412 MITSUBISHI	742, 744, 746, 748, 752	DL011 BEDFORD	110, 112	DL910 RENAULT	1028, 1064, 1066, 1068, 1072, 1074, 1088	DM570 NISSAN	780, 790, 792, 796, 812
DK420 MITSUBISHI	744	OPEL	830, 838, 864, 886	VOLVO	1386, 1388, 1390, 1392	DM574 NISSAN	780, 782, 790, 792, 812
DK440 NISSAN	790, 810, 814, 816	VAUXHALL	1326, 1328, 1336, 1338, 1346	DL911 RENAULT	1028, 1064, 1066, 1068, 1072, 1088	DM577 NISSAN	790, 792, 800, 820
DK441 NISSAN	790, 810, 814	DL012 OPEL	840	VOLVO	1386, 1388, 1390	DM580 NISSAN	788, 802, 804, 820
DK445 NISSAN	792, 806, 814, 816	VAUXHALL	1330, 1336	DL916 VOLVO	1390, 1392	DM581 NISSAN	788, 802, 804, 820
DK446 NISSAN	810, 816	DL081 FORD	466	DL950 TOYOTA	1284, 1288	DM590 NISSAN	812
DK447 NISSAN	814	DL280 SUBARU	1216	DL951 TOYOTA	1280, 1288	DM593 NISSAN	786
DK449 NISSAN	810, 816	DL300 TOYOTA	1258, 1272, 1276, 1292	DL961 MITSUBISHI	740	DM597 NISSAN	786, 812
DK450 AUSTIN	104, 106, 108	DL310 NISSAN	812, 822	OPEL	828	DM598 NISSAN	806
MG	726	DL321 KIA	576	RENAULT	1030, 1036, 1038, 1040, 1044, 1056, 1064, 1066, 1068, 1072, 1074, 1080, 1088	DM631 VOLVO	1384, 1394, 1396, 1400
ROVER	1116, 1118	MAZDA	646, 648, 652	VAUXHALL	1320	DM660 VOLVO	1396, 1400
DK451 AUSTIN	106	DL340 DAIHATSU	304	VOLVO	1386, 1388	VW	1492, 1494
MG	726	TOYOTA	1268, 1278, 1302	DM300 MAZDA	644	DM690 VW	1540, 1542
DK461 TOYOTA	1264, 1278, 1280, 1302	DL341 DAIHATSU	304	DM330 BEDFORD	112	DM700 VW	1492
DK470 BEDFORD	110	TOYOTA	1268, 1278, 1302	ISUZU	530	DM710 FIAT	334
OPEL	828, 830, 852, 860, 868	DL350 TOYOTA	1254, 1260, 1264, 1276, 1278, 1280	AUDI	50, 52, 58, 94	PEUGEOT	962, 964, 984
VAUXHALL	1322, 1344, 1364	DL361 HONDA	478, 496	VW	1500, 1502, 1506	DM740 SUZUKI	1224, 1226
DK471 BEDFORD	110	DL381 AUSTIN	108	DM361 AUDI	50, 58, 94	DM750 MITSUBISHI	740, 746, 750
OPEL	828, 830, 852, 860, 862	ROVER	1104	VW	1506	DM761 NISSAN	786
VAUXHALL	1322, 1336, 1344, 1362, 1364	DL382 ROVER	1104	DM363 AUDI	50, 52, 94	DM762 NISSAN	806
DK480 OPEL	830, 862, 864	DL390 SUZUKI	1226	VW	1506	DM765 NISSAN	786, 806
VAUXHALL	1328, 1338, 1346	DL391 BEDFORD	114	DM365 SEAT	1152, 1164, 1176	DM766 NISSAN	788, 814
DK502 ISUZU	520, 522, 526	DL401 FORD	412, 460, 466	VW	1506	DM769 NISSAN	794
DK541 FIAT	316, 376	DL402 FORD	460, 466	DM366 SEAT	1152, 1162, 1178	DM821 NISSAN	784, 788
DK570 ALFA ROMEO	10, 12, 20, 28, 34, 38	DL450 HYUNDAI	510	VW	1460, 1474, 1490, 1508, 1534	DM830 MITSUBISHI	740, 746, 748, 766, 770, 772
CHRYSLER	184, 190	DL452 MITSUBISHI	744, 770, 772	DM367 SEAT	1152, 1162, 1178	DM831 MITSUBISHI	744, 746, 748, 758, 770
FORD	460	DL491 AUDI	60	AUDI	50	DM840 AUDI	56, 58, 62, 64, 94, 96
JEEP	562	DL550 OPEL	850, 860	SEAT	1152, 1162, 1178	VW	1512, 1514
LAND ROVER	614	VAUXHALL	1362	VW	1466, 1472, 1474, 1488, 1506, 1508, 1548	DM850 CARBODIES	176
OPEL	858	DL551 OPEL	850	DM370 BEDFORD	112	LAND ROVER	610
ROVER	1116, 1120	VAUXHALL	1362, 1364	ISUZU	520, 528	LEYLAND / LDV	628
VAUXHALL	1358	DL561 VW	1518	DM368 SEAT	1150, 1160, 1168, 1176, 1178	DM852 AUSTIN	106
DK572 ALFA ROMEO	6	DL570 VW	1464, 1486, 1518	VW	1456, 1458, 1466, 1470, 1474, 1476, 1488, 1490, 1500, 1506, 1508, 1524, 1532, 1534	LAND ROVER	610
TOYOTA	1288	DL571 VW	1464	DM373 SEAT	1148, 1156, 1158	DM871 TOYOTA	1266, 1278, 1302, 1306
DK573 ALFA ROMEO	20	DL572 SEAT	1156, 1158	DM377 SEAT	1148, 1158	DM881 TOYOTA	1264, 1278, 1286, 1288, 1298
CHRYSLER	184, 190	VW	1464, 1486, 1516, 1518, 1546	VW	1464, 1486, 1516, 1518, 1546	VW	1538
JEEP	562, 564, 566	DL573 SEAT	1148, 1156, 1158	DM380 OPEL	868, 878	DM883 TOYOTA	1248, 1288, 1298
DK610 SAAB	1124	VW	1464, 1516, 1546	VAUXHALL	1342	DM900 DAIHATSU	308
DK611 SAAB	1124	DL574 SEAT	1148, 1158	DM381 OPEL	830, 866, 878	DM901 DAIHATSU	308, 310
DK612 SAAB	1124	VW	1464, 1486, 1516, 1518, 1546	VAUXHALL	1340	DM902 DAIHATSU	308
DK640 VOLVO	1384	DL611 TALBOT	1236, 1238, 1242	SSANGYONG	1204	DM910 SUZUKI	1220
DK642 VOLVO	1384, 1394	DL650 CITROËN	222, 262	VAUXHALL	1340	DM911 SUZUKI	1220
DK643 VOLVO	1384, 1394, 1396, 1400	DL651 CITROËN	216, 264, 274	DM380 OPEL	868, 878	DM912 SUZUKI	1220
DK644 VOLVO	1394, 1398	DL681 BMW	136, 148, 150, 170	VAUXHALL	1342	DM920 HONDA	496
DK670 TOYOTA	1252, 1258, 1260, 1264, 1276, 1278, 1308	DL690 BMW	156, 160, 162	DM381 OPEL	830, 866, 878	DM921 HONDA	478, 496
DK680 TOYOTA	1262, 1264, 1276, 1278, 1280, 1302	DL691 BMW	156, 160, 164	VAUXHALL	1330, 1340, 1348	DM940 AUDI	62
DK700 TOYOTA	1262	DL742 TOYOTA	1256	DM450 DAIHATSU	304	FORD	416, 432, 452
DK701 TOYOTA	1262	DL761 NISSAN	798	DM491 ISUZU	520, 524, 526, 528	DM992 HONDA	482, 484, 492
DK750 NISSAN	820	DL770 NISSAN	788, 792, 802	DM530 CITROËN	230	DM993 HONDA	482, 484, 494
DK831 NISSAN	814	DL820 DAIHATSU	306, 308	FIAT	338	DM995 HONDA	482, 484, 494, 498
DK840 NISSAN	814	TOYOTA	1280, 1282, 1284, 1286, 1292, 1294, 1302	PEUGEOT	962, 964, 966, 982, 984	ROVER	1102
DK930 TOYOTA	1290					DN010 OPEL	850
DK940 TOYOTA	1290					VAUXHALL	1362

											
DN041	OPEL	850, 860, 868	DN622	MAZDA	646, 650, 656	DP740	HONDA	496	DR073	FIAT	340, 342
	VAUXHALL	1320, 1362	DN640	DAIHATSU	306, 308	DP790	FORD	414, 428		IVECO	546, 548
DN042	OPEL	860		TOYOTA	1280, 1282, 1284, 1286, 1294	DP800	BEDFORD	110	DR100	FIAT	404
	VAUXHALL	1320	DN671	AUSTIN	104, 108		DAEWOO	290	DR130	LANCIA	586
DN140	FORD	462		MG	726, 734		OPEL	830, 864, 884	DR140	DAIHATSU	304, 306
DN150	FORD	458, 462		ROVER	1112	DP802	VAUXHALL	1324, 1338, 1346	DR160	NISSAN	798
DN170	NISSAN	790	DN672	LEYLAND / LDV	622, 626		OPEL	830, 836, 856, 864, 884, 886	DR161	NISSAN	798
DN190	BEDFORD	112	DN676	AUSTIN	104, 108		VAUXHALL	1326, 1328, 1336, 1346, 1364	DR190	BEDFORD	112
	ISUZU	522		MG	726, 734	DP803	OPEL	836, 856		ISUZU	520, 526, 528
DN200	TOYOTA	1266, 1302, 1304	DN684	RENAULT	1024, 1034, 1036, 1038, 1062, 1064, 1066, 1070, 1074, 1078		VAUXHALL	1326, 1364	DR200	NISSAN	810, 816
DN220	DAIHATSU	744, 758, 760		MERCEDES-BENZ	666, 686, 696	DP806	OPEL	836, 838, 886	DR250	TOYOTA	1252, 1258, 1294, 1296
DN221	DAIHATSU	748, 766, 770	DN722	MERCEDES-BENZ	666, 686, 696		VAUXHALL	1324, 1336, 1372	DR270	TOYOTA	1268, 1292
DN230	DAIHATSU	742, 756, 760	DN723	MERCEDES-BENZ	666, 686, 696	DP810	DAEWOO	290, 296	DR290	LAND ROVER	612, 616
	PROTON	990	DP011	FIAT	316, 348, 362, 400		OPEL	830, 866, 872, 886, 888	DR300	TOYOTA	1264, 1280, 1304
DN231	DAIHATSU	742, 756, 760	DP014	FIAT	316		VAUXHALL	1330, 1342, 1348	DR301	TOYOTA	1264, 1280, 1304
DN233	DAIHATSU	742, 756, 760	DP022	FIAT	362, 364	DP811	OPEL	864, 872	DR330	TOYOTA	1260, 1262, 1296
	PROTON	990	DP051	FIAT	316, 362		VAUXHALL	1330, 1338, 1340, 1342, 1348	DR332	TOYOTA	1262, 1296
DN240	HONDA	482	DP060	FIAT	348	DP820	DAEWOO	290	DR360	NISSAN	786, 812, 820, 822
DN250	DAIHATSU	304, 306	DP068A	FIAT	372		OPEL	832, 844, 858, 866, 872, 874, 888, 890	DR422	BMW	136, 148
DN330	DAIHATSU	742, 754, 760	DP070	ZASTAVA	1554		VAUXHALL	1332, 1334, 1340, 1342, 1344, 1348, 1356, 1366	DR480	FIAT	316
	PROTON	990	DP110	FIAT	374	DP840	MAZDA	656	DR510	CITROËN	224
DN332	DAIHATSU	742, 754, 756, 760		ZASTAVA	1554		FIAT	372, 374, 404		PEUGEOT	952, 954
DN360	RENAULT	1062, 1064, 1066	DP133	FIAT	376	DP860	FIAT	372, 374, 404	DR540	HONDA	482, 484, 492
DN361	RENAULT	1062, 1064, 1066	DP190	FIAT	324	DP861	FIAT	350, 372, 374	DR541	HONDA	486, 490, 492
DN390	TOYOTA	1256, 1260, 1268, 1270, 1276, 1292, 1294, 1302, 1304, 1308	DP273	FIAT	330		LANCIA	596	DR560	SUBARU	1212, 1216
				LANCIA	598	DP870	FIAT	372, 374	DR561	SUBARU	1212, 1214, 1216
DN392	TOYOTA	1256, 1260, 1268, 1270, 1276, 1294	DP286	FIAT	364, 380		NISSAN	814	DR570	TOYOTA	1290
DN450	HONDA	478, 498	DP289	FIAT	364, 380	DP871	FIAT	372, 374, 402	DR580	TOYOTA	1254, 1308
DN451	HONDA	478, 496	DP292	LANCIA	602		LANCIA	596	DR581	TOYOTA	1258, 1274, 1276, 1292, 1306
DN470	FORD	418	DP293	FIAT	346, 348, 402	DP880	LEYLAND / LDV	624	DR600	CHRYSLER	184, 186, 190
DN471	FORD	418	DP294	FIAT	402		ROVER	1118		MITSUBISHI	764
DN472	FORD	430	DP301	FIAT	404, 406	DP881	ROVER	1118	DR601	MITSUBISHI	744, 746, 750, 764, 766
DN480	SUZUKI	1226	DP530	TOYOTA	1256, 1268	DP882	LEYLAND / LDV	624	DR610	FIAT	316, 348, 362, 400
DN481	SUZUKI	1222, 1224, 1226, 1228	DP531	TOYOTA	1268		ROVER	1118		SEAT	1156
DN482	SUZUKI	1222, 1228	DP540	MAZDA	640	DP883	ROVER	1118	DR611	FIAT	362
DN483	SUZUKI	1226	DP560	DAIHATSU	306, 308	DP920	BEDFORD	112	DR620	FIAT	350, 360, 382, 388, 392, 404
DN484	SUZUKI	1228	DP561	DAIHATSU	306, 308		ISUZU	520, 528		ZASTAVA	1554
DN530	TOYOTA	1304	DP564	DAIHATSU	306, 308		OPEL	846	DR630	CITROËN	240, 250
DN550	SUBARU	1214	DP565	DAIHATSU	308		VAUXHALL	1340		FIAT	350, 366, 376, 388, 392
DN551	SUBARU	1214	DP570	MAZDA	642	DP950	NISSAN	814		LANCIA	584
DN552	SUBARU	1214	DP571	MAZDA	642	DP951	NISSAN	782		PEUGEOT	978
DN560	SUBARU	1210, 1214, 1216	DP580	NISSAN	792, 794, 810, 818	DP960	NISSAN	780, 806, 812, 816, 820	DR631	FIAT	366, 368, 390
DN561	SUBARU	1210, 1214, 1216	DP581	NISSAN	792, 810, 818	DP970	NISSAN	780, 806, 810, 816	DR632	FIAT	366, 376
DN571	CITROËN	220, 224, 254, 262	DP600	MAZDA	642	DP980	BEDFORD	112		LANCIA	584, 588
	PEUGEOT	922, 928	DP601	MAZDA	642		ISUZU	520	DR650	HONDA	494
	TALBOT	1240	DP602	KIA	574, 576		VAUXHALL	1360		ROVER	1116
DN582	CITROËN	220, 226, 262		MAZDA	640	DP990	ALFA ROMEO	8	DR660	NISSAN	804, 818
	PEUGEOT	924, 930	DP630	HONDA	486, 492, 494, 498	DR010	OPEL	874, 876, 878, 880	DR662	NISSAN	800, 802
	TALBOT	1240	DP650	TOYOTA	1248, 1280, 1284, 1286, 1304		VAUXHALL	1344	DR670	DAIHATSU	302
DN590	CITROËN	220, 222, 262, 280, 282	DP651	TOYOTA	1294, 1306	DR012	BEDFORD	112	DR730	MAZDA	646, 648
	PEUGEOT	932, 934, 938, 940, 950, 952, 954	DP660	FIAT	362		OPEL	878	DR731	MAZDA	650
DN600	LAND ROVER	610	DP688	FIAT	328		VAUXHALL	1344, 1368	DR732	MAZDA	648, 656
DN610	ISUZU	522, 524	DP689	FIAT	388, 392	DR013	OPEL	876, 878, 880	DR734	MAZDA	648, 656
DN620	MAZDA	652	DP730	SUBARU	1212, 1214		VAUXHALL	1344	DR736	MAZDA	644
DN621	KIA	572, 576	DP731	SUBARU	1212, 1214	DR040	ALFA ROMEO	8	DR750	TOYOTA	1256, 1268, 1294
	MAZDA	650, 652									

NUMERICAL PARTS LIST









Numerische Teilenummernliste • Liste des références produits
Lista de referencias









											
DR751	TOYOTA	1256, 1260, 1268, 1270, 1294	DS570	FIAT	362	DT110	FORD	426	DT630	TOYOTA	1264, 1276, 1278, 1280
DR760	DAIHATSU	302	DS580	RENAULT	1026, 1070	DT130	TOYOTA	1278, 1280, 1288	DT660	AUDI	56, 64, 80, 88, 90, 92, 98
DR830	BMW	122, 124, 144	DS600	SUZUKI	1222, 1228	DT140	FORD	414, 428, 450	DT680	BMW	130, 146
DR831	BMW	122, 124, 126, 144, 170	DS610	NISSAN	816	DT193	FORD	420, 422, 424, 434, 436, 448, 454, 456, 464	DT681	BMW	130, 146
DR850	KIA	574, 576	DS612	NISSAN	810		MAZDA	638	DT691	BMW	136, 148, 150
	MAZDA	646, 648, 652	DS620	LADA	578, 580	DT260	FIAT	326, 362, 380	DT692	BMW	134, 140, 148, 156, 160, 172
DR880	DAIHATSU	302, 308	DS700	HONDA	478, 480, 496	DT270	FIAT	324	DT693	BMW	134, 140, 150
DR881	DAIHATSU	302, 308, 310		ROVER	1112	DT290	FIAT	374, 376, 406	DT752	LANCIA	598, 600
DR882	DAIHATSU	302	DS705	HONDA	478, 480, 498		LANCIA	588, 596		RENAULT	1082
DR883	DAIHATSU	302, 308, 310		LADA	578	DT300	FIAT	328	DT800	FORD	470, 472
DR890	TOYOTA	1252, 1264, 1290		OPEL	842, 844, 866, 888, 890	DT340	ALFA ROMEO	6, 12, 14	DT801	FORD	472
DR900	TOYOTA	1270, 1294, 1302	DS731	VAUXHALL	1334, 1340, 1350	DT350	ALFA ROMEO	8, 26, 42		LEYLAND / LDV	624
DR901	TOYOTA	1256, 1270, 1302		CITROËN	214, 278	DT360	ALFA ROMEO	8, 36	DT802	FORD	472
DR940	ISUZU	520, 528		PEUGEOT	926	DT370	ALFA ROMEO	26		LEYLAND / LDV	624
DR951	TOYOTA	1282, 1308	DS760	ROVER	1102	DT380	ALFA ROMEO	28	DT803	FORD	472
DR960	MAZDA	640	DS770	NISSAN	788, 802, 820	DT400	FIAT	404	DT805	FORD	472
DR961	MAZDA	636, 638, 640	DS771	NISSAN	780, 784, 792, 812	DT401	FIAT	368		LEYLAND / LDV	624
DR990	ISUZU	520, 522		FORD	446	DT410	FIAT	328	DT806	FORD	472
	OPEL	846	DS791	NISSAN	780, 784, 792, 804, 806, 812, 818		LANCIA	584		LEYLAND / LDV	624
	VAUXHALL	1340		ROVER	1114	DT411	LANCIA	586, 596	DT811	VW	1512
DR991	ISUZU	520, 522	DS792	LAND ROVER	612	DT412	FIAT	394	DT812	VW	1462, 1512
DS050	NISSAN	814, 818		ROVER	1106, 1110, 1114		LANCIA	598	DT813	AUDI	52, 54, 96
DS051	NISSAN	818	DS793	ROVER	1106, 1114	DT413	FIAT	328, 330	DT814	AUDI	52, 54, 60, 92, 96
DS060	TOYOTA	1262	DS795	ROVER	1106, 1110, 1114		LANCIA	598	DT815	AUDI	60, 84
DS061	TOYOTA	1296	DS797	ROVER	1106, 1110, 1114	DT420	ALFA ROMEO	26	DT816	SEAT	1154, 1166, 1180
DS070	MAZDA	642, 654	DS810	CITROËN	212		FIAT	328, 330		VW	1462, 1484, 1512, 1550
DS111	HONDA	478, 496		PEUGEOT	924, 928	DT423	LANCIA	598	DT819	VW	1462, 1476, 1508
DS120	HYUNDAI	510	DS820	CITROËN	248, 268		LANCIA	586, 590	DT820	AUDI	54, 56, 62, 66, 86, 92, 98
	DAEWOO	292		FIAT	338	DT430	HYUNDAI	504, 508, 510	DT880	MITSUBISHI	750, 754
	MITSUBISHI	746, 748, 750	DS860	PEUGEOT	966		MITSUBISHI	742, 754, 756, 760	DT890	MITSUBISHI	740, 742, 744, 748, 756, 758, 768
DS130	HYUNDAI	506, 508, 512		PEUGEOT	966	DT431	MITSUBISHI	756, 760		PROTON	990
	KIA	574	DS862	ROVER	1108, 1112, 1114	DT440	FIAT	390, 394, 396	DT900	SUZUKI	1220, 1224, 1226
	MITSUBISHI	746, 750, 752, 754, 762, 766, 768	DS870	TOYOTA	1298		LANCIA	586	DV010	MITSUBISHI	740
DS200	NISSAN	788, 804, 818, 820	DS881	HONDA	488, 490, 492	DT441	FIAT	328, 394	DV020	HONDA	486, 488, 492
DS240	HYUNDAI	508		ROVER	1104, 1108		LANCIA	598	DV021	HONDA	496
	MITSUBISHI	742, 744, 758, 760	DS910	NISSAN	782	DT442	LANCIA	598	DV022	HONDA	488
DS241	HYUNDAI	508	DS940	MAZDA	654, 656	DT445	FIAT	328	DV030	HONDA	480, 498
	MITSUBISHI	742, 758, 760	DS950	MAZDA	642, 644	DT446	FIAT	348, 388, 392, 394		ROVER	1112
DS260	OPEL	832, 834, 848, 854, 862, 884	DS970	TOYOTA	1254, 1262, 1296		LANCIA	586	DV041	HONDA	486, 488, 490, 492
	VAUXHALL	1322, 1324, 1334, 1338, 1346, 1350, 1354, 1355, 1364	DT010	CITROËN	212, 214, 218, 220, 226, 258, 278, 280	DT447	ALFA ROMEO	20	DV050	HONDA	492
	DAEWOO	292		PEUGEOT	924, 926, 928, 930, 940, 948, 952, 986		FIAT	326	DV090	ACURA	2
	OPEL	832, 834, 848, 854, 862	DT012	CITROËN	212, 214, 216, 218, 220, 226, 228, 230, 256, 258, 270, 278, 280	DT448	LANCIA	590		HONDA	494
	VAUXHALL	1322, 1350, 1354, 1355, 1364		PEUGEOT	924, 926, 928, 930, 934, 940, 946, 948, 952, 974, 976, 984, 986		LANCIA	586, 588, 590, 596	DV110	KIA	574
DS280	MAZDA	650, 654	DT013	CITROËN	212	DT449	FIAT	390, 394, 396		MAZDA	642, 654, 656
DS292	LEXUS	618		PEUGEOT	928		LANCIA	584, 586, 588	DV150	CITROËN	246, 260, 268, 270
	TOYOTA	1254	DT050	NISSAN	812	DT482	FORD	458, 466		FIAT	400
DS360	TOYOTA	1248, 1288, 1298, 1306	DT051	NISSAN	812	DT500	FORD	458		LANCIA	606
DS381	ALFA ROMEO	34, 36	DT070	JAGUAR	552, 554, 556	DT510	FORD	462, 466, 472	DV190	RENAULT	1024, 1036, 1038, 1078, 1090
	FIAT	340, 342, 344	DT071	JAGUAR	552, 554, 556	DT540	MERCEDES-BENZ	664, 670, 680, 682	DV250	NISSAN	790, 802
	IVECO	534, 536, 538, 540, 542, 544, 546	DT072	JAGUAR	552, 556	DT561	SAAB	1124, 1126, 1128	DV311	NISSAN	780, 784, 790, 792, 796, 800, 802, 820
	RENAULT	1052	DT81B	SEAT	1156, 1166, 1182	DT562	SAAB	1128, 1130	DV330	TOYOTA	1268, 1296, 1306
DS430	DAIHATSU	302		VW	1484, 1512	DT580	SKODA	1188	DV331	TOYOTA	1266, 1282, 1304
DS431	DAIHATSU	306, 310	DT81C	AUDI	52, 54, 92, 96	DT590	VW	1540	DV340	HONDA	498
DS432	DAIHATSU	302									

												
DV350	HONDA	486	DW301	ALFA ROMEO	20	DW757	LAND ROVER	614	DX652	RENAULT	1048, 1082	
DV351	ACURA	2		FIAT	330		LOTUS	630		VOLVO	1408, 1410, 1426, 1428	
	HONDA	482, 486, 488, 490, 492	DW320	FIAT	324, 326, 356		MG	726, 728, 730, 732	DX720	RENAULT	1024, 1026, 1036, 1038, 1070, 1080	
	ROVER	1104, 1110		LANCIA	590		ROVER	1096, 1098, 1102, 1104, 1106, 1108, 1116, 1120	DX721	RENAULT	1026, 1054	
DV360	HONDA	480, 498	DW322	FIAT	324, 326, 356	DW759	LAND ROVER	614	DX722	RENAULT	1054	
	TOYOTA	1256, 1260, 1270		LANCIA	590, 594		ROVER	1096, 1098, 1102, 1104, 1106, 1108, 1116, 1120	DX800	AUDI	52, 76, 78, 84, 92	
DV370	TOYOTA	1256, 1266, 1268, 1302	DW330	LANCIA	590					FORD	442	
DV380	MAZDA	642, 644, 646, 654, 656	DW340	FIAT	356	DW790	VW	1540, 1542		SEAT	1140, 1152, 1154, 1164, 1166, 1170, 1180	
DV410	MAZDA	648, 656, 658		LANCIA	592	DW801	TOYOTA	1280, 1282, 1284, 1286, 1288, 1308		VW	1460, 1478, 1482, 1510, 1530, 1532, 1536, 1550	
DV431	KIA	574	DW370	DAEWOO	294				DX801	AUDI	52, 76, 78, 84, 92	
	MAZDA	636, 638, 640, 654		MERCEDES-BENZ 710, 712, 714, 716, 718, 720, 722		DW830	AUDI	64		SEAT	1140, 1146, 1152, 1154, 1162, 1164, 1166, 1170, 1180	
DV440	NISSAN	780, 782, 806, 808, 812, 816, 820		SSANGYONG	1204, 1206		VW	1544		VW	1456, 1458, 1460, 1478, 1482, 1496, 1510, 1526, 1528, 1530, 1532, 1536, 1550	
DV450	SUBARU	1214	DW372	MERCEDES-BENZ	710, 712, 716, 718	DW860	AUDI	64, 88				
DV460	SEAT	1174	DW373	MERCEDES-BENZ	710, 712, 716, 718	DW861	VOLVO	1398, 1418, 1422, 1436				
	VW	1520, 1522	DW380	MERCEDES-BENZ	700, 716	DW950	TOYOTA	1284, 1288, 1308				
DV540	NISSAN	780, 796, 808, 818		SSANGYONG	1206	DW5757	LAND ROVER	614				
DV541	INFINITI	516	DW381	DAEWOO	292, 294		LOTUS	630				
	NISSAN	808, 812, 818		MERCEDES-BENZ 688, 696, 712, 714, 718			MG	726, 728, 730, 732				
DV542	NISSAN	784, 808		SSANGYONG	1204, 1206	DW5759	LAND ROVER	614				
DV543	SUBARU	1214	DW410	ALFA ROMEO	18, 20, 26		ROVER	1096, 1098, 1102, 1104, 1106, 1108, 1116, 1120		DY030	DACIA	286
DV544	SUBARU	1212	DW420	NISSAN	784, 808, 818						RENAULT	1028, 1056
DV672	FIAT	332, 358, 360, 364, 368, 382, 386	DW540	NISSAN	788, 804, 820	DW861	VOLVO	1398, 1418, 1422, 1436		DY040	RENAULT	1056, 1072
	LANCIA	600, 604	DW560	TOYOTA	1282	DW950	TOYOTA	1284, 1288, 1308			VOLVO	1390, 1392, 1410, 1428
DV675	FIAT	326, 332, 358, 360, 362, 364, 366, 368, 380, 382, 386, 392, 402	DW620	NISSAN	790, 792, 796, 800	DW5757	LAND ROVER	614		DY070	RENAULT	1048
	LANCIA	600, 602	DW630	FORD	416, 418, 430, 452		LOTUS	630		DY130	CITROËN	212, 214, 226, 258, 272, 278, 280
DV680	ALFA ROMEO	14, 16, 18, 34	DW631	FORD	446		MG	726, 728, 730, 732			PEUGEOT	926, 930, 936, 940, 948
	FIAT	320, 322, 336, 348, 350, 360, 370, 372, 376, 386, 388, 390, 394, 396, 406	DW640	FORD	420, 432, 452	DW5759	LAND ROVER	614		DY140	CITROËN	248, 256, 270
	LANCIA	586, 588	DW641	FORD	446		ROVER	1096, 1098, 1102, 1104, 1106, 1108, 1116, 1120			PEUGEOT	968, 978
DV720	LAND ROVER	612, 614	DW642	FORD	446					DY150	CITROËN	214, 258, 280
DV810	MERCEDES-BENZ 670, 672, 676, 682, 684, 718, 720		DW643	FORD	438, 446, 448		VOLVO	1408, 1428			NISSAN	798
	SSANGYONG	1204	DW644	FORD	446	DW060	TOYOTA	1284			PEUGEOT	926
DV820	MERCEDES-BENZ	668	DW645	FORD	448	DW090	VOLVO	1394, 1398, 1400			ROVER	1102
DV850	AUDI	52	DW650	FORD	448	DW390	FIAT	346		DY231	OPEL	856, 884
	SEAT	1152, 1164, 1170, 1178	DW710	ALFA ROMEO	14, 16, 20, 40, 42		IVECO	536, 542			VAUXHALL	1354
	VW	1458, 1476, 1478, 1508, 1510, 1528, 1530, 1542, 1550	DW711	ALFA ROMEO	14, 16, 22, 40	DW391	FIAT	346		DY232	OPEL	836, 886, 894
DV851	SKODA	1188	DW712	ALFA ROMEO	14, 16, 22, 28, 40, 42		IVECO	536, 538, 542, 544, 548			VAUXHALL	1326, 1372, 1378
	VW	1458, 1476, 1478, 1508, 1510, 1528, 1530, 1542, 1550	DW720	FIAT	318, 322, 354		OPEL	872		DY240	OPEL	888
DV880	VW	1544	DW721	ALFA ROMEO	12, 14, 18, 20, 22, 38, 40, 42		RENAULT	1024, 1052			VAUXHALL	1374
DV951	OPEL	876, 880	DW722	ALFA ROMEO	12, 14, 18, 20, 22, 42	DW392	CITROËN	248, 256		DY241	OPEL	840
	VAUXHALL	1344, 1368	DW723	FIAT	318, 320, 322, 326, 354, 370		FIAT	344			VAUXHALL	1330, 1332
DV990	NISSAN	814		LANCIA	584, 588, 592		IVECO	544, 546		DY250	CHEVROLET	178
DV991	NISSAN	816	DW730	BMW	154		PEUGEOT	978			DAEWOO	290, 294, 296
DW170	OPEL	846, 850	DW731	BMW	138, 152, 154						OPEL	842, 844, 874, 890
	VAUXHALL	1350, 1352, 1362		LAND ROVER	614	DW400	CITROËN	248, 256			VAUXHALL	1332, 1340, 1350, 1366, 1376
DW260	ALFA ROMEO	10, 28		OPEL	876		IVECO	538, 542		DY251	OPEL	858, 882
DW261	ALFA ROMEO	28, 44		VAUXHALL	1368	DW480	FORD	462			VAUXHALL	1358, 1370
DW280	ALFA ROMEO	10, 26	DW750	ROVER	1100, 1102, 1104, 1118	DW550	FORD	458, 466		DY253	OPEL	874
DW281	ALFA ROMEO	40, 42	DW754	LOTUS	630	DW560	RENAULT	1080, 1082			VAUXHALL	1366
DW282	ALFA ROMEO	40, 42		MG	726, 728, 732	DW570	RENAULT	1080, 1082		DY254	OPEL	858
DW300	ALFA ROMEO	10, 12		ROVER	1096, 1106, 1110, 1116	DW580	RENAULT	1074, 1076			VAUXHALL	1356
			DW755	ROVER	1100, 1102, 1104, 1118	DW590	RENAULT	1074		DY255	OPEL	858
			DW756	ROVER	1100, 1102, 1104, 1108, 1118	DW600	RENAULT	1028, 1032, 1044, 1046, 1058, 1072			VAUXHALL	1356
										DY260	OPEL	844, 890
											VAUXHALL	1340, 1350
										DY270	OPEL	846, 892
											SAAB	1126
											VAUXHALL	1342, 1350

NUMERICAL PARTS LIST









Numerische Teilenummernliste • Liste des références produits
Lista de referencias









											
DY271	OPEL	846, 876	DY900	NISSAN	798	EA801	FORD	442	EB5370	AUDI	76, 78, 82
	VAUXHALL	1342, 1368	DZ010	AUDI	70		VW	1496		SEAT	1140, 1142, 1152, 1154, 1164, 1166, 1172
DY272	OPEL	892		SEAT	1152, 1154, 1164, 1170, 1172, 1178	EA900	VW	1464, 1486, 1518		SKODA	1188, 1192, 1194, 1196
	VAUXHALL	1376		SKODA	1192, 1194	EA3130	SEAT	1156, 1160, 1174		VW	1452, 1460, 1480, 1482, 1484, 1496, 1498, 1500, 1510, 1512, 1514, 1530, 1534, 1536, 1542
DY300	OPEL	876, 882		VW	1450, 1452, 1460, 1478, 1480, 1500, 1528, 1530, 1532	EA5020	MINISUBISHI	764			
	SAAB	1130	DZ121	BMW	138, 152, 154, 160	EA5420	ALFA ROMEO	14, 16, 18, 20, 22, 24, 28, 38, 40, 42			
	VAUXHALL	1368, 1370					FIAT	318, 370, 384			
DY301	SAAB	1134	DZ130	BMW	126, 170		LANCIA	584, 588, 592	EB5400	LAND ROVER	612
DY310	CITROËN	246, 260, 266, 268	DZ160	MERCEDES-BENZ	710, 712, 718, 722	EA5470	VW	1492, 1542, 1544		ROVER	1106, 1108, 1110, 1112, 1114
	FIAT	400		SSANGYONG	1204, 1206	EA5620	RENAULT	1048, 1082			
	LANCIA	606		VW	1492		VOLVO	1406, 1408, 1410, 1426, 1428	EB5541	OPEL	834, 836, 838, 848, 852, 868, 870, 884, 886, 894
	PEUGEOT	960, 968, 972	DZ180	VW	1468, 1520, 1526, 1546	EA5780	ALFA ROMEO	24, 30		VAUXHALL	1322, 1324, 1326, 1336, 1350, 1354, 1358, 1372, 1378
DY360	VOLVO	1398, 1420, 1436	DZ181	SEAT	1144, 1148, 1150, 1158, 1160, 1162, 1168		LANCIA	594, 600			
DY362	VOLVO	1406, 1418, 1420, 1434, 1436, 1438		SKODA	1188, 1190	EA5830	CITROËN	218, 236, 238, 242, 244, 246, 250, 252, 256, 260, 266, 274, 278	EB5550	MERCEDES-BENZ	666, 718
				VW	1454, 1456, 1464, 1468, 1520, 1522, 1526, 1546		FIAT	340, 378, 380	EB5560	MERCEDES-BENZ	666, 718
DY370	VOLVO	1396, 1398, 1402, 1404, 1414, 1416, 1418, 1420, 1430, 1432	DZ280	HYUNDAI	512		PEUGEOT	936, 942, 944, 948, 958, 960, 968, 972, 978, 980, 982, 988	EB5660	BMW	122, 126, 170
DY371	VOLVO	1396, 1414, 1430	DZ350	TOYOTA	1254		TOYOTA	1274	EB5670	OPEL	842, 844, 874, 880, 882, 888, 890, 892, 896
DY382	FIAT	318, 320, 352, 366, 368	DZ440	HONDA	478, 490	EA5920	LAND ROVER	614		SAAB	1132
	LANCIA	602		LAND ROVER	614		MG	730		VAUXHALL	1332, 1336, 1366, 1370, 1374, 1376, 1380
DY383	FIAT	318, 320, 352, 358, 366, 382		MG	728, 730		ROVER	1096, 1098, 1108, 1112, 1120	EB5671	OPEL	858
	LANCIA	602, 604	DZ490	FORD	440	EA5940	FORD	470		VAUXHALL	1356
DY390	ALFA ROMEO	12, 14	DZ491	FORD	448	EA5970	FORD	448, 470	EB5700	AUDI	66
DY391	ALFA ROMEO	12, 14	DZ630	JEEP	566	EB610	TRIUMPH	1314		SEAT	1144, 1146, 1158, 1168, 1170, 1174
DY410	FIAT	320, 324, 354	DZ660	BMW	142, 152, 156, 162, 168	EB950	OPEL	876, 880		SKODA	1186, 1188, 1196
DY470	LAND ROVER	612, 614		LAND ROVER	616		VAUXHALL	1344, 1368		VW	1448, 1454, 1466, 1468, 1496, 1498, 1520, 1524
DY520	BMW	126	DZ661	BMW	128, 148	EB960	AUDI	64	EB5900	LAND ROVER	610, 612
DY541	BMW	126	DZ690	LAND ROVER	614	EB961	SEAT	1144, 1146, 1148, 1150, 1156, 1158, 1160, 1162, 1168	EC010	AUDI	54, 56, 62, 64, 86, 96, 98
DY542	BMW	126		MG	730		SKODA	1188, 1190		FORD	442
DY570	BMW	130	DZ720	FORD	436, 438, 468, 474		VW	1454, 1456, 1464, 1468, 1494, 1516, 1518, 1520, 1522, 1526, 1546	EC030	AUDI	52, 76, 78, 84, 92
DY571	BMW	130, 146	DZ790	FIAT	332, 360, 370, 386	EB970	AUDI	50, 52, 54, 60, 84, 92, 96		SEAT	1140, 1146, 1152, 1154, 1162, 1164, 1166, 1170, 1178, 1180
DY580	MERCEDES-BENZ	692	DZ860	MERCEDES-BENZ	672, 684		SEAT	1142, 1154, 1156, 1166, 1180		SKODA	1188
DY590	MERCEDES-BENZ	672, 686	DZ870	MERCEDES-BENZ	674, 686		VW	1462, 1468, 1484, 1502, 1512, 1526, 1536, 1546, 1550		VW	1456, 1458, 1460, 1476, 1478, 1482, 1508, 1510, 1526, 1528, 1530, 1532, 1536, 1550
DY601	MERCEDES-BENZ	704	DZ881	MERCEDES-BENZ	670, 676, 682, 708				EC060	AUDI	70
DY620	SEAT	1150, 1162	DZ891	MERCEDES-BENZ	672, 678, 708	EB9120	FORD	426, 428, 432, 436, 440		SEAT	1140, 1152, 1154, 1164, 1166, 1170, 1172, 1178
	VW	1468, 1546		SSANGYONG	1204, 1206		MAZDA	634, 650, 652		SKODA	1192, 1194
DY640	FORD	426	DZ900	DAEWOO	292, 294	EB5140	VOLVO	1402, 1406, 1428		VW	1450, 1452, 1458, 1460, 1478, 1480, 1500, 1528, 1530, 1532
DY641	FORD	458		MERCEDES-BENZ	672, 686, 700	EB5140	OPEL	828, 848, 850			
DY650	FORD	428	DZ910	SEAT	1152, 1162, 1178		VAUXHALL	1320, 1352	EB5150	FIAT	322, 332, 354, 356, 358, 360, 382
	MAZDA	636		VW	1472, 1474, 1476, 1506, 1508, 1528, 1548					LANCIA	584, 588, 592
DY651	FORD	428	DZ960	AUDI	78, 86	EB5240	OPEL	828, 832, 850		VAUXHALL	1320, 1352
	MAZDA	636					VAUXHALL	1320, 1352	EB5360	OPEL	834, 852
DY660	FORD	430, 456	EA140	RENAULT	1024, 1042, 1086, 1090					VAUXHALL	1322, 1354, 1378
DY671	FORD	414, 428, 444	EA150	RENAULT	1042, 1054						
	MAZDA	636	EA220	DACIA	286						
DY710	HYUNDAI	502, 508		RENAULT	1028, 1056						
DY730	HYUNDAI	502, 510	EA440	FORD	414, 416, 418, 428, 430, 450						
DY735	HYUNDAI	502, 506	EA441	FORD	414, 416, 418, 428, 430, 450, 452, 462						
DY740	FORD	414, 428, 450	EA800	VW	1542						
DY741	FORD	416, 428, 450									
DY750	AUDI	84, 92, 96									
DY751	AUDI	54, 62, 84, 92, 96									
DY752	AUDI	54, 62, 84, 92, 96									
DY753	SEAT	1142, 1154, 1166, 1180									
	VW	1462, 1484, 1512, 1536, 1550									
DY850	AUDI	56, 80, 88, 90, 92, 98									
DY863	HONDA	486, 488									

							
EC102	OPEL 858 VAUXHALL 1356	ED5500	CITROËN 234, 236, 238, 252 FIAT 378, 396 FORD 438, 442, 468 LANCIA 596 PEUGEOT 948, 962, 970, 974, 982 VOLVO 1402, 1410, 1420, 1428, 1430	EE5250	VOLVO 1402, 1404, 1406, 1412, 1414, 1416, 1418, 1420, 1422, 1430, 1432, 1434, 1436, 1438, 1440 OPEL 838, 848, 856, 870 VAUXHALL 1328, 1336, 1352, 1356, 1360	EG873	AUDI 50, 52, 56, 58, 94 SEAT 1150, 1160, 1168, 1176, 1178 VW 1456, 1458, 1466, 1468, 1470, 1474, 1476, 1486, 1488, 1490, 1500, 1502, 1504, 1506, 1508, 1524, 1532, 1534, 1540
EC130	OPEL 840, 844, 874, 888, 890 VAUXHALL 1330, 1332, 1340, 1350, 1366, 1374, 1376	ED5650	AUDI 66 SEAT 1144, 1148, 1158 SKODA 1186, 1196 VW 1464, 1496, 1522	EF07C	AUSTIN 104, 106, 108 MORRIS 774	EG914	LAND ROVER 610, 612, 616 LEYLAND / LDV 628 MG 732 ROVER 1120 TRIUMPH 1314
EC340	VW 1462, 1486, 1516, 1538, 1546, 1552	ED5690	CHEVROLET 178, 180 DAEWOO 294, 298	EF070	AUSTIN 104 MG 732 MORRIS 774	EG920	VOLVO 1396, 1400
EC510	TRIUMPH 1312	ED5720	MERCEDES-BENZ 674, 678, 688, 696, 700, 712	EF074	AUSTIN 104 MG 732 MORRIS 774	EG5000	VW 1544
EC633	TRIUMPH 1312	ED5800	FIAT 368, 369	EF075	AUSTIN 106, 108 MG 732 MORRIS 774	EG5010	VW 1484, 1500, 1514, 1516, 1538
EC651	SAAB 1124	ED5810	FIAT 316, 332, 350, 352, 360, 366, 370 LANCIA 594, 604 OPEL 846, 868	EF101	TALBOT 1236, 1238, 1240, 1242	EG5130	MAZDA 646
EC790	MERCEDES-BENZ 686, 696, 714, 716, 718	ED5820	FIAT 332, 350, 352, 386 LANCIA 594 OPEL 832, 852	EF102	CITROËN 224, 226 PEUGEOT 928, 930, 948 TALBOT 1236, 1238, 1240, 1242	EG5220	MITSUBISHI 766 SUBARU 1212 SUZUKI 1220, 1222, 1224, 1228, 1230
EC791	MERCEDES-BENZ 688, 696, 714, 716	ED5910	ALFA ROMEO 24, 30 LANCIA 600	EF380	DACIA 286 RENAULT 1068	EG5280	SUBARU 1210, 1212, 1214
EC821	MERCEDES-BENZ 688, 702, 704	ED5960	FIAT 326, 356, 386 LANCIA 590, 594, 600	EF460	AUSTIN 104 MG 732	EG5770	HONDA 482
EC5060	MITSUBISHI 740, 768 NISSAN 794, 806, 808 OPEL 872, 894 RENAULT 1030, 1032, 1042, 1044, 1046, 1050, 1056, 1058, 1084, 1088 VAUXHALL 1360, 1376 VOLVO 1408, 1426	ED5991	NISSAN 806 OPEL 894 RENAULT 1030, 1032, 1042, 1044, 1048, 1056, 1058, 1084, 1086, 1090 VAUXHALL 1378	EF462	AUSTIN 108	EG5810	HONDA 478, 498
EC5061	RENAULT 1042, 1046, 1056, 1084	EE350	TRIUMPH 1312, 1314	EF464	AUSTIN 104, 106, 108 MG 726 ROVER 1118	EG6210	HONDA 480, 498
EC5220	AUDI 66, 72, 82 SEAT 1142, 1150, 1160, 1170, 1176 SKODA 1190 VW 1448, 1466, 1498, 1500, 1502, 1524	EE532	JAGUAR 552	EF580	PEUGEOT 962, 984	EG6220	MITSUBISHI 740, 766
EC5410	BMW 120, 130, 132, 148, 166	EE781	MORRIS 774	EF731	RENAULT 1062	EG6230	MITSUBISHI 750
EC5560	CHRYSLER 184, 188	EE5110	RENAULT 1024, 1032, 1042, 1048, 1058, 1086, 1092	EF870	RENAULT 1040, 1068, 1088	EG6240	MITSUBISHI 528 OPEL 870 VAUXHALL 1358, 1360
EC5620	MERCEDES-BENZ 670, 672, 678, 682, 684, 710, 718, 720	EE5150	VOLVO 1424, 1440	EF5380	AUDI 68, 70, 72, 78, 84 SEAT 1142, 1164, 1172, 1174, 1180 SKODA 1186, 1192, 1194, 1196 VW 1458, 1460, 1462, 1482, 1484, 1490, 1492, 1496, 1510, 1514, 1536, 1538, 1540, 1542	EG6250	TOYOTA 1262
EC5660	SMART 1200	EE5180	FIAT 318, 320, 352, 358, 366, 368, 382 LANCIA 602	EG091	MG 732 TRIUMPH 1312	EG6260	SUZUKI 524
EC5670	SMART 1200	EE5181	ALFA ROMEO 16, 18, 22, 38 FIAT 320, 322, 324, 332, 352, 354, 358, 360, 370, 384 LANCIA 594 OPEL 840, 841, 880, 888, 896 SAAB 1130, 1132 VAUXHALL 1332, 1370, 1374, 1378	EG176	JEEP 562, 564, 568 RENAULT 1032, 1034, 1040, 1050, 1070, 1074, 1076, 1078, 1080, 1082, 1088, 1090	EG6270	MITSUBISHI 746, 750, 762 PROTON 990
EC5700	CITROËN 228, 230 PEUGEOT 934	EE5200	DACIA 286 NISSAN 794, 798, 800 RENAULT 1026, 1028, 1040, 1042, 1044, 1050, 1054, 1060, 1082, 1084, 1086, 1092	EG210	LAND ROVER 610	EG6280	MITSUBISHI 746, 748, 768, 770
EC5800	FORD 412, 438, 440, 446, 448, 468, 474 MAZDA 656	EE5220	NISSAN 794, 806 OPEL 872, 894 RENAULT 1024, 1034, 1048, 1050, 1090, 1092 VAUXHALL 1360, 1362, 1378	EG212	CARBODIES 176 LAND ROVER 610	EG6290	TOYOTA 1260, 1270, 1272
EC5890	FORD 428, 444	EE5242	FIAT 358, 364, 386 LANCIA 604	EG340	FORD 414, 426	EG6310	TOYOTA 1252, 1254, 1300
EC5921	CHRYSLER 184, 186 MINI 736			EG411	LEYLAND / LDV 626 MG 732	EG6390	ALFA ROMEO 26 FIAT 328, 352, 384
ED770	LAND ROVER 610			EG571	JAGUAR 552	EG6410	ALFA ROMEO 26 FIAT 330
ED771	LAND ROVER 610			EG851	BEDFORD 112 VAUXHALL 1378	EG67450	ALFA ROMEO 24, 26 FIAT 328
ED890	AUSTIN 104					EG7800	FORD 444 SEAT 1142, 1174, 1182 VW 1452, 1454, 1484, 1514
ED5130	CITROËN 228, 232, 270 FORD 430, 438, 440 PEUGEOT 928, 934, 938, 946, 974					EG7950	RENAULT 1026, 1042, 1090
ED5180	CITROËN 216, 228, 232, 272 PEUGEOT 936, 938, 946, 986					EG8230	INFINITI 516 NISSAN 782, 796, 800 RENAULT 1034, 1092
ED5220	FORD 438, 440, 446, 448 VOLVO 1408, 1428					EG9000	BMW 140, 142, 152, 154, 156, 162, 168
ED5300	CITROËN 234, 236, 238, 242, 244, 252, 260, 276 PEUGEOT 936, 946, 956, 958, 968, 972, 980					EG9030	CITROËN 228, 230, 232 PEUGEOT 934, 936, 946, 974
ED5490	CITROËN 236, 238 FIAT 400 LANCIA 596 PEUGEOT 960, 970, 974					EG9190	KIA 572
						EG9270	LEXUS 618

NUMERICAL PARTS LIST









Numerische Teilenummernliste • Liste des références produits
Lista de referencias









							
EG9310	CITROËN 224 DAIHATSU 304, 308 PEUGEOT 928 TOYOTA 1252, 1296, 1308, 1310	EH952	CITROËN 212, 214, 218, 220, 226, 256, 258, 278, 280 PEUGEOT 924, 926, 928, 930, 940, 948, 952, 984, 986	EL960	OPEL 828 RENAULT 1028, 1030, 1032, 1036, 1038, 1040, 1044, 1046, 1056, 1058, 1064, 1066, 1068, 1072, 1074, 1080, 1086, 1088 VAUXHALL 1320 VOLVO 1386, 1388, 1390, 1392, 1410, 1428	ES580	RENAULT 1024, 1026, 1036, 1038, 1070, 1080
EG9540	BMW 120, 134, 138, 142, 144, 152, 160, 162, 168, 172, 174	EJ161	BEDFORD 112 OPEL 874, 876, 878 VAUXHALL 1344, 1358, 1368	EM531	CITROËN 230 FIAT 338 PEUGEOT 982	ES720	LADA 578 OPEL 842, 844, 866, 888, 890 VAUXHALL 1334, 1340, 1350
EG9570	OPEL 842, 882, 896 VAUXHALL 1332, 1334, 1378, 1380	EJ603	HYUNDAI 506, 508, 512 MITSUBISHI 752, 754	EM682	ROVER 1106, 1112, 1114	ES790	LAND ROVER 612 ROVER 1106, 1108, 1110, 1112, 1114
EG9600	AUDI 70 SEAT 1142, 1174, 1180 SKODA 1194 VW 1462, 1484, 1490, 1512, 1514, 1538	EK451	AUSTIN 104, 106, 108 ROVER 1116	EM684	AUSTIN 104, 108 LEYLAND / LDV 622, 626 MG 726, 734	ES820	CITROËN 244, 246, 248, 254, 260, 266, 268, 282 FIAT 338, 398, 400 LANCIA 606 PEUGEOT 944, 946, 956, 960, 966, 968, 970, 972, 978
EG9660	CHRYSLER 190	EK470	BEDFORD 110 OPEL 828, 830, 832, 834, 848, 850, 852, 854, 860, 862, 868, 884 VAUXHALL 1322, 1324, 1334, 1336, 1338, 1344, 1346, 1350, 1354, 1355, 1362, 1364	EM685	LEYLAND / LDV 624 ROVER 1118	ES880	HONDA 486, 492, 494, 498
EG9690	JEEP 568	EK481	BEDFORD 110 OPEL 830, 864 VAUXHALL 1326, 1338, 1346	EM720	MERCEDES-BENZ 664, 670, 680, 682, 710, 712, 714, 716, 718, 720, 722 SSANGYONG 1204, 1206	ES890	HONDA 494, 496
EG9710	CITROËN 268, 270 PEUGEOT 960, 968 RENAULT 1034, 1048, 1082	EK482	DAEWOO 290, 296 OPEL 830, 832, 844, 858, 864, 866, 868, 872, 874, 878, 886, 888, 890 VAUXHALL 1330, 1332, 1334, 1338, 1340, 1342, 1344, 1348, 1356, 1366	EM850	CARBODIES 176 LAND ROVER 610 LEYLAND / LDV 628	ET190	FORD 420, 422, 424, 434, 454, 456, 464
EG9750	CITROËN 238 PEUGEOT 960, 962, 970, 974	EK484	BEDFORD 110 DAEWOO 290, 294 OPEL 830, 836, 856, 864, 884, 886 VAUXHALL 1324, 1326, 1328, 1336, 1338, 1346, 1364	EM852	AUSTIN 106 LAND ROVER 610	ET191	FORD 420, 422, 424, 434, 454, 456, 464
EG9760	RENAULT 1042, 1058, 1084, 1088	EK485	BEDFORD 110, 112 OPEL 830, 838, 864, 886 VAUXHALL 1326, 1328, 1336, 1338, 1346	EM940	FORD 416, 432	ET192	FORD 420, 422, 424, 434, 436, 448, 454, 456 MAZDA 638
EG9770	OPEL 882, 892 RENAULT 1034, 1092 SAAB 1134 VAUXHALL 1370, 1376	EK486	OPEL 840 VAUXHALL 1330, 1336	EM992	HONDA 482, 484, 494, 498 ROVER 1102	ET400	CITROËN 240, 250 FIAT 360, 368, 382, 388, 390, 392, 406
EH445	VOLVO 1384, 1386, 1388, 1392, 1394, 1396, 1398, 1400	EL080	FORD 444, 466	EN260	FORD 470, 472	ET490	FORD 462, 466, 472
EH680	RENAULT 1024, 1034, 1036, 1038, 1062, 1064, 1066, 1070, 1074, 1078	EL650	CITROËN 216, 220, 222, 224, 244, 258, 262, 264, 274, 280, 282 FIAT 396 PEUGEOT 932, 934, 938, 940, 950, 952, 954, 956, 970, 980	EN720	MERCEDES-BENZ 666, 686, 688, 696, 700, 712, 714, 716, 718 SSANGYONG 1204, 1206	ET560	SAAB 1124, 1126, 1128, 1130, 1132
EH682	RENAULT 1062, 1064, 1066	ER280	FIAT 326, 352, 364, 366, 368	EP280	FIAT 326, 352, 364, 366, 368	ET681	BMW 130, 136, 146, 148, 150
EH684	RENAULT 1060, 1062, 1064, 1080	ER241	NISSAN 786, 816, 818	ER241	NISSAN 786, 816, 818	ET750	RENAULT 1082
EH690	JAGUAR 552, 554	ER320	ROVER 1096, 1100, 1102, 1104, 1108, 1118, 1120	ER321	MG 728 ROVER 1096, 1100, 1102, 1104, 1108, 1118, 1120	ET800	FORD 472 LEYLAND / LDV 624
EH694	RENAULT 1040, 1088	ER322	LAND ROVER 614 LOTUS 630 MG 726, 728, 730, 732 ROVER 1096, 1098, 1104, 1106, 1108, 1110, 1116	ER322	LAND ROVER 614 LOTUS 630 MG 726, 728, 730, 732 ROVER 1096, 1098, 1104, 1106, 1108, 1110, 1116	ET811	SEAT 1152, 1164, 1176 VW 1460, 1474, 1490, 1508, 1534
EH700	TRIUMPH 1312	ER830	BMW 122, 124, 144	ER830	BMW 122, 124, 144	ET820	OPEL 850, 860, 868 VAUXHALL 1320, 1362
EH750	FORD 412, 418	ER993	ISUZU 528 OPEL 846, 858, 870 VAUXHALL 1358	ES260	DAEWOO 292 OPEL 832, 834, 836, 838, 846, 848, 854, 862 VAUXHALL 1322, 1324, 1326, 1336, 1346, 1350, 1352, 1354, 1355, 1362, 1364	EV020	HONDA 482, 484, 486, 488, 490, 492
EH752	FORD 414, 426, 428, 450	ES260	DAEWOO 292 OPEL 832, 834, 836, 838, 846, 848, 854, 862 VAUXHALL 1322, 1324, 1326, 1336, 1346, 1350, 1352, 1354, 1355, 1362, 1364	ES471	AUDI 50, 54, 60, 96 SEAT 1154, 1166, 1180 VW 1462, 1484, 1512, 1550	EV050	HONDA 486, 488, 490, 492
EH761	FORD 412, 418 LOTUS 630	EH890	CITROËN 216, 218, 222, 224, 226, 230, 240, 242, 244, 246, 250, 252, 254, 260, 264, 266, 272, 274, 276, 280, 282 FIAT 334, 336, 338, 378, 396 HONDA 490 LADA 578 LEYLAND / LDV 622, 624 PEUGEOT 932, 934, 940, 942, 944, 950, 952, 954, 956, 958, 970, 976, 980, 982, 986, 988 ROVER 1106, 1110 SUZUKI 1220, 1226, 1230 TALBOT 1238	EV150	CITROËN 246, 260, 268, 270 FIAT 400 LANCIA 606 PEUGEOT 960, 968, 972	EV190	RENAULT 1024, 1036, 1038, 1078, 1090
EH831	JAGUAR 552, 554, 556	EH872	MERCEDES-BENZ 664, 680, 682, 684, 696	EV460	SEAT 1148, 1150, 1156, 1158, 1162, 1174 VW 1464, 1468, 1486, 1516, 1518, 1520, 1522, 1526, 1546	EV540	INFINITI 516 NISSAN 780, 784, 796, 808, 812, 818
EH850	FORD 412, 418, 426, 444, 456, 458, 462, 464, 466, 468, 470	EH881	MERCEDES-BENZ 696	EV670	FIAT 332, 358, 360, 364, 368, 382, 386 LANCIA 600	EV684	ALFA ROMEO 14 FIAT 320, 322, 336, 348, 350, 360, 370, 372, 386, 390, 394, 396, 406
EH872	MERCEDES-BENZ 664, 680, 682, 684, 696	EH890	LEYLAND / LDV 622 PEUGEOT 964, 966, 984 TALBOT 1242				
EH881	MERCEDES-BENZ 696	EH950	CITROËN 220, 224, 226, 254, 262 PEUGEOT 922, 924, 928, 930 TALBOT 1240				
EH890	LEYLAND / LDV 622 PEUGEOT 964, 966, 984 TALBOT 1242	EH951	CITROËN 212, 214, 216, 218, 220, 226, 228, 230, 256, 258, 270, 278, 280 PEUGEOT 924, 926, 928, 930, 934, 940, 946, 948, 952, 974, 976, 984, 986				

											
EV720	LAND ROVER	612, 614	EY671	FORD	414, 428, 444	FD5690	CHEVROLET	178, 180	FG7830	KIA	574
EV810	MERCEDES-BENZ	668, 670, 672, 676, 678, 682, 684, 686, 700, 708, 710, 712, 718, 720, 722		MAZDA	636		DAEWOO	294, 298	FG7840	KIA	574, 576
	VW	1492	EY840	AUDI	72, 74, 76, 82, 90	FD5810	FIAT	316, 332, 350, 352, 360, 366, 370	FG7850	MAZDA	640
EW320	FIAT	356		VW	1506		LANCIA	594, 604	FG7860	HONDA	496
	LANCIA	590	EY841	AUDI	68, 74, 100		OPEL	846, 868	FG7880	NISSAN	792, 798
EW630	FORD	412, 416, 418, 420, 430, 432, 446, 448, 452		SEAT	1140, 1152, 1164, 1172, 1176	FD5820	FIAT	332, 350, 352, 386	FG7910	HYUNDAI	502, 506, 508
	FORD	412, 416, 418, 420, 430, 432, 446, 448, 452		SKODA	1190, 1196		LANCIA	594, 604	FG7960	HONDA	494
EW730	BMW	138, 152, 154		VW	1448, 1474, 1476, 1498, 1508, 1528, 1534	FD5970	FIAT	322, 332, 354, 356, 360, 382	FG7980	SUBARU	1216
EW802	BMW	130, 132, 134, 136, 140, 142, 146, 148, 150, 156, 160, 162, 168, 170, 172, 174	EY850	AUDI	56, 80, 88, 90, 92, 98				FG7990	DAEWOO	290, 294
	TOYOTA	1286		VOLVO	1384, 1386	FE603	ZASTAVA	1554	FG8000	DAEWOO	290, 292, 296
EW860	AUDI	60, 64, 88	EZ142	HONDA	478, 490	FE5470	KIA	574	FG8010	HONDA	498
EW861	VOLVO	1398, 1418, 1422, 1436	EZ440	ROVER	1096, 1098, 1108, 1112	FF24R	ALFA ROMEO	32, 38, 40	FG8040	HYUNDAI	502, 508
EW870	OPEL	870, 880	EZ441	LAND ROVER	614	FF5030	LEXUS	618	FG8050	HYUNDAI	502
	VAUXHALL	1368		MG	728, 730		TOYOTA	1264, 1280, 1294, 1302	FG8060	HYUNDAI	502, 506
EX270	FORD	470		ROVER	1096, 1098, 1108, 1112, 1120	FF5070	HYUNDAI	510, 512		KIA	574
EX480	FORD	462	EZ630	JEEP	566	FF5470	MITSUBISHI	740, 742, 756, 760, 768	FG8090	HYUNDAI	514
EX550	FORD	442, 458, 466	EZ660	BMW	142, 152, 156, 162, 168	FF5490	MITSUBISHI	764, 766	FG8100	SUZUKI	1224
EX932	BMW	130, 132, 136, 146, 148, 150, 170		LAND ROVER	616	FF5541	NISSAN	784, 808, 822	FG8130	HONDA	490, 494
	BMW	136, 148	EZ690	LAND ROVER	614	FF5600	NISSAN	802	FG8131	HONDA	490, 492, 494, 498
EX934	BMW	136, 148		MG	730	FF5690	INFINITI	516	FG8140	KIA	572
EX980	VOLVO	1384, 1394, 1396, 1400		ROVER	1100		NISSAN	792, 800, 804, 820	FG8150	MAZDA	658
	VW	1492, 1494	EZ720	FORD	436, 438, 468, 474	FF5740	NISSAN	788, 792, 794, 802, 804, 818	FG8170	MAZDA	634
EX995	AUDI	54, 56, 58, 60, 62, 64, 66, 86, 92, 94, 96, 98	EZ800	BMW	128, 148	FF5760	SUBARU	1216	FG8190	MAZDA	636, 654
	VW	1512, 1514, 1532	FA5130	MAZDA	650, 654	FF5781	TOYOTA	1248, 1250, 1252, 1282, 1286, 1288, 1296, 1310	FG8200	KIA	572, 576
EY070	RENAULT	1034, 1048, 1082	FA5390	MITSUBISHI	746, 752, 754, 758, 760, 762, 766, 768, 770	FF5790	TOYOTA	1292	FG8250	KIA	574
EY130	CITROËN	212, 214, 226, 258, 272, 278, 280	FA5560	ALFA ROMEO	16, 22	FF5800	TOYOTA	1292	FG8260	KIA	572
	PEUGEOT	926, 930, 936, 940, 948		FIAT	334, 354, 358, 370, 384, 386	FF5860	TOYOTA	1248, 1292	FG8290	HYUNDAI	504, 508
EY140	CITROËN	248, 256, 270		LANCIA	594	FG210	LAND ROVER	610	FG8291	HYUNDAI	502, 512
	PEUGEOT	968, 978	FB5000	TOYOTA	1258, 1270, 1272, 1276, 1292, 1306	FG5100	LEXUS	618	FG9660	CHRYSLER	190
EY200	LAND ROVER	612, 616	FB5001	TOYOTA	1252, 1308	FG5130	MAZDA	646	FG9770	OPEL	882, 892
EY230	OPEL	834, 836, 838, 848, 854, 856, 884, 886, 894	FB5100	ALFA ROMEO	34, 36	FG5290	DAIHATSU	302, 304, 306, 308, 310		SAAB	1134
	VAUXHALL	1322, 1324, 1326, 1328, 1336, 1354, 1372, 1378		FIAT	340, 342, 344	FG5581	SUBARU	1210, 1212		VAUXHALL	1370, 1376
EY270	BMW	128		IVECO	534, 536, 538, 540, 542, 544, 546	FG5590	SUBARU	1210, 1212	FJ051	NISSAN	780, 786
EY280	BMW	138, 152, 154, 160		RENAULT	1052	FG5600	SUBARU	1214, 1216	FJ127	MAZDA	648
	JEEP	564	FB5101	FIAT	342, 344	FG5690	HYUNDAI	504, 510, 512, 514	FJ232	MAZDA	654
	LAND ROVER	614		IVECO	534, 540, 542	FG5760	HONDA	496	FJ290	TOYOTA	1286
	OPEL	876	FB5102	FIAT	340, 342	FG5761	HONDA	480	FJ491	NISSAN	780
	VAUXHALL	1368		IVECO	546, 548	FG5920	DAIHATSU	304, 308	FJ495	NISSAN	802
EY300	OPEL	846, 876, 892	FB5610	NISSAN	782, 784, 786, 792, 808, 812, 818	FG6040	HYUNDAI	502, 506	FJ631	MAZDA	638, 650, 652, 656
	VAUXHALL	1342, 1368, 1376	FB5720	FIAT	340	FG6120	MITSUBISHI	744, 746, 754, 760, 764, 766, 772	FJ632	MAZDA	638, 650, 652, 656
EY370	VOLVO	1396, 1398, 1402, 1406, 1414, 1416, 1418, 1420, 1424, 1430, 1432, 1434, 1436, 1438		LANCIA	598	FG7480	TOYOTA	1250, 1274, 1276, 1298, 1300, 1306	FJ651	MAZDA	638
	BMW	130, 134, 140, 146, 148, 150, 156, 160, 172	FB5721	FIAT	340	FG7570	TOYOTA	1304	FJ652	MAZDA	638
EY580	MERCEDES-BENZ	692, 698, 702		IVECO	542	FG7600	MINI	736	FJ653	MAZDA	638
EY590	MERCEDES-BENZ	672, 674, 686	FB5750	TOYOTA	1248, 1252, 1268, 1282, 1288, 1298, 1300, 1304, 1308, 1310		TOYOTA	1266, 1282, 1304, 1308, 1310	FJ690	MITSUBISHI	744
EY650	FORD	428, 430, 432, 436, 438, 456	FD770	LAND ROVER	610	FG7630	LEXUS	618	FJ911	DAIHATSU	310
	MAZDA	634, 636	FD5230	HONDA	486, 488, 490, 492	FG7650	TOYOTA	1250, 1252, 1254, 1274, 1276, 1280, 1292, 1294, 1300, 1304, 1306, 1308	FJ912	DAIHATSU	310
			FD5330	TOYOTA	1250, 1252, 1258, 1276, 1294, 1298, 1300, 1308	FG7680	MITSUBISHI	760	FJ960	TOYOTA	1278
			FD5380	TOYOTA	1282, 1298, 1308, 1310	FG7690	MITSUBISHI	742, 754	FJ962	TOYOTA	1262, 1278
						FG7710	MITSUBISHI	768	FN307	ALFA ROMEO	8, 10
							VOLVO	1408, 1426	FN308	ALFA ROMEO	30
									FN353	ALFA ROMEO	6, 30, 32
										NISSAN	790
									FN355	ALFA ROMEO	6, 12, 36
									FX182	ISUZU	520, 522, 526
									FX270	FORD	470
									FX660	LADA	578, 580

NUMERICAL PARTS LIST









Numerische Teilenummernliste • Liste des références produits
Lista de referencias









							
FY291	ALFA ROMEO 34, 36	GE360	MAZDA 652	GJ611	HONDA 482	GK590	FIAT 346, 348
	FIAT 318, 324, 330, 340, 356	GE392	TOYOTA 1282	GJ650	ISUZU 520, 522, 526	GK671	TOYOTA 1252, 1260, 1264, 1276, 1278, 1308
	IVECO 534, 536, 538, 540, 544, 546	GE410	MITSUBISHI 740, 750	GJ653	ISUZU 520, 522, 526	GK700	TOYOTA 1262
	OPEL 828, 872	GE541	FORD 412	GJ655	ISUZU 522	GK701	TOYOTA 1262
	RENAULT 1050, 1052, 1090	GE550	SUZUKI 1222, 1224	GJ660	TOYOTA 1264, 1278, 1298	GK750	NISSAN 820
	VAUXHALL 1320, 1362	GE621	ALFA ROMEO 6	GJ661	TOYOTA 1264, 1298	GK930	TOYOTA 1290
FY320	FIAT 326	GE622	ALFA ROMEO 6, 32	GJ720	CITROËN 216, 218, 222, 224, 226, 230, 240, 242, 244, 246, 250, 252, 254, 260, 264, 266, 272, 274, 276, 280, 282	GL280	SUBARU 1216
	LANCIA 590		NISSAN 790		FIAT 334, 336, 338, 378, 396	GL281	SUBARU 1216
FY520	ALFA ROMEO 24, 30	GE623	ALFA ROMEO 6, 12		HONDA 490	GL310	NISSAN 812, 822
	FIAT 356	GF051	CITROËN 212, 244, 254		LADA 578	GL321	KIA 576
	LANCIA 590, 594	GF053	CITROËN 252, 260		LEYLAND / LDV 622, 624		MAZDA 646, 648
FY550	ALFA ROMEO 14, 16, 22	GF054	CITROËN 252, 260		PEUGEOT 932, 934, 940, 942, 944, 950, 952, 954, 956, 958, 970, 976, 980, 982, 986, 988	GL340	DAIHATSU 304
	FIAT 320, 322, 354, 358	GF110	TALBOT 1236		ROVER 1106, 1110		TOYOTA 1268, 1278, 1302
	LANCIA 592	GF171	TALBOT 1236		SUZUKI 1220, 1226, 1230	GL341	DAIHATSU 304
FY610	ALFA ROMEO 28	GF322	PEUGEOT 962		TALBOT 1238		TOYOTA 1268, 1278, 1302
FY611	ALFA ROMEO 28	GF356	RENAULT 1060	GJ740	TOYOTA 1264, 1290	GL343	TOYOTA 1306
FY620	ALFA ROMEO 24, 30	GF492	CITROËN 214	GJ741	TOYOTA 1282, 1290	GL390	SUZUKI 1226
FY640	ALFA ROMEO 18, 24, 30, 38, 40, 44	GF570	PEUGEOT 938	GJ742	TOYOTA 1264, 1290	GL391	BEDFORD 114
	LANCIA 600	GF583	PEUGEOT 962, 984	GJ852	FIAT 374, 386, 402		SUZUKI 1224, 1226
FY690	FIAT 344	GF874	RENAULT 1068, 1088		ZASTAVA 1554	GL610	PEUGEOT 964
	IVECO 536, 538	GG050	FORD 466	GJ872	FIAT 316, 348, 364, 366, 402, 404	GL650	CITROËN 220, 222, 262, 280, 282
	PEUGEOT 978		PEUGEOT 964, 984	GJ891	MITSUBISHI 752		PEUGEOT 932, 934, 938, 940, 950, 952, 954
FY691	CITROËN 248	GG052	PEUGEOT 964, 966	GJ897	MITSUBISHI 762, 766	GL741	DAIHATSU 304
	FIAT 344		TALBOT 1242	GK044	ISUZU 522		TOYOTA 1256
	IVECO 538, 546	GG452	CITROËN 230, 240	GK047	ISUZU 522	GL760	NISSAN 798
FY811	ISUZU 524, 526, 528		PEUGEOT 984	GK410	MITSUBISHI 746, 748	GL761	NISSAN 798
	MAZDA 642	GG541	CITROËN 232	GK420	MITSUBISHI 744	GL770	NISSAN 788, 792, 802
	OPEL 840, 848, 854, 856, 862, 886		FIAT 316	GK440	NISSAN 790, 810, 814	GL820	DAIHATSU 306, 308
	VAUXHALL 1324, 1330, 1338, 1348, 1352, 1354, 1356, 1364, 1366, 1374	GG724	NISSAN 788, 794, 802, 820	GK441	NISSAN 790, 810, 814		TOYOTA 1280, 1282, 1284, 1286, 1292, 1294, 1302
GC260	TOYOTA 1290	GG725	NISSAN 802, 820	GK444	NISSAN 814	GL830	CITROËN 230, 240
GC261	TOYOTA 1290	GG811	FIAT 372, 376	GK445	NISSAN 792		PEUGEOT 984
GC264	TOYOTA 1290	GH061	MITSUBISHI 766, 770	GK446	NISSAN 806	GL880	MAZDA 652
GC265	TOYOTA 1290	GH062	MITSUBISHI 744, 748, 770, 772	GK447	NISSAN 810, 816	GL950	TOYOTA 1284, 1288
GC272	NISSAN 784, 814	GH064	MITSUBISHI 748, 752, 770	GK448	NISSAN 814	GL951	TOYOTA 1280, 1288
GC374	ALFA ROMEO 8, 32	GH080	JEEP 562, 564	GK461	TOYOTA 1264, 1278, 1280, 1302	GM300	MAZDA 644
GC383	NISSAN 800		RENAULT 1032, 1040, 1050, 1070, 1076, 1078, 1090	GK470	OPEL 828, 830, 860, 862, 868	GM310	FORD 460
GC385	NISSAN 790	GH683	RENAULT 1060, 1062, 1064, 1080	GK541	FIAT 316, 376		LEYLAND / LDV 622, 624
GC388	NISSAN 792, 796, 800	GH690	RENAULT 1088	GK570	ALFA ROMEO 10, 12, 34, 38	GM370	BEDFORD 112
GC790	BMW 122, 124	GH691	RENAULT 1040, 1088		LAND ROVER 614		ISUZU 520, 528
	MERCEDES-BENZ 686, 696, 714, 716, 718	GH700	LADA 578, 580		ROVER 1120		OPEL 846
GC993	TOYOTA 1256	GH740	SUZUKI 1220, 1222	GK571	ALFA ROMEO 6	GM372	ISUZU 520, 528
GC994	TOYOTA 1256	GH856	ALFA ROMEO 8, 10, 32, 36		TOYOTA 1288		OPEL 846
GDD40	MITSUBISHI 744	GH857	ALFA ROMEO 8, 10, 30, 32, 34, 36, 40	GK572	ALFA ROMEO 20, 28		VAUXHALL 1340
GDD42	MITSUBISHI 740, 746	GH858	ALFA ROMEO 8		CHRYSLER 184, 190		SSANGYONG 1204
GDD61	TOYOTA 1260	GH890	FORD 444, 458, 460		FORD 460	GM491	ISUZU 520, 524, 526
GD363	ISUZU 524		LEYLAND / LDV 622, 624		JEEP 562	GM531	PEUGEOT 962, 964, 966
GD671	FIAT 316		PEUGEOT 964, 984		OPEL 858	GM533	FIAT 338
GD790	FIAT 316	GH930	CITROËN 238		ROVER 1116		PEUGEOT 962, 964, 984
GD950	TOYOTA 1286	GJ360	NISSAN 802	GK573	VAUXHALL 1368	GM572	NISSAN 790, 792, 800, 804
GD952	DAIHATSU 302	GJ363	NISSAN 802			GM574	NISSAN 812
	TOYOTA 1266, 1292, 1302, 1306	GJ430	MAZDA 638, 640, 652			GM577	NISSAN 790, 792, 800
GD955	DAIHATSU 302	GJ431	MAZDA 638, 640, 652			GM580	NISSAN 788, 802, 804, 820
	TOYOTA 1264, 1266, 1292, 1302, 1304, 1306	GJ432	MAZDA 638, 652				
GE071	MITSUBISHI 742	GJ600	MITSUBISHI 744, 746, 752, 754, 762, 766				
GE072	MITSUBISHI 742	GJ601	MITSUBISHI 752, 762				
		GJ610	HONDA 482				









											
GM581	NISSAN	788, 802, 804, 820	GN560	SUBARU	1210, 1214, 1216	GP960	NISSAN	780, 806, 812, 816, 820	GR883	DAIHATSU	302, 308, 310
GM596	NISSAN	786	GN561	SUBARU	1210, 1214, 1216	GP970	NISSAN	780, 806, 810, 816	GR890	TOYOTA	1252, 1264, 1290
GM597	NISSAN	786, 812	GN620	MAZDA	652	GP980	BEDFORD	112	GR900	TOYOTA	1270, 1294, 1302
GM690	VW	1540, 1542	GN621	KIA	572, 576		ISUZU	520	GR901	TOYOTA	1256, 1270, 1302
GM710	PEUGEOT	962, 964, 984		MAZDA	652		VAUXHALL	1360	GR920	ISUZU	520
GM730	MAZDA	646, 650, 656	GN622	MAZDA	646, 650, 656	GP990	ALFA ROMEO	8	GR940	ISUZU	520, 528
GM750	DAIHATSU	740, 746, 750	GN640	DAIHATSU	306, 308	GR100	FIAT	404	GR951	TOYOTA	1282, 1308
GM760	NISSAN	780, 812		TOYOTA	1280, 1282, 1284, 1286, 1294	GR130	LANCIA	586	GR961	MAZDA	636
GM761	NISSAN	786	GP011	FIAT	316, 348, 362, 400	GR140	DAIHATSU	304, 306	GR963	KIA	574
GM765	NISSAN	786, 806		SEAT	1156	GR160	NISSAN	798	GR990	ISUZU	520, 522
GM766	NISSAN	788, 814	GP022	FIAT	362, 364	GR161	NISSAN	798		OPEL	846
GM821	NISSAN	784, 788	GP051	FIAT	316, 362	GR190	BEDFORD	112		VAUXHALL	1340
GM830	DAIHATSU	740, 746, 748, 766, 770, 772	GP060	FIAT	348		ISUZU	522, 526	GR991	ISUZU	520, 522, 528
GM880	TOYOTA	1264, 1298	GP070	ZASTAVA	1554		VAUXHALL	1360		OPEL	858
GM881	TOYOTA	1264, 1278, 1286, 1288, 1298	GP190	FIAT	324	GR240	NISSAN	810, 816		VAUXHALL	1358
	VW	1538	GP282	FIAT	362, 364, 392, 402	GR250	TOYOTA	1252, 1258, 1294, 1296	GS050	NISSAN	814, 818
GM883	TOYOTA	1298		LANCIA	602	GR270	TOYOTA	1268, 1292	GS051	NISSAN	818
GM901	DAIHATSU	308, 310	GP285	FIAT	326, 364, 366, 380	GR300	TOYOTA	1264, 1280, 1304	GS060	TOYOTA	1262
GM902	DAIHATSU	308		LANCIA	600, 602	GR301	TOYOTA	1264, 1280, 1304	GS070	MAZDA	642
GM910	SUZUKI	1220	GP286	FIAT	364, 380	GR301	TOYOTA	1260, 1262, 1296	GS111	HONDA	496
GM911	SUZUKI	1220	GP293	FIAT	402	GR332	TOYOTA	1262, 1296	GS120	DAIHATSU	746, 748, 750
GM912	SUZUKI	1220	GP294	FIAT	402	GR360	NISSAN	786, 812, 820, 822	GS130	HYUNDAI	506, 508
GM920	HONDA	496	GP301	FIAT	404, 406	GR480	FIAT	316		DAIHATSU	746, 750, 752, 754, 762, 766, 768
GM990	HONDA	482, 498	GP530	TOYOTA	1256, 1268	GR540	HONDA	482, 486, 490, 492	GS200	NISSAN	788, 804, 818, 820
	ROVER	1102	GP531	TOYOTA	1268	GR541	HONDA	492	GS240	HYUNDAI	508
GM991	HONDA	482, 484, 494	GP540	MAZDA	640	GR560	SUBARU	1212, 1216		DAIHATSU	742, 758, 760
GM992	HONDA	482, 484, 492, 494	GP560	DAIHATSU	306, 308	GR561	SUBARU	1212, 1214, 1216	GS241	HYUNDAI	508
GM993	HONDA	482, 484, 494	GP561	DAIHATSU	306, 308	GR570	TOYOTA	1290		DAIHATSU	742, 758, 760
GN170	NISSAN	790	GP564	DAIHATSU	306, 308	GR581	TOYOTA	1258, 1274, 1276, 1292, 1306	GS280	MAZDA	650, 654
GN190	BEDFORD	112	GP565	DAIHATSU	308	GR600	CHRYSLER	184, 186, 190	GS360	TOYOTA	1248, 1288, 1298, 1306
	ISUZU	522	GP570	MAZDA	642		HYUNDAI	512	GS430	DAIHATSU	302
GN200	TOYOTA	1266, 1302, 1304	GP571	MAZDA	642		DAIHATSU	750, 764	GS435	MAZDA	642
GN201	TOYOTA	1268, 1282, 1306	GP580	NISSAN	792, 810, 818	GR611	FIAT	362	GS438	DAIHATSU	302
GN220	DAIHATSU	744, 758, 760	GP581	NISSAN	792, 810, 818	GR620	FIAT	350, 360, 382, 388, 392, 404	GS600	SUZUKI	1222, 1228
GN221	DAIHATSU	748, 766, 770	GP600	MAZDA	642		ZASTAVA	1554	GS610	NISSAN	816
GN230	DAIHATSU	742, 756, 760	GP601	MAZDA	642	GR630	CITROËN	240, 250	GS612	NISSAN	810
	PROTON	990	GP602	KIA	574		FIAT	350, 376, 388, 392	GS620	LADA	578, 580
GN231	DAIHATSU	742, 756, 760		MAZDA	640		PEUGEOT	978	GS630	LADA	580
GN233	DAIHATSU	742, 756, 760	GP650	TOYOTA	1248, 1280, 1284, 1286, 1304	GR631	FIAT	368, 388, 390	GS700	HONDA	480
	PROTON	990	GP660	FIAT	362	GR632	FIAT	376, 388, 392	GS760	NISSAN	788, 820
GN320	PEUGEOT	962, 984	GP688	LANCIA	598		LANCIA	584, 588	GS770	FORD	446
GN330	DAIHATSU	742, 754, 760	GP689	FIAT	328	GR661	NISSAN	804, 818, 820, 822		NISSAN	804
	PROTON	990	GP730	SUBARU	1212, 1214	GR662	NISSAN	800, 802	GS771	NISSAN	780, 784, 792, 804, 806, 812, 818
GN331	DAIHATSU	742, 754, 760	GP731	SUBARU	1212, 1214	GR670	DAIHATSU	302	GS870	TOYOTA	1298
	PROTON	990	GP840	MAZDA	656	GR730	MAZDA	646, 648	GS881	HONDA	488, 490, 492
GN390	TOYOTA	1256, 1260, 1268, 1270, 1276, 1292, 1294, 1302, 1304, 1308	GP861	FIAT	350, 372, 374, 404	GR731	MAZDA	650		ROVER	1104, 1108
				LANCIA	596	GR732	MAZDA	648, 656	GS910	NISSAN	782
GN450	HONDA	478, 498	GP871	FIAT	372, 374, 402	GR734	MAZDA	648, 656	GS940	MAZDA	654, 656
GN451	HONDA	478, 496	GP920	BEDFORD	112	GR736	MAZDA	644	GS950	MAZDA	642, 644
GN480	SUZUKI	1226		ISUZU	520, 528	GR750	TOYOTA	1256, 1268, 1294	GS953	MAZDA	644
GN481	SUZUKI	1222, 1224, 1226, 1228		OPEL	846	GR751	TOYOTA	1256, 1268, 1294	GS970	TOYOTA	1254, 1262, 1296
GN482	SUZUKI	1222, 1228		VAUXHALL	1340	GR760	DAIHATSU	302	GT050	NISSAN	812
GN483	SUZUKI	1222	GP921	BEDFORD	112		KIA	574, 576		NISSAN	812
GN484	SUZUKI	1228		ISUZU	520		MAZDA	646, 648, 652	GT051	NISSAN	812
GN530	TOYOTA	1304		OPEL	846	GR880	DAIHATSU	302, 306	GT083	DACIA	286
GN551	SUBARU	1214		VAUXHALL	1340	GR881	DAIHATSU	302, 308, 310		RENAULT	1068
GN552	SUBARU	1214	GP950	NISSAN	814	GR882	DAIHATSU	302	GT130	TOYOTA	1278, 1280, 1288

NUMERICAL PARTS LIST

Numerische Teilenummernliste • Liste des références produits
Lista de referencias









									
GT260	FIAT	326, 362, 380	GV670	FIAT	368	HA5029	CITROËN	225, 229, 233, 271	
GT270	FIAT	324	GV671	FIAT	360, 368, 382		FORD	431, 441	
GT300	FIAT	328	GV680	ALFA ROMEO	14, 16, 18		MAZDA	635	
GT340	ALFA ROMEO	6, 12, 14		FIAT	320, 322, 336, 348, 350, 360, 370, 372, 374, 376, 386, 388, 390, 394, 396, 406		PEUGEOT	929, 935, 939, 947, 975	
GT350	ALFA ROMEO	8, 26		LANCIA	586, 588		SUZUKI	1225	
GT351	ALFA ROMEO	8, 42	GV830	HONDA	480	HA5030	CITROËN	217, 233, 235, 273	
GT360	ALFA ROMEO	8	GV990	NISSAN	814		FORD	433, 439, 441	
GT370	ALFA ROMEO	26	GW260	ALFA ROMEO	10, 28		MAZDA	635	
GT380	ALFA ROMEO	28	GW261	ALFA ROMEO	28, 44		MINI	737	
GT400	FIAT	404	GW280	ALFA ROMEO	10, 26		PEUGEOT	937, 939, 947, 961, 977	
GT401	FIAT	368	GW281	ALFA ROMEO	40, 42		RENAULT	1093	
GT410	FIAT	328	GW282	ALFA ROMEO	40, 42	HA5031	CITROËN	217, 233, 235, 273	
	LANCIA	584	GW300	ALFA ROMEO	10, 12		FORD	433, 439, 441	
GT411	LANCIA	586, 596	GW301	ALFA ROMEO	20		MAZDA	635	
GT423	LANCIA	586, 590		FIAT	330		MINI	737	
GT430	NISSAN	742, 754, 756, 760	GW321	FIAT	324, 326, 356		PEUGEOT	937, 939, 947, 961, 977	
GT431	NISSAN	756, 760	GW341	FIAT	356		RENAULT	1093	
GT440	FIAT	328, 390, 394		LANCIA	592	HA5032	CITROËN	217, 229, 233, 273	
	LANCIA	586	GW410	ALFA ROMEO	18, 20, 26		PEUGEOT	937, 939, 947, 975, 987	
GT441	LANCIA	598	GW420	NISSAN	784, 808, 818	HA5034	SMART	1201	
GT442	LANCIA	598	GW421	NISSAN	784, 808, 818		HA5040	VOLVO	1397, 1415, 1431
GT444	FIAT	328, 394	GW540	NISSAN	788, 804, 820			1397, 1399, 1403, 1405, 1407, 1413, 1415, 1417, 1419, 1421, 1423, 1431, 1433, 1435, 1437, 1439, 1441	
GT445	FIAT	328	GW560	TOYOTA	1282	HA5042	VOLVO	1401, 1403, 1425, 1439, 1441	
GT446	FIAT	348, 388, 392, 394	GW620	NISSAN	790, 792, 796, 800				
	LANCIA	586	GW711	ALFA ROMEO	14, 16, 22, 40	HA5001	FORD	415, 417, 419, 429, 431, 451, 453, 463	
GT447	ALFA ROMEO	20	GW712	ALFA ROMEO	14, 16, 22, 28, 40, 42		HBS002	BEDFORD	111
	FIAT	326	GW713	ALFA ROMEO	14, 16, 20, 40, 42			DAEWOO	291, 293, 295, 297
	LANCIA	590	GW721	ALFA ROMEO	12, 14, 18, 22, 42			OPEL	829, 831, 833, 835, 837, 839, 847, 849, 851, 853, 855, 857, 861, 863, 865, 869, 885, 887
GT448	FIAT	326, 396	GW722	ALFA ROMEO	12, 14, 18, 20, 22, 38, 40, 42	HA5012	CITROËN	247, 261, 267, 269	
	LANCIA	586, 588, 590, 596	GW723	FIAT	318, 320, 322, 326, 354, 370		LANCIA	607	
GT449	FIAT	390, 394, 396		LANCIA	584, 588, 592	HA5005	LANCIA	585, 589, 593	
	LANCIA	584, 586, 588	GW724	ALFA ROMEO	18, 20, 42	HA5006	LAND ROVER	615	
GT510	FORD	462, 466, 472		FIAT	318, 322, 354		MG	731	
GT630	TOYOTA	1264, 1276, 1278, 1280	GW800	TOYOTA	1278, 1280, 1284, 1286, 1288	HA5008	CITROËN	219, 229, 243, 251, 275	
GT750	FIAT	330	GW801	TOYOTA	1280, 1282, 1284, 1286, 1308		FIAT	379	
	LANCIA	598	GW950	TOYOTA	1284, 1288, 1308		PEUGEOT	937, 943, 981, 989	
GT751	LANCIA	598, 600	GX010	TOYOTA	1258, 1270, 1272, 1292, 1306		TOYOTA	1275	
GT880	NISSAN	750, 754	GX020	TOYOTA	1254, 1260, 1308	HA5010	JAGUAR	553, 555, 557	
GT890	NISSAN	740, 742, 758	GX030	FIAT	318, 354, 358, 360	HA5011	JAGUAR	553, 555, 557	
	PROTON	990		LANCIA	584, 592	HA5015	JEEP	569	
GT900	SUZUKI	1224, 1226	GX041	FIAT	318, 322, 352	HA5016	JEEP	569	
GV020	HONDA	486, 488, 492		LANCIA	602	HA5020	FORD	449, 471	
GV021	HONDA	496	GX060	TOYOTA	1284	HA5023	BMW	133, 135, 137, 141, 143, 147, 149, 151, 157, 161, 163, 169, 171, 173, 175	
GV030	HONDA	480, 498	GX390	CITROËN	248, 250, 256			121, 123, 125, 129, 133, 167, 173	
	ROVER	1112		FIAT	346	HA5028	CITROËN	213, 215, 229, 231, 259, 271, 281	
GV110	KIA	574	GX391	FIAT	346		PEUGEOT	925, 927, 931, 935, 941, 947, 987	
	MAZDA	642		IVECO	536, 542				
GV250	NISSAN	790, 802							
GV311	NISSAN	780, 784, 790, 792, 796, 800, 802, 820							
GV330	TOYOTA	1268, 1296, 1306							
GV360	TOYOTA	1256, 1260, 1270							
GV380	MAZDA	644, 656							
GV431	KIA	574							
	MAZDA	636, 638, 640, 654							
GV440	NISSAN	780, 782, 806, 808, 812, 816, 820							
GV540	NISSAN	780, 796, 808, 818							
GV541	NISSAN	808							









							
HBS010	JEEP 563, 565 RENAULT 1033, 1035, 1041, 1051, 1071, 1077, 1079, 1083, 1091	HBS035	LADA 579 OPEL 843, 845, 867, 889, 891 VAUXHALL 1335, 1341, 1351	HBS053	DAEWOO 291 OPEL 845, 859, 875 VAUXHALL 1331, 1335, 1357, 1367	HBS077	FORD 443, 445 MERCEDES-BENZ 721 VW 1463, 1487, 1517, 1539, 1547, 1553
HBS011	ALFA ROMEO 35, 37 FIAT 319, 325, 331, 341, 343, 345, 347, 357 IVECO 535, 537, 539, 541, 543, 545, 547, 549 LANCIA 599, 601 OPEL 829, 873 RENAULT 1051, 1053, 1083, 1091 VAUXHALL 1321, 1363	HBS036	HONDA 491 ISUZU 525, 527, 529 MAZDA 643 OPEL 839, 841, 849, 855, 857, 863, 871, 887 VAUXHALL 1325, 1329, 1331, 1337, 1339, 1349, 1353, 1355, 1357, 1361, 1365, 1367, 1375	HBS054	CHEVROLET 179, 181 DAEWOO 291, 293, 295, 297 LADA 579 OPEL 841, 843, 845, 859, 867, 875, 883, 889, 891, 897 VAUXHALL 1331, 1333, 1335, 1341, 1351, 1357, 1359, 1367, 1371, 1375, 1377, 1379, 1381	HBS078	FORD 427, 429, 431, 433, 437, 439, 441, 457 MAZDA 635, 637
HBS015	FORD 461, 467 PEUGEOT 965, 967, 985 TALBOT 1243	HBS038	CITROËN 221, 223, 225, 231, 263, 265, 281, 283 FIAT 339 PEUGEOT 933, 935, 939, 941, 951, 953, 955, 957, 963, 965, 983, 985	HBS055	OPEL 835, 837, 839, 841, 849, 853, 855, 857, 869, 871, 881, 885, 887, 889, 895 SAAB 1131 VAUXHALL 1323, 1325, 1327, 1329, 1331, 1355, 1357, 1359, 1361, 1373, 1375, 1379	HBS082	CITROËN 215, 279 PEUGEOT 927 ROVER 1103
HBS016	FORD 445, 459, 461 LEYLAND / LDV 623, 625 PEUGEOT 965, 967, 985	HBS039	CITROËN 213, 215, 217, 219, 221, 225, 227, 229, 231, 257, 259, 271, 273, 279, 281 PEUGEOT 925, 927, 929, 931, 935, 937, 941, 947, 949, 953, 975, 977, 985, 987	HBS056	FORD 413, 427, 445, 457, 459, 463, 465, 467, 469, 471	HBS083	CITROËN 221, 223, 263, 281, 283 PEUGEOT 933, 935, 939, 941, 951, 953, 955, 957
HBS017	CITROËN 231, 233, 241 FIAT 317 PEUGEOT 985	HBS041	BMW 131, 133, 137, 147, 149, 151, 171	HBS057	FORD 459, 463, 467, 473	HBS084	CITROËN 217, 219, 223, 225, 227, 229, 231, 241, 243, 245, 247, 249, 251, 255, 261, 265, 267, 269, 273, 275, 277, 281, 283 FIAT 335, 339, 379, 399, 401 HONDA 491 HYUNDAI 509 LADA 579 LANCIA 607 LEYLAND / LDV 623, 625 PEUGEOT 933, 935, 937, 941, 943, 945, 947, 951, 953, 955, 957, 959, 961, 967, 969, 971, 973, 977, 979, 981, 983, 987, 989 ROVER 1107, 1111 SUZUKI 1227, 1231 TALBOT 1239
HBS018	AUDI 51, 53, 57, 71, 77, 79, 85, 93 FORD 443 SEAT 1141, 1147, 1153, 1155, 1163, 1165, 1167, 1171, 1173, 1175, 1179, 1181 SKODA 1187, 1189, 1193, 1195 VW 1451, 1453, 1457, 1459, 1461, 1469, 1471, 1477, 1479, 1481, 1483, 1487, 1489, 1491, 1497, 1501, 1505, 1509, 1511, 1521, 1523, 1527, 1529, 1531, 1533, 1537, 1541, 1543, 1551	HBS042	TOYOTA 1251, 1253, 1255, 1259, 1261, 1271, 1273, 1275, 1277, 1293, 1299, 1307, 1309	HBS058	DAEWOO 295 MERCEDES-BENZ 665, 671, 681, 683, 711, 713, 715, 717, 719, 721, 723 SSANGYONG 1205, 1207	HBS086	CITROËN 231 FIAT 339 PEUGEOT 963, 965, 967, 983, 985
HBS021	AUDI 61, 65, 89 VOLVO 1399, 1419, 1423, 1437 VW 1493, 1543, 1545	HBS043	AUDI 51, 53, 55, 59, 61, 73, 85, 93, 95, 97 SEAT 1143, 1149, 1151, 1153, 1155, 1157, 1159, 1161, 1163, 1167, 1169, 1177, 1179, 1181 VW 1457, 1459, 1463, 1465, 1467, 1469, 1471, 1473, 1475, 1477, 1485, 1487, 1489, 1491, 1501, 1503, 1507, 1509, 1513, 1517, 1519, 1521, 1525, 1533, 1535, 1537, 1541, 1547, 1549, 1551	HBS059	DAEWOO 293, 295 MERCEDES-BENZ 667, 687, 689, 697, 701, 713, 715, 717, 719 SSANGYONG 1205, 1207	HBS087	CITROËN 245, 261, 267, 269, 277, 283, 285 FIAT 399 LANCIA 605 PEUGEOT 945, 957, 959, 967, 973
HBS022	VOLVO 1385, 1395, 1397, 1401 VW 1493, 1495	HBS044	SEAT 1157, 1161, 1175	HBS060	MERCEDES-BENZ 691, 693, 697, 699, 705	HBS088	CITROËN 243, 245, 247, 253, 255, 261, 267, 277, 283 FIAT 337, 339, 379, 397 PEUGEOT 945, 957, 959, 971, 977, 981
HBS024	AUDI 55, 57, 59, 61, 63, 65, 67, 87, 93, 95, 97, 99 VW 1513, 1515, 1533	HBS045	MERCEDES-BENZ 665, 681, 687, 697, 699, 715, 717, 719	HBS061	MERCEDES-BENZ 671, 673, 683, 685	HBS089	CITROËN 265, 275, 283 PEUGEOT 943, 957
HBS028	AUDI 55, 63, 85, 93 SEAT 1153, 1157, 1165, 1167, 1177, 1183 VW 1461, 1463, 1475, 1485, 1491, 1509, 1513, 1535, 1551	HBS046	MERCEDES-BENZ 689, 697, 703, 715	HBS062	MERCEDES-BENZ 673, 675, 687	HBS092	ALFA ROMEO 27 FIAT 329, 331, 377, 389, 391, 393, 395, 397 LANCIA 585, 587, 589, 591, 599
HBS029	VW 1465, 1487	HBS047	MERCEDES-BENZ 665, 681, 683, 685, 697, 715	HBS063	MERCEDES-BENZ 693, 699, 703	HBS093	ALFA ROMEO 21 FIAT 327, 329, 391, 395, 397 LANCIA 587, 589, 591, 597, 599
HBS031	FORD 413, 417, 419, 421, 431, 433, 439, 441, 445, 447, 449, 453, 469, 475 MAZDA 657	HBS050	FORD 415, 427, 429, 445, 451 MAZDA 637	HBS064	AUDI 57, 65, 81, 89, 91, 93, 99	HBS095	ALFA ROMEO 15, 17, 19, 35 FIAT 321, 323, 337, 349, 351, 361, 371, 373, 375, 377, 387, 389, 391, 395, 397, 405, 407 LANCIA 587, 589, 597
HBS032	FORD 427, 443, 459, 465, 467, 471	HBS051	CITROËN 241, 251 FIAT 347, 349, 351, 361, 367, 369, 373, 375, 377, 383, 387, 389, 393, 403, 405, 407 LANCIA 585, 587, 589, 597 PEUGEOT 979 ZASTAVA 1555	HBS065	BMW 137, 149	HBS097	FIAT 329
HBS033	FORD 421, 423, 425, 435, 437, 449, 455, 457, 465 MAZDA 639	HBS052	FIAT 327, 333, 353, 359, 361, 363, 365, 367, 369, 381, 383, 387, 393, 403 LANCIA 595, 601, 603, 605	HBS066	BMW 139, 141, 143, 153, 155, 157, 161, 163, 169, 171 LAND ROVER 615, 617 OPEL 877 VAUXHALL 1369		
				HBS067	BMW 135, 137, 141, 147, 149, 151, 157, 159, 161, 163, 165, 167, 171, 173		
				HBS068	BMW 131, 133, 135, 137, 141, 147, 149, 151, 157, 161, 173		
				HBS069	BMW 123, 125, 127, 145, 171		
				HBS070	BMW 123, 125, 145		
				HBS071	BMW 149, 155, 157, 159, 161, 163, 165		
				HBS074	BEDFORD 111, 113 OPEL 831, 839, 841, 865, 887 VAUXHALL 1327, 1329, 1331, 1337, 1339, 1347		
				HBS075	SEAT 1145, 1149, 1151, 1159, 1163, 1169 SKODA 1189, 1191 VW 1457, 1465, 1469, 1521, 1523, 1527, 1547		

											
HBS263	ALFA ROMEO	15	HBS288	FORD	457	HBS310	NISSAN	807	HBS369	FORD	437, 439, 441, 447, 449, 471
HBS264	AUDI	67		MAZDA	649, 651, 655		OPEL	895		MAZDA	635, 637, 655
	SEAT	1145, 1149, 1159	HBS289	MAZDA	645, 647, 657		RENAULT	1025, 1031, 1033, 1043, 1045, 1047, 1049, 1057, 1059, 1085, 1087, 1091, 1093		VOLVO	1409, 1429
	SKODA	1187, 1197	HBS291	MERCEDES-BENZ	667, 719	HBS292	CHRYSLER	187	HBS370	ALFA ROMEO	19, 23, 25, 27, 39
	VW	1465, 1497, 1523		MERCEDES-BENZ 671, 673, 679, 683, 685, 711, 719, 721			VAUXHALL	1379		FIAT	325, 329, 385
HBS265	AUDI	81, 87, 89, 90, 91	HBS293	JEEP	567	HBS311	AUDI	67		OPEL	841, 881, 889, 897
	ISUZU	527		MERCEDES-BENZ 675, 679, 689, 697, 701, 712, 713			VW	1497		SAAB	1131, 1133
	SKODA	1199	HBS294	MERCEDES-BENZ	695, 703	HBS312	DAIHATSU	307, 309, 311		VAUXHALL	1333, 1337, 1371, 1375, 1379
	VW	1515	HBS295	HYUNDAI	507, 509, 513		TOYOTA	1309, 1311	HBS371	ALFA ROMEO	23, 25, 27, 31
HBS268	AUDI	69, 75, 83, 101	HBS296	FORD	449, 471	HBS313	TOYOTA	1301, 1309, 1311		FIAT	331
	SEAT	1141, 1153, 1165, 1173, 1177	HBS297	FIAT	327, 363, 381	HBS314	TOYOTA	1251, 1275, 1277, 1299, 1301, 1307		LANCIA	601
	SKODA	1191, 1197	HBS298	OPEL	843, 845, 859, 875, 881, 883, 889, 891, 893, 897	HBS315	TOYOTA	1279, 1281, 1283, 1285, 1287, 1289, 1309	HBS372	OPEL	895
	VW	1449, 1475, 1477, 1499, 1509, 1529, 1535		SAAB	1133	HBS316	AUDI	67		RENAULT	1031, 1043, 1047, 1051, 1057, 1085, 1089
HBS269	AUDI	55, 57, 63, 65, 87, 97, 99	HBS299	DACIA	287		SEAT	1171, 1177		VAUXHALL	1361
HBS270	AUDI	79, 87		NISSAN	783, 795, 799, 801, 811	HBS349	SMART	1201	HBS373	NISSAN	795, 807, 811
HBS272	CITROËN	237, 239, 269, 271		RENAULT	1027, 1029, 1041, 1043, 1055, 1061, 1083, 1085, 1087	HBS353	FIAT	333, 351, 353, 361, 367, 369, 387		OPEL	873, 895
	FIAT	401	HBS300	AUDI	69, 71, 77, 79, 83		LANCIA	595, 605		RENAULT	1025, 1035, 1049, 1051, 1091, 1093
	LANCIA	593, 597, 601		FORD	443		OPEL	829, 833, 847, 853, 883	HBS374	NISSAN	785, 805, 811, 823
	PEUGEOT	961, 963, 969, 971, 975		HONDA	485	HBS354	HYUNDAI	511, 513	HBS377	CHEVROLET	179, 181
	RENAULT	1025, 1031, 1035, 1049, 1051, 1083		SEAT	1141, 1143, 1155, 1165, 1167, 1173, 1179, 1181		KIA	575	HBS378	DAEWOO	295, 299
HBS273	CITROËN	249, 257		SKODA	1187, 1193, 1195, 1197	HBS358	FORD	429, 445	HBS379	HYUNDAI	503, 507
	PEUGEOT	979		VW	1453, 1459, 1461, 1463, 1481, 1483, 1485, 1491, 1497, 1499, 1511, 1515, 1531, 1535, 1537, 1539, 1541, 1543	HBS359	CITROËN	217, 225, 229, 233, 235, 271, 273		KIA	575
HBS277	CITROËN	243, 245, 247, 253, 255, 261, 267, 277, 283	HBS301	RENAULT	1027, 1029, 1041, 1045, 1053, 1055, 1057, 1061, 1083, 1085, 1087		FORD	431, 433, 439, 441	HBS381	HYUNDAI	513
	FIAT	337, 339, 379, 397	HBS302	PEUGEOT	965	HBS358	MAZDA	635		KIA	573, 577
	PEUGEOT	945, 957, 959, 971, 977, 981	HBS303	VOLVO	1397, 1399, 1403, 1405, 1407, 1413, 1415, 1417, 1419, 1421, 1431, 1433, 1435, 1437, 1439		MINI	737	HBS382	HYUNDAI	505, 511, 513
	SUZUKI	1221, 1227, 1231	HBS305	LAND ROVER	613	HBS359	PEUGEOT	929, 935, 937, 939, 947, 961, 975, 977		KIA	573, 577
HBS278	CITROËN	245, 261, 267, 269, 277, 283, 285	HBS306	TOYOTA	1267, 1283, 1297, 1305		SUZUKI	1225	HBS385	TOYOTA	1251, 1261, 1267, 1269, 1271, 1273, 1295, 1301
	FIAT	399	HBS307	HYUNDAI	511, 513	HBS360	SEAT	1149, 1159	HBS386	TOYOTA	1249, 1287, 1289
	LANCIA	605	HBS308	HYUNDAI	503, 505, 509		TOYOTA	1225		VW	1539
	PEUGEOT	945, 957, 959, 967, 973	HBS309	CITROËN	239	HBS361	AUDI	81, 87, 89, 91, 99	HBS387	HYUNDAI	503, 507, 509, 511
HBS279	CHRYSLER	185, 187, 189		PEUGEOT	965		SKODA	1199	HBS391	CHRYSLER	185, 187, 189
HBS280	CHRYSLER	189		RENAULT	1081, 1083	HBS362	VW	1515, 1517, 1539	HBS392	FORD	413, 451
	JEEP	565	HBS305	LAND ROVER	613		SEAT	1145, 1147, 1157, 1159, 1169	HBS394	LEXUS	619
HBS281	HONDA	479, 481, 495, 499	HBS306	TOYOTA	1267, 1283, 1297, 1305	HBS363	VW	1455, 1495, 1497, 1517, 1521		TOYOTA	1249, 1255, 1291
HBS282	HONDA	479, 491	HBS307	HYUNDAI	511, 513		VAUXHALL	1455, 1495, 1497, 1517, 1521	HBS397	TOYOTA	1249
	LAND ROVER	615	HBS308	HYUNDAI	503, 505, 509	HBS364	AUDI	73, 79, 85	HBS402	CHRYSLER	185
	MG	729	HBS309	CITROËN	239		MITSUBISHI	751		HYUNDAI	507, 513
	ROVER	1097, 1099, 1109, 1113, 1121		PEUGEOT	961, 963, 971, 975		SEAT	1143, 1175, 1181	HBS404	NISSAN	781, 783, 797, 801, 805, 821
HBS283	NISSAN	795					SKODA	1195	HBS405	SUBARU	1211, 1213, 1215
	RENAULT	1026, 1027, 1043, 1059, 1091	HBS302	PEUGEOT	965	HBS366	FORD	439	HBS406	KIA	575, 577
HBS284	HONDA	479, 481, 497, 499	HBS303	VOLVO	1397, 1399, 1403, 1405, 1407, 1413, 1415, 1417, 1419, 1421, 1431, 1433, 1435, 1437, 1439					MAZDA	637, 639, 641, 643, 645, 651, 653, 655, 657
	ROVER	1113	HBS305	LAND ROVER	613				HBS407	SUZUKI	1227
HBS285	CHEVROLET	179, 181	HBS306	TOYOTA	1267, 1283, 1297, 1305				HBS408	SUZUKI	1227
	DAEWOO	291, 293, 295, 297	HBS307	HYUNDAI	511, 513				HBS409	NISSAN	791, 807, 815, 817
HBS286	ISUZU	521, 527, 529	HBS308	HYUNDAI	503, 505, 509				HBS413	BMW	131, 133, 137, 143, 147, 149, 151, 157, 163, 169, 171, 173, 175
	OPEL	847	HBS309	CITROËN	239				HBS415	FORD	457
	VAUXHALL	1341		PEUGEOT	961, 963, 971, 975						
HBS287	ISUZU	521, 523, 529									
	OPEL	847, 859, 871									
	VAUXHALL	1359									

NUMERICAL PARTS LIST









Numerische Teilenummernliste • Liste des références produits
Lista de referencias









							
HBS416	ALFA ROMEO 25, 27 CHEVROLET 179, 181 FIAT 331 OPEL 845, 881, 883, 889, 891, 893, 897 SAAB 1131 VAUXHALL 1335, 1371, 1377, 1379, 1381	HBS465	ALFA ROMEO 25, 27 FIAT 329	HC354	DACIA 287 RENAULT 1041, 1061, 1063, 1069, 1081, 1089 VOLVO 1385, 1387	HJ013	AUSTIN 105, 107, 109 MG 727, 733 MORRIS 775 ROVER 1119
HBS417	OPEL 877, 881 VAUXHALL 1345, 1369	HBS466	AUDI 73, 101 VW 1463, 1487, 1499, 1517, 1539, 1547	HC355	FORD 415, 427	HJ271	FIAT 341, 343 IVECO 535, 537, 539, 541, 543, 545, 547, 549 RENAULT 1053, 1091
HBS418	HYUNDAI 511, 513	HBS467	BMW 121, 123, 125, 129, 133, 167, 173	HC375	RENAULT 1061	HJ274	FIAT 349, 363, 365, 367, 401, 405 LANCIA 603
HBS419	OPEL 871 VAUXHALL 1361	HBS468	BMW 121, 135, 139, 142, 143, 145, 153, 161, 163, 169, 173, 175	HC417	BEDFORD 113 OPEL 869, 871, 875, 877, 879, 881 VAUXHALL 1343, 1345, 1369	HJ277	FIAT 375 LANCIA 589
HBS420	MAZDA 641	HBS471	SEAT 1147, 1157 SKODA 1187, 1195 VW 1519	HC418	FORD 413, 445, 467	HJ279	FIAT 349, 351, 373, 375, 403, 405
HBS421	MITSUBISHI 749, 759, 761, 769, 771 PROTON 991	HBS474	CHRYSLER 185 JEEP 567 MERCEDES-BENZ 675, 679, 681, 691, 697, 699, 701, 703	HC425	JAGUAR 553, 555	HJ280	FIAT 363, 365, 367, 381, 393, 403 LANCIA 603
HBS422	NISSAN 783, 807, 809	HBS477	MITSUBISHI 743, 757, 769 PROTON 991	HC440	FORD 415, 417, 419, 429, 431, 451	HJ282	FIAT 319, 323, 355, 359, 361, 393
HBS423	KIA 573 LAND ROVER 615 MG 731 ROVER 1099, 1101, 1117	HBS478	KIA 573, 575, 577	HC442	NISSAN 791, 793, 795, 807, 811, 815, 817 799	HJ283	ALFA ROMEO 13, 15, 19, 21, 23, 39, 41, 43 FIAT 319, 327, 355, 357, 371, 387, 389, 391, 395, 397 LANCIA 587, 589, 591, 595
HBS425	TOYOTA 1249, 1283, 1285, 1299	HBS479	SKODA 1187 VW 1463, 1519	HC443	NISSAN 799	HJ287	ALFA ROMEO 7, 13 NISSAN 791
HBS426	VOLVO 1403, 1425, 1439, 1441	HBS483	HYUNDAI 503, 507, 509 KIA 573, 575	HC451	FORD 471, 473	HJ291	FIAT 363, 381
HBS431	RENAULT 1049, 1059	HC016	TRIUMPH 1313	HC452	FORD 415, 427, 429, 451	HJ292	FIAT 363
HBS432	FORD 447 NISSAN 805, 807, 819	HC027	FIAT 349, 363, 365, 401 SEAT 1157, 1175	HC458	NISSAN 817	HL196	MERCEDES-BENZ 687, 689, 703, 705
HBS433	NISSAN 803	HC031	AUSTIN 105, 107, 109 MG 727, 733 MORRIS 775 ROVER 1119	HC459	NISSAN 781, 787, 789, 807, 811, 813, 815, 817, 819	HL442	CITROËN 221, 227, 255, 263 PEUGEOT 923, 925, 929, 931 TALBOT 1241
HBS434	HYUNDAI 507 KIA 577	HC048	AUSTIN 105 MG 733 MORRIS 775	HC5004	FORD 449, 471	HL456	VW 1487
HBS435	HYUNDAI 503 KIA 575	HC059	BEDFORD 113	HC5005	MERCEDES-BENZ 672, 684	HL457	AUDI 51, 53, 55, 57, 59, 61, 93, 95, 97 SEAT 1151, 1153, 1161, 1163, 1169, 1177, 1179 VW 1457, 1459, 1467, 1469, 1471, 1473, 1475, 1477, 1487, 1489, 1491, 1501, 1503, 1505, 1507, 1509, 1525, 1533, 1535, 1541, 1543, 1549
HBS436	KIA 575	HC060	FORD 413, 419 LOTUS 631	HC5007	DAEWOO 292, 296 OPEL 840, 842, 844, 874, 888, 890 VAUXHALL 1332, 1340, 1350, 1366, 1374, 1376	HL460	AUDI 57, 59, 61, 63, 65, 67, 95, 97, 99 VW 1513, 1515, 1533
HBS438	JEEP 565, 567, 569	HC063	AUSTIN 105 MG 733	HC5008	ISUZU 521, 529 OPEL 847, 859, 871, 877, 881 VAUXHALL 1345, 1359, 1369	HL462	AUDI 61
HBS439	JEEP 569	HC070	FORD 413, 419	HC5009	KIA 573, 575, 577 MAZDA 639, 641, 655, 657	HL463	AUDI 61
HBS440	HYUNDAI 505, 509, 511 MITSUBISHI 743, 755, 757	HC259	NISSAN 785, 791, 815, 821	HC5010	NISSAN 799	HL469	VOLVO 1385, 1395, 1397, 1399, 1401 VW 1493
HBS441	TOYOTA 1251, 1253, 1255, 1299, 1301	HC285	FORD 413, 419, 427, 445, 457, 459, 463, 465, 467, 469, 471	HC5011	NISSAN 785, 809, 819	HL472	CITROËN 231 FIAT 339 PEUGEOT 963, 965, 967, 983, 985
HBS443	NISSAN 801	HC288	OPEL 851, 861, 869 VAUXHALL 1321, 1363	HG034	NISSAN 785, 791, 815, 821	HL474	FORD 417, 433, 453
HBS445	LEXUS 619	HC295	OPEL 871, 877, 881 VAUXHALL 1345, 1369	HG037	NISSAN 781, 785, 787, 789, 791, 793, 795, 797, 801	HL478	SUBARU 1215
HBS446	HYUNDAI 505, 511, 513, 515 KIA 575	HC326	FORD 471	HG087	CITROËN 221, 225, 255, 263 PEUGEOT 923, 929 TALBOT 1241	HL502	MITSUBISHI 745, 749, 759, 771, 773
HBS447	SUZUKI 1223, 1231	HC341	CITROËN 225, 227 PEUGEOT 929, 931, 949 TALBOT 1237, 1239, 1241, 1243	HG088	PEUGEOT 939	HL508	MAZDA 639, 641, 653
HBS450	LEXUS 619 TOYOTA 1305	HC346	FORD 445, 459, 461 LEYLAND / LDV 623, 625 PEUGEOT 963, 965, 967, 985 SSANGYONG 1205 TALBOT 1243	HG092	CITROËN 221 PEUGEOT 925, 931	HL509	MAZDA 649, 651, 655
HBS452	TOYOTA 1293	HC361	FORD 471	HG104	CITROËN 221, 225, 263 PEUGEOT 923, 929 TALBOT 1241	HL510	TOYOTA 1279, 1281, 1289
HBS454	HYUNDAI 503, 505, 507, 509, 513	HC374	PEUGEOT 963, 965	HG108	CITROËN 221, 255, 263 PEUGEOT 923, 925, 929, 931 TALBOT 1241		
HBS455	KIA 575, 577						
HBS457	MERCEDES-BENZ 667, 669						
HBS458	MERCEDES-BENZ 667, 669						
HBS459	MERCEDES-BENZ 669, 677, 681, 709						
HBS460	SMART 1201						
HBS461	SEAT 1183 VW 1453, 1485, 1515						
HBS463	LANCIA 601 MERCEDES-BENZ 673, 675, 679, 687, 689, 695, 699, 701, 703, 705, 707, 709, 721, 723						
HBS464	IVECO 545						

							
HL532	BEDFORD 113 ISUZU 521, 529, 531 OPEL 847 VAUXHALL 1341, 1361	HL5011	CITROËN 213, 215, 217, 219, 221, 227, 229, 231, 257, 259, 271, 273, 279, 281 NISSAN 799 PEUGEOT 925, 927, 929, 931, 935, 937, 941, 947, 949, 953, 975, 985, 987 ROVER 1103	HL5020	AUDI 51, 53, 55, 57, 59, 61, 63, 73, 75, 77, 79, 85, 91, 93, 95, 97 SEAT 1141, 1143, 1145, 1147, 1149, 1151, 1153, 1155, 1157, 1159, 1161, 1163, 1165, 1167, 1169, 1171, 1175, 1177, 1179, 1181, 1183 SKODA 1189, 1191 VW 1455, 1457, 1459, 1461, 1463, 1465, 1467, 1469, 1471, 1473, 1475, 1477, 1479, 1483, 1485, 1487, 1489, 1491, 1495, 1497, 1501, 1503, 1505, 1507, 1509, 1511, 1513, 1517, 1519, 1521, 1523, 1525, 1527, 1529, 1531, 1533, 1535, 1537, 1541, 1543, 1547, 1549, 1551	HL5034	AUDI 67, 69, 73, 77, 79, 83, 85 HONDA 485 SEAT 1141, 1143, 1145, 1149, 1151, 1153, 1155, 1159, 1161, 1165, 1167, 1171, 1173, 1175, 1177, 1179, 1181 SKODA 1187, 1189, 1191, 1193, 1195, 1197 VW 1449, 1453, 1457, 1459, 1461, 1467, 1469, 1481, 1483, 1485, 1489, 1491, 1493, 1497, 1499, 1501, 1503, 1511, 1513, 1515, 1523, 1525, 1531, 1535, 1537, 1539, 1541, 1543
HL606	AUDI 55, 63, 85, 93, 97 SEAT 1153, 1157, 1165, 1167, 1177, 1183 VW 1461, 1463, 1475, 1485, 1491, 1509, 1513, 1535	HL5012	CITROËN 217, 219, 229, 241, 243, 245, 247, 251, 253, 255, 261, 265, 267, 273, 275, 277, 281, 283 PEUGEOT 935, 937, 941, 943, 945, 955, 957, 959, 971, 977, 981, 987, 989	HL5021	RENAULT 1025, 1043, 1091	HL5035	RENAULT 1025, 1035, 1049, 1051, 1093
HL657	MERCEDES-BENZ 688, 690, 692, 698, 702, 704, 706	HL5013	RENAULT 1029, 1031, 1033, 1037, 1039, 1041, 1045, 1047, 1057, 1059, 1065, 1067, 1069, 1073, 1075, 1081, 1087, 1089 VOLVO 1391, 1393, 1411, 1429	HL5022	RENAULT 1025, 1043, 1091 CITROËN 231, 241 PEUGEOT 985	HL5036	RENAULT 1026, 1027, 1043, 1059, 1091
HL659	MERCEDES-BENZ 689, 703, 705	HL5014	JEEP 565 PEUGEOT 965 RENAULT 1033, 1035, 1041, 1051, 1071, 1075, 1077, 1079, 1081, 1083, 1091	HL5023	RENAULT 1035, 1049, 1083	HL5037	CITROËN 235, 237 PEUGEOT 946, 947, 963, 972, 973
HL700	ALFA ROMEO 13, 15, 17, 19, 21, 23, 29, 39, 41, 43	HL5015	RENAULT 1025, 1027, 1029, 1037, 1039, 1043, 1055, 1057, 1071, 1081	HL5024	FIAT 327, 359, 361, 363, 365, 367, 369, 381, 383, 387, 403 LANCIA 601, 603, 605	HL5038	CITROËN 217, 228, 229, 233, 259, 273 PEUGEOT 927, 937, 939, 947, 975, 987
HL701	FIAT 319, 321, 323, 327, 355, 371, 385 LANCIA 585, 593	HL5016	CITROËN 219, 235, 237, 239, 243, 245, 247, 253, 257, 261, 267, 279 FIAT 341, 381, 399, 401 LANCIA 597, 607 PEUGEOT 937, 945, 949, 959, 961, 963, 969, 971, 973, 975, 979, 983, 989 SUZUKI 1223	HL5026	DACIA 287 NISSAN 783, 795, 799, 801, 811 RENAULT 1027, 1029, 1041, 1043, 1055, 1061, 1083, 1085, 1087	HL5039	RENAULT 1031, 1033, 1043, 1045, 1049, 1059, 1087, 1091, 1093
HL702	JAGUAR 553, 555, 557	HL5017	MITSUBISHI 741, 769 NISSAN 795, 807, 809 OPEL 873, 895 RENAULT 1031, 1033, 1043, 1045, 1047, 1051, 1057, 1059, 1085, 1089 VAUXHALL 1361, 1377 VOLVO 1409, 1427	HL5027	CITROËN 249, 257, 271 PEUGEOT 969, 979	HL5040	AUDI 69, 73, 75, 77, 79, 85, 101 SEAT 1141, 1173, 1177 SKODA 1191, 1197 VW 1475, 1477, 1499, 1509, 1513, 1529, 1535
HL728	VOLVO 1397, 1401 VW 1493, 1495	HL5018	FORD 421, 423, 425, 435, 437, 449, 455, 457, 465 MAZDA 639	HL5028	FIAT 391, 395, 397	HM5053	AUDI 51, 53, 55, 57, 59, 61, 93, 95, 97 SEAT 1151, 1153, 1161, 1163, 1169, 1177, 1179 VW 1457, 1459, 1467, 1469, 1471, 1473, 1475, 1477, 1487, 1489, 1491, 1501, 1503, 1505, 1507, 1509, 1525, 1533, 1535, 1541, 1543, 1549
HL730	AUDI 55, 57, 63, 65, 87, 97, 99	HL5019	CITROËN 217, 221, 223, 225, 245, 247, 249, 255, 259, 261, 263, 265, 267, 269, 275, 277, 281, 283, 285 FIAT 339, 397, 399, 401 PEUGEOT 933, 935, 939, 941, 943, 945, 947, 951, 953, 955, 957, 959, 961, 967, 969, 971, 973, 979, 981	HL5029	RENAULT 1027, 1029, 1041, 1045, 1053, 1055, 1057, 1061, 1083, 1085, 1087	HM5057	MERCEDES-BENZ 669, 671, 673, 677, 679, 683, 685, 687, 709, 711, 713, 719, 721, 723 VW 1493
HL731	AUDI 55, 63, 85, 93, 97 SEAT 1157, 1167, 1183 VW 1485, 1513			HL5030	ALFA ROMEO 13, 15, 17, 19, 21, 23, 25, 29, 39, 41, 43 FIAT 319, 321, 323, 325, 327, 355, 357, 371, 385, 387 LANCIA 591, 593, 595	HM5058	AUDI 53 SEAT 1153, 1165, 1171, 1179 SKODA 1189 VW 1459, 1477, 1479, 1509, 1511, 1529, 1531, 1543, 1551
HL732	AUDI 69, 73, 75, 77, 83, 91, 101 SEAT 1141, 1153, 1165, 1173, 1177 SKODA 1191, 1197 VW 1449, 1475, 1477, 1499, 1507, 1509, 1529, 1535			HL5031	ALFA ROMEO 13, 15, 17, 19, 23, 25, 31 FIAT 319, 321, 323, 325, 333, 335, 353, 355, 357, 359, 361, 371, 385, 387 LANCIA 585, 591, 593, 595, 601, 603 OPEL 840, 841, 881, 889, 897 SAAB 1131, 1133 VAUXHALL 1333, 1371, 1375, 1379	HM5061	JAGUAR 553, 557
HL733	BMW 127, 145, 171			HL5032	FIAT 345, 347 RENAULT 1053, 1091	HM5062	SEAT 1145, 1147, 1149, 1151, 1157, 1159, 1161, 1163, 1169 SKODA 1189, 1191 VW 1455, 1457, 1465, 1469, 1517, 1519, 1521, 1523, 1527, 1547
HL734	BMW 131, 137, 147, 149, 151			HL5033	CITROËN 217, 225, 233, 235, 273 FORD 431, 433, 438, 439, 441 MAZDA 635 PEUGEOT 929, 935, 937, 939, 947, 961, 975		
HL735	BMW 131, 135, 137, 141, 147, 149, 151						
HL736	BMW 131, 133, 135, 141, 147, 149, 157, 161, 171, 173						
HL5002	FORD 445 SKODA 1187 SMART 1201 VW 1463, 1519						
HL5010	CITROËN 223, 225, 227, 231, 243, 245, 247, 253, 255, 261, 265, 267, 269, 271, 275, 281, 283 FIAT 339, 379, 397, 401 HONDA 491 LADA 579 PEUGEOT 933, 935, 941, 943, 945, 951, 953, 955, 957, 959, 961, 969, 971, 973, 983 ROVER 1107, 1111 SUZUKI 1221, 1227, 1231 TALBOT 1239						

NUMERICAL PARTS LIST









Numerische Teilenummernliste • Liste des références produits
Lista de referencias









								
HM5064	JEEP	569	HM5264	HYUNDAI	513, 515	HR300	CITROËN	221, 227, 256, 263
HM5066	BMW	159, 165, 167, 171		KIA	577		PEUGEOT	923, 925, 929, 931, 939, 965, 967
HM5067	BMW	159, 165, 167, 171	HM5265	HYUNDAI	505, 511, 513		RENAULT	1069
HM5069	BMW	133, 137, 143, 147, 149, 151, 157, 163, 169, 173, 175	HM5266	HONDA	481, 497, 499		TALBOT	1241, 1243
HM5070	SAAB	1125, 1127, 1129, 1131, 1133	HM5267	HONDA	479, 481, 491, 499	HR336	BEDFORD	113
HM5150	BMW	121, 123	HM5268	NISSAN	781, 785, 791, 793, 797, 801, 803, 821		OPEL	859, 869, 871, 877, 879, 881
HM5160	BMW	121, 125, 129, 133, 167, 173	HM5269	MAZDA	659		VAUXHALL	1345, 1359, 1369
HM5170	MERCEDES-BENZ	671, 673, 685, 711, 719, 721	HM5270	MAZDA	659	HR339	AUSTIN	105, 107, 109
HM5223	AUDI	81, 87, 89, 90, 91	HM5271	mitsubishi	763		MG	727, 733
	SKODA	1199	HM5272	HYUNDAI	503, 505, 511, 513		ROVER	1115, 1117, 1119
	VW	1515	HM5273	TOYOTA	1305	HR340	CITROËN	231, 233, 241
HM5224	AUDI	79, 87	HM5274	JEEP	567		FIAT	317
HM5225	CHRYSLER	185, 189		MERCEDES-BENZ	675, 679, 689, 697, 701, 712, 713		LEYLAND / LDV	623, 625
HM5226	DAEWOO	291, 295	HM5275	HONDA	495		PEUGEOT	985
HM5227	CHEVROLET	181	HM5276	TOYOTA	1251, 1253, 1255, 1259, 1263, 1295, 1299, 1301	HR342	BEDFORD	111
	DAEWOO	293, 297	HM5277	AUDI	55, 57, 59, 61, 63, 65, 67, 95, 97, 99		DAEWOO	291, 293, 295, 297
HM5228	HONDA	487, 489, 491, 493, 495		VW	1513, 1515, 1533		LADA	579
HM5230	mitsubishi	765	HM5278	BMW	135, 145, 169, 173		OPEL	829, 831, 833, 835, 837, 839, 843, 845, 847, 849, 851, 853, 855, 857, 859, 861, 863, 865, 867, 869, 873, 875, 877, 881, 885, 887, 889, 891
HM5231	SUBARU	1217		VAUXHALL	1371		VAUXHALL	1323, 1325, 1327, 1329, 1331, 1333, 1335, 1337, 1339, 1341, 1343, 1345, 1347, 1349, 1351, 1353, 1354, 1355, 1357, 1359, 1363, 1365, 1367, 1369, 1373
HM5232	SUBARU	1217	HM5289	CITROËN	235, 237, 239, 253	HR343	BEDFORD	111, 113
HM5233	SUBARU	1211, 1213		FIAT	379, 397		OPEL	831, 839, 841, 863, 865, 867, 869, 879, 887
HM5234	SUBARU	1211, 1213		FORD	439, 443, 469		VAUXHALL	1327, 1329, 1331, 1337, 1339, 1341, 1343, 1347, 1349
HM5235	TOYOTA	1251		LANCIA	597	HR350	RENAULT	1025, 1035, 1037, 1039, 1061, 1063, 1065, 1067, 1079, 1081
HM5236	FORD	463		PEUGEOT	949, 963, 971, 975, 983		JEEP	563, 565
HM5238	FORD	443, 459, 471		VOLVO	1403, 1411, 1421, 1429, 1431	HR351	RENAULT	1033, 1035, 1041, 1051, 1071, 1077, 1079, 1083, 1091
HM5239	mitsubishi	753, 767, 769, 771	HM5290	NISSAN	787, 795, 811, 823		ALFA ROMEO	13, 15, 17, 19, 21, 23, 29, 39, 41, 43
HM5240	TOYOTA	1293		OPEL	873		FIAT	319, 321, 323, 327, 333, 353, 355, 357, 359, 361, 363, 365, 367, 369, 381, 383, 387, 393, 403
HM5241	TOYOTA	1293		RENAULT	1025, 1035, 1049, 1051, 1093	HR354	ALFA ROMEO	13, 15, 17, 19, 21, 23, 29, 39, 41, 43
HM5242	LEXUS	619		VAUXHALL	1361		FIAT	319, 321, 323, 327, 333, 353, 355, 357, 359, 361, 363, 365, 367, 369, 381, 383, 387, 393, 403
	TOYOTA	1255	HM5291	RENAULT	1043, 1059, 1085, 1089		LANCIA	585, 589, 595, 601, 603, 605
HM5243	LEXUS	619	HM5292	OPEL	883, 893			
	TOYOTA	1265, 1281, 1295, 1303		RENAULT	1035, 1093			
HM5244	mitsubishi	743, 755, 769		SAAB	1135			
HM5245	mitsubishi	751		VAUXHALL	1371, 1377			
HM5246	HONDA	493	HM5293	VOLVO	1395, 1399, 1401			
HM5247	HONDA	497	HM5294	OPEL	847, 877, 883, 893			
HM5248	ACURA	3		VAUXHALL	1343, 1351, 1369, 1371			
	HONDA	495	HR280	BMW	131, 133, 135, 137, 139, 141, 147, 149, 151, 153, 155, 157, 161, 169, 171, 173			
HM5249	HONDA	497		DAEWOO	297			
HM5250	HYUNDAI	503, 507, 509		LAND ROVER	615			
HM5251	HYUNDAI	505		MERCEDES-BENZ	677, 681, 694, 695, 701, 709			
	KIA	573, 577		OPEL	837, 877, 883, 895			
HM5252	SUBARU	1217		SEAT	1147, 1157			
HM5253	SUBARU	1217		SKODA	1187, 1195			
HM5254	SUBARU	1211, 1213		VAUXHALL	1369, 1371			
HM5255	NISSAN	795		VW	1519			
	SUBARU	1213	HR291	BEDFORD	113			
HM5256	SUBARU	1213		OPEL	851, 861, 869			
HM5257	SUBARU	1217		VAUXHALL	1321, 1363			
HM5258	HONDA	499	HR299	JAGUAR	553, 555, 557			
HM5259	HYUNDAI	503						
HM5260	HYUNDAI	505, 509						
HM5261	HYUNDAI	503, 507						
HM5262	HYUNDAI	503						

												
HR564	CITROËN	213, 215, 217, 219, 221, 225, 227, 229, 231, 255, 257, 259, 263, 271, 279, 281	...HR569	VW	1457, 1459, 1461, 1463, 1465, 1467, 1469, 1471, 1473, 1475, 1477, 1479, 1483, 1485, 1487, 1489, 1491, 1501, 1503, 1505, 1507, 1509, 1511, 1513, 1517, 1519, 1521, 1523, 1525, 1529, 1531, 1533, 1535, 1537, 1541, 1543, 1547, 1549, 1551	HR625	AUSTIN	105, 109	HR662	BMW	131, 133, 137, 147, 149, 151, 155, 167, 171	
	PEUGEOT	923, 925, 927, 929, 931, 935, 941, 947, 949, 953, 975, 985, 987		ZASTAVA	1555		LEYLAND / LDV	625		FIAT	325, 341	
	RENAULT	1037, 1039, 1041, 1063, 1065, 1067, 1071, 1075, 1079, 1089		HR571	CITROËN	255, 263	MG	727, 735	HR752	LAND ROVER	615	
	ROVER	1103		PEUGEOT	923, 929		MORRIS	775		LOTUS	631	
	TALBOT	1241		TALBOT	1241		ROVER	1113, 1119		MG	727, 729, 731, 733	
HR565	RENAULT	1041, 1069, 1089		HR573	PEUGEOT	939	HR630	FORD	413, 461, 467	HR754	MERCEDES-BENZ	689, 703, 705
HR566	CITROËN	217, 221, 223, 225, 245, 259, 263, 265, 275, 281, 283		HR574	FIAT	339	HR631	FORD	413, 415, 417, 419, 427, 429, 431, 445, 451, 453, 457, 459, 463, 465, 467, 469, 471	HR756	MERCEDES-BENZ	665, 681, 683, 685, 697, 715, 717, 719
	FIAT	397		PEUGEOT	963, 965, 967, 985		HR632	FORD	413, 419	HR757	MERCEDES-BENZ	665, 671, 681, 683, 711, 713, 715, 717, 719, 721, 723
	PEUGEOT	933, 935, 939, 941, 943, 951, 953, 955, 957, 971, 981		HR596	ALFA ROMEO	15, 17, 19	HR633	FORD	413, 445, 461, 467		SSANGYONG	1205, 1207
HR569	AUDI	51, 53, 55, 57, 59, 61, 65, 77, 79, 85, 89, 93, 95, 97		FIAT	317, 321, 323, 325, 337, 347, 349, 351, 361, 363, 365, 367, 371, 373, 375, 377, 387, 389, 391, 395, 397, 403, 405, 407		HR635	CARBODIES	177	HR758	MERCEDES-BENZ	667, 687, 689, 697, 701, 713, 715, 717, 719
	BMW	123, 125, 145, 149, 157		LANCIA	587, 589, 601		LAND ROVER	611		SSANGYONG	1205, 1207	
	CITROËN	213, 217, 219, 221, 223, 225, 227, 229, 231, 239, 241, 243, 245, 247, 249, 251, 253, 255, 259, 261, 265, 267, 269, 273, 275, 277, 279, 281, 283		ZASTAVA	1555		LEYLAND / LDV	629	HR641	VOLVO	1385, 1387, 1389, 1393, 1395, 1397, 1399, 1401	
	FIAT	329, 331, 335, 337, 339, 379, 397		HR599	FIAT	317, 327, 333, 349, 361, 363, 365, 367, 369, 381, 383, 387, 389, 393, 401, 403		HR642	CITROËN	213, 215, 217, 219, 221, 225, 227, 229, 231, 249, 257, 259, 267, 271, 273, 279, 281, 283		
	FORD	443		LANCIA	601, 603		HR643	RENAULT	1025, 1035, 1037, 1039, 1063, 1065, 1067, 1071, 1075, 1079, 1089, 1091	HR759	MERCEDES-BENZ	689, 691, 693, 701, 703, 705, 707
	HONDA	491		SEAT	1157		ROVER	1103	HR760	MERCEDES-BENZ	691, 693, 697, 699, 705	
	JEEP	563, 565, 569		HR602	ALFA ROMEO	7, 33, 35, 37	HR644	BMW	123, 125, 127, 133, 145, 171	HR767	INFINITI	517
	LADA	579, 581		AUDI	81, 89, 91, 99		DACIA	287	HR768	NISSAN	781, 797, 809, 819	
	LANCIA	607		BMW	167		MITSUBISHI	741, 769	HR781	FIAT	331, 341, 343, 345	
	LEYLAND / LDV	623, 625		CITROËN	249, 251, 257		NISSAN	795, 807, 809		IVECO	535, 537, 541, 543, 547, 549	
	MITSUBISHI	741		FIAT	319, 325, 331, 341, 343, 345, 347, 357		OPEL	873, 895	HR782	ALFA ROMEO	37	
	OPEL	829		IVECO	535, 537, 539, 541, 543, 545, 547, 549		RENAULT	1025, 1027, 1029, 1031, 1033, 1037, 1039, 1043, 1045, 1047, 1051, 1055, 1057, 1059, 1071, 1073, 1081, 1085, 1087, 1089		FIAT	331, 341	
	PEUGEOT	929, 931, 933, 935, 937, 939, 941, 943, 945, 947, 949, 951, 953, 955, 957, 959, 961, 963, 965, 967, 969, 971, 973, 977, 979, 981, 983, 985, 987, 989		LANCIA	599, 601		SAAB	1125, 1127, 1129, 1131, 1133	HR788	CITROËN	249, 257, 271	
	RENAULT	1029, 1031, 1033, 1035, 1037, 1039, 1041, 1045, 1047, 1051, 1057, 1059, 1065, 1067, 1069, 1071, 1073, 1075, 1077, 1079, 1081, 1083, 1089, 1091		NISSAN	791		SEAT	1175		PEUGEOT	969, 979	
	ROVER	1107, 1111		OPEL	873		VAUXHALL	1361, 1377	HR789	RENAULT	1025, 1043, 1087, 1091	
	SEAT	1141, 1151, 1153, 1155, 1157, 1159, 1161, 1163, 1165, 1167, 1169, 1171, 1175, 1177, 1179, 1181		PEUGEOT	979		VOLVO	1409, 1427		RENAULT	1035, 1049, 1075, 1077, 1081, 1083	
	SKODA	1189		RENAULT	1025, 1051, 1053, 1091		HR655	FORD	415, 427, 429, 443, 445, 451, 459, 465, 467, 471		RENAULT	1025
	SUZUKI	1221, 1227, 1231		VAUXHALL	1363		MAZDA	637	HR656	LAND ROVER	613	
	TALBOT	1239		VW	1463, 1487, 1517, 1539, 1547, 1553		HR658	RENAULT	1025, 1027, 1037, 1039, 1071, 1081	HR658	RENAULT	1025, 1027, 1037, 1039, 1071, 1081
	TOYOTA	1275		HR615	AUDI	55, 57, 59, 61, 63, 65, 67, 87, 89, 93, 95, 97, 99		ROVER	1101, 1103, 1105, 1107, 1109, 1111, 1113, 1115, 1119	HR659	FORD	417, 421, 423, 433, 435, 453, 455, 457, 465
	VAUXHALL	1321		VW	1493, 1513, 1515, 1533, 1543, 1545		HR659	FORD	417, 421, 423, 433, 435, 453, 455, 457, 465	HR660	FORD	459, 463, 467, 473
	VOLVO	1387, 1389, 1391, 1393, 1411, 1429		HR618	LEYLAND / LDV	627		HR661	FORD	413, 415, 417, 419, 427, 429, 431, 445, 451, 453, 457, 459, 463, 465, 467, 469, 471		
				MG	733							
				MORRIS	775							
				HR619	AUSTIN	105, 107, 109						
				MG	733							
				MORRIS	775							
				HR621	LEYLAND / LDV	627						
				HR622	AUSTIN	109						
				ROVER	1105							

NUMERICAL PARTS LIST









Numerische Teilenummernliste • Liste des références produits
Lista de referencias









							
HR791	AUDI 67, 69, 71, 73, 79, 85 BMW 157, 159, 163, 165, 167, 171 CHEVROLET 179, 181 DAEWOO 293, 295, 297 MERCEDES-BENZ 667, 673, 678, 685, 698, 699, 700, 704, 705, 706 OPEL 835, 837, 839, 841, 843, 845, 849, 853, 855, 857, 859, 871, 875, 881, 883, 885, 887, 889, 891, 893, 895, 897 SAAB 1133 SEAT 1143, 1145, 1147, 1149, 1151, 1159, 1161, 1169, 1171, 1175, 1177, 1181 SKODA 1187, 1189, 1191, 1195, 1197 VAUXHALL 1323, 1325, 1327, 1329, 1331, 1333, 1335, 1337, 1341, 1351, 1353, 1355, 1357, 1359, 1361, 1367, 1371, 1373, 1375, 1377, 1379, 1381 VW 1449, 1455, 1463, 1467, 1469, 1483, 1485, 1489, 1491, 1493, 1497, 1499, 1505, 1513, 1515, 1521, 1523, 1525, 1539, 1541	HR814 FIAT 319, 321, 353, 359, 367, 369, 383 LANCIA 603, 605 HR815 ALFA ROMEO 29, 43, 45 LANCIA 601 HR816 AUDI 51, 53, 55, 63, 67, 69, 71, 73, 77, 79, 83, 85, 93, 97 FORD 443 HONDA 485 SEAT 1141, 1143, 1145, 1147, 1149, 1151, 1153, 1155, 1157, 1159, 1161, 1163, 1165, 1167, 1169, 1171, 1173, 1177, 1179, 1181, 1183 SKODA 1187, 1189, 1191, 1193, 1195, 1197 VW 1449, 1451, 1453, 1455, 1457, 1459, 1461, 1463, 1465, 1467, 1469, 1471, 1473, 1475, 1477, 1479, 1481, 1483, 1485, 1487, 1491, 1495, 1497, 1499, 1501, 1503, 1507, 1509, 1511, 1513, 1515, 1517, 1519, 1521, 1523, 1525, 1527, 1529, 1531, 1533, 1535, 1537, 1539, 1541, 1543, 1547, 1549, 1551	HR5033 FORD 413, 417, 419, 421, 431, 433, 439, 441, 445, 447, 449, 453, 469, 475 MAZDA 657 HR5044 LAND ROVER 611, 613 HR5045 BMW 121, 129, 131, 149, 165, 167 LAND ROVER 615 MG 731 ROVER 1101 HR5046 CITROËN 219, 235, 237, 239, 243, 245, 247, 249, 253, 257, 261, 267, 279 FIAT 341, 381, 399, 401 LANCIA 597, 607 PEUGEOT 937, 945, 949, 959, 961, 963, 969, 971, 973, 975, 979, 983, 989 SUZUKI 1223 HR5048 OPEL 829, 833, 841, 849, 851, 855, 857, 869, 871, 881, 883, 885, 887, 889, 895 SAAB 1131 VAUXHALL 1321, 1323, 1331, 1353, 1357, 1361, 1373, 1375, 1379	HR5062 AUDI 73, 81, 87, 89, 90, 91, 99, 101 BMW 133, 143, 147, 149, 151, 157, 163, 169, 173, 175 CITROËN 237, 239, 269, 271 FORD 445 LANCIA 597 MERCEDES-BENZ 672, 675, 679, 680, 704 OPEL 847, 877, 883, 893 PEUGEOT 961, 963, 971, 975 SAAB 1127, 1131, 1135 SEAT 1143, 1175, 1183 SKODA 1199 VAUXHALL 1343, 1351, 1369, 1371, 1377 VW 1455, 1463, 1485, 1487, 1499, 1515, 1517, 1539, 1545, 1547 HR5063 FORD 437, 439, 441, 447, 449 MAZDA 637 VOLVO 1409, 1429 HR5064 FIAT 399 FORD 471, 473 LEYLAND / LDV 625 HR5068 AUDI 57, 67, 93 SEAT 1145, 1149, 1159 SKODA 1187, 1197 VW 1465, 1497, 1523 HR5072 SAAB 1131, 1133 HR5075 CHEVROLET 179, 181 DAEWOO 295, 299 HR5076 VOLVO 1403, 1405, 1407, 1409, 1411, 1413, 1415, 1417, 1419, 1421, 1423, 1425, 1427, 1429, 1431, 1433, 1435, 1437, 1439, 1441 HR5077 JEEP 569 HR5080 CITROËN 245, 261, 265, 267, 269, 275, 277, 283, 285 PEUGEOT 943, 945, 957, 959, 967, 973 HR5081 CITROËN 245, 261, 265, 267, 269, 275, 277, 283, 285 PEUGEOT 943, 945, 957, 959, 967, 973 HR5082 FORD 449, 471 HR5085 MERCEDES-BENZ 669, 671, 673, 675, 677, 679, 681, 683, 685, 687, 699, 701, 705, 709, 711, 712, 713, 719, 721, 723 HR5087 OPEL 835, 869, 895 VAUXHALL 1325, 1359, 1379 HR5088 FIAT 333, 353, 367, 369 LANCIA 595, 605 OPEL 829, 833, 847, 853, 883 SUZUKI 1225, 1229, 1233 VAUXHALL 1353, 1373 HR5092 DAEWOO 291, 293, 295, 297			
HR794 OPEL 859, 875, 877, 879, 881 VAUXHALL 1345, 1359	HR800 ALFA ROMEO 7, 13, 15, 17, 19, 25, 29, 31, 39, 41, 45 FIAT 319, 321, 323, 325, 327, 353, 355, 357, 359, 361, 365, 369, 371, 383, 387, 397 LANCIA 585, 587, 589, 591, 593, 595, 599, 601, 603	HR801 FIAT 335 FORD 423, 425, 435, 437, 439, 449, 455, 457, 465, 469, 475 LAND ROVER 613, 615 MAZDA 639	HR817 AUDI 67, 73 BMW 127, 129, 171 DACIA 287 NISSAN 783, 795, 799, 801, 811 RENAULT 1027, 1029, 1041, 1043, 1055, 1061, 1083, 1085, 1087 SEAT 1143, 1145, 1147, 1157, 1159, 1169, 1171, 1177 SKODA 1191 VW 1449, 1455, 1457, 1467, 1469, 1489, 1495, 1497, 1499, 1501, 1503, 1517, 1521, 1539	HR5050 JAGUAR 553, 557 HR5051 HONDA 479, 491 LAND ROVER 615 MG 729, 731 ROVER 1097, 1099, 1109, 1113, 1121 HR5052 LAND ROVER 611, 613, 617 LEYLAND / LDV 629 MG 733 ROVER 1121 HR5053 LAND ROVER 613, 617 HR5054 LAND ROVER 613, 617 HR5055 CHRYSLER 185 DAEWOO 293, 295 LANCIA 601 MERCEDES-BENZ 675, 677, 689, 691, 693, 695, 699, 703, 705, 707, 709 SSANGYONG 1205, 1207 VW 1493 HR5056 MERCEDES-BENZ 667, 671, 673, 683, 685, 719 HR5057 MERCEDES-BENZ 693, 699, 703 HR5060 RENAULT 1049, 1083 VOLVO 1407, 1409, 1411, 1413, 1427, 1429 HR5061 CHRYSLER 185, 187, 189 MINI 737	HR802 LAND ROVER 613 ROVER 1107, 1109, 1111, 1113, 1115 HR804 MERCEDES-BENZ 673, 675, 687 HR805 AUDI 93, 99 CITROËN 247, 261, 269, 271 FIAT 401 PEUGEOT 961, 967, 969, 973 VOLVO 1385, 1391, 1393, 1395, 1397, 1399, 1401, 1419, 1423, 1437 VW 1493, 1495 HR808 FORD 427, 429, 431, 433, 437, 439, 441, 457 MAZDA 635, 637 HR809 FORD 427, 429, 431, 433, 437, 439, 441, 457 MAZDA 635, 637	HR819 SSANGYONG 1205, 1207 HR822 AUDI 69, 73, 75, 77, 79, 83, 85, 91, 101 SEAT 1141, 1153, 1165, 1173, 1177 SKODA 1191, 1197 VW 1449, 1453, 1475, 1477, 1485, 1499, 1501, 1507, 1509, 1513, 1515, 1529, 1535 HR5030 FORD 443 VOLVO 1397, 1399, 1401, 1403, 1405, 1407, 1413, 1415, 1417, 1419, 1421, 1423, 1425, 1431, 1433, 1435, 1437, 1439 HR5031 LAND ROVER 615 MG 731 ROVER 1099, 1101, 1117	

							
HR5094	OPEL 883, 892, 893	JA777	FIAT 317, 377	JA5078	LAND ROVER 615	JB954	CITROËN 239
	RENAULT 1035, 1093	JA793	JAGUAR 553, 555		MG 731		JEEP 565, 569
	SAAB 1135	JA829	ALFA ROMEO 9, 11, 31, 33, 37, 39, 41, 43		ROVER 1099, 1101, 1117		PEUGEOT 965
	VAUXHALL 1371, 1377	JA840	ALFA ROMEO 9, 11, 31, 33, 37, 39, 41	JA5079	LAND ROVER 615		RENAULT 1033, 1035, 1041, 1051, 1071, 1075, 1077, 1079, 1089, 1091
HR5095	ALFA ROMEO 19, 23, 25, 27, 39	JA898	ALFA ROMEO 31, 33		MG 731		
	FIAT 325, 329, 385		NISSAN 791	JA5085	FORD 449, 471	JB975	TOYOTA 1291
	OPEL 841, 881, 889, 897	JA899	ALFA ROMEO 7, 9, 13, 31, 33	JB162	MERCEDES-BENZ 665, 681, 687, 697, 699, 715, 717, 719	JB983	TOYOTA 1265, 1279
	SAAB 1131, 1133		NISSAN 791	JB605	FIAT 325	JB997	RENAULT 1041, 1065, 1089
	VAUXHALL 1333, 1371, 1375, 1379	JA5000	LAND ROVER 613, 617	JB765	MG 733		VOLVO 1385
HR5096	OPEL 829, 849, 851	JA5001	LAND ROVER 613, 617	JB776	TRIUMPH 1313	JC023	MITSUBISHI 743, 755, 757, 761
	VAUXHALL 1321, 1353	JA5005	FIAT 319, 321, 353, 359, 367, 383	JB792	NISSAN 795, 801		PROTON 991
HR5097	MERCEDES-BENZ 667, 669, 719		LANCIA 603, 605	JB797	LAND ROVER 611, 613, 617	JC054	ALFA ROMEO 35, 37
HT025	RENAULT 1025, 1037, 1039, 1079, 1091	JA5006	FIAT 319, 321, 353, 359, 367, 383	JB802	ROVER 1121		CITROËN 249, 251, 257
			LANCIA 603, 605	JB811	TRIUMPH 1315		FIAT 319, 325, 331, 341, 343, 345, 347, 357
JA007	NISSAN 781	JA5007	FIAT 319, 355	JB812	FORD 415, 427, 451		IVECO 535, 537, 539, 541, 543, 545, 547, 549
JA008	NISSAN 781, 787		LANCIA 585, 589, 593	JB830	MAZDA 655		LANCIA 599
JA010	NISSAN 791	JA5008	FIAT 333, 361, 371, 387	JB833	FORD 413, 419		OPEL 829, 873
JA021	MAZDA 649, 651, 655	JA5010	FIAT 333, 359, 361, 365, 369, 381, 383, 387	JB836	FORD 413, 419		PEUGEOT 979
JA029	TOYOTA 1287		LANCIA 601, 605	JB837	CITROËN 213, 245, 253, 255, 261		RENAULT 1051, 1053, 1083, 1091
JA052	MAZDA 639, 651, 653, 657	JA5011	FIAT 333, 361, 371, 387	JB841	CITROËN 225, 227	JC055	ALFA ROMEO 35, 37
JA053	TOYOTA 1257, 1261	JA5014	MITSUBISHI 763, 765		PEUGEOT 929, 931, 949		CITROËN 249, 251, 257
JA077	TRIUMPH 1313	JA5035	ALFA ROMEO 15, 17, 23	JB842	TALBOT 1237, 1239, 1241, 1243		FIAT 319, 325, 331, 341, 343, 345, 347, 357
JA086	FORD 413		FIAT 321, 323, 335, 355, 359, 371, 385, 387	JB850	CITROËN 225, 227		IVECO 535, 537, 539, 541, 543, 545, 547, 549
	MAZDA 639		LANCIA 593, 595	JB855	PEUGEOT 929, 931, 949		LANCIA 599
JA272	JAGUAR 553, 555	JA5036	ALFA ROMEO 25, 31	JB851	TALBOT 1237, 1239, 1241, 1243		OPEL 829, 873
JA282	LEYLAND / LDV 627		FIAT 357	JB862	PEUGEOT 963, 965, 967, 983, 985		PEUGEOT 979
	MG 733	JA5037	VOLVO 1397, 1399, 1415, 1421, 1431, 1437	JB864	FORD 467		RENAULT 1051, 1053, 1083, 1091
	MORRIS 775		LANCIA 591, 595, 601	JB866	PEUGEOT 963, 965, 985		VAUXHALL 1321, 1363
JA323	LAND ROVER 611	JA5038	VOLVO 1397, 1399, 1403, 1405, 1407, 1415, 1417, 1419, 1421, 1431, 1433, 1435, 1437, 1439	JB869	RENAULT 1061	JC057	NISSAN 785, 815
JA415	OPEL 851, 861, 869		RENAULT 1049, 1083	JB875	RENAULT 1061, 1063, 1065, 1069, 1081	JC060	ISUZU 521, 525, 527
	VAUXHALL 1321, 1363	JA5039	VOLVO 1409, 1411, 1427, 1429	JB882	VOLVO 1385, 1387	JC088	DAIHATSU 303
JA439	AUSTIN 105, 107, 109	JA5040	RENAULT 1049, 1083	JB862	RENAULT 1041, 1069	JC091	PEUGEOT 965, 967
	MG 727, 733		VOLVO 1397, 1399, 1401, 1403, 1405, 1407, 1409, 1411, 1413, 1415, 1417, 1419, 1421, 1423, 1425, 1427, 1429, 1431, 1433, 1435, 1437, 1439, 1441	JB864	FORD 415, 427, 451		TALBOT 1243
	MORRIS 775	JA5042	VOLVO 1397, 1399, 1415, 1421, 1431, 1437	JB866	CITROËN 213, 245, 253, 255, 261	JC116	DAIHATSU 305
	ROVER 1117, 1119		VOLVO 1397, 1399, 1431	JB868	CITROËN 231, 233, 241		TOYOTA 1267, 1269, 1279, 1303, 1307
JA475	FORD 413, 419	JA5043	VOLVO 1397, 1399, 1431		PEUGEOT 985	JC122	MITSUBISHI 743, 755, 757, 761
	LOTUS 631	JA5044	VOLVO 1401, 1403, 1425, 1439	JB875	CITROËN 231, 233, 241		PROTON 991
JA499	OPEL 851, 861, 869	JA5058	TOYOTA 1249, 1283, 1291	JB889	FIAT 317	JC123	MITSUBISHI 743, 755, 757, 761
	VAUXHALL 1321, 1363	JA5068	FORD 443		PEUGEOT 985		PROTON 991
JA502	TRIUMPH 1313		VW 1463, 1487, 1517, 1539, 1547, 1553	JB894	PEUGEOT 939	JC124	MITSUBISHI 741, 745, 747
JA510	TRIUMPH 1313, 1315	JA5069	FORD 443		LAND ROVER 611, 613, 617	JC125	MITSUBISHI 763, 773
JA608	BEDFORD 113		VW 1463, 1487, 1517, 1539, 1547, 1553	JB894	LEYLAND / LDV 629	JC126	NISSAN 785, 789, 795, 801, 803, 821
JA609	BEDFORD 113	JA5075	LAND ROVER 611, 613		ROVER 1121		NISSAN 781, 789, 793, 795, 797, 801
JA613	FORD 413, 419	JA5076	LAND ROVER 611, 613	JB910	TRIUMPH 1315	JC128	NISSAN 785, 789, 795, 801, 803, 805, 819, 821, 823
JA625	TRIUMPH 1313				DAIHATSU 303	JC133	NISSAN 785, 789, 795, 801, 803, 805, 819, 821, 823
JA626	TRIUMPH 1313			JB917	TOYOTA 1265, 1267, 1269, 1287, 1293, 1303, 1305, 1307	JC134	FIAT 317, 363
JA689	JAGUAR 553, 555, 557			JB926	VOLVO 1385, 1387, 1389, 1393, 1395, 1397, 1399, 1401		NISSAN 797
JA752	FIAT 317, 363			JB949	TOYOTA 1257	JC135	CITROËN 221, 225, 227, 255, 263
JA757	FIAT 317, 329, 331, 373, 377, 389, 391, 393, 395			JB950	TOYOTA 1257		PEUGEOT 923, 925, 929, 931
	LANCIA 585, 587, 597						TALBOT 1241
JA768	FORD 413, 419, 427, 445, 457, 459, 463, 465, 467, 469, 471					JC137	FIAT 373, 377
JA769	FORD 413, 419, 427, 445, 457, 459, 463, 465, 467, 469, 471					JC140	SUBARU 1215
JA770	FORD 413, 419, 427, 445, 457, 459, 463, 465, 467, 469, 471						

NUMERICAL PARTS LIST









Numerische Teilenummernliste • Liste des références produits
Lista de referencias









							
JC146	VOLVO 1385, 1395, 1397, 1401 VW 1493, 1495	JC280	BEDFORD 111 OPEL 829, 831, 851, 853, 861, 863, 869 VAUXHALL 1323, 1337, 1345, 1363, 1365	JC423	CITROËN 223, 225, 227, 231, 241, 247, 251, 255, 265, 281 FIAT 379 LADA 579 PEUGEOT 933, 935, 941, 951, 953, 957, 977, 983 TALBOT 1239	JC551	MAZDA 639, 641, 653
JC152	AUDI 51, 53, 55, 57, 59, 61, 63, 65, 67, 71, 73, 77, 79, 83, 85, 87, 89, 93, 95, 97, 99 FORD 443 SEAT 1141, 1143, 1147, 1151, 1153, 1155, 1161, 1163, 1165, 1167, 1169, 1171, 1173, 1177, 1179, 1181 SKODA 1187, 1189, 1193, 1195 VOLVO 1385, 1395, 1397, 1399, 1401, 1419, 1423, 1437 VW 1451, 1453, 1457, 1459, 1461, 1463, 1467, 1469, 1471, 1473, 1475, 1477, 1479, 1481, 1483, 1485, 1487, 1489, 1491, 1493, 1495, 1497, 1501, 1503, 1505, 1507, 1509, 1511, 1513, 1515, 1525, 1527, 1529, 1531, 1533, 1535, 1537, 1541, 1543, 1545, 1549, 1551	JC281	BEDFORD 111 DAEWOO 293, 295 OPEL 829, 831, 833, 835, 837, 839, 847, 849, 851, 853, 855, 857, 861, 863, 865, 869, 885, 887 VAUXHALL 1323, 1325, 1327, 1329, 1335, 1337, 1339, 1345, 1347, 1351, 1353, 1354, 1355, 1363, 1365, 1373	JC429	BEDFORD 113 ISUZU 523, 525, 527 VAUXHALL 1361	JC554	MITSUBISHI 745, 759, 761
JC155	BEDFORD 113 OPEL 869, 871, 879 VAUXHALL 1343, 1345	JC282	DAEWOO 291 OPEL 831, 833, 845, 859, 863, 865, 867, 869, 873, 875, 879, 887, 889, 891 VAUXHALL 1329, 1331, 1333, 1335, 1339, 1341, 1343, 1345, 1347, 1349, 1357, 1367	JC435	AUSTIN 105, 109 LEYLAND / LDV 623, 627 MG 727, 735 ROVER 1113	JC555	TOYOTA 1267, 1303, 1305
JC163	MAZDA 639, 641, 653	JC283	OPEL 831, 863, 865, 867, 869, 879 VAUXHALL 1329, 1331, 1339, 1341, 1343, 1347, 1349	JC436	BEDFORD 111, 113 OPEL 831, 865, 887 VAUXHALL 1327, 1339, 1347	JC556	FORD 417, 433, 453 FORD 445, 459, 461 LEYLAND / LDV 623, 625 PEUGEOT 965, 985 SSANGYONG 1205
JC183	MAZDA 639, 641, 653	JC284	BEDFORD 113 ISUZU 523, 525, 527 VAUXHALL 1361	JC437	BEDFORD 111, 113 OPEL 831, 839, 841, 865, 887 VAUXHALL 1327, 1329, 1331, 1337, 1339, 1347	JC576	TOYOTA 1253, 1255, 1259, 1261, 1271, 1273, 1275, 1277, 1293, 1307, 1309
JC185	TOYOTA 1285, 1289	JC305	SAAB 1125	JC439	TOYOTA 1265, 1291	JC577	TOYOTA 1265, 1299
JC188	NISSAN 803	JC317	NISSAN 787, 791, 795, 807, 815	JC440	VOLVO 1385, 1387, 1389, 1393, 1395, 1397, 1399, 1401	JC578	TOYOTA 1257, 1261, 1269, 1271, 1277, 1293, 1295, 1303, 1305, 1309
JC214	NISSAN 821	JC336	ISUZU 523	JC441	MITSUBISHI 745, 749, 771, 773	JC579	TOYOTA 1257, 1261, 1269, 1271, 1277, 1293, 1295, 1303, 1305, 1309
JC215	TOYOTA 1265, 1279, 1287, 1289, 1299	JC344	TOYOTA 1291	JC443	MAZDA 653	JC580	NISSAN 801, 803, 805, 819, 821, 823
JC222	SUZUKI 1223, 1225, 1227	JC363	FORD 467	JC444	TOYOTA 1253, 1255, 1261, 1275, 1309	JC581	NISSAN 781, 783, 791, 793, 797, 801, 805, 813
JC224	HYUNDAI 507, 509 MITSUBISHI 745, 747, 751, 753, 755, 763, 767, 769	JC364	FORD 413, 461, 467	JC445	TOYOTA 1279, 1281, 1289	JC584	TOYOTA 1265, 1279, 1287, 1289, 1299
JC238	RENAULT 1033, 1035, 1041, 1075, 1077	JC371	TOYOTA 1263, 1279	JC459	NISSAN 799	JC595	SUBARU 1215, 1217
JC240	AUSTIN 109 ROVER 1105	JC386	RENAULT 1089	JC460	NISSAN 799	JC598	KIA 573, 577 MAZDA 647, 651, 653, 657
JC241	JAGUAR 553, 555, 557	JC399	TOYOTA 1259, 1271, 1273, 1275, 1277, 1293, 1307	JC471	NISSAN 781, 783, 791, 793, 797, 813	JC605	NISSAN 781, 787, 789, 791, 795, 807, 813, 815, 819
JC242	SUZUKI 1221, 1223	JC400	KIA 577 MAZDA 645, 647, 649, 651, 657	JC472	NISSAN 781, 783, 791, 793, 797, 801, 805, 813	JC611	MITSUBISHI 745, 751, 755, 763, 771, 773
JC243	AUDI 51, 57 VW 1471, 1487, 1491, 1501, 1505, 1541	JC401	KIA 577 MAZDA 645, 647, 649, 651	JC473	NISSAN 789, 793, 803, 805, 821	JC612	MITSUBISHI 745, 749, 751, 755, 767, 771, 773
JC250	MAZDA 639, 641, 653	JC402	TOYOTA 1253, 1255, 1261, 1265, 1277, 1279, 1281, 1309	JC475	NISSAN 781, 787, 789, 791, 795, 807, 813, 815	JC615	DAIHATSU 307, 309 TOYOTA 1249, 1281, 1283, 1285, 1287, 1295, 1305, 1307
JC251	MAZDA 649	JC404	HONDA 479, 497, 499	JC477	KIA 573, 577 MAZDA 647, 651, 653, 657	JC626	MITSUBISHI 747, 749
JC259	SEAT 1149, 1157, 1159, 1175 VW 1465, 1487, 1517, 1519, 1521, 1523, 1547	JC405	HONDA 479, 497, 499	JC478	AUDI 51, 53, 59, 95 SAAB 1125 SEAT 1151, 1153, 1161, 1163, 1169, 1177, 1179 VW 1457, 1459, 1463, 1467, 1469, 1471, 1473, 1475, 1477, 1487, 1489, 1491, 1501, 1503, 1505, 1507, 1509, 1525, 1533, 1535, 1541, 1549	JC627	MITSUBISHI 745, 747, 749, 759, 771
JC261	AUDI 57, 59, 61, 63, 65, 95, 97, 99 VW 1513, 1515, 1533	JC409	TOYOTA 1291	JC493	MITSUBISHI 745, 749, 753, 763, 771, 773	JC630	MAZDA 641
JC272	MITSUBISHI 741, 745, 747, 749, 767, 771, 773	JC410	TOYOTA 1265, 1279, 1299	JC497	ALFA ROMEO 9, 11, 31, 33, 37, 41	JC632	MITSUBISHI 749, 767, 771
JC276	TOYOTA 1265, 1279, 1281, 1303, 1305	JC414	TRIUMPH 1313	JC507	ALFA ROMEO 7, 31, 33 NISSAN 791	JC640	TOYOTA 1279, 1281, 1285, 1289
JC277	TOYOTA 1265, 1279, 1281, 1303	JC415	CITROËN 221, 223, 245, 247, 249, 255, 259, 261, 263, 269, 281, 283 FIAT 339, 397 PEUGEOT 933, 935, 939, 941, 951, 953, 955, 967, 971, 979, 981	JC521	HONDA 483, 485, 495, 499	JC641	SUZUKI 1223, 1225, 1227, 1229
		JC420	BEDFORD 115 SUZUKI 1223, 1225	JC532	HONDA 483, 493 SUZUKI 1225, 1227	JC642	MAZDA 639, 653
				JC534	HONDA 483, 485, 495, 499	JC643	BEDFORD 113 ISUZU 521, 523, 527, 529 OPEL 847 SSANGYONG 1205 VAUXHALL 1341
				JC545	TOYOTA 1263, 1265, 1277, 1279, 1281, 1303	JC652	HONDA 479, 497, 499
						JC653	NISSAN 815
						JC658	DAIHATSU 307, 309 TOYOTA 1281, 1283, 1285, 1287, 1295, 1307
						JC660	FIAT 363
						JC661	FIAT 329
						JC662	ALFA ROMEO 27 FIAT 329, 331, 391, 395, 397 LANCIA 585, 587, 589, 597
						JC664	MAZDA 643

												
JC665	KIA	575	JC756	DAEWOO	291	JC829	FORD	415, 417, 419, 429, 431, 451, 453	JC931	MAZDA	651, 655	
JC666	MAZDA	643		OPEL	833, 845, 859, 865, 867, 873, 875, 889, 891	JC838	TOYOTA	1249, 1289, 1299, 1307	JC938	DAIHATSU	303	
JC668	NISSAN	789, 803, 805, 821		VAUXHALL	1331, 1333, 1335, 1339, 1341, 1343, 1345, 1349, 1357, 1367	JC840	TOYOTA	1261, 1263	JC949	LAND ROVER	613	
JC669	RENAULT	1025, 1035, 1037, 1039, 1063, 1065, 1067, 1071, 1075, 1079				JC841	TOYOTA	1261, 1263, 1297		ROVER	1107, 1109, 1111, 1113, 1115	
JC670	BEDFORD	113	JC757	DAEWOO	291, 297	JC842	TOYOTA	1253, 1259, 1261, 1263, 1295, 1297	JC950	LAND ROVER	613	
	ISUZU	521, 531		OPEL	831, 867, 873, 887, 889	JC852	LAND ROVER	615		ROVER	1107, 1109, 1111, 1113, 1115	
	VAUXHALL	1361		VAUXHALL	1331, 1343, 1349		LOTUS	631	JC955	RENAULT	1025, 1027, 1037, 1039, 1071, 1081	
JC674	HONDA	483, 487, 489, 491, 493, 495, 499	JC759	CITROËN	217, 219, 223, 225, 231, 241, 243, 245, 247, 251, 253, 255, 261, 265, 267, 273, 275, 277, 281, 283		MG	727, 729, 731, 733	JC956	RENAULT	1025, 1027, 1037, 1039, 1055, 1071, 1081	
	ROVER	1105, 1109		FIAT	337, 339, 379	JC859	SUZUKI	1227, 1229	JC967	SUBARU	1213, 1215, 1217	
JC683	BEDFORD	113		LADA	579	JC861	SUZUKI	1227, 1229	JC968	MITSUBISHI	745, 747, 749, 759, 771	
	ISUZU	521, 529, 531		PEUGEOT	933, 941, 943, 945, 953, 955, 957, 959, 971, 977, 981, 983, 987, 989	JC863	HONDA	483, 487, 491, 493	JC969	MITSUBISHI	745, 747, 751, 765, 767	
	OPEL	847				JC867	SUZUKI	1223, 1229	JC973	FIAT	317, 327, 349, 363, 365, 381, 401	
	VAUXHALL	1341, 1361		SUZUKI	1231	JC868	SUZUKI	1223, 1229		SEAT	1157, 1175	
JC684	BEDFORD	113	JC760	NISSAN	781, 785, 797, 809, 819	JC869	NISSAN	811, 815, 817	JC974	KIA	575	
	ISUZU	521, 529		JC761	NISSAN	781, 783, 807, 809, 813, 817, 821	JC870	NISSAN	811, 815, 817		MAZDA	641
	OPEL	847		JC775	MAZDA	639, 651, 653, 657	JC872	LADA	579, 581	JC991	CITROËN	223, 243, 247, 253, 255, 267, 275, 277, 283
	VAUXHALL	1341		JC777	MAZDA	645, 649, 657	JC875	NISSAN	799		FIAT	379, 397
JC687	ACURA	3		JC778	MAZDA	649, 657	JC876	NISSAN	799		PEUGEOT	933, 945, 951, 955, 957, 977
	HONDA	495		JC779	MAZDA	649, 657	JC877	ROVER	1097, 1103, 1105, 1109, 1121		ROVER	1107, 1111
	ROVER	1117		JC781	MAZDA	643, 655, 657	JC879	TOYOTA	1257, 1271, 1295, 1303	JC995	NISSAN	813
JC688	HONDA	497		JC784	MAZDA	643	JC880	TOYOTA	1257, 1269, 1295	JC997	NISSAN	781, 785, 791, 793, 801, 803, 821
JC692	FIAT	373, 393		JC788	NISSAN	811, 815, 817, 819	JC881	TOYOTA	1257, 1269, 1295	JC999	NISSAN	781, 783, 813, 817, 821
JC693	FIAT	377		JC789	TOYOTA	1263	JC882	AUSTIN	107	JD001	NISSAN	781, 783, 807, 809, 813, 817, 821
JC694	LANCIA	587		JC790	FORD	415, 417, 429, 431, 451, 453, 463		CARBODIES	177	JD007	MITSUBISHI	741, 743, 759
JC696	FIAT	405		JC791	HONDA	495	JC883	HONDA	481, 499		PROTON	991
JC700	SUBARU	1215, 1217		JC793	ROVER	1117		ROVER	1113	JD009	FORD	415, 427, 429, 451
JC702	CITROËN	213, 215, 217, 219, 221, 227, 229, 231, 257, 259, 271, 273, 279, 281		JC794	PROTON	991	JC884	HONDA	481, 499	JD013	FIAT	329
	PEUGEOT	925, 927, 929, 931, 935, 937, 941, 947, 949, 953, 975, 985, 987		JC795	HYUNDAI	509		ROVER	1113	JD014	ALFA ROMEO	7, 13, 15
JC706	ALFA ROMEO	35, 37		JC796	NISSAN	743, 747, 749, 751, 759, 761	JC885	HONDA	481, 499	JD015	ALFA ROMEO	9, 19, 21, 27, 43
	FIAT	341, 343		JC797	HYUNDAI	509	JC886	LAND ROVER	613, 615	JD016	ALFA ROMEO	9, 27, 43
	IVECO	535, 545, 547		JC798	NISSAN	743, 747, 749, 751, 759, 761	JC900	FORD	447	JD017	ALFA ROMEO	9
JC707	ALFA ROMEO	35, 37		JC799	FIAT	447		NISSAN	781, 785, 793, 805, 807, 813, 819	JD018	ALFA ROMEO	9, 11, 43
	FIAT	341, 343		JC800	FORD	447	JC901	FORD	447	JD019	ALFA ROMEO	27
	IVECO	535, 545, 547		JC805	NISSAN	789, 805, 819, 821		NISSAN	781, 785, 793, 805, 807, 813, 819		FIAT	331, 391, 395, 397
JC712	PEUGEOT	965		JC806	FORD	447	JC907	ROVER	1097, 1103, 1105, 1109, 1121		LANCIA	587, 589
JC719	MITSUBISHI	743, 755, 757, 761		JC823	DAEWOO	293, 295	JC908	ROVER	1107, 1115	JD021	FIAT	405
	PROTON	991			OPEL	833, 837, 849, 855, 857, 863	JC909	LAND ROVER	613	JD022	FIAT	369, 405
JC723	FIAT	317			VAUXHALL	1323, 1327, 1351, 1354, 1355, 1365		ROVER	1107, 1109, 1111, 1113, 1115	JD023	MITSUBISHI	757, 761
JC724	FORD	417, 419, 431, 453		JC824	BEDFORD	111	JC928	ALFA ROMEO	7, 9, 11, 13, 29, 35, 39		PROTON	991, 993
JC732	IVECO	535			DAEWOO	291		CHRYSLER	185, 191	JD025	ALFA ROMEO	7, 9, 11, 13, 21, 35, 39
JC738	ALFA ROMEO	15, 17, 19			OPEL	831, 833, 835, 837, 839, 847, 849, 851, 855, 857, 863, 865, 885, 887		FORD	461		CHRYSLER	185, 191
	FIAT	321, 323, 337, 349, 351, 361, 371, 373, 375, 377, 387, 389, 391, 395, 397, 407			VAUXHALL	1323, 1325, 1327, 1329, 1335, 1337, 1339, 1347, 1351, 1353, 1354, 1355, 1363, 1365, 1373		JEOP	563, 567		FORD	461
	LANCIA	587, 589						LAND ROVER	615		JEOP	563, 567
JC739	TOYOTA	1265, 1281, 1305						LAND ROVER	615		LAND ROVER	615
JC740	TOYOTA	1265, 1281						OPEL	859		OPEL	859
JC745	NISSAN	791, 793, 795, 811, 815, 817						ROVER	1117, 1121		ROVER	1117, 1121
JC750	CITROËN	221, 223, 263, 281, 283						ROVER	1117, 1121		TOYOTA	1289
	PEUGEOT	933, 935, 939, 941, 951, 953, 955						TOYOTA	1289		VAUXHALL	1359
JC751	MITSUBISHI	745, 747, 751, 765, 767						VAUXHALL	1359	JD028	FORD	463
										JD029	NISSAN	781, 807, 813

NUMERICAL PARTS LIST









Numerische Teilenummernliste • Liste des références produits
Lista de referencias









											
JD051	HONDA	487	JD160	MERCEDES-BENZ	669, 671, 673, 677, 683, 685, 711, 713, 719, 721, 723	JD226	FIAT	325, 327, 357, 387	JD281	AUDI	55, 63, 85, 93, 97
JD052	ACURA	3					LANCIA	591, 595		SEAT	1151, 1153, 1157, 1163, 1165, 1167, 1177, 1183
	HONDA	483, 487, 489, 491, 493, 495		SSANGYONG	1205, 1207	JD227	FIAT	357		VW	1461, 1463, 1475, 1485, 1491, 1509, 1513, 1535
	ROVER	1105, 1111		VW	1493	JD228	ALFA ROMEO	25, 31	JD282	AUDI	55, 57, 63, 85, 87, 93, 97, 99
JD064	FORD	471, 473	JD161	MERCEDES-BENZ	669, 671, 673, 677, 679, 683, 685, 687, 701, 709, 711, 713, 719, 721, 723		FIAT	357		SEAT	1153, 1157, 1165, 1167, 1177, 1183
	LEYLAND / LDV	625		SSANGYONG	1205, 1207	JD229	IVECO	535		VW	1461, 1463, 1475, 1485, 1491, 1509, 1513, 1535
JD065	FORD	473	JD167	DAEWOO	293, 295	JD230	CITROËN	247, 261, 269, 271	JD283	BMW	123, 125, 127, 145
	LEYLAND / LDV	625		MERCEDES-BENZ	675, 677, 689, 693, 695, 699, 703, 705, 707		FIAT	401	JD291	MERCEDES-BENZ	665, 681, 683
JD066	FORD	473		SSANGYONG	1205, 1207	JD231	LANCIA	607	JD292	MERCEDES-BENZ	665, 681, 683, 685, 697, 715, 717, 719
	LEYLAND / LDV	625	JD169	DAEWOO	293, 295		PEUGEOT	961, 969, 973	JD293	MERCEDES-BENZ	665, 681, 683, 685
JD067	FIAT	325		MERCEDES-BENZ	675, 677, 689, 691, 693, 695, 699, 703, 705, 707	JD235	ALFA ROMEO	19, 21, 27	JD297	MERCEDES-BENZ	689, 697, 715, 717
JD071	BMW	123, 125, 145		SSANGYONG	1205, 1207	JD236	VW	1541, 1543	JD298	MERCEDES-BENZ	667, 687, 689, 697, 701, 713, 715, 717, 719
JD074	HONDA	487, 489, 493	JD170	AUDI	53, 69, 71, 77, 79, 83, 85, 93	JD237	VW	1543		SSANGYONG	1205, 1207
JD075	ACURA	3		FORD	443	JD239	BMW	131, 133, 137, 147, 149, 151, 171	JD299	MERCEDES-BENZ	667, 687, 689, 697, 701, 713, 715, 717, 719
	HONDA	483, 487, 489, 491, 493		HONDA	485	JD240	FORD	421, 423, 425, 435, 455, 457, 465		SSANGYONG	1205, 1207
	ROVER	1105, 1111		SEAT	1141, 1143, 1147, 1153, 1155, 1163, 1165, 1167, 1171, 1173, 1179, 1181		MAZDA	639	JD301	MERCEDES-BENZ	691, 693, 697, 699, 705
JD085	TOYOTA	1267, 1269, 1283, 1297, 1305, 1307		SKODA	1187, 1189, 1193, 1195, 1197	JD243	BMW	123, 125, 127, 145, 171	JD303	ISUZU	525, 527, 529
JD091	NISSAN	781, 783, 807, 809, 811, 813, 815, 817, 821		VW	1451, 1453, 1457, 1459, 1461, 1463, 1477, 1479, 1481, 1483, 1485, 1491, 1497, 1499, 1501, 1509, 1511, 1515, 1527, 1529, 1531, 1533, 1535, 1537, 1539, 1541, 1543, 1551	JD244	NISSAN	817		MAZDA	643
JD093	NISSAN	781, 807, 811, 815, 817				JD245	JEEP	563, 565		OPEL	841, 849, 855, 857, 863, 887
JD097	BEDFORD	115	JD171	AUDI	55, 57, 61, 63, 67, 87, 93, 99		RENAULT	1033, 1035, 1041, 1051, 1071, 1077, 1079, 1083, 1091		VAUXHALL	1325, 1331, 1339, 1349, 1353, 1355, 1357, 1365, 1367, 1375
	SUZUKI	1225, 1227		VW	1545	JD246	SEAT	1149, 1157, 1159, 1175	JD304	ISUZU	525, 527, 529
JD109	MAZDA	637	JD175	HONDA	499		VW	1465, 1487, 1517, 1519, 1521, 1523, 1547		MAZDA	643
JD110	NISSAN	781, 783, 807, 809, 813, 817, 821		TOYOTA	1257, 1261, 1267, 1269, 1271, 1303	JD264	FORD	417, 419, 421, 431, 433, 453		OPEL	841, 849, 855, 857, 863, 887
JD112	TOYOTA	1255, 1263, 1277, 1297	JD176	HONDA	499	JD265	FORD	417, 419, 421, 431, 433, 453		VAUXHALL	1325, 1331, 1339, 1349, 1353, 1355, 1357, 1365, 1367, 1375
JD131	MINISUBISHI	769, 771		TOYOTA	1251, 1257, 1261, 1267, 1269, 1271, 1303	JD266	FORD	447, 449	JD309	FORD	425, 437, 439, 449, 457, 469, 475
JD134	NISSAN	781, 809, 819	JD182	MERCEDES-BENZ	665, 683, 685, 697	JD271	ALFA ROMEO	13, 15, 17, 19, 21, 23, 25, 29, 39, 41, 43	JD310	FORD	421, 423, 425, 435, 437, 439, 449, 455, 457, 465, 469, 475
JD135	NISSAN	809	JD187	OPEL	859, 877		FIAT	319, 321, 323, 327, 355, 371, 385		MAZDA	639
JD144	JAGUAR	553, 555, 557		VAUXHALL	1345, 1359	JD272	ALFA ROMEO	15, 17, 21, 41, 43	JD311	LAND ROVER	615
JD146	CITROËN	241, 251	JD188	FORD	417, 419, 429, 431, 451, 453	JD273	ALFA ROMEO	13, 15, 17, 19, 21, 23, 25, 29, 39, 41, 43		LOTUS	631
	FIAT	351, 369, 373, 375, 377, 383, 387, 389, 391, 393, 403, 405	JD189	BMW	123, 125, 145		FIAT	319, 321, 323, 327, 355, 371, 385	JD312	AUDI	65, 89
	LANCIA	585, 589	JD194	TOYOTA	1251, 1253, 1255, 1259, 1263, 1295, 1297, 1299, 1301	JD274	LANCIA	585, 589, 593		VOLVO	1399, 1419, 1423, 1437
	PEUGEOT	979					LANCIA	585, 589, 593		VW	1493, 1543, 1545
	ZASTAVA	1555	JD198	FIAT	317, 325	JD275	BMW	129, 137, 139, 149, 155	JD315	BMW	157, 161, 165
JD148	FIAT	327, 363, 365, 367, 369, 381, 393, 403	JD221	ALFA ROMEO	7, 9, 13		JEEP	565	JD319	NISSAN	795
	LANCIA	601, 603	JD222	ALFA ROMEO	11, 21, 27, 29, 43, 45	JD276	LAND ROVER	615	JD327	AUDI	55, 57, 61, 63, 67, 87, 93, 99
JD150	FIAT	361, 369, 383		FIAT	331		OPEL	877		MG	727, 729, 731, 733
JD151	ALFA ROMEO	21	JD223	ALFA ROMEO	11, 13, 21, 29, 45		VAUXHALL	1369	JD331	MAZDA	643, 645, 647, 655, 657
	FIAT	327, 329, 395, 397, 401		LANCIA	601	JD277	BMW	139, 153, 155, 161	JD340	FIAT	319, 323, 333, 355, 357, 359, 361, 383
	LANCIA	587, 589, 591, 597, 599	JD224	ALFA ROMEO	11, 27, 29, 43		JEEP	565		LANCIA	585, 589, 593
JD152	ALFA ROMEO	21		FIAT	331	JD278	LAND ROVER	615	JD342	FIAT	319, 323, 353
	FIAT	327	JD225	FIAT	325, 327, 357, 387		OPEL	877		LANCIA	603
	LANCIA	591		LANCIA	591, 595		VAUXHALL	1369			
JD153	FIAT	327, 329, 395, 397, 401					VW	1541			
	LANCIA	587, 589, 591, 597, 599									
JD158	MERCEDES-BENZ	665, 671, 681, 683, 711, 713, 715, 721, 723									
	SSANGYONG	1205, 1207									
JD159	FIAT	383									
	MERCEDES-BENZ	665, 671, 681, 683, 711, 713, 715, 717, 719, 721, 723									
	SSANGYONG	1205, 1207									

							
JD343	FIAT 319, 323, 353 LANCIA 603	JD456	OPEL 845, 891 VAUXHALL 1341, 1351	JD520	CITROËN 217, 265, 267, 269, 275, 281, 283 FIAT 339 PEUGEOT 941, 945, 947, 953, 955, 957	JD597	SEAT 1145, 1147, 1149, 1151, 1157, 1159, 1161, 1163, 1169 SKODA 1189, 1191 VW 1455, 1457, 1465, 1469, 1495, 1497, 1517, 1519, 1521, 1523, 1527, 1547
JD345	VOLVO 1395, 1399, 1401	JD457	OPEL 847, 893 SAAB 1127	JD529	CITROËN 247, 261, 269, 271 FIAT 401 LANCIA 607 PEUGEOT 961, 969, 973	JD599	SEAT 1151, 1163, 1177 VW 1469, 1471, 1503, 1525, 1547
JD346	VOLVO 1395, 1399, 1401	JD458	OPEL 847, 893 VAUXHALL 1343, 1351	JD530	CITROËN 259, 273, 281 PEUGEOT 927, 937, 941	JD600	AUDI 67, 69, 73, 77, 79, 83 FORD 443 HONDA 485 SEAT 1141, 1143, 1151, 1155, 1161, 1163, 1167, 1171, 1173, 1177, 1179, 1181 SKODA 1187, 1191, 1193, 1195, 1197
JD348	SAAB 1125, 1127, 1129, 1131	JD459	OPEL 847, 877, 883, 893 SAAB 1127, 1131, 1135 VAUXHALL 1343, 1351, 1369, 1371, 1377	JD531	CITROËN 249, 257, 271 PEUGEOT 969, 979	JD601	SEAT 1145, 1147, 1149, 1151, 1157, 1159, 1161, 1163, 1169 SKODA 1189, 1191 VW 1455, 1457, 1465, 1469, 1495, 1519, 1521, 1523, 1527, 1547
JD409	mitsubishi 741 OPEL 829 RENAULT 1029, 1031, 1037, 1039, 1041, 1045, 1057, 1065, 1067, 1069, 1073, 1075, 1081, 1089 VAUXHALL 1321 VOLVO 1387, 1389, 1391, 1393	JD463	RENAULT 1057, 1073 VOLVO 1391, 1393, 1411, 1429	JD532	CITROËN 249, 257, 271 PEUGEOT 969, 979	JD602	AUDI 55, 57, 63, 65, 87, 97, 99
JD410	RENAULT 1029, 1031, 1059, 1073, 1087	JD464	FIAT 319, 321, 353, 367, 369 LANCIA 603	JD536	CITROËN 265, 267, 269, 277, 283, 285 FIAT 381, 397 LANCIA 605 PEUGEOT 945, 957, 959, 967, 973	JD603	AUDI 55, 63, 65, 87, 97, 99
JD411	RENAULT 1029, 1031, 1059, 1073, 1087	JD465	FIAT 319, 321, 353, 367, 369 LANCIA 603	JD538	CITROËN 215, 217, 229, 231, 259, 271, 281 PEUGEOT 927, 931, 935, 941, 947, 975, 977, 987	JD604	AUDI 69, 73, 75, 77, 83, 91, 101 SEAT 1141, 1153, 1165, 1173, 1177
JD413	RENAULT 1075, 1077	JD466	ALFA ROMEO 13, 15, 17, 25	JD539	FIAT 381, 397 PEUGEOT 943, 945, 967	JD605	AUDI 68, 69, 73, 75, 77, 83, 91, 101 SEAT 1141, 1153, 1165, 1173, 1177
JD414	RENAULT 1075, 1077	JD467	FIAT 321, 325, 355	JD542	FORD 443, 459, 467, 471	JD606	AUDI 53, 61, 73, 85, 93, 97 SEAT 1153, 1163 VW 1451, 1481, 1501
JD416	RENAULT 1081, 1083	JD468	ALFA ROMEO 15, 17, 23 FIAT 321, 323, 325, 333, 335, 355, 359, 361, 371, 385, 387 LANCIA 593, 595 OPEL 840, 841, 881, 889, 897 SAAB 1131 VAUXHALL 1333, 1371, 1375, 1379	JD543	FORD 443, 459, 467, 471	JD607	AUDI 67, 69 SEAT 1173, 1177 SKODA 1191
JD418	DACIA 287 RENAULT 1027, 1029, 1043, 1055, 1057	JD470	ISUZU 521, 523, 529 OPEL 859 VAUXHALL 1359	JD545	FORD 415, 427, 429, 445, 451 MAZDA 637	JD608	BMW 123, 125, 127, 145, 171
JD419	RENAULT 1029, 1033, 1045, 1047, 1059 VOLVO 1391, 1393	JD471	LAND ROVER 613, 615	JD551	CITROËN 213, 215, 219, 221, 227, 257, 259, 279, 281 PEUGEOT 925, 927, 929, 931, 941, 949, 953, 985, 987	JD611	BMW 129, 139, 153, 155, 161
JD420	RENAULT 1025, 1043, 1087, 1091	JD474	OPEL 839, 841 VAUXHALL 1329, 1331, 1337, 1339, 1347	JD554	FORD 417, 429, 451	JD612	BMW 129, 139, 153, 155, 161
JD421	RENAULT 1025, 1043, 1087, 1091	JD475	MERCEDES-BENZ 671, 673, 675, 683, 685, 687	JD561	BMW 127, 131, 137, 147, 149, 151	JD654	ROVER 1101, 1103, 1105, 1109, 1119
JD430	LADA 579 OPEL 843, 845, 867, 889, 891 VAUXHALL 1335, 1341, 1351	JD476	MERCEDES-BENZ 673, 675, 687	JD563	LOTUS 631 MG 727, 729, 733 ROVER 1097, 1107, 1111, 1117		
JD434	DACIA 287 RENAULT 1029, 1057	JD478	MERCEDES-BENZ 693	JD564	LOTUS 631 MG 727, 729, 733 ROVER 1097, 1107, 1111, 1117		
JD435	RENAULT 1035, 1049, 1083	JD482	AUDI 53, 55, 61, 85, 93, 97	JD565	ALFA ROMEO 7, 13, 15		
JD436	RENAULT 1049	JD483	AUDI 55, 61, 85, 93, 97 SEAT 1143, 1155, 1167, 1181 VW 1463, 1485, 1513, 1537, 1543, 1551	JD566	FIAT 319, 323, 333, 355, 359, 361, 383 LANCIA 585, 589, 593		
JD441	ROVER 1117	JD487	SEAT 1151, 1163 VW 1469, 1521, 1527, 1547	JD580	ALFA ROMEO 15, 17, 23 FIAT 321, 323, 335, 355, 359, 371, 385, 387 LANCIA 593, 595		
JD444	OPEL 835, 837, 849, 855, 857, 885, 887, 895 VAUXHALL 1323, 1325, 1327, 1329, 1355, 1373, 1379	JD488	SEAT 1151, 1163 VW 1517, 1521, 1527	JD581	ALFA ROMEO 25, 31 FIAT 357 LANCIA 591, 595		
JD445	OPEL 835, 855, 857, 885 VAUXHALL 1323, 1325, 1355, 1373	JD490	BMW 127	JD586	ALFA ROMEO 25, 31, 41, 45		
JD448	OPEL 857, 885 VAUXHALL 1355, 1373	JD492	BMW 131, 135, 141, 147, 149, 151, 157, 161, 173	JD587	ALFA ROMEO 25, 31, 41, 45		
JD450	DAEWOO 295, 297 OPEL 841, 843, 845, 859, 875, 883, 889, 891 VAUXHALL 1331, 1333, 1341, 1351, 1359, 1367, 1371, 1375, 1377	JD493	BMW 131, 137, 147, 149, 151				
JD451	CHEVROLET 179, 181 DAEWOO 293, 295, 297 OPEL 841, 843, 845, 859, 875, 883, 889, 891, 897 VAUXHALL 1331, 1333, 1335, 1341, 1351, 1357, 1359, 1367, 1371, 1375, 1377, 1379, 1381	JD497	BMW 131, 135, 137, 141, 147, 149, 151, 157, 161, 173				
JD455	LADA 579 OPEL 843, 845, 867, 889, 891 VAUXHALL 1335, 1341, 1351	JD498	FORD 415, 417, 419, 429, 431, 451, 453				
		JD519	CITROËN 245, 247, 255, 259, 265, 275, 281 FIAT 397 PEUGEOT 941, 953, 955, 957, 971, 979, 981				

NUMERICAL PARTS LIST









Numerische Teilenummernliste • Liste des références produits
Lista de referencias









								
JD655	ROVER	1101, 1103, 1105, 1109, 1119	JD5170	TOYOTA	1253, 1255, 1301	JD5210	SAAB	1131, 1133
JD656	ROVER	1101, 1103, 1105, 1109, 1119	JD5171	TOYOTA	1251, 1253, 1255, 1301	JD5219	FORD	429, 445
JD657	LAND ROVER	615	JD5183	BMW	121, 129, 131, 143, 149, 153, 157, 163, 167, 169, 171	JD5220	FORD	429, 445
	MG	729, 731		LAND ROVER	615, 617	JD5223	OPEL	851
	ROVER	1097, 1099, 1109, 1113, 1121		MG	731		VAUXHALL	1353
JD5107	BMW	129, 141, 143, 149, 153, 155, 157, 163, 169, 171		OPEL	877	JD5225	MERCEDES-BENZ	671, 673, 683, 685
	LAND ROVER	617		ROVER	1101	JD5226	MERCEDES-BENZ	669, 671, 673, 677, 679, 683, 687, 701, 709
	OPEL	877	JD5189	VAUXHALL	1369	JD5227	FORD	445
	VAUXHALL	1369		SAAB	1131	JD5228	AUDI	67
JD5108	BMW	129, 141, 143, 149, 153, 155, 157, 163, 169, 171		NISSAN	741, 769		SEAT	1145, 1147, 1149, 1151, 1159, 1161, 1169, 1171, 1177
	LAND ROVER	617		OPEL	873, 895		SKODA	1187, 1189, 1197
	OPEL	877		RENAULT	1031, 1033, 1043, 1045, 1047, 1051, 1057, 1059, 1085, 1089		VW	1449, 1455, 1467, 1469, 1497, 1499, 1521, 1523, 1525
	VAUXHALL	1369		VAUXHALL	1361, 1377	JD5229	OPEL	837, 887
JD5109	FORD	443	JD5190	VOLVO	1409, 1427		VAUXHALL	1329, 1373
	VW	1463, 1487, 1517, 1539, 1547, 1553		CITROËN	219, 237, 239, 243, 245, 247, 253, 257, 261, 267, 279	JD5230	FORD	429, 431, 457
JD5117	OPEL	829, 833, 849, 851		FIAT	381, 399, 401	JD5232	MAZDA	637
	VAUXHALL	1321, 1353		LANCIA	607	JD5232	FORD	443
JD5131	MAZDA	651, 655		PEUGEOT	937, 945, 949, 959, 961, 969, 973, 979, 983, 989		VW	1463, 1487, 1517, 1539, 1553
JD5132	MAZDA	651, 655		SUZUKI	1223	JD5233	SEAT	1149, 1159
JD5134	BMW	139, 153, 155, 161	JD5191	CITROËN	219, 237, 239, 243, 245, 247, 253, 257, 261, 267, 279		VW	1523
	OPEL	877		FIAT	381, 399, 401	JD5235	SEAT	1151, 1153, 1161, 1163, 1169, 1177, 1179
	VAUXHALL	1369		LANCIA	607		VW	1473, 1475, 1477, 1507, 1509, 1529, 1549
JD5135	MERCEDES-BENZ	667, 719		PEUGEOT	937, 945, 949, 959, 961, 969, 973, 979, 983, 989	JD5243	TOYOTA	1251, 1261, 1267, 1269, 1271, 1273, 1295, 1301
JD5136	MERCEDES-BENZ	667, 719		SUZUKI	1223	JD5255	OPEL	843, 845, 859, 875, 881, 883, 889, 891, 893, 897
JD5143	FIAT	319, 323, 333, 355, 357, 359, 361, 383	JD5192	CITROËN	219, 229, 243, 251, 275		SAAB	1133
	LANCIA	585, 589, 593		FIAT	379		VAUXHALL	1333, 1337, 1357, 1367, 1371, 1375, 1377, 1381
JD5144	ALFA ROMEO	7, 9, 11, 13, 21, 29, 35, 39		PEUGEOT	937, 943, 981, 989	JD5256	OPEL	843, 845, 859, 875, 881, 883, 889, 891, 893, 897
	CHRYSLER	185, 191		TOYOTA	1275		SAAB	1133
	JEEP	563, 565	JD5196	OPEL	841, 857, 871, 881, 885, 887, 889, 895		VAUXHALL	1333, 1337, 1357, 1367, 1371, 1375, 1377, 1381
	ROVER	1117		SAAB	1131	JD5268	FORD	459, 463, 467, 473
JD5146	BMW	157, 159, 163, 165, 167, 171		VAUXHALL	1331, 1357, 1361, 1373, 1375, 1379	JD5269	OPEL	835, 837, 855, 885, 887
JD5147	OPEL	835, 837, 839, 849, 853, 871, 885, 887, 895	JD5197	OPEL	841, 857, 871, 881, 885, 887, 889, 895		VAUXHALL	1323, 1325, 1329, 1355, 1373
	VAUXHALL	1323, 1327, 1355, 1359, 1373, 1379		SAAB	1131	JD5277	OPEL	843, 845, 859, 881, 883, 891, 893, 897
JD5148	OPEL	835, 837, 839, 853, 871, 885, 887, 895		VAUXHALL	1331, 1357, 1361, 1373, 1375, 1379		SAAB	1133
	VAUXHALL	1323, 1327, 1355, 1359, 1373, 1379	JD5201	OPEL	847, 893		VAUXHALL	1333, 1337, 1357, 1371, 1375
JD5149	OPEL	835, 853		VAUXHALL	1343, 1351	JD5278	AUDI	67
	VAUXHALL	1323, 1355, 1379	JD5202	OPEL	847, 877, 883, 893		SEAT	1145, 1149, 1159
JD5151	FORD	415, 427, 429, 445		SAAB	1131, 1135		SKODA	1187, 1197
	MAZDA	637		VAUXHALL	1343, 1369, 1371, 1377		VW	1465, 1497, 1523
JD5155	FIAT	317, 347, 349, 365, 367, 403, 405	JD5203	OPEL	847, 877, 883, 893	JD5279	AUDI	67
	LANCIA	603		SAAB	1131, 1135		SEAT	1145, 1149, 1159
JD5159	TOYOTA	1269, 1311		VAUXHALL	1343, 1369, 1371, 1377		SKODA	1187, 1197
JD5160	TOYOTA	1251, 1261, 1267, 1269, 1271, 1273, 1295, 1301	JD5204	OPEL	877, 893		VW	1465, 1497, 1523
				SAAB	1135	JD5280	SAAB	1125, 1127, 1129, 1131, 1133
JD5164	FORD	429, 431, 433, 437, 439, 441, 457		VAUXHALL	1369, 1377			
	MAZDA	635, 637	JD5205	SMART	1201			
			JD5206	SMART	1201			
JD5281	SAAB	1131, 1133				JD5289	VOLVO	1407, 1409, 1411, 1413, 1427, 1429
JD5282	SAAB	1131, 1133				JD5290	FORD	431, 433, 437, 439, 457
JD5288	SEAT	1175					MAZDA	635
	VOLVO	1405, 1407, 1413, 1415, 1419, 1421, 1423, 1433, 1435, 1437, 1439, 1441				JD5291	SEAT	1155
JD5289	VOLVO	1407, 1409, 1411, 1413, 1427, 1429					SKODA	1189, 1195
JD5290	FORD	431, 433, 437, 439, 457					VW	1453, 1483, 1501
	MAZDA	635				JD5292	SEAT	1143
JD5291	SEAT	1155					VW	1499, 1537, 1543
	SKODA	1189, 1195				JD5293	AUDI	67
	VW	1453, 1483, 1501					SEAT	1143, 1151, 1155, 1161, 1171, 1177
JD5292	SEAT	1143					SKODA	1189, 1191, 1195
	VW	1499, 1537, 1543					VW	1449, 1453, 1457, 1461, 1467, 1469, 1483, 1485, 1489, 1499, 1501, 1503, 1525, 1537, 1539, 1543
JD5293	AUDI	67				JD5297	VOLVO	1425, 1441
	SEAT	1143, 1151, 1155, 1161, 1171, 1177				JD5298	AUDI	67
	SKODA	1189, 1191, 1195					SEAT	1145, 1147, 1159, 1169, 1171, 1175, 1177
	VW	1449, 1453, 1457, 1461, 1467, 1469, 1483, 1485, 1489, 1499, 1501, 1503, 1525, 1537, 1539, 1543					SKODA	1187, 1189, 1197
JD5297	VOLVO	1425, 1441				JD5299	FORD	437, 439, 441, 447, 449
JD5298	AUDI	67					VOLVO	1409, 1429
	SEAT	1145, 1147, 1159, 1169, 1171, 1175, 1177				JD5300	OPEL	859, 875
	SKODA	1187, 1189, 1197					VAUXHALL	1367
	VW	1449, 1455, 1467, 1469, 1497, 1499, 1521, 1525				JD5311	FORD	413, 417, 421, 433, 439, 441, 447, 449
JD5299	FORD	437, 439, 441, 447, 449				JD5312	FORD	413, 439, 441, 445, 447, 449, 469, 475
	VOLVO	1409, 1429				JD5313	FORD	439, 441, 445, 469, 475
JD5300	OPEL	859, 875				JD5318	SEAT	1145, 1147, 1157, 1159, 1169
	VAUXHALL	1367					VW	1455, 1495, 1497, 1517, 1521
JD5311	FORD	413, 417, 421, 433, 439, 441, 447, 449				JD5327	KIA	575
JD5312	FORD	413, 439, 441, 445, 447, 449, 469, 475				JD5328	KIA	575
JD5313	FORD	439, 441, 445, 469, 475				JD5329	OPEL	839, 849, 857, 871
JD5318	SEAT	1145, 1147, 1157, 1159, 1169					VAUXHALL	1329, 1353, 1357
	VW	1455, 1495, 1497, 1517, 1521				JD5330	OPEL	839
JD5327	KIA	575					VAUXHALL	1329, 1337
JD5328	KIA	575				JD5331	OPEL	839, 857, 871
JD5329	OPEL	839, 849, 857, 871					VAUXHALL	1329, 1357, 1361
	VAUXHALL	1329, 1353, 1357				JD5332	OPEL	839, 849, 857, 871
JD5330	OPEL	839					VAUXHALL	1329, 1353, 1357
	VAUXHALL	1329, 1337				JD5333	OPEL	839, 849, 857, 871
JD5331	OPEL	839, 857, 871					VAUXHALL	1329, 1353, 1357
	VAUXHALL	1329, 1357, 1361				JD5334	OPEL	839, 857, 871
JD5332	OPEL	839, 849, 857, 871					VAUXHALL	1329, 1337, 1357, 1361
	VAUXHALL	1329, 1353, 1357				JD5336	OPEL	839, 849, 857, 871
JD5333	OPEL	839, 849, 857, 871					VAUXHALL	1329, 1353, 1357
	VAUXHALL	1329, 1353, 1357				JD5337	FIAT	341
JD5334	OPEL	839, 857, 871					IVECO	543
	VAUXHALL	1329, 1337, 1357, 1361						
JD5336	OPEL	839, 849, 857, 871						
	VAUXHALL	1329, 1353, 1357						
JD5337	FIAT	341						
	IVECO	543						

											
JD5338	FIAT	341	JD5411	FIAT	333, 353, 367, 369	JD5769	SUZUKI	1221, 1223, 1225, 1229, 1231, 1233	JD5813	AUDI	71, 79, 85
JD5340	AUDI	67		LANCIA	595, 605					SEAT	1143, 1175, 1181
	SEAT	1143, 1151, 1161, 1171, 1177		OPEL	829, 847, 853, 883	JD5770	SUZUKI	1221, 1223, 1225, 1229, 1231, 1233		SKODA	1195
	SKODA	1191, 1195		SUZUKI	1225, 1229, 1233					VW	1463, 1485, 1491, 1501, 1513, 1515, 1539
	VW	1449, 1453, 1457, 1467, 1469, 1483, 1485, 1489, 1499, 1503, 1525, 1539	JD5412	VAUXHALL	1353, 1373	JD5771	TOYOTA	1257	JD5814	AUDI	69
JD5341	AUDI	73		FIAT	333, 353, 367, 369	JD5774	DAEWOO	291, 293, 295, 297		SEAT	1151, 1161
	FIAT	383		LANCIA	595, 605	JD5775	HONDA	489		SKODA	1187, 1191, 1197
	SKODA	1197		OPEL	829, 847, 853, 883	JD5776	HYUNDAI	503		VW	1463, 1467, 1489, 1505, 1523, 1525, 1539
	VW	1501, 1503, 1513	JD5413	SUZUKI	1225, 1229, 1233	JD5777	HYUNDAI	503, 505, 509	JD5815	AUDI	73, 79, 85
JD5347	OPEL	843, 859, 875, 883, 889, 891, 893, 897		VAUXHALL	1353, 1373	JD5778	HYUNDAI	503, 505, 509		SEAT	1143, 1175, 1181
	SAAB	1133		FIAT	333, 353, 367, 369	JD5779	JEEP	563, 569		SKODA	1195
	VAUXHALL	1333, 1337, 1357, 1367, 1371, 1375, 1377, 1381	JD5428	LANCIA	595, 605	JD5780	JEEP	565, 567, 569		VW	1483, 1493, 1515, 1541
JD5373	SEAT	1171, 1177		OPEL	829, 833, 847, 853, 883	JD5781	PROTON	741, 743, 745, 749, 757, 759, 769	JD5816	SEAT	1147, 1157
	VW	1449, 1469, 1497, 1525		VAUXHALL	1353, 1373	JD5782	RENAULT	1049		SKODA	1187, 1195
JD5375	FIAT	327, 333, 359, 361, 363, 365, 367, 369, 381, 383, 387, 393, 403	JD5737	BMW	121, 123, 125, 129, 133, 167, 173	JD5783	SUBARU	1211, 1213, 1215, 1217	JD5817	SKODA	1187, 1189
	LANCIA	601, 603, 605		OPEL	859	JD5785	SUZUKI	1229, 1233		VW	1495
JD5376	ALFA ROMEO	19, 23, 39		VAUXHALL	1357	JD5786	TOYOTA	1263, 1297	JD5818	SKODA	1187, 1189
	FIAT	385	JD5738	TOYOTA	1269, 1301, 1311	JD5794	CHEVROLET	179, 181		VW	1495
	OPEL	841, 881, 889, 897	JD5739	CHEVROLET	179, 181	JD5797	JEEP	567	JD5819	SKODA	1187
	SAAB	1131, 1133		DAEWOO	291, 293, 295, 297	JD5798	MERCEDES-BENZ	713		VW	1463, 1519
	VAUXHALL	1333, 1371, 1375, 1379	JD5740	CHEVROLET	179, 181	JD5799	JEEP	567	JD5820	AUDI	79, 85
JD5377	MERCEDES-BENZ	673, 685		DAEWOO	295, 299	JD5800	MERCEDES-BENZ 675, 679, 689, 697, 701, 713	667, 669		VW	1513
JD5378	JEEP	567	JD5741	DAIHATSU	309	JD5801	MERCEDES-BENZ	667, 669	JD5821	SMART	1201
	MERCEDES-BENZ 671, 673, 675, 679, 683, 685, 689, 697, 701		JD5742	DAIHATSU	309	JD5802	MERCEDES-BENZ	669, 677, 681, 709	JD5822	SMART	1201
JD5379	MERCEDES-BENZ	711, 719, 721	JD5743	DAIHATSU	309	JD5803	MERCEDES-BENZ	666, 667, 669	JD5826	CHRYSLER	185, 187
JD5380	MERCEDES-BENZ 671, 673, 679, 683, 685, 699, 711, 719, 721		JD5744	DAIHATSU	303, 307, 309	JD5804	MERCEDES-BENZ	667, 669		MINI	737
JD5385	MERCEDES-BENZ 673, 675, 679, 687, 689, 695, 699, 701, 703, 705, 707, 709, 721, 723		JD5745	DAIHATSU	303, 307, 309	JD5805	AUDI	73	JD5827	CHRYSLER	185, 187
JD5386	LANCIA	601	JD5746	FORD	417, 419, 431, 451, 453	JD5806	SEAT	1143, 1175, 1181		MINI	737
	MERCEDES-BENZ 673, 675, 679, 687, 689, 695, 699, 701, 703, 705, 707, 709, 721, 723		JD5747	FORD	451	JD5807	SKODA	1195	JD5828	CITROËN	215, 229, 231, 259, 271
JD5393	DACIA	287	JD5748	HONDA	479, 485, 487, 489	JD5808	VW	1483, 1485, 1493, 1515, 1541		PEUGEOT	925, 927, 935, 941, 947, 977, 987
	RENAULT	1027, 1029, 1041, 1045, 1053, 1055, 1057, 1061, 1083, 1085, 1087	JD5749	HONDA	481, 499	JD5809	SKODA	1187	JD5829	CITROËN	217, 225, 229, 233, 235, 271, 273
JD5394	RENAULT	1027, 1053, 1061, 1083, 1087	JD5750	HONDA	479, 481	JD5810	VW	1449, 1463, 1467, 1469, 1489, 1497, 1505, 1523, 1539		FORD	431, 433, 439, 441
JD5398	OPEL	835, 849, 869	JD5751	HYUNDAI	503, 507, 509, 511	JD5811	SEAT	1147, 1157		MAZDA	635
	VAUXHALL	1325, 1337, 1351, 1359	JD5753	KIA	575	JD5812	SKODA	1199		MINI	737
JD5399	OPEL	835, 849, 869	JD5754	MAZDA	643, 645, 647, 655, 657	JD5813	VW	1463, 1519	JD5830	CITROËN	217, 233, 235, 273
	VAUXHALL	1325, 1337, 1351, 1359	JD5755	MAZDA	645, 649, 657, 659	JD5814	SEAT	1147, 1157		FORD	433, 439, 441
JD5400	OPEL	835, 869, 895	JD5756	MAZDA	645, 649, 657, 659	JD5815	SKODA	1199		MAZDA	635
	VAUXHALL	1325, 1359, 1379	JD5757	DAEWOO	291, 293, 295, 297	JD5816	VW	1483, 1485, 1493, 1515, 1541		MINI	737
JD5401	OPEL	835, 869, 895	JD5758	MITSUBISHI	743, 755, 757	JD5817	SEAT	1143, 1175, 1181		PEUGEOT	929, 935, 937, 939, 947, 961, 975, 977
	VAUXHALL	1325, 1359, 1379	JD5759	PROTON	991, 993	JD5818	SKODA	1187		RENAULT	1093
JD5402	DACIA	287	JD5758	MITSUBISHI	741, 743, 745, 749, 757, 759	JD5819	VW	1463, 1519	JD5831	CITROËN	217, 229, 231, 233, 273
	NISSAN	783, 795, 799, 801, 811	JD5760	CHRYSLER	189	JD5820	SEAT	1147, 1157		PEUGEOT	935, 937, 939, 947, 975, 987
	RENAULT	1027, 1029, 1041, 1043, 1055, 1061, 1083, 1085, 1087	JD5761	MITSUBISHI	765	JD5821	SKODA	1187, 1195	JD5832	CITROËN	265, 275, 283
			JD5762	NISSAN	813, 823	JD5822	VW	1515		PEUGEOT	943, 957
			JD5763	CITROËN	225	JD5823	SEAT	1147, 1157	JD5833	CITROËN	235, 237, 239, 243, 245, 253, 261, 275, 277
			JD5764	PEUGEOT	953, 955	JD5824	SKODA	1187, 1195		FIAT	381, 397, 399
			JD5765	CITROËN	225	JD5825	VW	1463, 1519		LANCIA	597, 605
			JD5766	PEUGEOT	953, 955	JD5826	SKODA	1187, 1189		PEUGEOT	937, 947, 957, 959, 961, 963, 969, 973, 981
			JD5767	OPEL	859, 877, 879, 881	JD5827	SEAT	1147, 1157			
			JD5768	VAUXHALL	1345, 1359	JD5828	SKODA	1187, 1189			
				SKODA	1189						
				SUBARU	1211, 1213, 1215						
				SUBARU	1211, 1213, 1215, 1217						

NUMERICAL PARTS LIST









Numerische Teilenummernliste • Liste des références produits
Lista de referencias









											
JD5834	MERCEDES-BENZ	667, 719	JD5873	AUDI	71, 79	JD5897	OPEL	883, 893	JE015	DAIHATSU	303, 305
JD5835	MERCEDES-BENZ	669, 677, 681, 709		SEAT	1143, 1175, 1181		RENAULT	1035, 1093		TOYOTA	1257, 1259, 1261, 1263, 1265, 1267, 1269, 1271, 1275, 1277, 1279, 1281, 1283, 1285, 1287, 1289, 1291, 1293, 1295, 1297, 1303, 1305, 1307
	PEUGEOT	947		SKODA	1195		SAAB	1135			
JD5836	DAIHATSU	307, 309, 311		VW	1463, 1485, 1491, 1513, 1515, 1539	JD5898	VOLVO	1425	JE017	TOYOTA	1281, 1283, 1285, 1287, 1289, 1309
	TOYOTA	1311	JD5874	AUDI	73, 101	JD5899	HYUNDAI	503			
JD5837	DAIHATSU	307, 309, 311		VW	1463, 1487, 1499, 1517, 1539, 1547	JD5900	HYUNDAI	503, 507			
	TOYOTA	1311	JD5875	CHRYSLER	191	JD5901	TOYOTA	1251, 1275, 1277, 1299, 1301, 1307	JE019	BEDFORD	113
JD5838	HONDA	495	JD5876	JEEP	569	JD5902	MERCEDES-BENZ	675, 679, 681, 691, 701, 703		ISUZU	521, 523, 529
JD5839	HONDA	495	JD5877	JEEP	569	JD5903	OPEL	843, 883, 897		OPEL	847
JD5840	HONDA	495	JD5878	CITROËN	269, 271		VAUXHALL	1333, 1335, 1379, 1381		SSANGYONG	1205
JD5841	NISSAN	793, 799, 801		PEUGEOT	961, 969	JD5904	OPEL	829, 833, 849, 851, 853, 855, 869, 883		TOYOTA	1265, 1277, 1279, 1281
JD5845	CITROËN	225	JD5879	CITROËN	269, 271		VAUXHALL	1321, 1323, 1351, 1353, 1355, 1357, 1359, 1373	JE023	TOYOTA	1291
	DAIHATSU	305, 309		PEUGEOT	961, 969	JD5905	DAIHATSU	743, 759	JE037	TOYOTA	1257, 1261, 1263, 1279
	PEUGEOT	929	JD5880	CITROËN	269, 271	JD5906	CITROËN	237, 239	JE048	TOYOTA	1283, 1309
	TOYOTA	1253, 1297, 1309, 1311		PEUGEOT	961, 969		FIAT	401	JE050	DAIHATSU	303
JD5846	CITROËN	225	JD5881	CITROËN	235, 237, 239, 253	JD5906	FIAT	401		TOYOTA	1267, 1287, 1293, 1303, 1307
	DAIHATSU	305, 309		FIAT	379, 397		PEUGEOT	961, 963, 971, 975	JE052	MITSUBISHI	749, 753
	PEUGEOT	929		FORD	439, 443, 469	JD5907	RENAULT	1025, 1031, 1051, 1089		TOYOTA	1251, 1253, 1259, 1263, 1265, 1277, 1279, 1281, 1295, 1297, 1299, 1301, 1303, 1307
	TOYOTA	1253, 1297, 1309, 1311		LANCIA	597		CITROËN	237, 239	JE094		
JD5849	SKODA	1187, 1189		PEUGEOT	949, 963, 971, 975, 983		FIAT	401			
	VW	1495	JD5882	CITROËN	229, 231, 233	JD5907	PEUGEOT	961, 963, 971, 975	JE101	KIA	575
JD5851	AUDI	81, 87, 89, 90, 91		PEUGEOT	935, 937, 947, 975		RENAULT	1025, 1031, 1051, 1089		MAZDA	637, 639, 641, 653, 655
	SKODA	1199	JD5883	CITROËN	239	JD5908	RENAULT	1031, 1033, 1043, 1045, 1047, 1049, 1057, 1059, 1085, 1087, 1089	JE102	KIA	573, 575, 577
	VW	1515		PEUGEOT	961, 963, 971, 975	JD5909	BMW	121, 123, 129, 135, 139, 143, 145, 153, 161, 163, 169, 173, 175		MAZDA	639, 643, 649, 653, 657
JD5857	SEAT	1143, 1175, 1183	JD5884	RENAULT	1027, 1059, 1091	JD5910	RENAULT	1025, 1031, 1033, 1043, 1045, 1047, 1049, 1057, 1059, 1085, 1087, 1093	JE106	TOYOTA	1253, 1257, 1259, 1261, 1265, 1269, 1271, 1275, 1277, 1279, 1293, 1295, 1303, 1305, 1307, 1309
	VW	1485, 1539	JD5885	RENAULT	1031		BMW	121, 123, 129, 135, 139, 143, 145, 153, 161, 163, 169, 173, 175	JE117	VW	1475, 1535
JD5858	BMW	123, 125, 127, 171	JD5886	RENAULT	1031	JD5911	RENAULT	1025, 1033, 1043, 1049, 1059, 1085, 1087, 1093	JE119	BEDFORD	111, 113
JD5863	CITROËN	225	JD5887	RENAULT	1031	JD5912	RENAULT	1049		OPEL	829, 831, 839, 853, 861, 863, 865, 869, 887
	DAIHATSU	305, 309	JD5888	RENAULT	1031	JD5914	MAZDA	643		VAUXHALL	1323, 1327, 1329, 1337, 1339, 1345, 1347, 1363, 1365
	PEUGEOT	929	JD5889	RENAULT	1049, 1059		OPEL	841, 849, 857, 863, 887	JE120	BEDFORD	111
	TOYOTA	1253, 1297, 1309, 1311	JD5890	RENAULT	1043, 1047, 1057, 1085	JD5915	VAUXHALL	1325, 1355		DAEWOO	291, 295, 297
JD5864	BMW	121, 135, 139, 143, 145, 153, 161, 163, 169, 171, 173, 175	JD5891	NISSAN	787, 795, 811, 823	JD5916	BMW	131, 133, 135, 137, 141, 143, 147, 149, 151, 157, 161, 163, 169, 171, 173, 175		OPEL	831, 833, 841, 845, 857, 859, 863, 865, 867, 869, 873, 875, 879, 885, 887, 889, 891
JD5865	FORD	433, 437, 439, 441		OPEL	873		VAUXHALL	1325, 1355		VAUXHALL	1325, 1327, 1329, 1331, 1333, 1335, 1339, 1341, 1343, 1345, 1347, 1349, 1351, 1357, 1365, 1367, 1375, 1377
	MAZDA	635, 653	JD5892	RENAULT	1025, 1035, 1049, 1051, 1093	JE011	MITSUBISHI	745	JE124	DAIHATSU	307, 309
	VOLVO	1403, 1407, 1429		VAUXHALL	1361	JE012	DAIHATSU	305, 307, 309		TOYOTA	1281, 1283, 1285, 1287, 1293, 1295, 1303, 1307
JD5866	FORD	427, 429, 433, 437, 441		NISSAN	787, 795, 811, 823		TOYOTA	1249, 1255, 1257, 1261, 1263, 1265, 1269, 1277, 1279, 1281, 1283, 1285, 1287, 1289, 1293, 1295, 1299, 1303, 1305, 1307, 1309	JE126	PEUGEOT	965
	MAZDA	635, 651, 653	JD5893	RENAULT	1027, 1053, 1061, 1083, 1087				JE138	AUDI	53, 59, 65, 95
	VOLVO	1403, 1407, 1429	JD5894	RENAULT	1029, 1041, 1055, 1057, 1061, 1085					VW	1493, 1495
JD5867	OPEL	861	JD5895	RENAULT	1043, 1059, 1085, 1089	JE013	DAIHATSU	303, 305	JE145	PEUGEOT	939
JD5868	ALFA ROMEO	27, 37, 45	JD5896	OPEL	883, 893		TOYOTA	1249, 1265, 1267, 1269, 1279, 1287, 1293, 1299, 1303, 1305, 1307	JE146	DAIHATSU	303, 309, 311
	CHEVROLET	179, 181		RENAULT	1035, 1093	JE014	NISSAN	781, 787	JE154	VW	1465, 1469, 1487, 1547
	FIAT	331		SAAB	1135						
	OPEL	845, 881, 883, 891, 893, 897		VAUXHALL	1371, 1377						
	VAUXHALL	1335, 1371, 1377, 1379, 1381									
JD5869	CHEVROLET	181									
	OPEL	881, 893									
	VAUXHALL	1371, 1377, 1381									
JD5870	CHEVROLET	181									
	OPEL	881, 893, 897									
	VAUXHALL	1371, 1377, 1381									
JD5871	MITSUBISHI	743									
JD5872	AUDI	81, 89, 91, 99									
	VW	1517, 1539									

							
JE160	AUDI 57 VW 1457, 1459, 1467, 1471, 1475, 1477, 1489, 1491, 1501, 1507, 1509, 1525, 1533, 1535, 1541, 1543, 1545	JE719	FORD 413, 415, 417, 419, 427, 429, 431, 445, 451, 453, 459, 463, 465, 467, 471 MITSUBISHI 757	JE5070	CITROËN 237, 239 FIAT 401 PEUGEOT 961, 963, 971, 975 RENAULT 1025, 1031, 1051, 1089	JF123	ALFA ROMEO 9, 11, 13, 35, 39 CITROËN 249, 251, 257 FIAT 343, 345, 347 FORD 461 IVECO 537, 539, 541, 543, 545, 547, 549 JEEP 563, 567 LAND ROVER 615 OPEL 859 PEUGEOT 979 RENAULT 1053 ROVER 1117, 1121 TOYOTA 1289 VAUXHALL 1359
JE185	MAZDA 649, 657	JE729	FIAT 349	JE5071	CITROËN 237, 239 FIAT 401 PEUGEOT 961, 963, 971, 975 RENAULT 1025, 1031, 1051, 1089	JF145	FIAT 361, 363, 365, 367, 369, 381, 393, 403 LANCIA 601, 603
JE187	LANCIA 589	JE735	BEDFORD 115	JE5072	CITROËN 215, 217, 229, 231, 233, 255, 259, 263, 271, 273, 281 PEUGEOT 927, 931, 935, 937, 939, 941, 947, 975, 977, 987	JF150	CITROËN 241, 251 FIAT 351, 377, 389, 393, 405 PEUGEOT 979
JE189	CITROËN 213, 215, 219, 221, 227, 259, 273, 279, 281 PEUGEOT 925, 927, 929, 931, 937, 941, 949, 953, 985, 987	JE744	ALFA ROMEO 7	JE5074	BMW 131, 133, 136, 137, 147, 149, 151, 161, 171	JF184	FIAT 319, 321, 353, 361, 367, 369
JE199	MITSUBISHI 743, 755, 757, 761 PROTON 991	JE747	NISSAN 787, 791, 805, 813, 819, 821, 823	JE5075	AUDI 77, 79, 83, 85 SKODA 1197 VW 1541	JF191	BMW 131, 133, 135, 137, 141, 147, 149, 151, 157, 161, 171, 173
JE231	JAGUAR 552, 553, 555, 557	JE751	ISUZU 521, 523, 525, 527, 529	JE5076	AUDI 53 SEAT 1145, 1147, 1153, 1157, 1163, 1165, 1171 SKODA 1189, 1193 VW 1451, 1459, 1473, 1475, 1477, 1479, 1483, 1495, 1507, 1509, 1517, 1525, 1529, 1531, 1549, 1551	JF205	AUDI 69 SEAT 1141, 1143, 1151, 1157, 1163, 1167, 1173, 1177, 1183 SKODA 1191 VW 1449, 1461, 1463, 1469, 1471, 1475, 1485, 1491, 1503, 1509, 1513, 1535, 1537, 1547, 1551
JE241	LEYLAND / LDV 627 MG 733	JE904	AUDI 59, 95 VW 1487	JF017	MAZDA 645, 649, 657	JF211	AUDI 67 SKODA 1191 VW 1449, 1467
JE248	VOLVO 1385, 1387, 1389, 1393, 1395, 1397, 1399, 1401	JE5012	BMW 133, 137, 143, 147, 151, 157, 169, 173, 175	JF018	NISSAN 783, 791, 793	JH005	NISSAN 781, 785, 787, 789, 795, 801, 803, 821
JE289	LAND ROVER 617 LEYLAND / LDV 629	JE5017	OPEL 829, 849, 851 VAUXHALL 1321, 1353	JF021	HONDA 479, 483, 493, 495, 497 ROVER 1117	JH015	MAZDA 649, 651, 655
JE329	AUSTIN 105	JE5019	BMW 123, 125, 127, 145, 171	JF024	ACURA 3 HONDA 481, 483, 487, 489, 491, 493, 497, 499 ROVER 1105, 1111, 1113	JH016	BEDFORD 113 ISUZU 521, 523, 527, 529 OPEL 847 VAUXHALL 1341
JE331	MG 733 TRIUMPH 1313	JE5020	FORD 459, 463, 467, 473	JF031	NISSAN 807, 811, 817	JH018	TOYOTA 1287
JE388	FIAT 317, 377	JE5021	FORD 413, 417, 419, 421, 431, 433, 447, 449, 453	JF043	FIAT 331	JH021	DAIHATSU 311
JE390	FIAT 325, 351, 373, 375, 403	JE5022	FORD 417, 433, 453	JF046	SUZUKI 1223, 1225, 1227, 1229	JH024	TOYOTA 1265, 1279
JE442	ALFA ROMEO 41	JE5024	OPEL 829, 833, 849, 851, 855, 869, 883 VAUXHALL 1321, 1323, 1353, 1373	JF047	NISSAN 815	JH031	NISSAN 781, 789, 791, 793, 795, 797, 801
JE447	ALFA ROMEO 41	JE5025	FORD 429, 431, 433, 437, 439, 457 MAZDA 635, 637	JF058	TOYOTA 1249, 1255, 1257, 1261, 1271, 1277, 1289, 1299, 1303, 1307, 1309	JH034	MITSUBISHI 745
JE475	FIAT 363, 365	JE5026	MERCEDES-BENZ 665, 681, 685	JF067	CITROËN 215, 279 PEUGEOT 927	JH040	FORD 413 MAZDA 639
JE476	IVECO 535	JE5029	OPEL 841, 849, 857, 887 VAUXHALL 1325, 1331, 1339, 1349, 1353, 1357, 1365, 1367, 1375	JF079	NISSAN 813	JH041	TOYOTA 1257, 1261
JE480	FIAT 317	JE5032	MERCEDES-BENZ 695, 702, 703	JF087	TOYOTA 1251, 1253, 1255, 1257, 1259, 1263, 1265, 1267, 1271, 1273, 1277, 1279, 1281, 1293, 1295, 1297, 1299, 1301, 1303, 1305, 1307	JH050	SUBARU 1215
JE555	BMW 131, 133, 147, 149, 155, 157, 159, 161, 163	JE5034	CHEVROLET 179, 181 DAEWOO 295, 299	JF095	MITSUBISHI 743, 759, 761	JH111	FIAT 317, 325, 377
JE619	DAIHATSU 303 TOYOTA 1253, 1255, 1257, 1261, 1263, 1265, 1267, 1271, 1277, 1279, 1281, 1283, 1287, 1289, 1291, 1293, 1295, 1297, 1299, 1303, 1307, 1309	JE5036	AUDI 67	JF109	SUZUKI 1223, 1225, 1227, 1229	JH170	TOYOTA 1287
JE625	ACURA 3 HONDA 479, 483, 487, 489, 491, 493, 495, 497, 499 ROVER 1105, 1111, 1117 TRIUMPH 1313	JE5037	FORD 437, 439, 441, 447, 449 VOLVO 1409, 1429	JF119	HONDA 483, 487, 491, 493	JH171	HONDA 497, 499 TRIUMPH 1313
JE646	PEUGEOT 963	JE5044	CITROËN 259 PEUGEOT 927			JH310	FIAT 317, 363
JE647	CITROËN 221, 225, 263 FIAT 339 PEUGEOT 923, 939, 963, 965 TALBOT 1241	JE5048	BMW 133			JH370	TRIUMPH 1313, 1315
JE648	RENAULT 1069	JE5050	BMW 121, 125, 129, 133, 167, 173				
JE651	CITROËN 241	JE5060	RENAULT 1049				
JE674	MAZDA 649, 651, 655	JE5061	RENAULT 1043, 1047, 1057, 1085				
JE689	AUDI 51, 53, 55, 57, 61, 63, 65, 67, 73, 83, 85, 87, 93, 95, 97, 99 VW 1507, 1513, 1533	JE5062	RENAULT 1043, 1047, 1057, 1085				
JE696	ALFA ROMEO 7, 9, 11, 27, 31, 33, 37, 41, 43	JE5063	RENAULT 1029, 1041, 1055, 1057, 1061, 1085				
		JE5064	OPEL 841, 883, 893 RENAULT 1035, 1093 SAAB 1135 VAUXHALL 1371, 1377				
		JE5065	SAAB 1131, 1133				
		JE5066	SAAB 1131, 1133				
		JE5067	MERCEDES-BENZ 675, 679, 681, 691				
		JE5068	MERCEDES-BENZ 675, 679, 681, 691				
		JE5069	CITROËN 237, 239 FIAT 401 PEUGEOT 961, 963, 971, 975 RENAULT 1025, 1031, 1051, 1089				

NUMERICAL PARTS LIST









Numerische Teilenummernliste • Liste des références produits
Lista de referencias









							
JH396	LEYLAND / LDV 627 MG 733 MORRIS 775	JH5022	FIAT 345, 347 LAND ROVER 613 ROVER 1107, 1109, 1111, 1113, 1115	JH5082	MERCEDES-BENZ 671, 673, 677, 679, 683, 685, 709, 711, 719, 721	JJ100	ALFA ROMEO 35, 37 FIAT 319, 325, 331, 341, 343, 357 IVECO 535, 537, 541, 545, 547 OPEL 829 RENAULT 1051, 1053, 1091 VAUXHALL 1321
JH409	CARBODIES 177 LAND ROVER 611 LEYLAND / LDV 629	JH5023	AUDI 53 SEAT 1153, 1165, 1171, 1179 SKODA 1189 VW 1459, 1477, 1479, 1509, 1511, 1529, 1531, 1543, 1551	JH5096	OPEL 859 VAUXHALL 1367	JJ104	BMW 131, 133, 137, 147, 149, 151, 171
JH434	LAND ROVER 611, 613, 617 LEYLAND / LDV 629 MG 733 ROVER 1121 TRIUMPH 1315	JH5032	LAND ROVER 615 MG 731 ROVER 1101	JH5097	NISSAN 787, 813, 821, 823	JJ120	BEDFORD 111 OPEL 829, 831, 833, 835, 837, 839, 847, 849, 851, 853, 855, 857, 861, 863, 865, 869, 885, 887 VAUXHALL 1323, 1325, 1327, 1329, 1335, 1337, 1339, 1345, 1347, 1351, 1353, 1354, 1355, 1363, 1365, 1373
JH445	MG 733 TRIUMPH 1313	JH5033	LAND ROVER 615 MG 731 ROVER 1101	JH5098	TOYOTA 1253, 1255, 1259, 1261, 1263, 1295, 1297, 1301	JJ126	DAIHATSU 303, 307, 311
JH485	JAGUAR 553, 555, 557	JH5036	OPEL 829, 833, 849, 851, 855, 869, 883 VAUXHALL 1321, 1323, 1353, 1373	JH5106	JEEP 569	JJ136	FIAT 373, 377
JH494	FIAT 373, 375, 405, 407 ZASTAVA 1555	JH5037	OPEL 829, 849, 851 VAUXHALL 1321, 1353	JH5107	CITROËN 217, 228, 229, 233, 273 PEUGEOT 937, 939, 947, 975, 987	JJ140	AUDI 51, 53, 55, 57, 59, 61, 63, 93, 95, 97 FORD 443 SEAT 1151, 1153, 1155, 1161, 1163, 1165, 1167, 1169, 1177, 1179, 1181 VW 1457, 1459, 1461, 1463, 1467, 1469, 1471, 1473, 1475, 1477, 1479, 1487, 1489, 1491, 1501, 1503, 1505, 1507, 1509, 1525, 1533, 1535, 1541, 1551
JH501	JAGUAR 553, 555, 557	JH5041	NISSAN 795, 807, 809 OPEL 873, 895 RENAULT 1031, 1033, 1043, 1045, 1047, 1049, 1051, 1057, 1059, 1085, 1087, 1089, 1091, 1093 VAUXHALL 1361, 1377, 1379 VOLVO 1409, 1427	JH5108	RENAULT 1027, 1029, 1041, 1045, 1053, 1055, 1057, 1061, 1083, 1085, 1087	JJ149	MAZDA 639, 641, 653
JH526	ALFA ROMEO 39, 41	JH5046	FORD 429, 445	JH5109	NISSAN 795, 799, 801 RENAULT 1027, 1029, 1041, 1055, 1061, 1084, 1085, 1087	JJ150	TOYOTA 1279, 1281, 1285, 1289
JH565	ALFA ROMEO 7, 9, 31, 33 NISSAN 791	JH5049	BMW 143, 153, 157, 163, 169 LAND ROVER 617	JH5111	BMW 167	JJ151	NISSAN 803
JH683	MERCEDES-BENZ 681, 687, 689, 697, 699, 715, 717, 719	JH5050	BMW 123, 127, 171	JH5112	BMW 123, 125	JJ163	SUZUKI 1223, 1225
JH881	LADA 579, 581	JH5051	CHRYSLER 185, 187 MINI 737	JH5113	MERCEDES-BENZ 695, 705, 707	JJ177	SUZUKI 523
JH901	IVECO 535	JH5052	OPEL 847, 893 SAAB 1127, 1131 VAUXHALL 1343, 1351	JH5115	BMW 157, 159, 163, 165, 167, 171	JJ183	SEAT 1151, 1157, 1159, 1163, 1175 VW 1457, 1465, 1469, 1487, 1517, 1519, 1521, 1523, 1527, 1547
JH5002	CITROËN 249, 257 FIAT 343, 345, 347 IVECO 535, 537, 539, 541, 543, 545, 547, 549 PEUGEOT 979	JH5056	BMW 167	JH5116	BMW 157, 159, 163, 165, 167	JJ184	AUDI 55, 57, 59, 61, 63, 65, 67, 87, 89, 93, 95, 97, 99 VW 1513, 1515, 1533
JH5005	BEDFORD 111 DAEWOO 291, 293, 295 OPEL 829, 831, 833, 835, 837, 839, 847, 849, 851, 853, 855, 857, 861, 863, 865, 869, 885, 887 VAUXHALL 1323, 1325, 1327, 1329, 1335, 1337, 1339, 1345, 1347, 1351, 1353, 1354, 1355, 1363, 1365, 1373	JH5057	OPEL 843, 845, 875, 881, 883, 889, 891, 893, 897 SAAB 1133 VAUXHALL 1333, 1337, 1367, 1371, 1375, 1377, 1381	JH5117	AUDI 67, 69, 83, 101 SEAT 1141, 1151, 1161, 1171, 1173, 1177 SKODA 1191 VW 1449, 1453, 1467, 1475, 1477, 1483, 1499, 1501, 1503, 1525, 1535	JJ187	SUZUKI 1221, 1223
JH5008	FORD 437, 439, 469, 475	JH5058	ISUZU 525, 527, 529 OPEL 855, 863 VAUXHALL 1325, 1339, 1355, 1365, 1367	JJ023	TOYOTA 1291	JJ192	ISUZU 521, 523, 527, 529 SSANGYONG 1205 VAUXHALL 1341
JH5011	VOLVO 1389, 1391, 1393, 1411, 1429	JH5059	VW 1463, 1487, 1517, 1539, 1547, 1553	JJ057	PEUGEOT 939	JJ200	BEDFORD 111, 113 OPEL 831, 839, 863, 865, 867, 869, 879, 887 VAUXHALL 1327, 1329, 1331, 1337, 1339, 1341, 1343, 1347, 1349
JH5012	LAND ROVER 615 MG 729, 731 ROVER 1097, 1099, 1109, 1113, 1121	JH5060	CHRYSLER 185, 187, 189	JJ065	VOLVO 1385, 1387, 1389, 1393, 1395, 1397, 1399, 1401	JJ204	BEDFORD 113 ISUZU 521, 523, 525, 527 VAUXHALL 1361
JH5013	BMW 161, 163 FORD 443 VW 1463, 1487, 1517, 1539, 1553	JH5061	FORD 413, 439, 441, 445, 447, 449, 469, 475 MAZDA 657	JJ072	HYUNDAI 507, 509 MITSUBISHI 745, 747, 751, 753, 755, 763, 767, 769, 773	JJ214	FIAT 341, 343, 347 IVECO 537, 547, 549
JH5014	LAND ROVER 611, 613	JH5065	FORD 413, 451	JJ075	MITSUBISHI 741, 743, 745, 747, 749, 759, 761, 767, 771, 773	JJ250	TOYOTA 1283
JH5015	FORD 415, 427, 429, 445 MAZDA 637	JH5070	BMW 121, 131, 149, 167	JJ078	FIAT 317, 347, 349, 365, 367, 403, 405 LANCIA 603		
JH5016	MG 729 ROVER 1097, 1101, 1103, 1105, 1109, 1119, 1121	JH5077	FIAT 341	JJ080	SAAB 1125, 1127, 1129, 1131, 1133		
JH5019	OPEL 859, 877 VAUXHALL 1345, 1359	JH5081	FIAT 341 IVECO 543	JJ089	BMW 123, 125, 133, 145		
				JJ093	TOYOTA 1287		
				JJ094	DAIHATSU 303 TOYOTA 1265, 1267, 1293, 1303, 1305, 1307		
				JJ098	MITSUBISHI 743, 755, 757, 761 PROTON 991		

											
JJ265	NISSAN	781, 787, 791, 793, 795, 807, 811, 813, 815, 819		JJ454	ISUZU	521, 523, 529	JJ535	FIAT	319, 321, 323, 327, 355, 371		
JJ268	KIA	573, 575, 577			OPEL	859		LANCIA	585, 593		
	MAZDA	645, 647, 649, 651, 653, 657	JJ365	HONDA	497	JJ455	FORD	463	JJ536	BMW	139, 153, 155, 161
JJ271	HONDA	479, 497, 499	JJ366	FIAT	391, 395, 397	JJ456	FORD	421, 423, 425, 435, 437, 449, 455, 457, 465		JEEP	565
JJ273	BEDFORD	115		LANCIA	587	JJ457	FORD	443, 459, 467, 471		LAND ROVER	615
	SUZUKI	1225, 1227	JJ367	NISSAN	781, 787, 789, 795, 807, 813, 815	JJ458	FORD	413, 461, 463, 467, 473		OPEL	877
JJ274	MITSUBISHI	745, 749, 753, 763, 767, 771, 773	JJ368	NISSAN	781, 787, 789, 807, 813, 815	JJ459	DAEWOO	295, 297	JJ537	BMW	123, 125, 127, 145
JJ277	TOYOTA	1291	JJ376	ISUZU	523		LADA	579	JJ538	BMW	157, 163, 165
JJ281	NISSAN	789, 793, 803, 805, 821	JJ385	DAEWOO	291, 297		OPEL	843, 845, 859, 867, 883, 889, 891	JJ543	MERCEDES-BENZ	667, 673, 675, 679, 687, 689, 697, 701, 713, 715, 717, 719
JJ283	CITROËN	217, 219, 221, 223, 225, 227, 231, 241, 243, 245, 247, 249, 251, 253, 255, 259, 261, 265, 267, 269, 273, 275, 277, 281, 283		OPEL	831, 833, 845, 859, 865, 867, 869, 873, 875, 879, 887, 889, 891		VAUXHALL	1335, 1341, 1351, 1357, 1359, 1371		SSANGYONG	1205, 1207
	FIAT	339, 379, 397, 399, 401	JJ386	MAZDA	657	JJ463	FORD	421, 423, 425, 435, 449, 455, 457, 465	JJ549	LANCIA	599, 601
	HONDA	491	JJ389	SUBARU	1213, 1215, 1217		MAZDA	639		RENAULT	1083
	LADA	579	JJ390	HONDA	497	JJ470	ISUZU	523	JJ551	VOLVO	1385, 1395, 1397, 1401
	LANCIA	607	JJ398	ALFA ROMEO	15, 17, 19		OPEL	847	JJ555	VAUXHALL	847, 871
	LEYLAND / LDV	623, 625		FIAT	321, 323, 337, 349, 351, 361, 371, 373, 375, 377, 387, 389, 391, 395, 397, 405, 407		VAUXHALL	1341	JJ557	OPEL	829
	PEUGEOT	933, 935, 939, 941, 943, 945, 947, 951, 953, 955, 957, 959, 961, 967, 969, 971, 973, 977, 979, 981, 983, 987, 989	JJ404	ROVER	1097, 1101, 1103, 1105, 1109, 1119, 1121	JJ471	FIAT	317, 325		RENAULT	1029, 1031, 1033, 1037, 1039, 1041, 1045, 1047, 1057, 1059, 1065, 1067, 1069, 1073, 1075, 1081, 1085
	ROVER	1107, 1111	JJ407	RENAULT	1025, 1027, 1037, 1039, 1071, 1081	JJ484	FORD	473		VAUXHALL	1321
	SUZUKI	1221, 1227, 1231	JJ412	LADA	579, 581	JJ488	MERCEDES-BENZ	665, 681, 683, 685, 715, 717, 719	JJ558	JEEP	563, 565, 569
	TALBOT	1239	JJ413	ALFA ROMEO	21, 27		LEYLAND / LDV	625		PEUGEOT	965
JJ298	ALFA ROMEO	15, 17, 19		FIAT	327, 329, 331, 373, 389, 391, 393, 395, 397, 405, 407	JJ491	MERCEDES-BENZ	689, 691, 693, 699, 701, 703, 705, 707		RENAULT	1033, 1035, 1041, 1051, 1071, 1075, 1077, 1079, 1081, 1083, 1089, 1091
	FIAT	321, 323, 329, 331, 337, 349, 351, 361, 371, 373, 375, 377, 387, 389, 391, 393, 395, 397, 405, 407	JJ429	NISSAN	811, 817	JJ498	MERCEDES-BENZ	665, 671, 673, 681, 683, 685, 711, 713, 715, 717, 719, 723	JJ559	RENAULT	1033, 1075, 1077, 1079, 1081, 1083
	LANCIA	585, 587, 589, 597, 599	JJ430	NISSAN	811, 817		SSANGYONG	1205, 1207		RENAULT	1035, 1075, 1077, 1079
JJ299	NISSAN	781, 783, 791, 793, 797, 801, 813	JJ435	DAIHATSU	303, 309, 311	JJ499	MERCEDES-BENZ	669, 671, 673, 677, 679, 683, 685, 687, 701, 709, 711, 713, 719, 723	JJ562	RENAULT	1035, 1075, 1077, 1079
JJ309	HONDA	483, 485, 487, 489, 491, 493, 495, 499	JJ440	FIAT	317, 349, 365, 367, 403, 405		SSANGYONG	1205, 1207	JJ565	RENAULT	1025, 1043, 1087, 1091
	ROVER	1103, 1105, 1109	JJ446	LAND ROVER	613	JJ500	DAEWOO	293, 295	JJ568	RENAULT	1035, 1049, 1083
JJ315	AUSTIN	105, 109		ROVER	1107, 1109, 1111, 1113, 1115		MERCEDES-BENZ	675, 677, 689, 691, 693, 695, 697, 699, 703, 705, 707	JJ572	OPEL	847, 877, 883, 893
	LEYLAND / LDV	623, 625, 627	JJ449	FIAT	327, 363, 381	JJ501	AUDI	55, 57, 63, 65, 87, 97, 99		VAUXHALL	1343, 1369, 1371, 1377
	MG	727, 735	JJ450	ALFA ROMEO	7, 13, 15		VOLVO	1399, 1419, 1423, 1437	JJ573	OPEL	847, 877, 883, 893
	ROVER	1107, 1113, 1115, 1119	JJ451	ALFA ROMEO	9, 27		VW	1493		VAUXHALL	1343, 1369, 1371, 1377
JJ317	FIAT	331	JJ452	ALFA ROMEO	9, 11, 31, 33, 37, 39, 41, 43	JJ508	OPEL	877, 881	JJ574	OPEL	841
JJ322	TOYOTA	1265, 1279	JJ453	CITROËN	241, 251		VAUXHALL	1345, 1369		VAUXHALL	1331, 1337
JJ334	FORD	417, 433, 453		FIAT	319, 323, 351, 355, 359, 361, 369, 373, 375, 377, 383, 387, 389, 391, 393, 403, 405, 407	JJ515	ALFA ROMEO	11, 29	JJ575	OPEL	835, 837, 839, 853, 855, 857, 885, 887, 895
JJ341	SUZUKI	1221, 1223, 1227, 1229, 1233		FIAT	327, 363, 381	JJ519	ALFA ROMEO	35, 37		VAUXHALL	1323, 1325, 1327, 1329, 1337, 1355, 1373, 1379
JJ343	TOYOTA	1269, 1293		LANCIA	585, 589, 593		CITROËN	249	JJ586	VW	1463, 1485, 1513, 1551
JJ345	ISUZU	523, 525		PEUGEOT	979		FIAT	343, 345, 347		CITROËN	213, 215, 219, 221, 227, 257, 259, 279, 281
JJ348	FORD	415, 417, 419, 429, 431, 451, 453, 463		ZASTAVA	1555		IVECO	535, 537, 539, 541, 543, 547, 549		PEUGEOT	925, 927, 929, 931, 941, 949, 953, 985, 987
JJ354	KIA	575					OPEL	873	JJ587	CITROËN	213, 215, 227, 259, 273, 279, 281
	MAZDA	637, 641, 643					RENAULT	1025, 1051, 1053, 1091		NISSAN	799
JJ358	BEDFORD	113					VAUXHALL	1363		PEUGEOT	927, 931, 937, 941, 949
	ISUZU	521, 531								ROVER	1103
	OPEL	847								CITROËN	249, 257, 271
	VAUXHALL	1341, 1361								PEUGEOT	969, 979
JJ360	SUBARU	1211, 1215, 1217								FIAT	327, 363, 381

NUMERICAL PARTS LIST









Numerische Teilenummernliste • Liste des références produits
Lista de referencias









																																																																																
JJ609	AUDI 53, 55, 77, 79, 85, 93 SEAT 1141, 1143, 1147, 1153, 1155, 1157, 1163, 1165, 1167, 1171, 1181, 1183 VW 1457, 1461, 1463, 1469, 1471, 1479, 1483, 1485, 1497, 1503, 1511, 1513, 1525, 1527, 1529, 1531, 1533, 1537, 1543, 1549, 1551	JM302	AUSTIN 105, 107, 109 MG 727, 733 MORRIS 775 ROVER 1117, 1119 JM315	LEYLAND / LDV 627, 629 MG 733 MORRIS 775 JM333	FIAT 317, 349, 363, 365, 401 SEAT 1157, 1175 ZASTAVA 1555 JM350	AUSTIN 107 CARBODIES 177 LAND ROVER 611 JM356	LAND ROVER 611 JM413	BEDFORD 113 JM447	JAGUAR 553, 555 JM448	JAGUAR 553, 555 JM460	FORD 413, 419 LOTUS 631 JM477	TRIUMPH 1313, 1315 JM478	FORD 413, 419 JM483	LAND ROVER 611, 613, 617 LEYLAND / LDV 629 MG 733 ROVER 1121 TRIUMPH 1315 JM508	FIAT 317, 377 JM510	FORD 413, 419, 427, 445, 463, 465, 469 JM536	JAGUAR 553, 555, 557 JM537	JAGUAR 553, 555, 557 JM550	BEDFORD 113 VAUXHALL 1379 JM654	FIAT 351, 369, 373, 375, 383, 387, 389, 393, 403, 405 ZASTAVA 1555 JM658	IVECO 535 JM663	FIAT 373, 375, 405, 407 ZASTAVA 1555 JM669	ALFA ROMEO 7, 31, 33 NISSAN 791 JM674	FIAT 317, 363 JM848	BMW 123, 125 MERCEDES-BENZ 665, 681, 687, 697, 699, 715, 717, 719 JM875	FORD 413, 445, 461, 467 JM950	LADA 579 OPEL 843, 845, 867, 889, 891 VAUXHALL 1335, 1341, 1351 JM956	OPEL 871, 881 VAUXHALL 1369 JM986	VW 1541, 1543 JM2052	SEAT 1157, 1161, 1175 JM5000	LAND ROVER 613, 617 JM5002	ALFA ROMEO 13, 15, 17, 19, 21, 23, 25, 29, 39, 41, 43 JM5003	FIAT 333, 361, 371, 387 JM5006	NISSAN 741 JM5016	FORD 437, 439, 469, 475 JM5018	FIAT 325, 327, 357, 387 LANCIA 591, 595 JM5019	FIAT 333, 359, 361, 365, 369, 381, 383, 387 LANCIA 601, 605 JM5022	NISSAN 743, 757 JM5023	ALFA ROMEO 29, 43, 45 JM5024	ALFA ROMEO 29, 43, 45 FIAT 321, 323 JM5027	FORD 473 LEYLAND / LDV 625 JM5028	ALFA ROMEO 17, 23 FIAT 321, 323, 335, 355, 359, 371, 385, 387 LANCIA 595 JM5029	ALFA ROMEO 25, 31 LANCIA 595, 601 JM5030	FORD 443 VW 1463, 1487, 1517, 1539, 1553 JM5034	LAND ROVER 611, 613 JM5035	LAND ROVER 615 MG 731 ROVER 1099, 1101 JM5037	FORD 449, 471 JM5045	LAND ROVER 613 ROVER 1107, 1109, 1111, 1113, 1115 JM5046	HONDA 479, 481 ROVER 1113 JM5048	OPEL 829, 833, 851 VAUXHALL 1321, 1353 JM5059	OPEL 835, 837, 839, 853, 871, 885, 887, 895 VAUXHALL 1323, 1327, 1355, 1359, 1373, 1379 JM5063	BMW 139, 153, 155, 161 JM5064	NISSAN 783 JM5071	OPEL 829, 833, 849, 851, 853, 855, 869, 883, 895 SUZUKI 1231 VAUXHALL 1321, 1323, 1353, 1355, 1359, 1373 JM5072	TOYOTA 1309, 1311 JM5073	TOYOTA 1251, 1261, 1267, 1269, 1271, 1273, 1295, 1301 JM5074	LAND ROVER 611, 613 JM5076	LAND ROVER 615 MG 731 ROVER 1101 JM5078	ISUZU 529 VAUXHALL 1359, 1361 JM5085	OPEL 829, 851 VAUXHALL 1321, 1353 JM5086	NISSAN 741, 769 NISSAN 795, 807, 809 OPEL 873 RENAULT 1031, 1033, 1043, 1045, 1047, 1051, 1057, 1059, 1085, 1089 VAUXHALL 1361 VOLVO 1409, 1427 JM5087	CITROËN 219, 237, 239, 243, 245, 247, 253, 257, 261, 267, 279 FIAT 381, 399, 401 LANCIA 607 PEUGEOT 937, 945, 949, 959, 961, 969, 973, 979, 983, 989 JM5088	CITROËN 219, 229, 243, 251, 275 FIAT 379 PEUGEOT 937, 943, 981, 989 TOYOTA 1275 JM5089	CITROËN 219, 229, 243, 251, 275 FIAT 379 OPEL 895 PEUGEOT 937, 943, 981, 989 TOYOTA 1275 VAUXHALL 1377 JM5092	OPEL 841, 857, 871, 881, 885, 887, 889, 895 SAAB 1131 VAUXHALL 1331, 1357, 1361, 1373, 1375, 1379 JM5094	OPEL 847, 877, 883, 893 SAAB 1127, 1131 VAUXHALL 1343, 1351, 1369, 1371 JM5095	OPEL 847, 877, 883, 893 SAAB 1127, 1131 VAUXHALL 1343, 1351, 1369, 1371 JM5096	BMW 159, 161, 171 JM5097	BMW 159, 161, 171 JM5098	BMW 171 JM5099	FORD 443 VW 1463, 1487, 1517, 1539, 1553 JM5103	SEAT 1143, 1155 SKODA 1195 VW 1453, 1461, 1483, 1485, 1499, 1501, 1537, 1543 JM5104	FORD 429, 445 JM5106	BMW 141, 143, 153, 155, 157, 163, 169, 171 LAND ROVER 617 OPEL 877 VAUXHALL 1369 JM5107	BMW 157, 159, 163, 165, 167 JM5108	BMW 157, 159, 163, 165, 167 JM5109	BMW 157, 159, 163, 165, 167 JM5111	MERCEDES-BENZ 669, 671, 673, 677, 679, 683, 685, 687, 701, 709, 711, 713, 723 JM5112	MERCEDES-BENZ 671, 673, 683, 685 JM5113	MERCEDES-BENZ 691, 693, 703, 707

							
JM5114	MERCEDES-BENZ 675, 677, 689, 693, 695, 699, 703, 705, 707	JM5184	FORD 413, 439, 441, 445, 447, 449, 469, 475	JM5283	CITROËN 235, 237, 239, 243, 245, 253, 261, 277	JM7028	JEEP 567
JM5115	MERCEDES-BENZ 675, 689, 691, 693, 695, 699, 703		MAZDA 657		FIAT 381, 397, 399		MERCEDES-BENZ 675, 679, 689, 697, 701, 712, 713
JM5118	BMW 129, 149	JM5185	RENAULT 1027, 1043, 1091		LANCIA 597, 605	JM7029	AUDI 79, 85
JM5119	CHRYSLER 185, 187, 189	JM5196	KIA 575		PEUGEOT 937, 947, 957, 959, 961, 963, 969, 971, 973, 975	JM7030	AUDI 79, 85
	MINI 737	JM5197	OPEL 839, 849, 857, 871	JM5285	SEAT 1145		VW 1513
JM5120	HONDA 485	JM5198	OPEL 839, 857, 871		SKODA 1187, 1189	JM7031	AUDI 73
	SEAT 1165, 1167		VAUXHALL 1329, 1337, 1357, 1361		VW 1495		MINISUBISHI 751, 763
JM5121	OPEL 829, 849	JM5201	FIAT 341	JM5286	JEEP 565, 567, 569		SEAT 1143, 1175, 1181
	VAUXHALL 1321, 1353		IVECO 543	JM5287	MAZDA 641		SKODA 1195
JM5131	RENAULT 1025, 1043, 1087, 1091	JM5202	FIAT 341	JM5288	MINI 737	JM7032	AUDI 67
JM5134	HONDA 483	JM5203	AUDI 69, 77, 79, 83		TOYOTA 1311		SEAT 1145, 1149, 1159
JM5135	HONDA 485, 491, 493		FORD 443	JM5289	MINISUBISHI 761		SKODA 1187, 1197
JM5137	NISSAN 785, 805, 811, 823		SEAT 1141, 1143, 1153, 1155, 1167, 1173, 1179, 1181	JM5290	MINISUBISHI 749, 759, 763		VW 1465, 1497, 1523
JM5138	NISSAN 785, 809, 819		SKODA 1187, 1193, 1197	JM5291	MINISUBISHI 749, 759, 763	JM7034	CITROËN 217, 233, 235, 273
JM5139	CITROËN 235, 237, 239, 243, 245, 253, 261, 277		VW 1453, 1459, 1461, 1481, 1483, 1485, 1491, 1497, 1499, 1511, 1515, 1531, 1535, 1537, 1539, 1543	JM5292	MINISUBISHI 765, 767		FORD 433, 439, 441
	FIAT 381, 397, 399	JM5204	ALFA ROMEO 17, 23	JM5293	FORD 447, 451		MAZDA 635
	LANCIA 597, 605		FIAT 335, 355, 359, 371, 385, 387		NISSAN 783		MINI 737
	PEUGEOT 937, 947, 957, 959, 961, 963, 969, 971, 973, 975		LANCIA 595	JM5294	FORD 447, 451	JM7035	CITROËN 217, 229, 233, 273
JM5141	CITROËN 237, 239		OPEL 840, 841, 881, 889, 897		NISSAN 783		PEUGEOT 937, 939, 947, 975, 987
	FIAT 399, 401	JM5205	VAUXHALL 1371, 1375, 1379	JM5295	KIA 575	JM7036	TOYOTA 1253, 1255, 1301
	LANCIA 597, 607		AUDI 67, 73	JM5296	KIA 575, 577	JM7037	INFINITI 517
	PEUGEOT 949, 959, 961, 971, 973, 975, 983		IVECO 543		MAZDA 655, 657		NISSAN 797
JM5146	TOYOTA 1251, 1261, 1275, 1293, 1299		SEAT 1143, 1171, 1177	JM5298	NISSAN 799	JM7038	KIA 573, 577
JM5148	TOYOTA 1251, 1275, 1277, 1299, 1301, 1307		SKODA 1191	JM5299	FORD 431, 441	JM7039	MINISUBISHI 751
JM5149	DAIHATSU 307, 309, 311		VW 1449, 1457, 1467, 1469, 1489, 1499, 1501, 1503, 1539		MAZDA 635	JM7041	MINISUBISHI 747, 751, 763
	TOYOTA 1309, 1311	JM5232	MINISUBISHI 769	JM5300	HONDA 495	JM7042	CITROËN 225
JM5153	FORD 437, 439, 441, 447, 449		VOLVO 1409, 1427	JM5301	DAIHATSU 305, 307, 309, 311		DAIHATSU 305, 309
	VOLVO 1409, 1429	JM5234	VW 1453, 1485, 1501, 1515	JM5302	DAEWOO 291		PEUGEOT 929
JM5154	FORD 413, 439, 441, 447, 449	JM5235	OPEL 835, 869, 885, 895	JM5303	CHEVROLET 179	JM7045	TOYOTA 1253, 1297, 1309, 1311
JM5155	FORD 427, 429, 431, 433, 437, 439, 441, 457		VAUXHALL 1325, 1359, 1373, 1379	JM5304	DAEWOO 291, 293, 297		AUDI 73, 101
JM5157	MERCEDES-BENZ 671, 673, 675, 683, 685, 687, 693, 699	JM5236	MERCEDES-BENZ 673, 675, 679, 687, 689, 695, 699, 701, 703, 705, 707, 709, 721, 723	JM5305	SUZUKI 1221, 1223, 1231		FORD 445
JM5158	FORD 437, 447, 449	JM5237	MERCEDES-BENZ 673, 675, 679, 687, 689, 695, 699, 701, 703, 705, 707, 709, 721, 723	JM5306	HYUNDAI 503, 507, 509, 511	JM7046	AUDI 81, 89, 91, 99
	VOLVO 1409, 1429		NISSAN 783	JM5307	KIA 575		VW 1517, 1539
JM5159	OPEL 843, 845, 859, 875, 881, 883, 889, 891, 893, 897	JM5245	NISSAN 783	JM5308	SUZUKI 1223, 1225, 1231	JM7047	AUDI 81, 89, 91, 99
	SAAB 1133	JM5247	CHRYSLER 189	JM5309	SUZUKI 1231		VW 1517, 1539
	VAUXHALL 1333, 1337, 1357, 1367, 1371, 1375, 1377, 1381	JM5259	FIAT 333, 353, 367, 369	JM5310	KIA 573	JM7048	AUDI 71, 79
JM5162	SMART 1201		LANCIA 595, 605	JM5311	MAZDA 635		VW 1485, 1539
JM5163	MERCEDES-BENZ 667, 719		OPEL 829, 833, 847, 853, 883	JM5312	SUZUKI 1223, 1225, 1227, 1233	JM7049	CHRYSLER 191
JM5164	MERCEDES-BENZ 667, 719		SUZUKI 1225, 1229, 1233	JM5314	MAZDA 637, 655	JM7050	JEEP 569
JM5165	MERCEDES-BENZ 667, 719		VAUXHALL 1323, 1353, 1373	JM5315	MAZDA 645, 647, 657	JM7051	CITROËN 229, 231, 233
JM5166	AUDI 57, 65, 81, 89, 91, 93, 99	JM5263	CHEVROLET 179, 181	JM5316	INFINITI 517		PEUGEOT 935, 937, 947, 975
JM5167	BMW 121, 131, 149, 167		DAEWOO 295, 299		NISSAN 783, 801	JM7052	CITROËN 229, 231, 233
JM5176	FIAT 319, 321, 353, 359, 367, 369, 383	JM5267	NISSAN 823	JM5317	INFINITI 517		PEUGEOT 935, 937, 947, 975
	LANCIA 603, 605	JM5277	HYUNDAI 503, 507, 509, 511		NISSAN 783, 801	JM7053	CITROËN 229, 231, 233
JM5181	FIAT 359, 365, 369, 383, 387	JM5279	MINISUBISHI 765	JM5318	NISSAN 803, 819		PEUGEOT 935, 937, 947, 975
		JM5281	NISSAN 799	JM5319	MAZDA 641	JM7054	RENAULT 1027, 1059, 1091
		JM5282	NISSAN 813, 823	JM5320	KIA 573, 575, 577		NISSAN 795, 799, 801
				JM7022	TOYOTA 1251		RENAULT 1027, 1029, 1041, 1043, 1045, 1051, 1055, 1061, 1083, 1085, 1087, 1093
				JM7023	TOYOTA 1285, 1287, 1291		
				JM7024	TOYOTA 1305		
				JM7026	MERCEDES-BENZ 669, 677, 681, 709		
				JM7027	MERCEDES-BENZ 667, 669		

NUMERICAL PARTS LIST









Numerische Teilenummernliste • Liste des références produits
Lista de referencias









							
JM7055	ALFA ROMEO 19, 23, 25, 27, 39 FIAT 325, 329, 385 OPEL 841, 881, 889, 897 SAAB 1131, 1133 VAUXHALL 1333, 1371, 1375, 1379	JN344	BEDFORD 111 OPEL 829, 831, 851, 853, 861, 869 VAUXHALL 1323, 1345, 1363, 1365	JN469	TOYOTA 1253, 1255, 1261, 1265, 1277, 1279, 1281, 1309	JN568	FIAT 375, 377 LANCIA 589
JN041	BEDFORD 113 OPEL 869, 871, 879 VAUXHALL 1343, 1345, 1369	JN356	DAIHATSU 305 TOYOTA 1257, 1267, 1269, 1279, 1303, 1307	JN494	NISSAN 791, 793, 795, 811, 815	JN570	NISSAN 781, 783, 791, 793, 797, 801, 805, 813
JN068	OPEL 851, 861, 869 VAUXHALL 1321, 1363	JN365	NISSAN 741, 743, 745, 747, 749, 759, 761, 767, 771, 773	JN496	NISSAN 745, 749, 751, 753, 755, 763, 767, 771, 773	JN572	MERCEDES-BENZ 665, 671, 681, 683, 711, 713, 715, 717, 719, 721, 723
JN105	FORD 415, 427, 429, 445, 451 MAZDA 637	JN369	RENAULT 1063	JN504	ISUZU 523	JN574	HONDA 483, 499
JN106	FORD 471	JN396	MAZDA 639, 641, 653	JN512	TRIUMPH 1313	JN576	KIA 573, 577 MAZDA 647, 651, 653, 657
JN180	JAGUAR 553, 555	JN403	HYUNDAI 507, 509, 513 MITSUBISHI 745, 747, 751, 753, 755, 763, 767, 769	JN513	SAAB 1125	JN578	BMW 137, 149
JN185	TOYOTA 1263, 1265, 1287, 1289, 1299	JN404	HONDA 483	JN521	BEDFORD 113 OPEL 875, 877, 879, 881 VAUXHALL 1345, 1369	JN579	SUZUKI 1225, 1227
JN191	ISUZU 521, 527	JN405	DAIHATSU 307, 309	JN523	BEDFORD 113 OPEL 875, 877, 879 VAUXHALL 1345, 1369	JN580	HONDA 483, 485, 493, 495
JN232	CITROËN 213, 245, 253, 255, 261	JN408	BEDFORD 113 ISUZU 521, 523, 527, 529 OPEL 847 SSANGYONG 1205 VAUXHALL 1341	JN528	NISSAN 793, 811, 819	JN581	ALFA ROMEO 7, 11, 13, 35, 39 LAND ROVER 615 ROVER 1121 TOYOTA 1289
JN234	CITROËN 241	JN410	TOYOTA 1257	JN532	TOYOTA 1253, 1255, 1259, 1271, 1273, 1275, 1277, 1293, 1307, 1309	JN583	TRIUMPH 1313
JN238	CITROËN 225, 227 PEUGEOT 929, 931, 949 TALBOT 1237, 1239, 1241, 1243	JN414	BEDFORD 115 SUZUKI 1223, 1225, 1227	JN533	KIA 577 MAZDA 645, 647, 649, 651	JN585	FIAT 331
JN244	CITROËN 231 FIAT 339 PEUGEOT 963, 965, 967, 983, 985	JN415	DAIHATSU 303, 307, 311	JN536	TOYOTA 1291	JN587	FIAT 403 LANCIA 603
JN245	FORD 445, 459, 461, 467 LEYLAND / LDV 623, 625 PEUGEOT 963, 965, 967, 985 SSANGYONG 1205 TALBOT 1243	JN416	NISSAN 789, 803, 805, 821	JN539	JAGUAR 553, 555, 557	JN588	ALFA ROMEO 7, 13, 31, 33 NISSAN 791
JN248	DACIA 287 RENAULT 1061, 1063, 1065, 1069, 1081 VOLVO 1385, 1387	JN417	FIAT 317, 349, 365, 367, 403, 405	JN542	BMW 149, 155, 157, 159, 161, 163, 165	JN591	TOYOTA 1257, 1267, 1269, 1279, 1303, 1307
JN251	RENAULT 1061	JN426	CITROËN 231, 233, 241 FIAT 317 PEUGEOT 985	JN544	CITROËN 217, 219, 223, 225, 227, 231, 241, 243, 245, 247, 251, 253, 255, 261, 265, 267, 273, 275, 277, 281, 283 FIAT 337, 339, 379, 397 HONDA 491 LADA 579 LEYLAND / LDV 623, 625 PEUGEOT 933, 935, 941, 943, 945, 951, 953, 955, 957, 959, 971, 977, 981, 983, 987, 989	JN594	ALFA ROMEO 35, 37 FIAT 319, 325, 331, 335, 341, 343, 345, 347, 357 IVECO 535, 537, 539, 541, 543, 545, 547, 549 RENAULT 1051, 1053, 1091
JN253	CITROËN 233, 241	JN427	MITSUBISHI 753, 763, 767, 773	JN547	CITROËN 221, 223, 245, 247, 249, 255, 259, 261, 263, 267, 269, 281, 283 FIAT 339, 397, 401 LANCIA 607 PEUGEOT 933, 935, 939, 941, 951, 953, 955, 961, 967, 969, 971, 973, 979, 981	JN595	MAZDA 639, 651, 653, 657
JN273	MERCEDES-BENZ 689, 697, 715, 717	JN433	NISSAN 781, 787, 791, 795, 807, 813, 815	JN549	AUSTIN 109 ROVER 1105	JN596	CITROËN 221, 225, 227, 255, 263 FIAT 343 PEUGEOT 923, 925, 929, 931 TALBOT 1241
JN279	VOLVO 1385, 1389	JN434	HONDA 483, 497, 499	JN551	DAIHATSU 307, 309 TOYOTA 1249, 1281, 1283, 1285, 1287, 1293, 1295, 1303, 1305, 1307	JN597	NISSAN 803
JN283	FIAT 317, 347, 349, 403 TALBOT 1237	JN438	AUDI 55, 57, 59, 61, 63, 65, 67, 99 VW 1513, 1515, 1533	JN553	MAZDA 653	JN598	TOYOTA 1267, 1269, 1283, 1303, 1305, 1307
JN285	SAAB 1125	JN440	SUZUKI 1221, 1223	JN555	RENAULT 1067 VOLVO 1393, 1411	JN599	MITSUBISHI 745, 749, 759, 761, 767, 771
JN292	CITROËN 239 JEEP 565, 569 PEUGEOT 965 RENAULT 1033, 1035, 1041, 1051, 1071, 1075, 1077, 1079, 1081, 1083, 1089, 1091	JN453	BEDFORD 111 OPEL 831, 863, 865, 867, 869, 879 VAUXHALL 1327, 1329, 1331, 1339, 1341, 1343, 1347, 1349	JN562	HONDA 483, 485, 495, 499 ROVER 1103	JN600	RENAULT 1025, 1035, 1037, 1039, 1041, 1063, 1065, 1067, 1071, 1075, 1079, 1089
JN297	BMW 131, 133, 137, 147, 149, 151, 171	JN454	MERCEDES-BENZ 665, 681, 683, 685, 697, 715, 717, 719	JN564	NISSAN 799	JN603	TOYOTA 1257, 1261, 1269, 1271, 1277, 1293, 1295, 1303, 1305, 1309
JN299	BMW 123, 125, 145	JN456	BEDFORD 113 ISUZU 521, 523, 525, 527 VAUXHALL 1361	JN567	TOYOTA 1279, 1281, 1285, 1287, 1289	JN604	TOYOTA 1257, 1261, 1269, 1271, 1277, 1293, 1295, 1303, 1305, 1309
JN300	BMW 159, 161, 163	JN459	ALFA ROMEO 15, 17, 19 FIAT 321, 323, 337, 349, 351, 361, 371, 373, 377, 387, 389, 391, 395, 397, 405, 407	JN568	NISSAN 799	JN605	HONDA 479, 497, 499
JN302	RENAULT 1079	JN460	FORD 471, 473	JN570	NISSAN 799	JN606	SUZUKI 1223, 1225, 1227, 1229
JN303	RENAULT 1079	JN462	ALFA ROMEO 35, 37 FIAT 319, 325, 331, 335, 341, 343, 357 IVECO 537, 547 RENAULT 1051, 1053, 1091	JN572	TOYOTA 1279, 1281, 1285, 1287, 1289	JN607	MERCEDES-BENZ 665, 681, 683, 685, 697, 715, 717, 719
JN317	MITSUBISHI 743, 755, 757, 761 PROTON 991			JN574	TOYOTA 1279, 1281, 1285, 1287, 1289	JN610	SUBARU 1211, 1215, 1217
JN318	HONDA 497, 499			JN576	TOYOTA 1279, 1281, 1285, 1287, 1289	JN611	SUBARU 1211, 1215, 1217
JN332	FORD 415, 417, 419, 429, 431, 451, 453, 463			JN578	TOYOTA 1279, 1281, 1285, 1287, 1289	JN613	ISUZU 523, 525
				JN580	TOYOTA 1279, 1281, 1285, 1287, 1289	JN616	FORD 461, 467

							
JN619	MERCEDES-BENZ 665, 671, 681, 683, 711, 713, 715, 717, 719, 723 SSANGYONG 1205, 1207	JN658	CITROËN 213, 215, 217, 219, 221, 227, 229, 231, 257, 259, 271, 273, 279, 281 PEUGEOT 925, 927, 929, 931, 935, 937, 941, 947, 949, 953, 975, 977, 985, 987	JN724	FORD 447 NISSAN 789, 805, 819, 821	JN805	FIAT 351, 369, 373, 375, 377, 383, 387, 389, 393, 403, 405, 407 LANCIA 585, 589 ZASTAVA 1555
JN620	FORD 413, 445, 457, 459, 463, 465, 467, 469, 471	JN661	ISUZU 523	JN729	SUBARU 1217	JN806	ALFA ROMEO 9, 11, 43
JN621	MERCEDES-BENZ 667, 687, 689, 697, 701, 713, 715, 717, 719 SSANGYONG 1205, 1207	JN662	FORD 459, 463, 467, 473	JN732	MITSUBISHI 741 OPEL 829 RENAULT 1029, 1031, 1033, 1037, 1039, 1041, 1045, 1047, 1057, 1059, 1065, 1067, 1069, 1073, 1075, 1081, 1089 VAUXHALL 1321 VOLVO 1387, 1389, 1391, 1393, 1411, 1429	JN807	ALFA ROMEO 11, 13, 21, 27, 29, 43 FIAT 331 LANCIA 601
JN622	MERCEDES-BENZ 667, 687, 689, 697, 701, 713, 715, 717, 719 SSANGYONG 1205, 1207	JN663	DAIHATSU 305, 307	JN736	ROVER 1101, 1103, 1105, 1119	JN808	ALFA ROMEO 11, 13, 21, 27, 29, 43 FIAT 331 LANCIA 601
JN623	MERCEDES-BENZ 689, 691, 693, 699, 701, 703, 705, 707	JN664	TOYOTA 1265, 1291	JN739	NISSAN 805, 807, 819	JN809	FIAT 329
JN624	NISSAN 781, 787, 789, 807, 813, 815	JN665	NISSAN 791, 807, 811, 815, 817	JN743	FORD 447 NISSAN 781, 785, 793, 805, 807, 813, 819	JN810	ALFA ROMEO 7, 13, 15
JN625	TOYOTA 1291	JN666	FIAT 317	JN744	ACURA 3 HONDA 483, 487, 489, 491 ROVER 1105, 1111	JN811	ALFA ROMEO 7, 13, 15
JN626	BEDFORD 111 DAEWOO 291, 295 OPEL 829, 831, 833, 835, 837, 847, 849, 851, 853, 855, 857, 861, 863, 865, 885, 887 VAUXHALL 1323, 1325, 1327, 1329, 1335, 1337, 1339, 1345, 1347, 1351, 1353, 1354, 1355, 1363, 1365	JN667	FIAT 327, 361, 363, 365, 367, 369, 381, 383, 393, 403 LANCIA 601, 603	JN752	LEXUS 619 MAZDA 655, 657	JN812	ALFA ROMEO 9, 27, 43
JN628	KIA 575 MAZDA 637, 639, 641, 643	JN667C1	FIAT 361, 363, 365, 367, 369, 381, 403	JN755	HONDA 481 MAZDA 655	JN813	ALFA ROMEO 29 MAZDA 645
JN629	TOYOTA 1261, 1263, 1297	JN669	FIAT 317, 349, 365, 367, 403, 405	JN757	HONDA 495, 497	JN814	ALFA ROMEO 29 MAZDA 645
JN630	TOYOTA 1261, 1263, 1297	JN679	HONDA 483, 487, 491, 493	JN758	CITROËN 215, 279 PEUGEOT 927 ROVER 1103	JN815	FORD 463
JN631	TOYOTA 1265, 1281, 1305	JN681	SUBARU 1213, 1215	JN768	TOYOTA 1259, 1263, 1297	JN816	FORD 421, 423, 425, 435, 437, 449, 455, 457, 465 MAZDA 639
JN632	HONDA 487, 493, 495, 499	JN682	SUZUKI 1223, 1229	JN769	HONDA 497	JN817	FORD 459, 467
JN633	ACURA 3 HONDA 495 ROVER 1117	JN687	NISSAN 813, 821, 823	JN771	TOYOTA 1299	JN819	FIAT 329, 373, 391, 395, 397 LANCIA 587
JN634	BEDFORD 113 ISUZU 521, 529, 531 OPEL 847 VAUXHALL 1341, 1361	JN692	MAZDA 645, 647, 649, 657	JN772	TOYOTA 1299	JN821	FORD 473 LEYLAND / LDV 625
JN635	VOLVO 1385, 1387, 1389, 1393, 1395, 1397, 1399, 1401	JN693	BEDFORD 111, 113 DAEWOO 291, 297 LANCIA 587 OPEL 831, 833, 839, 845, 859, 865, 867, 873, 875, 887, 889, 891 VAUXHALL 1327, 1329, 1331, 1333, 1335, 1337, 1339, 1341, 1343, 1345, 1347, 1349, 1357, 1367	JN774	KIA 575 MAZDA 637, 639, 641, 643, 655	JN822	TOYOTA 1291
JN636	DAIHATSU 309	JN694	OPEL 871, 877, 881	JN775	MAZDA 643, 645	JN829	NISSAN 781, 783, 807, 809, 813, 817, 821
JN640	NISSAN 815	JN697	JEEP 563, 565	JN776	ISUZU 525, 527, 529 OPEL 855, 863 VAUXHALL 1355	JN830	NISSAN 813
JN641	SEAT 1149, 1151, 1157, 1159, 1163, 1175 VW 1465, 1469, 1487, 1517, 1519, 1521, 1523, 1547	JN698	BMW 123, 125, 145	JN777	ISUZU 525, 527, 529 MAZDA 643 OPEL 841, 849, 855, 857, 863, 887 VAUXHALL 1325, 1331, 1339, 1349, 1353, 1355, 1357, 1365, 1367, 1375	JN831	LEXUS 619
JN643	ALFA ROMEO 27 FIAT 329, 331, 373, 389, 391, 393, 395, 397 LANCIA 585, 587, 597	JN699	DAIHATSU 303, 309, 311	JN783	VW 1465	JN832	MAZDA 645, 649, 659
JN644	FIAT 373	JN700	DAIHATSU 303, 309, 311	JN788	NISSAN 749, 753	JN833	MAZDA 645, 649, 659
JN645	FIAT 329, 331, 389, 393 LANCIA 587, 597	JN702	NISSAN 805, 819, 821, 823	JN789	DACIA 287 RENAULT 1025, 1027, 1029, 1037, 1039, 1043, 1055, 1057, 1071, 1081	JN836	ROVER 1107, 1115
JN647	NISSAN 811, 815, 817	JN705	TOYOTA 1253, 1265, 1291	JN792	TOYOTA 1255	JN837	NISSAN 791, 793, 797, 801, 803
JN649	HONDA 497	JN706	TOYOTA 1257, 1269, 1271, 1295	JN798	INFINITI 517 NISSAN 781, 797, 809, 813, 819	JN838	NISSAN 781, 807, 811, 815, 817
JN652	ALFA ROMEO 9	JN707	ISUZU 521, 523, 529 OPEL 847, 859 VAUXHALL 1341, 1359	JN800	MITSUBISHI 741, 743, 759 PROTON 991	JN840	NISSAN 799
JN653	NISSAN 811, 817	JN710	MAZDA 643, 655	JN803	FIAT 327, 363, 381	JN849	VW 1493
JN654	NISSAN 811, 815, 817, 819	JN712	TOYOTA 1249, 1289, 1299, 1307	JN804	FIAT 325	JN851	MERCEDES-BENZ 691, 693, 697, 699, 705
JN655	TOYOTA 1253, 1255, 1259, 1263, 1277, 1295, 1297, 1299	JN713	CHRYSLER 191 MITSUBISHI 745, 747, 751, 765, 767			JN852	MERCEDES-BENZ 691, 693, 697
JN656	SUBARU 1213, 1215, 1217	JN714	MAZDA 651, 655			JN854	SUZUKI 1221
		JN715	HYUNDAI 509			JN857	HONDA 487, 489, 493
		JN717	MITSUBISHI 747, 749, 751			JN865	TOYOTA 1267, 1269, 1283, 1297, 1305, 1307
		JN718	KIA 575, 577 MAZDA 647, 649			JN872	LAND ROVER 613, 615
		JN722	NISSAN 787, 813, 823			JN876	TOYOTA 1257, 1271, 1303
		JN723	NISSAN 787, 813, 821, 823			JN877	MAZDA 647
						JN879	TOYOTA 1303
						JN880	NISSAN 781, 785, 791, 793, 801, 803, 821
						JN886	SUZUKI 1221, 1223, 1225, 1229, 1231, 1233
						JN889	MITSUBISHI 741, 747, 765, 767
						JN897	MITSUBISHI 755, 757, 761 PROTON 991, 993

NUMERICAL PARTS LIST









Numerische Teilenummernliste • Liste des références produits
Lista de referencias

							
JN904	HONDA 499 TOYOTA 1257, 1261, 1267, 1269, 1271, 1303	JN963	LAND ROVER 615 LOTUS 631 MG 727, 729, 731, 733 ROVER 1097, 1099, 1103, 1105, 1107, 1109, 1111, 1117, 1121	JP024	AUDI 51, 53, 55, 61, 67, 73, 85, 93, 97 FIAT 391 SEAT 1143, 1151, 1153, 1155, 1161, 1163, 1167, 1171, 1177, 1179, 1181 SKODA 1189, 1191, 1195, 1197 VW 1449, 1453, 1463, 1467, 1469, 1471, 1473, 1475, 1477, 1483, 1485, 1499, 1501, 1503, 1507, 1509, 1513, 1525, 1527, 1529, 1537, 1547, 1549, 1551	JP069	CITROËN 249, 257 FIAT 345 IVECO 537, 539, 543, 545, 547 PEUGEOT 979
JN911	MERCEDES-BENZ 669, 671, 673, 677, 679, 683, 685, 687, 701, 709, 711, 713, 719, 721, 723	JN964	SEAT 1155, 1167, 1181 VW 1463, 1477, 1509, 1513	JP027	BMW 127	JP070	ALFA ROMEO 19, 25, 31, 41, 45 LANCIA 601
JN914	AUDI 53 SEAT 1153, 1165, 1171, 1179 SKODA 1189 VW 1459, 1477, 1479, 1509, 1511, 1529, 1531, 1543, 1551	JN965	TOYOTA 1281, 1283, 1285, 1287, 1289, 1309	JP032	BMW 127, 171	JP071	ALFA ROMEO 19, 25, 31, 41, 45 LANCIA 601
JN915	AUDI 65 VW 1545	JN966	AUDI 65, 89 VOLVO 1399, 1419, 1423, 1437	JP041	CITROËN 215, 259, 273, 281 NISSAN 799 PEUGEOT 927	JP074	SEAT 1145, 1147, 1149, 1151, 1157, 1159, 1161, 1163, 1169 SKODA 1189, 1191 VW 1455, 1457, 1465, 1469, 1495, 1517, 1519, 1521, 1523, 1527, 1547
JN917	TOYOTA 1259, 1263, 1297	JN969	LANCIA 599 OPEL 873 RENAULT 1083 VAUXHALL 1363	JP043	CITROËN 217, 265, 267, 269, 275, 281, 283 FIAT 339 PEUGEOT 941, 945, 947, 953, 955, 957	JP075	VW 1521
JN918	HONDA 479, 481	JN972	FIAT 319, 323, 353 LANCIA 603	JP044	CITROËN 225, 267, 283 NISSAN 801 PEUGEOT 945, 953, 955, 957	JP077	BMW 127
JN923	OPEL 859, 877 VAUXHALL 1345, 1359	JN973	FIAT 319, 323, 333, 355, 357, 359, 361, 383 LANCIA 585, 589, 593	JP045	CITROËN 247, 261, 269, 271 FIAT 401 PEUGEOT 961, 969, 973	JP078	BMW 129
JN924	OPEL 859, 877 VAUXHALL 1345, 1359	JN994	RENAULT 1075	JP049	CITROËN 241, 251 FIAT 351, 369, 373, 375, 377, 383, 387, 389, 393, 403, 405 LANCIA 585, 589 PEUGEOT 979	JP079	BMW 123, 125, 127, 145, 171
JN925	HONDA 489, 491, 493 ROVER 1105, 1109	JN995	RENAULT 1075, 1077, 1081, 1083	JP063	ALFA ROMEO 15, 17, 23 FIAT 321, 323, 355, 359 LANCIA 593 SAAB 1131	JP083	OPEL 875 VAUXHALL 1367
JN927	JAGUAR 553, 557	JN996	RENAULT 1029, 1031, 1059, 1073, 1087	JP064	ALFA ROMEO 25, 31 FIAT 357 LANCIA 591, 595	JP097	LAND ROVER 615 MG 729, 731 ROVER 1097, 1099, 1109, 1113, 1121
JN928	ALFA ROMEO 21 FIAT 327, 329, 391, 395, 397 LANCIA 587, 589, 591, 597, 599	JN997	RENAULT 1025, 1043, 1087, 1091	JP065	ROVER 1101, 1103, 1105, 1109, 1119	JR087	FIAT 363
JN929	DAEWOO 293 OPEL 833, 835, 837, 839, 849, 855, 857, 863, 869, 887 VAUXHALL 1323, 1325, 1327, 1337, 1351, 1354, 1355, 1359, 1365, 1373	JP003	AUDI 53, 77, 79, 85, 93 FORD 443 SEAT 1141, 1147, 1153, 1155, 1163, 1165, 1167, 1171, 1181 VW 1457, 1459, 1461, 1479, 1483, 1497, 1511, 1527, 1529, 1531, 1533, 1537, 1551	JP066	ALFA ROMEO 11, 13, 21, 29, 35, 39 FORD 461 JEEP 563, 567 LAND ROVER 615 OPEL 859 ROVER 1117, 1121 TOYOTA 1289 VAUXHALL 1359	JR147	TRIUMPH 1313, 1315
JN933	FIAT 325, 327, 357 LANCIA 591	JP006	RENAULT 1035, 1049, 1083	JP067	ALFA ROMEO 11, 13, 21, 29, 35, 39 FORD 461 JEEP 563, 567 LAND ROVER 615 OPEL 859 ROVER 1117, 1121 TOYOTA 1289 VAUXHALL 1359	JR154	FIAT 317, 349, 363, 365, 401
JN934	FIAT 357 LANCIA 593	JP007	ROVER 1117	JP068	ALFA ROMEO 21 CHRYSLER 185, 191 FORD 461 JEEP 563, 567 OPEL 859 ROVER 1117 VAUXHALL 1359	JR264	AUSTIN 105, 107, 109 MG 727 MORRIS 775 ROVER 1117, 1119
JN936	RENAULT 1025, 1037, 1039, 1079, 1091	JP008	OPEL 835, 837, 849, 855, 857, 885, 887 VAUXHALL 1323, 1325, 1329, 1355, 1373	JP069	ALFA ROMEO 11, 13, 21, 29, 35, 39 FORD 461 JEEP 563, 567 LAND ROVER 615 OPEL 859 ROVER 1117, 1121 TOYOTA 1289 VAUXHALL 1359	JR265	FIAT 393 FORD 413, 419
JN937	RENAULT 1033, 1035, 1077, 1083, 1091	JP009	OPEL 835, 837, 849, 855, 857, 885, 887 VAUXHALL 1323, 1325, 1329, 1355, 1373	JP070	CHEVROLET 179, 181 DAEWOO 293, 295, 297 OPEL 841, 843, 845, 859, 875, 883, 889, 891, 897 VAUXHALL 1331, 1333, 1335, 1341, 1351, 1357, 1359, 1367, 1371, 1375, 1377, 1379, 1381	JR349	ALFA ROMEO 7, 13
JN940	ALFA ROMEO 19, 21, 27	JP016	CHEVROLET 179, 181 DAEWOO 293, 295, 297 OPEL 841, 843, 845, 859, 875, 883, 889, 891, 897 VAUXHALL 1331, 1333, 1335, 1341, 1351, 1357, 1359, 1367, 1371, 1375, 1377, 1379, 1381	JP071	OPEL 841 VAUXHALL 1331, 1337	JR529	FIAT 317
JN947	FIAT 331	JP018	OPEL 841 VAUXHALL 1331, 1337	JP072	FIAT 321, 325, 355	JR556	FIAT 347, 349, 401, 405 LANCIA 603
JN948	FIAT 329, 391, 395, 397 LANCIA 585, 587	JP019	FIAT 321, 325, 355	JP073	LAND ROVER 613, 615	JR580	ALFA ROMEO 35, 37 CITROËN 249, 251, 257 FIAT 331, 343, 345, 347 IVECO 535, 537, 539, 541, 543, 545, 547, 549 PEUGEOT 979 RENAULT 1051, 1053, 1091
JN950	FORD 417, 419, 421, 431, 433, 447, 449, 453	JP020	LAND ROVER 613, 615	JP074	MERCEDES-BENZ 673, 675, 687	JR635	DACIA 287 RENAULT 1025, 1035, 1037, 1039, 1061, 1063, 1067, 1071, 1075, 1079, 1081, 1091
JN954	TOYOTA 1249, 1285, 1289, 1291, 1305, 1307	JP022	MERCEDES-BENZ 673, 675, 687	JP075	BMW 127	JR673	FIAT 319, 327, 333, 353, 359, 361, 363, 365, 367, 369, 381, 383, 387, 393, 403 LANCIA 601, 603
JN955	BMW 139, 153, 155 JEEP 565 LAND ROVER 615 OPEL 877 VAUXHALL 1369	JP011	OPEL 841 VAUXHALL 1331, 1337	JP076	BMW 127	JR749	FIAT 329, 389, 391, 397, 401 LANCIA 587, 589, 591, 597, 599
JN956	CITROËN 251 FIAT 343, 345, 347 IVECO 535, 537, 539, 541, 543, 545, 547, 549 OPEL 873 RENAULT 1025, 1053 VAUXHALL 1363	JP012	OPEL 841 VAUXHALL 1331, 1337	JP077	BMW 127	JR5001	ALFA ROMEO 25, 31 FIAT 321, 325, 333, 355, 359, 361, 371, 387 LANCIA 591, 593, 595, 601
		JP013	OPEL 841 VAUXHALL 1331, 1337	JP078	BMW 127	JR5022	BMW 121, 129, 131, 149, 167

							
JR5030	OPEL 829, 833, 849, 851, 855, 869, 883 VAUXHALL 1321, 1323, 1353, 1373	KA611	CITROËN 217, 219, 221, 223, 225, 227, 231, 241, 243, 245, 247, 249, 251, 253, 255, 259, 261, 263, 265, 267, 269, 271, 273, 275, 277, 281, 283, 285 FIAT 339, 379, 397, 399, 401 LADA 579 LANCIA 607 PEUGEOT 933, 935, 939, 941, 943, 945, 947, 951, 953, 955, 957, 959, 961, 967, 969, 971, 973, 977, 979, 981, 983, 987, 989	KD929	CITROËN 249, 257 FIAT 341, 343, 345, 347 IVECO 535, 537, 539, 541, 543, 545, 547, 549 PEUGEOT 979 RENAULT 1053	KJ466	DAIHATSU 303 TOYOTA 1253, 1255, 1257, 1261, 1263, 1265, 1267, 1269, 1277, 1279, 1281, 1287, 1293, 1299, 1303, 1305, 1307, 1309
JR5031	BMW 123, 125, 127, 145, 171	KA625	RENAULT 1029, 1031, 1033, 1037, 1039, 1041, 1045, 1047, 1057, 1059, 1065, 1067, 1069, 1073, 1075, 1081, 1087, 1089 VOLVO 1387, 1389, 1391, 1393, 1411, 1429	KD931	CITROËN 249, 257 FIAT 341, 345, 347 IVECO 537, 539, 541, 543, 545, 547 PEUGEOT 979 RENAULT 1053	KJ468	MAZDA 655
JR5040	MERCEDES-BENZ 675, 677, 689, 691, 693, 695, 699, 703, 705, 707	KA675	NISSAN 781, 783, 791, 793, 813	KD932	CITROËN 249, 257 FIAT 345, 347 IVECO 537, 539, 545, 547 PEUGEOT 979 RENAULT 1053	KJ469	TOYOTA 1261
JR5041	BMW 127	KA725	SUBARU 1213, 1215, 1217	KG393	FIAT 317	KJ502	SUZUKI 1221, 1223, 1225
JR5042	BMW 127	KA738	ALFA ROMEO 21, 29, 31, 41, 43, 45 FIAT 331	KG664	MERCEDES-BENZ 669, 677	KJ570	MITSUBISHI 743, 755, 757, 761 PROTON 991
JR5044	AUDI 91 BMW 131, 133, 135, 137, 141, 147, 149, 151, 157, 161, 171, 173 JEEP 565	KA835	CITROËN 249, 257 PEUGEOT 979	KG5012	MITSUBISHI 741 NISSAN 795, 807, 809 OPEL 873, 895 RENAULT 1031, 1033, 1043, 1045, 1047, 1049, 1051, 1057, 1059, 1085, 1087, 1089, 1091, 1093 VAUXHALL 1361, 1377, 1379 VOLVO 1391, 1393, 1409, 1411, 1427, 1429	KJ577	MITSUBISHI 741, 743, 745, 747, 749, 751, 753, 755, 757, 759, 761, 763, 767, 771, 773 PROTON 991
JR5046	BMW 125, 127, 145, 171	KA845	ALFA ROMEO 15, 17, 23, 25, 31 FIAT 319, 321, 323, 325, 327, 333, 355, 357, 359, 361, 371, 387 LANCIA 591, 593, 595, 601	KG5157	CITROËN 217, 219, 225, 229, 233, 235, 237, 239, 243, 245, 247, 251, 253, 257, 261, 267, 271, 273, 275, 279 FIAT 379, 381, 399, 401 PEUGEOT 929, 935, 937, 939, 943, 945, 947, 949, 959, 961, 963, 969, 971, 973, 975, 979, 981, 983, 989	KJ647	DACIA 287 PEUGEOT 963, 965, 985 RENAULT 1035, 1039, 1049, 1061, 1063, 1065, 1069, 1079, 1081, 1083
JS068	FIAT 319, 327, 355, 371	KA5020	AUDI 51, 53, 57, 59, 95 SEAT 1151, 1161, 1169, 1177, 1179 VW 1457, 1459, 1467, 1469, 1471, 1475, 1487, 1489, 1491, 1501, 1503, 1505, 1507, 1509, 1525, 1533, 1535, 1541	KG5290	PEUGEOT 929, 949 TALBOT 1237, 1239, 1241, 1243	KJ710	FORD 413 MAZDA 639, 641, 645, 647, 649, 651, 655
JS081	ALFA ROMEO 21, 27 FIAT 327, 337, 351, 389, 391, 393, 395, 397, 401 LANCIA 587, 589, 591, 597, 599	KA5021	FORD 429, 445	KG5337	ALFA ROMEO 27, 37, 45 CHEVROLET 179, 181 FIAT 331 OPEL 845, 883, 891, 897 VAUXHALL 1335, 1377, 1379, 1381	KJ722	DAIHATSU 305 TOYOTA 1257, 1263, 1265, 1267, 1269, 1277, 1279, 1281, 1303, 1307
KA289	FORD 413, 419, 427, 445, 459, 463, 465, 467, 469	KA5025	AUDI 67 SEAT 1145, 1147, 1149, 1157, 1159, 1169, 1171, 1175 SKODA 1187, 1189 VW 1449, 1455, 1465, 1467, 1497, 1499, 1517, 1521, 1525, 1547	KH007	IVECO 537	KJ779	DAEWOO 293, 295 SSANGYONG 1205, 1207
KA292	FIAT 341 IVECO 535, 541	KA5032	FIAT 319, 327, 333, 353, 361, 363, 365, 367, 369, 381, 383, 393, 403 LANCIA 601, 603, 605	KH029	FIAT 347, 349, 375, 403, 405	KK5001	FIAT 353, 359, 367, 383
KA293	CITROËN 241, 251 FIAT 373, 375, 377, 387, 393, 403, 405 PEUGEOT 979	KA5035	MERCEDES-BENZ 685, 711, 719, 721	KH066	TOYOTA 1287	KK5002	FIAT 353, 359, 367, 383
KA294	CITROËN 241, 251 FIAT 347, 349, 351, 365, 367, 369, 373, 375, 377, 387, 389, 391, 393, 395, 403, 405 LANCIA 585, 587, 589, 597 PEUGEOT 979 ZASTAVA 1555	KA5036	MERCEDES-BENZ 685, 711, 719, 721	KH202	TOYOTA 1265, 1279	KK5004	FIAT 333, 361, 371
KA295	FIAT 327, 363, 381	KA5038	ALFA ROMEO 9, 31, 33, 39, 41, 43	KJ127	TOYOTA 1263, 1265, 1279	KK5154	HONDA 481, 493 ROVER 1113
KA350	ALFA ROMEO 9, 33, 37, 39, 41, 43	KA5039	ALFA ROMEO 9, 31, 33, 39, 41, 43	KJ156	FIAT 317	KK5155	FIAT 353, 359, 367, 383
KA354	CITROËN 241, 251 FIAT 351, 375, 377, 393, 405 LANCIA 589 PEUGEOT 979	KA5040	FIAT 349, 367, 373, 375, 387, 403, 405	KJ211	MITSUBISHI 741, 743, 745, 747, 749, 751, 753, 755, 759, 761, 763, 765, 767, 771, 773	KK5156	FIAT 387 LANCIA 595
KA499	IVECO 535	KA5041	FIAT 349, 367, 373, 375, 387, 403, 405	KJ452	NISSAN 803	KK5157	FIAT 367 FORD 429, 445
KA500	FIAT 317	KA5042	FIAT 349, 367, 373, 375, 387, 403, 405	KJ454	NISSAN 785, 815, 821	KK5158	FIAT 327 LANCIA 593
KA501	FIAT 317	KA5043	FIAT 349, 367, 373, 375, 387, 403, 405	KJ462	SUBARU 1215	KK5484	BMW 131, 133, 135, 141, 147, 149, 151, 157, 161, 171, 173 JEEP 565
KA525	PEUGEOT 939	KA5044	FIAT 349, 367, 373, 375, 387, 403, 405	KJ464	TOYOTA 1291	KK5495	TOYOTA 1251, 1261, 1267, 1269, 1273, 1295, 1301
KA527	RENAULT 1061	KA5045	FIAT 349, 367, 373, 375, 387, 403, 405			KK5506	LANCIA 591
KA533	RENAULT 1063, 1081	KA5046	FIAT 349, 367, 373, 375, 387, 403, 405			KK5507	LANCIA 591
KA546	FIAT 319, 331, 341, 357 IVECO 535, 541, 547	KA5047	FIAT 349, 367, 373, 375, 387, 403, 405			KK5520	BMW 131, 133, 135, 137, 141, 147, 149, 151, 157, 161, 171, 173
KA547	IVECO 535, 541, 547	KA5048	FIAT 349, 367, 373, 375, 387, 403, 405			KK5522	AUDI 73, 79, 85 MITSUBISHI 751, 763 SEAT 1143, 1175, 1181 SKODA 1195 VW 1483, 1485, 1493, 1515, 1541
KA555	TOYOTA 1265, 1279						
KA556	FIAT 349, 351, 373, 377, 389, 395, 407						
KA606	PEUGEOT 963, 965, 967, 985 SSANGYONG 1205 TALBOT 1243						









NUMERICAL PARTS LIST









Numerische Teilenummernliste • Liste des références produits
Lista de referencias

							
KK5551	AUDI 67	KT600	FIAT 327, 349, 363, 365	LB177	FIAT 327, 333, 359, 361, 363, 365, 367, 369, 381, 383, 387, 393, 403	LK5004	FORD 427, 429, 431, 433, 437, 439, 441, 457
	SEAT 1145, 1147, 1159, 1169, 1171, 1175, 1177	KT639	ALFA ROMEO 21, 27		LANCIA 603		MAZDA 635, 637
	SKODA 1187, 1189		FIAT 327, 329, 331, 349, 351, 373, 375, 377, 389, 391, 393, 395, 401, 407	LB414	FIAT 329, 331, 373		VOLVO 1403, 1407, 1429
	VW 1449, 1455, 1467, 1469, 1497, 1521, 1525	KT738	FORD 419, 427, 445, 459, 463, 465, 467, 469	LB536	LAND ROVER 613	LK5005	FORD 437, 439, 441, 447, 449
KK5598	FIAT 341	KT753	FIAT 317, 349, 363, 365		ROVER 1107, 1109, 1111, 1113, 1115		MAZDA 637
KK5599	FIAT 343, 345, 347	KT754	CITROËN 241, 251	LC280	CITROËN 249, 257		VOLVO 1409, 1429
	IVECO 539, 541, 543, 545		FIAT 351, 369, 375, 377, 389, 393, 405		FIAT 345, 347	LK5006	AUDI 73, 75, 77, 79, 83, 85, 91
	RENAULT 1053, 1091	KT756	CITROËN 241, 251		IVECO 537, 539, 541, 543, 545, 547		FORD 443
KK5643	NISSAN 795, 799, 801		FIAT 375, 377		PEUGEOT 979		SEAT 1141, 1143, 1145, 1147, 1149, 1151, 1155, 1157, 1159, 1161, 1163, 1167, 1169, 1171, 1181
	RENAULT 1027, 1029, 1041, 1043, 1055, 1061, 1083, 1085, 1087	KT758	FIAT 375	LC281	CITROËN 249, 257		SKODA 1189, 1191
KK5646	FIAT 333, 353, 367, 369	KV004	ALFA ROMEO 9, 31, 33, 39, 41		FIAT 343, 345, 347		VW 1455, 1457, 1459, 1461, 1463, 1465, 1469, 1475, 1477, 1479, 1483, 1485, 1493, 1495, 1497, 1501, 1507, 1509, 1511, 1513, 1519, 1521, 1523, 1527, 1529, 1531, 1533, 1537, 1543, 1545, 1547, 1551
	LANCIA 595, 605	KV086	ALFA ROMEO 11, 29, 31, 33, 35, 37, 39, 41, 43		IVECO 535, 537, 539, 541, 543, 545, 547, 549	LK5007	BMW 141, 143, 149, 153, 155, 157, 163, 167, 169, 171
	OPEL 829, 847, 853, 883	KV102	ALFA ROMEO 31, 33, 35, 37, 39, 41, 43	LC282	CITROËN 249, 257		AUDI 67, 71, 73, 79, 83, 85
	SUZUKI 1225, 1229, 1233	KV122	CITROËN 241, 251		FIAT 343, 345, 347	LK5008	SEAT 1143, 1151, 1161, 1171, 1175, 1177, 1181
	Vauxhall 1353, 1373		FIAT 351, 369, 373, 375, 389, 393, 405		IVECO 535, 537, 539, 541, 543, 545, 547, 549		SKODA 1191, 1195
KK5682	BMW 131, 137, 147, 149, 151	KV123	ALFA ROMEO 7, 9, 13	LC292	CITROËN 221, 223, 225		VW 1449, 1463, 1467, 1475, 1485, 1491, 1499, 1501, 1503, 1513, 1515, 1525, 1539
KK5683	DAEWOO 293, 295	KV124	ALFA ROMEO 7, 9, 13		PEUGEOT 933, 935, 939, 941, 953, 955	LK5009	LAND ROVER 613, 615
	MERCEDES-BENZ 665, 671, 675, 677, 681, 683, 689, 691, 693, 695, 699, 701, 703, 705, 707, 711, 713, 715, 717, 719, 721, 723	KV365	FIAT 349, 405	LK5000	KIA 573	LK5011	AUDI 69
	SSANGYONG 1205, 1207	KV412	DAIHATSU 311		LAND ROVER 615		SEAT 1145, 1147, 1157, 1159, 1169, 1171, 1177
KK5684	BMW 127	KV927	CITROËN 249		MG 731		VW 1449, 1455, 1463, 1467, 1469, 1489, 1495, 1497, 1499, 1505, 1517, 1521, 1525, 1539
KL221	FIAT 319, 331, 341, 357		FIAT 343, 345, 347	LK5001	FIAT 319, 321, 353, 359, 367, 369, 383	LK5012	AUDI 69, 71, 73, 79, 85
	IVECO 547	LA055	FIAT 329, 391, 395, 397, 401		LANCIA 603, 605		SEAT 1143, 1165, 1173, 1175, 1181
KL476	ALFA ROMEO 15, 17, 21, 23, 29, 41, 43	LA163	FIAT 347, 349, 367, 405	LK5002	HONDA 479, 491		SKODA 1187, 1193, 1195, 1197
	FIAT 319, 327, 333, 355, 359, 361, 371, 387	LA246	ALFA ROMEO 9, 11, 35, 39		LAND ROVER 611, 613, 615	LK5013	AUDI 69
	LANCIA 593, 595	LA378	CITROËN 241, 251	LK5003	MG 729, 731		SKODA 1191
KL477	ALFA ROMEO 25, 31		FIAT 377, 393, 405		ROVER 1097, 1099, 1109, 1113, 1121		VW 1459, 1461, 1463, 1483, 1485, 1491, 1493, 1497, 1511, 1515, 1537, 1539, 1541, 1543
	FIAT 387	LA564	ROVER 1101, 1103, 1105, 1119		SKODA 1197	LK5014	AUDI 69
	LANCIA 591, 595, 601	LA5204	SEAT 1155	LK5004	AUDI 67, 69, 71, 75, 77, 79, 83, 101		SKODA 1191
KL479	FIAT 319, 353, 359, 367, 383		SKODA 1195		FORD 443	LR902	CITROËN 241, 251
KM5001	LAND ROVER 614	LB025	ALFA ROMEO 27	LK5005	HONDA 485		FIAT 377, 393
	LOTUS 630		FIAT 329, 331, 389, 391, 393, 395, 397, 401		SEAT 1141, 1143, 1145, 1149, 1153, 1155, 1159, 1165, 1167, 1171, 1173, 1177, 1179		PEUGEOT 979
	MG 726, 728, 730, 732	LB161	ROVER 1107, 1109, 1111, 1113, 1115	LK5006	SKODA 1187, 1189, 1191, 1193, 1195, 1197	LR922	FIAT 363, 381
	ROVER 1096, 1098, 1100, 1102, 1104, 1106, 1108, 1110, 1116, 1118, 1120	LB162	LAND ROVER 613		VW 1449, 1451, 1453, 1459, 1461, 1465, 1477, 1479, 1481, 1483, 1485, 1497, 1499, 1501, 1509, 1511, 1513, 1515, 1523, 1529, 1531, 1533, 1535, 1537, 1543		IVECO 535
KS176	FIAT 363	LB175	FIAT 329, 389, 391, 395, 397, 401	LS488	FIAT 349, 367, 405	LR948	IVECO 535
KS696	FORD 445, 459, 461, 467		LANCIA 587, 589, 591, 597, 599	LS492	FIAT 349	LS496	FIAT 347, 349
KS830	FIAT 317, 363, 365			LS649	FIAT 317, 363, 365, 373, 377		
KT005	AUSTIN 105, 107, 109						
	LEYLAND / LDV 627						
	MG 733						
	MORRIS 775						
KT446	FIAT 317, 349, 363, 365						
KT465	ALFA ROMEO 15, 17, 19, 27						
	CITROËN 241, 251						
	FIAT 329, 349, 351, 373, 375, 377, 387, 389, 391, 393, 395, 397, 403, 405, 407						
	IVECO 535						
	LANCIA 587, 599						
	PEUGEOT 979						

NUMERICAL PARTS LIST









Numerische Teilenummernliste • Liste des références produits
Lista de referencias









											
NA5058	FIAT	319, 321, 333, 353, 359, 367, 369, 383	NA5103	BMW	141, 143, 149, 153, 155, 157, 163, 167, 169, 171	NA5124	AUDI	67, 69, 71, 73, 75, 77, 79, 83, 85, 101	NA5136	RENAULT	1049, 1083
	LANCIA	595, 603, 605		LAND ROVER	615, 617		FORD	443		VOLVO	1397, 1399, 1401, 1403, 1405, 1407, 1409, 1411, 1413, 1415, 1417, 1419, 1421, 1423, 1425, 1427, 1429, 1431, 1433, 1435, 1437, 1439, 1441
NA5059	FIAT	325		MG	731		HONDA	485			
NA5060	FIAT	325		ROVER	1101		SEAT	1141, 1143, 1145, 1149, 1151, 1153, 1155, 1159, 1161, 1165, 1167, 1171, 1173, 1175, 1177, 1179, 1181	NA5137	FORD	427, 429, 431, 433, 437, 439, 441, 457
NA5061	FIAT	319, 321, 327, 333, 359, 361, 365, 367, 369, 381, 383, 387	NA5104	BMW	121, 123, 125, 127, 129, 131, 133, 135, 137, 141, 143, 147, 149, 151, 153, 157, 161, 163, 169, 171, 173, 175		SKODA	1187, 1189, 1191, 1193, 1195, 1197		MAZDA	635, 637
	LANCIA	601, 603, 605		LAND ROVER	615, 617		VW	1449, 1453, 1457, 1459, 1461, 1463, 1465, 1467, 1469, 1475, 1477, 1481, 1483, 1485, 1489, 1491, 1493, 1497, 1499, 1501, 1503, 1509, 1511, 1513, 1515, 1523, 1525, 1529, 1531, 1535, 1537, 1539, 1541, 1543, 1545	NA5138	RENAULT	1049, 1083
NA5062	ALFA ROMEO	15, 17, 19, 21, 27		MG	731					VOLVO	1397, 1399, 1401, 1403, 1405, 1407, 1409, 1411, 1413, 1415, 1417, 1419, 1421, 1423, 1425, 1427, 1429, 1431, 1433, 1435, 1437, 1439
	FIAT	321, 323, 327, 329, 331, 337, 349, 351, 361, 371, 373, 375, 377, 387, 389, 391, 395, 397, 407		ROVER	1101				NA5139	CHRYSLER	185, 187, 189
	LANCIA	585, 587, 589, 591, 597, 599	NA5105	BMW	121, 129, 131, 133, 135, 137, 141, 143, 147, 149, 151, 157, 161, 163, 169, 171, 173, 175					MINI	737
NA5063	ALFA ROMEO	7, 9, 13, 15, 31, 33	NA5106	AUDI	67, 69, 71, 73, 75, 77, 79, 83, 85, 87, 101, 443, 445	NA5130	FORD	429, 445	NA5140	CHRYSLER	185, 187, 189
NA5064	ALFA ROMEO	7, 9, 13, 31, 33		FORD	443, 445	NA5131	CHRYSLER	185		MINI	737
	NISSAN	791		HONDA	485		JEEP	567	NA5147	FORD	429, 445
NA5065	ALFA ROMEO	7, 9, 13, 15, 21, 31, 33		SEAT	1141, 1143, 1145, 1147, 1149, 1151, 1153, 1155, 1157, 1159, 1161, 1165, 1167, 1171, 1173, 1175, 1177, 1179, 1181, 1183		LANCIA	601	NA5149	VOLVO	1397, 1399, 1415, 1421, 1431, 1437
	NISSAN	791		SKODA	1187, 1189, 1191, 1193, 1195, 1197		MERCEDES-BENZ	669, 671, 672, 673, 675, 677, 678, 679, 680, 681, 683, 685, 687, 689, 691, 694, 695, 697, 698, 699, 700, 701, 703, 704, 705, 706, 707, 709, 711, 712, 713, 715, 719, 721, 723	NA5157	FORD	437, 439, 441, 447, 449
NA5066	ALFA ROMEO	9, 11, 27		VW	1449, 1451, 1453, 1455, 1457, 1459, 1461, 1463, 1465, 1467, 1469, 1475, 1477, 1481, 1483, 1485, 1489, 1491, 1493, 1497, 1499, 1501, 1503, 1505, 1509, 1511, 1513, 1515, 1517, 1519, 1523, 1525, 1529, 1531, 1535, 1537, 1539, 1541, 1543, 1545, 1547	NA5132	BMW	157, 159, 163, 165, 167, 171		MAZDA	637
NA5068	ALFA ROMEO	9, 11, 13, 19, 21, 25, 27, 29, 31, 39, 41, 43, 45				NA5133	AUDI	51, 53, 55, 57, 59, 61, 63, 65, 67, 73, 75, 77, 79, 81, 83, 85, 87, 89, 91, 93, 95, 97, 99	NA5158	CHRYSLER	185
	LANCIA	601					FORD	443		LANCIA	601
NA5069	ALFA ROMEO	13, 15, 17, 19, 21, 23, 25, 29, 39, 41, 43					JEEP	563		MERCEDES-BENZ	673, 675, 677, 678, 679, 687, 689, 695, 699, 701, 703, 705, 707, 709, 721, 723
	FIAT	319, 321, 323, 325, 327, 355, 357, 371, 385, 387	NA5107	MERCEDES-BENZ	667, 719		SEAT	1141, 1143, 1145, 1147, 1149, 1151, 1153, 1155, 1157, 1159, 1161, 1163, 1165, 1167, 1169, 1171, 1175, 1177, 1179, 1181, 1183	NA5173	JEEP	569
	LANCIA	591, 593, 595	NA5108	CHEVROLET	179, 181		SKODA	1189, 1191	NA5174	OPEL	835, 869, 895
	OPEL	843, 845, 859, 875, 881, 883, 889, 891, 893, 897		OPEL	829, 833, 845, 849, 851, 855, 869, 883, 889, 891, 897		VOLVO	1385, 1395, 1397, 1399, 1401, 1409, 1419, 1423, 1427, 1437		VAUXHALL	1325, 1359, 1379
	SAAB	1133		VAUXHALL	1321, 1323, 1335, 1353, 1371, 1373, 1377, 1379, 1381	NA5109			NA5175	FORD	413, 451
	VAUXHALL	1333, 1337, 1357, 1367, 1371, 1375, 1377, 1381				NA5118	SMART	1201	NA5177	DAEWOO	291, 293, 295, 297
NA5070	ALFA ROMEO	13, 15, 17, 19, 21, 23, 25, 29, 31, 39, 41, 43					SMART	1201		FIAT	327, 363, 381
	FIAT	319, 321, 323, 325, 327, 329, 331, 333, 335, 353, 355, 357, 359, 361, 371, 385, 387	NA5109	MERCEDES-BENZ	667, 669, 719	NA5118	SMART	1201		FORD	443, 459, 471
	LANCIA	585, 591, 593, 595, 601, 603							NA5178	VOLVO	1403, 1405, 1407, 1409, 1411, 1413, 1415, 1417, 1419, 1421, 1423, 1425, 1427, 1429, 1431, 1433, 1435, 1437, 1439, 1441
	OPEL	840, 841, 881, 889, 897									
	SAAB	1131, 1133							NA5179	VOLVO	1405, 1407, 1409, 1411, 1413, 1415, 1417, 1419, 1421, 1423, 1425, 1427, 1429, 1431, 1433, 1435, 1437, 1439, 1441
	VAUXHALL	1333, 1371, 1375, 1379							NA5180	AUDI	67
NA5074	JEEP	567								SEAT	1145, 1147, 1159, 1169, 1171, 1175, 1177
	MERCEDES-BENZ	671, 673, 675, 679, 683, 685, 689, 695, 697, 701, 703, 705, 707, 711, 712, 713, 717, 719, 721								SKODA	1187, 1189, 1197
NA5083	KIA	573								VW	1449, 1455, 1467, 1469, 1497, 1499, 1521, 1525
	LAND ROVER	615									
	MG	731									
	ROVER	1099, 1101, 1117									
NA5089	TOYOTA	1251, 1261, 1267, 1269, 1271, 1273, 1295, 1301									
NA5090	NISSAN	785, 805, 823									
	TOYOTA	1251, 1261, 1267, 1269, 1271, 1273, 1295, 1301									
NA5099	BMW	123, 127, 145, 171									

							
NA5185	AUDI 67	NA5192	CITROËN 217, 219, 221, 223, 225, 227, 229, 231, 235, 237, 239, 241, 243, 245, 247, 249, 251, 253, 255, 257, 259, 261, 263, 265, 267, 269, 271, 273, 275, 277, 279, 281, 283, 285	NA5215	DACIA 287	NA5260	CITROËN 217, 229, 233, 237, 239, 269, 271, 273
	SEAT 1145, 1147, 1149, 1151, 1157, 1159, 1161, 1163, 1169, 1171, 1175, 1177		FIAT 335, 337, 339, 341, 379, 381, 397, 399, 401		NISSAN 783, 795, 799, 801, 811		DAIHATSU 305, 309
	SKODA 1187, 1189, 1191, 1197		FORD 439		RENAULT 1027, 1029, 1041, 1043, 1045, 1053, 1055, 1057, 1061, 1083, 1085, 1087		LANCIA 597
	VW 1449, 1455, 1457, 1465, 1467, 1469, 1495, 1497, 1499, 1517, 1519, 1521, 1523, 1525, 1527, 1547		HONDA 491	NA5223	FIAT 333, 353, 367, 369		MINI 737
NA5187	ALFA ROMEO 15, 17, 19, 27		LADA 579		LANCIA 595, 605		PEUGEOT 927, 929, 937, 939, 947, 961, 971, 975, 987
	FIAT 317, 319, 321, 323, 329, 331, 333, 337, 347, 349, 351, 355, 357, 359, 361, 365, 367, 369, 371, 373, 375, 377, 383, 387, 389, 391, 393, 395, 397, 403, 405, 407		LANCIA 597, 607		OPEL 829, 833, 847, 853, 883		RENAULT 1025, 1031, 1035, 1049, 1051, 1083
	LANCIA 585, 587, 589, 593, 597		LEYLAND / LDV 623, 625		SUZUKI 1225, 1229, 1233		TOYOTA 1253, 1267, 1283, 1297, 1305, 1309, 1311
	TOYOTA 1303		PEUGEOT 933, 935, 937, 939, 941, 943, 945, 947, 949, 951, 953, 955, 957, 959, 961, 963, 967, 969, 971, 973, 975, 977, 979, 981, 983, 987, 989		VAUXHALL 1353, 1373		NA5261
	ZASTAVA 1555		ROVER 1107, 1111		NA5230		NISSAN 795
NA5190	CHEVROLET 179, 181		SUZUKI 1221, 1223, 1227, 1231		FIAT 333, 353, 367, 369		RENAULT 1027, 1043, 1059, 1091, 1093
	DAEWOO 291, 293, 297		TALBOT 1239		LANCIA 595, 605		NA5263
	FORD 413, 415, 417, 419, 427, 429, 431, 443, 445, 451, 453, 457, 459, 461, 463, 465, 467, 469, 471, 473		TOYOTA 1275		OPEL 829, 833, 847, 853, 883		AUDI 91
			VOLVO 1403, 1411, 1429, 1431		SUZUKI 1225, 1229, 1233		BMW 121, 123, 125, 127, 129, 131, 133, 135, 137, 139, 141, 145, 147, 149, 151, 153, 155, 157, 159, 161, 163, 165, 167, 169, 171, 173, 175
NA5191	CITROËN 217, 219, 221, 223, 225, 227, 229, 231, 235, 237, 239, 241, 243, 245, 247, 249, 251, 253, 255, 257, 259, 261, 263, 265, 267, 269, 271, 273, 275, 277, 279, 281, 283, 285	NA5196	FORD 457		HONDA 479, 481, 497, 499		NA5264
	FIAT 335, 337, 339, 341, 379, 381, 397, 399, 401		KIA 575		ROVER 1113		MERCEDES-BENZ 689
	FORD 439		MAZDA 651, 655		NA5243		NA5267
	HONDA 491		NA5197		NISSAN 783, 795, 799, 801		BMW 167
	LADA 579		NA5201		RENAULT 1027, 1029, 1041, 1043, 1045, 1055, 1061, 1083, 1085, 1087, 1093		NA5268
	LANCIA 597, 607		NA5204		NA5244		MERCEDES-BENZ 695, 705, 707
	LEYLAND / LDV 623, 625		CITROËN 215, 217, 219, 229, 231, 233, 235, 237, 239, 243, 245, 247, 251, 253, 257, 259, 261, 265, 267, 269, 271, 273, 275, 277, 279, 281		MITSUBISHI 765, 767		NA5271
	PEUGEOT 933, 935, 937, 939, 941, 943, 945, 947, 949, 953, 957, 959, 961, 963, 969, 971, 972, 973, 975, 979, 981, 983, 985, 987, 989		LADA 579		MITSUBISHI 765		VAUXHALL 1329, 1339, 1347
			PEUGEOT 925, 927, 931, 935, 937, 939, 941, 943, 945, 947, 949, 953, 957, 959, 961, 963, 969, 971, 972, 973, 975, 979, 981, 983, 985, 987, 989		HONDA 481, 497, 499		NA5273
			NA5205		MITSUBISHI 765		VOLVO 1407, 1413, 1415, 1421, 1431, 1433, 1437
			CITROËN 215, 217, 219, 229, 231, 233, 235, 237, 239, 243, 245, 247, 251, 253, 257, 259, 261, 265, 267, 269, 271, 273, 275, 277, 279, 281		NA5245		NA5278
			LADA 579		HONDA 481, 497, 499		AUDI 51, 53, 61, 65, 71, 77, 79, 85
			PEUGEOT 925, 927, 931, 935, 937, 939, 941, 943, 945, 947, 949, 953, 957, 959, 961, 963, 969, 971, 972, 973, 975, 979, 981, 983, 985, 987, 989		MITSUBISHI 765, 767		SEAT 1141, 1147, 1153, 1155, 1165, 1167, 1173, 1177, 1179, 1181
			NA5209		MAZDA 643, 645, 647, 649, 655, 657, 659		SKODA 1187, 1193, 1195
			OPEL 843, 845, 859, 875, 881, 883, 889, 891, 893, 897		NA5246		VW 1451, 1453, 1459, 1469, 1470, 1471, 1475, 1477, 1479, 1481, 1485, 1491, 1493, 1495, 1497, 1501, 1503, 1505, 1507, 1509, 1511, 1513, 1527, 1529, 1531, 1533, 1537, 1541, 1543, 1545, 1547, 1551
			SAAB 1133		MAZDA 643, 645, 647, 649, 655, 657, 659		NB083
			VAUXHALL 1333, 1337, 1357, 1367, 1371, 1375, 1377, 1381		NA5248		AUSTIN 105, 107, 109
					MERCEDES-BENZ 669, 671, 673, 675, 677, 679, 681, 683, 685, 694, 695, 701, 707, 709, 723		MG 727, 733
					NA5255		MORRIS 775
					DACIA 287		ROVER 1119
					NISSAN 783, 795, 799, 801		NB291
					RENAULT 1027, 1029, 1041, 1043, 1045, 1055, 1061, 1083, 1085, 1087, 1093		AUSTIN 105, 107, 109
					NA5256		LAND ROVER 611, 613, 617
					CITROËN 235, 237, 239, 243, 245, 253, 261, 275, 277		LEYLAND / LDV 629
					LANCIA 597, 605		MG 733
					PEUGEOT 937, 947, 957, 959, 961, 963, 969, 971, 973, 975, 981		ROVER 1117, 1121
					NA5257		TRIUMPH 1315
					NISSAN 807		NB384
					OPEL 895		FORD 413
					RENAULT 1025, 1031, 1033, 1043, 1045, 1047, 1049, 1057, 1059, 1085, 1087, 1089, 1091, 1093		MAZDA 639, 641, 653
					NA5258		NB431
					CITROËN 217, 225, 229, 233, 235, 271, 273		BMW 123, 125, 127, 129, 131, 133, 137, 139, 141, 145, 147, 149, 151, 153, 155, 157, 159, 161, 163, 165, 171
					FORD 431, 433, 439, 441		JEEP 565
					MAZDA 635		LAND ROVER 615
					MINI 737		OPEL 877
					PEUGEOT 935, 937, 939, 947, 961, 975, 977		VAUXHALL 1369
					NA5259		NB432
					CITROËN 217, 225, 229, 233, 235, 271, 273		BMW 123, 125, 145
					FORD 431, 433, 439, 441		
					MAZDA 635		
					MINI 737		
					PEUGEOT 935, 937, 939, 947, 961, 975, 977		
					SUZUKI 1225		

NUMERICAL PARTS LIST









Numerische Teilenummernliste • Liste des références produits
Lista de referencias









														
NB452	FORD	471	NB697	BEDFORD	111	NB732	ALFA ROMEO	15, 17, 19, 21, 27	NB806	BEDFORD	111, 113			
NB453	FORD	471		DAEWOO	291, 295		FIAT	321, 323, 327, 329, 331, 337, 349, 351, 361, 371, 373, 375, 377, 387, 389, 391, 395, 397, 407		CHEVROLET	179, 181			
NB469	BEDFORD	113		OPEL	829, 831, 833, 835, 837, 839, 847, 849, 851, 853, 855, 857, 861, 863, 865, 869, 871, 885, 887, 895		LANCIA	585, 587, 589, 591, 597, 599		DAEWOO	291, 293, 295, 297			
	OPEL	859, 869, 871, 877, 879, 881		VAUXHALL	1323, 1325, 1327, 1329, 1335, 1337, 1339, 1345, 1347, 1351, 1353, 1354, 1355, 1359, 1363, 1365, 1373, 1379					LADA	579			
	VAUXHALL	1343, 1345, 1359, 1369					NB734	BEDFORD	111, 113	OPEL	831, 833, 839, 841, 843, 845, 847, 849, 851, 853, 855, 857, 861, 863, 865, 867, 869, 871, 873, 875, 877, 879, 883, 887, 889, 891, 893, 897			
NB564	FORD	413, 415, 427, 445, 459, 461, 463, 467, 473		NB698	BEDFORD	111		OPEL	831, 839, 841, 865, 887, 1327, 1329, 1331, 1337, 1339, 1347		SAAB	1127, 1131, 1135		
NB567	AUDI	65		CHEVROLET	179, 181		NB742	ALFA ROMEO	15, 17, 19, 27	VAUXHALL	1327, 1329, 1331, 1333, 1335, 1337, 1339, 1341, 1343, 1345, 1347, 1349, 1351, 1357, 1359, 1367, 1369, 1371, 1375, 1377, 1379, 1381			
	VW	1501, 1503, 1505, 1507, 1513, 1515, 1521		DAEWOO	291, 293, 295, 297			FIAT	321, 323, 327, 329, 331, 337, 349, 351, 361, 371, 373, 375, 377, 387, 389, 391, 393, 395, 397, 405, 407					
NB572	FORD	415, 427, 429		OPEL	829, 831, 833, 835, 837, 839, 841, 847, 849, 851, 853, 855, 857, 861, 863, 865, 867, 869, 871, 873, 875, 879, 885, 887, 889, 891			LANCIA	585, 587, 589, 591, 597, 599		NB807	DAEWOO	291, 297	
NB575	BEDFORD	111, 113		SAAB	1131		NB772	AUSTIN	105, 109		OPEL	831, 833, 843, 845, 859, 867, 873, 875, 889, 891		
	LADA	579		VAUXHALL	1321, 1323, 1325, 1327, 1329, 1331, 1333, 1335, 1337, 1339, 1341, 1343, 1345, 1347, 1349, 1351, 1355, 1363, 1365			LEYLAND / LDV	623, 625, 627		VAUXHALL	1331, 1333, 1335, 1339, 1341, 1343, 1345, 1349, 1351		
	OPEL	829, 831, 833, 835, 837, 839, 843, 845, 849, 851, 853, 855, 857, 861, 863, 865, 867, 869, 871, 873, 875, 879, 885, 887, 889, 891		NB700	CHEVROLET	179, 181		MG	727, 733, 735					
	VAUXHALL	1321, 1323, 1325, 1327, 1329, 1331, 1333, 1335, 1337, 1339, 1341, 1343, 1345, 1347, 1349, 1351, 1355, 1363, 1365		DAEWOO	291, 293, 295, 297		NB773	ROVER	1105, 1107, 1113, 1115, 1119		NB808	FIAT	317, 327, 349, 363, 381, 389, 393, 401, 405	
NB584	JAGUAR	553, 555, 557		OPEL	831, 833, 841, 843, 845, 859, 863, 865, 867, 869, 873, 875, 879, 883, 887, 889, 891, 897			AUSTIN	105, 109					
NB586	AUSTIN	105, 109		VAUXHALL	1329, 1331, 1333, 1335, 1339, 1341, 1343, 1345, 1347, 1349, 1351, 1357, 1359, 1367, 1371, 1375, 1379, 1381		NB774	HONDA	479, 491		NB814	FIAT	363, 365, 381, 393, 403	
	LEYLAND / LDV	627		NB701	BEDFORD	111		LAND ROVER	613, 615					
	MG	727, 735		OPEL	831, 863, 865, 867, 869, 879			LEYLAND / LDV	623, 625, 627		NB815	FIAT	327, 333, 359, 361, 363, 365, 367, 369, 381, 383, 387, 393, 403	
	MORRIS	775		VAUXHALL	1329, 1331, 1333, 1335, 1339, 1341, 1343, 1345, 1347, 1349, 1351, 1357, 1359, 1367, 1371, 1375, 1379, 1381			ROVER	1097, 1099, 1107, 1109, 1111, 1113, 1115, 1119, 1121					
	ROVER	1105		NB714	SAAB	1125, 1127, 1129, 1131, 1133			MAZDA	639		NB818	FIAT	317, 319, 323, 333, 347, 349, 351, 355, 357, 359, 361, 369, 373, 375, 377, 383, 387, 389, 391, 393, 403, 405
NB596	FORD	415, 417, 419, 421, 423, 425, 429, 431, 433, 435, 443, 451, 453, 455, 457, 459, 463, 465, 467, 473		NB716	AUDI	55, 57, 59, 61, 63, 65, 67, 71, 75, 79, 81, 87, 89, 90, 91, 93, 95, 97, 99			ROVER	1097, 1099, 1105, 1107, 1109, 1111, 1113, 1115, 1119, 1121				
				FORD	443		NB775	ROVER	1097, 1099, 1105, 1107, 1109, 1111, 1113, 1115, 1119, 1121		NB825	ALFA ROMEO	19, 21	
NB628	BEDFORD	113		SEAT	1155, 1165, 1171, 1173, 1179									
	OPEL	859, 869, 871, 875, 877, 879, 881		SKODA	1193, 1195, 1199		NB785	FORD	417, 421, 423, 425, 433, 435, 437, 439, 449, 453, 455, 457, 465, 469, 475					
	VAUXHALL	1343, 1345, 1359, 1369		VOLVO	1385, 1395, 1397, 1399, 1401, 1419, 1423, 1437			MAZDA	639		NB828	LAND ROVER	615	
NB633	FIAT	317, 327, 349, 363, 365, 401		VW	1451, 1453, 1459, 1461, 1463, 1481, 1487, 1493, 1495, 1501, 1513, 1515, 1517, 1533, 1539, 1543, 1545, 1547, 1553									
	SEAT	1175		NB720	JAGUAR	553, 555, 557								
NB645	FORD	415, 417, 419, 429, 431, 443, 451, 453, 459, 463, 465, 467, 471		NB727	FIAT	317, 363								
				NB728	FIAT	317, 363								
NB655	FORD	415, 417, 419, 427, 429, 431, 433, 443, 445, 451, 453, 459, 463, 465, 467, 469		NB730	FIAT	347, 349, 403								
NB684	AUSTIN	105, 107, 109												
	MG	727, 733												
	MORRIS	775												
	ROVER	1119												
NB685	AUSTIN	105												
NB690	BEDFORD	113												
	OPEL	859, 875, 877, 879, 881												
	VAUXHALL	1345, 1359, 1369												
NB691	OPEL	851, 861, 869												
	VAUXHALL	1321, 1363												
NB694	NISSAN	791												
NB696	NISSAN	791												

							
NB848	AUSTIN 107 CARBODIES 177 LAND ROVER 611, 613, 615 LEYLAND / LDV 629	NB974	DAEWOO 293, 295 MERCEDES-BENZ 665, 667, 669, 671, 673, 675, 677, 679, 681, 683, 685, 687, 689, 691, 693, 695, 697, 699, 701, 703, 705, 707, 709, 711, 713, 715, 717, 719, 721, 723 SSANGYONG 1205, 1207 VW 1493	NC065	KIA 573 LAND ROVER 615 LOTUS 631 MERCEDES-BENZ 689, 691, 693, 701, 703, 705, 707 MG 727, 729, 731, 733 OPEL 841, 857, 871, 881, 885, 887, 889, 895 ROVER 1097, 1099, 1101, 1103, 1105, 1107, 1109, 1111, 1117, 1119, 1121 SAAB 1131 VAUXHALL 1331, 1357, 1361, 1373, 1375, 1379	NF562	TALBOT 1237, 1239, 1241, 1243
NB849	AUSTIN 107 CARBODIES 177 LAND ROVER 611, 613, 615, 617 LEYLAND / LDV 629 MG 733 ROVER 1121 TRIUMPH 1315	NB975	MERCEDES-BENZ 665, 681, 687, 689, 693, 697, 699, 701, 715, 717, 719	NC086	FORD 423, 425, 435, 437, 439, 449, 455, 457, 465, 469, 475 MAZDA 639	NF577	CITROËN 213, 245, 255
NB854	FORD 473 LEYLAND / LDV 625	NB978	MERCEDES-BENZ 717, 719	NF009	TALBOT 1237	NF634	PEUGEOT 967 RENAULT 1041, 1063, 1069, 1071, 1075, 1089 TALBOT 1243 VOLVO 1385, 1387
NB855	FORD 473 LEYLAND / LDV 625	NB980	BMW 123, 125, 145	NF032	TALBOT 1237, 1239, 1241, 1243	NF637	BMW 129, 131, 133, 137, 139, 141, 147, 149, 151, 153, 155, 157, 159, 161, 163, 165, 167, 171 CITROËN 241 JEEP 565 LAND ROVER 615 OPEL 877 PEUGEOT 985 VAUXHALL 1369
NB856	FORD 473 LEYLAND / LDV 625	NB984	FORD 421, 423, 425, 435, 437, 449, 455, 457, 465 MAZDA 639	NF036	AUDI 71 CITROËN 213, 245, 255	NF640	PEUGEOT 939
NB866	RENAULT 1075, 1077, 1081, 1083	NB998	KIA 573 LAND ROVER 615 LOTUS 631 MG 727, 729, 731, 733 ROVER 1097, 1099, 1101, 1103, 1105, 1107, 1109, 1111, 1117, 1119, 1121	NF072	TALBOT 1237	NF641	CITROËN 221, 225, 227, 255, 263 PEUGEOT 923, 925, 929, 931 TALBOT 1241
NB884	LADA 579 OPEL 839, 843, 845, 847, 849, 857, 867, 871, 877, 883, 889, 891, 893 SAAB 1127, 1131, 1135 VAUXHALL 1329, 1335, 1337, 1341, 1343, 1351, 1353, 1357, 1361, 1369, 1371, 1377	NC004	OPEL 841, 849 VAUXHALL 1349	NF096	PEUGEOT 985	NF645	CITROËN 233
NB953	VW 1541, 1543	NC006	BEDFORD 111, 113 CHEVROLET 179, 181 CHRYSLER 185, 187, 189 DAEWOO 291, 293, 295, 297 LADA 579 OPEL 829, 831, 833, 835, 837, 839, 841, 843, 845, 847, 849, 851, 853, 855, 857, 859, 861, 863, 865, 867, 869, 871, 873, 875, 877, 879, 881, 883, 885, 887, 889, 891, 893, 895, 897 SAAB 1127, 1131, 1135 VAUXHALL 1323, 1325, 1327, 1329, 1331, 1333, 1335, 1337, 1339, 1341, 1343, 1345, 1347, 1349, 1351, 1353, 1354, 1355, 1357, 1359, 1361, 1363, 1365, 1367, 1369, 1371, 1373, 1375, 1377, 1379, 1381	NF097	FORD 461 LEYLAND / LDV 623, 625 PEUGEOT 963, 965, 967	NF648	CITROËN 239 PEUGEOT 965 RENAULT 1041, 1071
NB958	FORD 413, 417, 419, 421, 431, 433, 439, 441, 445, 447, 449, 453, 469, 475 MAZDA 657	NC007	LAND ROVER 613, 615	NF115	TALBOT 1243	NF663	CITROËN 241
NB959	CITROËN 217, 219, 229, 241, 243, 245, 247, 249, 251, 253, 255, 257, 261, 265, 267, 271, 273, 275, 277, 281, 283 FIAT 335, 337, 339, 379, 397 FORD 413, 417, 419, 421, 431, 433, 439, 441, 445, 447, 449, 453, 469, 475 MAZDA 657 PEUGEOT 935, 937, 941, 943, 945, 955, 957, 959, 969, 971, 977, 979, 981, 987, 989	NC008	LAND ROVER 613, 615	NF185	PEUGEOT 963	NF664	TALBOT 1237
NB971	DAEWOO 293, 295 MERCEDES-BENZ 667, 671, 675, 681, 683, 685, 687, 689, 691, 693, 695, 697, 699, 703, 705, 707 SSANGYONG 1205, 1207	NC009	LAND ROVER 613, 615	NF334	CITROËN 221, 225, 261, 263 PEUGEOT 923, 925, 965 TALBOT 1243	NF677	CITROËN 215
NB973	MERCEDES-BENZ 665, 669, 671, 673, 675, 677, 679, 683, 685, 687, 689, 691, 693, 695, 697, 699, 701, 703, 705, 707, 709, 711, 713, 715, 717, 719, 721, 723 SSANGYONG 1205, 1207 VW 1493	NC015	BMW 123, 125, 133	NF369	FIAT 339, 379 PEUGEOT 983, 985	NF678	CITROËN 221, 225, 227, 255, 263 PEUGEOT 923, 925, 929, 931 TALBOT 1241
		NC044	FORD 423, 425, 435, 437, 449, 455, 457, 465 MAZDA 639	NF387	FORD 445, 467 LEYLAND / LDV 623, 625 PEUGEOT 963, 965, 967, 985 SSANGYONG 1205 TALBOT 1243	NF685	BEDFORD 111 RENAULT 1041, 1069, 1089
		NC048	FORD 427, 429, 431, 433, 437, 439, 441, 457 MAZDA 635 VOLVO 1403, 1407, 1429	NF470	TALBOT 1237	NF687	CITROËN 239 JEEP 565 PEUGEOT 965 RENAULT 1041, 1071, 1079
		NC052	BMW 131, 147	NF505	CITROËN 213, 245, 255	NF692	CITROËN 225, 227 PEUGEOT 929, 931, 949 TALBOT 1237, 1239, 1241, 1243
				NF526	CITROËN 221, 225, 227, 253, 255, 261, 263 PEUGEOT 923, 925 TALBOT 1241	NF694	CITROËN 225, 227 PEUGEOT 929, 931, 949 TALBOT 1237, 1239, 1241, 1243
				NF528	FIAT 379 LADA 579 PEUGEOT 939, 941	NF695	TALBOT 1237
				NF535	DACIA 287 RENAULT 1061, 1063, 1065, 1069, 1081	NF720	CITROËN 239
				NF539	FIAT 379 LADA 579 PEUGEOT 939, 941	NF722	DACIA 287 RENAULT 1041, 1069, 1089 VOLVO 1385, 1387
				NF541	DACIA 287 RENAULT 1041, 1061, 1063, 1069, 1071	NF735	PEUGEOT 923, 925
				NF545	DACIA 287 RENAULT 1041	NF741	CITROËN 231, 241 PEUGEOT 985
				NF554	CITROËN 231, 241	NF746	ROVER 1107, 1111
				NF560	DACIA 287	NF747	CITROËN 213, 245
						NF752	CITROËN 231, 241 PEUGEOT 985
						NF761	CITROËN 271 PEUGEOT 967 RENAULT 1079
						NF764	TALBOT 1243 CITROËN 215

NUMERICAL PARTS LIST









Numerische Teilenummernliste • Liste des références produits
Lista de referencias









								
NF775	RENAULT	1061, 1063, 1065	NF826	CITROËN	213, 215, 219, 221, 223, 225, 227, 231, 241, 251, 263, 265, 267, 269, 279, 281, 283, 285	NF843	CITROËN	239
NF776	CITROËN	231, 241				JEEP	563, 565, 569	
	PEUGEOT	985		FIAT	339, 379, 397, 399	OPEL	829	
NF778	CITROËN	231, 241		PEUGEOT	925, 927, 929, 931, 933, 935, 939, 941, 945, 949, 951, 953, 955, 957, 959, 967, 969	PEUGEOT	965	
	PEUGEOT	985				RENAULT	1029, 1031, 1033, 1035, 1037, 1039, 1041, 1045, 1047, 1051, 1057, 1059, 1065, 1067, 1069, 1071, 1073, 1075, 1077, 1079, 1081, 1083, 1085, 1087, 1089, 1091	
NF780	FORD	459, 461				VAUXHALL	1321	
	LEYLAND / LDV	623, 625		NF833	ALFA ROMEO	35, 37	VOLVO	1387, 1389, 1391, 1393, 1411, 1429
	PEUGEOT	963, 965, 967		FIAT	331, 335, 341, 343			
NF781	JEEP	563, 565		IVECO	541			
	RENAULT	1033, 1035, 1041, 1069, 1071, 1075, 1077, 1079			541			
NF786	RENAULT	1041, 1069		NF834	DACIA	287		
NF791	DACIA	287		RENAULT	1025, 1035, 1037, 1039, 1041, 1061, 1063, 1065, 1067, 1069, 1071, 1075, 1079, 1081, 1089, 1091			
	RENAULT	1025, 1029, 1031, 1035, 1037, 1039, 1041, 1043, 1045, 1057, 1059, 1063, 1065, 1067, 1069, 1071, 1073, 1075, 1079, 1081, 1087, 1091						
	VOLVO	1387, 1389, 1391, 1393, 1411, 1429		NF835	DACIA	287		
NF809	CITROËN	213, 245, 255		PEUGEOT	969			
NF810	CITROËN	253, 261		RENAULT	1025, 1027, 1029, 1035, 1037, 1039, 1041, 1043, 1045, 1053, 1055, 1057, 1061, 1063, 1065, 1067, 1069, 1071, 1075, 1079, 1081, 1083, 1085, 1087, 1089, 1091			
NF812	CHEVROLET	179, 181						
	CITROËN	213, 215, 245, 253, 255, 261		NF836	CITROËN	213, 215, 219, 221, 223, 225, 227, 231, 241, 251, 253, 255, 263, 265, 267, 269, 279, 281, 283, 285		
	DAEWOO	291, 293, 297						
NF814	DACIA	287		FIAT	339, 379, 397, 399			
	RENAULT	1063, 1069		PEUGEOT	923, 925, 927, 929, 931, 933, 935, 939, 941, 945, 949, 951, 953, 955, 957, 959, 967, 969			
NF817	CITROËN	213, 215, 217, 219, 221, 223, 225, 227, 229, 231, 245, 247, 249, 255, 257, 259, 261, 263, 265, 267, 269, 271, 273, 275, 277, 279, 281, 283, 285		TALBOT	1241			
	FIAT	339, 397, 399, 401		NF837	LEYLAND / LDV	625		
	LANCIA	607		NF841	CITROËN	223, 225, 227, 231, 243, 245, 247, 253, 255, 261, 265, 267, 269, 271, 275, 281, 283		
	NISSAN	799						
	PEUGEOT	925, 927, 929, 931, 933, 935, 937, 939, 941, 943, 945, 947, 949, 951, 953, 955, 957, 959, 961, 967, 969, 971, 973, 975, 977, 979, 981, 985, 987		FIAT	339, 379, 397, 401			
	ROVER	1103		HONDA	491			
NF824	CITROËN	243, 245, 247, 249, 253, 255, 257, 261, 267, 269, 271		LADA	579			
	FIAT	339, 379, 401		LEYLAND / LDV	623, 625			
	LANCIA	607		PEUGEOT	933, 935, 941, 943, 945, 951, 953, 955, 957, 959, 961, 969, 971, 973, 983			
	PEUGEOT	957, 967, 969, 973, 977, 979, 981						
NF825	CITROËN	243, 245, 247, 249, 253, 255, 257, 261, 267, 269, 271		ROVER	1107, 1111			
	FIAT	339, 379, 401		SUZUKI	1221, 1227, 1231			
	LANCIA	607		TALBOT	1239			
	PEUGEOT	967, 969, 973, 977, 979, 981						
				NF846	MITSUBISHI	741, 769		
				NISSAN	795, 807, 809			
				OPEL	829, 873, 895			
				RENAULT	1029, 1031, 1033, 1037, 1039, 1041, 1043, 1045, 1047, 1051, 1057, 1059, 1065, 1067, 1069, 1071, 1073, 1075, 1077, 1079, 1081, 1083, 1085, 1087, 1089, 1091			
				VAUXHALL	1321, 1361, 1377			
				VOLVO	1387, 1389, 1391, 1393, 1395, 1397, 1401, 1409, 1411, 1427, 1429			
				NF847	RENAULT	1029, 1047, 1059, 1065, 1089		
				VOLVO	1389, 1391, 1393, 1401			
				NF849	CITROËN	239		
				JEEP	565			
				PEUGEOT	965			
				RENAULT	1029, 1031, 1033, 1035, 1037, 1039, 1041, 1045, 1047, 1051, 1057, 1059, 1065, 1067, 1069, 1071, 1073, 1075, 1077, 1079, 1081, 1083, 1087, 1089, 1091			
				VOLVO	1391, 1393, 1411, 1429			
				NF850	MITSUBISHI	741, 769		
				NISSAN	795, 807, 809			
				OPEL	829, 873, 895			
				RENAULT	1029, 1031, 1033, 1037, 1039, 1041, 1043, 1045, 1047, 1049, 1051, 1057, 1059, 1065, 1067, 1069, 1073, 1075, 1081, 1085, 1087, 1089, 1091, 1093			
				VAUXHALL	1321, 1361, 1377, 1379			
				VOLVO	1387, 1389, 1391, 1393, 1411, 1429			
				NF851	RENAULT	1029, 1073		
				NF853	FIAT	331, 343		
				IVECO	535, 547, 549			
				LANCIA	599			
				RENAULT	1053			
NF856	RENAULT	1025, 1043, 1087, 1091		NF856	RENAULT	1025, 1043, 1087, 1091		
NF857	CITROËN	213, 215, 217, 219, 221, 227, 229, 231, 233, 257, 259, 271, 273, 279, 281		NF857	CITROËN	213, 215, 217, 219, 221, 227, 229, 231, 233, 257, 259, 271, 273, 279, 281		
	NISSAN	799						
	PEUGEOT	925, 927, 929, 931, 935, 937, 939, 941, 947, 949, 953, 975, 977, 985, 987						
	ROVER	1103		NF858	RENAULT	1035, 1049, 1083		
NF858	RENAULT	1035, 1049, 1083		NF859	RENAULT	1049		
NF859	RENAULT	1049		NF860	RENAULT	1025, 1035, 1049, 1051, 1083, 1093		
NF860	RENAULT	1025, 1035, 1049, 1051, 1083, 1093		NF861	RENAULT	1035, 1049, 1083		
NF861	RENAULT	1035, 1049, 1083		NF866	CITROËN	249, 257, 271		
NF866	CITROËN	249, 257, 271		PEUGEOT	969, 979			
NF867	CITROËN	249, 257, 271		NF867	CITROËN	249, 257, 271		
NF869	CITROËN	225, 271		PEUGEOT	969, 979			
	PEUGEOT	953, 955, 969		NF869	CITROËN	225, 271		
NF870	CITROËN	213, 215, 217, 219, 221, 227, 229, 231, 233, 257, 259, 271, 273, 279, 281		PEUGEOT	953, 955, 969			
	NISSAN	799		NF870	CITROËN	213, 215, 217, 219, 221, 227, 229, 231, 233, 257, 259, 271, 273, 279, 281		
	PEUGEOT	925, 927, 929, 931, 935, 937, 939, 941, 947, 949, 953, 975, 977, 985, 987						
	ROVER	1103		NF881	CITROËN	249, 257, 271		
NF881	CITROËN	249, 257, 271		PEUGEOT	969, 979			
NF882	CITROËN	249, 257, 271		NF882	CITROËN	249, 257, 271		
NF883	CITROËN	249, 251, 257		PEUGEOT	969, 979			
	FIAT	335, 343, 345, 347		NF883	CITROËN	249, 251, 257		
	IVECO	535, 537, 539, 541, 543, 545, 547, 549		FIAT	335, 343, 345, 347			
	OPEL	873		IVECO	535, 537, 539, 541, 543, 545, 547, 549			
	PEUGEOT	979						
	RENAULT	1025, 1053, 1091		NF885	CITROËN	249, 251, 257		
	VAUXHALL	1363		FIAT	345, 347			
NF885	CITROËN	249, 251, 257		IVECO	535, 537, 539, 541, 543, 545, 547			
	FIAT	343, 345						
	IVECO	535, 537, 539, 541, 543, 545, 547		OPEL	873			
	OPEL	873		PEUGEOT	979			
	PEUGEOT	979		RENAULT	1025, 1053, 1091			
	RENAULT	1025, 1053, 1091		VAUXHALL	1363			
	VAUXHALL	1363		NF886	FIAT	343, 345		
NF886	FIAT	343, 345		IVECO	535, 537, 539, 541, 543, 547, 549			
NF887	FIAT	319, 323, 333, 355, 357, 359, 361, 369, 377, 383		NF887	FIAT	319, 323, 333, 355, 357, 359, 361, 369, 377, 383		
	LANCIA	585, 589, 593		LANCIA	585, 589, 593			
NF888	ALFA ROMEO	13, 15, 17, 19, 21, 23, 25, 29, 31, 39, 41, 43		NF888	ALFA ROMEO	13, 15, 17, 19, 21, 23, 25, 29, 31, 39, 41, 43		
	FIAT	319, 321, 323, 325, 327, 329, 331, 333, 335, 353, 355, 357, 359, 361, 371, 385, 387		FIAT	319, 321, 323, 325, 327, 329, 331, 333, 335, 353, 355, 357, 359, 361, 371, 385, 387			
	LANCIA	585, 591, 593, 595, 601, 603		LANCIA	585, 591, 593, 595, 601, 603			

							
NJ001	DAIHATSU 303, 305 TOYOTA 1257, 1261, 1265, 1267, 1269, 1271, 1277, 1279, 1287, 1293, 1295, 1303, 1305, 1307, 1309	NJ134	HONDA 479, 481, 497, 499 ROVER 1113	NJ284	INFINITI 517 NISSAN 781, 783, 785, 787, 789, 791, 793, 795, 797, 801, 805, 807, 809, 811, 813, 815, 817, 819, 821	NJ344	DAIHATSU 307, 309 TOYOTA 1249, 1251, 1253, 1255, 1259, 1261, 1263, 1265, 1271, 1273, 1275, 1277, 1279, 1281, 1283, 1285, 1287, 1289, 1293, 1295, 1297, 1299, 1301, 1303, 1305, 1307, 1309
NJ004	FORD 421, 423, 425, 435, 455, 457, 465 NISSAN 785, 815, 821	NJ200	TOYOTA 1249, 1285, 1289, 1291, 1299, 1305, 1307	NJ285	NISSAN 781, 783, 787, 789, 791, 793, 795, 797, 801, 803, 805, 807, 811, 813, 815, 819	NJ346	TOYOTA 1253, 1255, 1259, 1261, 1271, 1273, 1275, 1277, 1293, 1307, 1309
NJ005	HYUNDAI 509 MITSUBISHI 741, 743, 745, 747, 749, 751, 753, 755, 759, 761, 763, 767, 771, 773 PROTON 991	NJ213	NISSAN 787, 813	NJ286	NISSAN 791, 793, 795, 807, 811, 815, 817	NJ347	DAIHATSU 303, 307, 309, 311 TOYOTA 1251, 1253, 1255, 1259, 1261, 1263, 1265, 1271, 1273, 1277, 1279, 1281, 1293, 1295, 1297, 1299, 1301, 1303, 1307, 1309
NJ006	MITSUBISHI 741, 743, 745, 747, 749, 755, 757, 759, 761, 767, 771, 773 PROTON 991, 993	NJ215	TOYOTA 1263, 1285, 1289, 1309	NJ287	NISSAN 789, 791, 793, 795, 797, 801, 803, 805, 807, 811, 815, 817, 821	NJ349	DAIHATSU 305 TOYOTA 1257, 1259, 1261, 1263, 1265, 1267, 1269, 1271, 1277, 1279, 1281, 1283, 1285, 1287, 1289, 1293, 1295, 1303, 1305, 1307, 1309
NJ007	MITSUBISHI 745	NJ222	NISSAN 781, 783, 807, 809, 813, 817, 821	NJ288	NISSAN 791, 793, 795, 807, 811, 815, 817	NJ351	TOYOTA 1263, 1265, 1277, 1279, 1281, 1303
NJ008	MITSUBISHI 745	NJ231	ISUZU 523	NJ306	DAIHATSU 307	NJ353	DAIHATSU 305 TOYOTA 1257, 1259, 1261, 1263, 1265, 1267, 1269, 1271, 1277, 1279, 1281, 1283, 1293, 1295, 1297, 1303, 1305, 1307, 1309
NJ011	BMW 123	NJ239	TOYOTA 1253, 1265, 1283, 1291, 1309	NJ309	HONDA 497, 499	NJ354	TOYOTA 1251, 1253, 1255, 1259, 1261, 1263, 1265, 1277, 1279, 1281, 1283, 1285, 1287, 1289, 1293, 1295, 1299, 1301, 1309
NJ014	ISUZU 521, 523, 525, 527, 529 OPEL 859 SSANGYONG 1205 VAUXHALL 1359	NJ240	TOYOTA 1253, 1265, 1283, 1291, 1309	NJ311	HONDA 479, 495, 497, 499	NJ360	DAIHATSU 303, 307, 309, 311 TOYOTA 1249, 1265, 1269, 1279, 1281, 1283, 1285, 1287, 1289, 1293, 1295, 1299, 1303, 1305, 1307
NJ021	NISSAN 791	NJ242	HYUNDAI 509 MITSUBISHI 741, 743, 745, 747, 749, 751, 753, 755, 757, 759, 761, 763, 765, 767, 771, 773 PROTON 991, 993	NJ312	HONDA 479, 481, 483, 485, 487, 489, 491, 493, 495, 497, 499 ROVER 1103, 1105, 1109	NJ363	NISSAN 799
NJ022	NISSAN 785, 791, 815, 821 SUBARU 1215, 1217	NJ251	HYUNDAI 509 MITSUBISHI 743, 745, 747, 749, 751, 753, 755, 759, 761, 763, 767, 771, 773	NJ313	HONDA 479, 483, 485, 487, 489, 491, 493, 495, 497, 499 ROVER 1103, 1105, 1111	NJ364	NISSAN 799
NJ030	TOYOTA 1263, 1265, 1279, 1281, 1299, 1303, 1305	NJ252	MITSUBISHI 743, 755, 757, 761 PROTON 991, 993	NJ321	BEDFORD 113 ISUZU 523, 525, 527 VAUXHALL 1361	NJ367	MAZDA 639, 651, 653, 657
NJ040	MAZDA 649, 651, 655	NJ254	HONDA 483, 487, 491, 493, 495, 497, 499 TRIUMPH 1313	NJ322	BEDFORD 113 ISUZU 521, 523, 525, 527, 529, 531 OPEL 847, 859 VAUXHALL 1341, 1359, 1361	NJ368	NISSAN 781, 783, 791, 793, 797, 801, 805, 813
NJ042	MAZDA 649, 651, 655 MITSUBISHI 741, 747, 751 TOYOTA 1265, 1279, 1281, 1303	NJ255	MITSUBISHI 741, 743, 745, 747, 749, 751, 753, 755, 759, 761, 763, 767, 771, 773	NJ323	BEDFORD 113 ISUZU 521, 523, 525, 527, 529, 531 OPEL 847 VAUXHALL 1341, 1361	NJ369	NISSAN 785, 789, 793, 803, 805, 821, 823
NJ044	TOYOTA 1257, 1261, 1263, 1265, 1277, 1279, 1281, 1303	NJ265	BEDFORD 113 ISUZU 521, 523, 527, 529 OPEL 847 SSANGYONG 1205 VAUXHALL 1341	NJ324	DAIHATSU 303, 307, 311 KIA 573, 575, 577 MAZDA 643, 645, 647, 649, 651, 653, 655, 657	NJ376	SUBARU 1217
NJ045	NISSAN 781, 785, 787, 789, 793, 795, 797, 801, 803, 805, 813, 819, 821, 823	NJ266	BEDFORD 113 ISUZU 521, 523, 527, 529 OPEL 847 VAUXHALL 1341	NJ325	KIA 573, 575, 577 MAZDA 645, 647, 649, 651, 653, 657	NJ377	CHEVROLET 179, 181 DAEWOO 295 SUZUKI 1223, 1225, 1227, 1229
NJ055	TOYOTA 1291	NJ267	BEDFORD 113 ISUZU 521, 523, 527, 529 OPEL 847, 859 SSANGYONG 1205 VAUXHALL 1341, 1359	NJ330	MAZDA 639, 651, 653, 657	NJ378	SUZUKI 1223, 1225, 1227, 1229
NJ056	NISSAN 781, 785, 787, 789, 793, 795, 797, 801, 803, 805, 813, 819, 821, 823	NJ268	DAIHATSU 303, 305, 307, 311	NJ334	MITSUBISHI 753, 763, 767, 773	NJ381	HONDA 483, 485, 487, 489, 491, 493, 495, 499 ROVER 1103, 1105, 1109
NJ057	MITSUBISHI 763, 767	NJ269	DAIHATSU 303, 305, 307, 311	NJ336	BEDFORD 115 SUZUKI 1221, 1223, 1225, 1227, 1229	NJ384	MAZDA 639
NJ060	ISUZU 521, 523, 525, 527	NJ270	DAIHATSU 303	NJ337	BEDFORD 115 CHEVROLET 179, 181 DAEWOO 295 SUZUKI 1221, 1223, 1225, 1227	NJ386	NISSAN 821
NJ066	BMW 155, 159, 161, 163, 165	NJ274	NISSAN 821	NJ341	SUBARU 1215, 1217	NJ387	NISSAN 821
NJ072	HONDA 483, 497, 499 TRIUMPH 1313	NJ276	DAIHATSU 307, 309, 311	NJ342	SUBARU 1215	NJ407	TOYOTA 1265, 1267, 1277, 1279, 1281, 1303, 1305
NJ073	HONDA 497, 499 TRIUMPH 1313	NJ278	NISSAN 781	NJ343	SUBARU 1215, 1217	NJ419	ALFA ROMEO 7 NISSAN 791, 807
NJ082	NISSAN 791, 799	NJ280	NISSAN 781, 787, 789, 791, 793, 795, 807, 811, 813, 815, 819			NJ437	BMW 155, 159, 161
NJ083	NISSAN 791, 799	NJ283	NISSAN 793, 811, 819				
NJ098	DAIHATSU 307, 309, 311						
NJ099	MAZDA 639, 641, 653						
NJ102	DAIHATSU 303, 311 TOYOTA 1257, 1261, 1265, 1267, 1279, 1281, 1287, 1293, 1303, 1305, 1307						
NJ106	INFINITI 517 NISSAN 781, 797, 809, 813, 819						
NJ107	NISSAN 813						

NUMERICAL PARTS LIST

Numerische Teilenummernliste • Liste des références produits
Lista de referencias

											
NJ446	ISUZU	523, 525	NJ874	MITSUBISHI	745, 747, 751, 765, 767	NK243	SUBARU	1213, 1215	PA349	CITROËN	213, 215, 217, 219, 221, 223, 225, 227, 229, 231, 233, 239, 241, 243, 245, 247, 249, 251, 253, 255, 257, 259, 261, 263, 265, 267, 269, 271, 273, 275, 277, 279, 281, 283
NJ448	KIA	575		VOLVO	1409, 1427	NK251	TOYOTA	1249		DACIA	287
	MAZDA	637, 639, 641, 643, 645, 647, 651, 653, 655, 657	NJ875	ISUZU	523, 525	NP067	ALFA ROMEO	35, 37		FIAT	339, 379, 397, 399, 401
NJ449	ISUZU	523, 525, 527, 529	NJ885	NISSAN	781, 791, 797, 813		CITROËN	249, 251		FORD	445, 459, 461, 467
	MAZDA	643	NJ933	ACURA	3		FIAT	319, 325, 331, 335, 341, 343, 345, 347, 357		JEEP	563, 565, 569
	OPEL	839, 841, 849, 855, 857, 863, 871, 887		HONDA	495		IVECO	535, 537, 539, 541, 543, 545, 547, 549		LADA	579
	VAUXHALL	1325, 1329, 1331, 1337, 1339, 1349, 1353, 1355, 1357, 1361, 1365, 1367, 1375	NJ943	ISUZU	521, 525, 527	NP068	ALFA ROMEO	35, 37		LEYLAND / LDV	623, 625
NJ450	ISUZU	523, 525, 527, 529	NJ951	ALFA ROMEO	21, 29, 45		FIAT	319, 325, 331, 335, 341, 343, 345, 347, 357		OPEL	829
	MAZDA	643		FIAT	331		RENAULT	1025, 1051, 1053, 1091		PEUGEOT	923, 925, 927, 929, 931, 933, 935, 937, 939, 941, 943, 945, 947, 949, 951, 953, 955, 957, 959, 961, 963, 965, 967, 969, 971, 973, 975, 977, 979, 981, 983, 985, 987, 989
NJ454	BEDFORD	113	NJ963	TOYOTA	1253, 1261, 1263, 1265, 1277, 1279, 1281, 1297, 1303, 1309		LANCIA	599, 601		RENAULT	1025, 1027, 1029, 1031, 1033, 1035, 1037, 1039, 1041, 1043, 1045, 1047, 1049, 1051, 1055, 1057, 1059, 1061, 1063, 1065, 1067, 1069, 1071, 1073, 1075, 1077, 1079, 1081, 1083, 1085, 1087, 1089, 1091
	ISUZU	521, 529, 531	NJ978	MAZDA	651, 655	NZ997	LAND ROVER	611		ROVER	1107, 1111
	OPEL	847	NJ982	HONDA	497	OK473	FIAT	329, 391, 395, 397, 401		SSANGYONG	1205
	VAUXHALL	1341, 1361	NJ985	MAZDA	651, 655		LANCIA	587, 589, 591, 597, 599		SUZUKI	1231
NJ552	NISSAN	791, 807	NJ993	TOYOTA	1291	OK627	FIAT	329, 391, 395, 397		TALBOT	1237, 1239, 1241, 1243
NJ553	NISSAN	799	NK005	HONDA	487, 495		LANCIA	587		VAUXHALL	1321
NJ566	TOYOTA	1291	NK015	TOYOTA	1249, 1289, 1299, 1307	PA021	DAIHATSU	311		VOLVO	1387, 1389, 1391, 1393
NJ610	MITSUBISHI	745, 747, 751, 753, 755, 759, 763, 767, 771	NK023	ACURA	3		TOYOTA	1291	PA052	HONDA	483, 497, 499
	NISSAN	791, 807		HONDA	495	PA096	HONDA	481, 499		TRIUMPH	1313
NJ639	NISSAN	791, 807	NK035	MAZDA	651, 655		SUZUKI	1221, 1223, 1225, 1227	PA079	FORD	447
NJ645	TOYOTA	1265, 1281, 1305	NK050	TOYOTA	1249, 1289, 1299, 1307	PA096	SUZUKI	1221, 1223, 1225, 1227		NISSAN	781, 783, 785, 787, 789, 791, 793, 795, 797, 799, 801, 803, 805, 807, 811, 813, 815, 819, 821
NJ646	ISUZU	523	NK055	TOYOTA	1249, 1285, 1289, 1291, 1299, 1305, 1307	PA136	TOYOTA	1249, 1253, 1255, 1259, 1261, 1265, 1271, 1273, 1275, 1277, 1279, 1281, 1283, 1285, 1287, 1289, 1293, 1299, 1303, 1307, 1309		NISSAN	791, 793, 795, 807, 811, 815, 817
NJ650	KIA	575	NK092	MAZDA	643		TOYOTA	1283		TOYOTA	1249, 1281, 1283, 1285, 1287, 1293, 1295, 1295, 1305, 1307
	MAZDA	637, 641, 643, 645, 655, 657	NK102	HONDA	483	PA138	TOYOTA	1279, 1281, 1285, 1289	PA373	HONDA	483, 497, 499
NJ654	TOYOTA	1255, 1259, 1261, 1267, 1275, 1277, 1293, 1305, 1307, 1309	NK103	ISUZU	525	PA139	TOYOTA	1291	PA378	FORD	447
	MITSUBISHI	745, 747, 749, 751, 753, 755, 763, 767, 771, 773		OPEL	839, 841, 849, 855, 857, 863, 871, 887	PA192	TOYOTA	1283, 1291		NISSAN	789, 793, 803, 805, 819, 821
NJ658	NISSAN	795		VAUXHALL	1325, 1329, 1331, 1337, 1339, 1349, 1353, 1355, 1357, 1361, 1365, 1367, 1375	PA203	NISSAN	791, 793, 795, 807, 811, 815, 817	PA385	DAIHATSU	307, 309
NJ675	ACURA	3	NK106	NISSAN	781, 785, 791, 793, 801, 803, 805, 807, 813, 819, 821	PA209	TOYOTA	1283		TOYOTA	1249, 1281, 1283, 1285, 1287, 1293, 1295, 1305, 1307
	HONDA	495		ROVER	1117	PA217	AUDI	71	PA387	DAIHATSU	303, 305, 307, 311
	ROVER	1117	NK125	HONDA	483		CITROËN	213, 215, 233, 241, 245, 253, 255, 261	PA418	ISUZU	521, 523, 527, 529
NJ679	NISSAN	807	NK138	DAIHATSU	305, 307	PA229	PEUGEOT	985		OPEL	847, 859
NJ688	NISSAN	787, 791	NK143	HYUNDAI	511, 513		FORD	445, 459, 461		VAUXHALL	1341, 1359
NJ689	NISSAN	787, 815		KIA	575	PA260	LEYLAND / LDV	623, 625	PA424	HONDA	497, 499
NJ692	NISSAN	787		MITSUBISHI	741, 743, 745, 747, 749, 753, 759, 761, 763, 767, 769, 771		PEUGEOT	963, 965, 967, 985	PA425	PROTON	991
NJ693	TOYOTA	1251, 1253, 1259, 1263, 1295, 1297, 1299, 1301	NK157	MAZDA	637, 639, 641, 655		FORD	445, 459, 461		TOYOTA	1249, 1251, 1253, 1255, 1257, 1259, 1261, 1263, 1265, 1267, 1269, 1271, 1277, 1279, 1281, 1285, 1289, 1291, 1293, 1295, 1297, 1299, 1301, 1303, 1305, 1307, 1309
NJ703	HONDA	483	NK158	KIA	573, 575, 577	PA286	TRIUMPH	1313			
NJ706	TOYOTA	1253, 1255, 1259, 1261, 1271, 1273, 1275, 1277, 1293, 1307, 1309		MAZDA	641, 643, 645, 651, 653, 655, 657	PA288	HONDA	479, 483			
NJ719	TOYOTA	1269, 1293	NK159	ROVER	1105, 1111	PA305	BEDFORD	115	PA426	MAZDA	639, 651, 653, 657
NJ765	NISSAN	781, 783, 791, 793, 797, 801, 803, 807, 809, 811, 813, 815, 817, 819	NK180	TOYOTA	1249, 1289, 1299, 1307		SUZUKI	1221, 1223, 1225, 1227, 1229			
NJ829	FORD	447	NK205	MAZDA	645, 647, 655, 657	PA310	TOYOTA	1253, 1265, 1291			
	NISSAN	789, 805, 819, 821	NK209	DAIHATSU	303, 307, 309, 311	PA313	HONDA	479, 497, 499			
NJ831	FORD	447	NK212	NISSAN	807						
	NISSAN	789, 805, 819, 821	NK214	TOYOTA	1251, 1253, 1259, 1295						
NJ838	NISSAN	787		VW	1539						
NJ843	NISSAN	807	NK215	TOYOTA	1251, 1259, 1261, 1275, 1299						
NJ844	NISSAN	787	NK216	TOYOTA	1293						
NJ846	SUBARU	1213, 1215, 1217									
NJ873	MITSUBISHI	745, 747, 751, 765, 767									

							
PA459	AUDI 51, 53, 59, 61, 85, 95 SEAT 1151, 1153, 1161, 1163, 1169, 1177, 1179 VW 1457, 1459, 1463, 1467, 1471, 1473, 1475, 1477, 1489, 1491, 1501, 1503, 1507, 1509, 1525, 1533, 1535, 1541, 1549	PA883	KIA 575 MAZDA 637, 641, 643, 645, 649, 651, 655, 657	PB341	TOYOTA 1269, 1297, 1307		
PA468	MITSUBISHI 741, 747, 751	PA884	NISSAN 803	PB344	TOYOTA 1249, 1289, 1299, 1307		
PA528	ACURA 3 HONDA 479, 483, 485, 487, 493, 495, 497, 499 ROVER 1103, 1117	PA889	DAIHATSU 305, 307	PB353	HONDA 481 MAZDA 641 ROVER 1113		
PA529	HONDA 479, 497, 499	PA928	SUZUKI 1223, 1227, 1229	PB354	HONDA 481 MAZDA 641 ROVER 1113		
PA531	HONDA 479, 483, 485, 487, 493, 495, 497, 499 ROVER 1103	PA933	BEDFORD 113 FORD 447 ISUZU 521, 523, 525, 527, 529, 531 NISSAN 781, 783, 785, 787, 789, 791, 793, 795, 797, 801, 803, 805, 807, 813, 815, 819, 821, 823 OPEL 847 VAUXHALL 1341, 1361	PB355	ACURA 3 HONDA 479, 481, 483, 487, 489, 491, 493, 495, 497, 499 ROVER 1105, 1111		
PA543	OPEL 859, 875, 877, 879, 881 VAUXHALL 1345, 1359	PA952	DAIHATSU 303, 307, 309, 311	PB356	ACURA 3 HONDA 479, 481, 483, 487, 489, 491, 493, 495, 497, 499 ROVER 1105, 1111		
PA565	DAEWOO 291, 293, 295, 297 LADA 579 OPEL 831, 833, 835, 837, 839, 843, 845, 847, 849, 851, 852, 853, 855, 857, 859, 861, 863, 865, 867, 869, 873, 875, 877, 881, 885, 887, 889, 891 VAUXHALL 1323, 1325, 1327, 1329, 1331, 1333, 1335, 1337, 1339, 1341, 1343, 1345, 1347, 1349, 1351, 1353, 1354, 1355, 1357, 1363, 1365, 1367, 1369, 1373	PA956	KIA 575, 577 MAZDA 637, 639, 641, 643, 645, 647, 649, 651, 655, 657	PB681	NISSAN 781, 783, 807, 811, 815, 817		
PA567	TOYOTA 1265, 1267, 1269, 1277, 1279, 1281, 1283, 1303, 1305, 1307	PA968	HYUNDAI 509 MITSUBISHI 741, 743, 747, 749, 751, 757, 759, 761, 765, 767 PROTON 991, 993	PB852	CITROËN 213, 215, 217, 219, 221, 227, 229, 231, 233, 237, 239, 249, 257, 259, 269, 271, 273, 279, 281 JEEP 563, 565, 569 PEUGEOT 925, 927, 929, 931, 935, 937, 939, 941, 947, 949, 953, 961, 963, 971, 975, 977, 979, 985, 987 RENAULT 1029, 1031, 1033, 1035, 1041, 1051, 1059, 1071, 1073, 1075, 1077, 1079, 1081, 1083, 1087, 1089, 1091		
PA606	MAZDA 653, 657	PA969	HONDA 481, 483, 485, 487, 489, 491, 493	PB853	RENAULT 1083		
PA630	HONDA 483, 485, 493, 495, 497, 499	PA970	HONDA 481, 483, 485, 487, 489, 491, 493	PB907	CITROËN 215, 217, 219, 221, 223, 229, 235, 237, 239, 241, 243, 245, 247, 249, 251, 253, 255, 257, 259, 261, 265, 267, 269, 271, 273, 275, 277, 279, 281, 283, 285 FIAT 339, 379, 381, 397, 399, 401 PEUGEOT 927, 933, 935, 937, 939, 941, 943, 945, 947, 949, 951, 953, 955, 957, 959, 961, 963, 967, 969, 971, 973, 975, 977, 979, 981, 983, 987, 989 ROVER 1103		
PA655	SUBARU 1213, 1215, 1217	PA971	DAIHATSU 303				
PA656	SUBARU 1213, 1215, 1217	PA5013	RENAULT 1027, 1031, 1033, 1043, 1045, 1047, 1049, 1053, 1057, 1059, 1061, 1083, 1085, 1087, 1091, 1093 VAUXHALL 1379				
PA658	ISUZU 523, 525, 527, 529 MAZDA 643 OPEL 841, 849, 855, 857, 863, 887 VAUXHALL 1325, 1331, 1339, 1349, 1353, 1355, 1357, 1365, 1367, 1375	PA5016	BMW 141, 143, 153, 155, 157, 163, 169, 171 LAND ROVER 617 OPEL 877 ROVER 1101 VAUXHALL 1369				
PA659	KIA 573, 577 MAZDA 647, 651, 653, 657	PA5019	TOYOTA 1251, 1261, 1267, 1269, 1271, 1273, 1295, 1301				
PA815	MERCEDES-BENZ 665, 681, 687, 689, 697, 703, 705, 715, 717, 719	PA5020	NISSAN 785, 805, 823 TOYOTA 1251, 1261, 1267, 1269, 1271, 1273, 1295, 1301				
PA850	CITROËN 213, 215, 217, 219, 221, 227, 229, 231, 257, 259, 271, 279, 281 PEUGEOT 925, 927, 929, 931, 935, 941, 947, 949, 953, 975, 985, 987	PA5025	OPEL 829, 849, 851, 857, 871, 881, 885, 887, 889, 895 SAAB 1131 VAUXHALL 1321, 1353				
PA858	CITROËN 213, 215, 219, 221, 227, 257, 259, 279, 281 PEUGEOT 925, 927, 929, 931, 941, 949, 953	PA5033	FORD 429, 445				
PA874	NISSAN 783, 811, 813, 815, 817, 819	PB071	NISSAN 811, 815, 817				
		PB156	HONDA 489, 491, 493, 495, 497 ROVER 1105, 1109				
		PB256	MERCEDES-BENZ 689, 703, 705				
		PB259	CITROËN 215, 259, 273, 279, 281 PEUGEOT 927				
		PB281	LEXUS 619 TOYOTA 1255, 1259, 1261, 1263, 1297, 1299				
		PB313	MAZDA 645, 647, 649, 659				
		PB314	MAZDA 645, 647, 649, 659				
		PB340	TOYOTA 1267, 1305, 1307				

INTERCHANGE OE → PAYEN

Vergleichsliste OE → Payen • Références croisées 1ère Monte → Payen
Intercambio entre equipo original y Payen

OE reference	▲ Payen	OE reference	▲ Payen	OE reference	▲ Payen	OE reference	▲ Payen	OE reference	▲ Payen
00A103085A	NB973	1N2G6051A2D	AD5020	3C1Q6051AA	AA5940	5S43-9448-AC	JE5037	8AB110271	GJ432
00A198012	DZ160	1S4G6K321AA	LK5004	3C1Q6051BA	AA5950	5S7Q6051AA	AA5970	8AB110271HS	DJ432
0B3C7-10-602B	NK158	1S4Q6051GA	AB5300	03C253039A	JD5814	5S7Q6051CA	AA5990	8AB210235	DP601
0B6S710235C	JM5296	1S4Q6051HA	AB5310	03D 103 383 G	AG8840	6 165 502	NB848	8AB310235	DP571
OK05410270	CG5460	1S4Q6051JA	AB5320	03D 129 717 A	JD5807	6 52 600	JJ536	8AB310235A	DP571
OK054-10-270	CG5460	1S4Q6051JB	AB5320	03D 129 717 B	JD5808	6 535 949	HR631	8AB310271	GP540
OK05410271	AG5130	1S4Q6051KA	AB5330	03D 253 039 B	JD5819	6 763 409	JA769	8AB310271HS	DP540
OK24710271B	AG8200	1S4Q6051LA	AB5340	03D103383G	AG8840	06A 103 338 F	AY970	8AB410235	DV110
OK2A310271	AG7840	1S4Q6051MA	AB5350	03D253039B	JD5819	06A103171A	LK5003	8AB510271	GJ432
OK2AC10270	FG7840	1S6G6K260AA	JM5155	03E 129 717 B	JD5811	06A103338F	AY970	8AB610235	DS950
OK2NC10271	AG8260	1S7E6051DC	AC5780	03E 253 039	JD5816	06A103383AH	AY970	8AB610271	GP600
OK30C-10-135A	HBS387	1S7E6083DC	AC5790	03E103383F	AF5990	06A103383AN	AB5370	8AB710271	GP600
OK30C10235A	JM5295	1S7G6013AA	DW642	03E129717B	JD5811	06A103383F	AY970	8AB710271A	GP600
OK30C10270	FG7830	1S7G6051AF	AD5220	03E253039	JD5816	06A103383L	AB5370	8ABA10271	GJ432
OK30C10271A	AG7830	1S7G6051AG	AC5940	03G 103 383 AA	AG8970	06A103384C	HBS246	8ABD10271	GP570
OK30E10135A	HBS436	1S7G6051BE	AC5940	03G 103 383 AC	AG8960	06A103385A	HBS268	8ABD10271HS	DP570
OK30E10235	JM5320	1S7G6051BF	AC5940	03G 103 483 B	JM7029	06A103483C	JM5103	8ABF10271	GR961
OK30E10270	FG8250	1S7G6051BG	AC5940	03G 129 717 B	JD5806	06A103609C	JH5117	8ABF10271HS	DR961
OK30E110271A	AG8250	1S7G6584AE	JM5158	03G 129 717 C	JD5805	06A129717	JD5291	8ABL10271HS	DR960
OK30F10135	HBS436	1S7G6700AC	NA5157	03G103383	AG8960	06A129717D	LA5204	8ABN10271	GS070
OK55110235	JM5310	1S7G6A321AA	LK5005	03G103383A	AG8800	06A129717F	JD5292	8ABN10271HS	DS070
OK55110270	FG8140	1S7G6A517BG	HR5063	03G103383AA	AG8970	06A133398D	JD607	8ABS10271	GP602
OK55110271A	AG8140	1S7G6K260AA	JM5153	03G103383AB	AG8800	06A133398F	JD5340	8ABS10271HS	DP602
OK56A10271B	AG9910	1S7G9441AE	JD5299	03G103383J	AG9630	06A198011	EC080	8ABT10271A	GP601
OK65A10236C	JM5196	1W936051AA	AC5510	03G103384	HBS364	06A198011A	EY841	8ABV10271	GP571
OK65A10270A	FE5470	1W936051AC	AC5510	03G103483	JM7031	06A198012	CY980	8ABV10271A	GP571
OK65A10271B	AE5470	1W936083AC	AC5500	03G103483B	JM7029	06A198012A	CY971	8AG310235	DR732
OK65A13461B	JD5327	2A24	JM302	03G129717B	JD5806	06A253039L	JD5293	8AG310235A	DR732
OK90011312	NA5197	2A3539	NB684	03G129717C	JD5805	06B 103 383 AF	AG8810	8AG310271	GR732
OK95510135	HBS455	2A689	AF070	03G253039	JD5815	06B 253 039 E	JD5813	8AG410235A	DR733
OK9AB10270B	FG8200	2A719	JA439	3M5Q 6051 AA	AD5130	06B103171B	LK5008	8AG510235B	DV410
OK9BV10135	HBS423	2A805	JM302	3M5Q 6051 BA	AD5140	06B103383AE	AC5220	8AG510271	GR730
OVS0110602	NA5196	2A935	AF070	3M5Q 6051 CA	AD5150	06B103383AF	AG8810	8AG510271HS	DR730
1 004 928	NA5001	2A939	NA473	3M5Q 6051 DA	AD5160	06B103383H	AC5220	8AG610235	DR380
1 005 254	BX800	2A971	AF070	3M5Q 6051 EA	AD5170	06B103383R	AG8810	8AG610271	GR850
1 005 261	BX820	2F3121	NB628	3M5Q 6L004AA	HA5030	06B103383T	AC5220	8AG610271A	GR850
1 005 262	JP003	2F3122	NB628	3M5Q 6L004BA	HA5031	06B103483H	JM7030	8AG610271B	GR850
1 005 303	NA5133	2M5Q6L270AA	NB785	3M5Q6700BC	NA5191	06B103483L	JM5205	8AG610271HS	DR850
1 005 891	JC152	2N1324	JN234	3M5Q6L004AA	HA5030	06B129717A	JD5341	8AG710271A	GN622
1 033 121	JJ609	2R8E6710AA	JH5065	3M5Q6L004BA	HA5031	06B253039E	JD5813	8AG710271AHS	DN622
1 064 459	JE5025	2R8E6710BA	JH5065	3S4G6051BA	AG8310	06D103383L	AG9600	8AG810271B	GR736
1 119 182	NA5157	2S6G6A321AA	NA5130	3S7Q6051BA	AA5980	06D103383M	AG9600	8AG810271C	GR736
1 148 115	JD5829	2S6G6D321AA	NA5147	3S7Q6700AA	NA5031	06D103385	HBS363	8AG810271CHS	DR736
1 254 375	HA5030	2S6Q6700AA	NA5259	3S7Q6710AA	HC5004	06D103483D	JM7048	8AGC10271	GR850
1 254 376	HA5031	2S6Q6L270AA	NA5258	3S7Q6710BA	HC5004	06D129717D	JD5873	8AGC10271A	GR850
1 308 383	AC5800	2S6U9441AA	JD5227	4F1Z6065AB	HBS392	6E0253115	JE5036	8AGC10271B	GR850
1 576 425	KS696	2S7Q9448BA	JA5085	4F1Z6065AB (16x)	HBS392	6M5G6051AA	AG8320	8AK310271	FG8150
001 997 74 47	PA815	3.681E051	AG900	4H236051AC	AD5600	6S43-9448-AA	JE5037	8AK3-10-271	FG8150
1.0512013	AN300	3.681E053	AG910	4H236083AC	AD5610	6S43-9448-AB	JE5037	8AL110235	DS280
1.16011	BC370	3.681E054	AG910	5-87810-261-0	DK502	8-94317375-4	CD5400	8AL110271	GS280
1.16013	BC370	03C 103 383 D	AG8850	5-87810-979-0	CG5500	8-94360527-0	JM7040	8AN110235	DS940
1.1633011	AN300	03C 129 717 C	JD5809	5C1Q6051AA	AA5940	8-94362-742	BW180	8AN110271	GS940
1G2324	JM315	03C 253 039 A	JD5814	5C1Q6051BA	AA5950	8-97019361-0	AG5080	8AN210235	CG5370
1G2417	JA282	03C103383C	AG8850	5C1Q6051CA	AA5960	8-97136259-2	AB5781	8AN2-10-235	CG5370
1H0253115	JE5075	03C103383D	AG8850	5H2E6700AA	NA5190	8-97148520-2	AB5780	8AN210271	CG5370
1J0253115D	JF211	03C129717C	JD5809	5S439448AB	JE5037	8AB110235	DP600	8AN210271A	CG5370

OE reference	▲ Payen	OE reference	▲ Payen	OE reference	▲ Payen	OE reference	▲ Payen	OE reference	▲ Payen
8AN210271B	CG5370	8G2559	CF463	021 253 050	JD5109	061A1PC7030	DM920	70HM6051GA	AH860
8AN410271	GS941	8G2560	CF463	22A1283	NB684	061A1PC7040	DM920	70HM6571A3B	HR655
8AN4-10-271	GS941	8G2561	EF462	025 129 717 C	JD237	061A1PC7660	DM920	70HM6701A3A	NA793
8AN610271A	GS953	8G2697	NB684	026 103 085 A	NA5001	061A1PD2000	DL361	70HM6701AA	NA793
8ASX10235	CA5030	8G731	HCO48	026 106 675	HR805	061A1PD3000	DM921	70HM8507AA	KA289
8ASX10271B	FA5130	8G756	HCO63	026 109 675	HR569	061A1PE0000	GM991	70HM8507AB	KA289
8AU110235	DR731	8HBW10271	FG7850	26E026	AF880	061A1PE0670	GM990	70TM6051GA	BL090
8AU110235A	DR731	8LB910271	FG8170	26E082	CF880	061A1PE1720	DM993	70TM6083GA	BL080
8AU110235B	DR731	8LG310271	FG8190	26S004	JA475	061A1PE3000	DM995	70TM6734AA	KG664
8AU110271	GL321	9S9V360005	NJ337	027 109 675	HR816	061A1PE3010	DM995	71BB1190A1B	NA585
8AU110271A	GL321	11 12 1 740 065 (14x)	HBS413	028 103 609 B	JJ140	061A1PE3020	DM995	71BB1190A3B	NA585
8AU110271B	GL321	11 12 7 805 927	JM7034	028 103 609 D	JJ140	061A1PE7000	DM992	71BB1190AB	NA585
8AU110271C	GL321	11 42 2 249 532	NA5105	028 103 717 D	JD170	061A1PE7010	DM992	71BB1190E1B	NA585
8AU310271	GN621	11 61 1 247 478	JD611	030 103 384D	HBS362	061A1PE7661	DM992	71HM6013AA	HC285
8AU310271A	GN621	11 61 1 717 259	JD493	032 103 609 D	JJ183	061A1PE7662	DM992	71HM6013BA	HC285
8AU310271AHS	DN621	11 61 1 721 763	JD490	034 103 383 D	AY960	061A1PE8000	DN240	71HM6014AA	CH851
8AU310271B	GN621	11 61 1 726 012	JD239	035 121 171 C	PA459	061A1PG7660	DP630	71HM6014DA	CH851
8AU510271	GR731	11 61 1 726 016	JD315	035 121 717 C	PA459	061A1PH3000	DP740	71HM6014EA	CH861
8AU510271A	GR731	11 61 1 734 684	JD490	036 103 383 AL	AB5701	061A1PH3660	DP740	71HM6014FA	CH851
8AU510271B	GR731	11 61 1 739 545	JD608	045 103 483 C	JM7032	061A1PH4000	DN450	71HM6014GA	CH851
8AU810271	GR734	11 61 1 740 069	JD492	047 129 717 E	JD5812	061A1PH4600	DN450	71HM6584GA	JM510
8AU810271HS	DR734	11 62 1 744 252	JD497	048 198 383 D	BY750	061A1PJ0000	DN450	71HM6584KA	JM510
8AZ610271A	GN621	11 62 7 806 008	JD5829	48G220	CD950	061A1PJ0A00	DN451	71HM9441AB	JA769
8CB110271	GV110	11G276	JM315	48G243	CD950	061A1PJ1000	DP630	71HM9448AA	JA768
8CB210271	GS953	11G300	JM315	48G332	CD950	061A1PK2660	DS111	71HM9448BA	JA770
8CB210271N	GS953	12A1175	KT005	48G342	EE781	061A1PL2000	DR650	72GE76571A	NA162
8CB310271	GS950	12A14	JM302	48G398	EG411	061A1PL2660	DR650	72GE76572A	NA162
8CB610235	DV431	12A190	AF070	48G498	CE780	061A1PL2661	DR650	72GE7657AA	NA162
8CB610271	GV431	12A192	JA439	48G534	EG411	061A1PM3000	DR540	72TM6571A1A	HR633
8CBF10271	GS953	12G2230	AF460	48G751	CE780	061A1PM4000	DR541	73TM6584AA	JM875
8CBR10235	DE545	12G2625	JR264	48G90	CD950	061A1PM5A03	DR540	76VB1175BA	NB792
8CBR10271	DE545	12G293	AF070	053 198 012 E	DT813	061A1PM6000	DR541	77 01 052 721	AG9790
8CBZ10235	CG5380	12G300	JA439	56 07 430	AY410	061A1PM7G00	DS881	77 01 052 722	AG9800
8CBZ-10-235	CG5380	12H1506	AE780	56 07 431	AY420	061A1PT3000	DS700	77BM6051A1A	BC240
8CBZ10235A	CG5380	12H1819	AE780	56 07 451	HBS419	061B1PA1000	EC633	77BM6051A2A	BC240
8CG610271	CG5390	12H1952	JH396	56 07 819	AG9800	061B1PA1010	EC633	77BM6051A3A	BC240
8CG6-10-271	CG5390	12H301	AE780	56 07 824	AG9790	061B1PE0000	EM992	77BM6561CA	JN105
8CG610271A	CG5390	12H37	JM315	058 129 717 C	JD5820	061B1PE0010	EM992	77BM6584BA	JN105
8CG610271B	CG5390	12H433	AD950	059 103 383 CM	AG8880	061B1PG7000	ES880	77BM6584CA	JN105
8CGB10271	CG8191	12H4749	AK660	059 103 383 CN	AG8860	061B1PR4A00	ES890	77BM6700AB	NB564
8DSX10271	FA5130	12H4965	BD970	059 103 383 CP	AG8890	061B1PT3000	GS700	77BM9148EA	JB799
8E89736	AC5720	12H4969	BD970	059 103 383 CQ	AG8900	068 103 085 E	NA5001	77BM9441DA	JB862
8EBN10235	CA5030	12H751	AK660	059 103 383 CR	AG8870	68AB1190A1A	NA579	77BM9448EA	JB799
8FG6-10-271	GV380	13H106	NA448	059 103 383 CS	AG8910	68AB1190A3B	NA579	77BM9448EB	JB799
8FGB10271	CG8191	13H150	NA584	059 129 717 G	JD5810	68AB1190AA	NA579	77FB1190EA	NB575
8G2232	EF070	13H2934	NA584	59 50 688	AG9790	69BG4676A3A	NA583	77FB1K025AA	NB572
8G2291	CD891	13H3593	NA301	59 50 696	AG9800	69BG4676AA	NA583	77TT3K169A1B	NA585
8G2320	CF070	13H4061	NA473	061A1679010	GJ611	69EB1190AA	NA580	77TT3K169AB	NA585
8G2327	ED890	13H6516	NA473	061A1PA1020	DC636	69EB1190BA	NA580	78EM6051AA	BF580
8G2394	CF470	13H6517	NA473	061A1PA1030	DC636	070 103 383 J	AG8920	78EM6571BA	PA229
8G2402	CF070	13H6862	NB083	061A1PB9010	DC636	070 103 383 K	AG8820	78EM6584AA	JN245
8G2407	CD891	16 06 665	EW870	061A1PC0010	DN240	070 103 383 L	AG8930	78EM6710BA	HC346
8G2493	EF075	16F13	NA301	061A1PC1000	DK100	70HM6051A1A	AH850	78EM6734AA	KJ647
8G2494	EF074	19D1484	NA448	061A1PC1010	DK100	70HM6051C1A	AH850	78EM9448AA	JB842
8G2548	AF470	021 103 609	JH5013	061A1PC3000	DK103	70HM6051F1A	AH850	78FB1K025AA	NB596
8G2550	EF075	021 133 227 H	JA5068	061A1PC3010	DK103	70HM6051G1A	AH860	78GB8507BA	KA606

INTERCHANGE OE → PAYEN

Vergleichsliste OE → Payen • Références croisées 1ère Monte → Payen
Intercambio entre equipo original y Payen

OE reference	▲ Payen	OE reference	▲ Payen	OE reference	▲ Payen	OE reference	▲ Payen	OE reference	▲ Payen
78TM9A454AA	JC364	84FF6051AAA	BM980	86HM6700AA	NA5177	89BM6020AA	JR265	92HM6051AA	AH860
78TM9A454HB	JC364	84FF6051BAA	BM980	86HM6701A1A	NB788	89BM6051B1D	BT110	92HM8507AA	KA289
78TM9A454HC	JC364	84FM6051F1A	BM950	86HM6701AA	NA793	89BM6051B2C	BT110	92SM6051AB	BY740
79TM6051CA	BL080	84FM6051F2A	BM950	86SM6051A3A	BJ440	89BM6051B2D	BT110	92SM6051BA	BJ440
79TM6051DA	BL080	84FM6051F2B	BM950	86SM6051A3C	BJ440	89BM6051C1C	BT140	92SM6051BB	BJ440
79TM6083CA	BL090	84FM6051G1A	BM960	86SM6700A1A	NB959	89BM6051C2B	BT140	92SM6441AA	JD498
79TM6083DA	BL090	84FM6051G2A	BM960	86SM6700AA	NB645	89BM9441AB	JD009	92SM9441AA	JD498
79TM9448DA	JC365	84FM6051G2B	BM960	86SM6701A6A	NB847	89BM9448BA	HA497	93BX6014AA	DT110
79TM9A454BB	JC363	84FM6051H2B	BM980	86SM6701AA	NB847	89EX6014AA	DG050	93FF6700AA	NB984
79TM9A454CB	JC363	84FM6051J1A	BM980	86SX6014AA	DP790	89FF6013AB	ET190	93FF9448AA	JD310
80TM6584AA	JM875	84FM6051J2A	BM980	86SX6014BA	DJ442	89FF6014AB	DT193	93HX6013AA	EH850
80TM6584BA	JM875	84FM6051J2B	BM980	86SX6014CA	DJ441	89FF6051AAA	BT190	93HX6014AB	CH864
81AB1190AA	NB655	84FM6571BA	HR659	86TM6051A4D	BT520	89FF6051ABA	BT200	93HX6014AC	CH865
81AB1190AB	NB655	84FM6571CA	HR659	86TM6051AD	BT520	89FF6051ACA	BT210	93SX6013AA	EA440
81AB9451AA	JE719	84FM6700A1B	NB786	86TM6065EA	HBS057	89FF6065AA	HBS007	93SX6013BA	EA441
81AB9451CA	JE719	84FM6710AD	JJ334	86TM6083A4D	BT510	89FF6441AA	JD240	93SX6014AB	DP790
81AB9451CB	JE719	84FM6710AE	JJ334	86TM6083AD	BT510	89FF6700A2A	NB984	93SX6014BB	DJ441
81AB9451DA	JE719	84FM6710AF	JJ334	86TM6571AA	HR660	89FF6710BA	JJ456	93SX6014EB	DN472
81AB9451DB	JE719	84FM6L270A1A	NB785	86TM6571AB	HR660	89FF6A735AA	NC044	93TX6013AA	ET490
81SM6051N3E	BL340	84FM6L270AA	NB785	86TM6584AA	JN662	89FF6B653AC	NC044	93TX6014AA	DT500
81SM6051R1C	BJ440	84FM9441AB	JC565	86TM6584BA	JN662	89FF6K260AD	JN816	93TX9A454AA	JC364
81SM6051R2D	BJ440	84FM9448AB	JE5022	86TM6701AA	NB564	89FF6K260AE	JN816	93WX6013AA	EX550
81SM6051R3	BJ440	84FM9E583A1B	NB788	86TM6710AA	JJ458	89FF9441AA	JD240	93WX6014AA	DX550
81SM6051R3C	BJ440	84HM6051AC	BN140	86TM9441AD	JD5268	89FF9441BA	JD309	93WX6014BA	DX550
81SM6051R3D	BJ440	85AB1190AA	NB655	86TM9448AA	JE5020	89FF9448CA	JD310	94SM9441AB	JD554
81SM6051R3E	BJ440	85AB1K025AA	NB572	87EM6051AA	BP890	89SF9H486AB	JD188	95BM9448AC	JD545
81SM6065HA	HBS001	85EM6051AA	BP890	87EM6051BA	BP900	89SM9441AB	JC724	95VW6051AA	AA5430
81SM6571A2F	HR661	85EM6051AB	BP890	87EM6051CA	BP910	89SX6014BA	DJ444	95VW6571BA	HR599
81SM6571AF	HR661	85EM6051BA	BP900	88BX6014BA	DT140	90FF6051AAA	BT190	95VW9448AA	JA5069
81SM6584DA	JN332	85EM6051BB	BP900	88EM6701AA	KS696	90FF6051ABA	BT200	95VW9448BA	JD5109
81SM6584FA	JN332	85HM6051A1D+E3859	BN150	88G441	NA448	90FF6051ACA	BT210	95WM 6584 AC	HM5238
81SM6584FB	JN332	85HM6051A2C	BN150	88G548	NA301	90FF6051BBA	BT200	95WM6051C4A	AC5910
81SM6700AA	NB645	85HM6051A2D	BN150	88G561	NA473	90FF6051BCA	BT210	95WM6051D2A	BX550
81SM6701AA	NB847	85HM6051B2C	AH860	88SM6584AA	JN332	91EM6051AA	BP890	95WM6051D2B	BX550
83BM6700A4A	NA576	85HM6051B2E	AH860	88SM6710AA	JJ348	91EM6051BA	BP900	95WM6051D4A	BX550
83BM6700AA	NA576	85HM6051B3C	AH860	88SX6014AA	DN471	91EM6051CA	BP910	95WM6584AC	HM5238
83BM6701AA	NB564	85HM6065BA	HBS056	88TM6051A2A	BT520	91FF6013AA	ET191	95XM6051B2A	BY640
83EM6051AA	BP890	85HM6584AC	JN620	88TM6051A4A	BT520	91FF6051AAA	AB5800	96BM6051A2A	BT140
83EM6051AB	BP890	85HM6584BA	JN620	88TM6051AA	BT520	91FF6051ABA	AB5810	96BM6584A4A	JN105
83EM6051BA	BP890	85TM6051B2A	BL080	88TM6083A2A	BT510	91FF6051ACA	AB5820	96BM6710A2A	JH5015
83EM6051CA	BP900	85TM6051BA	BL080	88TM6083A4A	BT510	91FF6051BAA	BW010	96BX6013AA	EY671
83EM6051CB	BP900	85TM6083B2A	BL090	88TM6083AA	BT510	91FF6051BBA	BW020	96BX6013CA	HC452
83EM6051DA	BP900	85TM6083BA	BL090	88TX6008BA	GT510	91FF6051BCA	BW030	96BX6014AA	DY671
83EM9448AA	JC566	85TM6584CA	JN616	88TX6014BA	DT510	91FF6051CAA	BM950	96FX6013AA	ET192
83HM6584AB	JN620	86AB9451BA	JE719	88WM6051A2J	BT480	91FF6051CBA	BM960	96HM6065AB	HBS078
83HM6584BB	JN620	86BM6051B1A	BC240	88WM6051A2K	BT480	91FF6051CCA	BM980	96MM6051BC	BY650
83HM6701AA	NA793	86BM6051B2A	BC240	88WM6065CA	HBS032	91FF6710AA	JJ463	96MM6065AB	HBS078
83SF9441AA	JD5746	86BM6051B2B	BC240	88WM6065CB	HBS032	91HM9441AA	JA769	96MM6571AE	HR808
83SM6051A3B	BJ440	86BX6014AA	DC240	88WM-6065-CC	HBS032	91SM9448AA	JC790	96MM6571BE	HR809
83SM6710AA	HC452	86EM6700AA	NF780	88WM6571BB	HR342	91SM9448AB	JC790	96MM6710A2A	NA5137
83TM6051EA	BL400	86EX6051AA	BF580	88WM6584AE	JN817	91SM9448BA	JC790	96MM6710AD	JE5025
83TM6051EB	BL400	86EX6051BA	BP890	88WM6710AF	JJ457	91SM9448BB	JC829	96MM6K292A2A	NC048
83TM6083EA	BL410	86EX6051CA	BP900	88WM9441BB	JD542	91XM6051A4D	BY640	96MM6K292A2B	NC048
83TM6083EB	BL400	86EX6051DA	BP890	88WM9448AC	JD543	92HM6013AA	HC285	96MM9441AD	JD5230
84BM6051A1A	BC240	86EX6051EA	BP900	88YX6008AA	EX480	92HM6014BA	CH865	96MX6013AA	EY650
84BM6051A2A	BC240	86HM6700A6A	NA5177	88YX6014AA	DX480	92HM6014CA	CH864	96MX6014AA	DY650

OE reference	▲ Payen	OE reference	▲ Payen	OE reference	▲ Payen	OE reference	▲ Payen	OE reference	▲ Payen
96XM6051B3B	AC5680	0197.37	DJ720	0197.N7	DG050	0197N7	DG050	0199.54	GF322
96XX6014AA	CC5680	0197.42	EL650	0197.N8	EH890	0197N8	GG050	0203.01	BG450
97 253 293	AG9800	0197.46	GL610	0197.N9	DH890	0197N9	DH890	0203.02	BG170
97 256 298	AG9790	0197.49	GM310	0197.P6	GH890	0197P2	GM310	0203.08	BH950
97MF6051AA	AC5290	0197.50	DG052	0197.P9	GF583	0197P6	GH890	0203.23	BL620
97MM6050BC	BY660	0197.51	DM530	0197.R0	GF583	0197P9	GF583	0203.49	BX900
97MM6051BC	BY660	0197.52	GM533	0197.R9	DL831	0197R0	GF583	0203.59	BF290
97MX6014AA	CC5290	0197.55	GL650	0197.S1	DG542	0197R9	DL831	0203.66	BG120
98JV6051BC	AC5260	0197.56	GG452	0197.S2	GG541	0197S1	DG542	0203.67	BG130
98JV6083BC	AC5270	0197.64	GM531	0197.T3	CY082	0197S2	GG541	0203.70	BF580
98MM6051AB	AB5130	0197.72	DF106	0197.T4	CY081	0197T3	CY082	0203.83	BF570
98MM9441AA	JD5290	0197.73	DF106	0197.T6	DY140	0197T4	CY081	0203.84	BF290
98MM9448AB	JD5164	0197.74	DN571	0197.T8	CY082	0197T6	DY140	0204.41+0204.42	HBS017
102 141 27 80	JD182	0197.75	DN571	0197.V1	CY140	0197T8	CY082	0204.51	HBS086
105E1190	NA579	0197.76	EH950	0197.V3	DR630	0197V1	CY140	0204.57	HBS038
105E1190B	NA579	0197.78	GF583	0197.W3	CE5050	0197V3	DR630	0204.67	HBS115
105E4676B	NA583	0197.79	GF583	0197.X3	CC5010	0197W3	CE5050	0204.68	HBS125
105E6020	JR265	0197.81	GF583	0197.X5	CA5830	0197X3	CC5010	0204.72	HBS087
105E6020AB	JR265	0197.84	DM533	0197A2	DF106	0197X5	CA5830	0204.73	HBS088
105E6362A	NA576	0197.91	GF570	0197A6	EH951	0197X8	CY070	0204.74	HBS114
105E6362D	NA576	0197.92	DF572	0197A7	DT010	0197Y1+0209QG+		0204.75	HBS114
105E6K600P	NA576	0197.98	GM533	0197AC	CD5500	0204A4+0204A5	CD5310	0204.80	HBS089
109E1190B	NA580	0197.99	DM530	0197AE	ED5500	0197Y2	GX410	0204.81	HBS254
110 016 03 21	PB256	0197.A2	DF106	0197AG	CG9310	0197Y6	ED5490	0204.84	HBS082
0112.28	HR571	0197.A6	EH951	0197C4	GM533	0197Y7	CD5490	0204.85	HBS112
0112.57	HR574	0197.A7	DT010	0197C6	DM530	0197Y8	CG9750	0204.86	HBS272
0112.58	HR574	0197.C4	GM533	0197C7	DF106	0197Y9	GX392	0204.87	HBS273
0112.59	HR574	0197.C6	DM530	0197C9	DS820	0197Z4	GX392	0204.88	HBS273
0112.72	HR565	0197.C7	DF106	0197E5	DV150	0198.06	DM530	0204.89	HBS260
0112.76	HR564	0197.C9	DS820	0197E7	DV150	0198.11	DM710	0204.90	HBS261
0112.78	HR566	0197.E5	DV150	0197F9	GJ720	0198.15	GF322	0204.93	HBS259
0112.80	HL472	0197.E7	DV150	0197G0	DJ720	0198.30	DM710	0204.95	HBS309
114-092801	JM5285	0197.F9	GJ720	0197G2	DS720	0198.37	DM530	0204.96	HBS272
114-095840	JD5766	0197.G0	DJ720	0197G3	CY130	0198.40	GF583	0204.97	HBS084
0119.13	NF867	0197.G2	DS720	0197G4	CY130	0198.45	GF583	0204.98	HBS277
0119.14	NF867	0197.G3	CY130	0197G6	CY080	0198.46	GF583	0204.A0	HBS278
123 050 00 67	HL196	0197.G4	CY130	0197G7	CY090	0198.47	DF580	0204.A2	HBS359
0127.28	NF844	0197.G6	CY080	0197H0	DV150	0198.50	DM530	0204.A4	HBS359
0127.47	NA5191	0197.G7	CY090	0197H1	DV150	0198.51	GM533	0204A0	HBS278
0164.02	PA349	0197.H1	DV150	0197H3	DS820	0198.53	GG050	204E7657	NA162
0164.30	PA349	0197.H3	DS820	0197H4	DJ720	0198.54	DG050	0209.04	BM530
0165T0	GF492	0197.H4	DJ720	0197H5	GJ720	0198.56	DF580	0209.06	BL650
166 050 00 58	HR5097	0197.H5	GJ720	0197H6	DN590	0198.65	GF570	0209.0S	AD5490
166 140 02 34	JD5135	0197.H6	DN590	0197H8	DS810	0198.80	DF580	0209.0T	AD5500
0197.06	GF583	0197.H8	DS810	0197H9	EH951	0198.84	GF570	0209.0V	AD5510
0197.08	DF580	0197.H9	EH951	0197J0	DY130	0198.89	GF583	0209.0W	AD5520
0197.09	DF580	0197.J0	DY130	0197J1	EY130	0198.91	GF583	0209.12	BH950
0197.10	GF583	0197.J1	EY130	0197J2	DR510	0198.93	DF580	0209.17	BX870
0197.13	GM533	0197.J2	DR510	0197J4	DM533	0198.94	GG050	0209.1E	AD5180
0197.22	DG171	0197.J4	DM533	0197J6	DF106	0198.96	DG050	0209.20	BR510
0197.25	GG050	0197.J9	DM533	0197J9	DM533	0198C3	GM533	0209.21	BL650
0197.26	GG050	0197.K1	DG452	0197K1	DG452	0199.01	DG171	0209.23	BM530
0197.28	GG052	0197.K3	DS731	0197K3	DS731	0199.05	DG052	0209.27	BF100
0197.30	GH890	0197.K4	EH950	0197K4	EH950	0199.06	GG052	0209.28	BG480
0197.31	DH890	0197.K7	DN571	0197K7	DN571	0199.10	GF570	0209.29	BF170
0197.36	GJ720	0197.N5	DG052	0197N5	DG052	0199.37	GF322	0209.30	BG490

INTERCHANGE OE → PAYEN

Vergleichsliste OE → Payen • Références croisées 1ère Monte → Payen
Intercambio entre equipo original y Payen

OE reference	▲ Payen	OE reference	▲ Payen	OE reference	▲ Payen	OE reference	▲ Payen	OE reference	▲ Payen
0209.34	BP900	0209.J0	BF170	0209.Y0	AC5700	0209L5	BG450	0209X8	AC5040
0209.35	BR510	0209.J3	BG120	0209.Y5	BX930	0209L6	BL830	0209X9	AC5051
0209.41	AG5270	0209.J4	BG130	0209.Y6	BX940	0209L7	BL650	0209Y0	AC5700
0209.43	BS810	0209.J8	BV140	0209.Y7	BX950	0209L8	BR510	0209Y5	BX930
0209.46	BN570	0209.K1	BX920	0209.Y8	BX960	0209L9	BY310	0209Y6	BX940
0209.47	BN580	0209.K7	BF600	0209.Y9	BX970	0209N0	AY090	0209Y7	BX950
0209.49	BN780	0209.L2	BF580	0209.Z0	AE5010	0209N1	BS820	0209Y8	BX960
0209.50	BP900	0209.L3	BR510	0209.Z1	AE5030	0209N3	BG540	0209Y9	BX970
0209.51	BP910	0209.L5	BG450	0209A0	BV160	0209N4	BS730	0209Z0	AE5010
0209.56	BX900	0209.L6	BL830	0209A6	BN580	0209N6	AY070	0209Z1	AE5030
0209.57	BX920	0209.L7	BL650	0209A8	BL650	0209N9	BY320	0209Z3	AD5300
0209.58	BL650	0209.L8	BR510	0209A9	BY130	0209P0	AY100	211E7657A	NA162
0209.59	BP890	0209.L9	BY310	0209AJ	AD5130	0209P1	AY120	0232.80P	JM5088
0209.61	BP910	0209.N0	AY090	0209AK	AD5140	0209P4	BY961	0236.09	NF824
0209.69	AG5270	0209.N1	BS820	0209AL	AD5150	0209Q0	BR780	0236.14	NF841
0209.70	BR490	0209.N3	BG540	0209AN	AD5160	0209Q1	BR790	0236.16	NF747
0209.72	BR510	0209.N4	BS730	0209AP	AD5170	0209Q3	AD5100	0236.30	NF817
0209.75	BG450	0209.N6	AY070	0209AQ	AH5080	0209Q8	BX930	0236.44	NF817
0209.76	BM530	0209.N9	BY320	0209AR	AH5090	0209Q9	BX940	0240.99	HBS125
0209.78	BL830	0209.P0	AY100	0209AS	AH5100	0209Q6	AD5310	0242.11	KT738
0209.79	BR510	0209.P1	AY120	0209AT	AH5110	0209R0	BX950	0249.14	JN244
0209.81	BR780	0209.Q0	BR780	0209CO	BS820	0209R1	BX950	0249.19	JN245
0209.82	BR790	0209.Q1	BR790	0209C1	AA5880	0209R2	BX970	0249.25	JN245
0209.83	BS820	0209.Q8	BX930	0209C3	BP890	0209R3	BY140	0249.37	JN302
0209.89	BS810	0209.Q9	BX940	0209C5	BP900	0209R4	BY941	0249.39	JN596
0209.90	BR490	0209.R0	BX950	0209C7	BP910	0209R5	BY950	0249.43	JN292
0209.93	AG5270	0209.R1	BX950	0209C8	BP890	0209R6	BY961	0249.45	JN426
0209.99	BV150	0209.R2	BX970	0209C9	BP900	0209R7	BY970	0249.46	JN544
0209.A0	BV160	0209.R3	BY140	0209CH	AG9030	0209R8	BY981	0249.48	JN547
0209.A6	BN580	0209.R5	BY950	0209CJ	AD5700	0209S0	BX830	0249.53	JN238
0209.A8	BL650	0209.R7	BY970	0209CR	AH5060	0209S1	BX840	0249.54	JN658
0209.A9	BY130	0209.S0	BX830	0209CS	AH5040	0209S2	BX850	0249.55	JN245
0209.C0	BS820	0209.S1	BX840	0209D1	BP910	0209S3	BX860	0249.70	JP045
0209.C1	AA5880	0209.S2	BX850	0209D6	AY110	0209S4	BX870	0249.71	JP043
0209.C3	BP890	0209.S3	BX860	0209D7	BS820	0209S5	BX880	0249.74	JP044
0209.C5	BP900	0209.S4	BX870	0209E1	BL650	0209S6	BX890	0249.76	JN758
0209.C7	BP910	0209.S5	BX880	0209E9	BY120	0209S7	BX900	0249.78	JN426
0209.C8	BP890	0209.S6	BX890	0209EC	AG9310	0209S8	BX910	0249.81	JP041
0209.C9	BP900	0209.S7	BX900	0209F4	BM530	0209S9	BX920	0249.83	JP049
0209.CH	AG9030	0209.S8	BX910	0209F6	BY180	0209T1	BY150	0249.91	JN544
0209.CJ	AD5700	0209.S9	BX920	0209G0	BX870	0209T5	AE5050	0249.95	JM5088
0209.D1	BP910	0209.T1	BY150	0209G1	BP760	0209T6	BY930	0249.99	JM5087
0209.D6	AY110	0209.T5	AE5050	0209G2	BN570	0209T7	BX980	0249.A6	JM5141
0209.D7	BS820	0209.T6	BY930	0209G6	BF290	0209T8	BY150	0249.A9	JM7035
0209.E1	BL650	0209.T7	BX980	0209G7	BF570	0209W3	AE5020	0249.C2	JM7034
0209.E9	BY120	0209.T8	BY150	0209G8	BH950	0209W6	DT010	0249A4	JM5139
0209.F4	BM530	0209.W3	AE5020	0209H8	BG490	0209W7	AD5710	0249A5	JM5283
0209.F6	BY180	0209.W6	DT010	0209H9	BF100	0209W8	BY180	0249A6	JM5141
0209.G0	BX870	0209.W7	AD5710	0209J0	BF170	0209X0	AA5830	0249A9	JM7035
0209.G1	BP760	0209.X0	AA5830	0209J3	BG120	0209X1	AA5840	0249C1	JM5299
0209.G2	BN570	0209.X1	AA5840	0209J4	BG130	0209X2	AA5850	0249C2	JM7034
0209.G6	BF290	0209.X2	AA5850	0209J8	BV140	0209X3	AA5860	0249C5	JM7051
0209.G7	BF570	0209.X3	AA5860	0209K1	BX920	0209X4	AA5870	0249C9	JM7042
0209.G8	BH950	0209.X4	AA5870	0209K7	BF600	0209X5	AC5011	0249E2	JM7052
0209.H8	BG490	0209.X6	AC5020	0209L2	BF580	0209X6	AC5020	0255.50	JN279
0209.H9	BF100	0209.X8	AC5040	0209L3	BR510	0209X7	AC5031	266 016 06 20	AG8500

OE reference	▲ Payen	OE reference	▲ Payen	OE reference	▲ Payen	OE reference	▲ Payen	OE reference	▲ Payen
266 141 00 80	JD5799	0348.S5	JD5830	0349.J8	JD5829	715F6051ABA	AX270	938M6051AG	BW640
266 142 00 80	JD5802	0348C0	JC991	0349.NO	JD5829	715F6051ABB	AX270	938M6051CE	BW650
271 016 05 20	AG8790	0348C8	JD536	0349A6	JC702	715F6051MC	AX270	938M6710AC	JJ531
0295.71	HR5061	0348E5	JD530	0349E2	JB837	715F6584AAB	JN106	938M9441DC	JD266
0301.55	BC630	0348E8	JC135	0349E6	JD531	715F6700AAB	NB452	938X6013AA	EW630
0301.56	BC630	0348F6	JD519	0349E8	JD5764	715F6L270AAA	NB453	938X6013AB	EW630
302E6K206A	JM460	0348F9	JD532	0349F0	JB869	0751.34	DE622	938X6014AA	DW630
0304...33	HC341	0348G4	JD5763	0349G0	JD5878	771M6584AA	JM478	938X6014BA	DW641
0304.05	JJ057	0348H0	JB868	0349H4	JD5190	771M9448AA	JB811	0956.01	PA229
0304.09	JJ057	0348H9	JC759	0349H7	JD5192	771M9448BA	JB812	0956.05	HR300
0304.12	HC347	0348J0	JC991	0349J3	JD5828	781M6051A1A	BJ200	0956.18	HR569
0304.26	JJ283	0348K6	JD5832	0349J4	JD5831	781M6051AA	BJ200	0956.19	HR599
0304.33	HC341	0348K7	JD5879	0415 3728	HR631	785F6L270AAA	NB453	0956.22	HR569
0304.34	JJ283	0348N1	HA5008	432 253 115 A	JE689	788F6L270	NB453	0956.24	HR800
0311.64	HR599	0348N2	HA5008	0470.97	BX740	805F6051AAA	AX270	0956.28	HR599
0313.02	KJ647	0348N4	JD5191	0504.71	AY060	805F6051AAB	AX270	0956.34	HR5080
0313.07	HC346	0348P1	JD5833	0514.14	NF641	805F6051MB	AX270	0956.42	HR5081
0321.27	HG087	0348P9	JD5907	0514.20	NF634	0807.28	NA5035	0956.48	HR5046
0321.35	HG087	0348Q0	JD5906	0514.27	NF780	0807.29	NP067	958M9448AA	JE5021
0321.37	HG087	0348Q5	HA5032	0514.29	NF692	844F6013AAA	EN260	959M6584AA	HM5236
0321.46	HG104	0348R2	HA5029	0514.35	NF780	844F6065AA	HBS008	968M9448AA	JD5313
0321.48	HG093	0348R4	HA5030	0514.38	NF870	844F6584AA	JN460	978M6051CF	BZ490
0321.51	HG092	0348R5	HA5031	0514.74	NF857	844F6710DA	HC451	988M6051BC	AC5800
0321.63	NF694	0348R7	JD5883	600-001130	DT580	849F6700AA	NB855	988M6584AE	JM5154
0326.14	NF369	0348S1	JD5882	607 493	AY400	894F6013AA	ET800	988M6710AG	JH5061
0326.25	NF866	0348S3	HM5289	611 010 01 74	NA5074	894F6014AA	DT800	988M9461AA	JD5311
0326.27	NA5256	0348S4	JD5845	620 280	DX800	894F6700A1A	NB855	1114A78B01000	AD5690
0326.38	BG120	0349.00	JB837	640 016 03 21	JM7027	894F6701AB	NB854	1206.13	KA525
0342.E0	HA5028	0349.03	JB841	640 016 07 20	AG8501	894F6710CA	JJ484	1206A4	KA611
0342E0F520	JD538	0349.06	JB842	640 098 06 80	JD5800	894F6L270AA	NB856	1285.70	NF694
0345L5	JD5880	0349.08	JB842	640 142 05 80	JD5803	894F9461AB	JD064	1339.24	PB259
0348.E8	JC135	0349.23	JB875	652 666	JJ573	904F6584CA	JM5027	0001421V003	JM5162
0348.54	JC135	0349.32	JB954	681F6013AA	HC070	914F9448AA	JD066	1674.42	NF694
0348.63	JB868	0349.34	JC091	681F6020AA	JR265	914F9461AA	JD065	1709.12	JE5044
0348.80	JB836	0349.44	JC566	681F6020AB	JR265	924F6013AA	ET800	1710.07	JE646
0348.89	JC759	0349.46	JB869	0682.44	CJ631	924F6013BA	ET800	1710.09	JE647
0348.91	JC750	0349.47	JC423	0000686	JH5049	924F6014AA	DT802	1723.63	JD520
0348.96	JD529	0349.49	JC415	688	EH684	924F6014BA	DT801	02029X0	AA5430
0348.C0	JC991	0349.52	JC712	0000689	JH5032	924F6051AA	BT800	02090H	AG9750
0348.C8	JD536	0349.59	JC415	0691.85	DY740	924F6051AA	BT800	02090N	AG9710
0348.E5	JD530	0349.60	JB837	691M6014BA	JB837	928F9441DB	JD264	02090P	AG9730
0348.E8	JC135	0349.63	JC702	701H6700A1A	NA576	928M6051AG	BW630	02090Q	AG9720
0348.F0	HA510	0349.70	JC415	701M6700A1A	NA576	928M6051BH	BW640	02090R	AG9740
0348.F6	JD519	0349.76	JD230	701M6700AA	NA576	928M6065BC	HBS031	02090S	AD5490
0348.F9	JD532	0349.78	JC423	711M6013AA	HC070	928M6065BD	HBS031	02090T	AD5500
0348.H0	JB868	0349.86	JC566	711M6014AA	HC070	928M6584C1B	JN950	02090V	AD5510
0348.J0	JC991	0349.92	HA512	711M6014CA	DJ202	928M6584CB	JN950	02090W	AD5520
0348.K9	JD5832	0349.94	JB841	711M6051CA	BJ200	928M6700B5A	NB959	02090X	AH5040
0348.N1	HA5008	0349.A6	JC702	715F6008AAB	FX270	928M6700BA	NB959	02090Y	AH5060
0348.N2	HA5008	0349.E2	JB837	715F6008AAC	FX270	928M6734AA	KG664	02090Z	AH5050
0348.N4	JD5191	0349.E6	JD531	715F6008AAD	FX270	928M6K292B5A	NB958	02091A	AH5070
0348.P1	JD5833	0349.F0	JB869	715F6008AAE	FX270	928M6K292BA	NB958	02091E	AD5180
0348.Q5	HA5032	0349.H4	JD5190	715F6013ABB	HC326	928M6K929B5A	NB958	2109.08	LV851
0348.R2	HA5029	0349.H7	JD5192	715F6014AAB	CX270	928M9441GB	JD265	2109.11	LV847
0348.R4	HA5030	0349.J3	JD5828	715F6014AAC	CX270	928X6014BA	DW631	2724E6701A	NA793
0348.R5	HA5031	0349.J4	JD5831	715F6051AAC	AX270	938M6051AA	BW630	2730E67811	HC060

INTERCHANGE OE → PAYEN

Vergleichsliste OE → Payen • Références croisées 1ère Monte → Payen
Intercambio entre equipo original y Payen

OE reference	▲ Payen	OE reference	▲ Payen	OE reference	▲ Payen	OE reference	▲ Payen	OE reference	▲ Payen
2730E6781A	HC060	04112-97206-000	CG5290	06110-PT5-020	DS705	10101M9025	GN170	10101W3827	GM821
2730E6781C	HC060	004219U	AY170	06110PWA010	CG9180	10101M9026	GN170	10101W4125	GG724
2730E6K600C	NA576	0004551V000	HBS460	06110-PWA-010	CG9180	10101M9525	GC272	10101W4126	GG724
2733E6584A	JM478	0004553	CC5350	06110PY3000	DV090	10101M9526	GC272	10101W5725	FJ495
2733E9441A	JA613	06110P01000	CG7890	06110RBB000	CG5810	10101M9527	GC272	10101W5726	FJ495
2733E9448A	JB811	06110P03000	DV350	06111P08000	EV020	10101N4725	GC385	10101W7525	GC272
2733E9448B	JB812	06110P08000	DV020	06111P30000	EV050	10101N7227	FJ051	10105AA010K	DV544
2925E4676B	NA583	06110-P0D-010	CG5350	06111P8AA01	EG5770	10101P6926	GC388	10105AA011K	DV544
3020E6051A	AF880	06110-P0D-010 + CS	GV830	06111-P8A-A01	EG5770	10101P6927	GC388	10105AA012	DV544
3020E6K260A	JM460	06110P0D010+CS	GV830	06111PDAE00	EG6210	10101P6928	GC388	10105AA020	DV543
3020E9448A	JA475	06110P0D030	CG5350	06111-PDA-E00	EG6210	10101P7125	GC385	10105-AA020	DV543
0003086V003	AC5660	06110-P0D-030	CG5350	06111PLAE01	FD5230	10101P7126	GC385	10105AA020K	DV543
0003093V001000000	HA5034	06110P13000	DV340	06111-PLA-E01	FD5230	10101P7127	GC385	10105AA021HS	DV450
3121.24	NF825	06110P14000	DV030	06111P08000	EV020	10101P7128	GC388	10105AA060	FF5760
3121.26	NA5204	06110P1K010	CG7900	06114PND010	EG5810	10101P7185	GC388	10105AA060K	CF5760
3121.27	NA5205	06110P27010	DV351	06114RBA000	EG5810	10101Q1125	GC383	10105AA070	FG5290
3244.9U	HC341	06110-P2A-010 + CS	GY861	06120P8AA11	CG9170	10101Q1726	GC385	10105AA070K	CG5290
3345.11	NF072	06110P2A010+CS	GY861	06120-P8A-A11	CG9170	10101T6025	GM821	10105AA280	FG5590
3681E010	AG210	06110P2RA02	DY863	0007189V001000000	JD5823	10101T6026	GM821	10105AA280K	CG5590
3681E011	AG210	06110P30010	DV041	10101-0W026	FF5690	10101T7025	GG724	10105AA290K	CG5580
3681E012	AG210	06110P3F902	DV050	10101-37J27	FF5600	10101T8026	GG724	10105AA351	FG5581
3681E048	AG900	06110P3RD01	DV021	10101-52H26	FF5600	10101T8226	GL770	10105AA351K	CG5581
3681E049	AG900	06110P3RD01+ CS	GV021	10101-74N26	GW421	10101T8226HS	DL770	10105AA530	FG5600
3681E050	AG910	06110P5M000	CG5760	10101-74N28	GW421	10101T8227	GL770	10105AA530K	CG5600
3681E051	AG910	06110P5M000 + 06111P5P	FG5760	10101-8H726	FF5541	10101T8228	GM581	10105KA110	FG7980
3681E052	AG910	06110PAAL00	CG5780	10101-9E025	GV311	10101T8229	GM581	10944AA003	AG5610
3681E053	AG910	06110-PAA-L00	CG5780	10101A8625	FJ051	10101T8295	GM581	11042-4F225	DV542
3681E054	AG910	06110PBY000	CG7870	10101A8725	FJ491	10101U0125	FJ051	11042-4M526	CD5250
3681E055	AG910	06110PCX000	CG8010	10101A8727	FJ491	10101U0126	FJ051	11042-6N226	CF5541
3681E056	AG910	06110PCX000+06111PCX020	FG8010	10101A8728	FJ491	10101U0625	FJ495	11042-73Y85	DP951
3681E057	AG910	06110PDEE00	CG5761	10101AX527	FG7880	10101U0626	FJ495	11042-74N25	CD5280
3681E058	AG910	06110-PDE-E00	CG5761	10101C6825	GJ360	10101U0627	FJ495	11042-9C625	CG5530
3681E059	AG910	06110PDEE00 + 06111PCB	FG5761	10101C68252627	GJ360	10101U0628	FJ495	11042A8725	CJ491
3681E060	AG910	06110PDTE00	DV022	10101C6826	GJ360	10101U6025	FJ491	11042A8727	CJ491
3681E061	AG910	06110-PDT-E00	DV022	10101C8625	GJ363	10101U6026	FJ491	11042A8728	CJ491
3681E062	AG910	06110PHM000	CG7960	10101C8626	GJ363	10101U6027	FJ495	11042-AD225	CD5260
04111-46044	FG5100	06110PHM000 + 06111PHM	FG7960	10101C8627	GJ363	10101U6028	FJ495	11042AE225	CF5540
04111-97206-000	FG5290	06110PK2010	DY863	10101D3527	GM766	10101U6029	FJ495	11042-AE225	CF5540
04112-02050	CD5360	06110PK2010	DY863	10101D3529	GM766	10101U6725	FJ491	11042AE226	CF5540
04112-02060	CG5490	06110PLC010	CG5790	10101D9727	GR360	10101U6726	FJ491	11042-AE226	CF5540
04112-08010	CD5370	06110PLD010	CG5790	10101D9728	GR360	10101U9427	FJ491	11042C6825	DJ360
04112-11121	DV331	06110PNA010	CG5810	10101D9785	GR360	10101U9428	FJ491	11042C8625	DJ363
04112-15030	DL340	06110PNB000	CG5811	10101G3425	GK750	10101U9625	FJ491	11042C8626	DJ363
04112-20040	DZ350	06110-PNB-000	CG5811	10101G3426	GK750	10101U9626	FJ491	11042C8627	DJ363
04112-20050	CD9270	06110PNB000 + 06114PNA	FG8131	10101G3427	GK750	10101V1426	GC388	11042C8628	DJ363
04112-22070	CG9110	06110P03000	DV350	10101G5525	GR360	10101V1428	GC388	11042CA026	CG6130
04112-24042	DD950	06110P08000	DV020	10101H3925	GN170	10101V1429	GC388	11042-CA026	CG6130
4112-24042	DD950	06110PR7010 + 06111PR7	FG7860	10101H3926	GN170	10101VC125	FF5740	11042D1325	DK840
04112-24043	DD950	06110PR7020	CG7860	10101H3927	GN170	10101-VC125	FF5740	11042D1326	DK840
04112-50121	CF5860	06110PRBA00	CG8130	10101H3928	GN170	10101W1725	GL310	11042D1327	DM598
04112-64143	CD5350	06110PRBA00 + 06114PRB	FG8130	10101H7226	GC272	10101W1726	GL310	11042D1328	DM598
04112-64272	CD5340	06110PSHE00	CD5231	10101H8625	GK750	10101W1727	GL310	11042D1329	DM598
04112-67024	CG5540	06110-PSH-E00	CD5231	10101H8627	GK750	10101W1728	GL310	11042D3527	DM766
04112-74562	CD5330	06110PSME00	CD5230	10101H8825	GN170	10101W2125	FJ495	11042D9727	DR360
04112-74581	CG9140	06110-PSM-E00	CD5230	10101H9526	GC272	10101W2225	FJ495	11042D9728	DR360
04112-87727	DE865	06110PT5020	DS705	10101M6825	GC272	10101W2625	FJ491	11042D9790	CC5750

OE reference	▲ Payen	OE reference	▲ Payen	OE reference	▲ Payen	OE reference	▲ Payen	OE reference	▲ Payen
11042G3425	DK750	11042V6225	DM570	11044AA572	AG5590	11044N4210	BC380	11115-27010-A0	AD5370
11042G3426	DK750	11042VC125	CF5740	11044AA573	AG5590	11044N4220	BC380	11115-28012	AF5840
11042G3427	DK750	11042-VC125	CF5740	11044AA603	AG5600	11044P3000	AJ580	11115-46045	AG5100
11042G5525	DR360	11042W1725	DL310	11044BX000	AG7880	11044P3001	AJ580	11115-50032	AF5031
11042H3925	DN170	11042W1726	DL310	11044C8600	BJ360	11044P3002	AJ580	11115-64140	AD5350
11042H3926	DN170	11042W1727	DL310	11044C8602	BJ360	11044P3003	AJ580	11115-64141-01	AD5350
11042H3927	DN170	11042W1728	DL310	11044CD005	AE5910	11044P3004	AJ580	11115-64200-01	AD5340
11042H3928	DN170	11042W3125	CJ586	11044D0100	BK830	11044P8600	BC380	11115-64200-03	AG5240
11042H7226	DC271	11042W3126	CJ586	11044D0101	BK830	11044P8601	BC380	11115-67050-05	AG5230
11042H8625	DK750	11042W3827	DM821	11044D0102	BK830	11044U0800	AJ490	11115-71010+11115-	
11042H8627	DK750	11042W4125	DG724	11044D0103	BK830	11044U0801	AJ490	71011+11115-73040+	
11042H8825	DN170	11042W4126	DG724	11044D0104	BK830	11044U0802	AJ490	11115-73041	BL822
11042J1836	DM581	11042W7525	DC271	11044D0200	BK840	11044U0803	AJ490	11115-74120	AG9140
11042M3025	DN170	11042W7526	DC271	11044D0201	BK840	11044U0810	AJ490	11115-75030+11115-75031	BZ170
11042M6725	DC271	11042Y8525	DC380	11044D0202	BK840	11044U0811	AJ490	11116-20010	BZ350
11042M9525	DC271	11044-1C710	AG5190	11044D0203	BK840	11044U5720	AJ580	11116-20031	AG9100
11042M9526	DC271	11044-1C711	AG5190	11044D0204	BM590	11044U8700	AJ580	11121-05E00	JH5097
11042N4225	DC380	11044-2J615	AD5280	11044D0205	BM590	11044U8710	AJ580	11121A3500	JH005
11042N4725	DC386	11044-38U00	AF5700	11044D0210	BM590	11044U8720	AJ580	11121A3501	JH005
11042N7227	CJ051	11044-38U05	AF5710	11044D1704	BM760	11044V4212	BM570	11121AA000	JJ360
11042P6928	DC388	11044-5M313	AD5260	11044D1705	BM760	11044V5200	BM570	11121AA010	JH050
11042P7125	DC386	11044-5M320	AD5250	11044D1706	BM760	11044V5201	BM570	11121C7800	JJ151
11042P7126	DC386	11044-8J107	AG6130	11044D1707	BM760	11044V5202	BM570	11121D0100	JJ265
11042P7127	DC386	11044-8M020	AB5630	11044D1710	BM760	11044V5212	BM570	11121D0101	JJ265
11042P7128	DC388	11044-9C601	AG5170	11044D2800	BP580	11044V7200	BW620	11121E3000	JH031
11042Q1726	DC386	11044-9C602	AG5180	11044D2801	BP580	11044VC100	AF5740	11121E3001	JH031
11042S9125	DJ353	11044-9C603	AG5250	11044D2802	BP580	11044VC101	AF5750	11121F6505	HC460
11042S9126	DJ353	11044A8600	AJ050	11044E3101	AJ580	11044W0402	BG720	11121V1700	JJ281
11042T6025	DM821	11044A8702	AJ490	11044E3102	AJ580	11044W1700	BL310	11121V5000	JJ299
11042T6026	DM821	11044AA001	BN550	11044G5500	BR360	11044W1701	BL310	11121W4400	JH5100
11042T6027	DM821	11044AA003	BN550	11044G5501	BR360	11044W1702	BL310	11122AA000	JH5101
11042T7025	DG724	11044AA011	BN550	11044G5502	BR360	11044W4000	BG720	11132-01M25	HC5010
11042T7026	DG724	11044AA012	BN550	11044H3901	BN170	11044W4001	BG720	11132H5025	HC259
11042T8325	DJ353	11044AA013	BN550	11044H3925	BN170	11044W7000	BM820	11141-71C00	AG5260
11042T8326	DJ353	11044AA030	BN550	11044H3926	BN170	11044W7001	BM820	11189-71C00	JH886
11042T8327	DJ353	11044AA100	AG5280	11044H3927	BN170	11044W7002	BM820	11189A78B0000	JM5263
11042T8328	DJ353	11044-AA100	AG5280	11044H7200	BC270	11044W7003	BM820	11213-0G010	JM5148
11042U0126	CJ051	11044AA110	BV450	11044H7201	BC270	11044W7012	BM820	11213-28021	JM7036
11042U6025	CJ491	11044AA111	BV450	11044H8660	BK750	11056-31U01	HBS404	11213-64061	JM5146
11042U6026	CJ491	11044AA112	BV450	11044H8701	AJ580	11056-31U01 (8x)	HBS404	11214-46010	HM5273
11042U6027	CJ491	11044AA113	BV450	11044H8720	AJ580	11056-4M500	HBS422	011228	HR571
11042U6028	CJ491	11044AA114	BV450	11044H9820	BC270	11056-9C601+11056-7C000	HBS195	11251PA5000	JH171
11042U6725	CJ491	11044AA120	AG5280	11044H9821	BC270	11056AD200	HBS374	11251PA5003	JH171
11042U6726	CJ491	11044AA241	AF5760	11044H9822	BK750	11056G2401	HBS194	11251PA5004	JH171
11042U9425	CJ491	11044AA355	AG5210	11044KA010	BR560	11056V7200	HBS190	11251PA6000	JH171
11042U9625	CJ491	11044AA360	AG5290	11044KA221	AG7980	11057H11500	HBS432	11251PA6003	JH171
11042U9626	CJ491	11044-AA360	AG5290	11044L2000	BL770	11095AA041	HBS405	11251PA6004	JH171
11042V1326	DC380	11044AA361	AG5290	11044N2202	AJ050	11095AA041 (12x)	HBS405	11251PB2000	JH171
11042V1327	DC380	11044AA362	AG5290	11044N2203	AJ050	11100-58810	CG5510	11251PC6000	JJ271
11042V1426	DC388	11044AA363	AG5290	11044N2210	AJ050	11100-61820	CG5470	11251PC6010	JJ271
11042V1427	DC388	11044AA364	AG5290	11044N2211	AJ050	11100-71811	CG5511	11251PE0003	JJ309
11042V1428	DC388	11044AA443	AG5200	11044N2212	AJ050	11100-71812	CG5511	11251PE0004	JJ309
11042V1429	DC388	11044AA482	AG5580	11044N2213	AJ050	11100-83816	CG5480	11251PE0010	JJ309
11042V5925	DM570	11044AA483	AG5580	11044N2214	AJ050	11115-20010	BZ340	11251PE0020	JJ309
11042V5926	DM570	11044AA521	AG6150	11044N2215	AJ050	11115-20031	AG9090	11251PE2003	JJ309
11042V5927	DM570	11044-AA521	AG6150	11044N2215AS	AJ490	11115-22060	AG9110	11251PE2004	JJ309

INTERCHANGE OE → PAYEN

Vergleichsliste OE → Payen • Références croisées 1ère Monte → Payen
Intercambio entre equipo original y Payen

OE reference	▲ Payen	OE reference	▲ Payen	OE reference	▲ Payen	OE reference	▲ Payen	OE reference	▲ Payen
11251PE2010	JJ309	12251PB2000	BE120	12279D0100	NJ284	12729	EG571	13270V0600	JN416
11251PE2020	JJ309	12251PBYJ01	AG7870	12279H1000	NJ021	0012882V001000000	JD5821	13270V5000	JN570
11251PH3000	JJ365	12251PC0010	BN240	12279H2300	NJ004	13042A3500	NJ045	13270V7210	JN837
11251PH7000	JJ364	12251PC1000	BK100	12279H2301	NJ004	13042A3510	NJ045	13270W5800	JM005
11251PK1010	JJ390	12251PC1020	BK100	12279H2310	NJ004	13042A8600	NJ045	13270Y7000	JM044
11251PT0000	JJ417	12251PC6662	BL360	12279H2311	NJ004	13042D0100	NJ285	13272AA000	JN610
011257	HR574	12251PC6663	BL360	12279R4600	NJ056	13042D0101	NJ285	13272AA021	HM5255
011258	HR574	12251PC7003	BM920	12279R4601	NJ056	13043T7200	NJ369	13272AA031	HM5253
011259	HR574	12251PCX004	AG8010	12279R4610	NJ056	13119-85C10	JD5770	13294KA000	JN656
011272	HR565	12251PD6003	BM920	12279R4611	NJ056	13207C8700	PA884	13294KA060	JN681
011276	HR564	12251PE0003	BM990	12279T7200	NJ287	13207D0100	PA079	13294KA061	JN681
011278	HR566	12251PE0004	BM990	12279T7201	NJ287	13207D0101	PA079	13294KA070	JN656
011280	HL472	12251PE0010	BM990	12279T7202	NJ287	13207D0111	PA079	13510D0100	NJ280
11903	KS696	12251PE0013	BM990	12279V1700	NJ287	13207D4200	PA874	13510E0700	NJ278
11912	KS696	12251PE0023	BM990	12341P08000	JN857	13207H2300	KJ454	13510H1000	NJ022
011913	NF867	12251PE3003	BM990	12341P0A000	JN918	13207H2301	KJ454	13510H1001	NJ022
011914	NF867	12251PE3004	BM990	12341P13000	HM5266	13207H2310	KJ454	13510H1010	NJ022
11994	KJ779	12251PE3014	BM990	12341PA1000	JN512	13207H7200	KJ454	13510R2000	NJ267
12040PCX305	HM5258	12251PE0004	BM990	12341PA1010	JN583	13207H7201	KJ454	13510V5000	NJ368
12209PA5003	PA373	12251PE0010	BM990	12341PA1020	JN583	13207H7210	KJ454	13510V7200	NJ765
12209PA5004	PA373	12251PG6003	BP630	12341PB2000	JN318	13207KA000	PA655	14009V5201	JD152
12209PA6003	PA373	12251PH3003	BP740	12341PB2690	JN318	13207KA001	PA655	14032-AX600	JD5841
12209PD2003	PA630	12251PH4003	BN450	12341PC1000	JN434	13207V1700	JN434	14035-57J01	JD5761
12209PD2004	PA630	12251PH7003	BP640	12341PC1010	JN434	13207Z5000	PA192	14035-9C601	JD5762
12210PA6003	PA286	12251PH7004	BP640	12341PC6000	JN605	13207Z5001	PA192	14035AA000	JC595
12210PA6004	PA286	12251PHM004	AG7960	12341PE0000	JN562	13211KA000	PA656	14035AA131	JD5767
12210PC1003	PA424	12251PK1660	BS110	12341PE0660	JN574	13211KA001	PA656	14035AA132	JD5767
12210PD2003	PA528	12251PK1661	BS110	12341PE0661	JN574	13270-31V10	JM7037	14035-AA132	JD5767
12210PD2004	PA528	12251PK1662	BS110	12341PE2000	JN580	13270-57J01	JM5138	14035AA281	JD5768
12210PJ7004	PA969	12251PL2003	BR650	12341PE2003	JN580	13270-99B00	JM5281	14035AA290	JD5767
12210PM7004	PB156	12251-PLC-003	AD5230	12341PG6000	JN632	13270-9C601	JM5282	14035D0100	JC317
12210PT2004	PB353	12251PLZD00	AG9840	12341PH3000	JN649	13270A0600	JM005	14035D2000	JC605
12210PZ1004	PB355	12251PLZD10	AG9850	12341PH4000	JN605	13270AA000	JN611	14035H8901	JC214
12211PA6003	PA288	12251PLZD20	AG9860	12341PH7000	JN633	13270AA031	HM5252	14035K0700	JA008
12211PA6004	PA288	12251PM3003	BR540	12341PK1000	JN769	13270AA050	HM5256	14035KA000	JC967
12211PD2004	PA529	12251PM5000	BR540	12341PK2000	JN649	13270-AD200	JM5137	14035KA040	JC967
12211PE0003	PA531	12251PM5S01	BV350	12341PK2010	JN649	13270BX000	JM5298	14035L2000	JC473
12211PE0004	PA531	12251PM5S02	BV350	12341PLC000	JM5134	13270C6800	JN597	14035M000	JC140
12211PJ7004	PA970	12251PM7003	BS880	12341PM3000	JN679	13270C8600	JN597	14035N3200	JB776
12211PT2004	PB354	12251PNA004	AG5810	12341PM6000	JN744	13270C8610	JN597	14035N3500	JC128
12211PZ1004	PB356	12251POA004	BV830	12341PM7000	JN925	13270D0100	JN433	14035P6501	JC128
12251P01004	AG7890	12251-POA-004	BV830	12341PNA000	HM5267	13270D0101	JN433	14035P7501	JC128
12251P08004	BV020	12251PR3000	BV050	12341P08000	JN857	13270D4200	JN653	14035U0100	JA008
12251P13004	BV340	12251PR3004	BV040	12341-POA-000	JN918	13270D4210	JN654	14035U0101	JA008
12251P14A02	BV030	12251PR4004	BS890	12341PR3000	HM5228	13270E3000	JM044	14035U0105	JA008
12251P1K000	AG7900	12251PR4A12	BS890	12341-PR3-000	HM5228	13270E3001	JM044	14035U2800	JA007
12251P1K003	AG7900	12251PR7A010M1	AG7860	12341PR4A00	JN757	13270G2500	JM086	14035U6700	JA007
12251P1KE01	AG7900	12251PT0004	BS700	12341PT0000	JN755	13270G5500	JN723	14035V5202	JC581
12251P2J004	BV020	12251-PWA-J01	AG9180	12341-PWA-000	HM5275	13270H1000	JM008	14035W1500	JC126
12251P30004	BV040	12251PY3003	BV090	12341PY3000	HM5248	13270H1010	JM008	14035W1700	JD5760
12251P30014	BV040	12251IRBB004	AG5810	12551P5TG00	BZ440	13270M0100	JN494	14035W1701	JD5760
12251P5M004	AG5760	12261P5A000	AG5740	12551P5TG10	BZ450	13270R7400	JM669	14035-W1701	JD5760
12251-P8A-A01	AG9170	12261PY3003	BV100	12551P5TG20	BZ460	13270R8800	JN416	14035W5300	JA008
12251PA0000	BG710	12279A4600	NJ056	12664	CE542	13270R8810	JN416	14035W7060	JC126
12251-PAA-A02	AG5780	12279C8600	LV501	12665	CG571	13270U2000	JM005	14035W7061	JC126
12251PAAA02	AG5780	12279D0100	NJ284	012728	NF844	13270U2010	JM005	14036D4200	JC788

OE reference	▲ Payen	OE reference	▲ Payen	OE reference	▲ Payen	OE reference	▲ Payen	OE reference	▲ Payen
14036V5000	JC471	18116PC6000	JC405	019854	DG050	020906	BL650	22311-26100	CG8290
14036W0401	JC133	18116PC6010	JC405	019856	DF580	20910-26D00	FG8290	22311-37320	AG5690
14036W7060	JC133	18153PM3003	JF119	019864	GM533	20910-38C01	FF5070	22321-22000	HBS387
14037V5000	JC472	18212SA0003	JE625	019865	GF570	020912	BH950	22327-26000	HBS454
14038KA050	JC700	18212SA7003	JF021	019872	DM530	020917	BX870	22441-22012	JM5277
14140-52G00	JD5769	18212SB2960	JF024	019880	DF580	020920	BR510	22441-22013	JM5277
016402	PA349	18212SB2961	JF024	019883	DF572	20920-023A00	CG8290	023280P	JM5088
016430	PA349	18671	KG664	019884	GF570	20920-02B00	CG5360	023609	NF824
016454	KG5012	019706	GF583	019888	GM533	20920-22A00	DY730	0000023614	NF841
17105P00T01	JD051	019708	DF580	019889	GF583	20920-22C10HS	DY735	023616	NF747
17105P07004	JD074	019709	DF580	019891	GF583	20920-23A00	DY710	023630	NF817
17105P08004	JD075	019710	GF583	019893	DF580	20920-23B00	CG5950	023644	NF817
17105PE0000	JC521	019713	GM533	019894	GG050	20920-37A00	DZ280	023717P	JH5041
17105PE0010	JC521	019722	DG171	019896	DG050	20920-38C00	CF5070	024099	HBS125
17105PH3000	JC652	019725	GG050	019897	CG9710	020921	BL650	024903	JP041
17105PL2000	JC791	019726	GG050	019901	DG171	020923	BM530	024914	JN244
17105PL2003	JC791	019728	GG052	019905	DG052	020927	BF100	024919	JN245
17105PM3003	JC863	019730	GH890	019906	GG052	020928	BG480	024925	JN245
17105P07004	JD074	019731	DH890	019910	GF570	020929	BF170	024931	JN303
17105P08004	JD075	019736	GJ720	020301	BG450	020930	BG490	024937	JN302
17105PT2004	JC883	019737	DJ720	020302	BG170	020931	BP890	024943	JN292
17105-PWA-007	JD5838	019742	EL650	020304	BP890	020932	BP900	024945	JN426
17146-PWA-004	JD5839	19749	GM310	020308	BH950	020934	BP900	024946	JN544
17170-87301	JD5741	019750	DG052	020323	BL620	020935	BR510	024948	JN547
17171-16051	JD5771	019751	DM530	020349	BX900	020941	AG5270	024953	JN238
17173-21020	JD5738	019752	GM533	020359	BF290	020943	BS810	024954	JN658
17173-23010	JD5837	019755	GL650	020366	BG120	020946	BN570	024955	JN245
17173-28010	JD5171	019756	GG452	020367	BG130	020947	BN580	024970	JP045
17173-87101	JD5745	019764	GM531	020370	BF580	020949	BN780	024971	JP043
17173-87301	JD5742	019772	DF106	020383	BF570	020950	BP900	024974	JP044
17177-21020	JD5159	019773	DF106	020384	BF290	020951	BP910	024976	JN758
17177-23020	JD5836	019774	DM571	020451	HBS086	020955	BP890	024978	JN426
17177-28010	JD5170	019775	DM571	020457	HBS038	020956	BX900	024981	JP041
17177-87101	JD5744	019776	EH950	020467	HBS115	020957	BX920	024983	JP049
17177-87301	JD5743	019778	GF583	020468	HBS125	20958	BL650	024991	JN544
18110PA1000	JA077	019779	GF583	020472	HBS087	020959	BP890	024993	JP041
18110PE0000	JC534	019781	GF583	020473	HBS088	020961	BP910	024995	JM5088
18110PE0010	JC534	019784	DM533	020474	HBS114	020969	AG5270	024999	JM5087
18110PG6003	JC674	19790	DL650	020475	HBS114	020970	BR490	025001P	JD5189
18115P2A003	JD5748	019791	GF570	020480	HBS089	020972	BR510	025550	JN279
18115-P2A-003	JD5748	019792	DF572	020481	HBS254	020975	BG450	28521-22020	JD5751
18115P5L003	JD5750	019798	GM533	020484	HBS082	020976	BM530	0029571	HR5061
18115P5L004	JD5750	019799	DM530	020485	HBS112	20978	BL830	29986L	JB837
18115-P5L-004	JD5750	019806	DM530	020486	HBS272	020979	BR510	30021L	JN238
18115P5SG01	JD5749	019811	DM710	020487	HBS273	020981	BR780	030155	BC630
18115-P5S-G01	JD5749	019813	DF580	020488	HBS273	020982	BR790	030156	BC630
18115PC6000	JC404	019819	DF580	20489	HBS260	020983	BS820	30197J	HC341
18115PC6010	JC404	019830	DM710	020490	HBS261	020989	BS810	030405	JJ057
18115PH3000	JC688	019837	DM530	020493	HBS259	020990	BR490	030409	JJ057
18115PH7003	JC687	019840	GF583	020495	HBS309	020993	AG5270	030412	HC347
18115PK2000	JC688	019845	GF583	20496	HBS272	020999	BV150	030426	JJ283
18115PM3003	JC674	019846	GF583	020497	HBS084	21014V5000	KA675	30430K	JB836
18115P00004	JD052	019847	DF580	020498	HBS277	21014V5001	KA675	030433	HC341
18115PT0004	JC884	19850	DM530	20711A08000	JE014	21114KA000	KA725	030434	JJ283
18115PT3A21	JC885	019851	GM533	20711W7100	JE747	22311-22130	BY730	030455	JH5107
18115-PWA-004	JD5840	019853	GG050	020904	BM530	22311-23000	AG5070	31164	HR599

INTERCHANGE OE → PAYEN

Vergleichsliste OE → Payen • Références croisées 1ère Monte → Payen
Intercambio entre equipo original y Payen

OE reference	▲ Payen	OE reference	▲ Payen	OE reference	▲ Payen	OE reference	▲ Payen	OE reference	▲ Payen
31302	KJ647	40232M5611	NJ552	91212PH1004	NJ311	101803	KV123	110449C608	AG5250
031307	HC346	40232N7100	NJ107	91212PH1013	NJ311	101827	AN350	112130Q010	JM7042
031326	PA349	041110B010	FG7480	91212PH1661	NJ311	102078	JA899	112330	JN758
032127	HG087	041110H012	FF5781	91212PH7003	NK023	102538	JM669	114812	JN635
032135	HG087	041110N010	FG7600	91212PH7013	NK023	103331	AN350	115094	BE620
032137	HG087	041120B010	CG7480	91212PJ5003	NJ982	104662	NA298	115276	JN588
032146	HG104	43232B5000	NJ387	91212PJ5013	NJ982	105257	JM261	115309	JA899
032148	HG093	43232F6100	NJ885	91212PT0003	NK159	107022	JM669	117005	KG664
032151	HG092	43232P4500	NJ274	91212-PT0-004	NJ134	107028	JH565	119941	KJ779
032163	NF694	43252M7000	NJ419	91212PT0004	NJ312	107234	AN350	120607	KA606
0003019700000032449	HC341	43252M7001	NJ419	91213PC6000	NJ313	108811	BE620	120613	KA525
32449U	HC341	44892M	JB836	91213PC6003	NJ313	109952	JC507	120623	KA606
032614	NF369	45766E	DL611	91213PD2004	NJ313	110196	JM669	120646	KA611
032625	NF866	47097	BX740	91213PE1721	NJ313	110420W025	CF5690	120691	KA835
32638	BG120	48364N	BF170	91213PH1003	NJ313	110422Y925	CF5720	123415	JE331
32852Q	NF692	50471	AV060	91213PH1004	NJ313	110424M725	CB5610	125065	JH565
33111C6200	NJ450	051415	NF678	91213PH7003	NJ933	110424M726	CB5610	127920	NA301
034854	JC135	051418	NF678	91213PH7004	NF678	110424M785	CB5610	00128534 00	HC341
034863	JB868	051420	NF634	91213PH7013	NJ933	110426N226	CF5541	129966	JN652
034880	JB836	051427	NF780	91213PL2003	NJ933	110428M025	CB5630	130455	BP990
034889	JC759	051429	NF692	91213PT0003	NJ134	110429C625	CG5530	131951	NF692
034891	JC750	051435	NF780	91214PB2003	NJ309	110440C402	BW420	132176	BE620
034896	JD529	051438	NF870	91214PC6003	NJ312	110440C410	BW420	132241	BE620
034903	JB841	051474	NF857	91214PC6013	NJ312	110440C412	BW420	132702W201	JM5318
034906	JB842	54041	DY070	91214PD2004	NJ312	110440W000	AF5690	132702Y510	JM5317
34908	JB842	60523	JN811	91214PE1721	NJ312	110441C710	AG5190	132704M500	JM5064
034923	JB875	68010	EG5130	91214PH1003	NJ312	110441C711	AG5190	132704M700	JM5245
034932	JB954	68244	CJ631	91214PH1004	NJ312	110441E420	BV310	132708H300	JM5267
34934	JC091	69185	DY740	91214PH1661	NJ312	110441P010	BW620	132708J112	JM5316
034944	JC566	75134	DE622	91214PH3751	NJ312	110441P012	BW620	132709C601	JM5282
034946	JB869	77500	NA448	91214PH7003	NJ675	110441P060	BW620	132709C602	JM5282
034947	JC423	080724	NA5260	91214PH7013	NJ675	110441P063	BW620	132709C605	JM5282
034949	JC415	080728	NA5035	91214PL2003	NJ675	110442J616	AD5280	132709C606	JM5282
034959	JC415	080729	NP067	91214PL2004	NJ675	110442J617	AD5281	133910	LC292
034960	JB837	90003P5TG00	HBS282	91214PR4A01	NJ312	110442Y900	AF5720	133924	PB259
034963	JC702	90005PT0003	HBS284	095601	PA229	110442Y905	AF5730	134697	JD565
034970	JC415	90006PT0003	HBS284	095605	HR300	110444M700	AB5610	139029	JM261
034976	JD230	90910-02075	HBS397	095618	HR569	110444W000	AE5880	0139259	JH5070
034978	JC423	90910-02088	HBS445	095619	HR599	110444W005	AE5890	140359C601	JD5762
034986	JC566	90910-02091	HBS425	095622	HR569	110446N201	AF5540	143456	NA774
034992	HA512	90910-02102	HBS450	095628	HR599	110446N202	AF5540	145103	LT832
034994	JB841	90910-02132	HBS452	095634	HR5080	110447B000	AF5690	146092	JA502
035198011C	EX995	91203PA5004	NJ254	095642	HR5081	110447J500	AB5690	146129	NA294
38314S	BF100	91203PG6003	NJ254	095648	HR5046	110448H800	AG9930	153063	JA626
38333V	BF170	91212P0A004	NA5242	100552	BG820	110448H801	AG9940	153068	JA625
38342D2100	NJ689	91212PA5004	NJ072	101010W026	FF5690	110448H802	AG9950	0000160069	HBS458
40227M0205	NJ082	91212PAA01	NA5242	101014M7256	FB5610	110448H803	AG9960	000160320	AA5430
40227M3000	NJ082	91212-PAA-A01	NA5242	101014M728	FB5610	110448H804	AG9970	164046	JB841
40227M3005	NJ082	91212PC6003	NJ311	101014M785	FB5610	110448H805	AG9980	170912	JE5044
40227M5601	NJ639	91212PD2004	NJ311	101018H726	FF5541	110448J107	AE5910	170915	JE189
40227M5605	NJ639	91212PE0000	NJ381	101041	JH565	110448M010	AB5630	170920	JE5069
40232B9500	NJ386	91212PE0003	NJ381	101072	JA898	110448M020	AB5630	170921	JE5071
40232M0205	NJ083	91212PE0662	NJ381	101096	JR349	110449C601	AG5170	170923	JE5070
40232M0215	NJ083	91212PE1721	NJ381	101097	NB696	110449C602	AG5180	170933	JE5072
40232M5600	NJ552	91212PG7A01	NK005	101550	NA294	110449C603	AG5250	171007	JE646
40232M5610	NJ552	91212PH1003	NJ311	101670	KV124	110449C607	AG5180	171009	JE647

OE reference	▲ Payen	OE reference	▲ Payen	OE reference	▲ Payen	OE reference	▲ Payen	OE reference	▲ Payen
171032	JE145	275720	HL462	551169	JN238	607467	BH860	608124	ED770
171034	JE126	275721	HL469	558132	BM850	607471	BJ170	608584	CG914
171045	JE189	275727	EG920	562645	HR659	607472	BY340	608632	BY270
171058	JE189	275728	DM631	563145	BL650	607473	BY260	608804	AB5030
171730Q010	JD5846	275743	HL463	596842	BM530	607491	AY220	608805	AB5010
171770Q010	JD5845	275769	DK642	599609	JM875	607492	JM5197	608806	AB5020
172363	JD520	301028	NF882	599891	JN279	607493	AY400	608807	BY270
176404.A2	HR397	302087	JH434	602087	JH434	607498	AG9570	608809	BY240
179010	JE189	303098	KG664	602216	JB894	607499	JM5121	608810	AY220
186718	KG664	312103	NF334	602512	JM483	607626	BK470	608814	BY300
192633	KG664	312109	NF334	605123	CG914	607627	JN694	608815	BY260
205481	AE330	312113	NF115	607034	AY850	607628	JN694	610704	NB469
210908	LV851	315706	KJ779	607097	CG914	607630	JM950	610705	NB469
210910	HG108	321103	HR800	607098	EG914	607631	JN776	610706	NB469
210911	LV847	328410	NB575	607208	HBS416	607642	HM5294	611409	NB291
211126	JR147	328637	NB575	607234	HBS112	607643	JM950	614801	NB691
213358	JE289	334511	NF072	607237	HBS160	607646	JP016	614804	NB691
214622	JA510	346626	NF185	607238	HBS160	607647	JP016	614805	NB690
216138	JE289	372412	NB775	607242	HBS002	607653	JD5204	614808	NB691
217291	AK280	406307	JC365	607248	HBS035	607655	JN245	614809	NB469
217757	AK260	430118	NA869	607254	HBS003	607664	JN041	614810	NB469
217782	NB984	430132	NA581	607256	HBS054	607666	JM956	614811	NB698
218239	JA510	0432207	HC060	607296	HBS252	607668	JM521	614812	NB469
221443B000	NF678	444409	BP110	607327	HBS287	607670	JN068	614813	NB701
223114A000	AG9880	458600	EW630	607400	BR010	607672	JM523	614814	NB691
223114A010	AG9870	463224	JB926	607401	BK470	607685	HBS003	614815	NB469
223114A020	AG9890	463412	BD070	607402	BR030	607686	HBS074	614816	EB950
223214A000	HBS434	463587	JJ065	607407	AB5540	607749	JM5085	614817	NB701
224808	LT726	463846	JB917	607410	AB5360	607923	HBS298	614818	NB691
0228195	KG664	463999	JN279	607411	BL550	607933	HBS003	614819	NB806
231698	CA3130	469336	NB854	607413	BM380	607939	HBS036	614820	NB698
0242110	KT738	0490525	HR630	607414	BL550	607952	HBS074	614821	NB698
244680	KG664	0494262	EM850	607415	BK470	607960	HBS055	614822	NJ450
245291	BG130	501676	CD770	607416	BP800	607966	BL020	614825	NC004
245546	JN303	501677	FD770	607417	BR010	607971	BJ170	614826	NB691
245585	BG120	502855	DX550	607418	BR020	607972	JN923	614827	NB700
247088	JH409	509215	EG091	607419	BR030	607973	BV950	614829	NB806
247606	JM350	510924	CE330	607420	BR020	607974	AY840	614830	NB698
270656	NZ997	514744	CE330	607423	BN010	607975	AY860	614838	NB431
270676	DD070	517276	CG901	607430	BN040	607980	AB5030	614855	NA5209
270679	EH445	517615	JM154	607431	BP810	607981	JM521	614860	NA5230
270686	DD072	0517826AC	CC5562	607432	BP820	607983	BS720	620280	DX800
270688	DD073	519179	CX650	607443	BR030	607984	BK020	628188	NB628
270689	DK643	520706	CK261	607444	BR010	607985	BN040	636836	NC006
271393	HM5293	520715	CK260	607445	BN010	607986	BP810	636838	DY241
271435	DM631	524199	NA987	607446	BR020	607987	BP820	636839	NB807
271734	HA5042	525520	EG210	607449	BS260	607988	BP800	636840	NJ449
271736	HA5040	525521	CG210	607451	BN040	607989	BL550	636841	DY240
272395	JD5898	525856	FD770	607455	BK020	607990	BK470	638177	JM5092
274171	JA323	525857	CD770	607458	BL010	607991	BM380	638181	NB628
274173	JM356	529365	NA987	607459	BL020	607992	BK480	638182	BT530
275254	DY362	0000530022	HR599	607460	BL030	607994	BT530	638186	NB628
275578	DD070	535554	BM850	607461	BB610	607995	BL010	638187	NB628
275580	EH445	0543491	JM875	607462	AK300	607996	BL020	638192	JN693
275581	EH445	0546325	HC418	607464	BY330	607997	BL030	638194	NB807
275719	DK642	546841	JH409	607466	BY350	607998	BW170	638196	NA5069

INTERCHANGE OE → PAYEN

Vergleichsliste OE → Payen • Références croisées 1ère Monte → Payen
Intercambio entre equipo original y Payen

OE reference	▲ Payen	OE reference	▲ Payen	OE reference	▲ Payen	OE reference	▲ Payen	OE reference	▲ Payen
638198	JR5030	652274	JJ615	849193	JD5255	850673	JE5024	1005441	HR808
638199	NA5108	652577	JH5005	849196	JD5147	850675	JD5332	1005442	HR809
638225	JR5030	652582	JJ120	849213	JD5256	850677	JD5329	1005491	CC5870
638252	JN924	652585	JJ200	849216	JD5334	850696	JA415	1005891	JC152
638260	JN929	652586	JJ200	849218	JD5330	850699	JA499	1005899	JA5069
638265	JP009	652587	JJ385	849219	JD5413	850709	JD5765	1005900	JD5109
638266	JP008	652590	JJ120	849504	JD458	850716	JC280	1008718	DP790
638269	NF637	652593	JJ459	849509	JD5203	850719	JC283	1008725	DJ441
638287	JR5030	652594	JH5019	849510	JD5202	854929	JE119	1008733	DJ441
638643	JM550	652596	JH5058	849511	JC436	854933	JE120	1008739	DJ444
638644	JN344	652599	JJ459	849515	JD5117	859093	BY270	1010101A25	GK441
638646	JN453	652600	JJ536	849518	JD5399	878777	NB714	1010101A26	GK441
638648	JN626	652601	JH5019	849520	JD459	880146	JC365	1010101A27	GK444
638649	JN693	652602	JJ574	849521	JD5277	881202	JM333	1010101A28	GK444
638720	JN626	652603	HCS008	849522	JD5903	881428	KF600	1010101M25	GK441
638721	JN693	652604	JH5119	849530	JD5331	881452	LR922	1010101M26	GK441
638725	JN693	652605	JH5057	849934	JD5300	902071	HC027	1010101M85	GK441
638727	JN626	652606	HCS008	850500	JC756	915386	BR510	1010101M86	GK441
638733	JP018	652610	JH5037	850510	JD5148	930597	JN285	1010101Y25	GS050
638736	JP009	652611	JH5005	850516	KG5337	930781	HR800	1010101Y85	GS050
638737	JP008	652613	JH5036	850521	JD5398	933723	DK610	1010103G25	GR662
638741	JM5048	652634	JJ572	850522	JC824	933724	DK611	1010103G26	GR662
638742	JM5059	652635	JJ616	850536	JC280	933725	DK612	1010103G27	GR662
642452	HR336	652636	JJ617	850537	JC281	935599	JN513	1010105B26	GR160
642500	HR5048	652637	HCS008	850540	JC283	944667	NF526	1010105B27	GR160
642504	HR5088	652665	JH5052	850541	JC282	947706	NA585	1010105B28	GR160
642518	HR336	652666	JJ573	850542	JC436	972965PM	JD245	1010105E75	GR360
642519	HR291	652669	JJ575	850543	JC437	974068	NB775	1010105E7576	GR360
642520	HR336	652672	JH5096	850544	JC283	982724	KG5012	1010105E76	GR360
642522	HR342	693693	JN694	850600	JC757	986955	JH310	1010105N25	GG725
642524	HR343	694223	BL410	850601	JC756	986964	KS176	1010106F25	GM760
642525	HR343	701815	BN200	850602	JE5029	986965	JR087	1010107F27	GM597
642526	HR343	702219	BL650	850606	JD455	986984	JA752	1010107F86	GM597
642527	HR342	710003	PA229	850607	JC823	987057	KG393	1010108S25	FJ495
642528	PA543	724507	NA380	850608	JC437	987112	KH007	1010108S26	FJ495
642529	HR291	724520	NA380	850609	JD5765	988803	JE480	1010109N25	GR662
642530	HR336	750521	BK610	850610	JA415	994155	NF115	1010109W25	GM580
642531	PA658	752673	BN200	850611	JD187	1000389	BT140	1010109W26	GM581
642533	DY241	758503	BK610	850613	JC282	1000438	JN105	1010109W2627	GM581
642540	HR280	763181	BR690	850615	JC281	1000439	JN105	1010110B25	GL761
642542	HR5096	795073	FN353	850616	JC436	1002814	JH5015	1010110W27	GR662
646260	NC065	795135	GE622	850618	JA499	1004302	NC048	1010111A25	GK440
646262	NB697	795192	DE622	850619	JC155	1004421	HBS078	1010111A26	GK440
646263	NB700	795193	CN353	850632	JD430	1004457	NA5137	1010111A27	GK440
646265	NB700	795365	DR040	850633	JC823	1004459	JE5025	1010111A28	GK440
646266	NB734	795389	DP990	850634	JC824	1004476	JD5230	1010111A88	GK446
646267	NB697	795393	GP990	850645	JC282	1004928	NA5001	1010111M25	GK440
646268	NA5271	0800947	BL090	850646	JD456	1005062	JA5068	1010111M26	GK440
646269	NB884	0800950	BL080	850648	JD459	1005063	JD5232	1010111M27	GK440
646270	NB697	0801191	KA289	850655	JD451	1005254	BX800	1010111M85	GK440
646271	NB884	812265M1	NB684	850656	JD450	1005258	BX810	1010111M86	GK440
646289	NB700	831450	JJ080	850663	JD5201	1005261	BX820	1010111M87	GK440
646299	NA5174	833347	HR660	850665	JD275	1005262	JP003	1010111M88	GK440
646904	KK5646	835878	BC650	850666	JD274	1005293	EC340	1010111W25	FJ495
646910	NA5223	836184	JC305	850668	JD448	1005303	NA5133	1010112G25	GM577
652261	JJ615	836583	JN285	850672	JE5017	1005304	JH5013	1010112G85	GM572

OE reference	▲ Payen	OE reference	▲ Payen	OE reference	▲ Payen	OE reference	▲ Payen	OE reference	▲ Payen
1010114A25	GK446	1010178E27	GT050	1090949	JD5312	1104215B86	DL761	1104274N28	DW420
1010115B25	GL760	1010184A25	GS612	1096227	AA5940	1104215G25	DM821	1104274Y25	DP970
1010115B26	GL760	1010184M25	GK447	1096228	AA5950	1104217A26	DP580	1104278A25	DV991
1010115B27	GL760	1010187A25	GV990	1096230	AA5960	1104217M26	DK445	1104278E26	DT050
1010115B28	GL760	1010187A26	GV990	1096253	HR5082	1104217M27	DK445	1104284A25	DS612
1010115B85	GL760	1010188A25	GS610	1097083	AC5860	1104219B25	DR161	1104287A00	DV990
1010115G25	GM821	1011782	DY641	1099084	AC5890	1104219P85	DM574	1104287A25	DV990
1010117A26	GP580	1012728	BT110	1099778	JM5037	1104220G25	DR662	1104287A26	DV990
1010117C27	GR661	1012744	BY660	1100328	AB5120	1104220G26	DR662	1104287G25	DW540
1010117C28	GR661	1015368	EY650	1101405	BX550	1104220H25	DR660	1104288A25	DS610
1010117M26	GK445	1015368OR	EY650	1102674	HBS296	1104221E85	DM593	1104288A26	DS612
1010117M27	GK445	1015368OR96MX6013AA	EY650	1102676	HBS296	1104221E87	DM593	1104299B25	DY900
1010119B25	GR161	1015369	DY650	1104201A25	DK441	1104221P26	DM574	1104400QAD	AE5210
1010120G25	GR662	1016149	EY671	1104201A26	DK441	1104222G25	DG725	1104401M00	BK440
1010120G26	GR662	1016155	DY671	1104201M25	DK441	1104222G26	DG725	1104401M01	BK440
1010121P26	GM574	1022122	ET192	1104201M26	DK441	1104222J25	DV250	1104401M02	BK440
1010121P85	GM574	1022220	AC5680	1104201M85	DK441	1104223E85	DM596	1104401Y00	BS050
1010122G25	GG725	1022869	CC5680	1104201M86	DK441	1104223E87	DM596	1104402N01	BS760
1010122G26	GG725	1031000	AC5290	1104201P25	DM570	1104224E25	DM761	1104402N02	BS760
1010122J25	GV250	1032209	NB788	1104201P26	DM570	1104224E85	DH060	1104402N03	BS760
1010122J26	GV250	1033121	JJ609	1104201Y25	DS050	1104224E87	DH060	1104405B00	BR160
1010123E87	GM596	1035247	CC5290	1104203G25	DR662	1104225A25	DK445	1104405B26	DR160
1010124C25	GR661	1035729	BY650	1104203G26	DR662	1104229R25	DM762	1104405B27	DR160
1010124E25	GM761	1044867	JE5021	1104203G27	DR662	1104229R26	DM762	1104405B28	DR160
1010124E87	GM765	1048093	JD5311	1104205B26	DR160	1104229R27	DM762	1104405B29	DR160
1010125A25	GK446	1050369	AY400	1104205B27	DR160	1104230R25	DS771	1104405E00	BR360
1010130R26	GS771	1050370	AY410	1104205B28	DR160	1104231M26	DK449	1104405E20	BR360
1010137J27	FF5600	1050371	AY420	1104205B29	DR160	1104231V26	CG8210	1104406P00	BM570
1010140F25	GS770	1053830	AC5800	1104205E25	DR360	1104232F26	DM574	1104406W00	BJ350
1010140L25	GW620	1053902	JD5313	1104205H25	DK750	1104237J27	CF5600	1104406W01	BJ350
1010140P27	GS910	1056737	HR5033	1104205N25	DG725	1104240F25	DS770	1104406W02	BJ350
1010143G25	GS200	1061468	JM5154	1104207F25	DM590	1104240P25	DS910	1104406W03	BJ350
1010143G26	GW540	1064459	JES025	1104207F26	DM597	1104240U27	CF5700	1104406W04	BJ350
1010143G27	GW540	1068119	AB5800	1104207F86	DM597	1104242E25	DM574	1104408B00	BR160
1010143G28	GS200	1068120	AB5810	1104209N25	DR662	1104243G25	DS200	1104408B01	BR160
1010143G85	GS760	1068121	AB5820	1104209W25	DM580	1104243G26	DS200	1104408B02	BR160
1010152H26	FF5600	1068123	BW020	1104209W26	DM581	1104243G85	CC5750	1104409W00	BM580
1010154A25	GP580	1068124	BW030	1104209W2627	DM581	1104250W25	DJ353	1104409W01	BM580
1010154A85	GP580	1071744	BZ490	1104210B25	DL761	1104251L25	CJ586	1104410B00	BL760
1010155M25	GR240	1072018	AB5130	1104210W27	DR662	1104254A25	DP580	1104410B01	BL760
1010157Y25	GP960	1072063	JD5290	1104211A25	DK440	1104257L25	CJ586	1104410B02	BL760
1010157Y26	GP960	1072066	JD5164	1104211A26	DK440	1104257Y25	DP960	1104410W01	BL260
1010160A25	GK448	1073369	HBS032	1104211A27	DK440	1104260A25	DK447	1104410W02	BR660
1010161W25	GG724	1077686	NC048	1104211A28	DK440	1104261W25	DG724	1104413C00	BR360
1010163A26	GK448	1078498	JH5008	1104211E25	DK831	1104263A25	DK446	1104413C01	BR360
1010164Y25	GT051	1078524	JM5016	1104211M25	DK440	1104263A26	DK447	1104413C02	BR360
1010165A25	GK447	1078528	NC086	1104211M26	DK440	1104264Y25	DT051	1104416A06	BP580
1010166A25	GK447	1078707	JH5061	1104211M27	DK440	1104265A25	DK446	1104422J10	BV250
1010170J25	DV541	1079925	HBS243	1104211M85	DK440	1104265M25	DR240	1104422J11	BV250
1010170J26	GV540	1079926	HBS243	1104211M86	DK440	1104266A25	DK446	1104422J12	BV250
1010170J28	GT050	1085617	BY640	1104211M87	DK440	1104270J25	DV541	1104422J15	BV250
1010171J25	GV440	1086431	HR5033	1104211M88	DK440	1104270J26	DV540	1104422J16	BV250
1010173Y25	GP950	1086437	JD5151	1104212G25	DM577	1104270J28	CY250	1104422J17	BV250
1010174N28	GW420	1089765	HBS358	1104215B25	DL761	1104270L25	DW620	1104427L00	AJ580
1010174Y25	GP970	1089772	JD5220	1104215B26	DL761	1104271J25	DV440	1104431U00	AG8240
1010178E26	GT050	1089844	JM5104	1104215B85	DL761	1104273Y25	DP950	1104431U05	AG8230

INTERCHANGE OE → PAYEN

Vergleichsliste OE → Payen • Références croisées 1ère Monte → Payen
Intercambio entre equipo original y Payen

OE reference	▲ Payen	OE reference	▲ Payen	OE reference	▲ Payen	OE reference	▲ Payen	OE reference	▲ Payen
1104431U10	AG8220	1105916	AB5310	1131835	AB5340	1257113	NB716	1327050A00	JN647
1104431U15	AG8210	1105919	AB5320	1131836	AB5350	1257174	JC152	1327051J10	JN838
1104437J00	AF5600	1105920	AB5330	1136695	KA5021	1257221	NA5001	1327053J01	JN798
1104438U00	AF5700	1105921	AB5340	1137860	JA5085	1257257	BG940	1327053J02	JN798
1104438U01	AF5700	1105922	AB5350	1138392	HA5020	1257264	JD310	1327053J05	JN798
1104438U02	AF5700	1112101F10	JJ367	1139357	NA5028	1266796	JC440	1327053J13	JN830
1104438U05	AF5710	1112101F15	JJ368	1141575	JM5155	1271483	JN302	1327056E00	JN653
1104438U06	AF5710	1112105E00	JH5097	1142359	NA5259	1271699	JA5044	1327056E10	JN654
1104438U07	AF5710	1112122P00	HC460	1142502	JD5866	1273501	HR596	1327057Y10	JN829
1104440F00	BS770	1112953	HC5004	1143317	LK5004	1275055	JA5043	1327057Y20	JN829
1104440F10	BS770	1113050A00	HC458	01143554	PA349	1276191	BK640	1327059E00	JN687
1104440L26	BW620	1113150A00	HC458	1145953	NA5258	1276424	NA581	1327067S00	JN640
1104440P00	BS910	1113201B25	HC443	1148115	JD5829	1276425	NA581	1327099B00	JM5281
1104441B00	BY900	1113201B26	HC443	1149707	JD5227	1288544	HR646	1327153F00	JN880
1104442L00	BR870	1113201B27	HC443	1151934	DW642	1302345	AC5940	1327653Y00	NJ207
1104443G01	BS200	1113201M25	HC442	01157880	PA349	1304201M00	NJ288	1327653Y10	NJ207
1104443G02	BS200	1113211	LK5004	01160861	NF470	1304216A05	NJ285	1327653Y11	NJ207
1104443G03	BS200	1114160A00	AG5260	01170213	NB775	1304216A10	NJ283	1328017	BW680
1104444G01	BS760	1114160B00	BT900	01172413	NF115	1304216V00	NJ765	1328018	BW690
1104444G02	BS760	1114160B01	BT900	1198045	NA5013	1304242L00	NJ765	1328019	BW700
1104444G03	BS760	1114169G01	AG8180	1206655	HR5063	1305949	AG9560	1330893	CH832
1104445V00	BS910	1114171C00	AG5260	1207615	NC086	1306333	NA5016	1332644	BK640
1104445V11	BS910	1114175F10	AG8120	1207619	NB785	1306630	HR641	1338204	KT738
1104448L01	BM590	1114185AF1	AG5710	1210586	FY291	1308385	AE5320	1350607	NA5192
1104453Y00	BP950	1114185FA0	AG5710	1211161	LK5004	1311960A00	JC868	1350608	NA5191
1104453Y10	BP950	1114186FA1	AG5730	1211759	LK5005	1311985C10	JD5770	1351001B00	NJ363
1104454T06	AC5760	1114285FA0	AG5720	01216330	NF539	1315154	JJ538	1351001M00	NJ286
1104454T07	AC5770	1114286FA1	AG5740	1218027	NF634	1316639	NA5190	1351016A00	NJ280
1104455M01	BR240	1117453	NA5030	1219337	NA5147	1316801M00	NJ951	1351016V10	NJ280
1104457Y00	BP960	1117685FA0	JM5307	1220025	JM5153	1317772	HR646	1351018V10	NJ280
1104460U10	BS830	01117811	NB775	1227901B00	NJ364	1320701M00	PA203	1351019V00	NJ765
1104460U15	BS840	01118681	KJ779	1227901B11	NJ364	1320701M01	PA203	1351040F00	NK106
1104470J01	BV540	1118685FA0	JM5308	1227901M00	NJ287	1320701M10	PA203	1351043G00	NJ831
1104470J02	BV540	01118693	KG664	1227942L00	NJ287	1320742L00	PA933	1351053J10	NK106
1104474Y00	BP970	1118969G00	JM5312	1227943G00	NJ829	1320753Y00	PB681	1351071J00	NJ222
1104477A00	BV990	1118971C00	JN886	1227953J10	NJ284	1320753Y10	PB681	1351077A05	NJ765
1104484A00	BS610	1118975F01000	JM5309	1228836	HC5004	1320770J05	HR767	1351077A10	NJ765
1104485M00	BR240	1118977E00000	JM5304	1229267	HBS369	1320770J15	HR768	1351088G10	NJ368
1104486J00	BV440	1119162	NA5157	1229474	AG8310	1320777A10	PB071	1366786	JA5040
1104487A00	BV990	1119182	NA5157	1229872	AC5940	1320781W00	PA933	1366787	JA5039
1104487G01	BW540	1119194	AC5940	1229877	AD5130	1321041	DF106	1370373	AG8320
1104487G02	BW540	1119284	JD5299	1229878	AD5140	1326381	JD5865	1378217	JB917
1104487G03	BW540	1119878	JM5158	1229879	AD5150	1327001B01	JN564	1378218	JE248
1104488A00	BS610	1120389	AA5970	1229880	AD5160	1327001B02	JN840	1378475	BX090
1105601M03	HBS409	1120390	AA5980	1229881	AD5170	1327001E00	JN624	1378645	BD070
1105601M04	HBS409	1120391	AA5990	1231144	NA5130	1327001M00	JN494	1378646	BK640
1105601M05	HBS409	1121231	AD5020	1231928	HBS368	1327001M01	JN665	1378854	JD345
1105621V02(x4)+		1122617	AC5940	1235994	JM7034	1327005E01	JN687	1378864	JJ065
11056V50047(x9)	HBS443	1124372	AD5220	1238067	NA5031	1327005E02	JN722	1378870	JN635
1105641B00	HBS110	1126120	JM5184	1247478	JD611	1327016A00	JN528	1378879	JC440
1105653Y00	HBS187	1127417	JD5219	1250941	AA5980	1327016A01	JN528	1378909	JN279
1105657J00	HBS111	1131305	LK5005	1254375	HA5030	1327017C00	JN702	1378912	JC886
1105689J00	HBS188	1131831	AB5300	1254376	HA5031	1327017C10	JN702	1397727	AA5630
1105771	AC5800	1131832	AB5310	1255011	NF554	1327030R00	JN743	1397728	AY260
1105772	AB5260	1131833	AB5320	1256130	AA5950	1327040F00	JN739	1403071J05	JC761
1105914	AB5300	1131834	AB5330	1256146	AA5940	1327043G01	JN724	1403257Y10	JC999

OE reference	▲ Payen	OE reference	▲ Payen	OE reference	▲ Payen	OE reference	▲ Payen	OE reference	▲ Payen
1403278A00	JD244	1433463	AC5640	1524544	CH851	1606169	CB5240	1606618	EK484
1403278A10	JD244	1433467	AC5650	1524545	CH861	1606170	EB5541	1606619	DP820
1403501	JC317	1433473	AC5350	1524546	HC285	1606171	CG9570	1606626	EK470
1403501B25	JC460	1433477	AC5360	1525251	HR630	1606172	EG9570	1606630	CY811
1403501B26	JC460	1436760	JM5096	1528222	HR633	1606184	HC295	1606639	ES720
1403501M25	HA366	1436761	JM5097	1535996	CH851	1606221	CE5930	1606640	EK470
1403502	JC605	1436822	CC5900	1535997	CH851	1606228	HC288	1606641	DS260
1403509W00	JC473	1437237	JJ611	1535998	CH861	1606230	HC417	1606646	EK485
1403510G00	JC668	1437343	JM5098	1536187	JR265	1606239	CG9590	1606651	EK484
1403510W00	JC580	1437384	JD5858	1537316	HC060	1606245	CD5800	1606653	EB950
1403510W01	JC580	1438209	AH850	1537831	JN106	1606246	CE5950	1606663	EK482
1403511M25	HA371	1438210	AH860	1540074	JM875	1606247	CH5030	1606664	DP820
1403540F00	JC901	1439570	NA5099	1541298	AX270	1606254	CD5840	1606665	EW870
1403553F00	JC997	1451231	JA769	1545266	JM510	1606278	CH5031	1606668	ET820
1403553J00	JD134	1454118	KG664	1564630	NA162	1606281	DK020	1606669	DM380
1403557J01	JD5761	1454231	HC070	1565558	JE719	1606295	DY300	1606670	DK480
1403557Y00	JD001	1470910	HR630	1568734	JB799	1606314	CK302	1606672	DP802
1403570J16	JD135	1472925	CH851	1568834	HR630	1606316	EG851	1606673	DP800
1403570J20	JD134	1472927	NA793	1572045	NA579	1606318	DN010	1606674	DL550
1403571J15	JD110	1472928	JA770	1576302	BF580	1606322	DN041	1606675	DN041
1403574Y00	JD093	1472929	JA768	1576410	PA229	1606328	DN041	1606676	DK470
1403584A00	JC869	1474550	HR630	1576414	JN245	1606353	DY271	1606679	EK470
1403599B002	JC875	1475408	JM510	1576433	KJ647	1606355	EG851	1606681	DK471
1403601B25	JC459	1475468	JM510	1576433#	KJ647	1606365	CB5241	1606683	EK485
1403601B26	JC459	1478505	NA579	1576449	JB842	1606371	CK302	1606686	EK484
1403601M03	JC745	1481472	NA576	1576837	JC364	1606380	DY232	1606687	DS720
1403602	JC475	1481477	NA793	1579537	HR633	1606381	CY211	1606688	ES720
1403615M25	HA372	1481478	NA576	1579664	NA580	1606382	CC5460	1606689	DP802
1403640F00	JC900	1482324	NA585	1579665	NA585	1606399	EB5670	1606697	DS260
1403642L04	JC653	1482504	NA580	1579666	NA585	1606455	CD5820	1606701	DW170
1403643G00	JC806	1482506	NA583	10010001580701	AF240	1606460	HC417	1606717	DJ172
1403653J00	JC995	1483146	NA580	1582255	FX270	1606462	DR012	1606719	EK481
1403653Y00	JD091	1483200	HC285	1583656	JC365	1606463	CB5140	1606720	EJ161
1403670J01	JC760	1483213	JR265	1591014	BL090	1606464	EB5140	1606728	EK484
1403671J00	JC761	1485838	JM5119	1591015	BL090	1606501	EK481	1606729	DP803
1403671J05	JC761	1486852	HR630	1596529	HR630	1606511	DK470	1606730	DS261
1403677A00	JC870	1486853	HR630	1599050	AX270	1606512	DK470	1606762	DY231
1403699B00	JC876	1487220	HM5061	1602017	DJ202	1606528	ET820	1606767	EY280
1407424	JR265	1487221	JH5051	1602029	CH854	1606529	EK470	1606769	DY241
1410042	EG091	1487385	DJ202	1602030	CH851	1606530	EJ161	1606770	DY250
1414052G00	JD5769	1490506	HR630	1602032	CH861	1606559	DK480	1606774	DY250
1414060A10	JC867	1490525	HR630	1602148	EA440	1606560	EK470	1606787	EC100
1414060A20	JC867	1490528	HC070	1606034	CY210	1606570	DM380	1606790	EY230
1414163B00	JC859	1492228	HC285	1606057	EB5671	1606575	DL550	1606819	CY221
1414164B00	JC861	1492244	NA5140	1606076	DY253	1606576	EK470	1606820	CY220
1415103	EC633	1494179	CH851	1606077	EC101	1606584	DK480	1606834	EC130
1415152	JA475	1494181	CH851	1606078	CG9580	1606585	DM380	1606835	EY300
1416233	JA613	1498320	HC5004	1606093	CB5141	1606586	DL550	1606880	DY270
1416691	JB811	1190001513801	BW300	1606094	CB5240	1606587	DK470	1606881	DY271
1416692	JB812	1518859	NA162	1606095	CE5920	1606591	AX270	1606912	DP806
1421437	JM478	1519666	AX270	1606096	EB5360	1606593	CX270	1606914	DY240
1427825	DY571	1519667	FX270	1606097	CB5360	1606595	ET820	1606919	DY251
1432109	JH5050	1519669	CX270	1606126	EC102	1606596	EB5240	1606923	EY230
1432297	HC060	1521100	JA769	1606127	DY255	1606604	DK470	1606924	HC5007
1432478	EW802	1521106	JA769	1606130	CB5540	1606615	DK471	1606953	DY254
1432874	KK5484	1524543	CH851	1606167	CB5141	1606617	EK482	1606993	DY251

INTERCHANGE OE → PAYEN

Vergleichsliste OE → Payen • Références croisées 1ère Monte → Payen
Intercambio entre equipo original y Payen

OE reference	▲ Payen	OE reference	▲ Payen	OE reference	▲ Payen	OE reference	▲ Payen	OE reference	▲ Payen
1606999	DY251	1663816	KG664	1959975	AC5750	2091039A01	FG8090	2248975	EZ660
1611351	JE719	1663822	NB958	1959976	AC5760	2091046	KG664	2248976	EZ690
1612101	JD5746	1665138	JJ463	1959977	AC5770	02091200	BH950	2248982	BZ660
1612203	BP890	1665146	ET190	1962292	HBS432	2092002B00	CG5360	2248983	BZ670
1612205	BP900	1665147	DT193	1970800	DF580	2092002F00	CG8060	2248984	BZ680
1612206	BP900	1669254	NA5177	1970900	DF580	2092022A00	DY730	2248985	DZ660
1612229	JC566	1669785	HR599	1971000	GF583	2092022C10HS	DY730	2248987	BZ690
1612236	NF387	1669794	AA5430	1972500	GG050	2092026E00	CG8291	2248988	BZ700
1613315	NB655	1669798	JM5030	1972600	GG050	2092027C00	CG7910	2248989	BZ710
1620378	HR630	1708585	AB5660	1972800	GG052	2092035A02	CG8090	2248990	DZ690
1620861	HR659	1709593	JR5031	1973000	GH890	2092038C00	CF5070	2249532	NA5105
1626168	JN620	1710195H	JH5056	1973100	DH890	2092100	BL650	2249533	NA5104
1626328	BN470	1711502	NA162	1973600	GJ720	2092300	BM530	2249534	NA5103
1630309	NB596	1712309	CB5660	1973700	DJ720	2092700	BF100	2443291	JD5300
1634647	NB564	1712981	EB5660	1974100	DL650	2092900	BF170	2452910	BG130
1635583	DT193	1716888	JF191	1974900	GM310	2093000	BG490	2455855	BG120
1635942	JJ334	1721547	BY560	1975000	DG052	2094600	BN570	2475762	NF761
1637279	NB572	1722734	BL680	1975100	DM530	2094700	BN580	2491400	JN244
1637280	NB596	1723843	JE555	1975400	DL650	2095000	BP900	2491900	JN245
1637281	NB655	1723875	JD071	1980600	DM530	2095100	BP910	2492500	JN245
1639237	BN150	1726016	JD315	1983000	DM710	2095500	BP890	2492700	JN596
1639420	BN470	1726617	BT690	1983700	DM530	2095800	BL650	2493900	JN596
1640200	PA349	1726623	BT680	1984000	GF583	2129717	JD281	2494300	JN292
1641037	JN815	1730217	BS320	1984500	GF583	2129717E	JD281	2494500	JN426
1641890	NF780	1730226	BL690	1984600	GF583	2243781	JD275	2494600	JN544
1641893	NA793	1730747	BP620	1984700	DF580	2243877	DR422	2494800	JN547
1643417	BL080	1734280	BP610	1985000	DM530	2243879	DR422	2495300	JN238
1643418	BL080	1736317	BX270	1985300	GG050	2244328	DW730	2495400	JN658
1644642	DT193	1736318	BX280	1985400	DG050	2244384	JD274	0002518600	NF072
1644647	HR660	1736319	BX290	1985600	DF580	2244398	JN955	0002554600	BF110
1644898	JD5268	1736340	BX300	1990500	DG052	2244568	JD276	2692037	AK300
1646401	BP900	1739545	JD608	1990600	GG052	2245426	BZ110	2696300	NB575
1646402	BP890	1739813	JJ612	2000021	HBS002	2245427	BZ120	2698233	EG851
1646403	HBS015	1739849	BZ130	2000574	HBS002	2245438	JD612	2702328	EG851
1646404	HBS015	1740437	KK5520	2024152	HBS161	2245483	BW730	2706760	DD070
1646405	HBS015	1740982	DY570	2024153	HBS161	2245484	BW740	2706794	EH445
1646406	HBS229	1741468	AC5370	2030100	BG450	2245599	JP078	2706869	DD072
1649205	BJ440	1741470	AC5380	2030200	BG170	2245686	JM5063	2706877	DK642
1651474	JN662	1743719	JD243	02030800	BH950	2245749	EY280	2706893	DK643
1651532	HR631	1900032	FE603	2069150A00	JF047	2246093	AY270	2713931	HM5293
1651564	JD028	1900507	CE602	2071101A61	JF031	2246174	JD5134	2714350	DM631
1651565	JD028	1900812	CG01A	2071101P00	JF018	2246703	EY270	2717049	JB917
1651775	JN332	1904382	NC048	2090400	BM530	2246704	CY270	2717346	HA5042
1651865	JJ456	1904915	JC055	2090600	BL650	2246944	JD5108	2717353	HA5041
1653964	JJ455	1905925	CN458	2091002B00	FG8050	2246945	JD5107	2717361	HA5040
1653965	HBS001	1905933	DR073	2091002F00	FG8060	2246996	JM5118	2755809	EH445
1657016	BT110	1907799	DR073	2091016	PA349	2247030	BZ510	2755817	EH445
1657620	JN620	1907801	DS381	2091022AC0	GY735	2247091	JR5022	2757201	HL462
1662772	ET191	1907802	DS381	2091023A10	FG8040	2247447	JM5106	2757219	HL469
1662936	BT190	1907836	AN450	2091026A01	FG6040	2247498	BZ500	2757276	EG920
1662937	BT200	1908009	DE588	2091026D00	FG8290	2247499	BZ510	2757284	DM631
1662938	BT210	1908010	FY291	2091026E00	FG8291	2247500	BZ520	2757433	HL463
1663389	JD264	1908015	DR073	2091027C00	FG7910	2247501	DZ661	2757441	HL469
1663390	HBS031	1908028	JE476	2091035	KJ647	2247511	EZ800	2757458	DL491
1663394	JN950	1908038	GP190	2091037D00	FG5690	2247591	JM5076	2757466	DM631
1663814	NB959	1958533	CC5750	2091038C01	FF5070	2247949	JH5033	2865971	JA415

OE reference	▲ Payen	OE reference	▲ Payen	OE reference	▲ Payen	OE reference	▲ Payen	OE reference	▲ Payen
2866918	BN010	3452604	BX080	4081258	KS830	4249516	JR556	4404240	HBS373
2877490	BN010	3453675	AE5040	4100576	KD226	4249520	LS492	4404512	BP060
2888120	JA499	3456314	NB469	4107391	JR154	4250500	LS496	4404985	NA5187
02961985	NF185	3461793	NB575	4109133	KV122	4256857	JM508	4405405	LT498
2995609	CB5720	3466265	NF185	4117850	JM333	4258405	JM663	4406740	BP070
0002998600	JB837	3485400	JC135	4127971	JC973	4265701	HR599	4407095	BD790
3002100	JN238	3490300	JB841	4129204	AC5780	4268806	JM508	4408006	JM5086
3006952X1	NF539	3490600	JB842	4129205	AC5790	4269036	KD747	4408201	KA354
3042600	JJ283	3490800	JB842	4129763	KT639	4271052	JC134	4411012	JC507
90003098015	KG664	3492300	JB875	4139726	JH5065	4279393	JJ100	4411018	HBS392
3100762	LT726	3493200	JB954	4145587	JM333	4279427	KL221	4411018 (16x)	HBS392
3101036	JN248	3493400	JC091	4147260	JE390	4279436	JC054	4424154	JN417
3101048	JB851	3494400	JC566	4150660	JM508	4279438	JC055	4428157	KD717
3102768	KJ647	3494600	JB869	4151277	JA757	4279457	KL221	4428391	LT023
3104301	JE648	3494700	JC423	4151468	KV122	4279599	KA546	4431654	BP110
3121867	KG5012	3494900	JC415	4152873	JE388	4279822	KA547	4432544	KD726
3130700	HC347	3495900	JC415	04153728	HR660	4287796	BP070	4434846	BP510
3210061	BE580	3501775	HR805	4158100	KT465	4291098	BP190	4434846M	BP500
3210112	BR070	3507025	JJ551	4158646	JM085	4301180	NA869	4434864	BP090
3212700	HG087	3507033	JC146	4163738	JM077	4302267	LR902	4434865	BP110
3213700	HG087	3507074	JA5042	4166914	JE388	4306719	JM674	4434903	BP050
3214136	BR070	3507309	NA5149	4174016	JH5065	4309031	JD146	4435023	BK540
3214139	BE580	3514521	BK640	4176872	KV365	4314367	KJ156	4436577	LV582
3214600	HG104	3517860	HR599	4177112	JA757	4314547	LA055	4436580	JC738
3214800	HG093	3517893	HR599	4178154	KA354	4319009	LS649	4438671	LV588
03241035	JM053	3531015	AA5620	4179038	JH494	4323710	JN283	4444408	BP110
3267244	NF634	3531016	BX650	4179084	BP070	4325201B00	NJ553	4444409	BP110
3267783	HC354	3531017	BY360	4179085	JN805	4325201G00	NJ843	4444450	BP110
3277158	NF722	3531018	BY370	4179112	JA757	4325203	NJ844	4444453	BP090
3277432	BT080	3531207	NA5138	4179113	KT758	4330005	BP190	4446715	JJ136
3277433	BH690	3531326	JE248	4179117	KT754	4331606	JH111	4446952	NB730
3285200	NF692	3547615	JC152	4179138	LR922	4336357	JB605	4448165	LT439
3287347	BH690	3547852	JC261	4179154	KA354	4351195	LA163	4448401	BP090
3287515	JN555	0003831400	BF100	4179155	KA293	4353417	JC137	4448677	JM663
3287542	NF851	0003833300	BF170	4180564	KT753	4357028	HR599	4450950	JC134
3287555	BL970	3834201	NJ688	4180964	KT639	4358946	NB732	4460810	BG830
3287710	EL960	3834203	NJ213	4181043	KT446	4364121	KA556	4461966	KS176
3287961	BL960	3834206R00	NJ658	4181044	KS830	4364122	LT021	4464012	KG393
3287962	BL980	3898547	JD5755	4181046	KV122	4369825	JD019	4464457	LT439
3310075	AF070	0003900453+E6525	CA3140	4184495	KH029	4370933	HR596	4467264	AC5780
3310671	BL390	3922601	AC5880	4192740	KA295	4379220	BP190	4467939	BP050
3310742	BR510	3940202	JC365	4192860	JH881	4379970	BD790	4467996	BJ860
3310785	BC630	3978089	JD5754	4193959	KA294	4387346	BP060	4467997	BJ870
3310865	BY340	4010395	KH007	4194060	JA777	4387608	AE600	4467998	BJ880
3314488	BP290	4022701	NJ692	4194300	BP030	4387618	BP070	4468200	BP050
3342088	BL910	4022741W01	NJ693	4195119	KT756	4387623	BP190	4468501	JA777
3342917	JH5011	4022741W02	NJ693	4195130	JM663	4388512	JM508	4469751	HBS051
3343793	JN732	4022741W03	NJ693	4196625	JE475	4390870	JM508	4469752	HBS051
3343862	BS010	4023206R00	NJ838	4197026	HR641	4391213	BP070	4469882	BP070
3343863	BS020	4023206R10	NJ838	4198159	KA292	4392929	BG820	4469883	BP110
3343864	BS030	4023233P55	NK212	4216787	BP030	4394109	JN459	4485415	NA448
3344044	DL916	4023251	NJ838	04221154	HR801	4401431	NB727	0004489200	JB836
3383442	BL910	4023251E10	NJ838	4227446	LR922	4403536	CE5210	4501060	HBS054
3397074	JD331	4028565	AC5870	4243837	OK473	4403864	EE5220	4502167	JH5052
3448125	NB691	4064640	AE600	4244285	JE475	4403866	EE5220	4502789	GX392
3448943	JN521	4081257	KT753	4249510	JJ078	4403867	AE5210	4503983	NC006

INTERCHANGE OE → PAYEN

Vergleichsliste OE → Payen • Références croisées 1ère Monte → Payen
Intercambio entre equipo original y Payen

OE reference	▲ Payen	OE reference	▲ Payen	OE reference	▲ Payen	OE reference	▲ Payen	OE reference	▲ Payen
4552600	AC5780	4770293	BY270	5010193	DJ441	5012924	DD502	5013049	JM413
04556666	JH5060	4770764	JD5204	5010956	DC240	5012925	DK480	5013050	JN410
4581198	AD5600	4773487	BY270	5010958	DC240	5012927	DM530	5013051	JN433
4585202	AD5610	4776544	JC732	5011844	DM940	5012928	DL550	5013058	JN513
4599561	KA499	4777071	AC5550	5012613	CH854	5012929	DK470	5013059	JN665
4601047	JM658	4790923	AN450	5012614	CH864	5012930	DL010	5013062	JN462
4601057	AN110	4798966AC	CC5550	5012615	DN140	5012931	DM381	5013063	JN453
4601981	JC732	4798992AB	CC5603	5012778	DN470	5012932	DK610	5013064	JN344
4602067	JH901	4804952	JD5867	5012787	DF351	5012933	DK611	5013065	JN434
4607627	KV927	4816877	KH029	5012796	DN170	5012936	DM840	5013068	JN533
4608942	KA499	4828150	HBS011	5012798	CJ051	5012942	DJ852	5013070	JN562
4610742	JE476	4830224	HR602	5012802	CX660	5012947	DG811	5013071	JN576
04621939AB	NA5140	4830381	AN370	5012803	DD955	5012951	CF070	5013073	JM261
4632246	JB926	4832015	BP270	5012804	DD955	5012952	CF073	5013076	JM053
4634127	BD070	4832204	BP270	5012808	DD010	5012953	CF473	5013077	JN396
004634596	BY380	4834948	JF123	5012812	DC929	5012954	CF474	5013078	JM019
4635876	JJ065	4837051	AB5100	5012814	DP060	5012957	CK262	5013080	JN410
4636982AC	CC5611	4837141	JC055	5012818	DF351	5012967	DC993	5013081	HL474
4638466	JB917	4837300	KV927	5012819	DH681	5012968	CH865	5013165	BN080
4639993	JN279	4837311	FY291	5012820	DM530	5012969	DC240	5013166	BN090
4653848	AN450	4837347	DS381	5012830	DL570	5012977	JN279	5013167	BN100
4653849	AN450	4837349	DS381	5012831	DH860	5012978	JM005	5013178	BG820
4659145	AN370	4844484	KA546	5012832	DD630	5012979	JM044	5013179	BG830
4661307	KA350	4846584	JR580	5012839	DM710	5012980	JM077	5013180	BL010
4667156	NF886	4846873	AN450	5012840	DP070	5012984	JM023	5013181	BL020
4670516	AN370	4848253	BP270	5012842	CK663	5012985	JM023	5013182	BL030
4673810	LR948	4848254	BR090	5012844	CJ051	5012990	JN596	5013293	DN150
4680722	AN370	4851921	JC732	5012847	DP190	5012994	JN283	5013294	CH864
4686359	KV365	4851923	KV927	5012850	DC790	5012995	JN297	5013627AA	AC5570
4690375	AN450	4854648	HBS011	5012851	DC800	5012996	JM085	5013820	EH752
4694216	AC5580	4862154	NF886	5012853	DG871	5012998	JN251	5013872AA	CC5561
4694216B	AC5580	4868476	AN370	5012854	DD501	5012999	JM333	5014127AC	AC5550
4694217	AC5590	0004886400	BF170	5012859	DN170	5013000	JM315	5014173AC	AC5560
4694217B	AC5590	4891275	BP510	5012864	DD621	5013001	JN244	5014257	DL402
4696011	JN911	4897383AA	JD5876	5012866	DD955	5013002	JN248	5016204	DP790
4697094	AN350	4988551	JM658	5012867	DH870	5013007	JN238	5016206	DJ442
4699065	AN110	5000812	CH851	5012869	DC92B	5013009	JM663	5016208	DJ441
4704466	LS858	5002397	DC240	5012870	DC935	5013010	JM986	5016718	GT510
4706862	LS859	5002398	HC355	5012871	DP011	5013012	JN232	5016720	DT510
4710881	JR580	5002648	HC418	5012875	DD955	5013013	JM848	5016758	BF580
4716458	NP067	5003750	GF583	5012877	DP110	5013018	JM669	5016759	BP890
4716750	NP068	5003751	HC347	5012878	DJ420	5013019	JN273	5016760	BP900
4720740	EG9690	5003752	DF580	5012879	DJ430	5013020	JM302	5016761	BP890
4722674	LS856	5004823	HC418	5012882	DD631	5013021	JM025	5016762	BP900
4722675	LS857	5004856	DC240	5012887	CJ127	5013022	JM008	5017826AB	CC5560
4731124	BE580	5004857	DC240	5012890	DN010	5013025	JN068	05017826AC	CC5562
4732165	LS856	5006391	DJ440	5012891	DN041	5013028	JN317	05019801B	CY942
4732166	LS857	5006392	DJ440	5012894	DK020	5013030	JN365	5020122	EX480
4738019	JN462	5006393	HC440	5012895	DK020	5013031	JN292	5020123	DX480
4740008AC	CC5613	5007739	DL081	5012900	DH693	5013032	JN285	5020272	GT510
4741124	BE580	5010033	GG050	5012901	DH683	5013033	JN454	5020274	DT510
4741822	BE580	5010034	GH890	5012904	DK640	5013034	JN356	5020402	DN471
4741963	CG9690	5010035	HC346	5012905	DL340	5013037	JN299	5020844	DT110
4763355	JH5065	5010036	DG050	5012909	DK441	5013038	JN300	5020866	DT482
4766646	AN370	5010037	DH890	5012913	DF871	5013044	JN459	5023360	DJ444
4770290	BY270	5010173	DL401	5012923	DK440	5013046	JN496	5023478	DG050

OE reference	▲ Payen	OE reference	▲ Payen	OE reference	▲ Payen	OE reference	▲ Payen	OE reference	▲ Payen
5026563	DC240	5452930	JB869	5607815	JM5198	5880661	DP070	5882343	HC027
5026592	JB799	5452930D	JB869	5607816	AE5520	5880662	GP070	5882358	GV680
5026593	BC240	5463048	GF051	5607817	AE5530	5880771	GP060	5882461	DP688
5027040	CH865	5463048G	GF051	5607818	AE5540	5880773	DP060	5882462	GP689
5027041	CH864	5469955	HR340	5607820	AG9780	5880858	GD671	5882567	DP660
5027042	HC285	5475299V	BF580	5607821	AG9820	5880860	DD790	5882568	GP660
5028398	EG340	5487062	GF492	5607822	AG9770	5880948	BD790	5882634	DR100
5028399	DT110	5491223	JB833	5607837	AH5030	5880957	GD790	5882669	GP861
5028400	DC240	5491225	JB864	5607838	AE5950	5880958	DD790	5882674	DP860
5028414	DW630	5491733	BF600	5607839	AD5800	5881122	DP110	5882781	GP871
5028415	DW631	5493122	BF600	5607840	AD5810	5881135	GP070	5882782	DP871
5028416	EW630	5493998	BG450	5607841	AD5820	5881137	DP070	5882784	DP870
5028466	EH850	5494183	BG540	5607842	JM5259	5881157	DP133	5882840	DT412
5028467	CH851	5500449	JN234	5607843	AG7390	5881172	DP051	5882900	GR590
5028468	CH864	5513004	BF600	5607845	AG7400	5881187	GG811	5888178	DR480
5028469	CH865	5513006	BG450	5607847	AG7440	5881189	DG811	5888179	GR480
5028483	EA440	5514849	DT013	5607863	AE5930	5881251	HJ274	5888217	GP282
5028484	EA441	5542219	BG540	5607864	AE5920	5881252	HJ279	5888241	DP014
5028485	DP790	5546438	GG541	5607872	AE5520	5881256	HJ271	5888261	GR620
5028487	DJ441	5549420	JN251	5607937	HBS252	5881360	DJ872	5888262	DR620
5028550	EX550	5569124	GG541	5850075	JD5737	5881505	GP060	5888265	GP301
5028552	DX550	5606427	BY250	5850607	JD457	5881506	DP060	5888266	DP301
5028553	DX550	5606449	BY250	5850609	JD5269	5881529	DP133	5888318	GR630
5028555	DY640	5607058	AB5140	5850611	JD5229	5881645	GP070	5888319	DR630
5028583	ET490	5607405	JN955	5850612	JD445	5881647	DP070	5888361	GT370
5028584	DT500	5607406	BZ110	5850613	JD444	5881650	DP110	5888447	DP292
5028596	JC364	5607407	BZ120	5850614	JD276	5881652	DJ851	5888471	DT412
5028781	BW010	5607408	BP800	5850615	JD445	5881692	GR590	5888493	DP68A
5028782	BW020	5607409	BY250	5850616	JC437	5881821	HJ274	5888526	DP689
5028783	BW030	5607410	AY210	5850621	JD5914	5881903	GR541	5888534	GT300
5031032	EW630	5607422	AB5671	5850623	JD5256	5881904	DK541	5888535	DT300
05066786AA	JM7049	5607423	AB5681	5850624	JD5149	5881910	GR541	5888591	DT370
05080084AA	JM7028	5607425	BS260	5850637	JC824	5881912	GR541	5888632	DV680
05083152AA	CC5720	5607430	AY410	5850638	JD5347	5881915	DK541	5888634	DT290
05093904AA	JD5875	5607431	AY420	5850644	JD5300	5881923	DR073	5888652	BP520
5120058	JM5028	5607432	AY160	5850649	JD5868	5881944	GG811	5888653	BP510
5142000	NF634	5607433	AY170	5850653	JD5869	5881945	DG811	5888654	BP060
5142900	NF692	5607434	AY180	5850667	JD5400	5881970	GJ852	5888656	BP070
05166481AA	AG9660	5607435	AY900	5850671	JD5336	5881971	DJ852	5888657	BP110
05166482AA	AG9670	5607436	AY910	5850672	JD5333	5882008	HJ277	5888661	BK540
05166483AA	AG9680	5607437	AY920	5850673	JD5412	5882026	GR590	5888664	BP190
5212152	KS176	5607438	AB5010	5850674	JD5411	5882029	DP022	5888681	FB5100
5255420	FG210	5607439	AB5020	5850796	JD5904	5882032	GR130	5888683	GP301
5364179	JR749	5607440	AB5030	5850858	JD5223	5882038	GP051	5888684	DP301
5403212	HR340	5607442	JM5159	5850862	JD5196	5882039	DP051	5888838	FB5100
5412007	HR340	5607443	AY160	5854981	JE5065	5882040	GP051	5888940	HJ282
5412579F	JN234	5607444	AY170	5854987	JE5066	5882041	DP051	5888941	HJ283
5414228	JB868	5607445	AY180	5858607	JD457	5882049	DV680	5888961	GT444
5414228E	JB868	5607448	AB5240	5880410	FE603	5882059	GP060	5888989	DT410
5414244	JR529	5607451	HBS419	5880411	CE602	5882060	DP060	5888992	GT410
5414635	KA500	5607459	AG5090	5880415	DP014	5882086	HJ280	5889087	GT400
5422857	KA501	5607463	AE5920	5880416	GP011	5882202	DP68A	5889117	GT423
5434181	JE651	5607467	JM5071	5880417	DP011	5882216	GP688	5889118	DT423
5440081R	GF492	5607474	AG9580	5880444	GP190	5882265	DR610	5889160	DT420
5443478	BF600	5607593	JM5235	5880632	FE603	5882305	HJ279	5889162	DT413
5450155R	JN253	5607814	AG9590	5880639	CG01A	5882328	DT413	5889163	DP688

INTERCHANGE OE → PAYEN

Vergleichsliste OE → Payen • Références croisées 1ère Monte → Payen
Intercambio entre equipo original y Payen

OE reference	▲ Payen	OE reference	▲ Payen	OE reference	▲ Payen	OE reference	▲ Payen	OE reference	▲ Payen
5889164	GP689	5890658	GT446	5891265	LA163	5891839	DP292	5891943	DG811
5889165	DT411	5890660	DP68A	5891271	BP070	5891840	GP051	5891945	DV680
5889166	GT411	5890662	DP68A	5891273	BP190	5891841	GP051	5891949	DP051
5889170	DT412	5890664	DT446	5891275	BP510	5891843	GP060	5891950	DP051
5889171	DP68A	5890665	GT446	5891276	BP090	5891844	DP060	5891952	GP688
5889173	DP68A	5890670	DT446	5891277	BP050	5891850	DT290	5891953	DT413
5889175	DP689	5890671	GT446	5891279	BP110	5891854	DR610	5891955	DP292
5889180	DT420	5890672	GT423	5891282	BE580	5891857	DP688	5891956	GP293
5889186	DP273	5890673	DT423	5891284	BR090	5891858	GP689	5891957	DT420
5889190	GR611	5890674	DT446	5891285	BP270	5891859	DP660	5891966	DT412
5889191	DR611	5890676	DT413	5891287	BD790	5891860	GP660	5891968	GP301
5889193	DS570	5890678	DT420	5891289	BP290	5891862	DR100	5891969	FB5100
5889194	GR611	5890681	GT446	5891290	BK540	5891863	GT370	5891972	DE588
5889195	DR611	5890683	DT441	5891292	BP060	5891864	DP860	5891973	DT411
5890228	DT441	5890684	DT441	5891293	BP060	5891866	GP680	5891974	GT411
5890229	GT441	5890685	GT441	5891297	BG820	5891871	GP871	5891977	DT412
5890312	DT440	5890690	DT410	5891298	BG830	5891872	DP870	5891978	DP68A
5890323	GT410	5890691	GT410	5891300	BR070	5891875	DP014	5891980	GT410
5890455	DT446	5890692	DT440	5891301	BP270	5891879	DP292	5891981	DP689
5890456	GT446	5890693	GT446	5891302	BR090	5891881	GT300	5891983	DP689
5890457	DT446	5890694	GV680	5891303	BP520	5891882	DT300	5891985	DP68A
5890458	GT446	5890695	DV680	5891307	BT420	5891890	GT444	5891986	DP68A
5890459	GT440	5890696	GV680	5891308	BT410	5891893	DT420	5891987	DT413
5890461	GT446	5890699	DT290	5891321	JE480	5891895	DP688	5891989	DT410
5890467	DT446	5890703	GV680	5891342	GR611	5891896	GP689	5891990	GT410
5890468	GT446	5890704	DV680	5891343	DR611	5891902	GR611	5891992	GP301
5890469	DT446	5890739	DS381	5891633	DR480	5891903	DR611	5891993	DP301
5890470	GT446	5890764	GP282	5891634	GR480	5891905	DS570	5892007	DT440
5890471	DT446	5890808	GT750	5891657	GT260	5891906	GR611	5892008	GT446
5890473	DT446	5890825	DP292	5891658	DT260	5891907	DR611	5892009	DT440
5890474	GT446	5890851	DT446	5891780	BP520	5891909	GT440	5892010	GT446
5890475	DT446	5890981	DT270	5891781	BP030	5891910	DT440	5892011	DT440
5890476	GT446	5890982	GT270	5891791	BD790	5891911	GT446	5892012	GT446
5890480	DT446	5891197	JM508	5891795	GP011	5891912	DT446	5892013	DT440
5890481	GT446	5891198	JN947	5891796	DP011	5891913	GT446	5892014	GT446
5890483	GT446	5891199	JN644	5891798	GR480	5891914	GP293	5892015	DT446
5890523	GP293	5891200	LB414	5891800	GP190	5891915	DP293	5892016	GT446
5890524	DP293	5891201	JN645	5891801	GK590	5891916	GT446	5892341	DT440
5890584	DT440	5891203	JN568	5891802	GP060	5891917	DT445	5892342	GT446
5890585	GT446	5891205	JA752	5891804	GD790	5891918	GT445	5892343	GT423
5890586	DT446	5891206	JE480	5891806	GD671	5891921	DP190	5892344	DT423
5890587	GT446	5891207	JE390	5891810	GP070	5891924	DP292	5892345	DT446
5890637	DT445	5891208	JE388	5891811	DP070	5891927	DD790	5892347	DT420
5890640	GP282	5891209	JB605	5891812	DP133	5891928	DP190	5892349	DT446
5890642	GP282	5891210	JC137	5891814	DP070	5891929	DD790	5892350	GT446
5890643	GT400	5891212	JC134	5891818	GK590	5891930	DP293	5892351	GT441
5890645	GR620	5891213	JD146	5891819	DR480	5891931	GG811	5892352	DT441
5890646	DR620	5891214	JA777	5891822	DP060	5891933	DG811	5892353	DT441
5890647	GP301	5891215	JA777	5891825	GT270	5891934	DJ872	5892354	GT441
5890648	DP301	5891216	JC693	5891827	DE588	5891935	DP293	5892364	GP070
5890649	GR630	5891220	JD021	5891828	GJ852	5891936	DP051	5892365	DP070
5890650	DR630	5891227	KL221	5891829	DJ852	5891937	DJ851	5892367	GJ852
5890651	GP861	5891228	LA055	5891831	GK590	5891938	GK541	5892368	DJ852
5890653	DP689	5891230	KS176	5891832	GP022	5891939	DK541	5892369	DP660
5890655	DP689	5891241	KD747	5891833	DP022	5891940	DT420	5892370	GP660
5890657	DT446	5891244	LS649	5891837	DR130	5891942	GG811	5892371	DP860

OE reference	▲ Payen	OE reference	▲ Payen	OE reference	▲ Payen	OE reference	▲ Payen	OE reference	▲ Payen
5892374	DP871	5892690	DW260	5895645	GX041	5999294	LB025	6123006	BM950
5892376	GP282	5893002	DT440	5895663	DX030	5999321	JE187	6123007	BM960
5892377	DT400	5893003	GT440	5895664	GX030	6008688	HR632	6123008	BM960
5892378	GR630	5893004	DT446	5921087	BP290	6033901	BC240	6123009	BM980
5892379	DR630	5893005	GT446	5928264	BP060	6034305	NB564	6123010	BM980
5892380	GP861	5893006	DT445	5930415	HR596	6035115	JN105	6123011	BM980
5892381	DP861	5893177	DP292	5932825	LV583	6035121	JB862	6123012	BM980
5892382	GP282	5893281	GR632	5936189	BK540	6035514	HBS438	6130580	EN260
5892385	GP011	5893282	DR632	5943565	BK540	6035515	HBS438	6131024	BC240
5892386	DP011	5893329	DT440	5945253	JN426	6035516	HBS438	6131025	BC240
5892389	GD790	5893330	GT440	5949822	OK627	6036603	JC364	6132755	JN332
5892390	GP190	5893400	DT441	5950597	HR5094	6039100	HR633	6132943	BJ440
5892391	GD790	5893401	GT448	5950662	AG9770	6040689	BC240	6132957	JN620
5892394	GP022	5893560	GT442	5950670	AG9780	6043068	JB811	6134416	JJ458
5892395	DP022	5893576	GW301	5950704	AG9810	6043069	JB812	6134622	JE719
5892397	GP051	5893577	DW301	5950712	AG9820	6043882	NB596	6134623	JE719
5892398	GP051	5893658	GP285	5951664	BP290	6046336	NB572	6135090	NB785
5892400	DR610	5893660	GV670	5951675	BK540	6050313	NA5065	6135093	NB786
5892402	DP014	5893662	GV671	5951683	BJ850	6056269	NB453	6136076	BJ440
5892404	DS570	5893692	GT401	5951859	BP060	6058294	AH850	6136909	BJ440
5892405	GR611	5893693	DT401	5952256	BK540	6060903	BJ200	6137531	JE719
5892406	DR611	5893767	DT441	5953970	BJ850	6065962	JE719	6137857	JC363
5892407	GT260	5893768	GT447	5955570	HR5072	6066331	NB645	6139049	NA576
5892408	DT260	5893773	DT441	5955635	LA163	6066335	NB847	6140090	JJ348
5892409	GT400	5893774	GT441	5955636	LA163	6068982	NB655	6140310	BN140
5892410	GR620	5893776	GT442	5956115	FG9770	6073070	KT738	6140740	BL400
5892411	DR620	5893811	JC723	5959226	JJ298	6077617	DW301	6140741	BL410
5892412	GP871	5893816	JN426	5960083	AE5060	6078447	BL080	6141655	JC364
5892413	GR611	5893819	KD726	5960488	LS488	6078448	BL080	6141810	JJ334
5892414	DR611	5893843	HJ291	5960717	LV585	6078807	JM510	6141835	BM950
5892415	GT270	5893844	HJ292	5960967	BP060	6078809	NB645	6141836	BM950
5892416	DT270	5894256	GR631	5960968	BP060	6078810	NB847	6141837	BM960
5892419	DT290	5894257	DR630	5960970	LS859	6078814	JC829	6141838	BM980
5892420	GT300	5894379	DM533	5962711	AC5140	6079676	JC365	6141839	BM980
5892421	DT300	5894502	GP294	5962712	BT230	6079678	JC364	6143745	JC790
5892422	GV680	5894503	DP294	5962713	BT240	6079681	JC363	6144784	JJ334
5892423	DV680	5894574	BP270	5962714	AC5140	6081461	JN332	6145436	JE5020
5892424	GV680	5894575	BR090	5962715	BT230	6086277	AX270	6147047	HR660
5892427	DT290	5894789	DS381	5962716	BT240	6086278	AX270	6147502	BN150
5892430	GT750	5894834	KA845	5966008	JN645	6087166	BJ440	6147503	AH860
5892431	DP273	5894837	DW320	5966011	JC661	6087639	KA606	6148286	AH860
5892434	DE588	5894838	GW321	5969318	LV586	6088343	BJ440	6153084	JN616
5892435	GT750	5894853	DW330	5970285	BP280	6088344	HBS001	6154455	JM510
5892436	DP273	5894974	BV940	5972336	JA777	6090129	AH860	6154456	JN620
5892437	GT750	5895002	GW341	5973718	LV695	6092063	AH850	6155561	BT520
5892438	DP273	5895003	DW340	5980056	JN568	6093964	HBS008	6155565	BT510
5892439	GR100	5895155	DW710	5984010	BT410	6094666	JN460	6155577	JN662
5892440	DR100	5895156	GW711	5984039	BP280	6104534	JM875	6155579	NA5177
5892441	GJ872	5895243	DW720	5984080	JR673	6107900	BL340	6156076	DJ440
5892445	DT370	5895244	GW724	5984091	BG820	6107901	BJ440	6157016	DT110
5892454	KD717	5895398	DW281	5984092	BG830	6112201	NB788	6159538	BP890
5892672	DT441	5895399	GW281	5994226	JN667	6121888	JC565	6159539	BP900
5892673	GT441	5895505	GR632	5996707	JC693	6121889	JE5022	6159540	BP890
5892678	DT752	5895540	DT448	5997192	LV589	6123003	BM950	6159541	BP900
5892679	GT750	5895541	GT448	5997543	BP300	6123004	BM950	6159984	BN150
5892689	GW260	5895644	DX040	5999103	BP290	6123005	BM950	6163883	HR661

INTERCHANGE OE → PAYEN

Vergleichsliste OE → Payen • Références croisées 1ère Monte → Payen
Intercambio entre equipo original y Payen

OE reference	▲ Payen	OE reference	▲ Payen	OE reference	▲ Payen	OE reference	▲ Payen	OE reference	▲ Payen
6165295	JR265	6498578	JJ457	6850672	JD5333	7506983	AC5310	7571344	HR5030
6165498	NA5177	6503561	HBS391	6851355	JD498	7508543	AC5920	7574959	BT860
6165499	NB645	6503561 (4x)	HBS391	6909665	JA770	7508545	CC5920	7574967	JN643
6165500	NB645	6503562	HBS391	6918548	BY740	7509710	AC5440	7575382	JN928
6165502	NB847	6503562 (6x)	HBS391	6918549	BJ440	7510241	JO800	7575386	JD153
6166108	JJ348	6505528AA	HBS439	6930966	JD554	7511535	CC5440	7575665	BP860
6166499	HBS032	6506785AA	HBS439	7008824	JJ531	7514946	JO800	7576051	BP870
6166533	HR655	6518302	BT800	7024740	HM5238	7516529	BT560	7579741	BP280
6167440	BC240	6523435	HR661	7029357	BK540	7518343	HBS179	7579742	BP280
6169448	JD240	6526341	AB5800	7048712	NB984	7518996	JD348	7580221	BP860
6172130	JD542	6526342	AB5810	7079275	HBS031	7521859	BK610	7580547	JJ366
6173218	DT800	6526343	AB5820	7087348	BT480	7522709	KG664	7581344	HR599
6173339	JD009	6531620	BT480	7087349	BY640	7530606	JD5909	7581743	HBS052
6173340	HA497	6535949	HR631	7104290	NA5175	7533476	BP520	7582158	HR599
6174264	AH860	6558046	HBS032	7114447	BW650	7533479	BP520	7582245	HM5278
6175355	BT190	6581669	BY640	7116165	AC5910	7533622	NB825	7585037	BK610
6175356	BT200	6591016	JC790	7116166	BX550	7537664	JC660	7585045	BT560
6175915	NB984	6591017	JC829	7126483	JD545	7537684	BP660	7588550	BP870
6176006	BP910	6608692	JA769	7156008AAB	FX270	7539929	BP030	7588905	JC694
6176471	NB645	6614762	NA576	7157744	JM413	7540289	BT420	7588940	JC305
6176472	NB847	6656422	HBS006	7181761	JE5021	7540290	BP290	7589509	JR749
6176727	BT140	6663814	NB645	7187587	HC059	7540379	BT440	7589788	BP110
6176775	BT140	6669767	JD265	7199261	NA567	7540797	JD5428	7590224	JC692
6178334	JD188	6674302	HR661	7199290	NA567	7541092	JN587	7596552	BT400
6179100	BT210	6678475	BT480	7204021	JM550	7541250	BT860	7596614	JN667
6179489	NC044	6678476	BT480	7206398	JA608	7541251	JN666	7596714	JC738
6179653	JD543	6689713	ET800	7206399	JA609	7541252	JC723	7596968	BP660
6180424	JD309	6689714	ET800	7300041	KA292	7541776	BJ860	7597077	JD019
6180425	JD310	6689715	DT800	7300265	KA547	7541777	BJ870	7597553	BT300
6180638	JN817	6689716	DT801	7300766	JJ214	7541778	BJ880	7597555	BT320
6182700	KS696	6707924	HC355	7300877	JC055	7545947	BP280	7597832	JN809
6182957	NB856	6707927	HC452	7300904	KA292	7546474	JC692	7604264	BT420
6182959	NB855	6718225	JE248	7301198	NP067	7546875	JN644	7604403	BR620
6182960	NB854	6740296	JD310	7301262	NP068	7546876	JN644	7604404	BR630
6184406	HBS050	6751295	JD065	7301481	JN462	7546877	JN644	7604488	KA5032
6185177	BT520	6755720	BW630	7301683	JJ100	7547337	LT019	7609752	JC738
6185178	BT520	6763409	JA769	7302293	JN594	7548921	CG9540	7610498	JD013
6185181	BT510	6765358	JN816	7302473	BR070	7552453	LA378	7611006	JR749
6185182	BT510	6772501	BY750	7302582	JJ317	7552551	BT410	7612425	JN645
6185881	JN816	6772502	BJ440	7302624	JN585	7552552	BT420	7613726	HR5064
6188592	JC724	6780895	JD264	7302800	BP270	7553021	BR110	7616679	BT860
6189298	BT110	6782777	BW650	7303076	JC706	7553022	BR120	7621070	JD022
6190948	NC044	6812072	BP890	7303077	JC706	7553561	NB815	7621071	JD022
6191988	JJ457	6812073	BP900	7303161	DR073	7553616	HR599	7622909	NA5059
6192141	BT480	6812074	BP910	7303168	BP270	7553636	HR596	7624874	BR680
6193087	JJ484	6816643	AH860	7303362	BP270	7553637	HR805	7624875	BR690
6193676	JD066	6838365	KA289	7303596	BR090	7554279	NB815	7624876	BR700
6195424	JJ458	6842093	NA869	7334619	HM5236	7554363	JJ453	7625272	JD021
6198560	AH860	6842160	NA869	7334619 / 959M 6584 AA	HM5236	7554851	JP049	7625273	JD021
6201251	JM5027	6842272	NA5138	7402415	CA5431	7554963	JJ471	7625500	BT410
6306910	DF106	6842273	NA5018	7484405	BT560	7555140	BR620	7625504	JC662
6461884	BW350	6842274	NA5017	7500713	HR599	7555756	AG9550	7625508	JR749
6474024	BT190	6842347	HBS178	7500716	HR816	7564332	BR630	7625749	OK473
6474025	BT200	6842347-4	HBS426	7501304	AC5900	7564650	BT220	7627225	JC692
6474026	BT210	6847748	BW640	7502346	JE5012	7564651	BR690	7627547	JC661
6491460	JN620	6847749	BW630	7505217	BK610	7564652	BT240	7628414	JD013

OE reference	▲ Payen	OE reference	▲ Payen	OE reference	▲ Payen	OE reference	▲ Payen	OE reference	▲ Payen
7628850	NA5070	7684064	JN948	7735415	JA5036	7770027	KA292	8096764	BE580
7630180	BR680	7688249	BP520	7736289	BW340	7770028	KA294	8096780	AY300
7630181	BR690	7688450	JN667	7736290	BW350	7772358	JD226	8096910	BX410
7630182	BR700	7692408	LV582	7736291	BW360	7772495	JD146	8096911	AV590
7631023	BP520	7694363	BT260	7737202	LR902	7773831	JN973	8096930	DX391
7631024	BP030	7694624	BT260	7737204	KT756	7774233	KL477	8097064	AY290
7636480	JD022	7695569	LV585	7737607	JP019	7775802	JD227	8097066	AY310
7637103	BP860	7696197	HBS052	7737757	KT600	7775920	HBS227	8097075	BX420
7638954	JC662	7698712	JD019	7737758	JR154	7776753	BR110	8097366	LC280
7640074	BP300	7700490	BR680	7738383	JM654	7777153	BP280	8097421	CY680
7640783	BP660	7700491	BR690	7738687	JN643	7777226	JJ605	8112180	BP660
7640784	BP280	7700492	BR700	7739776	KT758	7778043	KK5507	8314502	JJ080
7641615	BR110	7700579	JD153	7741845	JN417	7779904	BW340	8338782	JJ080
7641616	BJ860	7700581	JD153	7742042	JC973	7779905	BW350	8348161	BC650
7644534	BR620	7701853	JN643	7742045	KD226	7779906	BW360	8358780	BC650
7645030	BJ850	7702131	LV585	7742046	KT446	7782288	BJ860	8361842	JC305
7645031	BP870	7702766	LT019	7742758	BT300	7784728	JM654	8365835	JN285
7646223	JD148	7702768	LT498	7742760	BT320	7785234	JC694	8528623	JB851
7646248	JJ413	7702769	LV589	7744000	BX040	7785352	BR110	8642629	AG8340
7647596	JJ398	7702770	LT021	7744134	LB177	7785805	BR680	8653739	NA5191
7648057	BV670	7702772	LV583	7745836	BP520	7785806	BR690	8658619	AF5330
7648248	BP520	7702773	LV582	7745837	BP520	7785807	BT240	8658620	AF5320
7648249	BP520	7702774	JN459	7748504	JS081	7787262	LK5007	8658621	AF5310
7648250	HBS109	7702873	BP290	7748505	LB175	7787630	JD5183	8675251	AE5150
7648251	HBS109	7702874	LS492	7749148	BT240	7788072	CC5410	8787111	AC5690
7649849	JJ449	7702979	KT465	7749709	JC660	7788636	AC5300	8801466	JC365
7650355	HR599	7702980	KT754	7750404	NF888	7788640	AB5990	8810400	KG664
7650612	HBS097	7702981	KV122	7750406	BX040	7788641	BJ870	8811101	NB564
7651738	LB414	7703134	JC661	7751688	BT860	7788642	AB5980	8812067	HR633
7651739	JN644	7706068	HR800	7752460	BT260	7788651	AE5340	8815326	NA162
7653650	HBS095	7706480	JF145	7755739	KT753	7788652	AE5350	8818254	HM5070
7656128	JN645	7707675	JD019	7755740	KS830	7788656	AE5360	8819112	JC305
7657305	JN804	7708317	JN934	7755741	KT446	7788657	AE5370	8819831	DT561
7659102	BV680	7708513	BT400	7755742	JD067	7789503	BJ880	8822041	HM5070
7659103	BV690	7708514	JD022	7755744	JJ471	7789977	AC5410	8841598	JA609
7659104	BV700	7709257	BT410	7756836	KT754	7789978	AC5420	8849920	JM550
7659618	JD151	7709259	JA757	7758731	HBS131	7789979	AC5430	8930216	JC155
7660565	JN643	7709435	BT400	7759146	BR680	7790052	AC5410	8960714	BN040
7660759	JN803	7709658	JP049	7759147	BT230	7790053	AC5420	8961071	NB575
7660966	BT440	7709714	HR800	7759148	BT240	7790054	AC5430	08966202	JN956
7662197	BT410	7709978	LT439	7759873	JC152	7792168	BT300	8981424	BN040
7663366	JJ453	7710013	JM654	7761598	JD225	7792170	BT320	8981425	BN040
7665093	JD067	7710162	HBS092	7764415	KA295	7794462	JN568	8981725	BK020
7665789	BR110	7710582	HBS132	7765224	JD013	7794495	JM5167	8981931	JN041
7666858	BR620	7711030	JD198	7765227	JD225	7795992	HBS247	8983127	HC417
7667675	BR630	7715139	JD151	7765454	JC738	7797034	JP049	9000269	GF051
7668195	JD151	7715492	HL701	7766037	JD150	8012426	BJ850	9000269U	GF051
7668658	LV585	7715789	JN819	7766203	BW330	8035260	BP820	9000340U	GF492
7669581	JF145	7716337	HCO27	7766236	JN933	8054130	BL390	9003805	NB775
7669585	JJ440	7719718	BT300	7766268	BW320	8070900	NF778	9032853	JN626
7672168	BT410	7719720	BT320	7766412	JN928	8096371	JC707	9059169	HR363
7676324	JN948	7721482	LV695	7766959	JR673	8096541	AV690	9059172	HR662
7677631	JC738	7724059	BR630	7768026	JN972	8096619	JR580	9063193	HR791
7678282	JF150	7724244	JD148	7770023	KA293	8096620	LS858	9064457	HR280
7679380	BP870	7724489	KT465	7770025	LA378	8096682	JC055	9064460	ET681
7681451	NA5060	7724665	NA5061	7770026	KA354	8096748	BR070	9065438	HR817

INTERCHANGE OE → PAYEN

Vergleichsliste OE → Payen • Références croisées 1ère Monte → Payen
Intercambio entre equipo original y Payen

OE reference	▲ Payen	OE reference	▲ Payen	OE reference	▲ Payen	OE reference	▲ Payen	OE reference	▲ Payen
9065439	DY541	9194643	EC101	9942588	JP069	13177720	HR599	20691510	JF079
9065638	BC940	09194750	KG5337	9944352	DS381	0013195100	NF692	20920023A00	DY710
9065657	BC930	09194778	CG9580	9955635	LA163	0013236800	JB836	21091000	HG108
9066452	DR831	9196318	CB5141	9961879	CK302	13238800	BF170	21091100	LV847
9066462	EW730	9196320	CE5920	0009970747	NF539	13262399	HBS175	021103383L	AA5430
9066503	JJ536	9196358	EB5360	10280060	KG664	13266408	JN279	021103384D	HBS077
9067655	JJ614	9196359	CB5360	10298460	KJ779	13280177	BW680	021103384DEF	HBS077
9070058	DW731	9201669	AG9570	10901146	NA448	13280185	BW690	021103384DS	HBS077
9070530	HL734	9225834	JE5017	11011030	DR630	13280193	BW700	021103384E	HBS077
9070531	HL735	9225835	JE5024	11023580	KG664	13326442	BK640	021103384F	HBS077
9070532	HL736	9226543	JD5277	11023582	KG664	13367537	JN635	021103384G	HBS461
9070615	DZ130	9230949	JD5868	11057052	NB792	0013516400	DL611	021103384K	HBS461
9070622	DZ121	09240105	AY170	11082802	HBS002	0013516600	GL610	021103384L	HBS461
9070982	HR5045	09275497	JN068	11121726	HBS041	0013627500	BL610	021103483B	JM5030
9102229	NB684	9275816	JN521	11405062	NB564	13782172	JB917	021103483D	JM5099
9106027	AY210	9281324	NB628	11405468	JM875	13782180	JE248	021103609	JH5013
9106235	BY240	9292234	NB690	11405576	NB564	13784756	BX090	021103609B	JH5059
9106305	AY220	09292549	BH860	11406307	JC365	13786454	BD070	021105245B	NB953
9117667	CB5241	9292550	BH860	11432207	HC060	13786462	BK640	021133227C	JD5232
9117670	DY232	09293311	BH860	11448543	NB564	13788526	JD346	021133227H	JA5068
9117671	CY211	9295029	JN523	11490525	HR630	13788542	JD345	021133227J	JD5232
9117672	CC5460	9305970	JN285	11543491	JM875	13788641	JD665	021198011A	EC340
9117674	EB5240	9306911	JN513	11546325	HC418	13788708	JN635	021198012A	CA5430
9118348	DY300	9307281	BK610	11599609	JM875	13788799	JB926	021253039C	JA5069
9118351	CY210	9309204	NB714	11612777	HR397	13789094	JN279	021253039E	JA5069
9118642	EK486	9311077	JC365	12015120	NP068	13971330	HBS052	021253050	JD5109
9119303	AB5540	9321464	HM5070	12032063	DK570	13977272	AA5630	021253050B	JD5109
9119304	AB5360	9321605	DT562	12060700	KA606	13977285	AY260	22022072F	AY400
09119338	BY270	9337239	DK610	12061300	KA525	0014875400	BF170	22022073F	AY410
9120660	EB5671	9337247	DK611	12062300	KA606	11600015080001	BC370	22022074F	AY420
9126277	JD5210	9337254	DK612	12180279	NF634	10500015080301	AF370	22022078F	JD5144
09129038	BY250	9350281	BK610	90012300625	KJ779	11900015080801	BW310	22022080F	AY400
09129105	BY270	9355991	JN513	12571139	NB716	11900015130801	BW300	22022081F	AY410
9129716	JD5148	9404725	AB5420	12571741	JC152	16744200	NF694	22022082F	AY420
9129909	HBS180	9404726	AB5450	12572210	NA5001	0016877200	BF170	22022090F	BZ630
9135513	BY370	9404727	AE5160	12572574	BG940	17065804	HR599	22022091F	BZ640
9135894	HL728	9440651	NA5178	12589366	JD5867	17067073	HR599	22022092F	BZ650
9146007	BW680	9443310	NA5136	12667135	JE248	17100900	JE647	22030362A	JN581
9146008	BW690	9443787	HR5076	12667960	JC440	17103200	JE145	22032114F	JD025
9146009	BW700	9443895	AB5430	12667961	JC440	17104500	JE189	22032145H	JN581
9146262	JA5037	9443896	AB5440	12694402	JN303	0017507000	BG490	22032152	BK570
9146266	JA5038	9443897	AE5170	12698106	JN303	0017596900	BG480	22032152F	BK570
9146603	HR800	9458178	NA5017	12714838	JN302	0017751800	BF100	22032153	BP260
9157510	JD5117	9458309	NA5179	12714978	AG5270	0017779904	BW340	22032153F	BP260
9157567	JR5030	9458503	JD5289	12716999	JA5044	0017796791	BF170	22032154	BK580
9158057	PA5025	9458534	JD5288	12761910	BK640	0017796891	BF100	22032154F	BK580
9162593	GX392	9458535	JD5297	12764247	NA581	018710507	NB384	22032185F	BK570
9166497	JD5280	9549050	ET560	12764254	NA581	018710507A	NB384	22032186F	BP260
9169079	BT560	9561800	HR569	0551110000012853300	HC341	018710507B	NB384	22032187F	BK580
9175902	NB847	9602087	JH434	0012853400	HC341	18801000	NF692	22032245G	JP068
9180611	JC152	9612547U	NF677	0012857000	NF694	19700000	DV150	022103383F	AG5000
9185695	AC5630	9612552U	NF637	13063334	NA5016	0019971241	PA815	022103383K	AG9610
9186404	JD5281	9690116	KG664	13063417	HBS174	0019977447	PA815	022103383M	AG9610
9186412	JD5282	9849061	CC5630	13066303	HR641	020012306A	HR599	022103384L	HBS466
9186609	JJ501	9851103U	GF492	0013166700	BF100	020012326A	HR800	022103384M	HBS466
9194642	DY253	9855561	DX652	13177613	HBS175	20120990	NA580	022103483E	JM7045

OE reference	▲ Payen	OE reference	▲ Payen	OE reference	▲ Payen	OE reference	▲ Payen	OE reference	▲ Payen
022110235	JM019	026103383Q	BM360	028129717D	JD170	030253039H	JD5318	032410235	JM053
022110235A	JM019	26106675	HR805	028198011B	EA801	030599100	FJ232	032410235A	JM053
022110431	JH015	026107675	HR805	028198011C	EA801	030599100A	FJ232	032410271	AJ650
022110602	NJ042	026109675	HR569	028198011D	EC030	030599100C	FJ232	032410271A	AJ650
022110602B	NJ042	026121041P	KA5020	028198012B	DV850	030599100D	FJ232	032410271B	AJ650
022111399	NJ040	26126159	NF560	028198012C	DX800	030599100E	FJ232	032410271C	AJ650
022113111	JA021	26126889	NF554	028198012D	DV850	30637066	AE5560	032410431	JH040
022113462	JB802	026129589A	JC152	028198012E	DV851	30637067	AG8320	032413111	JA086
022133237A	JD5857	026129717	JC478	028198012F	DX801	30637336	AE5140	032499100	FJ651
022133237C	JD5874	026129717D	JC478	028198025	HM5058	30650521	AE5260	032499100A	FJ651
022210271C	AJ230	026198012F	DM360	029099100	FJ232	30650522	AE5270	032499100B	FJ651
022210271D	AJ230	026198012K	DM363	029099100C	FJ232	30650523	AE5280	032499100C	FJ651
022210271E	AJ230	026198012S	DM361	029099101	CJ232	30650524	AE5290	32672446	NF634
022210271F	AJ230	026198012T	DM363	29105245	NB953	30650525	AE5300	32674939	DH696
22454009R	PA349	026198025A	HL457	29740682	NB775	30731261	AE5260	32677832	HC354
22472090	PA349	026198025C	HM5053	0029903722	HBS349	30731262	AE5270	32705139	DH693
22478009	PA217	027103385	HBS028	0029970847	NB975	30731263	AE5280	32771583	NF722
022531503	DM690	027103385A	HBS028	0029978246	NA380	30731264	AE5290	32774325	BT080
023103383	BV880	027103385C	HBS028	30003780	HR800	30731265	AE5300	32844375	JB997
023103383B	BV880	027103483D	HL606	030103085A	NA5001	30757227	NA5191	32873473	BH690
023198009A	GM690	027109675	HR599	030103171K	LK5011	30874307	NF678	32875155	JN555
023198009B	GM690	027129589A	JD282	030103171S	LK5013	30875617	JM5290	32875429	NF850
023198012	DV880	027129589B	JD282	030103383AH	BZ180	30875618	JM5291	32875551	BL970
23540139	AC5320	027129717C	JD281	030103383AK	AA5410	31007628	LT726	32877102	EL960
23540159	AC5340	027129717E	JD281	030103383AT	AD5640	31010366	JN248	32879611	BL960
24401453	AE5920	027198012E	DM361	030103383BE	AD5630	31010481	JB851	32879629	BL980
24401490	JD5399	027198012H	DM365	030103383J	BL570	31038391	NF369	32978850	JB851
24401511	JD5398	027198012K	DM365	030103383K	BL570	31043011	JE648	33042383	KT005
24403772	JM5121	027198012L	DM360	030103383M	BL570	31064346	JM302	033129717B	JD278
24403788	JM5071	027198025	HL606	030103383MI	BL570	031103383C	BV460	033198012	DT590
24405819	HR5087	27559311	HM5278	030103383R	AV930	031103383D	BV470	033198012A	DT590
24405959	JD5401	028103171B	LK5006	030103384D	HBS362	031103383E	BV480	33420621	DL910
24407477	JD5147	028103383AH	BV850	030103483B	JN641	031103383M	BV460	33420886	BL910
24417040	JC824	028103383AJ	BV860	030103483C	JP075	031103383N	BV470	33424029	JD409
24428753	AH5030	028103383AK	BV870	030103483D	JN641	031103383Q	BV460	33429176	JH5011
24440093	JM5235	028103383AL	BV850	030103483G	JN641	031103383QM	BV460	33430547	BX080
24454151	HBS253	028103383AS	BX800	030103483K	JP074	031103383R	BV470	33434309	BL960
24458336	JD5400	028103383AT	BX810	030103609	JJ183	031103383RN	BV470	33434317	BL970
24465791	NA5174	028103383BA	BX820	030121043D	KA5025	031103383S	BV480	33434325	BL980
0024472539	NF786	028103383BH	BV850	030129589	JC259	031103383SP	BV480	33437930	JN732
0024472568	NF535	028103383BJ	BV860	030129717	JD246	031198012A	DV460	33438611	BS020
0024472608	NB775	028103383BK	BV870	030129717D	JD246	031198012B	DV460	33438623	BS010
0024472650	NF791	028103383BP	BX800	030129717F	JD597	31964346	JM302	33438631	BL970
025101343B	BM690	028103383BQ	BX810	1160030165010	JE696	32022003	CF070	33438649	BS030
025129717C	JD237	028103383BR	BX820	030198011	EV460	032103383G	BY620	33440447	DL916
025198009A	GM690	028103383F	JN914	030198011A	EB961	032103384	HBS075	33440504	DL916
025198009B	GM690	028103483F	JN914	030198012	DL572	032103609B	JJ183	33442617	HR569
025198012	DM690	028103483G	JP003	030198012A	DL572	032103609D	JJ183	33443037	BL910
025198012A	DM690	028103483H	JN914	030198012B	DL574	032110271B	AJ650	33443136	JD409
025198012B	DM690	028103500	NA5278	030198012C	CY930	032129717C	JD487	34022002	EF075
026103085A	NA5001	028103609A	JJ140	030198012D	DL573	32134611	BH690	34022013	HJ013
026103085F	NA5001	028103609B	JJ140	030198012E	CA5500	032198012	DV620	34062353	AF070
026103383	BM360	028103609D	JJ140	030198012F	CA5410	032198012A	DZ180	034103383	BM840
026103383K	BM360	028103717D	JD170	030198025	JN641	032198012B	DZ181	034103383A	BM840
026103383M	BM360	028129589A	JC152	030199100	FJ232	032253039B	JD488	034103383AA	BM840
026103383P	BM360	028129589B	JC152	030253039A	JC259	032253039E	JA5043	034103383AD	AY960

INTERCHANGE OE → PAYEN

Vergleichsliste OE → Payen • Références croisées 1ère Monte → Payen
Intercambio entre equipo original y Payen

OE reference	▲ Payen	OE reference	▲ Payen	OE reference	▲ Payen	OE reference	▲ Payen	OE reference	▲ Payen
034103383D	AY960	035198012L	DD621	038103171S	LK5012	40004190	NB814	046198011	EW860
034103383G	BM840	035198012N	DM840	038103383AL	BZ040	40004200	NB815	046198012A	DW860
034103383R	BM840	035198025E	HL460	038103383AM	BZ050	40004250	NB742	46402220	JD566
034103385C	HBS269	35310176	BY360	038103383AN	BZ060	40004260	NB825	46402972	AY430
034103483J	JN438	35313261	JE248	038103383CH	AG8940	40004270	NB818	46402972J	AY430
034115147	NB716	35476159	JC152	038103383CJ	AG8830	40004300	NB732	46404034	NA5057
034115147A	NB716	036103085A	NA5180	038103383CK	AG8950	40004340	NA5051	46405250	JS068
34129277	JD602	036103085H	NA5185	038103383CP	AG9630	40004370	NA5052	46410505	JD340
034129589A	JD603	036103383A	BL570	038103383CQ	AG9640	40004400	NA5053	46410880	JD342
034129717E	JD327	036103383AB	AC5280	038103383CR	AG9650	40004450	NB730	46410890	JD342
034129717F	JD171	036103383AL	AB5701	038103383DE	AF5381	40004750	NA5177	46410891	JD342
034129717K	JD602	036103383AM	AB5701	038103383DF	AF5391	40004930	NA5187	46410960	BX030
034129717M	JC261	036103383AN	AC5280	038103383DG	AF5401	40004940	NA5187	46412116	JD5143
034198011	EX995	036103383C	BL570	038103383E	BZ030	40005010	NB825	46412804	JR749
034198011A	EC010	036103383F	BL570	038103383F	BZ020	40100070	NP067	46414221	BT300
034198011B	EC010	036103383G	BL570	038103383G	BZ010	40100080	NP068	46414437	JD228
034198011C	EX995	036103383K	AA5500	038103383H	BZ040	40100300	NA5055	46414438	JD343
034198012B	DT820	036103383M	BL570	038103383J	BZ050	40100311	NF833	46414567	AY460
034198012E	DT820	036103383N	BL570	038103383K	BZ060	40100314	NF833	46416033	BT300
034198012L	DT820	036103383Q	AB5701	038103384	HBS264	40100320	NP067	46416034	BT320
034198012M	CY960	036103384	HBS360	038103384A	HBS311	40100321	NP068	46416876	NF887
034198025	HL460	036103384B	HBS249	038103483D	JM5203	40100324	NP068	46420638	HBS130
034198025A	HL460	036103384B	HBS471	038103483E	JM5120	40100330	NP067	46425904	JD464
034198025D	HL460	036103384E	HBS316	038113111	JA021	40100331	NP067	46425908	JD465
034198025F	HL730	036129717E	JD5228	038113111A	JA021	40100334	NP067	46426046	JD148
34202311	JA439	036129717G	JD5373	038198011	EC060	40100340	NP068	46426755	AY320
34526046	BX080	036198011	EB5700	038198012	DZ010	40227010	NJ692	46427653	JD343
34536755	AE5040	036253039C	JD5233	38821480	NA5038	041125403N	DL951	46430687	HBS051
34659680	JD409	036253039F	JD5298	39026002	EF462	041126452	DR581	46430688	HBS051
34666172	JD419	036253115	JE154	39026003	CF473	42095800	NA380	46431639	BR680
34676056	BX600	036253115A	JE154	39066353	AF470	42531636	NP067	46431640	BR690
35017755	HR805	036599101	CJ652	39066363	AF470	43252030	NJ844	46431641	BV700
35070259	JJ551	036599101A	CJ652	039198012C	DL491	044103383D	BW790	46431642	BR700
35070333	JC146	36812547	BC240	0039403920	NB866	044103609D	JJ609	46432087	JP063
035103383G	BD620	037011399	NJ099	00039621840	HR805	044198011	EA800	46432735	JD150
035103383J	BD620	037103383L	BY630	0039902522	HBS474	044198012	DW790	46434102	BV670
035103383K	BD620	037103483AC	JN969	0039970347	NA5264	045103383C	AC5190	46434591	NA5058
035103483C	HL460	037103483C	JN964	40000160	NA5045	045103383D	AC5200	46434596	BY380
35103609	JJ184	037108483C	JN964	40000170	NA5046	045103383E	AC5210	46434691	KV122
035121171C	PA459	037115220B	JH5023	40000320	NB633	045103383F	AD5650	46435397	JD225
035121717C	PA459	037129717D	JD599	40000323	NB633	045103383G	AD5660	46435513	NF888
035129717F	JC261	037129717F	JD281	40000920	NB633	045103383H	AD5670	46436047	HR599
035129717G	JC261	037198011C	EG873	40003300	NA5045	045103483C	JM7032	46437256	JP064
035129717H	JC261	037198011E	ES471	40003310	NB727	045115441	KK5522	46437440	JD580
035129717J	JC261	037198011G	EB970	40003460	NB730	045128717	JD5278	46440885	HR800
035129717M	JC261	037198012B	DT811	40003630	NP068	045129717	JD5278	46442435	AY550
35149434	NA5273	037198012E	DT819	40003634	NP068	045253039	JD5279	46442436	AY560
35178607	HR646	037198012G	DT811	40003637	NP068	045310271	AJ120	46442437	AY570
35178938	HR800	037198012J	DT81B	40003640	NP068	045310271A	AJ120	46444964	BD790
035198011A	EX995	037198012K	CY940	40003650	NP067	045310271AN	AJ120	46447765	AY520
035198012	DD620	037198012L	DY753	40003657	NP067	045311399	NJ040	46449944	AY530
035198012B	DD621	037198012M	CY941	40003760	NA5062	045313462	JB802	46449945	AY540
035198012C	DD622	037253039D	JD600	40003850	NF833	045920930	JE674	46451593	AC5140
035198012F	DM840	037253039F	JD606	40003854	NF833	045920970	JC251	46451594	AC5150
035198012J	DD620	038103085C	NA5124	40003990	NA5049	046103483A	JN967	46451595	AC5180
035198012K	DD622	038103085E	NA5106	40004000	NA5050	046109675A	KJ502	46451596	AC5160

OE reference	▲ Payen	OE reference	▲ Payen	OE reference	▲ Payen	OE reference	▲ Payen	OE reference	▲ Payen
46452670	AC5169	046671398	NA5139	048198012C	DY750	53009549AB	AC5600	55192551	AY320
46452671	AC5170	46737936	JC738	048198012D	DY750	53010310AB	HA5015	55193766	KA5032
46454063	BY410	46739135	AA5780	048198383D	BY750	53020490	AG9690	55194045	JM5176
46454064	BE450	46739136	AA5790	049103051C	NF857	53020673AC	AD5760	55195892	AD5840
46454065	BY430	46739137	AA5800	049103383	BG870	53020752AB	HR5077	55195910	AD5850
46457491	KL476	46739261	JM5029	049103383A	BG870	53020754AB	AC5610	55195911	AD5860
46459863	KL479	46743167	HR5095	049103383D	BG870	53020788	NA5173	55197283	AD5830
46460125	NF888	46744434	KL476	049103383E	BG870	53020877	HM5064	55197598	JM5204
46461755	JD467	46748519	JM5181	049103383K	BG870	53020878	HM5064	55197682	JD5375
46461883	BW340	46749904	AY520	049103384B	HBS024	53030812	HA5016	55198843	AD5800
46461884	BW350	46749905	AY530	049103385	HBS029	53030813	HA5016	55198844	AD5810
46461885	BW360	46749906	AA5580	049103385A	HBS042	053103383	BT810	55198845	AD5820
46462481	BT260	46752127	AB5150	049129717A	JC478	053103383A	BT810	55199355	JD5375
46462772	JC738	46753222	KK5154	049198012C	DG871	053103383B	BT810	55202010	AG7400
46464114	JM5018	46754320	JD148	049198012H	DG871	053198012A	DT813	55202011	AG7440
46465291	JF145	46757318	JD150	050103383	AY940	053198012B	DT813	55202800	AG7310
46467203	JN973	46757321	JD464	050103383A	BZ910	053198012C	DY751	055253115A	JE117
46467746	JD228	46757609	JD465	050103383B	BZ910	053198012D	DY752	55351605	JD5256
46467747	JD468	46759989	JM5019	050198012A	DM360	053198012E	DT813	55353885	AC5460
46468413	AA5720	46764762	HBS370	050198012B	CY942	054103383	BT820	55561181	JR5030
46468414	AA5730	46767211	AD5970	51019700	FF5980	054103383G	BT820	056103489A	HL457
46468415	AA5740	46767976	KK5156	051103483A	JP024	054103609	JJ184	056103609A	JJ140
46470334	HR814	46771926	AD5840	051103483E	JP024	054115147B	NB716	056103609B	JJ140
46473174	BE440	46771927	AD5850	051103609E	JJ576	55110136	HBS379	056129589	JC152
46473175	BE450	46771928	AD5860	051198011A	ET811	55110137	HBS379	056129589A	JC152
46473176	BE460	46771929	AD5910	051198011B	ES471	0055116500	J8837	056129717	JC478
46473336	AY460	46771930	AD5920	051198012A	DT812	0055116900	JN238	056198025	HL456
46475573	HBS297	46771931	AD5930	051198012B	DM366	55180937	NA5230	056198025A	HL457
46475574	HBS297	46772389	JA5035	051198012C	DM367	55183371	AG7380	056198025B	HL456
46477509	JF184	46772390	JA5036	051198012D	DZ910	55184024	AG6220	057103384A	HBS361
46479905	AA5570	46774976	AD5960	051198025	HL731	55184740	AG7410	058103383K	AY970
46480910	JA752	46784147	KK5157	052103383AA	BL560	55184741	AG7420	058103383M	AY970
46513955	JM5176	46803532	KK5158	052103383AB	BL560	55184742	AG7430	058103385A	HBS171
46514710	HA5005	46811291	JA5035	052103383G	BL560	55185775	AD5830	058103609	JJ610
46514722	HA5005	46814120	JM5176	052103383H	BL560	55186663	KK5646	058103609E	JJ610
46525557	JD226	46814174	JM7055	052103383N	BL560	55187650	AD5970	058129717B	JD604
46526271	JA5006	46816020	JD5376	052103383Q	BL560	55187704	AD5870	058129717C	JD5820
46527523	JD225	46817515	AD5800	052103383R	BL560	55187705	AD5960	058198011	EY840
46529117	BZ790	46817516	AD5810	052103383T	BL560	55187899	AD5800	058198012	CY970
46529118	BZ800	46817517	AD5820	052103483A	JM154	55187900	AD5810	058198025A	HL732
46529119	BZ810	46820225	JD5143	052103483B	JN783	55187901	AD5820	058253039G	JD605
46533307	JR5001	047103383E	BT580	052103483C	JM154	55189864	AE5240	58800958	DD790
46539824	LK5001	047103383F	BT580	052103483E	JM154	55189950	AE5240	58816747	DP070
46541379	BP290	047103383J	BT580	052103609A	JJ183	55189962	AA5420	059103085A	NF637
46543439	KK5002	047129717E	JD5812	052129589	JC259	55190350	AD5840	059103085B	NF637
46546120	AE5240	047253039H	JD5849	52177600	CC5630	55190351	AD5850	059103085E	NF637
46548441	JM5003	047253039J	JD5818	052198011A	EA900	55190352	AD5860	059103383AA	AC5970
46548450	JA5008	047253050	JD5817	052198012AB	DL570	55190353	AD5910	059103383AB	AC5980
46548459	JA5011	048103383B	BT810	052198012AF	DL561	55190354	AD5920	059103383CM	AG8880
46549807	AA5590	048103383D	BY750	052198012D	DL570	55190355	AD5930	059103383CN	AG8860
46552317	KK5155	048129717A	JD483	052198012E	DL561	55190356	AG7390	059103383CP	AG8890
46552427	KK5001	048129717B	JD482	052198012G	DL571	55190357	AA5570	059103383CQ	AG8900
46552748	JM5028	048129717D	JD5235	052198012P	DL570	55190359	AA5780	059103383CR	AG8870
46554619	JD5155	048198012	DT814	052198012R	DL570	55190360	AA5790	059103383CS	AG8910
46556651	HR5088	048198012A	DT815	052710271	AJ630	55190361	AA5800	059103383T	AC5960
46641908	HR800	048198012B	DT81C	53006695	JM7050	55192265	HBS353	059103384	HBS265

INTERCHANGE OE → PAYEN

Vergleichsliste OE → Payen • Références croisées 1ère Monte → Payen
Intercambio entre equipo original y Payen

OE reference	▲ Payen	OE reference	▲ Payen	OE reference	▲ Payen	OE reference	▲ Payen	OE reference	▲ Payen
059103483M	JM7047	60515502	JR349	60569897	BW310	60654310	NF888	606755017	AN350
059103483N	JM7046	60515611	JE447	60569899	BW300	60655592	JM5002	60755077	GT340
059129717G	JD5810	60515628	JE442	60569900	BW260	60655830	NF888	60777036	DT360
059129717J	JD5872	60515780	NA5066	60569901	BW300	60659190	AA5420	60777037	GT360
059198001A	CC5960	60515781	NA5066	60569902	BW260	60659746	JD466	60777049	DT360
059198025	HM5223	60515793	JA829	60570141	JD221	60659747	JD271	60777051	CN308
059253039B	JD5851	0060516700	JA840	60570142	JJ450	60659758	AA5420	60777052	DC372
0059979047	NB975	60517645	JC507	60570351	BT390	60664260	JA5007	60777053	GT351
59999294	LB025	60518068	BT360	60570352	BT380	60664642	AA5420	60777054	DT350
60502831	NA5063	60519104	JH526	60570617	NJ951	60665425	HBS262	60777055	GT360
60502891	NA5063	60521877	KV004	60572819	HBS108	60667293	JM5024	60777056	GW260
60502910	JA898	60523241	BH850	60572821	HBS108	60667294	JM5023	60777057	DW260
60502913	NA5064	60523245	BC370	60572823	HBS108	60667495	AA5420	60777058	GT350
60502984	JA899	60525029	JD014	60573536	JD587	60671874	AD5870	60777059	GC374
60503075	JH565	60525316	JN811	60581645	AN350	60677983	AD5950	60777061	GH856
60503077	JA898	60525822	BT340	60581846	AN350	60700088	JP004	60777066	GW300
60503078	KV124	60534228	JD017	60583721	JN581	60707153	JE442	60777067	DW300
60503099	AN350	60534406	HR815	60583742	JC928	60709171	AF240	60777068	GH858
60503131	NA5065	60534424	JC497	60584488	AY630	60710050	JH526	60777069	DH855
60503303	JN588	60534664	JN806	60586217	HL701	60711523	AN300	60777073	DT370
60503304	JA899	60534705	JD018	60589234	BK570	60713115	FF24R	60777074	GT370
60503916	JR349	60534987	BW310	60589892	JD272	60713116	CF24N	60777075	GT370
60504851	JD221	60534988	BW300	60591809	BP990	60714997	BC370	60777076	DT370
60505485	BE620	60535949	HR801	60591810	BE620	60721103	GT360	60777104	GP990
60505488	BE620	60542965	JN810	60591811	BE620	60722008	FF24R	60777105	GT340
60506636	JD223	60543571	BW260	60591812	BP990	60722057	FF24R	60777118	DE623
60507000	JE696	60544360	KV102	60593329	BT360	60723677	BC370	60777119	GE622
60507020	JE696	60546397	JD565	60596115	BW710	60723678	BC370	60777120	GE622
60507102	NA5066	60548448	BT340	60596116	BW720	60724725	DC372	60777155	GW280
60507107	NA5066	60548495	HR800	060596952	JD271	60724921	BH850	60777156	DW280
60507155	BK570	60548751	BT380	60602071	AY640	60726565	GH856	60777246	GW260
60507156	BP260	60549557	BP990	60603436	NA5069	60727820	CN306	60777247	DW260
60507157	BK580	60552577	BW410	60604866	JJ535	60730162	DC372	60777248	GW300
60507402	NA5163	60558499	JD016	60605898	BK580	60732778	DK570	60777249	DW300
60507414	KA738	60558500	JD018	60605899	BP260	60732780	DK570	60777313	GH858
60507557	HR800	60558501	JC497	60605900	BK570	60733096	GK570	60777314	DH855
0060507576	JD015	60558505	JD235	60607218	HL700	60733352	JD018	60777316	CN308
60507652	JD025	60559070	KA738	60607219	HL700	60734690	CN306	60777317	DC372
60507653	JF123	60560701	NA5066	60607745	AY610	60735063	CN308	60777318	GH856
60509396	HR280	60560702	NA5066	60608122	AY620	60735218	BH850	60777321	DT350
60512669	NA5066	60560916	BT350	60608894	AY500	60741413	GT351	60777322	GT351
60512948	JN807	60563670	JD224	60608895	BW710	60741414	DT350	60777615	DW410
60512949	JN807	60563671	JD222	60609156	AY490	60743549	GW260	60777616	GW410
60513135	JJ515	60565962	BT350	60609159	JN940	60743551	DW260	60777617	DW300
60513181	JD222	60566212	NA5163	60609978	JP070	60743841	GC374	60777618	GW300
60513311	JN812	60566395	BW280	60609979	JP071	60743855	GH856	60777688	KV123
60513316	JN812	60566396	BW290	60610985	NA5163	60743916	BW260	60777692	KV124
60513350	KV086	60567018	BC370	60611531	JD273	60750004	DT420	60777695	JD221
60513358	KV086	60567019	AN300	60611545	JD466	60750006	DT420	60777697	JE696
60513394	NA5068	60567020	BH850	60612112	JS069	60750597	DE622	60777701	JE447
60513395	NA5068	60567604	NA5163	60616864	BY390	60750598	FN353	60777704	KA350
60513396	NA5068	60567605	NA5068	60616867	HBS262	60750651	DE622	60777747	JN588
60513428	BT350	60567606	NA5068	60619673	BY390	60750652	CN353	60777756	JA840
60513869	JD586	60568808	JN814	60621381	JD466	60750825	DP990	60777758	JH526
60514910	BP990	60568809	JN813	60625132	JD272	60750829	GP990	60777771	CN306
60515501	KD383	60569895	BW300	60630269	JD224	60755016	BE620	60777775	CN306

OE reference	▲ Payen	OE reference	▲ Payen	OE reference	▲ Payen	OE reference	▲ Payen	OE reference	▲ Payen
60777776	CN306	60778155	GH856	60808412	JN808	60816187	CY520	068103383Q	BH720
60777780	CN306	60778157	DC372	60808430	JN807	60816190	AA5420	068103383R	BH730
60777781	CN306	60778158	DC373	60808640	BR680	60816385	JM5028	068103384A	HBS018
60777783	CN308	60778159	GC374	60808641	BV690	60816423	AA5420	068129589A	JC152
60777790	DT420	60778160	GH856	60808642	BW980	60816451	FA5560	068129717A	JC478
60777792	DT420	60778161	CN353	60808659	JN459	60816452	FA5560	068129717E	JC243
60777795	GT340	60778162	DE622	60809643	BV680	60816453	CA5560	068130219	PA136
60777797	GT350	60778163	FN353	60809644	BV690	60816562	AA5780	068198012A	DD501
60777803	GT370	60778164	DE622	60809645	BW980	60816563	AA5790	068198012D	DD501
60777804	DT370	60778165	CN353	60809849	NA5053	60816564	AA5800	068198012E	DD502
60777847	GT370	60778166	DP990	60810586	BT390	60816595	CA5780	068198012F	DD502
60777939	DK570	60778167	GP990	60810669	HR800	60841220	AC5150	068198012H	DD502
60777949	GT360	60778168	FF24R	60811338	NA5068	61164304	NA473	068198012L	DD501
60777952	DC372	60778169	DT360	60811349	JD271	063610271	AJ630	068198171	NA5133
60777954	GH856	60778170	GT360	60811572	HR800	063610602	NJ367	68420934	NA869
60777955	CN306	60778171	GC374	60811872	HR800	063612117	PA426	68421601	NA869
60777956	FN307	60778172	GC374	60811964	NA5187	063613111	JC775	68422724	NA5138
60777958	DC372	60778173	GC374	60812037	NA5163	1140065862000	CG8020	68422732	NA5016
60777962	GC374	60778175	DE623	60812121	AC5140	066103483F	JM5234	68422740	NA5017
60777963	GH856	60778176	GE621	60812122	AC5150	67332295	HBS033	68423474	HBS303
60777967	CN353	60778177	GH858	60812123	AC5180	68004099AA	FG9660	069103383CE	BT470
60777968	DE622	60778178	DH855	60812124	AC5160	068103085A	NA5001	069103383CP	BT470
60777969	FN353	60778179	DC372	60812490	BW720	068103085E	NA5001	069115147	NB716
60777970	DE622	60778180	GH856	60812729	JD273	068103171F	LK5006	069115147C	NB716
60777971	CN353	60778182	DC372	60812985	KL476	068103383AE	BN080	069198012B	DL491
60777972	DP990	60778234	GK572	60813045	JC738	068103383AF	BN090	069198012C	DL491
60777973	GP990	60778235	DK570	60813241	AY640	068103383AG	BN100	069198015C	DL491
60777974	FN353	60778236	GK570	60813258	JP071	068103383AH	BN080	069198015D	DL491
60777975	DT360	60778304	DW260	60813259	JP070	068103383AJ	BN090	069198025	HL462
60777976	GT360	60778305	GW260	60813744	JD468	068103383AK	BN100	069198025C	HL463
60777978	GC374	60778459	GK572	60813760	BT380	068103383BA	BH720	0069971247	NB971
60777981	GP990	60778568	JN652	60814219	AC5140	068103383BB	BH730	0069975347	NC065
60777982	DE623	60778648	DT448	60814221	AC5180	068103383BC	BN080	070103383J	AG8920
60777983	GE622	60778765	DT340	60814222	AC5160	068103383BD	BN090	070103383K	AG8820
60777984	GW280	60778767	CN355	60814337	JR5001	068103383BE	BN100	070103383L	AG8930
60777985	GW260	60778768	FN355	60814374	NF888	068103383CE	BT020	70224654	NF369
60777986	DW260	60778769	GE623	60814599	AY520	068103383CP	BN940	71010135	HBS381
60777987	GW300	60778798	DT380	60814600	AY530	068103383CQ	BN950	071103383	AG7800
60777988	DW300	60778799	GT380	60814601	AY540	068103383CR	BN960	71198011	EG7800
60777991	GH858	60778829	DW260	60814602	JP063	068103383DB	BN940	71711023	GW721
60777992	DH855	60778830	GW260	60814607	JD580	068103383DC	BN960	71711024	GW721
60777994	CN308	60778967	DK573	60814724	CY550	068103383DD	BN950	71711143	GY411
60777995	DC372	60778968	GK573	60814725	FY550	068103383DE	BN940	71711144	DY410
60777996	GH856	60778969	GK573	60814952	JP064	068103383DF	BN950	71711279	DW711
60777999	DT350	60778979	JP068	60814966	AY550	068103383DG	BN960	71711280	GW711
60778000	GT351	60805104	JC662	60814967	AY560	068103383EF	BT020	71711493	DW322
60778001	DW280	60805718	NA5053	60814968	AY570	068103383EH	BN940	71711517	CY320
60778051	DR040	60805835	HR800	60814969	CY520	068103383EJ	BN950	71711518	FY320
60778115	GW281	60806695	BT440	60814970	FY520	068103383EK	BN960	71711735	DY390
60778116	DW280	60806762	KT465	60815726	JC738	068103383ET	BH720	71711736	GY390
60778117	DT380	60806887	DT370	60815877	KL476	068103383FA	BH730	71711936	DY382
60778118	GT380	60807143	JD153	60816179	JA5035	068103383FE	BT020	71711967	CY640
60778150	GT360	60807357	HBS092	60816183	JA5036	068103383FL	BN080	71711968	FY640
60778151	FF24R	60807621	HBS093	60816184	FY550	068103383FM	BN090	71712360	CY520
60778152	GC374	60807932	BW260	60816185	CY550	068103383FM+E3825	BN090	71712361	FY520
60778153	DC372	60808083	NA5163	60816186	FY520	068103383FN	BN100	71712434	CY620

INTERCHANGE OE → PAYEN

Vergleichsliste OE → Payen • Références croisées 1ère Monte → Payen
Intercambio entre equipo original y Payen

OE reference	▲ Payen	OE reference	▲ Payen	OE reference	▲ Payen	OE reference	▲ Payen	OE reference	▲ Payen
71712435	FY620	71718045	CA5590	71740084	EG7450	75047003	CK663	078198025	HM5224
71712628	AA5540	71718129	FA5560	71740362	DP289	75047005	CH861	81026800	HBS313
71712630	AA5550	71718130	CA5560	71740655	CG7380	75047006	CH861	82293355	HR599
71712830	FY550	71718142	CB5150	71740961	CG7410	75047007	EH750	82302903	JE388
71712831	CY550	71718309	GP286	71740962	EG7410	75047016	NA585	82347860	JE744
71712889	CY610	71718333	CA5780	71740964	CG7390	75047060	JM315	82380384	JC662
71712890	FY610	71718365	NF888	71741374	CE5242	75047063	CG902	82384663	JF043
71712891	AA5520	71718389	GP286	71744285	CD5800	75047066	DJ202	82473209	JE744
71713031	DX030	71718390	DP286	71744286	ED5810	75047198	CF473	83504346	CC5600
71713032	GX030	71718658	CA5560	71744287	ED5820	75061756	CF070	84142413	NF843
71713041	NF888	71718659	FA5560	71744288	CD5820	75061762	CD950	88143456	NA774
71713629	DY391	71718738	LK5001	71744445	DP289	75061769	CK525	0089971547	NB975
71713630	GY391	71718831	HA5005	71745117	CE5242	75061785	EF070	0089971647	NB975
71713631	DW722	71718852	CD5970	71747636	CG7310	75061795	EF074	0089972646	NA448
71713632	GW722	71718853	FD5970	71747638	CG7310	75061796	EF075	0089975247	NB971
71713633	DW712	71719654	CE5181	072103383CT	BW680	75061799	EF462	90002406	JN041
71713634	GW712	71719751	CE5180	072103383DA	BW690	75061807	EH761	90002418	JN068
71713675	DW322	71719779	EA5420	072103383DB	BW700	75061981	JM261	90002472	JM956
71713695	DX391	71728337	GX410	072103383DJ	BG940	75061982	JM302	90005299	HC295
71713696	GX410	71728339	GX392	072103383E	BG940	75061983	JM315	90005374	DN041
71713723	CY640	71728825	EV684	072103609B	JJ551	75061986	JM413	90006778	DL550
71713724	FY640	71728826	EB5150	072198012	DM660	75061988	JM478	90007227	DM380
71713861	AY470	71728827	EV670	072198012A	DM660	075103383E	BZ930	90007707	ET820
71713924	AY500	71728831	EA5780	072198025	HL469	075103483A	HL728	90009378	DK470
71713949	AY450	71728839	EE5180	072198025A	HL728	075103483F	HL728	90019654	HR291
71713956	AY480	71728880	EE5242	072198025B	HL469	075198011A	EX980	90019655	HR336
71713987	CY680	71729223	JA5005	072198031	JC152	075198011B	EX980	90020184	BN010
71714019	AY490	71729499	CD5800	73001262	NP068	075198012A	DM660	90027135	NB628
71714093	AY510	71730147	EA5420	073103483A	JN849	75452930	JB869	90027731	BJ170
71714142	CY610	71730148	EA5420	073198012A	DM700	75491221	JB868	90067012	HR291
71714143	FY610	71730149	ED5960	73500063	JM5259	75491223	JB833	90067926	NB628
71714940	DW723	71730213	EE5181	074103383AG	AF5330	75491225	JB864	90076086	NB469
71714941	GW723	71730214	CD5840	074103383AH	AF5320	75491352	JB830	90076919	JJ120
71715110	BV940	71730404	EE5181	074103383AJ	AF5310	75491733	BF600	90076934	BK470
71715130	AE5550	71731575	CE5240	074103383M	AF5340	75491735	BG450	90080727	NB697
71715448	AY460	71732900	CE5181	074103383N	AF5350	75501082	JB864	90086948	NA380
71715698	DZ790	71734258	ED5910	074103383P	AF5360	75505394	JB830	90091657	JC280
71715699	DZ790	71734259	CD5910	074103383R	AF5310	75513004	BF600	90091769	JE119
71716050	CA5560	71736222	CD5970	074103383S	AF5320	75513006	BG450	90091791	JC281
71716051	CA5560	71736240	CE5240	074103383T	AF5330	75513624	DG452	90091903	NC006
71716583	JA5005	71736243	CE5181	074103483	JN915	75516398	JN232	90091926	NB698
71716584	JA5005	71736315	CD5800	074103483B	JN915	75518008	GF492	90096047	NB628
71716585	JA5005	71736793	EE5242	074103609B	JJ501	75530731	JN426	90096964	JN344
71716684	JA5010	71737120	GR620	074103609F	JJ501	076198011	EX980	90106350	NB701
71716868	DV672	71737128	DR620	074129717	JD312	078103383E	AY060	90106425	JJ200
71716870	DY383	71737153	CD5960	074198011A	EB960	078103383K	BZ960	90106465	JC436
71716871	GY383	71737163	CY320	074198011B	EA5470	078103385A	HBS064	90106468	JC437
71717683	CA5420	71737164	FY320	074198012	DW830	078103385F	HBS064	90106506	JN453
71717685	CA5420	71739202	KG5337	074198012A	CA5470	078103385K	HBS270	90106610	JC283
71717833	FY550	71739214	JD5868	75046292	NA301	078103483C	JM5166	90106615	JC282
71717834	CY550	71739374	HBS416	75046293	NA448	078103483L	JM5166	90114587	ET820
71717836	CY520	71739387	AG9580	75046298	NA579	078103609F	JH5118	90114589	EK470
71717900	CA5421	71739933	CE5180	75046299	NA580	078198011A	EY850	90118383	BL550
71717901	CA5421	71739945	CG6220	75046830	JM477	078198012	DT660	90122134	HR336
71718011	GX392	71739971	CA5561	75046833	JM510	078198012A	DY850	90122607	NB701
71718012	DX392	71740083	EG7390	75046834	JM550	078198012D	DZ960	90122996	BL010

OE reference	▲ Payen	OE reference	▲ Payen	OE reference	▲ Payen	OE reference	▲ Payen	OE reference	▲ Payen
90122997	BL020	90231631	JD5765	90350024	BS260	90409678	BL550	90487874	JN955
90122998	BL030	90231792	BK470	90351504	JC757	90409679	BK470	90487889	NF637
90126607	NB701	90231938	BN040	90352112	NB698	90409682	BN040	90500342	JC436
90128293	JE120	90231939	BN040	90353146	JN924	90409693	JJ120	90500532	JJ574
90128529	BM380	90233236	NB698	90353443	JC280	90409709	JC823	90500805	NA5069
90136297	NB700	90233238	NB806	90353579	JC756	90409710	NB5720	90501195	JJ573
90136849	NB697	90233244	NB697	90354545	JN626	90409877	BS260	90501525	JP009
90141910	EK470	90233720	BP800	90363443	JC280	90410036	JA499	90501526	JP008
90144262	HBS003	90237386	JN694	90371771	DY251	90410526	HBS054	90501641	JM5095
90156001	NB697	90264658	NB808	90391046	HBS002	90410697	JD459	90501647	JH5019
90156002	NB700	90264787	NB807	90392502	BV950	90410741	HR342	90501652	JD5202
90156004	NB701	90265553	JD430	90392518	EB950	90410753	BY300	90501653	JD5203
90156007	NC006	90271435	BL010	90392639	BT530	90410754	BY270	90501720	NB700
90156354	NB734	90271436	BL020	90392709	BW170	90411286	JJ459	90501944	JP016
90156855	NB700	90271437	BL030	90392751	DW170	90411386	JJ459	90502090	JJ617
90156857	NB469	90272342	HR291	90397612	BK020	90411752	JM5095	90502092	JH5119
90167457	EK470	90280360	BS720	90397690	DP820	90411753	JM5094	90502195	JH5057
90180294	HR343	90280462	NB806	90397692	DP810	90411814	JH5052	90502291	JD5204
90180500	NB700	90280464	NB807	90397696	DP800	90411816	JJ572	90502462	JD448
90180504	NB734	90280542	HR291	90397697	DL550	90411887	JD450	90509135	JD274
90180509	NB691	90284185	HR336	90397699	DK480	90412126	JD457	90509145	JD275
90180515	NB698	90284652	BL550	90397806	DK470	90412127	JD458	90509714	BP800
90180517	NB701	90284657	BL550	90397812	EK470	90412128	JD457	90509770	EY280
90180521	NB469	90284658	BK470	90397813	DS720	90412303	JN693	90509837	DY250
90180525	NB690	90285291	NC006	90397815	DP802	90412459	JD451	90509849	BY250
90183135	HBS163	90295205	EK482	90397819	EK485	90412701	HBS055	90510631	JD276
90188185	HR343	90295206	EK484	90398046	BK470	90412781	JP009	90510684	AY210
90188186	HR343	90295207	DP820	90398047	BL550	90412782	JP008	90510807	AY210
90190028	JJ200	90295209	DP800	90398048	BP800	90412846	JJ575	90511165	EY230
90190136	JC283	90295791	JN694	90398049	BP810	90421993	BN010	90511490	AY210
90190481	PA543	90298131	JJ120	90398050	BP820	90423026	JD456	90511492	CY221
90194295	JJ385	90298172	BR010	90398091	BM380	90423709	AG9570	90511798	EC130
90194974	BR020	90298173	BR020	90398092	BK480	90442252	EK484	90511878	EY300
90194975	BR030	90298174	BR030	90398347	DS260	90442262	JC823	90512823	DY271
90200349	BM380	90298195	NB628	90398572	EK481	90442263	DP803	90512825	DY270
90200737	BL550	90298205	NB884	90398575	DJ172	90442264	DS261	90528632	JJ615
90200738	BL550	90298949	JC823	90398797	BL010	90443459	BY270	90529438	JH5037
90200739	BL550	90299556	JN694	90398798	BL020	90444066	BY240	90529485	JD5223
90200740	BL550	90322816	BS260	90398799	BL030	90444862	HBS074	90529537	HBS253
90200742	BK470	90322930	JN923	90399186	BR010	90466480	HBS054	90529586	JM5085
90200743	BK470	90323252	BY340	90399187	BR020	90466638	JM950	90529957	JH5036
90200744	BK470	90323399	JC824	90399188	BR030	90467661	JP018	90530075	JM5048
90200745	BK470	90323445	BJ170	90409456	JD455	90467759	JJ616	90531106	HR5096
90200834	BR010	90323592	JN521	90409568	BM380	90467802	JC437	90531731	JD5149
90200921	JC756	90323853	JN626	90409569	BK480	90469379	JJ572	90531832	JR5030
90215011	JC757	90324060	HBS035	90409570	BP810	90470036	JD444	90536009	AC5460
90215026	BP800	90324263	JN693	90409572	JC436	90470103	JD5229	90536057	JD5196
90215296	DP800	90324544	BV950	90409583	JD5765	90470231	JD5269	90536199	JD5197
90215968	JN626	90325572	NB806	90409594	JN929	90470303	JD445	90536414	JM5092
90217059	NB575	90325839	BP810	90409640	JA415	90486686	HR343	90540061	AB5681
90220215	BP820	90349024	DS720	90409642	JC281	90487290	BY300	90540351	DP806
90220216	BP810	90349025	ES720	90409643	JC281	90487444	BY260	90540356	EY230
90220309	JN693	90349032	DS260	90409644	JC282	90487795	JJ537	90540357	HC5007
90220621	BJ170	90349033	DS260	90409645	JC281	90487796	NB431	90540460	AB5671
90231452	JE120	90349873	BY330	90409648	JD187	90487863	BZ110	90541019	BS260
90231580	BJ170	90349947	BJ170	90409652	JC155	90487864	BZ120	90542155	BY330

INTERCHANGE OE → PAYEN

Vergleichsliste OE → Payen • Références croisées 1ère Monte → Payen
Intercambio entre equipo original y Payen

OE reference	▲ Payen	OE reference	▲ Payen	OE reference	▲ Payen	OE reference	▲ Payen	OE reference	▲ Payen
90542156	BY340	91505787	BL650	93182932	CH5031	94226564	JJ204	95567410	DG452
90542157	BY350	91506833	HG087	93501128	NF841	94232468	BK500	95567411	GG452
90543010	AB5140	91506974	BM530	93501444	JN544	94235060	BK500	95569119	DG452
90543333	AY160	91507124	HR566	93502226	JJ283	94235280	BM330	95569120	GG452
90543334	AY170	91508054	JN547	93740012	FG8000	94235369	NJ322	95569123	DG542
90543335	AY180	91508290	NF746	93740053	FD5690	94235476	GD363	95569124	GG541
90543375	CB5140	91509974	BM530	93740055	FG7990	94236345	JE751	95586979	DN582
90543376	EB5140	91511138	KA611	94020262	NJ014	94239140	JN456	95590822	GL650
90543900	EB5670	91511857	HBS083	94021915	JE019	94239258	JJ345	95590823	DL650
90543909	AC5460	91515138	NF746	94022595	NJ060	94241516	GM370	95591804	JC415
90544049	AB5240	91517355	JN596	94026324	NJ265	94241518	DM370	95593775	GL830
090570008	AB5140	91520521	BM530	94026351	JH016	94248829HS	DM370	95598981	BR280
90570009	AB5240	91538218	JD5764	94026399	JC643	94250970	JN613	95602513	DJ720
90570322	NA5209	91538297	BM530	94026746	FX182	94251171	NJ449	95602514	GJ720
90571925	NA5108	91538611	BL650	94028187	JN408	94254788	GD363	95605462	DG452
90572108	JD5347	91538612	BR510	94028764	JJ192	94254789	DD363	95605463	GG452
90572656	JH5005	91538925	NF678	94029468	GJ650	94255345	GD363	95614597	GL650
90572788	AY170	91538926	NF817	94029787	NJ267	94255347	DD363	95619476	DT012
90572789	AY160	91539050	JD5763	94029937	GJ653	94258197	BN610	95619477	DS810
90572790	AY170	91539812	BL650	94030182	DJ652	94313803	JN776	95619749	GL830
90572791	AY180	92030773	JC282	94030188	BM370	94320618	HBS036	95625019	DF180
90573498	JM5059	92030808	JC757	94030585	NJ266	94324053	BP920	95636678	BL830
90602512	JM483	92060518	BP810	94032672	JJ376	94327063	NK103	95638362	JF067
91000883	NB469	92061971	EC100	94032673	JJ376	94334845	NJ454	95644580	DJ720
91007489	CK302	92063977	DY254	94033612	DM330	94339997	NJ323	95644581	DJ720
91013207	BB610	92065111	EC102	94039281	GN190	94367979	JH5058	95647731	DS731
91031880	CK302	92065112	DY255	94039282	DN190	94386441	AY840	95650948	DS820
91031881	CK302	92065529	JD5737	94101767	JN661	94386442	AY850	95650949	DS820
91033740	AK300	92065913	JH5096	94107568	NJ646	94386443	AY860	95654054	DV150
91053121	EG851	93010242	JJ283	94110559	PA658	94414300	DN610	95655248	DV150
91102913	CK302	93010402	JC423	94115243	DM370	94462559	JN661	95655249	DV150
91108402	KT754	93160143	CD5991	94124173	NJ875	94468654	NB734	96000436	JE189
91111863	BL390	93170143	AG9580	94129884	NJ446	94482157	NJ449	96003915	HBS082
91111872	JN414	93171267	CB5540	94145839	BK040	94580081	HBS377	96005977	HBS038
91118404	GL391	93172423	EB5541	94159261	JC336	94840023	NJ001	96008902	BL650
91120283	NJ336	93174527	AG9590	94172341	JN776	94840065	KJ722	96010048	JC759
91120284	NJ336	93176980	CE5930	94200715	JN191	94840104	JC116	96014480	NF817
91120287	NJ337	93176982	CG9590	94201043	BD360	94840602	JE015	96016489	BG450
91125494	DL391	93177186	AE5950	94202692	DD363	94843783	BL740	96020124	HR599
91151559	DY251	93177249	AD5800	94207284	HA313	94843886	JN356	96026579	JN758
91151626	DY251	93177250	AD5810	94207913	GD363	94843893	GL742	96026976	BR780
91174299	HBS447	93177251	AD5820	94210402	JC060	95100257	HR599	96026977	BR790
91174357	HBS447	93177255	JM5259	94211865	BD360	95493120	BG450	96028464	JC415
91355131	BY370	93177284	NA5230	94211881	GD363	95493121	BG540	96033224	HBS115
91358945	HL728	93177290	CD5800	94212236	GD363	95493122	BF600	96034899	JD230
91460071	BW680	93177310	HR5088	94213636	DD363	95493998	BG450	96035354	JC750
91460089	BW690	93177328	JD5411	94213809	BM490	95494183	BG540	96036554	NF825
91460097	BW700	93177329	JD5412	94214912	NJ323	95494600	JE651	96041703	BS730
91462622	JA5037	93177335	JD5413	94214985	JN634	95495466	NF778	96042653	JJ283
91462663	JA5038	93177338	KK5646	94216107	NJ679	95495497	BL830	96051581	JN579
91503348	BH950	93177701	NA5223	94216869	BD360	95496879	NF809	96055143	BM740
91503884	BF290	93177868	CE5950	94219640	GD363	95539522	GF053	96059992	HBS408
91503885	BH950	93177869	CH5030	94219642	DD363	95542218	BG450	96059994	HBS087
91505109	BL650	93178490	CD5840	94219643	DD363	95542219	BG540	96061328	BV150
91505110	BL650	93180240	AE5930	94221022	JC429	95543282	GH930	96061330	BV160
91505500	JC415	93180282	AE5920	94221025	JC284	95552708	GF054	96061591	HBS407

OE reference	▲ Payen	OE reference	▲ Payen	OE reference	▲ Payen	OE reference	▲ Payen	OE reference	▲ Payen
96062536	BS810	97253297	AG9780	98472023	AN450	0109970947	NB973	0199971947	NB973
96065269	NF814	97263015	JD5331	98472291	JN596	0109973347	NB973	210119070	JH881
96073848	HBS084	97313266	JD5330	98472333	AN370	0109973447	NB971	0219971847	NA5131
96075122	BL650	97315052	AE5520	98480250	BE580	0109976147	NC065	234032234	KJ779
96080067	NA5205	97315053	AE5530	98482291	AY310	0109978947	NB971	234032235	KG664
96080792	NA5204	97315054	AE5540	98482940	NF853	0109979047	NB974	0239973147	NA5248
96093134	BS820	97370797	AE5520	98484659	KD931	210111003020	BH700	0239978447	NA5131
96103003	AB5230	97370798	AE5530	98484809	JH901	111294206	CG5920	310620315	HR800
96105057	JC991	97370799	AE5540	98489690	JD229	111501237	NA380	310620353	HR800
96129692	BS810	97506647	HR805	98492150	DS381	111898200	JN579	321501641	NB567
96132009	BS730	97510801	NF870	98492152	DR073	113028540	HR805	321501641A	NB567
96133146	BL650	97510802	NF746	98492580	AY290	113101481A	JM986	322115100	JC140
96133360	BS820	97511321	JB837	98492581	AY300	113101481F	JM986	357501641B	NB567
96136745	HBS125	97520610	BS810	98498291	AY310	114029010	HBS173	360720970	JC251
96144620	HM5226	97523053	JN658	98499494	AN110	114029011	HBS173	401493730	HC375
96160677	BV140	97530738	JC702	98499495	AN110	114029012	HBS173	0411101020	GL742
96177786	JB830	97531278	HR599	99425767	JC054	114092801	JM5285	0411110030	GN530
96177787	JB864	97531974	BN580	99430005	BX390	114092852	BT580	0411110031	GN530
96181218	BZ300	97531988	HR646	99432353	BX400	0119970447	NB974	0411111020	GN200
96181823	BS730	97532964	KG5012	99432354	BX390	0119970647	NB974	0411111021	GN200
96190676	BY310	97599116	PA850	99432807	LC281	0119972247	NB978	0411111051	GN201
96325170	AG7990	98400776	KA499	99432808	LC282	0119978846	NB775	0411111130	GV330
96325175	JM5302	98410475	AB5100	99433965	NP067	0124191000	GW420	0411113022	GD952
96350469	JD5794	98410476	AY590	99436990	KD932	0126902103	JH683	0411113023	GD952
96351213	HM5227	98414010	JJ549	99442635	AN450	126907123	JM448	0411113026	GD955
96352281	JD5740	98421263	JR580	99442951	HBS255	131510403	KV086	0411113030	GD955
96352947	JD5774	98421265	LS858	99443512	KV927	131512408	KV102	0411113031	GD955
96353002	JM5303	98421269	KV927	99447458	NF883	135510271	AJ630	0411113032	GD955
96353035	NA5164	98421275	LS859	99453418	NF883	135690108	JE442	0411113033	GD955
96353036	JE5034	98421295	KA547	99458402	BX420	136310171	BE360	0411113040	GR270
96353096	JE5034	98421304	KA546	99460983	BX410	136310271	BE360	0411113041	GR270
96378802	AG8000	98424150	JN585	99461498	AY580	136311399	NJ330	0411113042	GR270
96378805	JD5739	98425767	JC054	99461499	AY590	136399100	GE360	0411115030	GL340
96391435	BZ300	98427939	JJ100	99462206	JJ549	136399100A	GE360	0411115031	GL340
96411866	JN808	98427998	NP067	99462588	JP069	136399100B	GE360	0411115040	GL341
96411875	JN812	98428409	NP068	99468744	NF883	136399101	DE360	0411115041	GL341
96411878	JJ451	98429617	KK5004	99477116	GX410	0139976847	NB971	0411115060	GL343
96411879	JJ452	98430478	KA547	99477117	GX391	143204202	HBS160	0411115070	GL341
97002474	HBS039	98431958	AN450	99477119	DX390	145610235	JN595	0411116022	GN390
97044731	AB5010	98432857	LS856	99477120	DX390	145610236	JN595	0411116023	GN390
97044732	AB5020	98432884	LS857	99478460	ET750	145610271	AJ630	0411116030	GL741
97044733	AB5030	98434020	JC055	99481359	AY660	145699100	FJ631	0411116031	GL741
97066198	AD5400	98436545	NF853	99482736	LC280	145699100E	FJ631	0411116032	GL741
97142110	AY900	98445099	AB5110	99486691	AY660	145699100F	FJ631	0411116040	GL742
97142111	AY910	98446492	JJ533	99487487	GX410	145699101	CJ631	0411116041	GL742
97142112	AY920	98448287	AN450	99488483	JJ100	0149971647	NB978	0411116070	GN390
97183007	JM5197	98448817	AB5110	99488486	JJ533	155253115	JE5076	0411116071	GN390
97218651	JD5332	98451055	NP068	0099973547	NB971	161253115	JE160	0411116072	GN390
97219444	JD5329	98454039	NP067	0099974547	NB975	161253115A	JE160	0411116073	GN390
97232207	JD5336	98454041	NP067	0099978547	NB975	171253115	JE160	0411116074	GN390
97232208	JD5333	98454045	NP067	0099978947	NB973	171253117	JE160	0411116080	GP531
97240455	JD5334	98454057	NF853	0400100020000	NF539	0179977447	NB974	0411116090	GP530
97252689	JM5198	98461673	NF885	101267300	AC5500	189971947	NB974	0411116110	GR900
97253294	AG9810	98471333	LC280	104012020	CC5520	0189975247	NB973	0411116111	GR900
97253295	AG9820	98471766	BR070	104035904	AG5610	0189977947	NC065	0411116112	GR900
97253296	AG9770	98472006	AN450	108005804	AG5600	191253115F	JE160	0411116130	GR750

INTERCHANGE OE → PAYEN

Vergleichsliste OE → Payen • Références croisées 1ère Monte → Payen
Intercambio entre equipo original y Payen

OE reference	▲ Payen	OE reference	▲ Payen	OE reference	▲ Payen	OE reference	▲ Payen	OE reference	▲ Payen
0411116131	GR750	0411131033	FJ911	0411154082	GW801	0411174041	GR330	0411216022	DN390
0411116161	GR751	0411131034	FJ911	0411154083	GW801	0411174042	GR330	0411216023	DN390
0411116171	GR751	0411133011	FJ960	0411154093	GW950	0411174050	GR250	0411216024	DN390
0411116190	GR901	0411133012	FJ960	0411154093HS	DW950	0411174051	GR250	0411216040	DL742
0411117060	FF5800	0411134010	FJ960	0411154103	GW800	0411174060	GS060	0411216041	DL742
0411121040	FB5750	0411134030	FJ960	0411155030	FG7570	0411174061	GS060	0411216042	DL742
0411122010	FJ290	0411134061	FJ962	0411156050	GR951	0411174062	GS060	0411216070	DN390
0411122011	FJ290	0411134062	FJ962	0411158010	GJ740	0411174210	GS970	0411216071	DN390
0411122182	FB5760	0411134080	FJ962	0411158011	GJ740	0411174592	FD5330	0411216072	DN390
0411123040	FD5380	0411134090	FJ962	0411158012	GJ740	0411175010	GW560	0411216080	DP531
0411124011	FJ290	0411135020	GJ660	0411158013	GJ740	0411175011	GW560	0411216090	DP530
0411124012	FJ290	0411135021	GJ660	0411158020	GJ741	0411175030	GX060	0411216100	DN392
0411124020	FJ292	0411135022	GJ661	0411158050	GJ742	0411176070	GS870	0411216110	DR900
0411124021	FJ292	0411135030	GM880	0411161010	GC260	0411187108	GR880	0411216130	DR750
0411124022	FJ290	0411135050	GM881	0411161011	GC260	0411187109	GR880	0411216131	DR750
0411124023	FJ290	0411135060	GM881	0411161012	GC261	0411187111	GR880	0411216161	DR751
0411124024	FJ292	0411135070	GM881	0411161013	GC261	0411187112	GR880	0411216190	DR901
0411124026	FJ292	0411135420	GM883	0411161020	GC260	0411187116	GR880	0411216191	DN390
0411124030	FJ292	0411136010	FJ960	0411161040	GC264	0411187123	GR880	0411216230	DV370
0411124032	FJ292	0411136011	FJ962	0411161050	GC265	0411187208	GR140	0411216260	DV370
0411124040	FJ292	0411136012	FJ962	0411163021	GK671	0411187212	GR140	0411216270	DV360
0411124041	FJ292	0411136020	FJ960	0411164040	FB5000	0411187315	GM901	0411216280	DV360
0411124042	FJ292	0411136030	FJ962	0411164050	GR581	0411187316	GP560	0411217060	CF5800
0411124043	GD950	0411136062	FJ962	0411164051	GR581	0411187317	GM901	0411221040	CB5750
0411124044	GD950	0411137031	GK700	0411164052	GR581	0411187318	GP560	0411222010	CJ290
0411124052	FJ292	0411137061	GK701	0411164053	GR581	0411187322	GM902	0411222020	CJ290
0411126023	GC993	0411142020	GR300	0411164070	GR581	0411187327	GP561	0411222060	CB5760
0411126026	GC993	0411142021	GR300	0411164071	GR581	0411187338	GP565	0411222182	CB5760
0411126027	GC993	0411142022	GR300	0411164072	GR581	0411187339	GP564	0411223040	CD5380
0411126029	GC993	0411142023	GR300	0411164111	GX010	0411187757	GR670	0411224020	CJ292
0411126040	GC993	0411142030	GR301	0411164293	FG7650	0411187769	GR760	0411224021	CJ292
0411126041	GC993	0411143040	GK461	0411165010	GS360	0411187779	GS430	0411224026	CJ292
0411126051	GC993	0411143050	GK461	0411166051	FF5790	0411196110	GE392	0411224030	CJ292
0411126053	GC993	0411143051	GK461	0411166053	FF5790	0411196111	GE392	0411224040	CJ292
0411126070	GC993	0411148011	GE392	0411166054	FF5790	0411196112	GE392	0411224041	CJ292
0411126071	GC993	0411148012	GE392	0411168010	GK930	0411196150	GP650	0411224042	DD950
0411126080	GC993	0411148013	GE392	0411168020	GR570	0411196601	GK940	0411224043	DD950
0411126090	GC993	0411148014	GE392	0411168030	GR890	0411197206	FG5920	0411226022	DC993
0411127022	GC993	0411148015	GE392	0411170061	GT630	0411202060	CG5490	0411226025	DC993
0411127034	GD061	0411148016	GE392	0411172010	GL820	0411210020	DN530	0411226026	DC993
0411127050	GD061	0411150021	FG7630	0411172011	GL820	0411211010	DN200	0411226027	DC993
0411127051	GD061	0411150112	FF5030	0411172012	GL820	0411211020	DN200	0411226028	DC993
0411128011	GC993	0411150120	FF5860	0411172013	GL820	0411211100	DV330	0411226040	DC993
0411128012	GC993	0411150121	FF5860	0411173010	GL820	0411213010	DD951	0411226041	DC993
0411128013	GC993	0411150122	FF5860	0411173011	GN640	0411213011	DD951	0411226042	DC993
0411128014	GC994	0411154042	GL951	0411173012	GN640	0411213012	DD955	0411226051	DC993
0411128015	GC994	0411154044	GL951	0411173020	GN640	0411213020	DR270	0411226053	DC993
0411128016	GC994	0411154045	GL951	0411173021	GN640	0411213023	DD952	0411227022	DC993
0411128017	GC994	0411154050	GL950	0411173040	GP650	0411214020	DG690	0411227032	DD061
0411128018	GC993	0411154051	GL950	0411173041	GP650	0411214030	DM871	0411227033	DD061
0411128070	FF5781	0411154052	GL950	0411173042	GP650	0411214031	DM871	0411227071	CG7490
0411128071	FF5781	0411154053	GL950	0411174030	GR332	0411214040	DM871	0411227090	CG7491
0411130540	FF5980	0411154054	GL950	0411174031	GR332	0411215030	DL340	0411228011	DC993
0411131030	FJ912	0411154070	GT130	0411174032	GR332	0411215070	DL341	0411228012	DC993
0411131031	FJ911	0411154080	GW801	0411174033	GR332	0411216020	DN392	0411228013	DC993
0411131032	FJ911	0411154081	GW801	0411174040	GR330	0411216021	DN392	0411228014	DC994

OE reference	▲ Payen	OE reference	▲ Payen	OE reference	▲ Payen	OE reference	▲ Payen	OE reference	▲ Payen
0411228015	DC994	0411254031	DL951	0411272010	DL820	411605500	JJ389	500366528	DX391
0411228016	DC994	0411254032	DL951	0411272011	DL820	411605600	JJ389	500366848	FY690
0411228018	DC993	0411254033	DL951	0411272012	DL820	0412160010	JJ023	500369188	KK5599
0411228052	CF5840	0411254040	DL950	0411272013	DL820	0412160061	JJ023	500369482	FY691
0411228053	CF5840	0411254041	DL950	0411273010	DL820	412305400	BL280	500369483	CY680
0411228054	CF5840	0411254042	DL950	0411273011	DN640	412305500	BL280	500376626	JY5337
0411228055	CF5840	0411254060	DT130	0411273020	DN640	412305600	BL280	500378462	KK5598
0411228056	CF5840	0411254071	DW801	0411273021	DN640	412305700	BL280	500383471	AB5720
0411228060	CF5780	0411254072	DW801	0411273030	DP651	412306102	BP730	500383472	AB5730
0411228061	CF5780	0411254101	BW800	0411273031	DP651	412306112	BP730	500383473	AB5740
0411228070	CF5781	0411255030	CG7570	0411273040	DP650	412306202	BP730	500387067	AB5720
0411230070	CF5980	0411256040	DR951	0411273041	DP650	412307022	BM340	500387068	AB5730
0411231031	CJ911	0411256041	DR951	0411274010	DL350	412307202	BG740	500387069	AB5740
0411231032	CJ911	0411258010	DJ740	0411274030	DR332	412307212	BG740	500391047	AY700
0411231033	CJ911	0411258011	DJ740	0411274031	DR332	412307222	BG740	1950501704000	JD017
0411231034	CJ911	0411258012	DJ740	0411274032	DR332	412605500	JN729	504017372	JJ613
0411231041	BX020	0411258013	DJ740	0411274040	DR330	412777000	KJ462	504018307	JH5077
0411233010	CJ960	0411258020	DJ741	0411274041	DR330	422215400	JC967	504018342	JH5081
0411233011	CJ960	0411258021	DJ741	0411274050	DR250	422215500	JC967	504019494	JM5201
0411233021	CG7600	0411258040	DJ742	0411274060	DS060	0428255000	JR635	504031409	NF885
0411234010	CJ960	0411258041	DJ742	0411274061	DS060	0428449300	BH680	504034832	NF856
0411234020	CJ960	0411261010	DC260	0411274210	DS970	431253115A	JE689	504037859	JD5338
0411234051	CJ960	0411261011	DC260	0411274240	DS061	432253115A	JE689	504049360	FB5720
0411234060	CJ960	0411261040	DC264	0411274562	CD5330	433253115	JE138	504049362	CB5720
0411234062	CJ960	0411261050	DC265	0411275010	DW560	0482401005	HR805	504052452	JM5202
0411235040	DM881	0411261053	DC265	0411275011	DW560	0483242118	KG664	504059361	NF883
0411235050	DM881	0411262040	DS292	0411275030	DX060	486910602	NJ367	504093499	AG6060
0411235060	DM881	0411263010	DK670	0411276070	DS870	0490172008	NA5001	504093500	AG6050
0411235420	DM883	0411263020	DK670	0411287106	DR880	497123005	GP731	504093501	AG7300
0411236010	CJ960	0411264010	DL300	0411287107	DR880	497123013	GR561	550421303	JJ126
0411236020	CJ960	0411264011	DL300	0411287110	DR882	497123013HS	DR561	550621303	JN415
0411236030	CJ960	0411264050	DR581	0411287114	DR881	497123051	GL280	550621305	JN415
0411237031	DK700	0411264051	DR581	0411287120	DR883	497123051HS	DL280	552142160	HBS465
0411237061	DK701	0411264052	DR581	0411287204	DR140	497123056	GL281	0555348700	BF350
0411242020	DR300	0411264061	DX010	0411287311	DM900	497123057	GP730	0555497400	JN248
0411242021	DR300	0411264070	DR581	0411287312	DM901	497123057HS	DP730	0555565700	JN251
0411242022	DR300	0411264071	DR581	0411287313	DM900	497123058	GP731	0578785600	NF746
0411242023	DR300	0411264080	DR580	0411287314	DM901	497123058HS	DP731	0580656900	HC375
0411242030	DR301	0411264081	DR580	0411287315	DP560	497123059	GR560	602828510	BW410
0411243040	DK461	0411264082	DR580	0411287316	DM902	497123059HS	DR560	0605028930	NB696
0411243041	DK461	0411264086	DX020	0411287322	DP561	10500150800	AF370	0605029100	JAB98
0411243050	DK461	0411264242	CD5340	0411287323	DP565	10500150803	AF370	0605029530	KV123
0411243051	DK461	0411264271	CD5340	0411287324	DP564	500306170	AY680	605030780	KV124
0411246063	CF5850	0411264272	CD5340	0411287720	DS431	500306171	AY690	0605041100	HR805
0411246064	CF5850	0411265010	DS360	0411287725	DN250	500306172	AY700	0605066360	JD223
0411246094	CG8300	0411266030	CF5792	0411287726	DM450	500314225	NF883	0605071070	NA5066
0411248011	DE392	0411267024	CG5540	0411287735	DS432	500315684	NF885	0605071720	JC928
0411248012	DE392	0411268010	DK930	0411287740	DR670	500316112	JJ613	0605075570	HR646
0411248013	DE392	0411268011	DK930	0411287745	DS432	500317403	JN956	0605075760	JD015
0411248014	DE392	0411268020	DR570	0411287750	DS432	500327440	JH5002	0605129200	JD016
0411250021	CG7630	0411268021	DR570	0411287752	DR760	500347039+500347040	HBS251	0605129480	JN808
0411250112	CF5030	0411268030	DR890	0411287753	DS430	500350049	NA5201	0605129490	JN807
0411250120	CF5860	0411268031	DR890	0411296110	DE392	500354411	CY680	0605133160	JN812
0411250121	CF5860	0411270010	DK680	0411296111	DE392	500366171	GX390	0605149100	BP990
0411250122	CF5860	0411270011	DK680	0411296112	DE392	500366181	DX400	0605149100+E4450	BP990
0411254030	DL951	0411270061	DT630	0411296601	DK940	500366511	GX390	0605155010	KD383

INTERCHANGE OE → PAYEN

Vergleichsliste OE → Payen • Références croisées 1ère Monte → Payen
Intercambio entre equipo original y Payen

OE reference	▲ Payen	OE reference	▲ Payen	OE reference	▲ Payen	OE reference	▲ Payen	OE reference	▲ Payen
0605155020	JR349	806730110	NJ313	0928907002	PA096	1021421480	JD292	1105860005	HR754
0605156280	JE442	806738040	NJ022	0928907005	PA305	1021421580	JD293	1110057810	CG5510
0605156890	JM669	806738070	NJ341	0928970005	PA305	1024198503	BW420	1110057811	CG5510
0605212930	NB814	806738100	NJ846	948103384B	HBS024	1029900810	HBS146	1110057812	CG5510
0605215900	KA350	806757013	NJ376	0948350523	NF096	1030100180	HL657	1110058810	CG5510
605226920	JN581	806768060	NK243	0948350580	NF334	1030100280	HL657	1110060811	DS600
0605349870	BW310	806770011	NJ342	953080413	NF634	1030105420	HL657	1110060821	DS600
0605349880	BW300	806770012	NJ342	961494980	NA5191	1030140422	JJ491	1110061810	DT900
0605359490	HR660	806770013	NJ342	0980665900	HC375	1030160221	JN623	1110061820	CG5470
0605484480	BT340	806776010	NJ343	982801158	NJ306	1030160421	HL657	1110061840	DN484
0605487510	BT380	806776011	NJ343	0990664400	DH681	1030161920	BN740	1110073818	DE550
0605525770	BW410	807210155	KJ468	860996480339	NB775	1030162120	BN740	1110077850	CG5710
0605663950	BW280	807223095	KJ468	0996701127	NF539	1030500058	HR760	1110078830	DM910
605670190	AN300	807223095A	KJ468	101000150803	AF240	1030500158	HL657	1110080810	DL390
0605698950	BW310	811253115B	JE904	101000150807	AF240	1040100630	JM5113	1110080811	DL390
605699002	BW260	811606100	JH050	11001260662	EX932	1040101920	CE5331	1110080812	DL390
0605818460	AN350	812499100	EJ653	11001287579	EX934	1040102020	CC5520	1110080818	DL390
0605918100	BE620	812608600	JM065	1010106025	EJ491	1040103220	CE5330	1110082810	DM740
0607091710	AF240	812774110	KJ462	1010123028	EJ051	1040103620	CE5331	1110082812	DM740
0607100500	JH526	812777000	KJ462	21011000001	FX660	1040103720	CE5330	1110082813	DM740
0607154800	LT726	817199101A	CJ127	21011003270	JM077	1040150120	JR5040	1110082814	DM740
0607328120	JD025	817310155	KJ710	21011005155	KT639	1040160021	JM5115	1110082821	DN480
0607508250	DP990	817310155A	KJ710	21011007026	HR363	1040160321	JM5113	1110082822	DN480
0607550160	BE620	822118600	JC140	21011009070	JH881	1040160821	JM5114	1110082823	DN480
701349529	HR300	210831003020	BS630	21011106170	KT446	1040161620	AC5520	1110082824	DN480
702246562	NF369	210831008081	JC872	21011106172	KS830	1040162820	AE5330	1110082825	DN480
702246877	JN248	831199100	GE541	21011203020	JE390	1040500258	HR5055	1110082826	CG5470
702607235	JE648	831199100A	GE541	1020101180	EH872	1041411080	JD167	1110083810	CG5470
702672445	NF634	832599100	GE541	1020103305	EH872	1041420380	JD169	1110083812	CG5470
702673237	BH680	832599100A	GE541	1020103405	EH872	1041420780	JD169	1110083813	DN481
702677832	HC354	838599101	CJ127	1020103505	EH881	1047533851	BW680	1110083814	CG5470
703328000	KJ647	841253115B	JE904	1020106141	DH873	1049900012	HBS152	1110083815	CG5470
0706305500	HBS104	843253115	JE904	1020106241	DH882	1051401507	JP004	1110083816	CG5470
712000740	HBS189	210846602446	GS620	1020106641	DH872	441054074216	BT580	1110084818	DM912
90750670661	KJ647	210846602447	DS620	1020107741	DH873	441054074406	BT580	1110085820	DL391
752327107	JH5103	0854898300	NF369	1020107841	DH882	1054101601	JA840	1110086822	DN482
770010744	HBS241	0855483900	BH680	1020107941	DH870	441054151716	HR599	1110100430	HM5057
770083008	HBS120	856622900	HC375	1020108241	DH872	101060160900	KV004	1110102820	DV810
770658325	HR643	856622900	HC375	1020140722	JJ488	1060162720	BH870	1110102920	DV820
770733041	BN360	856910271	BE540	1020160321	JN454	101060411000	KD383	1110103108	EV810
770738986	HBS102	856910271A	BE540	1020160421	JN454	21081007026	HR805	1110103820	DZ160
771461245	EF380	0857720800	JB855	1020160520	BH870	1096253200	NJ646	1110103920	DZ160
210801003020	BS620	857999100A	GE541	1020160521	JN607	1100100830	HL659	1110104120	DZ900
210801009070	JJ412	891499100	GE541	1020160620	BH870	1100109508	EC821	1110105020	DZ881
802099100A	GE541	894179391	HC5008	1020161121	JN454	1100160321	PB256	1110105120	DZ891
802099100B	GE541	90900952497	NF185	1020161221	JN607	1100500067	HR754	1110106220	DZ881
802899100	EJ651	0928332003	NJ336	1020162220	BH870	1104221025	CJ051	1110106420	DZ891
802899100A	EJ652	0928332016	NJ336	1020162320	BH870	1104221026	CJ051	1110140022	JJ499
802899100B	EJ652	0928332022	NJ336	1020162420	BH880	1104421001	AJ490	1110140122	JJ499
802899100C	EJ652	0928332025	NJ336	1020162520	BH880	1104421003	AJ050	1110140222	JJ499
802899101C	CJ652	0928332026	NJ377	1020163220	BH880	1104421005	AJ050	11110150669	EG9000
803410271	AJ650	0928332036	NJ377	1020297000	JE442	1104440126	BW620	1110160221	JN911
803410271A	AJ650	0928360003	NJ337	1020500058	HR757	1104461512	BJ360	1110160420	BZ900
803410271B	AJ650	0928360005	NJ337	1020500067	HR756	1104461513	BJ360	1110160620	BZ900
803499100	EJ653	0928368001	NJ378	1020500158	HR756	1104461514	BJ360	1110160720	BZ850
806730021	NJ252	0928905012	HR5075	1021413480	JD291	1104490003	BJ360	1110160721	JM5111

OE reference	▲ Payen	OE reference	▲ Payen	OE reference	▲ Payen	OE reference	▲ Payen	OE reference	▲ Payen
1110160921	JN911	1111516050	BP530	1111534030	AJ960	1111562030B	BS290	1111587727	BR670
1110161220	BZ900	1111516070	BR900	1111535010	BJ660	1111563010	BK670	1111587728	BR670
1110161221	JN911	1111516080	BR750	1111535011	BJ660	1111563011	BK670	1111587729	BS430
1110161320	BZ850	1111516081	BR750	1111535020	BM880	1111564010	BL300	1111587732	BS090
1110161420	BZ880	1111516082	BR750	1111535030	BM880	1111564050	AB5000	1111588301	BM480
1110161520	BZ900	1111516090	BR750	1111535040	BM880	1111564060	BR580	1111588360	BR330
1110161620	BZ890	1111516100	BR750	1111535060	BM880	1111564080	BR580	1111588361	BR330
1110161720	BZ890	1111516130	BV370	1111536010	AJ960	1111564100	BR580	1111588362	BR330
1110162420	BZ850	1111516150	BV370	1111536020	AJ960	1111564110	BR580	1111588380	BS060
1110162620	BZ880	1111520010	BZ340	1111537010	BK700	1111564121	BR580	1111588381	BS060
1110162720	BZ880	1111521030	AB5750	1111537020	BK700	1111564122	BR580	1111588382	BS060
1110162820	BZ900	1111522010	AJ290	1111537021	BK700	1111564180C0	AG5240	1111620010	BZ350
1110162920	BZ890	1111522020	AJ290	1111540060	AG9310	1111565020	BS360	1111650011	AG7630
1110163020	BZ890	1111522031	AB5760	1111542020	BR300	1111566020	AF5790	1111650040	AF5860
11110394505	EC5410	1111522040	AB5760	1111543030	BK460	1111566030	AF5790	1111662030	BS300
1111000400	CE602	1111522050	AB5760	1111545030	BD760	1111568010	BK930	1111662030B	BS300
1111020000	CF070	1111523030	AD5380	1111545040	BD760	1111568011	BK930	1111662071	BY460
1111410480	JD160	1111523041	AG9830	1111546040	AF5850	1111568020	BR570	1111662080	BY460
1111410680	JD160	1111523042	AG9830	1111546045	AG5100	1111568030	BR890	1111665020	BS370
1111410780	JD160	1111524010	AJ290	1111548020	BK910	1111568040	BR570	11111712981	EB5660
1111410880	JD5226	1111524011	AJ290	1111548021	BK910	1111568050	BR890	11111740981	EY571
1111411280	JD5226	1111524012	AJ290	1111548023	BE390	1111570010	BK680	1112121000	JH005
1111420380	JD161	1111524013	AJ290	1111548024	BE390	1111570020	BK680	1112161500	JJ151
1111420580	JD161	1111524015	AJ290	1111548025	BE390	1111570030	BM480	1112161501	JJ151
11111432478	EW802	1111526023	BC990	1111548028	BE390	1111570060	BT630	1112161502	JJ151
11111485171	NA5139	1111526024	BC990	1111548030	BK910	1111571010	BL820	11112243888	EX934
11111492244	NA5140	1111527010B0	AG7480	1111550021	AG7640	1111571011	BN640	11112244327	EW730
1111510010	BN530	1111527010C0	AG7490	1111550042	AF5030	1111573010	BP650	11112245749	EY280
1111510020	BN530	1111527010D0	AG7500	1111550050	AF5870	1111573040	BL820	11112246703	EY270
1111510040	BN530	1111527010E0	AG7510	1111554020	BL950	1111574010	BL350	11112247511	EZ800
1111511010	BN200	1111528010	AF5840	1111554021	BL950	1111574010N	BL350	11112248975	EZ660
1111511020	BN200	1111528012	AF5840	1111554030	BT130	1111574020	BL350	11112248976	EZ690
1111511030	BN200	1111528020	AF5780	1111554070	BW950	1111574030	BR250	1114173000	BE550
1111511060	BN200	1111528021	AF5780	1111554071	BW950	1111574060	BW460	1114173001	BE550
1111511070	BV330	1111528022	AF5780	1111554072	BW950	1111574070	BS970	1114173002	BE550
1111511071	BV330	1111530031A0	AG7520	1111554073	BW950	1111574080	BS970	1114173003	BE550
1111511080	BV330	1111530031B0	AG7530	1111554073F0	BW950	1111574090	BS060	1114175101	BL390
1111513010	BD950	1111530031C0	AG7540	1111554080	BW800	1111574100	BL350	1114175102	BL390
1111513030	BD950	1111530031D0	AG7550	1111554081	BW800	1111574101	BL350	1114176001	BH740
1111513031	BD950	1111530031E0	AG7560	1111554082	BW800	1111574110	AD5330	1114178400	BM910
1111513040	BR270	1111530040A0	AF5980	1111554083	BW800	1111575010	BW560	1114178401	BM910
1111514030	BM870	1111530040B0	AF5981	1111554084	BW800	1111575020	BX060	1114178402	BM910
1111514030B	BM870	1111530040C0	AF5982	1111554120B0	AY800	1111576030	BS870	1114179100	BP780
1111514031	BM870	1111530040D0	AF5983	1111556030	BR950	1111587105	BR880	1114182000	BM740
1111515020	BG670	1111530040E0	AF5984	1111556050	BR950	1111587106	BR880	1114182001	BM740
1111515021	BG670	1111531020	AJ910	1111556060	BR950	1111587208	BR140	1114182011	BM740
1111515030	BG670	1111531021	AJ910	1111556130	BR950	1111587307	BM900	1114182600	BN480
1111515031	BL340	1111531022	AJ910	1111558010	BJ740	1111587308	BM900	1114182601	BN480
1111515041	BG670	1111531023	AJ910	1111558011	BJ740	1111587309	BM900	1114182602	BN480
1111515042	BG670	1111533010	AJ960	1111558012	BJ740	1111587312	BM900	1114182611	BN480
1111515050	BL340	1111533011	AJ960	1111558040	BJ740	1111587701	BJ630	1114186501	BN480
1111515060	BL340	1111533021C0	AG7600	1111558050	BJ740	1111587703	BJ630	11117508543	EC5921
1111515061	BL340	1111533021D0	AG7610	1111558110	BJ740	1111587709	BM450	11117548101	EG9540
1111515120	BV360	1111533021E0	AG7620	1111561010	BC260	1111587717	BR670	1117582245	HM5278
1111516020	BL740	1111534010	AJ960	1111561020	BC260	1111587723	BS090	1118973000	JN414
1111516030	BN390	1111534020	AJ960	1111562030	BS290	1111587724	BR760	1118973001	JN414

INTERCHANGE OE → PAYEN

Vergleichsliste OE → Payen • Références croisées 1ère Monte → Payen
Intercambio entre equipo original y Payen

OE reference	▲ Payen	OE reference	▲ Payen	OE reference	▲ Payen	OE reference	▲ Payen	OE reference	▲ Payen
1118978100	JN440	11121277311	DC935	1121362020	JN792	11121721336	DR830	11121734279	BC920
1118978101	JN854	11121277779	DL690	1121363010	JN469	11121721475	JP032	11121734280	BP610
1118982600	JN606	11121278300	BC920	1121363011	JN469	11121721476	JP077	11121734624	JP079
1118986500	JN682	11121278303	BC940	1121364020	JN532	11121721495	BR830	11121736113	JM5109
11119059257	ER830	11121278305	BL680	1121364040	JN532	11121721546	BY560	11121736114	JM5108
11119063134	EX932	11121278306	BL690	1121365010	JN712	11121721547	BY560	11121736115	JM5107
11119064460	ET681	11121285609	NB799	1121366021	HM5240	11121721875	JP077	11121736315	BX270
11119066462	EW730	11121285620	NB799	1121368010	JN536	11121721876	JP027	11121736316	BX280
11120004553	CC5350	11121285973	JN578	1121368020	JN705	11121721938	HBS068	11121736317	BX270
11120028033	HM5160	11121286335	DD631	1121371020	JN551	11121721939	HBS069	11121736318	BX280
11120030496	HM5069	11121287450	BR420	1121374010	JN630	11121722021	HBS041	11121736319	BX290
11120031987	HM5150	11121287451	BR430	1121374020	JN655	11121722388	JN297	11121736340	BX300
11120032224	HM5160	11121287452	BR440	1121376020	JN771	11121722389	JN542	11121736341	BX290
11120141055	CC5901	11121287578	DR422	1121387103	JN700	11121722390	JN297	11121736342	BX300
11120143667	CC5441	11121287686	BL690	1121387203	JN663	11121722725	BD630	11121739331	BR830
11120147561	CC5921	11121287834	BD630	1121387304	JN405	11121722726	BR840	11121739334	BR830
11120147641	CC5921	11121287933	BC920	1121387305	JN636	11121722727	BD630	11121739849	B2130
11120150670	CG9000	11121287934	BC910	1121387307	JN699	11121722728	BD630	11121740065	HBS413
1120160120	AE5730	11121288338	BC930	1121387705	JN415	11121722729	BR840	11121740982	DY570
1120160220	AE5740	11121289933	BC920	1121387708	JN718	11121722734	BL680	11121740984	DT693
1120160221	JM5236	1121310010	JN598	1121388360	JN596	11121726478	HBS041	11121741468	AC5370
1120160231	JM5237	1121311040	JN865	1121388381	JN768	11121726617	BT690	11121741469	AC5370
1120160320	AE5750	1121315010	JN356	1121412080	JD5385	11121726618	BT690	11121741470	AC5380
1120160321	JM5237	1121315020	JN356	1121416020	JN604	11121726623	BT680	11121741471	AC5380
1120160420	AE5760	1121315021	JN356	1121416040	JN879	11121726624	BT680	11121743114	BR830
11120261144	HBS070	1121315040	JN591	1121416050	JN876	11121727726	JN698	11121743375	D2130
11121059238	DL691	1121315050	JN706	1121420180	JD5386	11121727914	BC920	11121743704	AB5660
11121255162	BC930	1121315070	JN904	11121427825	DY571	11121729246	HBS067	11121747021	JM5109
11121256919	BC940	1121316010	JN603	11121427826	DT692	11121730217	BS320	11121747022	JM5108
11121257561	BC940	1121317010	HM5241	11121432885	JP079	11121730220	BS320	11121747023	JM5107
11121257990	BC920	1121320020	HM5242	11121433463	AC5640	11121730223	BL690	11122241051	BR420
11121260673	DC929	1121321011	JM5072	11121433467	AC5650	11121730226	BL690	11122241052	BR430
11121262571	HR397	1121322010	JM025	11121433473	AC5350	11121730229	JN297	11122241053	BR440
11121262810	BC920	1121322050	JM5073	11121433477	AC5360	11121730231	JN542	11122241146	DR422
11121265108	JN297	1121323020	JM5149	11121433950	BZ130	11121730252	DR831	11122242959	BR420
11121265404	BC910	1121324010	JM025	11121435586	AC5310	11121730253	DT691	11122242960	BR430
11121265406	BC920	1121325010	JM054	11121436760	JM5096	11121730745	BC930	11122242961	BR440
11121265416	BC930	1121325011	JM054	11121436761	JM5097	11121730746	BC930	11122243143	HBS065
11121265417	BC940	1121325012	JN410	11121436822	CC5900	11121730747	BP620	11122243203	JN955
11121265420	BC920	1121328041	JM7022	11121437343	JM5098	11121730769	DC935	11122243877	DR422
11121265422	BC940	1121330020	JM7023	1121446010	HM5273	11121730780	DL690	11122243879	DR422
11121266208	BD630	1121333010	JM029	1121476010	JN772	11121730876	DD631	11122244327	EW730
11121266759	DD630	1121333021	JM5288	11121485838	JM5119	11121730934	JN300	11122244328	DW730
11121267136	JN299	1121334020	JM029	1121488360	JN629	11121730935	JN300	11122244398	JN955
11121267138	JN300	1121335010	JN185	1121488380	JN629	11121730936	JN300	11122244727	BR420
11121268816	BC910	1121336010	JM029	1121488381	JN629	11121730950	BC940	11122244728	BR430
11121268818	BC920	1121338010	JN185	11121708585	AB5660	11121733966	JM5107	11122244729	BR440
11121268849	BC920	1121342020	JN631	11121708891	BL680	11121733967	JM5109	11122244920	BW730
11121269235	BR840	1121354030	JN567	11121712309	CB5660	11121733968	JM5108	11122244921	BW740
11121269250	BC930	1121354050	JN965	11121715181	JN698	11121734030	JN299	11122245355	BZ110
11121269251	BC930	1121356010	JM068	11121715452	BR830	11121734115	DC929	11122245356	BZ120
11121269252	BC940	1121356011	JN664	11121716223	BL690	11121734213	BC920	11122245426	BZ110
11121269253	BC940	1121356012	JN664	11121716226	BS320	11121734214	BP610	11122245427	BZ120
11121269493	DC929	1121356020	JM068	11121716228	DL691	11121734215	JN299	11122245483	BW730
11121271770	DC92B	1121356030	JN827	11121718931	HBS041	11121734267	DR830	11122245484	BW740
1121276020	JN771	1121361020	JN625	11121721335	ER830	11121734276	JN299	11122245547	AY270

OE reference	▲ Payen	OE reference	▲ Payen	OE reference	▲ Payen	OE reference	▲ Payen	OE reference	▲ Payen
11122245548	AY280	11127788589	AG9020	11131713706	JH5056	1140082824	GN480	1151082600	JJ341
11122245599	JP078	11127788636	AC5300	11131722695	JJ538	1140082825	GN480	111151703001	AF5800
11122245686	JM5063	11127788640	AB5990	11131727974	JJ089	1140083810	GN481	111151703003	AF5810
11122246092	AY280	11127788642	AB5980	11131730234	JJ104	1140083811	GN481	111151703005	AF5820
11122246093	AY270	11127788651	AE5340	11131739592	JJ537	1140083812	GN481	1152973000	JJ163
11122246704	CY270	11127788652	AE5350	11131739813	JJ612	1140083813	GN481	1152973001	JJ163
11122246996	JM5118	11127788656	AE5360	11131742109	JH5115	1140083814	GN481	1152979100	JJ187
11122247029	BZ500	11127788657	AE5370	11132245174	JJ536	1140083815	GN481	1152979110	JJ187
11122247030	BZ510	11127790052	AC5410	11132247949	JH5033	1140083816	GN481	1152980000	JJ273
11122247031	BZ520	11127790053	AC5420	11137548031	JH5103	1140084821	GM911	1155130010	KV412
11122247447	JM5106	11127790054	AC5430	11139063331	JJ536	1140084824	GM911	1155131010	KV412
11122247498	BZ500	11127794495	JM5167	11139066503	JJ536	1140084824HS	DM911	111155503001	AG7570
11122247499	BZ510	11127805927	JM7034	11139067655	JJ614	1140084883	GM912	111155503002	AG7580
11122247500	BZ520	11129058467	DL681	1140052820	FG8100	1140085820	GL391	111155503003	AG7590
11122247501	DZ661	11129059238	DL691	1140060811	GS600	1140086822	GN482	111156414102	AG7650
11122247591	JM5076	11129059240	DL681	1140061822	GT900	1140177850HS	CG5710	111156414103	AG7660
11122247673	BZ690	11129059248	DD630	1140061823	GT900	1140177851HS	CG5710	111156418003	AG5240
11122247674	BZ700	11129063330	DY542	1140061824	GT900	1140177852HS	CG5710	111156418103	AG5240
11122247675	BZ710	11129063333	DY542	1140061825	GT900	1140177853HS	CG5710	111156420002	AG7670
11122247677	BZ660	11129064466	DT681	1140061850	GN484	1140177854HS	CG5710	111156420003	AG5240
11122247678	BZ670	11129064467	DT691	1140061880	GN483	1140178852	FG5130	111156702005	AG5230
11122247679	BZ680	11129065439	DY541	1140065870HS	CG5730	11141247533	JR5041	111156704005	AG5230
11122248982	BZ660	11129065554	DC92B	1140065871HS	CG5730	11141247837	JR5042	111156705005	AG5230
11122248983	BZ670	11129065638	BC940	1140065872HS	CG5730	11141255010	NB792	111157601071	BE390
11122248984	BZ680	11129065653	BC910	1140065873HS	CG5730	11141255011	NF554	1160150800	BC370
11122248985	DZ660	11129065718	DC921	1140069833	CG8180	11141255012	NB431	1160164020	BW220
11122248987	BZ690	11129066434	DY520	1140073813	GE550	11141255014	NB432	1160164420	BW220
11122248988	BZ700	11129066452	DR831	1140073818	GE550	11141255015	NF634	1163679013	CN306
11122248989	BZ710	11129067790	HBS066	1140073819	GE550	11141265431	NF637	1167601704	JD025
11122248990	DZ690	11129067792	HBS121	1140073820	GE550	11141271081	NF637	1169970246	NA5268
11122354013	AC5320	11129070058	DW731	1140073821	GE550	11141274346	NF637	1190140822	JH5113
11122354014	AC5330	11129070530	HL734	1140073822	GE550	11141275293	NB431	1190162020	AC5530
11122354015	AC5340	11129070531	HL735	1140078821	GH740	11141275466	NF637	1190162620	AC5530
1127355010	JM7024	11129070532	HL736	1140078822	GH740	11141278108	NB432	1192001508	DK572
11127501304	AC5900	11129070615	DZ130	1140078823	GH740	11141439570	NA5099	1192079010	DK572
11127501305	AF5190	11129070622	DZ121	1140078823HS	DH740	1141450830	JC336	211201252101	JM315
11127504631	BR830	11129071589	HM5066	1140078824	GH740	1141450890	JC336	91201402005	NB596
11127506983	AC5310	11129071590	HM5067	1140078825	GH740	11141706785	NB431	91203611003	NJ254
11127508543	AC5920	1129900212/13	HBS463	1140078826	GH740	11141706999	NB431	91203611004	NJ254
11127508545	CC5920	1129970046	NA5168	1140078827	GH740	11141709593	JR5031	1209970346	NB973
11127508936	HBS359	1129970246	NA5168	1140078828	GH740	11141709632	NB432	31211101114	NJ011
11127509710	AC5440	1129970346	NA5168	1140078850	DM910	11141713722	NA5267	31211106220	NF036
11127509711	AC5470	11130000686	JH5049	1140078851	GM910	11141713730	NA5132	31211119200	NJ066
11127511534	HBS467	11130000689	JH5032	1140078853	GM910	11141714617	NB980	91212611003	NJ072
11127511535	CC5440	11130139259	JH5070	1140078854	GM910	11141715100	NB792	91212611004	NJ072
11127548799	HBS468	11130607100	JJ089	1140078855	GM910	11141715101	NB792	31212634108	NF036
11127548921	CG9540	11131280901	JJ104	1140078856	GM910	11141721560	NC015	91212679003	NK102
11127555755	AG9540	11131315154	JJ538	1140080810	GL390	11141741532	JR5044	91212679004	NK102
11127555756	AG9550	11131432109	JH5050	1140080811	GL390	11141743033	JR5046	91212679014	NK125
11127555757	AG9290	11131436324	JH5116	1140080812	GL390	11142245364	NB431	91214634003	NJ073
11127557265	AH5120	11131437237	JJ611	1140080813	GL390	11142247091	JR5022	91214634004	NJ073
11127559311	HM5278	11131487221	JH5051	1140080814	GL390	11142249532	NA5105	91214634005	NJ073
11127787074	JM5167	11131702047	JH5111	1140080815	GL390	11142249533	NA5104	1215112010	JJ093
11127788072	CC5410	11131709815	JH5112	1140082821	GN480	11142249534	NA5103	1215113010	JJ094
11127788587	AG9000	11131710195	JH5056	1140082822	GN480	11147787262	LK5007	1215113011	JJ343
11127788588	AG9010	11131713705	JH5056	1140082823	GN480	1150140122	JH683	1215122010	JH018

INTERCHANGE OE → PAYEN

Vergleichsliste OE → Payen • Références croisées 1ère Monte → Payen
Intercambio entre equipo original y Payen

OE reference	▲ Payen	OE reference	▲ Payen	OE reference	▲ Payen	OE reference	▲ Payen	OE reference	▲ Payen
1215122011	JH018	11341288544	HR599	11611734401	JD283	1717215010	JC116	1717388380	JC789
1215124010	JH018	11341289948	PA815	11611734684	JD490	1717222010	JA029	1717662040	JA5058
1215124020	JH170	1341420280	JD5871	11611739545	JD608	1717224010	JB910	1717673011	JC658
1215124021	JH170	11341706580	HR599	11611740069	JD492	1717224011	JB910	1717710010	JC559
1215125010	JH041	11341706707	HR599	11612244384	JD274	1717233010	JC371	1717711010	JC559
1215130010	JH021	11342247171	PA5016	11612244391	JD274	1717234010	JC371	1717711020	JD085
1215135010	JJ322	11349059169	HR363	11612245438	JD612	1717234020	JC371	1717716010	JC578
1215138010	JJ322	11349059171	HR646	11612246944	JD5108	1717261030	JB975	1717716011	JC578
1215138020	JJ322	11349059172	HR602	11612246945	JD5107	1717261040	JB975	1717721020	JD5159
1215141010	JH024	11349063193	HR791	11617503215	HA5024	1717263010	JC402	1717723020	JD5836
1215148010	JJ250	11349065438	HR817	11617513044	JD5826	1717263020	JC402	1717725020	JB949
1215154010	JJ150	11349070982	HR5045	11617530703	HA5024	1717273010	JC615	1717725030	JB949
1215154011	JJ150	1351018000	NJ022	11617547242	JD5864	1717310020	HA397	1717725031	JB949
1215154020	JJ150	1351420280	JD5905	11617790198	JD5108	1717310021	HA397	1717727010	JD5901
1215160010	JJ023	1121387211000	JM5301	11621174968	JD5827	1717315010	JC881	1717728010	JD5170
1215160020	JJ023	1403518000	JA010	11621723832	JD071	1717315040	JD176	1717735010	JC215
1215160021	JJ023	1403518010	JA010	11621723875	JD071	1717316010	JC579	1717735011	JC215
1215161010	JJ023	1403521000	JA008	11621728981	JD561	1717321020	JD5738	1717735020	JC215
1215161011	JJ023	1403523000	JA007	11621728983	JD561	1717322010	JD5160	1717735021	JC215
1215161021	JJ023	1403561500	JC188	11621732969	JD5916	1717323010	JD5837	1717735021N	JC215
1215168010	JJ277	1403561501	JC188	11621743620	JD243	1717325010	JA053	1717735030	JC215
1215187103	JJ435	1414073000	JC222	11621743719	JD243	1717325011	JA053	1717735050	JC215
1215187702	JJ126	1414073001	JC222	11621744252	JD497	1717325012	JA053	1717742010	JC739
1227918000	NJ021	1414078100	JC242	11622243781	JD275	1717326010	JB950	1717743010	JC277
1227918001	NJ021	1414079100	JC242	11622243782	JD275	1717328010	JD5171	1717754011	JC640
1227918010	NJ021	1414079200	JC222	11622244568	JD276	1717335020	JC410	1717754012	JC640
1227921000	NJ056	1414083000	JC641	11622244569	JD276	1717335060	JC584	1717764010	JC576
1227921010	NJ056	1414083010	JC641	11622246174	JD5134	1717342010	JC276	1717774010	JC841
1227976200	LV501	1418282000	JF109	11622248287	JD5183	1717343010	JC276	1717774070	JD194
1230102720	DC820	1418382601	JF046	11627505789	JD5146	1717343020	JC276	1717787101	JD5744
1230160320	BC820	11422249532	NA5105	11627787630	JD5183	1717343030	JC276	1717787301	JD5743
1230160520	BC820	1469973000	JE735	11627806008	JD5829	1717343040	JC276	1717787706	JC938
1230160620	BC820	1469973001	JE735	1634138010	KA555	1717345020	JB983	1717788360	JC841
1234920380	JE5026	1516570010	NJ963	1634138011	KA555	1717345021	JB983	1717788380	JC841
11251657000	JH171	11531432874	KK5484	1660100014	NA5107	1717345030	JB983	1745122010	JE050
11251657010	JH171	11531721172	KK5684	1660160120	AB5550	1717347010	JC344	1745122070	KK5495
0411297401000	CG9830	11531740437	KK5520	1660160220	AB5570	1717347011	JC344	1745141020	JE037
1304218000	NJ022	11531748047	KK5682	1660180080	JM5163	1717354010	JC185	1745187705	JE146
1304232200	NJ278	11537509357	KK5484	1661400134	JD5135	1717354011	JC185	11761711717	JE5074
1304273000	NJ045	1111597201000	AG5920	1661400234	JD5135	1717354020	JC445	11896985004	NF036
1311913000	JC420	1600160120	AC5660	1661410080	JD5804	1717356020	JC439	1951708601	JC497
1311913001	JC420	1600160320	AG8990	1669970246	NA5109	1717356021	JC439	1970000000	DV150
1311973000	JC420	1601420280	JD5205	1717087301	JD5741	1717356022	JC439	102000970001	JE442
1311973001	JC420	1601420880	JD5821	1717115020	JC880	1717364020	JC399	1002000970001	JE447
1311982000	JC532	11608701300	BH850	1717115030	JD175	1717364030	JC444	102000970001	JE447
11312185916	NB775	1609970146	NA5118	1717116030	JC879	1717364050	JC444	1192001508001	DK572
111313739592	JJ537	1609970246	NA5118	1717116040	JC879	1717365020	JC838	10512015080001	AN300
1320776200	KJ452	11611247478	JD611	1717116051	JD5771	1717368010	JC409	102020970001	JE442
1320776201	KJ452	11611436631	HA5023	1717122030	JD5243	1717368020	JC409	2033300060	NA5248
1320776203	KJ452	11611437384	JD5858	1717174010	JC840	1717370010	JC545	162060150800	BK570
1327018001	JM008	11611717259	JD493	1717188360	JC840	1717374040	JD112	122060150801	BP260
1327067500	JN640	11611721344	JD283	1717188381	JC840	1717387101	JD5745	162060150801	BP260
1327076200	JM055	11611721346	JD189	1717213020	JB910	1717387301	JD5742	162060150802	BK580
11340029571	HM5061	11611721763	JD490	1717213021	JB910	1717387702	JC088	2091011600	FJ690
11341273501	HR569	11611726016	JD315	1717213030	JB910	1717387703	JC088	2091011610	FJ690
11341285249	HR569	11611730788	JC929	1717214011	JC116	1717388360	JC842	2142133114	NJ005

OE reference	▲ Payen	OE reference	▲ Payen	OE reference	▲ Payen	OE reference	▲ Payen	OE reference	▲ Payen
2142135001	NJ874	12251673000	BG710	3160102103	BE410	5022012288YX6008AA	EX480	105390150800	AF240
2144321000	NJ008	12251673004	BG710	3160102104	BE410	915035000028	PA349	105390160100	JA840
2144321010	NJ006	12251679004	BJ610	3160103016	BE410	5040815156(6)+		5410100205	EC030
2144333004	NJ251	12251679014	BJ610	3160112200	BE410	5040815318(4)+		105410160100	JA840
2145111010	JH034	12251679024	BJ610	3160115000	BE410	504081543(4)+		105410160101	JA840
2145121010	JJ098	12251689000	BE120	3160115100	BE410	5040815468(1)	HBS464	105480150800	BH850
12210689003	PA424	12251689010	BE120	3169400010	GE410	5096250150	NJ231	115500121000	JH526
12211689003	PA313	12328679000	JN404	3169400020	GE410	5096250220	NJ267	195510150800	BT350
12211689013	PA313	12328679003	JN404	3169400030	GE410	5096250280	NJ266	95510438300	AG9610
2214421010	NJ242	12328679010	JN404	3169400040	GE410	5096250360	NJ265	05555655700	JN251
2222411000	KJ211	12328679020	JN404	3169400050	GE410	5096250531	NJ321	195590970400	JD025
2222421010	KJ570	12341689000	JN318	3169400060	GE410	5096250532	NJ321	195610151300	BW280
2231102700	AG8050	12341689010	JN318	3169400070	GE410	5096250540	NJ231	5878100840	FX182
2231102760	AG9900	22410100404	NA380	03210316100K	KK5551	5096250790	NJ014	5878100841	FX182
2231102800	AG8060	2660160269	HBS457	3509977746	NB775	5096250830	NJ266	5878100842	FX182
2231111600	AJ690	2660160620	AG8500	003760040101	NB775	195100120500	JJ451	5878100843	FX182
2231121010	BE070	2660160720	AH5000	3821273000	NJ274	5111410040	BK040	5878100844	FX182
2231121100	BE070	2661410080	JD5799	154020970400	JD015	5111410170	AX180	5878101021	FX182
2231122130	BY730	2661420080	JD5802	04111064093	GX020	5111410172	AX180	5878101120	GJ650
2231123000	AG5070	2710160320	AG8790	04111064106	GX020	5111410300	BK040	5878101150	CX182
2231123100	AG8290	2710160369	HBS459	111412111000	AG8020	5111410570	BK040	5878101151	CX182
2231123700	AG8030	2710160520	AG8790	4323221000	NJ106	5111410671	BM370	5878101160	DJ650
2231126051	AG6040	2710160921	JM7026	4323278100	NJ274	5111410690	BJ650	5878101240	DM491
2231127000	AG7920	2711410880	JD5835	7700114424023717P	JH5041	5111410691	BJ650	5878101241	DM491
2231127010	AG7930	2711420380	JD5801	4751407000	NF539	5111410720	BJ650	5878101450	GJ650
2231127020	AG7940	2720160020	AG8370	604920101420	KG664	5111410721	BJ650	5878101451	GJ650
2231127500	AG7910	2720160120	AG8380	105000117600	NA5066	5111410722	BJ650	5878101452	GJ650
2231135020	AG8090	2720160420	AG8370	105000117602	NA5066	5111410731	BJ650	5878101460	GJ650
2231137210	BZ290	2720160520	AG8380	105000121003	JH526	5111410821	BM370	5878101461	GJ650
2231137220	BZ280	2720160720	AG8390	105000121007	JH526	5111410830	BK040	5878101470	DJ650
2231137310	AF5060	2720160820	AG8400	105000150803	AF370	5111730160	JN504	5878101471	DJ650
2231137320	AG5090	2720161120	AG8410	105000170400	JA829	5111730170	JN408	5878101530	DJ650
2231138100	AF5430	2720161220	AG8420	5000296030	DS381	5113670040	JH016	5878101531	DJ650
2231138200	AF5070	2720161520	AG8420	5000684700	NF837	5113670050	JJ177	5878101702	GM370
2231139501	AG7780	2720161920	AG8410	5000694362	JD319	5113670051	JJ177	5878101820	GJ653
2231139502	AG7790	2720162020	AG8420	5000694388	JD319	5113670460	JJ192	5878101821	GJ653
2232002500	HBS378	2730160620	AG8480	105000720300	KA350	5113670630	JJ376	5878101822	GJ653
2232123000	HBS478	2730160720	AG8470	5000815434	NP067	5113670631	JJ376	5878101872	GJ650
2232123010	HBS478	2730160820	AG8430	5000815452	BR070	5113670640	JJ376	5878101890	DJ654
2232127000	HBS382	2730160920	AG8440	5000824311	FY291	5113670641	JJ376	5878101891	DJ654
2232137120 (16x)	HBS446	2730161220	AG8480	5001000816	NP068	105120150800	AN300	5878101900	DJ652
2232137120 (16x)	HBS446	92810460100	HR599	5001001151	NF833	105120150801	AN300	5878101901	DJ652
2244102400	JM5306	92810460107	HR800	5001001215	HBS011	105120150805	AN300	5878102042	DM330
2244111000	JM023	2841102500	JD5900	5001001216	HBS011	5125690060	PA418	5878102070	GM491
2244121000	JN317	2841121000	JC122	5001001231	BE580	105127901000	FN307	5878102071	GM491
2244122013	JM5277	2841221000	JC123	5001001234	JN462	105140150701	JP004	5878102072	GM491
2244126001	HMS261	2852102503	JD5899	5001001254	NP067	5141450040	JC336	5878102080	GJ655
2244132000	JN496	2852121000	JC023	5001001283	JC054	5141450041	JC336	5878102082	GJ655
2244132010	HMS272	2852122020	JD5751	5001001288	KA546	5141450042	JC336	5878102163	GK044
2244135000	JN713	3034022013	HJ013	5001823706	BR070	5141460180	JC643	5878102170	GK044
2244135520	HMS264	3060422801	PA468	5001829815	AY590	195160860100	JD016	5878102171	GK044
12251634000	BC630	23111204223	NA5263	5001829882	JN594	195170160100	JC497	5878102172	GK044
12251634010	BC630	2103120302001	JE390	5001836510	GX410	195240351100	JN806	5878102450	GM491
12251634020	BC630	3131106100	NJ042	5001836511	DX391	105260150800	AF370	5878102460	DM491
12251642010	BC630	3131106101	NJ042	5001836513	DX390	195260860100	JD018	5878102461	DM491
12251642020	BC630	3150300080	NB984	5001853924	NP067	195360351101	JN812	5878102500	DP980

INTERCHANGE OE → PAYEN

Vergleichsliste OE → Payen • Références croisées 1ère Monte → Payen
Intercambio entre equipo original y Payen

OE reference	▲ Payen	OE reference	▲ Payen	OE reference	▲ Payen	OE reference	▲ Payen	OE reference	▲ Payen
5878102550	GP980	6001000550	JN369	6021410080	JD299	6060500158	HR5057	6160162020	BC790
5878102580	DM330	6001040367	BX620	6021410280	JD298	6061410080	JD478	6165860390	GC790
5878102581	DM330	116001150800	BC370	6021410680	JD298	6070140022	JH396	6165860490	DC790
5878102582	DM330	116002173003	NF539	6021410780	JD298	6070160080	JM315	6165860990	DC790
5878102610	DK502	116002173008	NF539	6021410880	JD298	6071420001	JA282	6165861290	DC790
5878102640	GN190	116003016501	JE696	6021420080	JD299	6071420080	JA282	6170100380	EC791
5878102650	DN190	6010100180	EM720	6030107320	DY601	116080150804	BH850	6170101105	EC791
5878102860	DK047	6010100280	DT540	6030140822	JJ500	116080720300	KA350	6170160180	JN273
5878102880	DR991	6010102920	DW373	6030160020	AK660	6089971246	NF539	6170160680	BC800
5878102881	DR991	6010103320	DT541	6030160221	JN851	6110100114	NA5074	6170160720	BC800
5878102900	GK047	6010103620	DW370	6030160321	JN852	6110100174	NA5074	6170160820	BC800
5878102901	GK047	6010104805	EM720	6030163220	BT550	6110100605	EC5620	6171420780	JD297
5878103192	GP920	6010104820	DW370	6031064346	JM302	6110104520	CC5620	6175860390	DC800
5878103200	GP921	6010140222	JJ498	6031164303	NA473	6110140222	JH5082	116330150800	AN300
5878103201	GP921	6010160320	BT540	6031420080	JD301	6110160121	HM5170	116367901000	FN307
5878103202	GP921	6010160420	BT540	6032022003	CF070	6110160221	HM5170	6400160321	JM7027
5878103203	GP921	6010160421	JN572	6033042383	KT005	6110160221 (4x)	HM5170	6400160720	AG8501
5878103204	GP921	6010160521	JN619	6034022002	EF075	6110160520	AC5620	6400980680	JD5800
5878103211	DP920	6010160621	DW372	6034062353	AF070	6110160620	AC5620	6401420580	JD5803
5878103212	DP920	6010160721	JN619	6035860090	EG411	6110161020	AC5620	116420160900	KV004
5878103213	DP920	6010161920	BT540	6035860190	CK663	6110161120	AC5620	6420162120	AH5020
5878103214	DP920	6010162320	BW370	6039026002	EF462	06110679010	DJ610	6420162220	AH5010
5878103215	DP920	6010162520	BW370	6039066353	AF470	6110940080	JD5378	6421420080	JD5902
5878103240	DR200	6010162920	BT540	6039900110	HBS058	6110980380	JD5379	6421421280	JE5067
5878103241	DR200	6010163320	BW370	6039900210	HBS058	6111410180	JD5377	6421421380	JE5068
5878103242	DR200	116010172000	JE696	6039900310	HBS058	6111420780	JD5380	6460160520	AD5720
5878103250	GM491	6011410280	JD158	6040100620	DZ860	0611006111679010	GJ610	6470140022	JJ543
5878103251	GM491	6011410580	JD158	6040100805	HC5005	06111679010	GJ610	6470160121	HM5274
5878103330	GP980	6011420280	JD159	6040140022	JJ498	6112010180	KA5035	6470160620	AD5720
5878103360	DP980	6011840580	KK5683	6040160221	JM5112	6112010280	KA5036	6480160320	AG8480
5878103423	GP921	16406015080001	DK570	6040160420	BZ860	6119900322	HBS292	116550117601	NA5066
5878103433	GP920	11676015080200	BK570	6040500058	HR791	6120101405	ED5720	06561900704	KJ779
5878103442	DP920	11676015080300	BK580	6040500158	HR5056	6120101820	CD5720	06561900706	KG664
5878103460	GM491	11676015080400	BK570	6041410160	JD475	6120160020	AD5720	6561911213	KJ647
5878103580	FY811	11676015080500	BP260	6041420280	JD5225	6120160021	JM7028	06562700103	NB596
5878103581	FY811	11676015080600	BK580	6050100605	EY590	6120160320	AD5720	06562710403	NF539
5878103582	FY811	6020100080	EN720	6050101220	DY590	6120500058	HR5055	06562890186	NF554
5878103583	FY811	6020104220	DW380	6050102420	DZ870	6121410180	JD5797	6600100030	JM5162
5878103590	GS435	6020104320	DN722	6050140022	JJ543	6121420380	JD5798	6600160020	AC5670
5878103884	DR991	6020105505	EN720	6050140122	JJ543	6131420380	JE5032	6601420080	JD5206
5878104070	GM491	6020106720	DW380	6050160221	JP022	6131420480	JE5032	6610103020	DW373
5878104162	DR991	6020107520	DW381	6050160420	BY590	6150160080	JM848	6680160120	AB5560
5878104560	GR990	6020140322	JJ543	6050160520	BZ870	6150162020	BG990	6680160221	JM5165
5878104562	GR991	6020160121	JN621	6050160720	BZ870	6151420580	JB162	6680160421	JM5164
5878104591	GK047	6020160221	JN622	6050500058	HR816	6151420780	JB162	6680980065	JD5834
5878105792	GR990	6020160321	JN621	6050500158	HR804	6159900112	HBS045	6681420380	JD5136
5878106481	GR990	6020160420	BN720	6051420080	JD476	6159900212	HBS045	6689900122	HBS291
5878109790	CG5500	6020162220	BW380	06051670000	JA840	6159900312	HBS045	116760150800	DK570
5878109791	CG5500	6020162320	BW380	6060101305	EY580	6160100380	EC790	116760150802	BK570
5878113193	GR991	6020162420	BW380	6060101320	DY580	6160105221	GC790	116760150803	BK580
6000057304	JN369	6020162620	BN720	6060104620	DY580	6160105506	EC790	116760150804	BK570
6000057315	JN369	6020163020	BN720	6060140022	JJ500	6160140122	JH683	116760150805	BP260
116000120500	JJ452	6020163120	BN720	6060160120	BY580	6160160920	BC790	116760150806	BK580
116000150800	BC370	6020163520	BW380	6060160221	JM5157	6160161220	BC790	116760160100	JC928
116000150801	BC370	6020163920	BW380	6060160320	BY580	6160161420	BC790	116760179903	JF123
116000150803	BC370	6020500058	HR758	6060500058	HR5062	6160161520	BC790	116767901000	GK570

OE reference	▲ Payen	OE reference	▲ Payen	OE reference	▲ Payen	OE reference	▲ Payen	OE reference	▲ Payen
11677901300	DK570	7700267279	AG5270	7700668130	JC386	7700744797	NB866	7700858806	LT839
116850160100	JD018	7700274003	JN789	7700670732	JR635	7700744798	JD414	7700858850	JP006
77013348717	JB997	7700316230	JN248	7700670738	JR635	7700745109	JN995	7700858879	BX580
117017901300	CN306	7700423572	JE5063	7700671430	JC386	7700745716	BL960	7700859059	AC5080
7058058000	HC346	7700465265	DH683	7700671577	BG900	7700745717	BL980	7700859200	BX600
17105634000	JC414	7700468385	EY070	7700671626	BH950	7700745722	BS010	7700859266	NF860
117137901300	CN306	7700471213	JN997	7700671834	NF648	7700745723	BS030	7700859273	BX600
117177901000	GH856	7700500971	JB851	7700672860E	AD5190	7700745724	BS520	7700859307	HT025
117187901000	GC374	7700501503	JB851	7700680688	BH680	7700745725	BS540	7700859691	NF834
117187901300	DC372	7700502159	JB850	7700680689	BH690	7700746591	JC956	7700859692	NF835
7433517893	HR800	7700502706	JE648	7700681417	LT839	7700747291	NA5053	7700859751	JJ557
7438610009	DX652	7700508287	HR378	7700683866	JB851	7700748648	JC955	7700859803	BV190
7438610010	EA5620	7700508288	HR378	7700693430	HR564	7700749395	NA5053	7700859863	JD231
7545293080	JB869	7700509372	NF640	7700694142	KA625	7700850292	JN996	7700859886	JD435
7545293080A	JB869	7700510472	HR378	7700695943	JJ558	7700851083	BL910	7700860265	AD5030
7545293080B	JB869	7700512723	BF350	7700696483	BH690	7700851213	KA625	7700860266	AD5050
7553073180	JN426	7700514879	BF350	7700696484	BH680	7700851896	BX080	7700860898	JJ562
1167601704003	JD025	7700516349	JB850	7700698219	LT839	7700852506	BX570	7700862483	HR789
007603012106	KJ779	7700517057	NF634	7700702604	KA625	7700853324	HBS011	7700864070	AE5040
007603014106	KG664	7700518676	BH680	7700706149	JC669	7700853373	NF844	7700864736	BX630
007603014108	KG664	7700519829	BH680	7700711666	BG900	7700853496	JD245	7700864736F	BX630
007603016303	PA349	7700522314	NF678	7700713860	BL910	7700853753	JD416	7700865764	JD434
87660305510	NF541	7700522345	KA533	7700714702	NF752	7700853859	JN937	7700866465	JJ565
7700101348	NA5053	7700522372	JB850	7700716521	BL970	7700853879	JN994	7700866683	BY030
7700103245	NA5036	7700538234	JB850	7700716923	NA5016	7700853954	AD5040	7700866689	JD420
7700103687	JH5108	7700540568	JB851	7700718521	JN292	7700854041	JC955	7700866876	NF844
7700103938	PA5013	7700567327	BH690	7700719274	NF843	7700854252	JD463	7700866877	NF843
7700104839	HR599	7700572638	HR565	7700719666	JN555	7700854492	JC238	7700867360	JD418
7700105392	AC5070	7700575468	HR658	7700719683	NF843	7700854493	JB954	7700867870	BS530
7700105393	AC5090	7700575994	HR564	7700720788	BG170	7700854507	BG900	7700867871	BS020
7700105843	JD5910	7700580199	LT726	7700723967	JN248	7700854539	JD419	7700868132	JN997
7700105852	JD5393	7700586044	HR564	7700724333	BF350	7700854640	JN789	7700872030	BX720
7700106172	JN997	7700611182	BF350	7700732419	BL910	7700854641	JC955	7700872383	BY080
7700106783	AY720	7700613230	JN248	7700733041	BN360	7700854644	LT839	7700872534	NF856
7700106783-830198M1	AY720	7700614729	JN292	7700733464	HR300	7700854652	JB997	7700872848	HBS119
7700107181	JD5394	7700616154	BH680	7700734646	BH680	7700854710	BG170	7700872849	HBS119
7700107818	BS530	7700622018	BH680	7700735948	JJ559	7700854842	NF817	7700872850	HBS119
7700108023	AY710	7700622122	BH950	7700736277	JD411	7700854867	JD409	7700872860	AD5190
7700108023M	AY710	7700622286	JB954	7700736465	HR599	7700855230+7700855231+		7700874592	JD5189
7700108024	AY730	7700623962	NF545	7700736567	JD410	7700855034	HBS010	7700875717	AD5040
7700108024-830540PM	AY730	7700627111	NF369	7700737124	HR569	7700855382	JN697	7701020094	JN369
7700108167	AD5030	7700635407	JC386	7700738282	BX610	7700855384	HBS244	7701024762	BH090
7700108170	AD5050	7700638093	NF634	7700738987	HBS102	7700855663	JD231	7701024924	BH080
7700108254	AD5990	7700638094	NF634	7700739165	JN789	7700855717	BV190	7701026263	BE580
7700109421	JD5893	7700638592	BG170	7700739302	BX730	7700855962	JC669	7701028289	BH080
7700109906	JD5908	7700640439	BG170	7700739392	JJ407	7700856350	HBS302	7701028290	BH090
7700112365	JD5889	7700640441	JN248	7700739970	BS020	7700857117	NF859	7701029773	BM790
7700112675	AG5420	7700641718	JB997	7700740075	JC956	7700857118	NF861	7701029774	BM800
7700112739	AC5100	7700642547	BH690	7700741186	BL970	7700857119	NF858	7701030298	BL960
7700113234	BX630	7700648719	HBS116	7700741490	JD413	7700857225	JJ568	7701030299	BL980
7700113265	AC5060	7700650089	BF730	7700741501	JC955	7700858334	BY070	7701031953	JN594
7700114234	JD5886	7700650152	HR564	7700741998	BG900	7700858384	JD410	7701033527	BH080
7700114424	JH5041	7700656001	BH950	7700743161	NF634	7700858385	JD411	7701033528	BH090
7700114745	HBS372	7700658325	HR599	7700743369	BS530	7700858386	BX610	7701034967	JC054
7700115822	AC5060	7700662756	HR564	7700743903	JN732	7700858735	JD435	7701035019	NF833
7700266044	KG5012	7700665229	JN697	7700743953	JN697	7700858736	JD436	7701035217	BH080

INTERCHANGE OE → PAYEN

Vergleichsliste OE → Payen • Références croisées 1ère Monte → Payen
Intercambio entre equipo original y Payen

OE reference	▲ Payen	OE reference	▲ Payen	OE reference	▲ Payen	OE reference	▲ Payen	OE reference	▲ Payen
7701035218	BH090	7701348102	LT726	7701465162	DS580	7701472450	HM5290	7905108000	NF857
7701035740	NP067	7701348118	BH690	7701465194	DX610	7701472821	CE5210	7910003502	LV847
7701035770	JN969	7701348119	BT080	7701465195	DL961	7701473003	CD5981	7910003805	HG108
7701036311	JN936	7701348178	HR564	7701465227	DL910	7701473007	JD5885	7910003805+G21905	HG108
7701036381	BL970	7701348226	HR565	7701465261	EH680	7701473135	CE5110	7910003960	HR571
7701036382	BL960	7701348227	JB851	7701465262	DH693	7701473137	EE5110	7910006487	NF678
7701036383	BL980	7701348574	JN248	7701465265	DH683	7701473178	HBS299	7910008466	JN596
7701036387	BF350	7701348717	JB997	7701465268	DN360	7701473371	CE5200	7910008691	HG087
7701038393	AY300	7701348923	JD245	7701465270	DF871	7701473495	NA5261	7910008692	HG092
7701038871	BE580	7701349270	LT839	7701465273	EF870	7701473503	EG7950	7910009505	LT832
7701038965	BM790	7701349276	JC669	7701465274	GF356	7701473543	HBS283	7910009720	JB841
7701039145	BF730	7701349330	BH680	7701465503	DX590	7701473544	NA5118	7910009723	JN244
7701039396	BS010	7701349331	BH690	7701465765	DH080	7701473545	NA5255	7910011371	JN544
7701039397	BS030	7701349469	JR635	7701466406	DL910	7701473571	HBS373	7910018525	BM530
7701039398	BS520	7701349561	JN292	7701466407	DL961	7701474059	CG9770	7910027971	LT832
7701039399	BS540	7701349687	BH690	7701466408	EL960	7701474060	EG9770	7910028290	HG087
7701040009	AY290	7701404452	HR397	7701466416	EH694	7701474372	CC5110	7910030796	JC135
7701040010	AY300	7701418097	BH680	7701466417	DH690	7701475822	CD5980	7910033356	JE145
7701040011	AY310	7701427228	CC5060	7701466446	DX610	7701476555	HM5291	7910245291	BG130
7701040144	BX590	7701450640	DF351	7701466819	DX570	7701477450	CG9760	7910245546	JN303
7701040198	AG5270	7701451783	DF351	7701466820	DX560	7701477452	EG9760	7910245585	BG120
7701040490	AB5110	7701453783	DF351	7701467058	DX600	7701478183	CG9760	7910246393	BG120
7701040547	JJ558	7701457561	HC354	7701467144	EG176	7701716521	BL970	7910246394	BG130
7701041926	NF883	7701458309	GF356	7701467154	DV190	7703032062	PA349	7910248324	HBS127
7701042298	JJ519	7701458310	DF351	7701467230	DX610	7703053075	HBS104	7911011371	JN596
7701042340	NP067	7701458311	GF356	7701467609	DG170	7703062003	PA349	7932567498	JB842
7701043299	NP068	7701458346	GF356	7701467610	DH080	7703062062	PA349	10548015080001	BH850
7701044092	NF883	7701458347	DF351	7701467611	DX580	7703062063	PA349	11608015080401	BH850
7701044093	NF885	7701458796	DF871	7701467612	EG176	7703065212	PA858	2108100302010	BS620
7701044224	BX390	7701459392	GH683	7701467618	DX620	7703087035	NF634	18107502346	JE5012
7701044225	BX400	7701459631	GT083	7701467896	DN360	7703087071	NF541	18110634000	JA077
7701044226	BX410	7701460132	DG170	7701467918	DH683	7703087075	NF678	18111101192	JE555
7701049734	JM5131	7701460151	DG170	7701467946	DF731	7703087079	NF685	18111723843	JE555
7701049888	JM5185	7701460365	GF356	7701468142	DX720	7703087080	NF634	8200028727	AE5210
7701052719	AG9770	7701460366	GF356	7701468155	DY070	7703087097	NF722	8200030251	JE5060
7701052720	AG9780	7701460626	GH690	7701468189	DY040	7703087104	NF535	8200034315	BX630
7701052723	AG9810	7701460627	GF874	7701468385	EY070	7703087189	NF849	8200045668	JE5061
7701052724	AG9820	7701460628	DH690	7701468506	DX590	7703087190	NF850	8200049012	AG7950
7701052798	NJ283	7701461245	EF380	7701468669	DY070	7703087191	NF847	8200057611	AE5220
7701052840+7701052837+	HM5292	7701461333	DH080	7701468709	DX721	7703087192	NF846	8200060882	JM5086
7701052863	JD5896	7701461334	GH080	7701468710	DY030	7704000285	LT726	8200062273	AD5980
7701052864	JE5064	7701461765	DH080	7701469326	DG630	7704000289	KA533	8200066662	JD5393
7701059314	JM7053	7701461930	NP067	7701469762	CD5190	7704001715	JN251	8200067710	JD5911
7701061753	JD5897	7701462215	DH683	7701470176	EC5060	7708720755	BH690	8200071111	AE5200
7701108679	NA5257	7701462216	DH693	7701470288	CC5060	7812103000	HR300	8200073003	KK5643
7701203209	FY291	7701462357	EF731	7701470855	CG9740	7812103200	HR300	8200117388	JM7054
7701203212	DS381	7701462358	DF731	7701470856	CG9720	7812103800	HR300	8200121998	AE5210
7701203741	ET750	7701462492	DH696	7701470977	EG9710	7835018000	NF334	8200128551	JD5402
7701204563	DE588	7701462816	DL961	7701471360	ED5991	7837018000	NF334	8200149425	JE5062
7701204926	DE588	7701462817	EL960	7701471366	HBS310	7842706000	NB775	8200188390	AD5030
7701204945	JD421	7701463110	DL910	7701471373	HBS301	7900652756	HR564	8200215051	AE5210
7701205193	ET750	7701463203	EH680	7701471376	NA5215	7902010848	GH890	8200264952	AE5110
7701348002	BH680	7701463925	DN360	7701471777	CG5420	7903062003	PA349	8200310867	JD5884
7701348031	BF350	7701463932	DL911	7701471779	HBS431	7903065016	PA858	8200313217	JD5892
7701348088	BF350	7701464133	EG176	7701471886	CC5100	7903065023	LC292	8200351353	AG9490
7701348097	BH680	7701464134	DG170	7701472449	JD5891	7903087086	NF812	8200363223	JD5895

OE reference	▲ Payen	OE reference	▲ Payen	OE reference	▲ Payen	OE reference	▲ Payen	OE reference	▲ Payen
8200365915	JD5894	8941462490	JC684	8942480270	BK500	8944625590	JN661	9031132018	NJ349
8200379654	JH5109	8941524510	JJ454	8942485010	GM491	8944686540	NJ449	9031132106	NJ268
8200399103	AG9760	8941524521	JJ454	8942485011	GM491	8944713990	BR920	9031135003	NJ353
8200403823	JD5890	8941524522	JJ454	8942485012	GM491	8944713991	BR920	9031135008	NJ353
8200406740	AE5210	8941527890	BR200	8942485020	DM491	89448216191	NK092	9031135013	NJ353
8200428141	AE5220	8941560780	BR200	8942485021	DM491	8944821570	NJ449	9031135017	NJ353
8200459643	JD5912	8941592610	JC336	8942485022	DM491	8944830880	GR920	9031135018	NK214
8200490282	JD5888	8941653240	BM330	8942488270	DM491	8970193610	AG5080	9031135019	NK215
8200490285	JD5887	8941723410	JN776	8942488280	GM491	8970193611	AB5781	9031135049	NJ353
8200515111	AG9320	8941723411	JN776	8942488281	GM491	8970491450	NK251	9031138002	NJ102
18212671003	JE625	8941723412	JN776	8942488282	GM491	8970661960	AG7720	9031138013	NJ102
18301711968	JE5019	8941742790	BR940	8942488283	GM491	8970661970	AG7730	9031138017	NJ347
18301716888	JF191	8942007150	JN191	8942488290	GM372	8970747281	JJ555	9031138018	NJ347
18301728208	JE5019	8942007151	JN191	8942488291	GM372	8971092160	JD470	9031138022	NJ719
18301728410	JE5019	8942072840	HA313	8942488292	GM372	8971362592	AB5780	9031138024	NJ102
18307540797	JD5428	8942104020	JC060	8942488293	GM372	8971362593	AB5781	9031138025	NJ706
18307540798	JE5050	8942118650	BD360	8942488300	DR200	8971421100	AY900	9031138036	NJ347
2108329004706	GS630	8942138091	BM490	8942509700	JN613	8971421110	AY910	9031138046	NJ347
8383183160	NB775	8942149120	NJ323	8942509701	JN613	8971421120	AY920	9031138059	NA5089
18407527796	JE5048	8942149130	NJ322	8942511710	NJ449	8971485203	AB5780	9031138111	NJ102
18407530606	JD5909	8942149850	JN634	8942547880	GD363	8971723940	JM5078	9031138138	NJ102
0928905013000	HR5075	8942152200	NJ454	8942547881	GD363	119000117600	NF637	9031140006	NK050
8940281870	JN408	8942161070	NJ679	8942553450	GD363	119000150701	JN807	9031140013	NK050
8940326720	JJ376	8942168690	BD360	8942553451	GD363	119000150901	JN808	9031140108	NJ011
8940326730	JJ376	8942196400	GD363	8942554551	DM491	119000158402	LA246	9031142003	NJ344
8941017670	JN661	8942196430	DD363	8942568300	DM370	119000342201	NA5163	9031142007	NJ344
8941017671	JN661	8942210220	JC429	8942581970	BN610	119001727703	NB792	9031142008	NJ344
8941059730	NJ449	8942210250	JC284	8943125870	GR940	9002921007	NJ654	9031142012	NJ344
8941059731	NJ449	8942243130	BP980	8943125880	DR940	9002921020	NJ654	9031142014	NJ344
8941060600	NK092	8942243131	BP980	8943138030	JN777	9004310029	NJ454	9031142015	NJ344
8941060683	JD304	8942265641	JJ204	8943173711	DR991	9004311001	NJ274	9031142026	NJ344
8941075680	NJ646	8942320520	JC670	8943173721	DR991	9004311075	NJ276	9031142027	NK180
8941095531	BR990	8942324681	BK500	8943193700	GR990	9004311076	NJ098	9031145002	NJ243
8941095532	BR990	8942350600	BK500	8943193760	DR990	9004311092	NJ274	9031145003	NJ351
8941105590	PA658	8942350601	BK500	8943240530	BP920	9004311095	NJ269	9031145006	NJ243
8941116490	JC670	8942352800	BM330	8943270631	NK103	9004311109	NJ268	9031145008	NJ993
8941117500	NJ943	8942352880	JJ358	8943323270	BR990	9004311112	NJ276	9031145011	NJ243
8941140630	JJ204	8942353690	NJ322	8943358371	GP921	9004311141	NJ454	9031145026	NJ243
8941140690	JJ204	8942354760	GD363	8943358372	GP921	9004311144	NJ324	9031145047	NJ243
8941152430	DM370	8942363450	JE751	8943399970	NJ323	9004311149	NJ270	9031145069	NJ243
8941152431	DM370	8942363451	JE751	8943626640	JD303	9004311207	NK138	9031145094	NJ243
8941152432	DM370	8942391400	JN456	8943626652	JD304	9004311222	NJ269	9031148002	NJ042
8941152440	DM491	8942391401	JN456	8943627422	BW180	9004311230	NJ360	9031148004	NJ042
8941152441	DM491	8942391402	JN456	8943864410	AY840	9004311231	NK209	9031148014	NJ200
8941152442	DM491	8942392580	JJ345	8943864420	AY850	9004812006	PA387	9031148122	NJ066
8941152453	GM491	8942392581	JJ345	8944097260	JC683	9004812009	PA889	9031150002	NJ239
8941239930	BN190	8942415160	GM370	8944097261	JC683	9004812010	PA971	9031150006	NJ239
8941241730	NJ875	8942415161	GM370	8944097262	JC683	9004812011	PA952	9031150007	NJ239
8941246250	GP980	8942415162	GM370	8944127471	JD303	9007272206	KJ469	9031150049	NJ239
8941248800	BR190	8942415163	GM370	8944143000	DN610	9010509002	HBS197	9031152003	NJ645
8941298840	NJ446	8942415164	GM370	8944337320	BR990	9020111034	HBS441	9031170001	NJ001
8941451480	JC643	8942415180	DM370	8944337440	JN707	119020170400	JD223	9031170003	NJ001
8941458390	BK040	8942415181	DM370	8944383150	GR190	9030106096	KH066	9031170004	NJ001
8941462440	BP920	8942461090	JC683	8944383180	DR190	9031035001	NJ437	9031170075	NJ001
8941462441	BP920	8942461091	JC683	8944475700	JN408	9031126001	NJ703	9031170105	NJ001
8941462442	BP920	8942479031	JN707	8944610930	BM490	9031132001	NJ349	9031170120	NJ001

INTERCHANGE OE → PAYEN

Vergleichsliste OE → Payen • Références croisées 1ère Monte → Payen
Intercambio entre equipo original y Payen

OE reference	▲ Payen	OE reference	▲ Payen	OE reference	▲ Payen	OE reference	▲ Payen	OE reference	▲ Payen
9031175004	NJ407	9091302016	KJ127	9141460630	JC643	9618182380	BS730	9753127800	HR599
9031175113	NJ044	9091302017	KJ464	9150388580	BH950	9618603280	BG540	9753127880	HR646
9031176001	NA5090	9091302018	KJ466	9150683080	HG104	9618603680	BG450	9753197480	BN580
9031180001	NJ030	9091302019	KJ466	9150683180	HG092	9619100480	BY310	9753197580	BN570
9031180002	NJ030	9091302022	KJ127	9150683280	HG093	9619659980	BY310	9753198880	HR646
9031180003	NJ360	9091302022A	KJ127	9150683380	HG087	9621469980	JC759	9790015700	DF106
9031180004	NJ030	9091302023	KJ466	9152052180	BM530	9621917180	BX930	9790018200	DM530
9031180005	NJ360	9091302024	KJ466	9153738980	BF570	9621917280	BX940	9790018300	DM530
9031180068	NJ030	9091302030	PA021	9153861180	BL650	9621917380	BX950	9958548659	NJ384
9031180139	NJ030	9091302031	PA021	9153974080	BL650	9621917480	BX960	A72SX6013AA	HC285
9031185001	NF857	9091302032	PA021	119207901000	GK571	9623068080	BX880	A72SX6013BA	HC060
9031185003	NJ354	9091302033	PA021	9221160210	JE019	9623068180	BX890	A72SX6014BA	CH851
9031185004	NJ354	9091302038	HR342	9301024280	JJ283	9623068280	BX900	A72SX6014CA	CH851
9031185006	NJ215	9091302040	KJ466	9301040280	JC423	9623068380	BX910	A72SX6014DA	CH861
9031188001	NK055	9091302042	PA139	99310411101	HR805	9623068480	BX920	A72SX6014GA	CH851
9031188003	NK055	9091302044	PA192	9350144480	JN544	9624116780	HBS089	A72SX6014HA	CH851
9031190002	NJ346	9091302048	PA139	9350157280	NF369	9624851880	AA5830	A72SX6014JA	CH861
9031190003	NJ346	9091302050	PA310	9350228980	NF781	9624851980	AA5840	A73SX6014CA	CH851
9031190008	NJ346	9091302051	PA260	9400127459	NA5192	9624852080	AA5850	A76SX6013A1A	HC355
9031192001	NK015	9091302053	PA136	9400197139	GM533	9624852180	AA5860	A76SX6013AA	HC355
9031192003	NK015	9091302054	KJ127	9400197149	DM530	9624852280	AA5870	A76SX6014AA	DC240
9031192004	NK015	9091302056	KJ466	9400197169	DM533	9628139180	BX980	A77SX6008AA	GF583
9031195001	NJ240	9091302057	KJ466	9400197369	GJ720	9630117480	AH5040	A77SX6013AA	HC347
9031195002	NJ240	9091302058	KJ466	9400197379	JJ220	9630117580	AH5060	A77SX6014AA	DF580
9031195003	NJ240	9091302060	PA138	9400197849	DM533	9630142380	JM5087	A78SX6013AA	HC418
9031195005	NJ240	9091302062	PA425	9400209239	BM530	9631366780	AD5490	A78SX6014CA	DC240
9031195008	NK216	9091302064	PA138	9400807289	NA5035	9631366980	AD5500	A78SX6014DA	DC240
9031195091	NJ240	9091302065	PA385	9400956480	HR5081	9631367180	AD5510	A80SX6008CA	DJ440
9031199005	NJ566	9091302067	PA567	9400956489	HR5046	9631367380	AD5520	A80SX6013AA	HC440
9031199065	NJ055	9091302071	PA567	9456001443	BR490	9631424480	JD5881	A80SX6014BA	DJ440
9060530358	HR660	9091302072	PA136	9456002680	BR510	9635967180	AC5011	A80SX6014CA	DJ440
9060530458	HR660	9091302081	PB340	9456033280	BM530	9635967280	AC5020	A81SX6014AA	DL081
9091002075 (16x)	HBS397	9091302086	PB341	9456033480	BR490	9635967380	AC5031	A82SX6008AA	GG050
9091002077	HBS394	9091302091	PB344	9456043880	JC423	9635967480	AC5040	A82SX6008BA	GH890
9091002080	HBS315	9091302095	PB281	9456062380	BN580	9635967580	AC5051	A82SX6013AA	HC346
9091002081	HBS315	9091302101	PA5020	9463377480	JM5139	9636017380	AD5300	A82SX6014AA	DG050
9091002088 (10x)	HBS445	9091302111	PA5019	9463377580	JM5283	9636179280	AH5070	A82SX6014BA	DH890
9091002097	HBS042	9091303018	PA310	9463380380	JM5141	9636179680	AH5050	A82SX6014DA	DL401
9091002099	HBS042	9091706001	JE012	9559180480	JC415	9636180080	AH5050	A82SX6014EA	DJ441
9091002100	HBS306	9091706003	JE023	9566937980	DS820	9637271180	AA5880	A83SX6014AA	DC240
9091002101	HBS306	9091706004	JE015	9567221180	JE015	9641780680	AH5080	A83SX6014CA	DC240
9091002112	HBS209	9091706006	JE013	9567223980	EL890	9642252180	AH5090	A83SX6014DA	DM940
9091002120	HBS203	9091706008	JE048	9567224080	JC991	9642252280	AH5100	A84SX6008HA	EH850
9091002121	HBS203	9091706012	JE619	9567526480	DV190	9642252380	AH5110	A84SX6014BA	CH854
9091002136	HBS314	9091706020	JE106	9582001100	JN936	9643596780	AD5150	A84SX6014CA	CH864
9091002137	HBS312	9091706023	JE094	9600897480	BR510	9643597080	AD5130	A84SX6014DA	DN140
9091002139	HBS314	9091706026	JE124	9601004880	JC759	9643597180	AD5140	A84SX6014EA	DN470
9091002141	HBS441	9091706038	JE012	9602697680	BR780	9643597380	AD5160	A84SX6014FA	DN150
9091002152	HBS385	9091706039	JF087	9602697780	BR790	9643597480	AD5170	A84SX6014GA	CH864
9091002152 (10x)	HBS385	9091706047	JF058	9605348380	NF867	9645863080	NA5191	A85OX6013AA	HC452
9091010132	HBS200	9099242960	NJ014	9608064880	JPD45	9645863280	NA5192	A85OX6013A2A	HC452
9091302002	KJ464	9099244480	NJ014	9610505780	JC759	9651513280	AH5040	A85OX6013AA	EH752
9091302004	PA209	9099244490	NJ060	9613674580	HBS115	9652803180	AD5700	A85OX6014AA	DF351
9091302015	KH202	9099245070	NJ231	9613674680	HBS088	9750664780	HR805	A85OX6014AAA	DD955
9091302015A	KH202	9111415320	AX180	9614972480	BM530	9751080000	NF857	A85OX6014AEA	DD010
9091302015B	KH202	9113671390	JH016	9616067680	BV140	9751080080	NF857	A85OX6014AJA	DC929

OE reference	▲ Payen	OE reference	▲ Payen	OE reference	▲ Payen	OE reference	▲ Payen	OE reference	▲ Payen
A850X6014ALA	DP060	A850X6014KA	DN170	A850X6584EGA	JN344	AHU2804	NB829	AJM1148	CK525
A850X6014ASA	DF351	A850X6014KAA	CK262	A850X6584EHA	JN434	AJ0310SF0	CG7810	AJM1149	CK525
A850X6014ATA	DH681	A850X6014KLA	DC993	A850X6584EJA	JM154	AJ03102D5	JM5294	AJM1163	CK663
A850X6014AUA	DM530	A850X6014KMA	CH865	A850X6584ELA	JN533	AJ83743	AC5510	AJM1193	CK280
A850X6014BKA	DL570	A850X6014KNA	DC240	A850X6584ENA	JN562	AJ0310235	JM5293	AJM1195	CK262
A850X6014BLA	DH860	A850X6014KTA	DL402	A850X6584ERA	JN576	AJ0310271	AG7810	AJM1209	CK260
A850X6014BMA	DD630	A850X6014MA	CJ051	A850X6584ETA	JM261	AJ0310272	AG7820	AJM1211	CK665
A850X6014CBA	DM710	A850X6014SA	DD070	A850X6584FA	JM005	AJH5030	AD950	AJM1212	CK262
A850X6014CCA	DP070	A850X6014TA	CX660	A850X6584FBA	JM053	AJH5173	CD950	AJM1223	CX650
A850X6014CEA	CK663	A850X6014UA	DD950	A850X6584FCA	JN396	AJM102	CF070	AJM1231	CK263
A850X6014CGA	CJ051	A850X6051AA	BN080	A850X6584FDA	JM019	AJM104	CD950	AJM1235	CG913
A850X6014CKA	DP190	A850X6051AAA	BL030	A850X6584FFA	JN410	AJM126	CF470	AJM1238	CF474
A850X6014CLA	DL571	A850X6051BA	BN090	A850X6584FGA	HL474	AJM198	CG902	AJM1249	CG914
A850X6014CNA	DC790	A850X6051CA	BN100	A850X6584GA	JM044	AJM201	EF070	AJM1250	CF073
A850X6014CRA	DC800	A850X6051RA	BG820	A850X6584HA	JM077	AJM206	EF462	AJM1251	CF073
A850X6014CTA	DG871	A850X6051SA	BG830	A850X6584MA	JM023	AJM214	EE350	AJM1252	CG913
A850X6014CUA	DD501	A850X6051TA	BL010	A850X6584NA	JM023	AJM225	EF460	AJM3304	BB610
A850X6014DEA	DN170	A850X6051UA	BL020	A010140L2F	GW620	AJM239	EF074	AJM3321	BC630
A850X6014DKA	DD621	A850X6584AAA	JN596	A010182A2E	GS051	AJM258	EG571	AJM4459	JN512
A850X6014DMA	DD950	A850X6584AEA	JN283	A010182A2EHS	DS051	AJM273	EG411	AJM4460	JN581
A850X6014DNA	DH870	A850X6584AFA	JN297	A104215B8F	DL761	AJM276	EF464	AJM4495	JN583
A850X6014DSA	DC92B	A850X6584AGA	JM085	A104224E8G	DH060	AJM278	EB610	AJM4498	JN549
A850X6014DTA	DC935	A850X6584AJA	JN251	A2033300060	NA5248	AJM279	EG091	AJM4501	JN562
A850X6014DUA	DP011	A850X6584AKA	JM333	AAA981	NA294	AJM287	EH700	AM1323A	JN232
A850X6014EDA	DD955	A850X6584ALA	JM315	AAU8412	NB684	AJM293	EF07C	AM1412D	JB864
A850X6014EFA	DP110	A850X6584AMA	JN244	ACA4000	NA301	AJM302	AF070	AM1412E	JB830
A850X6014EGA	DJ420	A850X6584ANA	JN248	ACC5137	JE329	AJM373	AK260	AM22495B	LT639
A850X6014EHA	DJ430	A850X6584BAA	JN238	ADU1278	NB083	AJM374	AK520	AM0110235	JN427
A850X6014ELA	DD631	A850X6584BCA	JM663	ADU4086	NB684	AJM377	AK660	AM2110271	BJ890
A850X6014ETA	CJ127	A850X6584BDA	JM986	ADU4905	HR619	AJM387	AK280	AMK5028	JE289
A850X6014FBA	DN010	A850X6584BFA	JN232	ADU5738	NB684	AJM401	JM302	AYA3061	NB684
A850X6014FCA	DN041	A850X6584BGA	JM848	ADU8891	NB774	AJM402	JM315	AYA4021	NA448
A850X6014FFA	DK020	A850X6584BMA	JM669	ADU9143	NB772	AJM404	JM478	AYH2396	JE241
A850X6014FGA	DK020	A850X6584BNA	JN273	ADU9144	NB773	AJM413	JM477	B3C710602A	NK158
A850X6014FMA	DH693	A850X6584BRA	JM302	ADU9145	NB775	AJM414	JM261	B3D210271	BV430
A850X6014FNA	DH683	A850X6584BSA	JM025	ADU9154	NB774	AJM436	JM483	B5C710271	AG7850
A850X6014FTA	DK640	A850X6584BTA	JM008	AEC176	JM252	AJM501	HCO48	B6B113460A	JC784
A850X6014FUA	DL340	A850X6584CBA	JN068	AEC827	AD890	AJM502	EF464	B6F410271A	BS940
A850X6014GDA	DK441	A850X6584CEA	JN317	AEC875	AD890	AJM504	JH396	B31R-10-271	AG9080
A850X6014HAA	DK440	A850X6584CGA	JN365	AEC1332	JM252	AJM515	JH370	B61L10271	BV110
A850X6014HBA	DD502	A850X6584CHA	JN292	AEC5137	JE329	AJM517	JH445	B61P10235	JN752
A850X6014HCA	DK480	A850X6584CJA	JN285	AEG226	AF460	AJM528	HCO63	B61P10235A	JN752
A850X6014HEA	DM530	A850X6584CKA	JN454	AEU2078L	HBS105	AJM539	JH434	B64D10271	BV110
A850X6014HFA	DL550	A850X6584CLA	JN356	AEU2083	HBS105	AJM564	JH396	B541-13-460	JD5753
A850X6014HGA	DK470	A850X6584CRA	JN299	AEU2083L	HBS105	AJM601	JA439	B630-10-135 (10x)	HBS406
A850X6014HHA	DL010	A850X6584CSA	JN300	AEU2085L	HBS105	AJM602	JA282	B630-10-135(10x)	HBS406
A850X6014HJA	DM381	A850X6584DDA	JN459	AHH6358	JE241	AJM639	JA323	B30110271	BR960
A850X6014HKA	DK610	A850X6584DFA	JN496	AHT188	AF470	AJM648	JA502	B30113460	JD109
A850X6014HLA	DK611	A850X6584DJA	JM413	AHU1081	NB684	AJM681	JB765	B30210271	BR960
A850X6014HRA	DM840	A850X6584DKA	JN410	AHU1448	NB684	AJM682	JA510	B30210271A	BR960
A850X6014JCA	DJ852	A850X6584DLA	JN433	AHU2157	NB772	AJM689	JA626	B36610235	JN774
A850X6014JHA	DG811	A850X6584EA	JN279	AHU2198	NB774	AJM690	JA625	B36610235A	JN774
A850X6014JMA	CF070	A850X6584EAA	JN513	AHU2242	NB772	AJM692	JB792	B36610271	BV430
A850X6014JNA	CF073	A850X6584EBA	JN494	AHU2243	NB775	AJM693	JB894	B37610271	BR960
A850X6014JRA	CF473	A850X6584EEA	JN462	AHU2283	NB775	AJM1140	CF473	B54113460	JD5753
A850X6014JSA	CF474	A850X6584EFA	JN453	AHU2310	BP880	AJM1142	CK261	B61610271A	BP600

INTERCHANGE OE → PAYEN

Vergleichsliste OE → Payen • Références croisées 1ère Monte → Payen
Intercambio entre equipo original y Payen

OE reference	▲ Payen	OE reference	▲ Payen	OE reference	▲ Payen	OE reference	▲ Payen	OE reference	▲ Payen
B61613460A	JC974	BNP4653	NJ254	CRC0288	NA448	E5B613510A	JC630	E58099100A	GJ430
B63010155	PA883	BNP4701	DC635	CSEH951	EH952	E5D710271	BP540	E58099100B	GJ430
B63010235	JN628	BNP4711	DC636	D0RY1190A	NA580	E7EE6051C7B	BJ440	E58099100C	GJ430
B63010237A	PA858	BNP9144	JH171	D1FZ6079B	CH861	E7EE6584C8B	JN815	E58099100D	GJ430
B63010271	BP600	BNP9145	JH171	D1FZ6584C	JM478	E7EE9439A6C	J0028	E58099101	DJ430
B63010271A	BP600	BP6D10271	BS953	D1FZ6700B	NA576	E7EE9439A8C	J0028	EAC1341	NA422
B63010431A	JJ354	BP0510235	JN775	D1FZ8255A	KT738	E7GZ6051A	BP600	EAC1954	BE880
B63010602	NJ448	BP0510235A	JN775	D1FZ9448A	JA768	E7GZ6051B	BP600	EAC1955	BE890
B63011312	NJ650	BP0510271	BS950	D1FZ9448B	JA770	E7GZ6584A	JN628	EAC2912	JN539
B63013111	JC666	BP0511312	NK157	D2FZ6584A	JM510	E8BZ6051A	BR960	EAC2957	BJ020
B63013111A	JC666	BP2610271	BS950	D2RY6051A	BL090	E8BZ6051B	BR960	EAC3713	BJ020
B63013135	JC665	BTA695	NA448	D2RY6051B	BL080	E8EE6710A8A	JJ455	EAC4219	NA422
B63013460	JC664	BTA9014	NA448	D2RY6701A	NB564	E9RE6051A7A	BX480	EAC4419	JN180
B63013460A	JC664	BTA9015	NA301	D3FZ6781AA	HC418	E17Z6079A	CJ127	EAC4691	JC241
B66010155	PA956	BTC357	NA380	D4Z26584A	JM875	E17Z6571A	KJ710	EAC5032	HR299
B66010271	BP570	BWC0322770	DN233	D2Z21190A	NJ042	E43E6700D	NJ324	EAC5039	JN180
B66010271A	BP570	CODE9453A	JE289	D2Z26051A	AJ230	E43Z6584B	JN576	EAC7504	BT070
B66010271B	BP570	C3NE6701A	NB564	D2Z26584A	JM019	E43Z9448A	JC477	EAC7954	NB720
B66010271C	BP570	C5NNP709B	NA294	D2Z26700A	NJ042	E92Z6584A	JN692	EAC8815	NA422
B66013460	JC781	C2318	JA272	D2Z26701A	NJ040	E23497	NF694	EAC8994	HA5010
B69513460	JC781	C3002	NB584	D2Z26710	JH015	E834078S	KT738	EAC9638	BE880
BAU5092	BK580	C6735	JM448	D2Z26710A	JH015	E853100S	KT738	EAC9639	BE890
BAU5093	BP260	C8593	NA422	D2Z29448A	JB802	E10110271	BJ420	EBC1551	BT070
BAU5094	BK570	C8981	JE231	D4Z79450A	JE674	E10199101	DJ420	EBC3956	HR5050
BDU1772	JJ315	C11934	NB684	D5Z26584A	JM019	E30110235	HL508	EBC9527	JM536
BDU2140	JJ315	C12664	CE542	D5Z29448B	JC251	E30110235A	HL508	EBC11081	JC241
BDU2388	BP880	C12665	CG571	D9Z26008B	FJ127	E30110235B	HL508	EBC11330	HA5011
BHM1391	DK450	C12729	EG571	D9Z26051A	AJ120	E30110271	BJ430	ECP7248	BM990
BHM1392	EF464	C14988	JM447	D9Z26079B	CJ127	E30110271A	BJ430	ERC3605	JB792
BHM1393	DK451	C19113	AE540	D9Z26571A	KJ468	E30110271B	BJ430	ERC3606	JB792
BHM1393B	DK451	C28974	BJ020	D9Z26571B	KJ710	E30110431	JJ149	ERC3990	JB894
BHM1394	EF464	C29428	JM536	D176 404.A2	HR397	E30113510	JC250	ERC5122	BN600
BHM1424	EK451	C29429	JM537	D691M6014BA	DJ202	E30113510A	JC250	ERC6380	BN600
BHM1429	EF07C	C31636	BJ020	D711M6014CA	DJ202	E30123099	JJ149	ERC7865	HR5052
BHM1484	EK451	C36126	BJ020	D176404.A2	HR397	E30140305	JE102	ERR382	BY470
BHM1586	DN671	C39199	JN180	D4Z26584A	JM875	E30199100	GJ430	ERR383	BY480
BHM1587	DN671	C41247	JA793	D40199101	DE545	E30199100A	GJ430	ERR384	BY490
BHM1589	EM684	C67351	JM448	D40799101	DE545	E30199100B	GJ430	ERR1208	JC886
BHM1607	DP880	C149881	JM447	D50699101	DE545	E30199101	DJ430	ERR1632	NB849
BHM1608	DP881	C184051	JE231	DA72SX6014JA	CH861	E30199101A	DJ430	ERR1636	BY470
BHM1609	EM685	C246111	NA422	DA73SX6014CA	CH851	E30199101B	DJ430	ERR1637	BY480
BHM1617	DS791	C246112	NA422	DA04112871067	DR880	E30210271	BJ430	ERR1638	BY490
BHM1619	DS791	CAM7524	BD970	DBP4100	JJ309	E30340395	JE101	ERR1782	HR5053
BHM1624	EM682	CAM7557	JC435	DBP4105	BM990	E30340395A	JE101	ERR2393	JN872
BHM1625	EM682	CAM7774	BN670	DBP4106	BM990	E30540305	JE102	ERR2409	JP020
BHM1627	DL381	CAM7777	JJ315	DBP4141	EM992	E50110271	BJ430	ERR2532	NB848
BHM1639	BD970	CAM8298	JC240	DBP9265	JN562	E50110271A	BJ430	ERR2943	HBS222
BNP2644	JH171	CAM9780	BL380	DBP9278	BM990	E50413502	JC163	ERR3355	NC009
BNP2714	PA286	CAM9991	NB772	DBP9347	JJ309	E50813111	JC183	ERR3356	NC008
BNP2716	PA288	CAM9992	JN549	DBP9737	EM992	E52340581	JE185	ERR3366	NC008
BNP3115	JC414	CBC4834	JE231	E1FZ1177A	NA585	E56313111	JC642	ERR3682	DM852
BNP3416	NJ072	CDU1890	JJ404	E1FZ6584A	JN332	E56313111A	JC642	ERR3785	JD471
BNP3417	NJ073	CDU3860	HR656	E5A113111	JC551	E58010271	BJ430	ERR4537	BY470
BNP3418	NJ254	CKP9000	EC633	E5A113111A	JC551	E58010271A	BJ430	ERR4538	BY480
BNP4627	JH171	CKP9007	DC636	E5A199100A	GJ431	E58010271B	BJ430	ERR4539	BY490
BNP4628	JH171	CKP9008	EC633	E5A199100AHS	DJ431	E58099100	GJ430	ERR4576	NC009

OE reference	▲ Payen	OE reference	▲ Payen	OE reference	▲ Payen	OE reference	▲ Payen	OE reference	▲ Payen
ERR5261	BY470	F60199100HS	DM300	GEG286	EG914	GUG701628CS	ER322	H62799100	FJ232
ERR5262	BY480	F80110235	JN533	GEG296	EK451	GUG701629CS	EZ690	H62799100A	FJ232
ERR5263	BY490	F80110235A	JN533	GEG298	EG914	GUG701630CS	EZ440	HE1099100	FJ127
ERR5437	AY200	F80110235B	JN533	GEG301	AF460	GUG702523HG	BS790	HE1099100A	FJ127
ERR5992	NA5023	F80110235C	JN533	GEG404	JM302	GUG702534HG	BS860	HE1099100B	FJ127
ERR6130	NB843	F80110235D	JN533	GEG502	HC031	GUG702568HG	BZ440	HE1099100C	FJ127
ERR6824	AB5900	F80110271	BL320	GEG692	JB792	GUG702569HG	BZ450	HE1910155	KJ710
ERR7029	JH5012	F80110271A	BL320	GEG1206	CH832	GUG702570HG	BZ460	HE2613111	JA021
ERR7094	JM5034	F80110271B	BL320	GEG1248	DE880	GUG702576HG	BW750	HG1812	JB842
ERR7154	BY500	F80110271C	BL320	GEG1257	DK570	GUG702580HG	AB5400	HG23187	KA606
ERR7217	AY200	F80110271D	BL320	GEG1269	EG914	GUG702607HG	AB5080	HG132204A	JN245
ERR7218	AB5480	F80110431	JJ268	GEG12840	CH832	GUG702608HG	AA5920	H0061A1PA1020030	DC636
ERR7306	JA5000	F80110602	NJ324	GHS5186	NB596	GUG702610HG	BZ710	H0061A1PE3000010	DM995
ETC5301	BM850	F80111399	NJ325	GUG1004	DW750	GUG702611HG	BZ690	H0061B1PE0000010	EM992
ETC6438	JM350	F80113111	JC401	GUG1004HS	DW750	GUG702612HG	BZ700	H012251634000010	BC630
ETC6439	JM356	F80113111A	JC401	GUG1006HS	DW750	GUG703004SG	JJ404	H0BNP4701	DC635
ETC7401	BM850	F80113111B	JC401	GUG1007	DW755	GUG703040SG	JH5022	IS8942488290123	GM372
ETC7750	JC882	F80113460	JC400	GUG1007HS	DW755	GUG703044SG	JH5016	IS8944383180	DR190
ETC7788	BM850	F80113460A	JC400	GUG1012HS	DW5757	GUG703058SG	JH5032	J0411235330	DM881
ETC7819	BR290	F80199101B	DL321	GUG1014HS	DW5757	GUG703059SG	JH5033	J0411273043	GP650
ETC8808	HBS224	F80199101C	DL321	GUG1059HS	DS860	GUG703060SG	JH5012	J9010512092 (10x)	HBS386
ETC8808+ETC8810+		F80210271	BL320	GUG1111HS	DS862	GUG704002MG	JD656	J9010512092(10x)	HBS386
ERR1939	HBS223	F80211399	NJ325	GUG1112HS	DS792	GUG704004MG	JC877	JAM1202	AE780
ETC8809	HBS224	FE1H10271	BR730	GUG2523HG	BS790	GUG704027MG	JC949	JE01102H0	BR970
ETC8810	HBS224	FE1H10271A	BR730	GUG2534HG	BS860	GUG704052	JD311	JE01102HOA	BR970
FORE6710AA	JJ455	FE1H10271B	BR730	GUG4052	JD311	GUG704056MG	JD657	JE0110270	BR980
F1BZ6854A	JN628	FE3N10235	JN717	GUG4403MG	JD654	GUG704064	JD563	JE0110270A	BR980
F3AE6701AA	NA5175	FE3N10235A	JN717	GUG701059HS	DS860	GUG704064MG	JD563	JF0110235	JN714
F32Z6051A	BV380	FE3N10271	BR850	GUG701060HS	DS795	GUG704066MG	JD441	JF0110235A	JN714
F32Z6584C	JN877	FE5H11399	NJ325	GUG701111HS	DS862	GUG704091MG	JA5079	JF0110602	NJ978
F43E9448A7J	JD5747	FE5H11399A	NJ325	GUG701115HS	DW755	GUG704094MG	JD311	JF0110602A	NJ978
F43E9448-A7J	JD5747	FE0110602	NJ324	GUG701125	DW5757	GUG704403MG	JD654	JF0111312	NK035
F43X6014	CC5870	FE0210602	NJ324	GUG701126HS	DZ440	GUG704412MG	JC909	JF0111312A	NK035
F20110235	JN692	FE1013460	JC400	GUG701136HS	CB5400	GUG704430MG	JC852	JF0112602	NJ985
F20110235A	JN692	FE3010271	BL320	GUG701137HS	CB5400	GUG704435MG	JA5078	JF0112602A	NJ985
F20110235B	JN692	FE3010271A	BL320	GUG701138HS	DW756	GUG704446MG	JD5183	JF0113460	JC931
F20110235C	JN692	FE3010271B	BL320	GUG701147HS	DS793	GUG704806MG	LA564	JLM113	DT070
F20110235D	JN692	FE8513460	JC400	GUG701154	DW754	GUG704809MG	JC950	JLM1720	CH831
F20113111	JC779	FE8513460A	JC400	GUG701154HS	DW754	GUG704816MG	JD564	JLM9534	DJ024
F20113460	JC777	FE8513460B	JC400	GUG701194HS	DW5757	GUG704817MG	JC907	JLM9730	DJ022
F20113460A	JC777	FP3910271	BV380	GUG701200HS	CB5080	GUG704821MG	JD655	JLM9731	DJ023
F20113460B	JC777	FS01-10-135	HBS136	GUG701201HS	DZ690	GUG705006VC	JN963	JLM11088	DT070
F20113464	JC778	FS01-13-111A	JD5754	GUG701203HS	DW5757	GUG705025VC	LB161	JLM11383	DT071
F20210271	BR730	FS01-13-460	JD331	GUG701204HS	DW5757	GUG705040VC	LB536	JLM11649	DT072
F20210271A	BR730	FS0110271	BV380	GUG701207HS	DW754	GUG705045VC	JP097	JLM12305	DT072
F22010271A	BR730	FS0111399	NK205	GUG701208HS	DW756	GUG705047	JN963	JLM12440	CC5261
F60110271	BM300	FS0113111A	JD5754	GUG701209HS	DW750	GUG705053VC	JM5045	JLM20751	CC5262
F60110271A	BM300	FS0113460	JD331	GUG701210HS	DW5757	GUG705054VC	JP065	JLM20935	CC5260
F60110271B	BM300	FS0510271A	BV380	GUG701211HS	DW5757	GUG705055VC	JP007	JS61331	CH831
F60110271C	BM300	G60110271	BS280	GUG701583CS	ER320	GUG705062VC	JM5046	K0AH1-10270A	CG9870
F60110271D	BM300	G60110271A	BS280	GUG701584CS	EB5400	GUG705069VC	JM5035	K0AJ710270	FG8260
F60140395	JF017	G60110271B	BS280	GUG701585CS	ER321	GUG705073VC	JM5076	K418AF02	NB774
F60140395A	JF017	GEG242	EG914	GUG701590	ER322	GUG705074VC	JN963	K418FF01	NB772
F60199100	GM300	GEG269	EG914	GUG701590CS	ER322	GX0316801A	JB833	K418FF02	NB773
F60199100A	GM300	GEG276	EF464	GUG701591CS	EZ440	GX0410301A	JB833	K418FF05	NB775
F60199100B	GM300	GEG279	EG091	GUG701627CS	ER321	H75AB9451AC	JE719	K28850	NA298

INTERCHANGE OE → PAYEN

Vergleichsliste OE → Payen • Références croisées 1ère Monte → Payen
Intercambio entre equipo original y Payen

OE reference	▲ Payen	OE reference	▲ Payen	OE reference	▲ Payen	OE reference	▲ Payen	OE reference	▲ Payen
K4111400	NJ007	LUF100530L	NA5103	MB548649	JF095	MD020308	NJ057	MD076481	JC441
K4111403	NJ007	LUF100540	NA5104	MD000248	NJ008	MD020435	NJ251	MD081533	JC224
KF0110271A	BX780	LUF100540L	NA5104	MD000254	NJ007	MD020747	HL509	MD081993	JC626
KF0110272A	BX790	LUJ10002	JN736	MD000262	JH034	MD024512	HL509	MD084230	JC632
KJ01102D5	HMS269	LVB000100L	BZ710	MD000267	JH034	MD024529	NJ334	MD085548	BN220
KJ0110235	HMS270	LVB000190	AB5900	MD000433	AJ690	MD024682	JN427	MD088384	KJ577
KJ0110271	AG8150	LVB000210	AB5920	MD000437	BD010	MD025593	JC125	MD088445	JC122
KJ0110272	AG8160	LVB000230	BW750	MD000443	FJ690	MD026652	HL509	MD088581	BJ600
KL31-13-111	JD5756	LVB000240	AB5900	MD000508	KJ211	MD026654	BJ890	MD088855	NJ874
KL68-13-460	JD5755	LVB000250	AB5910	MD000519	JM023	MD027939	GJ891	MD093227	JC611
KL01102D5A	JN833	LVB000260	AB5920	MD001379	JC272	MD027939HS	DJ891	MD095355	NJ655
KL0110155	PB313	LVB10001	BN670	MD001430	AX190	MD030133	JJ098	MD096264	NJ655
KL0110235A	JN832	LVB10003	BN670	MD002268	JH034	MD030282	JN317	MD099568	BN220
KL0110271B	BV410	LVB10010	BW750	MD002520	JM023	MD030293	BE070	MD101666	JC719
KL0110272B	BV420	LVB10045	BS790	MD002522	JM023	MD030468	JC023	MD101915	NJ873
KL0210155	PB314	LVB10048	BS790	MD004430	AJ690	MD030680	JC122	MD104623	JC751
KL3113111	JD5756	LVB100760	BW750	MD004432	AJ690	MD030681	JC123	MD108180	JC611
KL6813460	JD5755	LVB100910	BZ440	MD004433	AJ690	MD030789	NJ252	MD110383	BJ890
KN1629A	GF492	LVB100920	BZ450	MD005900	FJ690	MD031630	JC122	MD111805	BR600
L681EF06	BP880	LVB100930	BZ460	MD005900NK	CJ690	MD031631	JC123	MD112095	JC968
L681KF06	JJ315	LVB101000	AB5400	MD005909	FJ690	MD031837	NJ252	MD112531	BS130
LDN10027	HBS423	LVB101380	AB5080	MD006268	KJ577	MD034093	BD980	MD113173	BS120
LDN10027L	HBS423	LVB101630	AA5920	MD007015	BD040	MD034094	BK410	MD113178	BS240
LGP100310L	HR5045	LVB101820L	BZ690	MD007383	JN365	MD034095	BD040	MD113195	JC793
LJQ100560B	HR656	LVB101830L	BZ700	MD007515	BD040	MD034235	JC124	MD115000	JC751
LJQ100940	HR5044	LVB101840L	BZ710	MD008762	NJ242	MD040342	JJ274	MD115472	PA968
LKG10002	JC909	LVB500190	BW5750	MD008766	BD040	MD040514	HBS295	MD117643	NJ006
LKG10011	JC852	LVB1000760	BW750	MD008769	HBS440	MD040532	BL450	MD117728	JC795
LKG100290L	JA5078	LVC100260	JM5000	MD008828	JC124	MD040533	BH060	MD117729	JC795
LKG100470	JA5076	LVF10005	JJ446	MD008882	NJ005	MD040974	JC493	MD120091	JN713
LKG100590L	JD5183	LVF100290	JH5016	MD008885	NJ006	MD041012	NJ610	MD124763	JC794
LKJ000010	JA5075	LVF100380	JH5014	MD008897	JJ075	MD041329	JC612	MD125939	JN715
LKJ10027	JC949	LVF100420L	JH5032	MD009038	NJ255	MD041512	JN496	MD130494	JN788
LKJ10029	JC877	LVF100430L	JH5033	MD009366	KJ577	MD050092	GJ600	MD133317	NJ933
LKJ10030	JC950	LVP000020	JM5074	MD009447	GD040	MD050092HS	DJ600	MD133671	JN713
LKJ100680	JD441	LVP10006	LB162	MD009448	GD040	MD050109	KJ211	MD137976	BS130
LKJ100992L	JA5079	LVP100260	JN963	MD009451	BD040	MD050312	JN403	MD138312	BR600
LKJ101120	HA5006	LVP100470L	JM5035	MD009515	BD980	MD050482	JC224	MD143540	BR600
LQX10002	NB828	LVP100620L	JM5076	MD009519	BD980	MD050545	BJ600	MD143995	JN897
LQX100040	NB828	LVP100630	JN963	MD009974	GD042	MD050604	NJ251	MD145826	BV010
LQX100070	NA5083	LVQ000090	DW5757	MD010313	BK410	MD050605	NJ255	MD147241	BR600
LUB10009	HR802	LVQ10001	DL382	MD010430	AX190	MD050606	NJ005	MD150161	NK143
LUB10026	HR752	LVQ10009	DS793	MD010431	AX190	MD050608	NJ610	MD150525	JD023
LUB100350	HR752	LVQ10010	DW750	MD010446	AX190	MD062144	BM830	MD151227	BK410
LUC100220	NB998	LVQ10012	ER320	MD012189	JC611	MD065959	HBS402	MD151232	BT430
LUC100290	NC065	LVQ10014	DN676	MD012886	BK410	MD065959 (16x)	HBS402	MD153103	NJ242
LUC100290L	NB586	LVQ10040	DS795	MD012887	BK420	MD066163	BN330	MD153104	NJ252
LUF10001	NB829	LVQ10041	DS860	MD012908	JN599	MD066813	BN220	MD154781	BJ600
LUF10002	NB772	LVQ10042	ES790	MD015051	JC272	MD068905	JC612	MD157084	JD007
LUF10007	NB843	LVQ101240	EZ690	MD015521	JN317	MD069947	NJ251	MD157195	JC969
LUF10008	NB828	LVQ101240L	EZ690	MD015623	JN365	MD069948	NJ255	MD160942	BS130
LUF10019	NB829	LVQ101250	DZ690	MD016163	BN230	MD069949	NJ005	MD163293	BN220
LUF100300	LK5000	LVQ101250L	DZ690	MD016310	NJ242	MD069950	NJ610	MD163597	BT430
LUF100420	LK5002	MA152415	JE011	MD016490	KJ570	MD070669	JC554	MD164738	HBS215
LUF100430	LK5009	MB009242	JE052	MD016549	NJ006	MD072804	JC023	MD165614	BR600
LUF100530	NA5103	MB431544	JE199	MD020232	JJ072	MD075976	JC272	MD166371	JD5757

OE reference	▲ Payen	OE reference	▲ Payen	OE reference	▲ Payen	OE reference	▲ Payen	OE reference	▲ Payen
MD166720	BV010	MD971345	CF5500	MD997116	GN220	ME202850	NA5243	NoInfo+E6559	CB5001
MD167815	JN800	MD971622	CG9120	MD997134	DN221	ME202851	NA5244	NR400000321	NB633
MD168005	NJ874	MD971623	CG5400	MD997135	GN221	ME203250	NA5244	OK2CA 10 270	EG9190
MD168061	NJ005	MD971653	CG5520	MD997136	DK412	ME203686	JM5292	OK2CA10270	EG9190
MD172796	JD5758	MD972932	CA5390	MD997145	DT880	ME204037A	AG7740	OK24710235B	JM7038
MD173023	BT880	MD972933	FA5390	MD997146	GT880	ME204038B	AG7750	OK24710271G	AG9190
MD173371	JM7039	MD974193	FG7680	MD997160	GH061	ME204039	AF5490	PN1110235	JN710
MD174560	HM5245	MD974547	CF5470	MD997163	GH062	ME204040D	AG7760	PN1110235A	JN710
MD174796	BS130	MD974548	FF5470	MD997165	GH064	ME993318	FF5490	PN1110271	BS070
MD174940	NK143	MD974946	FF5470	MD997168	GT880	ME995720	FF5490	PN1110271A	BS070
MD177339	BT890	MD975562	CG9150	MD997170	GN221	ME995720HS	CF5490	PN1110271B	BS070
MD182502	JD131	MD975563	EG6230	MD997232	DJ600	ME996019H	CA5021	PN4110271	BS070
MD183808	BS120	MD976462	CG9130	MD997233	GJ600	ME999120	GM750	R2B610271	BN620
MD184399	BT890	MD976844	CG6120	MD997234	DN332	ME999120HS	DM750	R2B610271B	AG5110
MD186786	JN889	MD976845	FG6120	MD997235	DN233	ME999284	GM750	R2B6-10-271B	AG5110
MD188435	HM5239	MD976861	CG7691	MD997237	GN233	MIMD997023	DJ601	R95VW6051AA	BX810
MD189395	AG5300	MD978012	CG7690	MD997248	DS130	MIMD997052	GJ601	R20110271D	BN620
MD190393	BT880	MD978013	FG7690	MD997249	GS130	MIMD9972487433	DS130	R20110271E	BN620
MD191470	HBS354	MD978094	CE5612	MD997254	DH062	MIMD9972497434	GS130	R20110271F	AJ230
MD191474	HBS421	MD978095	FG7710	MD997255	GH062	MN163441	JD5905	R20110271G	BN620
MD192250	JC124	MD978114	CG7700	MD997311	DR600	MN163442	JD5871	R20199100	GN620
MD194264	AG5140	MD978240	CF5481	MD997312	GR600	MN195370	AG9920	R20199100A	GN620
MD194265	AG8080	MD997013	DE070	MD997433	DS130	MRFTA10271	AG5130	R20199100B	GN620
MD194294	JM5006	MD997014	DK410	MD997435	DR600	N 901 316 02	JD236	R20199100C	GN620
MD197286	AG5150	MD997015	DK420	MD997436	GR600	N 901 316.02	JD236	R20199100D	GN620
MD198014	AF5500	MD997023	DJ601	MD997455	DN233	N0138452	PA349	R20199100E	GN620
MD199174	AG5140	MD997027	GE071	MD997456	GN233	N0138492	KG664	R20199101	DN620
MD301578	AG5302	MD997029	GK410	MD997468	CC5750	N138492	KG664	R20199101A	DN620
MD301579	AG5300	MD997030	GK420	MD997469	DS241	N138512	KJ779	R20199101B	DN620
MD301580	AG5301	MD997040	GE071	MD997470	DS120	N804732S	HBS001	R20199101C	DN620
MD302090	JM5289	MD997043	GK410	MD997471	DS120	N901316.02	JD236	R20199101D	DN620
MD302900	AG7680	MD997044	GK420	MD997472	GS240	N8066838S	HBS006	R20199101E	DN620
MD303148	JM5247	MD997046	GH061	MD997473	GS241	N90131602	JD236	R20210271	BN620
MD304511	BK420	MD997051	GJ891	MD997474	GS120	N7701465261	EH682	R20210271F	AG5110
MD305835	JD5781	MD997052	GJ601	MD997475	GS120	NBC2520AB	BT070	RF1L10271C	AG5130
MD307705	HM5271	MD997060	DH061	MD997477	DM830	NBC2520BB	BT070	RF1L1071B	AG5130
MD309720	JD5759	MD997061	DL450	MD997479	GM830	NBC2525AA	JN927	RF2A10235	JM5315
MD312914	JM5022	MD997065	GJ897	MD997488	DR601	NBC2909AA	HA5011	RF2A10271A	AG8190
MD314651	AF5500	MD997066	DJ898	MD997496	GR600	NCA2540AD	AC5260	RF0110135	HBS211
MD320044	AG6120	MD997089	GK420	MD997496HS	DR600	NCA2541AD	AC5270	RF0110155	PA659
MD322820	AG7710	MD997090	GK420	MD997513	DM831	NCC2540BC	AC5260	RF0110235	JN576
MD323473	BT430	MD997093	DE070	MD997640	DV010	NCC2541BC	AC5270	RF0110235A	JN576
MD331145	AF5470	MD997094	GE072	MD997645	DT431	NI10101C68252627	GJ360	RF0110271	BN620
MD333227	AG9150	MD997095	GJ897	MD997647	GT431	NI11042C6825	DJ360	RF0112602	NJ448
MD333279	AE5610	MD997098	DH062	MD997671	DT430	NI1010105E7576	GR360	RF0113111	JC598
MD342281	HM5244	MD997099	GH062	MD997672	GT430	NI1010109W2627	GM581	RF0113462	JC477
MD342397	AF5480	MD997100	DL452	ME001061	BE410	NI1010157Y26	GP960	RF0199100	GN620
MD346750	JM5232	MD997104	DM830	ME001136	BM750	NI1010170J25	GV541	RF0199100HS	DN620
MD346924	AA5390	MD997105	GM830	ME001166	PA468	NI1010171J25	GV440	RF0310271D	BN620
MD348283	JM7041	MD997106	DH064	ME200403	HM5230	NI1104205E252728	DR360	RF0310271E	BN620
MD351292	AG7690	MD997107	GH064	ME200426+ME200848	HBS216	NI1104209W2627	DM581	RF0310271F	BN620
MD355550	HBS477	MD997108	DN330	ME200751	AA5020	NI1104257Y25	DP960	RF1099100	GM730
MD361466	AG9120	MD997109	DE070	ME200752	AG5160	NI1104270J25	DV541	RF1099100A	GM730
MD365937	AG7700	MD997112	GN330	ME200753	AA5020	NI1104271J25	DV440	RF1099100B	GM730
MD970441	DT890	MD997113	GN230	ME200754	AA5020	NNA3020BA	JD144	RF7110271D	AG5130
MD970444	GT890	MD997115	DN220	ME202145	JA5014	No OE set	CB5670	RF7110271F	AG5130

INTERCHANGE OE → PAYEN

Vergleichsliste OE → Payen • Références croisées 1ère Monte → Payen
Intercambio entre equipo original y Payen

OE reference	▲ Payen	OE reference	▲ Payen	OE reference	▲ Payen	OE reference	▲ Payen	OE reference	▲ Payen
RFJ5-10-271D	AG5130	SE0110155	PA606	TAM2121	AF070	XS4Q6051BD	AB5310	Z50510235A	JM5287
RFJ510271B	AG5130	SE0110235	JN553	TKC0117	BB610	XS4Q6051CD	AB5320	ZC9000271	DM530
RFJ510271C	AG5130	SE0110271	BL880	TKC0249	AK520	XS4Q6051DD	AB5330	ZC9412552U	NF637
RFJ510271D	AG5130	SE0110431	GV431	T00411258040	DJ742	XS4Q6051ED	AB5340	ZC9412557U	NF677
RTC0379	EH690	SE0112117	PA606	T004111540404142	GL951	XS4Q6051FD	AB5350	ZJ0110235	JM5311
RTC0380	DJ022	SE0113461	JC443	T004112540303132	DL951	XS4Q6051NA	AB5800	ZL0110235	JM5319
RTC809	ED770	SE0123099	JJ420	T004112580101112	DJ740	XS4Q6051NB	AB5800	ZL0110271A	AA5030
RTC0811	EG914	SE0199100A	GL880	UAM1093	BD970	XS4Q6051PA	AB5810	ZY0110271A	AG8170
RTC811	EG914	SE0199100B	GL880	UAM1636	NB775	XS4Q6051PB	AB5810		
RTC1760	CK260	SE0199100BHS	DL880	UAM2287	BN670	XS4Q6051RA	AB5820		
RTC1913	DJ023	SE0199100C	GL880	UAM2794	JJ315	XS4Q6051RB	AB5820		
RTC2104	EG914	SE0199104	GV431	UAM3543	NB775	XS4Q6051TA	BW020		
RTC2576	CG915	SE0199104A	GV431	UAM5445	JC908	XS4Q6051UA	BW030		
RTC2731	CG915	SE0810602	NJ367	UAM7323	JN836	XS4Q6700AD	NA5013		
RTC2889	DN600	SE0811399	NJ330	UKC3118	CX650	XS4Q6710AE	JH5008		
RTC2890	ED771	SE4599100HS	DL880	UKC3250	NB596	XS4Q6K260AB	JM5016		
RTC2913	CG914	SE020000020A	GP011	UKC4785	JB765	XS4Q6K301AE	NC086		
RTC2916	ED771	SE020000032A	DP011	UKC4785B	JB765	XS4Q6K301AF	NC086		
RTC3037	DM850	SE020004000A	HC027	V83SF9441AA	JD5746	XS6E6065AB	HBS358		
RTC3038	EM850	SE021004000A	EA3130	V85SF6051AA	BN470	XS6E6571AA	PA5033		
RTC3297	CD950	SE021006000B	CA3130	V85SF6051AB	BN470	XS6E6584AB	JM5104		
RTC3301	EG411	SE021006000C	CA3140	V97DD6051AA	AY400	XS6E6710A2B	JH5046		
RTC3306	EG914	SE021006000D	CA3130	V97DD6051BA	AY410	XS6E9441BA	JD5220		
RTC3311	AK660	SE021006121A	AA3130	V97DD6051CA	AY420	XS6G9441AA	JD5151		
RTC3324	JA282	SE021006121B	AA3140	VAM2490	BS790	XS7G 6051BC	AC5800		
RTC3331	CK663	SE021006142A	HBS044	VX021133227JVX	JD5232	XS7G6051	AE5320		
RTC3335	CD770	SE021006221A	JM2052	W81SM6571A2C	HR631	XS7G6051BB	AC5800		
RTC3336	CG210	SE039442760	HR646	W703983S430	HBS243	XS7G6051C1B	AB5260		
RTC3337	CG914	SE039442760A	HR599	W703985S430	HBS243	XS7G6584AC	JM5184		
RTC3509	NB685	SE700004221A	JJ136	WAM2293	HBS005	XS7G9461AA	JD5312		
RTC3798	CG913	SE700006121B	BG820	WAM2935	JC852	XS7Q6051AE	AA5970		
RTC3906	EM850	SE700006121C	BG830	WL0113111A	JD5131	XS7Q6065A2D	HBS296		
RTC4892	JN581	SE021006221A	JM2052	WL0113460	JD5132	XS7Q6065C2C	HBS296		
RTC4994	CG915	SGJ586	EH952	WLY110271B	AA5130	XS7Q6385AB	NA5030		
RTC5023	DP880	SL0110271	BP840	X1041AA000 HS	DN550	XS7Q6571AD	HR5082		
RTC5296	JJ315	SL0110271A	BP840	X1041AA000HS	DN550	XS7Q8565AA	HA5020		
RTC5307	NB772	SL0110442	JJ386	X1041AA001	GN551	XU3E6051AB	AC5870		
RTC5309	NB773	SL0110443	JJ386	X1041AA001HS	DN551	XU3E6083AA	AC5880		
RTC5310	NB775	SL0199100	DP840	X1041AA002	GN551	XW4E6710BC	JH5065		
RTC5312	BP880	SL0199101	DP840	X1041AA010	GN560	Y401-13-460	JD5829		
RTC5422	NB775	SSDK092	DM769	X1041AA010 HS	DN560	Y601-10235	JM7034		
RTC5428	NB773	SSDL470	DP581	X1041AA010HS	DN560	YB0225	KA289		
RTC5429	NB774	STC362	DV720	X1041AA011	GN561	YC1Q6051CE	AA5960		
RTC5465	BN670	STC363	EV720	X1041AA011HS	DN561	YS4E6051AA	BZ780		
RTC5477	NB775	STC494	DR290	X1041AA016	GN552	YS4E6051BA	BZ780		
RTC5590	EM684	STC1558	EM852	X1041AA016HS	DN552	YS4G6051CA	AC5860		
RTC5591	DN672	STC1639	EG914	X039481870	AA3140	YS6G6051A2B	AC5890		
RTC5626	JJ315	STC1640	DN600	X039481880	AA3130	YS6G6051BA	AB5120		
RTC5774	DM852	STC1641	DR290	X03962184	HR805	YS6G6051C2A	AC5890		
RTC5775	EM852	STC2031	BZ120	X039442760	HR646	YS6G6659EB	KA5021		
S1141024	CB5230	STC2801	EY470	XR85386	AC5390	YS6G9448EC	JD5219		
S20399100	FJ631	STC2802	DY470	XR85388	AC5400	Z501-10-135	HBS420		
S20399101	CJ631	STC2823	EY200	XR843470	AC5390	Z501-10-271	AG5120		
S21099101	CJ633	STC4082	CY200	XR843474	AC5400	Z505-10-235A	JM5287		
S21399100	FJ632	TAM1073	AF460	XS4G6051CA	AC5860	Z50110271	AG5120		
S26099100A	FJ632	TAM1521	AF460	XS4Q6051AD	AB5300	Z50510235	JM5287		

HOW TO USE INTERCHANGE GOETZE → PAYEN

KEY	
Product	With
Cylinder Head Gasket	+ CHG
Inlet Manifold Gasket	+ IMG
Exhaust Manifold Gasket	+ EMG
Valve Cover Gasket	+ VCG
Oil Seals	+ Oil Seals
Valve Stem Seals	+ VSS
Sump Gasket	+ SG
Quantity	Goetze(5) Payen(1)

e.g. Goetze pack quantity is 5 & Payen pack quantity is 1

e.g.

Goetze ref.	Payen ref.
21-24964-20/0	DY740 +CHG

NOTE: Only significant differences are highlighted in this table and minor differences were not specified.

INTERCHANGE GOETZE → PAYEN

Vergleichsliste Goetze → Payen • Références croisées Goetze → Payen
Intercambio entre Goetze y Payen

GOETZE	Payen	GOETZE	Payen	GOETZE	Payen	GOETZE	Payen
20-21835-01/0	GH856	20-27087-04/0	GV710	20-28382-01/0	GW722	21-24536-22/0	DM631
20-22547-03/0	GF051	20-27140-00/0	FB5100	20-28420-00/0	GW711	21-24565-22/0	CN306
20-22847-02/0	FX622	20-27140-01/0	FB5101	20-28420-01/0	GW712	21-24565-23/0	CN308
20-23114-03/0	GH795	20-27140-02/0	FB5102	20-28420-02/0	GW713	21-24578-22/0	DK480
20-24033-01/0	GK470	20-27162-00/0	GT340	20-28472-00/0	GK573	21-24586-24/0	DG050
20-24142-02/0	GL993 -CHG	20-27165-00/0	GT260	20-28607-00/0	FY690	21-24586-25/0	DG052
20-24160-01/0	GE220	20-27185-00/0	GV670	20-28607-01/0	FY691	21-24666-23/0	DL551
20-24160-02/0 +TC Felt	GE221	20-27265-00/0	GW280	20-28748-00/0	GY390	21-24666-24/0	DL550
20-24166-04/0	GE230	20-27266-00/0	FY610	20-28748-01/0	GY391	21-24666-25/0	DL551
20-24362-02/0	GE623	20-27271-00/0	GW410	20-28785-01/0	GY411	21-24669-24/0	DK643 +MG
20-24565-01/0	FN307	20-27378-00/0	GT300	20-28840-00/0	GW801	21-24669-25/0	DK640 +MG
20-24586-04/0	GG052	20-27426-00/0	FY291	20-29020-00/0	FY520	21-24669-26/0	DK642
20-24586-05/0	GH890	20-27604-01/0	GT840	20-29023-00/0	FY550	21-24669-27/0	DK641
20-24733-03/0	GH690	20-27608-01/0	GT830	20-29095-00/0	FA5560	21-24697-25/0	DD621
20-24764-03/0	GH681	20-27615-01/0	GT850	20-29319-00/0	FB5720	21-24764-24/0	DH681
20-25142-05/0	GR100	20-27740-00/0	GL600	20-29319-01/0	FB5721	21-24764-25/0	DH683
20-25202-02/0	GJ720	20-27776-02/0	FY811	20-29438-00/0	FA5130	21-24765-23/0	DM381
20-25236-01/0	GN621	20-27866-00/0	GR631	20-29634-00/0	FA5600	21-24775-21/0	DH080
20-25262-06/0	GT930	20-27866-01/0	GR632	20-29779-00/0	FD5970	21-24779-21/0	DJ852
20-25298-01/0	GG811	20-27867-00/0	GX390	20-29813-00/0	FY320	21-24813-26/0	DL571
20-25345-02/0	GK590	20-27867-01/0	GX391	20-29844-00/0	FE5240	21-24833-20/0	DC372
20-25767-02/0	GB131	20-27867-02/0	GX392	20-29887-00/0	FB5760	21-24853-22/0	DL561
20-25767-03/0	GB130	20-27867-03/0	GX410	20-29894-00/0	FB5750	21-24949-21/0	DM940
20-25842-02/0	GG452	20-27996-01/0	GP571	21-18032-26/0	DF351	21-24963-20/0	DN150 +CHG
20-25850-01/0	GK572	20-27997-01/0	GP601	21-20233-21/0	CV480	21-24964-20/0	DY740 +CHG
20-25850-02/0	GK570	20-27997-02/0	GP602	21-21887-20/0	DF106	21-24964-21/0	DJ441 +CHG
20-25893-02/0	GP861	20-28000-00/0	GR850	21-22641-20/0	CH851 +CHG	21-24964-22/0	DJ444 +CHG
20-25894-03/0	GP871	20-28001-00/0	GR960	21-22712-26/0	DN041	21-25122-21/0	DP790 +Carb. Gasket
20-26046-00/0	GP282	20-28007-00/0	GS950	21-22712-27/0	DN042	21-25128-24/0	DN010
20-26100-00/0	GT750 +O rings	20-28024-03/0	GY383	21-23007-23/0	DR010	21-25142-23/0	DR100
20-26294-01/0	GR630	20-28074-00/0	GJ501	21-23068-23/0	DJ160	21-25142-26/0	DV680
20-26479-01/0	GP68A	20-28082-00/0	GN200	21-23070-27/0	DK020	21-25148-26/0	CH865
20-26481-00/0	FN353	20-28083-00/0	GN390	21-23114-22/0	DH799	21-25148-40/0	CH864
20-26481-01/0	FN355	20-28093-00/0	GR750	21-23114-23/0	DH798	21-25202-22/0	DJ720
20-26522-01/0	GR611	20-28097-00/0	GS060	21-23235-26/0	DL580	21-25204-21/0	DN590 +IMG
20-26647-00/0	GT441	20-28102-00/0	GS870	21-23271-21/0	DH860	21-25204-22/0	DS820
20-26647-01/0	GT444	20-28120-00/0	GH740	21-23485-23/0	DM541	21-25204-23/0	CY082
20-26647-02/0	GT440	20-28123-00/0	GT900	21-23518-21/0	DL560	21-25204-24/0	CY131
20-26647-03/0	GT446	20-28124-02/0	GN481	21-23756-21/0	DC240	21-25204-25/0	DY310
20-26647-10/0	GT445	20-28125-00/0	GS600	21-23775-21/0	DF580	21-25236-21/0	DN621
20-26647-11/0	GT449	20-28127-00/0	GL390	21-24033-26/0	DK470	21-25262-23/0	DT930
20-26722-01/0	GN220	20-28127-01/0	GL391	21-24033-30/0 +Extra VCG	DK471	21-25298-21/0	DG811
20-26723-00/0	GH062	20-28197-01/0	GS241	21-24067-21/0	DC820	21-25319-21/0	DJ872
20-26724-01/0	GJ600	20-28203-00/0	GS120	21-24118-23/0	DP060	21-25345-22/0	DP293
20-26733-00/0	GM761	20-28204-01/0	GL281	21-24142-22/0	DL993	21-25345-23/0	DP292
20-26740-01/0	GL761	20-28206-01/0	GR561	21-24150-25/0	DG120	21-25413-21/0	DT420
20-26743-02/0	GL742	20-28224-00/0	GT430	21-24160-21/0	DE220	21-25413-23/0	DT411
20-26758-01/0	GL951	20-28225-00/0	GS130	21-24165-21/0	DE240	21-25499-27/0	DN663
20-26759-00/0	GN530	20-28226-00/0	GJ897	21-24166-21/0	DE230	21-25662-25/0	DJ170
20-26839-02/0	GB141	20-28232-01/0	GM891	21-24169-21/0	DK210	21-25662-26/0	DJ171
20-26849-00/0	GT570	20-28243-00/0	GP960	21-24169-22/0	DK211	21-25662-27/0	DJ172
20-27085-01/0	GH146	20-28244-00/0	GP970	21-24240-23/0	DR012 -CHG	21-25706-25/0	DP802
20-27085-02/0	GH145	20-28267-00/0	GV250	21-24244-34/0	DE051	21-25706-26/0	DP800
20-27085-03/0	GV520	20-28329-00/0	GK500	21-24362-21/0	DE622	21-25706-30/0	DP806
20-27087-02/0	GH159	20-28381-00/0	GX030	21-24362-22/0	DE623	21-25716-20/0	DW390
20-27087-03/0	GV711	20-28382-00/0	GW724	21-24424-23/0	DG640	21-25716-21/0	DG080

GOETZE	Payen	GOETZE	Payen	GOETZE	Payen	GOETZE	Payen
21-25716-22/0	DG082	21-26512-22/0	DX480	21-27271-20/0	DW410	21-27987-20/0	DY250
21-25716-23/0	DG083	21-26522-20/0	DP011	21-27343-20/0	DY370	21-27987-21/0	DY251
21-25729-40/0	DT482	21-26535-40/0	DL491	21-27343-21/0	DY371	21-27987-22/0	DY253
21-25753-27/0	DD502	21-26590-21/0	DW470	21-27344-20/0	DY360	21-27987-23/0	DY254
21-25818-22/0	DP810	21-26590-22/0	DW472	21-27344-21/0	DY362	21-27987-24/0	DY255
21-25818-23/0	DP811	21-26590-23/0	DW473	21-27359-20/0	DN150	21-27991-20/0	CJ631
21-25818-24/0	DP814	21-26602-20/0	CD5020	21-27376-21/0	DX652	21-27996-20/0	DP570
21-25819-21/0	DP820	21-26613-23/0	DL910	21-27378-20/0	DT300	21-27996-21/0	DP571
21-25819-23/0	DP825	21-26632-21/0	DL961	21-27427-21/0	DY260	21-27997-22/0	DP602
21-25842-21/0	DG452	21-26632-23/0	DY040	21-27445-20/0	DW330 +Oil Seals	21-27999-22/0	DR732
21-25850-21/0	DK570	21-26647-21/0	DT441	21-27452-20/0	DW320	21-28000-20/0	DR850
21-25873-20/0	DW260	21-26647-23/0	DT446	21-27452-21/0	DW322	21-28005-20/0	DS280
21-25873-23/0	DW261	21-26647-26/0	DT442	21-27510-20/0	DW861	21-28006-20/0	DS940
21-25874-20/0	DW300	21-26647-27/0	DT447	21-27518-20/0	CY640	21-28007-20/0	DS950
21-25893-22/0	DP861	21-26647-30/0	DT449	21-27529-20/0	DX090	21-28008-21/0	DS953
21-25893-23/0	DP860	21-26693-20/0	DT400	21-27560-20/0	DV150	21-28009-20/0	DV110
21-25894-22/0	DP871	21-26709-40/0	DX550	21-27575-20/0	DX651	21-28024-22/0	DY382
21-25894-23/0	DP870	21-26714-22/0	DM995	21-27577-20/0	DV190	21-28024-23/0	DY383
21-25909-20/0	BE940	21-26717-21/0	DL320	21-27578-20/0	DN360	21-28029-20/0	CB5140
21-25909-22/0	CZ030	21-26719-23/0	DN233	21-27588-20/0	DM850	21-28029-21/0	CB5141
21-25917-21/0	CA3130	21-26720-23/0	DK410	21-27593-20/0	DX580	21-28035-20/0	DS560
21-25950-21/0	DT290	21-26721-21/0	DM830	21-27604-20/0	DT840	21-28035-21/0	DS561
21-26004-56/0	DH870	21-26723-23/0	DH061	21-27604-21/0	DT840	21-28067-20/0	DC993
21-26016-20/0	DT360	21-26724-21/0	DJ601	21-27608-20/0	DT830	21-28079-20/0	DL340
21-26017-21/0	DP990	21-26724-22/0	DJ600	21-27615-20/0	DT850	21-28081-21/0	DM881
21-26027-20/0	DT500	21-26737-25/0	DK449	21-27682-20/0	DY241	21-28081-22/0	DM883
21-26027-21/0	DT510 +CHG	21-26737-26/0	DK446	21-27682-21/0	DY240	21-28082-20/0	DN200
21-26037-23/0	DE588	21-26758-23/0	DL951	21-27690-20/0	DY270	21-28087-20/0	DR250
21-26045-20/0	DP660	21-26839-21/0	DV270	21-27690-21/0	DY271	21-28088-20/0	DR270
21-26046-20/0	DP282	21-26844-21/0	DS731	21-27690-22/0	DY272	21-28090-21/0	DR332
21-26100-21/0	DP273	21-26849-21/0	HL605	21-27713-20/0	DR402	21-28092-21/0	DR581
21-26142-21/0	DT270	21-26850-20/0	DS810	21-27740-22/0	DL602	21-28093-20/0	DR750
21-26185-25/0	DK440	21-26851-20/0	DT010	21-27753-23/0	DG186	21-28097-20/0	DS060
21-26198-20/0	DL011	21-26853-20/0	DT012	21-27776-22/0	CY811	21-28103-20/0	DS970
21-26212-22/0	DK100	21-26853-21/0	DY130	21-27846-20/0	CC5690	21-28106-20/0	DV360
21-26280-20/0	DT350	21-26853-22/0	DT013	21-27849-20/0	DY300	21-28107-20/0	DV370
21-26294-21/0	DR630	21-26980-21/0	DX610	21-27849-21/0	DY301	21-28118-20/0	DS700
21-26295-21/0	DR620	21-27064-20/0	DG173	21-27850-20/0	DX600	21-28123-20/0	DT900
21-26305-21/0	DN361	21-27085-21/0	DH146	21-27866-20/0	DR631	21-28124-21/0	DN481
21-26310-22/0	DS720	21-27085-22/0	DH145 +O rings	21-27866-21/0	DR632	21-28124-22/0	DN482
21-26326-22/0	DM840	21-27085-23/0	DV520	21-27867-20/0	DX390	21-28125-20/0	DS600
21-26329-21/0	DS260	21-27087-22/0	DH157	21-27867-21/0	DX391	21-28126-20/0	DM910
21-26329-22/0	DS261	21-27087-23/0	DV711	21-27867-22/0	DX392	21-28126-21/0	DM911
21-26329-23/0	DS265	21-27095-21/0	DT562	21-27867-23/0	DX400	21-28127-20/0	DL390
21-26435-20/0	DD071	21-27095-22/0	DT561	21-27876-20/0	DZ490	21-28127-21/0	DL391
21-26435-21/0 Astadur	DD070 Non-Astadur	21-27127-20/0	DL916	21-27879-20/0	DL012	21-28137-20/0	DR540
21-26435-22/0	DD073	21-27141-20/0	DS381	21-27902-20/0	DC240	21-28143-21/0	DV351
21-26446-23/0	DX721	21-27162-20/0	DT340	21-27902-21/0	DT110 +CHG	21-28146-20/0	DV020
21-26446-24/0	DX720	21-27165-20/0	DT260	21-27959-20/0	DX620	21-28150-20/0	DS881
21-26448-21/0	DT193	21-27185-00/0	DV675	21-27985-21/0	CY210	21-28158-20/0	DR650
21-26479-24/0	DP688	21-27185-20/0	DV670	21-27985-22/0	CY211	21-28175-20/0	DN330
21-26479-26/0	DT410	21-27185-22/0	DV672	21-27986-20/0	DY230	21-28197-21/0	DS241
21-26481-20/0	CN353	21-27215-20/0	DW170	21-27986-21/0	CY220	21-28200-20/0	DR600
21-26481-21/0	CN355	21-27217-54/0	DW373	21-27986-22/0	CY221	21-28203-20/0	DS120
21-26496-20/0	DT140	21-27265-20/0	DW280	21-27986-23/0	DY231	21-28204-20/0	DL280
21-26496-21/0	DY671	21-27266-20/0	DW281	21-27986-25/0	DY232	21-28206-21/0	DR561

INTERCHANGE GOETZE → PAYEN

Vergleichsliste Goetze → Payen • Références croisées Goetze → Payen
Intercambio entre Goetze y Payen

GOETZE	Payen	GOETZE	Payen	GOETZE	Payen	GOETZE	Payen
21-28224-20/0	DT430	21-28797-20/0	DY030	21-29470-22/0	CC5262	21-29824-20/0	CD5220
21-28225-20/0	DS130	21-28799-21/0	CV940	21-29482-20/0	CA5830	21-29824-21/0	CD5221
21-28226-20/0	DJ898	21-28811-20/0	CC5890	21-29483-20/0	CC5060	21-29832-20/0	CE5180
21-28239-20/0	DR160	21-28820-20/0	DY660	21-29484-20/0	CC5010	21-29832-21/0	CE5181
21-28243-20/0	DP960	21-28820-30/0	CB5130	21-29489-20/0	CC5920	21-29844-20/0	CE5240 +VSS
21-28244-20/0	DP970	21-28840-21/0	DW801	21-29490-20/0	CA5940	21-29856-00/0	CA5010
21-28250-20/0	DG724	21-28889-20/0	DW540	21-29526-20/0	CC5860	21-29870-20/0	CE5320
21-28254-20/0	DT050	21-28934-20/0	DX630	21-29532-20/0	CC5630	21-29887-20/0	CB5760
21-28256-21/0	DM292	21-28939-20/0	DY070	21-29533-20/0	CC5550	21-29894-20/0	CB5750
21-28257-20/0	DM580	21-28952-20/0	DT800	21-29534-20/0	CC5580	21-29903-20/0	CY470
21-28257-21/0	DM581	21-28952-21/0	DT806	21-29536-20/0	CC5720	21-29904-21/0	CE5521
21-28258-21/0	DS771	21-28952-22/0	DT803	21-29543-20/0	DT071	21-29904-22/0	CE5522
21-28261-21/0	DR662	21-28952-23/0	DT805	21-29543-21/0	DT072	21-29904-23/0	CE5523
21-28267-20/0	DV250	21-28952-24/0	DT804	21-29554-20/0	DW642	21-29996-20/0	CE5920
21-28321-20/0	DP920	21-28997-20/0	CY830	21-29554-21/0	DW643	21-29999-20/0	CE5930 +IMG
21-28342-20/0	DR190	21-29006-20/0	CY910	21-29569-20/0	DZ440	21-30139-00/0	CG6220
21-28348-21/0	DM370	21-29011-20/0	CB5670	21-29572-20/0	CC5700	21-30140-00/0	CG7310
21-28351-21/0	DR991 -VCG	21-29011-21/0	CB5671	21-29574-20/0	CC5562	21-30143-00/0	CG7380
21-28364-20/0	DR360	21-29015-20/0	CE5200	21-29611-20/0	CC5500	21-30144-00/0	CG7390
21-28374-20/0	CA5620	21-29020-20/0	CY520	21-29611-21/0	CC5501	21-30146-00/0	CG7410
21-28380-20/0	DX040	21-29023-20/0	CY550	21-29611-22/0	CC5502	21-30305-00/0	DW5757
21-28381-20/0	DX030	21-29064-20/0	CA5420	21-29615-20/0	CC5600	21-30341-00/0	CG9560
21-28382-20/0	DW720	21-29064-21/0	CA5421	21-29615-21/0	CC5601	21-30342-00/0	CG9570
21-28382-21/0	DW721	21-29093-20/0	CA5561	21-29615-22/0	CC5602	21-30344-00/0	CG9580
21-28382-22/0	DW722	21-29093-21/0	CA5560	21-29615-23/0	CC5603	21-30345-00/0	CG9590
21-28382-23/0	DW723	21-29101-00/0	CE5950	21-29634-20/0	CA5600	21-30366-00/0	CH5030
21-28390-20/0	CB5241	21-29180-20/0	DZ720	21-29642-20/0	CB5230	21-30366-01/0	CH5031
21-28390-21/0	CB5240	21-29200-20/0	CB5360	21-29654-20/0	CD5690	22-11002B	HBS065
21-28420-20/0	DW710	21-29209-20/0	CB5540	21-29688-20/0	DY470	22-11003B	HBS068
21-28420-21/0	DW711	21-29248-00/0	CB5120	21-29688-21/0	DV720	22-11004B	HBS069
21-28420-22/0	DW712	21-29249-00/0	CB5131	21-29712-20/0	CY200	22-11005B	HBS066
21-28423-20/0	DW630	21-29249-10/0	CB5132	21-29715-20/0	DR290 +VSS	22-11006B	HBS121
21-28423-21/0	DW631	21-29263-30/0	CC5620 +VCG	21-29739-20/0	CD5750	22-11007B	HBS067
21-28472-20/0	DK573	21-29266-20/0	CA5780	21-29740-20/0	CD5760	22-11035B	HBS070
21-28578-20/0	CA5630	21-29270-20/0	CB5400	21-29743-20/0	CC5100	22-11036B	HBS041
21-28579-20/0	CY260	21-29276-20/0	CB5080	21-29745-20/0	DW050	22-11037B	HBS071
21-28596-20/0	CA5920	21-29277-00/0	CD5130	21-29747-20/0	DV530	22-11039B	HBS413
21-28607-20/0	CY680	21-29278-00/0	CD5140	21-29747-21/0	DL630	22-11040B	HBS467
21-28648-20/0	DT752	21-29292-20/0	DW750	21-29752-20/0	DY140	22-11041B	HBS468
21-28653-20/0	DZ960	21-29292-21/0	DW754	21-29762-20/0	CD5800	22-14603-04/0	ES450
21-28674-20/0	CC5460	21-29292-22/0	DW755	21-29766-20/0	CD5840	22-15001B	HBS082
21-28680-20/0	CB5420	21-29292-23/0	DW756	21-29773-20/0	CD5910	22-15002B	HBS083
21-28680-21/0	CB5421	21-29292-24/0	DW757	21-29778-20/0	CD5960	22-15003B	HBS038
21-28682-20/0	CB5440 +Oil Seals	21-29315-21/0	CC5441	21-29779-20/0	CD5970	22-15005B	HBS084
21-28707-20/0	DZ790	21-29319-20/0	CB5720	21-29780-20/0	CD5980	22-15006B	HBS115
21-28748-21/0	DY391	21-29330-20/0	CB5570	21-29783-20/0	CD5190	22-15007B	HBS125
21-28754-20/0	DY650	21-29400-20/0	CC5800	21-29785-20/0	CD5180	22-15008B	HBS017
21-28754-21/0	DY651	21-29400-21/0	CC5801	21-29786-20/0	CE5010	22-15009B	HBS127
21-28757-20/0	DY150	21-29438-20/0	CA5130	21-29789-20/0	CD5490	22-15010B	HBS039
21-28759-20/0	CY130	21-29442-20/0	CB5900	21-29793-20/0	CE5050	22-15013B	HBS087
21-28759-21/0	CY080	21-29443-20/0	CB5901	21-29794-20/0	CE5060	22-15014B	HBS088
21-28759-22/0	DL651	21-29447-20/0	CA5970	21-29811-20/0	CE5110	22-15015B	HBS113
21-28766-20/0	DX560	21-29456-20/0	DZ690	21-29813-20/0	CY320	22-15016B	HBS089
21-28767-20/0	DX570	21-29459-20/0	CC5190	21-29818-20/0	CE5130	22-15017B	HBS114
21-28780-20/0	DW340	21-29470-20/0	CC5260	21-29818-21/0	CE5131	22-15018B	HBS359
21-28785-20/0	DY410 +O rings	21-29470-21/0	CC5261	21-29820-20/0	CE5150	22-17001B	HBS051

GOETZE	Payen	GOETZE	Payen	GOETZE	Payen	GOETZE	Payen
22-17003B	HBS092	22-23856-06/0	EX995	22-26026B	HBS475	22-28498-00/0	EK486
22-17005B	HBS093	22-23856-07/0	EW860	22-26065B	HBS047	22-28596-00/0	EA5920
22-17006B	HBS052	22-23925-04/0	EX934	22-26067B	HBS045	22-28635-00/0	EY050
22-17007B	HBS095	22-24158-04/0	EH445	22-26068B	HBS046	22-28750-00/0	EY650
22-17009B	HBS109	22-24159-01/0	EE210	22-26069B	HBS058	22-28758-00/0	EY130
22-17010B	HBS097	22-24159-02/0	ET830	22-26071B	HBS152	22-28793-00/0	EC130
22-17011B	HBS098	22-24159-03/0	EE211	22-26073B	HBS061	22-28798-00/0	EA220
22-17013B	HBS130	22-24161-01/0	EE220	22-26074B	HBS062	22-28811-00/0	EC5890
22-17014B	HBS131	22-24161-02/0	ET841	22-26075B	HBS063	22-28817-00/0	EC340
22-17015B	HBS132	22-24161-03/0	EE221	22-26077B	HBS226	22-28818-00/0	EY940
22-17016B	HBS133	22-24187-00/0	EE240	22-26125-00/0	EB960	22-28897-01/0	EC080
22-17018B	HBS227	22-24187-02/0	ET850	22-26131-01/0	EK482	22-28935-00/0	EA140
22-17019B	HBS247	22-24480-00/0	EA440	22-26274-00/0	EC010	22-28953-00/0	ET800
22-17020B	HBS251	22-24777-01/0	EG176	22-26329-00/0	HC5006	22-29001B	HBS036
22-17021B	HBS255	22-24893-01/0	EG920	22-26384-00/0	EM362	22-29004B	HBS160
22-17022B	HBS297	22-25002B	HBS366	22-26386-00/0	EG875	22-29005B	HBS035
22-17023B	HBS345	22-25003B	HBS367	22-26394-50/0	EY580	22-29006B	HBS112
22-17024B	HBS348	22-25004B	HBS472	22-26449-00/0	ET190	22-29007B	HBS161
22-17025B	HBS353	22-25005B	HBS473	22-26516-00/0	EA900	22-29009B	HBS003
22-17026B	HBS370	22-25011-00/0	EK481	22-26554-02/0	ET812	22-29010B	HBS163
22-17027B	HBS371	22-25011-03/0	EK480	22-26554-40/0	ET811	22-29011-00/0	EB5670
22-17028B	HBS464	22-25011-04/0	EK485	22-26590-00/0	EW470	22-29011-01/0	EB5671
22-17029B	HBS465	22-25142-00/0	EV684	22-26590-04/0	EW474	22-29011B	HBS164
22-17030B	HBS485	22-25198-00/0	EL650	22-26643-00/0	EX550	22-29012B	HBS055
22-18001B	HBS050	22-25198-01/0	EL890	22-26812-01/0	EH880	22-29013B	HBS054
22-18002B	HBS056	22-25198-02/0	EV150	22-26923-50/0	HC5005	22-29014B	HBS252
22-18003B	HBS032	22-25198-03/0	ES820	22-26944-01/0	EC790	22-29015B	HBS253
22-18004B	HBS057	22-25409-00/0	EA441	22-26944-02/0	EC791	22-29016B	HBS298
22-18005B	HBS008	22-25605-00/0	EH951	22-27095-00/0	ET560	22-29017B	HBS280
22-18007B	HBS033	22-25605-02/0	EH952	22-27185-00/0	EV670	22-29018B	HBS279
22-18008B	HBS031	22-25667-00/0	ET500	22-27194-00/0	ES260	22-29019B	HBS299
22-18008B(100)	HBS031(100)	22-25667-02/0	ET490	22-27194-01/0	EK484	22-29022B	HBS391
22-18009B	HBS136	22-25716-06/0	EZ196	22-27194-05/0	EK470	22-29023B	HBS438
22-18011B	HBS296	22-25716-07/0	EZ197	22-27194-07/0	EC040	22-29024B	HBS439
22-18083B	HBS001	22-25920-01/0	EA3130	22-27206-00/0	ES720	22-29025B	HBS416
22-18084B	HBS006	22-25957-00/0	EG340 +Connected Gasket	22-27206-01/0	EC100	22-29026B	HBS417
22-18085B	HBS007	22-26004B	HBS146	22-27206-02/0	EC101	22-29027B	HBS419
22-18086B	HBS078	22-26006B	HBS059	22-27206-03/0	EC102	22-29037-00/0	EE5220
22-18088B	HBS140	22-26007B	HBS060	22-27343-00/0	EY370	22-29064-00/0	EA5420
22-18089B	HBS243	22-26008B	HBS149	22-27376-00/0	EA5620 +WPG	22-29098B	HBS002
22-18093B	HBS358	22-26009B	HBS150	22-27392-00/0	EB950	22-29099B	HBS053
22-18094B	HBS368	22-26010B	HBS293	22-27452-00/0	EW320	22-29100B	HBS074
22-18095B	HBS369	22-26011B	HBS292	22-27510-00/0	EW861	22-29169-00/0	EB5240
22-18096B	HBS392	22-26012B	HBS291	22-27574-00/0	EL960	22-29175-00/0	EB5140
22-18097B	HBS415	22-26014B	HBS294	22-27589-00/0	EM850 +Oil Seals	22-29266-00/0	EA5780
22-19993-01/0	EC797	22-26015B	HBS349	22-27665-01/0	EY230	22-29271-00/0	EB5400
22-20005B	HBS287	22-26016B	HBS350	22-27665-02/0	EB5360	22-29276-00/0	EB5080
22-20006B	HBS286	22-26017B	HBS351	22-27665-03/0	EB5541	22-29293-00/0	ER320
22-20159-02/0	ET820	22-26018B	HBS352	22-27740-00/0	EL600	22-29294-00/0	ER321
22-20518-01/0	EH680	22-26019B	HBS380	22-27740-01/0	EL601	22-29294-01/0	ER322
22-21235-00/0	EW870	22-26020B	HBS463	22-27748-01/0	EZ193	22-29342-00/0	EB5150
22-21235-07/0	EJ160	22-26021B	HBS459	22-27849-00/0	EC350	22-29400-00/0	EC5800
22-22119-01/0	EX930	22-26022B	HBS460	22-27851-00/0	EC230	22-29444-00/0	EB5900
22-22677-00/0	EH850 +Connected Gasket	22-26023B	HBS457	22-28386-00/0	HC5007	22-29457-00/0	EZ690
22-22842-01/0	EG692	22-26024B	HBS458	22-28438-00/0	ET191	22-29462-00/0 +Oil Seals	EC5220
22-23830-00/0	EG340 +Connected Gasket	22-26025B	HBS474	22-28450-00/0	EW630	22-29474-00/0	EC5060

INTERCHANGE GOETZE → PAYEN

Vergleichsliste Goetze → Payen • Références croisées Goetze → Payen
Intercambio entre Goetze y Payen

GOETZE	Payen	GOETZE	Payen	GOETZE	Payen	GOETZE	Payen
22-29485-00/0	EZ720	22-39027B	HBS171	22-56010B	HBS257	22-76007B	HBS378
22-29488-01/0	EC5921	22-39030B	HBS360	22-70001B	HBS187	22-76008B	HBS379
22-29508-00/0	EA5970	22-39031B	HBS362	22-70002B	HBS188	22-76009B	HBS381
22-29508-01/0	EA5940	22-39032B	HBS364	22-70003B	HBS189	22-76010B	HBS382
22-29533-00/0	EC5550	22-39033B	HBS470	22-70004B	HBS110	22-76011B	HBS434
22-29534-00/0	EC5580	22-39034B	HBS461	22-70005B	HBS190	22-76012B	HBS435
22-29569-00/0	EZ440	22-39035B	HBS471	22-70006B	HBS111	22-76013B	HBS436
22-29569-01/0	EZ441	22-39036B	HBS479	22-70010B	HBS194	22-76015B	HBS454
22-29615-01/0	EC5601	22-42001B	HBS044	22-70011B	HBS195	22-76016B	HBS455
22-29632-00/0	EY671	22-43001B	HBS173	22-70012B	HBS374	22-76018B	HBS402
22-29671-00/0	ED5650	22-47001B	HBS174	22-70013B	HBS295	22-76019B	HBS403
22-29688-00/0	EY470	22-47005B	HBS175	22-70015B	HBS432	22-76020B	HBS387
22-29688-01/0	EY720	22-47007B	HBS303	22-70016B	HBS433	22-76022B	HBS440
22-29712-00/0	EY200	22-47008B	HBS427	22-70017B	HBS409	22-76024B	HBS421
22-29725-00/0	EY570	22-47009B	HBS426	22-70018B	HBS404	22-76025B	HBS478
22-29739-00/0	ED5750	22-47010B	HBS480	22-70019B	HBS443	22-76026B	HBS483
22-29745-04/0	EZ184	22-47011B	HBS481	22-70020B	HBS422	22-77001B	HBS285
22-29752-00/0	EY140	22-47012B	HBS482	22-71001B	HBS042	22-77004B	HBS377
22-29762-00/0	ED5800 -Oil Seals	22-51001B	HBS102	22-71002B	HBS197	22-79002B	HBS218
22-29773-00/0	ED5910	22-51003B	HBS177	22-71003B	HBS198	22-79005B	HBS405
22-29778-00/0	ED5960	22-51004B	HBS011	22-71005B	HBS200	22-89003B	HBS222
22-29789-00/0	ED5490	22-51005B	HBS104	22-71008B	HBS203	22-89004B	HBS223
22-29811-00/0	EE5110	22-51006B	HBS116	22-71014B	HBS209	22-89005B	HBS005
22-29824-00/0	ED5220	22-51008B	HBS120	22-71016B	HBS306	22-89005B(100)	HBS005(100)
22-29832-00/0	EE5180	22-51009B	HBS178	22-71017B	HBS312	22-89007B	HBS305
22-29832-01/0	EE5181	22-51010B	HBS119	22-71018B	HBS313	22-89008B	HBS224
22-29846-00/0	EE5250	22-51102B	HBS241	22-71019B	HBS314	22-89009B	HBS423
22-29904-00/0	EE5520	22-51103B	HBS244	22-71020B	HBS315	22-89010B	HBS484
22-30144-00/0	EG7390	22-51104B	HBS010	22-71021B	HBS385	23-17373-01/0	HC027
22-30146-00/0	EG7410	22-51106B	HBS302	22-71022B	HBS386	23-20161-01/0	HC288
22-30152-00/0	EG7450	22-51107B	HBS301	22-71023B	HBS441	23-21053-01/0	HC418
22-30373-00/0	ED5720	22-51108B	HBS310	22-71024B	HBS397	23-21237-01/0	HC417
22-33022B	HBS029	22-51109B	HBS372	22-71025B	HBS445	23-21243-01/0	HC295
22-33024B	HBS246	22-51110B	HBS373	22-71026B	HBS450	23-22677-00/0	HC285
22-33025B	HBS249	22-51111B	HBS431	22-71027B	HBS452	23-23528-00/0	HC355
22-33026B	HBS264	22-52001B	HBS179	22-71028B	HBS394	23-23528-01/0	HC385
22-33027B	HBS265	22-52002B	HBS180	22-71030B	HBS425	23-23528-02/0	HC452
22-33031B	HBS268	22-53001B	HBS229	22-72001B	HBS281	23-24480-00/0	HC440
22-33032B	HBS269	22-53004B	HBS015	22-72002B	HBS282	23-25719-00/0	HC366
22-33033B	HBS270	22-53005B	HBS016	22-72003B	HBS284	23-26826-01/0	JJ464
22-33034B	HBS300	22-53008B	HBS245	22-72004B	HBS283	23-27430-00/0	JJ460
22-33035B	HBS311	22-53009B	HBS254	22-73001B	HBS407	23-27731-00/0	HC484
22-33036B	HBS316	22-53010B	HBS259	22-73002B	HBS408	23-27891-00/0	JJ138
22-33037B	HBS361	22-53011B	HBS260	22-73003B	HBS447	24-19083-00/0	HL222
22-33038B	HBS363	22-53012B	HBS185	22-75001B	HBS211	24-23057-01/0	HL659
22-33039B	HBS466	22-53014B	HBS261	22-75005B	HBS289	24-23624-00/0	HL461
22-33040B	HBS476	22-53016B	HBS272	22-75006B	HBS288	24-23835-00/0	HL456
22-39001B	HBS043	22-53017B	HBS273	22-75007B	HBS406	24-24069-00/0	HL462
22-39002B	HBS024	22-53018B	HBS277	22-75008B	HBS420	24-24184-01/0	HA339
22-39003B	HBS021	22-53019B	HBS278	22-75009B	HBS477	24-24391-02/0	HT011
22-39004B	HBS028	22-53020B	HBS309	22-76001B	HBS215	24-24392-01/0	HT010
22-39005B	HBS022	22-56001B	HBS105	22-76002B	HBS216	24-24468-02/0(6)	HT004(1)
22-39010B	HBS064	22-56002B	HBS106	22-76003B	HBS217	24-24810-02/0	HR754
22-39011B	HBS075	22-56003B	HBS108	22-76004B	HBS307	24-24961-00/0	HL474
22-39012B	HBS077	22-56004B	HBS107	22-76005B	HBS308	24-25267-00/0	HR666
22-39024B	HBS018	22-56008B	HBS262	22-76006B	HBS354	24-26320-00/0	HM5070

GOETZE	Payen	GOETZE	Payen	GOETZE	Payen	GOETZE	Payen
24-26539-00/0	HL733	24-31947-90/0	HR5076	30-024410-10	BL080	30-025706-20	BP800
24-26683-00/0	HM5293	24-31950-70/0	HR5082	30-024411-10	BL090	30-025716-00	BW390
24-26766-00/0	HL502	24-31951-90/0	HR5087	30-024427-10	BH710	30-025729-00	BT480
24-26802-00/0	HT018	24-31952-10/0	HR5088	30-024523-10	AE5400	30-025818-10	BP810
24-27611-00/0	HT009	24-32371-30/0	HL5070	30-024565-10	AN300	30-025819-10	BP820
24-27613-00/0	HT003	24-32419-80/0	HT020	30-024575-30	BP140	30-025842-10	BG450
24-27614-00/0	HT002	24-32448-70/0	HT019	30-024578-10	BK480	30-025872-20	BW270
24-27696-00/0	HM5294	24-35005-00/0	HT021	30-024666-10	BL550	30-025873-20	BW260
24-28044-00/0	HL509	24-35025-30/0	HT013	30-024669-10	BK640	30-025874-20	BW300
24-28574-00/0	HT5038	24-35025-31/0	HT014	30-024733-10	BH690	30-025875-20	BW310
24-28656-00/0	HA5040	24-35025-40/0	HT016	30-024764-10	BH680	30-025893-10	BP860
24-28657-00/0	HA5041	24-35025-41/0	HT017	30-024765-10	BM380	30-025894-10	BP870
24-28657-01/0	HA5042	24-35029-50/0	HT005	30-024772-10	BH080	30-026016-10	BT360
24-28782-00/0	HL701	24-35030-30/0	HT008	30-024773-10	BG900	30-026017-20	BP990
24-29152-00/0	HA5006	24-35030-60/0	HT022	30-024774-10	BH090	30-026021-10	BM580
24-29173-00/0	JD5245	24-35030-80/0	HT006	30-024779-10	BJ850	30-026044-10	BR470
24-29252-00/0	HA5005	24-35042-80/0	HA5029	30-024833-10	BC370	30-026045-10	BP660
24-29508-00/0	HC5004	24-35042-90/0	HA5030	30-024853-10	BL560	30-026046-30	BP280
24-29707-00/0	HA5010	24-35043-00/0	HA5031	30-024866-10	BR410	30-026080-00	BT520
24-29740-00/0	HM5064	24-35043-10/0	HA5032	30-024950-10	BM950	30-026081-00	BT510
24-29740-01/0	HA5015	25-24572-02/0	DL010	30-024951-10	BM960	30-026142-30	BD790
24-29740-02/0	HA5016	30-021834-40	AS450	30-025007-20	BK580	30-026144-10	BP890
24-29876-00/0	HA5020	30-021835-20	BH850	30-025008-20	BK570	30-026145-10	BP900
24-29902-00/0	HL5001	30-021839-10	AX660	30-025013-20	BP260	30-026146-10	BP910
24-30088-00/0	HL700	30-022199-20	BP070	30-025122-20	BY740	30-026177-10	AJ120
24-30258-00/0	HA5034	30-022269-30	AF240	30-025123-20	BJ440	30-026179-10	BJ430
24-30590-05/0	HR342	30-022291-40	AH750	30-025124-10	BL010	30-026185-10	BK440
24-30590-81/0	HR794	30-022666-20	AH850	30-025125-10	BL020	30-026208-10	BK110
24-30591-25/0	HR659	30-022712-20	BN040	30-025126-10	BL030	30-026239-10	BT530
24-30602-50/0	HR343	30-023070-20	BK020	30-025128-10	BN010	30-026267-10	BT470
24-30612-25/0(4)	HR631(8)	30-023114-20	BH790	30-025148-10	AH860	30-026280-10	BT350
24-30614-77/0	HL5002	30-023271-20	BH860	30-025150-10	BL400	30-026287-10	BM980
24-30637-41/0	HL196	30-023288-10	BP130	30-025152-10	BH950	30-026296-10	BV680
24-30653-84/0	HR5068	30-023485-20	BM540	30-025166-10	BT220	30-026296-20	AC5140
24-30656-05/0(8)	HR336(4)	30-023495-10	BF170	30-025167-10	BR690	30-026297-10	BV690
24-30676-75/0	HR5060	30-023518-20	BL560	30-025168-10	BT240	30-026297-20	AC5150
24-30676-76/0	HR5030	30-023670-10	BF290	30-025190-20	BN620	30-026298-10	BR700
24-30704-43/0	HR5057	30-023737-20	BN070	30-025210-20	BP030	30-026298-20	AC5160
24-30710-45/0	HR5080	30-023756-20	BC240	30-025236-20	BS460	30-026310-10	BS720
24-30715-70/0	HR5033	30-023852-10	BK490	30-025262-10	BT930	30-026329-10	BS260
24-30721-87/0	HR5081	30-024033-10	BK470	30-025301-20	BS010	30-026351-10	BM570
24-30725-37/0	HR5092	30-024115-10	BP510	30-025302-20	BS020	30-026353-10	BT190
24-30727-87/0	NA5133	30-024116-10	BE580	30-025303-20	BS030	30-026354-10	BT200
24-31919-10/0	HR599	30-024118-40	BP060	30-025345-10	BP290	30-026355-10	BT210
24-31919-11/0	HR599	30-024122-10 Astadur	AM870 Non-Astadur	30-025351-10	BP300	30-026435-00	BD070
24-31935-10/0	HR5064	30-024123-10 Astadur	AN400 Non-Astadur	30-025376-10	BM530	30-026446-10	BX720
24-31938-60/0	HR5048	30-024142-40	AN370	30-025413-10	BT420	30-026451-10	BJ860
24-31938-61/0	HR5096	30-024150-10	BG130	30-025499-10	BN660	30-026452-10	BJ870
24-31939-70/0	HR656	30-024160-00	BE220	30-025540-10	BN140	30-026453-10	BJ880
24-31939-80/0	HR752	30-024165-10	BE240	30-025645-10	BR070	30-026481-00	AN350
24-31939-81/0	HR5031	30-024166-10	BE230	30-025646-10	BW040	30-026495-00	BT110
24-31942-80/0	HR5044	30-024168-10	BD910	30-025657-10	BR010	30-026496-00	BT140
24-31944-50/0	HR5061	30-024169-00	BK210	30-025658-10	BR020	30-026512-00	BX480
24-31945-10/0	HR5063	30-024360-10	BG820	30-025659-10	BR030	30-026520-10	BP110
24-31945-40/0	HR5075	30-024361-10	BG830	30-025662-10	BJ170	30-026522-20	BP520
24-31947-50/0	HR5072	30-024362-10	BE620	30-025683-10	BR120	30-026530-10	AE5040

INTERCHANGE GOETZE → PAYEN

Vergleichsliste Goetze → Payen • Références croisées Goetze → Payen
Intercambio entre Goetze y Payen

GOETZE	Payen	GOETZE	Payen	GOETZE	Payen	GOETZE	Payen
30-026532-30	BT300	30-027147-10	AB5110	30-027706-00	AN450	30-028082-00	BN200
30-026533-30	BT310	30-027162-00	BT340	30-027707-00	AN360	30-028083-00	BN390
30-026534-30	BT320	30-027165-10 Astadur	BT260 Non-Astadur	30-027708-00	BC550	30-028085-00	BP530
30-026560-00	BT580	30-027171-10	BY070	30-027712-00	BR390	30-028086-00	BP650
30-026569-20	BP460	30-027185-00	BV670	30-027713-00	AY370	30-028087-00	BR250
30-026570-20	BP480	30-027215-00	BW170	30-027714-00	BD830	30-028088-00	BR270
30-026576-10	BS520	30-027265-00	BW290	30-027715-00	AY020	30-028090-00	BR330
30-026577-10	BS530	30-027266-00	BW280	30-027716-00	BW120	30-028092-00	BR580
30-026578-10	BS540	30-027271-00	BW410	30-027717-00	BS350	30-028093-00	BR750
30-026590-10	BW470	30-027343-20	BY370	30-027718-00	AN010	30-028098-00	BS290
30-026613-00	BL910	30-027344-20	BY360	30-027720-00	AL350	30-028102-00	BS870
30-026647-30	BT440	30-027359-00	BN150	30-027740-00	BL600	30-028103-00	BS970
30-026650-20	BP270	30-027376-10	BX650	30-027753-00	BG180	30-028104-00	BT130
30-026651-20	BR090	30-027381-00	AG7360	30-027847-00	BF600	30-028113-00	AY630
30-026654-20	AY300	30-027397-00	BV950	30-027848-00	BG540	30-028114-10	AY620
30-026655-20	AY310	30-027426-00	AY290	30-027849-00	BY300	30-028115-00	BN450
30-026693-10	BT400	30-027427-00	BY260	30-027850-00	BX600	30-028118-00	BS700
30-026713-10	BM920	30-027442-20	BW340	30-027854-30	BY410	30-028120-00	BH740
30-026714-10	BM990	30-027443-20	BW350	30-027855-30	BY420	30-028124-00	BN480
30-026716-10	BM300	30-027444-20	BW360	30-027856-30	BY430	30-028126-00	BM910
30-026717-10	BL320	30-027445-00	BW330	30-027859-00	BV700	30-028127-00	BL390
30-026719-10	BN230	30-027452-00	BW320	30-027859-20	AC5180	30-028137-00	BR540
30-026721-10	BM830	30-027479-00	BW650	30-027865-00	BR620	30-028143-00	BV350
30-026722-10	BN220	30-027492-10	BY330	30-027866-00	BR630	30-028146-00	BV020
30-026723-10	BH060	30-027493-10	BY340	30-027867-00	BX390	30-028150-00	BS880
30-026724-10	BJ600	30-027494-10	BY350	30-027868-00	BX400	30-028168-00	BV030
30-026733-10	BM760	30-027518-00	BT390	30-027876-10	BZ490	30-028175-00	BN330
30-026734-10	BP580	30-027518-10	AY640	30-027883-00	BX410	30-028197-00	BS240
30-026739-10	BJ360	30-027519-00	BT380	30-027884-00	BX420	30-028200-00	BR600
30-026740-10	BL760	30-027529-00	BX090	30-027892-10	AY590	30-028203-00	BS120
30-026751-10	BL300	30-027530-00	AB5800	30-027898-00	BW150	30-028204-00	BL280
30-026758-10	BL950	30-027531-00	AB5810	30-027925-00	AY930	30-028206-00	BR560
30-026759-10	BN530	30-027532-00	AB5820	30-027941-00	BY400	30-028209-00	BG740
30-026838-00	AZ020	30-027536-00	BW010	30-027959-00	BX620	30-028211-00	BN560
30-026839-10	BV270	30-027537-00	BW020	30-027985-00	AY210	30-028224-00	BT430
30-026845-20	BS730	30-027538-00	BW030	30-027986-00	BY230	30-028225-00	BS130
30-026849-00	BT570	30-027543-10	BY940	30-027987-10	BY250	30-028226-00	BJ890
30-026850-00	BS810	30-027543-20	BY941	30-027993-00	BL880	30-028239-00	BR160
30-026851-00	AD5700	30-027544-10	BY950	30-027996-00	BP570	30-028240-00	BS610
30-026855-10	BR790	30-027546-00	BV160	30-027997-00	BP600	30-028243-00	BP960
30-026858-10	BR510	30-027556-00	BS820	30-027999-00	BR730	30-028247-00	BM590
30-026859-10	BL650	30-027570-00	AF070	30-028000-00	BR850	30-028249-00	BS050
30-026869-10	BL830	30-027571-00	AF470	30-028001-00	BR960	30-028257-00	BM580
30-026911-00	BL710	30-027575-00	BV190	30-028004-00	BS070	30-028258-00	BS770
30-026968-10	BL960	30-027578-00	BN360	30-028005-00	BS280	30-028261-00	BR660
30-026969-10	BL970	30-027581-00	AK660	30-028006-00	BS940	30-028265-00	BS200
30-026980-00	BX610	30-027582-00	AF460 Copper CHG	30-028007-00	BS950	30-028267-00	BV250
30-027064-10	BG170	30-027588-00	BM850	30-028024-30	BY380	30-028270-00	BM570
30-027084-20	BV520	30-027604-00	BT840	30-028029-00	AB5140	30-028321-00	BP920
30-027085-20	BS340	30-027608-00	BT830	30-028035-00	BS560	30-028339-00	AY670
30-027086-10	BP490	30-027615-10	BT850	30-028039-00	BW630	30-028340-00	AY660
30-027087-10	BW160	30-027629-10	AC5450	30-028040-00	BW640	30-028341-00	AY650
30-027095-00	BT560	30-027682-00	BY240	30-028067-00	BC990	30-028342-00	BR190
30-027127-00	BX080	30-027690-00	BY270	30-028070-00	BD950	30-028348-00	BM370
30-027140-10	AB5100	30-027704-00	AN460	30-028077-00	BK680	30-028350-00	BR940
30-027141-10	AY580	30-027705-00	AN470	30-028081-00	BM880	30-028358-00	BM330

GOETZE	Payen	GOETZE	Payen	GOETZE	Payen	GOETZE	Payen
30-028364-00	BR360	30-028714-00	BY980	30-029099-00	BY130	30-029423-00	AA5960
30-028374-00	AA5620	30-028714-10	BY981	30-029101-00	AE5950	30-029424-00	AA5970
30-028380-00	BX040	30-028748-00	BY390	30-029110-00	AE5560	30-029425-00	AA5980
30-028381-00	BX030	30-028754-00	BY650	30-029163-00	AB5010	30-029426-00	AA5990
30-028382-00	BW720	30-028755-00	BY150	30-029164-00	AB5020	30-029438-00	AA5130
30-028387-10	BX550	30-028756-00	BY180	30-029165-00	AB5030	30-029439-00	AB5900
30-028389-10	BY640	30-028760-00	BV140	30-029190-00	AA5830	30-029440-00	AB5910
30-028390-20	AB5240	30-028761-00	BY310	30-029191-00	AA5840	30-029441-00	AB5920
30-028420-00	BW710	30-028762-00	AY090	30-029192-00	AA5850	30-029449-00	AC5110
30-028472-00	AY400	30-028767-00	BX570	30-029193-00	AA5860	30-029450-00	AC5120
30-028473-00	AY410	30-028797-00	BY030	30-029194-00	AA5870	30-029451-00	AC5130
30-028474-00	AY420	30-028799-00	BV940	30-029195-00	AA5880	30-029461-00	AC5210
30-028475-00	BX880	30-028811-00	AC5890	30-029196-00	AE5340	30-029467-00	AY610
30-028476-00	BX890	30-028820-00	BY660	30-029197-00	AE5350	30-029469-00	AC5260
30-028477-00	BX900	30-028827-00	AB5260	30-029198-00	AE5360	30-029470-00	AC5270
30-028478-00	BX910	30-028861-00	BW420	30-029199-00	AE5370	30-029473-00	AC5060
30-028479-00	BX920	30-028871-00	BV380	30-029200-00	AB5360	30-029473-10	AC5061
30-028484-00	BX830	30-028874-00	BP950	30-029209-00	AB5540	30-029474-00	AC5070
30-028485-00	BX840	30-028919-00	BT890	30-029229-00	AB5000	30-029475-00	AC5080
30-028486-00	BX850	30-028934-00	BX630	30-029239-00	AB5950	30-029476-00	AC5090
30-028487-00	BX860	30-028943-00	BY080	30-029242-00	AB5300	30-029477-00	AC5010
30-028488-00	BX870	30-028952-00	BT800	30-029243-00	AB5310	30-029478-00	AC5020
30-028498-00	AY160	30-028975-00	AY430	30-029244-00	AB5320	30-029479-00	AC5030
30-028499-00	AY170	30-028978-10	BE440	30-029245-00	AB5330	30-029479-10	AC5031
30-028500-00	AY180	30-028979-10	BE450	30-029246-00	AB5340	30-029480-00	AC5040
30-028503-00	BX930	30-028980-10	BE460	30-029247-00	AB5350	30-029481-00	AC5050
30-028504-00	BX940	30-028998-00	AY840	30-029248-00	AB5120	30-029481-10	AC5051
30-028505-00	BX950	30-028999-00	AY850	30-029249-00	AB5130	30-029486-00	AG8370
30-028506-00	BX960	30-029000-00	AY860	30-029250-00	AE5210	30-029487-00	AG8380
30-028507-00	BX970	30-029006-00	AY910	30-029254-00	AD5600	30-029488-00	AC5920
30-028536-00	BZ630	30-029007-00	AY900	30-029255-00	AD5610	30-029497-00	AG9490
30-028537-00	BZ640	30-029008-00	AY920	30-029262-00	AN110	30-029498-00	AC5390
30-028538-00	BZ650	30-029011-00	AB5670	30-029266-00	AA5780	30-029499-00	AC5400
30-028564-00	BZ690	30-029012-00	AB5680	30-029270-00	AB5400	30-029524-00	AC5870
30-028565-00	BZ700	30-029015-00	AE5200	30-029272-00	AG8320	30-029525-00	AC5880
30-028566-00	BZ710	30-029016-00	AY710	30-029275-00	AA5590	30-029526-00	AC5860
30-028578-00	AA5630	30-029017-00	AY720	30-029276-00	AB5080	30-029532-00	AC5630
30-028579-00	AY260	30-029018-00	AY730	30-029277-00	AD5130	30-029533-00	AC5550
30-028596-20	AA5920	30-029020-00	AY550	30-029278-00	AD5140	30-029534-00	AC5580
30-028607-00	AY680	30-029021-00	AY560	30-029279-00	AD5150	30-029535-00	AC5590
30-028608-00	AY690	30-029022-00	AY570	30-029280-00	AD5160	30-029536-00	AC5720
30-028609-00	AY700	30-029023-10	AY520	30-029281-00	AD5170	30-029543-00	BT070
30-028653-00	BZ960	30-029024-10	AY530	30-029282-00	AA5790	30-029544-00	AC5750
30-028661-00	BZ780	30-029025-10	AY540	30-029283-00	AA5800	30-029545-00	AC5760
30-028674-00	AC5460	30-029037-00	AE5220	30-029292-00	BW750	30-029546-00	AC5770
30-028677-00	AC5480	30-029057-00	AB5510	30-029316-00	AG8340	30-029554-00	AC5940
30-028680-00	AB5420	30-029058-00	AB5520	30-029317-00	AB5720	30-029569-00	BZ440
30-028681-00	AB5430	30-029059-00	AB5530	30-029318-00	AB5730	30-029570-00	BZ450
30-028682-00	AB5440	30-029064-00	AA5420	30-029319-00	AB5740	30-029571-00	BZ460
30-028683-00	AB5450	30-029066-00	AA5720	30-029342-00	AB5150	30-029572-00	AC5700
30-028707-00	BZ790	30-029067-00	AA5730	30-029400-00	AC5800	30-029574-00	AC5560
30-028708-00	BZ800	30-029068-00	AA5740	30-029401-00	AC5910	30-029588-00	AC5780
30-028709-00	BZ810	30-029072-00	AY320	30-029402-00	AC5680	30-029589-00	AC5790
30-028712-00	BY960	30-029093-10	AA5560	30-029406-00	AC5290	30-029593-00	AC5610
30-028712-10	BY961	30-029094-10	AA5570	30-029421-00	AA5940	30-029594-00	AL580
30-028713-00	BY970	30-029095-10	AA5580	30-029422-00	AA5950	30-029597-00	AL480

INTERCHANGE GOETZE → PAYEN

Vergleichsliste Goetze → Payen • Références croisées Goetze → Payen
Intercambio entre Goetze y Payen

GOETZE	Payen	GOETZE	Payen	GOETZE	Payen	GOETZE	Payen
30-029598-00	AL500	30-029799-00	AD5710	30-030188-00	AG5220	31-022554-00	JH494
30-029599-00	AN480	30-029800-00	BR490	30-030197-00	AG8790	31-022564-00(25)	KA293(20)
30-029600-00	AX850	30-029801-00	AY120	30-030198-00	AG8490	31-022641-20	JM510
30-029602-00	AD5020	30-029802-00	BY120	30-030213-00	AG8800	31-022642-10(5)	JA769(1)
30-029610-00	AC5510	30-029811-00	AE5110	30-030217-00	AG8840	31-022671-10(5)	JA770(1)
30-029611-00	AC5500	30-029819-00	AE5140	30-030218-00	AG8850	31-022672-10(5)	JA768(1)
30-029615-00	AC5600	30-029820-00	AE5150	30-030245-00	AG8930	31-022714-10(10)	JA777(5)
30-029637-00	AA5150	30-029821-00	AE5160	30-030247-00	AG8950	31-022715-10(10)	JB851(1)
30-029638-00	AA5510	30-029823-00	AE5170	30-030248-00	AG8960	31-022722-10(1)	JB855(8)
30-029640-00	AA5520	30-029824-00	AD5220	30-030256-00	AG8990	31-022812-10	JH858
30-029642-00	AB5230	30-029844-00	AE5240	30-030263-00	AG9030	31-022840-00	JM495
30-029647-00	AD5540	30-029847-00	AE5260	30-030286-00	AG9320	31-022845-10	KA289
30-029654-00	AD5690	30-029848-00	AE5270	30-030291-00	AG9350	31-022926-10	JN041
30-029687-00	BZ300	30-029849-00	AE5280	30-030305-00	BW5750	31-023007-10	JN521
30-029688-00	BY470	30-029850-00	AE5290	30-030314-00	AF5280	31-023086-00	JM669
30-029689-00	BY480	30-029851-00	AE5300	30-030341-00	AG9560	31-023120-10	JN068
30-029690-00	BY490	30-029856-00	AA5010	30-030342-00	AG9570	31-023163-10(1)	KA295(25)
30-029691-00	BY500	30-029870-00	AE5320	30-030344-00	AG9580	31-023208-10(1)	JB850(10)
30-029712-00	AY200	30-029887-00	AB5760	30-030345-00	AG9590	31-023336-10	JJ495
30-029735-00	BB240	30-029894-00	AB5750	30-030366-00	AH5030	31-023475-00	JH111
30-029739-00	AD5750	30-029903-00	AY470	31-013653-20	JM856	31-023565-10(10)	JE117(1)
30-029743-00	AC5100	30-029904-00	AE5520	31-016508-30	JM869	31-023576-10	JJ280
30-029744-00	AY070	30-029905-00	AE5530	31-017026-20	JB188	31-023715-00(10)	JE904(1)
30-029745-00	BW050	30-029906-00	AE5540	31-018363-10(5)	JB841(1)	31-023729-00(1)	JR349(10)
30-029746-00	AD5770	30-029928-00	AE5550	31-019993-30	PA815	31-023758-10(10)	JB862(1)
30-029747-00	BY530	30-029951-00	AG8470	31-020165-10(5)	JA415(1)	31-023762-20(25)	JB799(1)
30-029749-00	AD5030	30-029952-00	AG8480	31-020233-20(25)	JB373(1)	31-023856-10	JJ184
30-029750-00	AD5040	30-029953-00	AG8430	31-020446-20	JN299	31-023881-20	JD172
30-029751-00	AD5050	30-029954-00	AG8440	31-020447-30	JJ089	31-023925-20	JJ104
30-029752-00	BY140	30-029971-00	AG6050	31-020518-00(10)	JR635(1)	31-023963-00	JN229
30-029762-00	AD5800	30-029972-00	AG6060	31-021018-10(10)	JA499(1)	31-024039-00(5)	JE689(1)
30-029763-00	AD5810	30-029973-00	AG7300	31-021029-00	JM333	31-024158-10	JJ065
30-029764-00	AD5820	30-029986-00	AE5730	31-021036-00(1)	KS617(10)	31-024161-10	JJ141
30-029765-00	AD5830	30-029987-00	AE5740	31-021055-10	JM875	31-024187-10	JJ475
30-029766-00	AD5840	30-029996-00	AE5920	31-021055-20	JM875	31-024200-10(10)	JE248(1)
30-029767-00	AD5850	30-029999-00	AE5930	31-021055-30	JN616	31-024212-10(1)	LR902(10)
30-029768-00	AD5860	30-030035-00	AG9430	31-021058-20(5)	JC155(1)	31-024269-10	JR5039
30-029769-00	AD5870	30-030036-00	AG9440	31-021550-10(1)	KT639(10)	31-024274-10(25)	JC054(10)
30-029773-00	AD5910	30-030037-00	AG9450	31-021632-10	JE390	31-024299-00	JN344
30-029774-00	AD5920	30-030051-00	AG8410	31-021753-00	JM085	31-024300-10(25)	JC149(1)
30-029775-00	AD5930	30-030052-00	AG8420	31-021833-10	JC973	31-024312-10	JC281
30-029777-00	AD5950	30-030086-00	AA5530	31-021849-10(5)	JE555(1)	31-024313-10(10)	JC280(1)
30-029778-00	AD5960	30-030087-00	AA5540	31-021852-60	JM508	31-024323-30	LB955
30-029779-00	AD5970	30-030120-00	AF5990	31-021887-00	JN238	31-024376-10(25)	JC929(1)
30-029780-00	AD5980	30-030123-00	AG5000	31-021888-10(1)	JB837(5)	31-024452-10	JC364
30-029781-00	AD5990	30-030139-00	AG6220	31-022026-20	JP004	31-024454-10	JC363
30-029783-00	AD5190	30-030140-00	AG7310	31-022172-00	JN013	31-024472-10	JD498
30-029785-00	AD5180	30-030143-00	AG7380	31-022174-00	JM478	31-024473-20(5)	JC790(1)
30-029786-00	AE5010	30-030144-00	AG7390	31-022175-10	JN260	31-024515-00	JE138
30-029787-00	AE5020	30-030145-00	AG7400	31-022193-10(1)	JE647(10)	31-024520-00(10)	JE119(1)
30-029789-00	AD5490	30-030146-00	AG7410	31-022278-00	JA829	31-024532-10	JD297
30-029790-00	AD5500	30-030147-00	AG7420	31-022293-10(25)	JB811(1)	31-024546-30	KK5681
30-029791-00	AD5510	30-030148-00	AG7430	31-022298-10(10)	JA613(1)	31-024572-00	JN453
30-029792-00	AD5520	30-030149-00	AG7440	31-022346-10	JA757	31-024625-20(5)	JC282(1)
30-029793-00	AE5050	30-030170-00	AG8310	31-022399-10	JM956	31-024668-10	JJ489
30-029794-00	AE5060	30-030183-00	AD5340	31-022534-00	JM986	31-024675-10	JD071

GOETZE	Payen	GOETZE	Payen	GOETZE	Payen	GOETZE	Payen
31-024680-00(10)	JJ136(5)	31-025684-10(5)	JD291(1)	31-026340-10(25)	JA899(10)	31-027151-00	JF150
31-024682-10(5)	JC137(10)	31-025685-20(25)	JD315(1)	31-026384-10	JR596	31-027178-00	JE5075
31-024685-10(1)	LT021(10)	31-025755-20	JD278	31-026392-00	JN635	31-027191-10(5)	JC823(1)
31-024732-00	JM663	31-025762-00	JE5073	31-026394-10	JJ500	31-027193-00(1)	JD198(10)
31-024743-00(50)	PA127(100)	31-025771-00(50)	JD5271(6)	31-026396-10	LT384	31-027194-00	JH5005
31-024767-00	JE120	31-025774-10(2)	JC694(5)	31-026432-00	JN279	31-027196-00	JE5028
31-024775-10	JN697	31-025811-00	JE5074	31-026434-00(25)	JB917(1)	31-027206-00	JJ459
31-024851-00	LT839	31-025817-10(10)	JC757(1)	31-026439-00	KK5683	31-027221-10(5)	JD146(1)
31-024854-10(5)	JC437(1)	31-025820-20(10)	JC756(1)	31-026441-00	JE5018	31-027225-00	JN643
31-024861-10	JN849	31-025849-10(4)	JD025(10)	31-026443-10	JD169	31-027255-10	JH5115
31-024869-00(5)	JE160(10)	31-025850-10	JP067	31-026450-00(5)	JD240(1)	31-027272-00	JD152
31-024875-10(5)	JD237(1)	31-025852-10(25)	JC928(5)	31-026455-10	JD021	31-027274-00	JN812
31-024888-10	JE5026	31-025855-00	JJ080	31-026467-10	JH5113	31-027276-00	JD015
31-024893-10	JJ551	31-025868-10(120)	JC238(2)	31-026472-00	JD327	31-027279-00(1)	JD222(10)
31-024963-40	JN620	31-025888-00(5)	JD430(1)	31-026474-20(5)	JD246(1)	31-027280-00	JN807
31-024964-10	JN332	31-025903-00(1)	LV695(10)	31-026476-10(5)	JD187(1)	31-027281-00	JN808
31-024970-20	JB162	31-025904-00(1)	JR673(10)	31-026514-00(5)	JD009(1)	31-027287-00	JD223
31-024992-10	JN942	31-025906-00(1)	JJ359(10)	31-026516-10	JJ183	31-027293-00(5)	JD345(1)
31-025011-00	JJ200	31-025907-10(5)	JD148(10)	31-026549-00	KK5684	31-027300-00	JD018
31-025031-10(25)	JC055(10)	31-025922-10(25)	JC660(20)	31-026554-10	JJ140	31-027310-00(5)	JD160(1)
31-025050-20	JJ542	31-025930-10	JD5913	31-026554-50	JH5114	31-027311-00	JJ499
31-025054-00	JD124	31-025935-10(1)	LT439(20)	31-026584-00	JN789	31-027314-00(30)	JC692(5)
31-025060-10	JJ490	31-025939-10(1)	JR749(10)	31-026592-10(5)	JD411(1)	31-027315-00	JJ413
31-025062-10	JC386	31-025950-10	JN568	31-026593-10	JD410	31-027321-00	JD153
31-025070-00	JF205	31-025952-10(1)	JJS081(10)	31-026604-00(5)	JD028(1)	31-027331-00	JD151
31-025104-10(10)	JC565(1)	31-025968-10(1)	OK473(10)	31-026620-10(5)	JC669(1)	31-027351-00(10)	JD482(1)
31-025105-10	JE5022	31-025988-00	PA817	31-026628-10(5)	JD409(1)	31-027352-00(5)	JD483(1)
31-025107-00(10)	JD119(6)	31-025992-00	JH5056	31-026640-00(5)	JD543(1)	31-027379-00	JJ398
31-025140-10	JN644	31-025993-10	JH5111	31-026671-00	JJ538	31-027428-00	JN948
31-025142-10	JN459	31-026027-00	JN662	31-026682-00	JN302	31-027441-00	JN645
31-025143-10	JC287	31-026039-00(25)	JC707(10)	31-026695-10(10)	JF191(1)	31-027448-00	JD225
31-025146-10(1)	LA057(10)	31-026040-10	JN796	31-026711-00(5)	JD542(1)	31-027450-10	JD271
31-025147-10(25)	LT498(10)	31-026047-10(1)	KT754(10)	31-026727-00(5)	JC243(1)	31-027451-00	JD227
31-025159-10(10)	JD5746(1)	31-026050-10(2)	JC662(5)	31-026812-00	JJ488	31-027453-00	JD067
31-025164-10	JN588	31-026083-00	JD5268	31-026819-00	JN805	31-027459-00	JD456
31-025174-00(5)	JD301(1)	31-026084-00(25)	JE5020(1)	31-026820-00	JP049	31-027474-00(1)	LA190(10)
31-025183-10(10)	JC283(1)	31-026099-10	JN626	31-026822-00(1)	LA378(10)	31-027488-00	JJ366
31-025198-10	JJ283	31-026102-00	JJ317	31-026823-00	JJ374	31-027495-00	JJ440
31-025199-10(25)	JC423(2)	31-026125-10	LT043	31-026835-10	JD221	31-027514-00	JD603
31-025205-20(24)	JC415(4)	31-026127-00	LT045	31-026841-00	JJ491	31-027523-00(1)	JF123(10)
31-025215-00	JN369	31-026143-10	JD017	31-026846-00(5)	JD309(1)	31-027540-00	JD529
31-025293-10(1)	LV582(10)	31-026150-10(2)	JC091(2)	31-026847-00	JD310	31-027564-00(5)	JD490(1)
31-025294-10(25)	LV589(10)	31-026152-10(5)	JD283(1)	31-026880-00(10)	JD282(1)	31-027565-00(10)	JD608(1)
31-025295-10(1)	LV583(10)	31-026153-00	JD189	31-026898-00(5)	JC261(1)	31-027568-00	JM302
31-025319-00	JN669	31-026160-10	JJ537	31-026923-00	JJ498	31-027573-00	JD419
31-025324-10	JD239	31-026161-00	JH5112	31-026943-00	JF206	31-027589-00	JH409
31-025331-10(10)	JC440(1)	31-026163-00(5)	JE5019(1)	31-026944-00	JH683	31-027616-00	JJ476
31-025367-10	KS696	31-026183-00	JM008	31-026946-00	JJ543	31-027625-00	JD5210
31-025407-20(10)	JD114(1)	31-026198-10	JN693	31-026962-00	JD584	31-027684-00	JD450
31-025415-10(2)	JD5765(1)	31-026240-10	JC497	31-026982-00(5)	JD587(10)	31-027684-10	JD5300
31-025623-00	JJ519	31-026277-00	JD602	31-027032-10	JD019	31-027686-00	JD457
31-025629-10(1)	JR580(5)	31-026290-10(2)	JC738(5)	31-027042-00	JJ501	31-027688-00(5)	JD458(1)
31-025636-00(25)	KA546(10)	31-026292-20	KK5682	31-027055-00(5)	JC724(1)	31-027689-00	JH5052
31-025650-10(1)	KL221(10)	31-026319-00(5)	JD565(10)	31-027056-00(10)	JD188(1)	31-027698-00	JD459
31-025652-10	JD143	31-026334-00	JC824	31-027094-00	JD348	31-027699-00(5)	JD451(1)
31-025656-10(5)	JC829(1)	31-026335-10	JD455	31-027096-20	JJ536	31-027700-00	JD5201

INTERCHANGE GOETZE → PAYEN

Vergleichsliste Goetze → Payen • Références croisées Goetze → Payen
Intercambio entre Goetze y Payen

GOETZE	Payen	GOETZE	Payen	GOETZE	Payen	GOETZE	Payen
31-027729-00(5)	JD273(1)	31-028604-00	JA5043	31-029298-00	JD656	31-029698-00	JH5065
31-027737-00	JJ069	31-028635-00	JH5118	31-029299-00	JD654	31-029702-00(1)	JE5050(5)
31-027751-00	JN346	31-028656-00(10)	JA5042(1)	31-029301-00	JD655	31-029704-00	JA5001
31-027778-00	JD5914	31-028657-00	JA5040	31-029302-00	JC907	31-029705-00	JH5071
31-027779-00	JE5029	31-028698-00	JD5086	31-029303-00	JC877	31-029706-00	JC241
31-027781-00	JH5058	31-028701-00	JA5077	31-029304-00	JC852	31-029710-00(5)	JD5279(1)
31-027798-00	JJ614	31-028703-00	JJ556	31-029306-00	JD563	31-029711-00(1)	KK5522(5)
31-027824-00	JD5225	31-028731-00	JE5035	31-029307-00	JD564	31-029717-00	JM483
31-027826-00	JD478	31-028732-00	JH5095	31-029308-00	JD5155	31-029721-00	JD5255
31-027836-20(5)	JD343(1)	31-028736-00	JH5094	31-029321-00	JD5134	31-029722-00	JD5256
31-027837-10	JD228	31-028743-00	JH5018	31-029327-00	JD5135	31-029723-00	JD5277
31-027872-00	JN314	31-028750-00	JE5025	31-029328-00	JD5136	31-029753-00	JD470
31-027878-00	JD444	31-028770-00	JD416	31-029333-00	JC950	31-029755-00	JD531
31-027880-00	JD448	31-028771-00	JN937	31-029335-00	JC909	31-029758-00	JJ588
31-027881-00	JD445	31-028772-00(1)	JD014(10)	31-029307-00	JA5035	31-029795-00	JD5280
31-027891-00	JJ138	31-028775-00	JD235	31-029408-00	JA5036	31-029796-00	JD5281
31-027902-00	JN105	31-028778-00(1)	JD224(10)	31-029412-00	JA5078	31-029797-00	JD5282
31-027904-00(5)	JD281(1)	31-028781-00	JJ535	31-029413-00	JA5079	31-029803-00	JD551
31-027908-00(5)	JD487(1)	31-028783-00	JD342	31-029414-00	JM5035	31-029804-00	JC702
31-027911-00	JH5013	31-028786-00	JD467	31-029445-00	JA5075	31-029805-00	JE189
31-027913-00(2)	JA5069(1)	31-028788-00	JJ549	31-029446-00	JA5076	31-029806-00	JJ586
31-027914-00(2)	JD5109(1)	31-028789-00	JD340	31-029457-00	JH5032	31-029809-00	JD5288
31-027917-00	JA5068	31-028790-10	JD5143	31-029458-00	JH5033	31-029810-00	JD5289
31-027918-00(5)	JD5232(1)	31-028793-00	JJ615	31-029472-00	JD538	31-029814-00	JD5291
31-027926-00(5)	JD599(1)	31-028824-00	JD604	31-029496-00	JD5206	31-029815-00	JD5292
31-027984-00	JD5269	31-028918-00	JD606	31-029502-00(5)	JE5048(1)	31-029816-00	JD5293
31-028012-00(10)	JC436(1)	31-028926-00	JF211	31-029517-00	JD554	31-029817-00	JE5036
31-028013-00	JD5915	31-028940-00	JD436	31-029522-00	KK5470	31-029822-00	JD5297
31-028031-10	KK5173	31-028942-00	JJ568	31-029542-00	KK5459	31-029825-00	JD5298
31-028132-00	JN606	31-028954-00	JN460	31-029553-00	KA5020	31-029841-00	JE5039
31-028219-00	JN368	31-029026-00	JM5027	31-029575-00	JH5057	31-029842-00(5)	KK5551(1)
31-028373-00	JE5076	31-029032-00(2)	JD5164(1)	31-029576-00	JH5053	31-029845-00	KA5025
31-028377-00(5)	JD468(1)	31-029039-00(10)	JD5196(1)	31-029578-10	JE5037	31-029889-00	JD5243
31-028378-00	JD266	31-029040-00(10)	JD5197(1)	31-029592-00	JH5051	31-029890-00	JD5160
31-028385-00	JJ617	31-029043-00	JH5023	31-029601-00	JA5039	31-029900-00	JA5006
31-028386-00	JJ616	31-029088-00	JD5916	31-029603-00	JD5219	31-029901-00	JD5318
31-028392-00	JD265	31-029096-00	JE5012	31-029607-00	JH5046	31-029909-00	JD5329
31-028399-00	JR5046	31-029108-00	JH5049	31-029608-00	KA5021	31-029910-00	JD5330
31-028402-00	JH5011	31-029119-00(1)	JD5270(5)	31-029616-00	JD066	31-029911-00	JD5331
31-028409-00(10)	JD611(1)	31-029124-00	JD5183	31-029617-00	JD065	31-029912-00	JD5332
31-028417-00(5)	JC759(2)	31-029129-00	JR5022	31-029625-00	JD5428	31-029913-00	JD5333
31-028425-00	JD5144	31-029168-00	JR5030	31-029626-00	JP068	31-029914-00	JD5334
31-028430-00	JD264	31-029169-00	JH5036	31-029627-00	JH5060	31-029916-00	JD5336
31-028435-00(5)	JE5021(1)	31-029170-00(5)	JE5024(1)	31-029635-00	JM5028	31-029921-00	JD5337
31-028463-00	JD5229	31-029175-00	JH5037	31-029636-00	JM5162	31-029922-00	JD5338
31-028483-00	JN973	31-029177-00(5)	JE5017(1)	31-029639-00	KK5500	31-029923-00	KK5597
31-028554-00(5)	JD5235(1)	31-029178-00	JD5223	31-029643-00	JD5794	31-029924-00	KK5598
31-028558-00(5)	JD272(1)	31-029203-00	JD5147	31-029644-00	JD5774	31-029925-00(10)	KD931(1)
31-028581-00(5)	JD226(1)	31-029204-00	JD5148	31-029645-00	JH5062	31-029933-00	KK5599
31-028588-00	JN813	31-029207-00	JD5149	31-029655-00	JE5034	31-029936-00	KA5032
31-028589-00	JN814	31-029227-00	JD5151	31-029671-00	JD5278	31-029937-00(10)	KA5033(1)
31-028590-00	JD5233	31-029228-00	JD545	31-029678-00	JH5070	31-029942-00	JD5347
31-028595-00(2)	JC991(1)	31-029251-00	KD5001	31-029693-00	JD471	31-029943-00	JH5078
31-028597-00	JA5038	31-029265-00	JH5082	31-029694-00	KK5506	31-029944-00	JH5079
31-028598-00	JA5044	31-029296-00	JP065	31-029695-00	KK5507	31-029945-00	JH5080
31-028599-00(5)	JA5037(1)	31-029297-00	JN963	31-029697-00	JE5032	31-029948-00(10)	JD5350(1)

GOETZE	Payen	GOETZE	Payen	GOETZE	Payen	GOETZE	Payen
31-029949-00(10)	KA5034(1)	32-207595-00(1)	KA547(10)	50-026630-00	JM5113	50-028055-00	JN752
31-029950-00	KK5608	32-207670-00(1)	LT023(10)	50-026631-10	JM5115	50-028056-00	JN775
31-029958-00	JA5008	32-207705-00(1)	KD929(10)	50-026632-00	JN732	50-028057-00	JN853
31-029959-00	JA5011	33-102290-10(500)	PA349(100)	50-026642-00	JR5043	50-028065-00	JN717
31-029964-00	JH5081	33-105030-10(50)	JE646(10)	50-026643-00	JJ457	50-028111-00	JN605
31-029966-00	JD5373	33-110670-00	KJ779	50-026659-00	JM5285	50-028117-00	JN649
31-029967-00	JH859	33-110870-00	KG664	50-026709-00	JN817	50-028119-00	JN755
31-029968-00	JD5375	33-111150-00	KJ269	50-026763-00	JN562	50-028138-00	JN679
31-029969-00	JD5376	33-125040-00(500)	KJ920(100)	50-026764-00	JN533	50-028147-00	JN857
31-029974-00	JD5377	33-129051-10(500)	KV122(10)	50-026765-00	JN576	50-028187-00	JN629
31-029977-00	JD5380	33-135750-00(500)	KG5313(25)	50-026766-00	JN365	50-028189-00	JN655
31-029992-00(2)	JD5385(1)	40-029292-00	KM5001	50-026767-00	JN599	50-028194-00	JN771
31-029993-00(6)	JD5386(1)	50-022354-10(50)	HR632(8)	50-026768-00	JN496	50-028196-00	JN865
31-029997-00	JD5398	50-022425-10(50)	HR633(6)	50-026769-00	JN403	50-028198-00	JN715
31-029998-00	JD5399	50-022824-00	JM850	50-026772-00	JN432	50-028201-00	JN713
31-030002-00	JD5400	50-023445-20	JN273	50-026774-00	JN840	50-028217-00	JN656
31-030004-00	JD5401	50-023671-00	JN596	50-026784-00	JN664	50-028220-00	JN610
31-030008-00	JD5402	50-024185-00	JN335	50-026788-00	JN598	50-028221-00	JN611
31-030009-00	KK5643	50-024209-00(100)	HR291(4)	50-026853-00	JN658	50-028227-00	JN427
31-030016-00	JE5044	50-024272-00	JN462	50-026864-00	JN438	50-028280-00	JN564
31-030022-00	JR5029	50-024586-00	JN245	50-027192-10(10)	JN929(1)	50-028281-00	JM086
31-030023-00	JM5259	50-024771-00	JN292	50-027231-10	KK5520	50-028282-00	JN647
31-030027-00	JD5413	50-024962-00	JJ334	50-027319-00	JN928	50-028283-00	JN829
31-030033-00	KK5646	50-025075-10	KK5679	50-027322-00	PB248	50-028284-00	JN838
31-030116-00	JH5119	50-025202-00	JN544	50-027355-10	JM5114	50-028288-00	JN654
31-030118-00	JD5737	50-025204-10	JN547	50-027374-00	JN803	50-028297-00	JN830
31-030122-00	JH5096	50-025268-00	PB172	50-027378-00	JN809	50-028298-00	JN416
31-030176-00	JD5797	50-025333-00(200)	KA847(10)	50-027392-00	JJ508	50-028301-00	JN739
31-030196-00	JH5103	50-025409-10	JJ348	50-027393-00	JN921	50-028304-00	JN743
31-030222-00	JM7030	50-025627-00(1)	LS856(5)	50-027454-00	JN804	50-028308-00	JN724
31-030230-00(5)	JD5810(1)	50-025628-00(1)	LS857(10)	50-027500-00	JJ609	50-028309-00	JN837
31-030232-00(40)	JD5812(1)	50-025667-00	JJ458	50-027577-00	JN936	50-028315-00	JN597
31-030257-00	JD5821	50-025723-00	JN513	50-027601-00	JN994	50-028320-00	JN634
31-030261-00	JD5827	50-025919-00	JM2052	50-027665-00	JJ575	50-028361-00	JM023
31-030265-00	JD5829	50-026034-10	JN851	50-027678-00	JN969	50-028395-10	JR5031
31-030302-00	KA5038	50-026035-00	JN852	50-027683-00	JP016	50-028396-00	JR5045
31-030303-00	JR5038	50-026037-00	JN594	50-027696-00	JM5094	50-028405-00	JJ612
31-030309-00	JD5859	50-026094-00	JN667	50-027697-00	JM5095	50-028423-00	JN950
31-030310-00	JD5860	50-026098-00	JN694	50-027776-00	JN777	50-028438-00	JJ463
31-030311-00	JD5861	50-026100-00	JN585	50-027793-00	JP078	50-028450-00	JJ531
31-030312-00	JD5862	50-026131-00	JJ385	50-027806-10	JJ611	50-028471-00	JH5116
31-030313-00	KB5047	50-026180-00	JN396	50-027808-00	JJ576	50-028690-00	JD5204
31-030338-00	JD5865	50-026219-00	JN317	50-027842-00	JJ574	50-028725-00	JM5172
31-030339-00	JE5059	50-026245-00	LV943	50-027851-00	JJ573	50-028735-00	JM5075
31-030343-00	JD5867	50-026305-00	JN248	50-027852-00	JJ572	50-028751-00	JD5230
31-030346-00	JD5868	50-026336-10	JM950	50-027873-00	JN322	50-028757-00	JP041
31-030358-00	JD5869	50-026440-00	JR5040	50-027879-00(5)	JP018(1)	50-028759-00	JP043
31-030359-00	JD5870	50-026448-10	JN816	50-027927-00	JP075	50-028763-00	JP044
31-030360-00	JE5067	50-026449-00	JJ456	50-027954-00	JR5044	50-028773-00	JN810
31-030361-00	JE5068	50-026493-00	JH5019	50-027979-00	JD5203	50-028774-00	JN811
31-030367-00	JD5903	50-026499-00	JN923	50-027980-00	JD5202	50-028776-00	JN940
32-202195-10(1)	JE696(10)	50-026541-00	JP032	50-027982-00	JP008	50-028780-00	JN934
32-202265-10	JE126	50-026547-10	JR5041	50-027983-00	JP009	50-028784-00	JN972
32-206582-10(4)	JD236(1)	50-026548-10	JR5042	50-028038-00(25)	JD5226(1)	50-028785-00	JP019
32-206600-10(1)	JC365(4)	50-026603-00	JN815	50-028048-00	JN628	50-028787-00	JN933
32-206605-00	JD5917	50-026610-00	JJ455	50-028050-00	JN692	50-028817-00	JH5059

INTERCHANGE GOETZE → PAYEN













Vergleichsliste Goetze → Payen • Références croisées Goetze → Payen
Intercambio entre Goetze y Payen

GOETZE	Payen	GOETZE	Payen	GOETZE	Payen	GOETZE	Payen
50-028825-00	JJ610	50-029699-00	JD5290	50-304817-00	NA5263	50-306562-50	NA5064
50-028913-00	JP076	50-029714-00	JM5000	50-305082-00	PB177	50-306573-00	NA576
50-028922-00	JP045	50-029831-00	JM5176	50-305115-10	NA5181	50-306595-70	NB967
50-028939-00	JP006	50-029843-00	JM5181	50-305172-00	NB964	50-306622-00	NA5132
50-028953-00	JJ484	50-029871-00	JM5184	50-305260-00	KJ502	50-306632-50	NB929
50-029050-00	KK5685	50-029872-00	JD5311	50-305272-00	NB628	50-306644-50	NB959
50-029051-00	KK5686	50-029873-00(4)	JD5312(1)	50-305276-00	NA581	50-306661-50	NB980
50-029060-00	JD5156	50-029874-00	JD5313	50-305445-50	NB972	50-306664-50	NB694
50-029063-00	JH5050	50-029880-00(1)	JD5314(4)	50-305604-00	NA5264	50-306695-50	NB432
50-029071-00(40)	JD5228(4)	50-029881-00	JM5131	50-305655-00	NA5039	50-306704-00	NB697
50-029080-00	KK5484	50-029883-00	JM5270	50-305667-70	NF843	50-306757-00	NB575
50-029087-00	JM5092	50-029884-00(4)	JD5315(1)	50-305668-50	NA5265	50-306773-50	NB825
50-029152-00(2)	JD5108(1)	50-029888-00	JM5073	50-305690-50	NA5016	50-306799-50	NA5268
50-029153-00(2)	JD5107(1)	50-029895-00	JM5072	50-305705-60	NB618	50-306802-50(50)	HR661(8)
50-029167-00	JM5048	50-029899-00	JA5005	50-305717-00	NA5066	50-306831-50	NC044
50-029176-00	JM5085	50-029907-00	JM5197	50-305766-50(35)	NB734(1)	50-306841-50	NB984
50-029180-00	JM5016	50-029908-00	JM5198	50-305859-70	NB946	50-307027-70	NB928
50-029185-00	JM5121	50-029918-00	JM5201	50-305860-50	NF833	50-307047-70	NF823
50-029186-00	JD5117	50-029919-00	JM5202	50-305900-50	PA565	50-307063-50	NB644
50-029202-00	JM5059	50-029920-00	JH5077	50-305908-10	PA543	50-307065-70	NA5269
50-029232-00	JM5071	50-029935-00	JM5204	50-305909-00(100)	HR641(4)	50-307078-70	NB951
50-029271-00	JH5022	50-029939-00	JD5340	50-305910-50	NB973	50-307079-70	NB954
50-029293-00	JJ404	50-029940-00(4)	JD5341(1)	50-305912-50(100)	HR659(8)	50-307080-70	NB947
50-029294-00	JH5016	50-029960-00	JM5003	50-305913-50	NB971	50-307081-70	NB956
50-029295-00	JN736	50-029975-00(4)	JD5378(1)	50-305914-50	NA5266	50-307086-70	NF886
50-029305-00	JD311	50-029976-00(4)	JD5379(1)	50-305940-50	NB785	50-307096-70	NF853
50-029320-00	JM5063	50-029982-00	JM5234	50-305941-50	NB786	50-307111-70	NP067
50-029331-00	JM5045	50-029985-00	JM5235	50-305948-00	NF334	50-307160-70	NA5171
50-029384-00	JM5097	50-029990-00	JM5236	50-305961-70	NB934	50-307171-70	NB847
50-029385-00	JM5098	50-029991-00	JM5237	50-305984-00	NB977	50-307219-70	NB564
50-029386-00	KK5452	50-030011-00	KA5035	50-305985-50	NB935	50-307253-70	NA5164
50-029442-00	JM5034	50-030025-00	JD5411	50-306067-50	NB716	50-307265-70	NF883
50-029443-00	JM5074	50-030026-00	JD5412	50-306091-50	NB431	50-307266-70	NF885
50-029444-00	JH5014	50-030046-00	JH5117	50-306122-50(100)	KG854(80)	50-307281-70	NB567
50-029447-00	JM5037	50-030085-00	JM5002	50-306142-00	NC065	50-307318-70	LK5004
50-029456-00	JM5076	50-030203-00	JM7028	50-306222-50	NF637	50-307352-70	NA5190
50-029485-00	JH5008	50-030221-00	JM7029	50-306223-50	NB799	50-319010-00	NB884
50-029489-00	JM5119	50-030231-00(5)	JD5811(1)	50-306251-00	NF648	50-319023-10	NA869
50-029547-00	JM5103	50-030259-00	JD5823	50-306260-50	NB469	50-319060-00	NA784
50-029577-00	JM5158	50-030260-00	JD5826	50-306261-50	NB701	50-319087-00	NB690
50-029581-00	JM5154	50-030264-00	JM7034	50-306307-00	NB978	50-319112-00	NF817
50-029582-00	JM5153	50-030266-00	JD5830	50-306350-50	NB814	50-319113-00	NF870
50-029584-00	JD5299	50-030267-00	JM7035	50-306357-50	NB979	50-319116-00	PA588
50-029586-00	JH5061	50-030271-00	JM5141	50-306399-00	NF746	50-319117-00	NB619
50-029587-00	JM5155	50-030340-00	JD5866	50-306413-50	NB788	50-319161-00	NC006
50-029604-00	JD5220	50-030368-00	JD5904	50-306429-00	NF387	50-319170-00	NB953
50-029605-00	JM5104	50-300469-00	NJ255	50-306431-60	NB939	50-319183-00	NF850
50-029609-00	JD5227	50-300693-10	NA585	50-306445-50	NC015	50-319184-00	NB633
50-029632-00	JH5015	50-300902-20	NB695	50-306445-50	NA5267	50-319189-00	NA5177
50-029633-00	JM5159	50-301156-00	NF200	50-306487-00	NB807	50-319192-00	NB974
50-029656-00	JM5263	50-301474-00	NF369	50-306526-50	NB939	50-319221-00	NJ011
50-029661-00(1)	JD5740(10)	50-301756-10	NB450	50-306551-50	NB700	50-319223-00(10)	NF036(1)
50-029666-00	JM5163	50-303185-50	NA5001	50-306552-00	NB806	50-319235-10	NA5270
50-029667-00	JM5164	50-303186-00	NP068	50-306553-50	NB792	50-319239-00	NF835
50-029668-00	JM5165	50-303718-00	NA5262	50-306557-50	NB975	50-319241-00	NF834
50-029692-00	JP020	50-304240-00	NJ634	50-306560-50	PA425	50-319258-00	NF603













GOETZE	Payen	GOETZE	Payen	GOETZE	Payen	GOETZE	Payen
50-319261-00	NF604	50-319437-00	NA5168	50-323783-00	KV065		
50-319262-00	NF316	50-319440-00	NF812	50-323948-00	NA5274		
50-319265-00(8)	PA658(100)	50-319441-00	LK5005	50-324120-00	SR402		
50-319266-00	NJ449	50-319442-00	NA5157	50-324191-00	LT004		
50-319268-00(10)	NK103(1)	50-319443-00(8)	PA5033(25)	50-324203-00	NA5275		
50-319273-00	NB698	50-319444-00	NA5130	50-324407-00	JN943		
50-319275-00	NF849	50-319446-00	NA5147	50-324418-00(250)	HR564(4)		
50-319285-00	NB698	50-319447-00	NA5149	50-324442-00	NA5276		
50-319310-00	NF841	50-319448-00	LK5006	50-324444-00	PB015		
50-319321-00	NA5271	50-319449-00	NA5139	50-324505-00(500)	PA229(25)		
50-319323-00	NB958	50-319450-00	NA5140	50-324560-00(500)	HR566(4)		
50-319324-00	NA5272	50-319453-00	NA5156	50-324824-00	KJ760		
50-319334-00	NA5273	50-319454-00	PA928	50-350050-00	SR452		
50-319343-00	NF634	50-319455-00	LK5007	50-350052-00	NA5277		
50-319352-00	NA5138	50-319456-00	LK5001	50-350092-00	NA5278		
50-319354-00	NA5017	50-319457-00	NA5031	50-350172-00	NA5279		
50-319355-00(10)	NF761(1)	50-319459-00	NA5175	50-350182-00	NA5280		
50-319360-00	NA5120	50-319464-00	NB720	50-350226-00	JD612		
50-319361-00	NA5121	50-319466-00	NA5013	50-350416-00	LA5204		
50-319362-00(100)	HR808(8)	50-319467-00	NB849	50-350435-00(1)	KG5337(4)		
50-319363-00(100)	HR809(8)	50-319469-00	NA5174				
50-319367-00	NA5137	50-319470-00	NA5136				
50-319368-00	NC048	50-319471-00	NA5173				
50-319371-00	NB856	50-319472-00	LK5008				
50-319374-00(1000)	HR814(16)	50-319473-00	NA5036				
50-319375-00	NB855	50-319474-00	NA5035				
50-319376-00	NB854	50-319477-00	NB727				
50-319382-00	NA5099	50-319478-00	NF857				
50-319384-00	NB932	50-319480-00	NA5178				
50-319385-00	NB933	50-319481-00	NA5179				
50-319386-00	PA5025	50-319482-00	LK5009				
50-319388-00	NA5105	50-319484-00	NA5180				
50-319389-00	NA5104	50-319486-00	NA5028				
50-319391-00	NA5103	50-319487-00	NA5030				
50-319392-00	NA5108	50-319488-00	NA5053				
50-319393-00	NF887	50-319489-00	NA5185				
50-319396-00	NA5074	50-319492-00	NA5187				
50-319399-00	NB828	50-319496-00	PA5020				
50-319400-00	NB829	50-319497-00	PA5019				
50-319402-00	NB998	50-319498-00	NA5089				
50-319404-00	NA5109	50-319499-00	NA5090				
50-319405-00	NA5107	50-319500-00	NA5191				
50-319408-00	NB742	50-319501-00	NA5192				
50-319410-00	NA5045	50-319509-00	NA5201				
50-319419-00	NB774	50-319514-00	NA5209				
50-319420-00	NB843	50-319515-00	NA5069				
50-319423-00	NA5083	50-319516-00	NF846				
50-319424-00	LK5000	50-319517-00	NC086				
50-319426-00	NA5023	50-319520-00	NA5223				
50-319427-00	LK5002	50-319522-00	NA5230				
50-319429-00	NB584	50-319523-00	NB815				
50-319430-00	NA5106	50-319524-00	NA5070				
50-319432-00	NA5118	50-319526-00	NF888				
50-319433-00	NA5124	50-319527-00	NA5040				
50-319434-00	LK5003	50-319531-00	NA5238				
50-319436-00	NA5131	50-319535-00	LK5012				

CYLINDER HEADBOLTS

Zylinderkopfschrauben • Vis de culasse
Tornillo

					QTY								QTY			
HBS001	M10	1.50	135.00	10.00	10.00	A			HBS050	M11	1.50	120.00	10.00	10.00	A	✓
HBS002	M10	1.25	140.00	10.00	10.00	E			HBS051	M10	1.25	84.00	5.00	5.00	A	
HBS003	M11	1.25	140.00	10.00	10.00	A			HBS051	M10	1.25	98.00	5.00	5.00	A	
HBS005	M9	1.25	412.00	10.00	10.00	E			HBS052	M9	1.25	95.00	10.00	10.00	I	
HBS006	M10	1.50	133.00	10.00	10.00	A			HBS053	M11	1.25	140.00	10.00	10.00	F	✓
HBS007	7/16	14H	135.00	10.00	10.00	A			HBS054	M11	1.25	105.00	10.00	10.00	E	✓
HBS008	M12	1.75	92.00	18.00	18.00	A			HBS055	M10	1.25	153.00	10.00	10.00	E	✓
HBS010	M12	1.50	134.00	8.00	8.00	B			HBS056	M12	1.75	92.5.00	10.00	10.00	E	
HBS010	M12	1.50	148.00	4.00	4.00	A			HBS057	M12	1.75	87.00	16.00	16.00	E	
HBS010	M12	1.50	247.00	2.00	2.00	A			HBS058	M10	1.50	80.00	4.00	4.00	D	
HBS011	M12	1.25	119.00	12.00	12.00	I	✓		HBS058	M10	1.50	102.00	9.00	9.00	D	
HBS011	M12	1.25	160.00	10.00	10.00	I	✓		HBS058	M10	1.50	115.00	5.00	5.00	D	
HBS015	M11	1.50	97.50	8.00	8.00	A			HBS059	M10	1.50	80.00	5.00	5.00	D	
HBS015	M11	1.50	107.50	7.00	7.00	A			HBS059	M10	1.50	102.00	11.00	11.00	D	
HBS015	M11	1.50	120.00	7.00	7.00	A			HBS059	M10	1.50	115.00	6.00	6.00	D	
HBS016	M11	1.50	107.50	15.00	15.00	A			HBS060	M10	1.50	80.00	6.00	6.00	D	
HBS016	M11	1.50	120.00	7.00	7.00	A			HBS060	M10	1.50	102.00	13.00	13.00	D	
HBS017	M12	1.50	118.00	9.00	9.00	A			HBS060	M10	1.50	115.00	7.00	7.00	D	
HBS017	M12	1.50	145.00	8.00	8.00	A			HBS061	M10	1.50	102.00	14.00	14.00	D	
HBS018	M12	1.75	115.00	10.00	10.00	D	✓		HBS061	M10	1.50	115.00	4.00	4.00	D	
HBS021	M12	1.75	115.00	12.00	12.00	D	✓		HBS062	M10	1.50	102.00	17.00	17.00	D	
HBS022	M12	1.75	115.00	14.00	14.00	D	✓		HBS062	M10	1.50	115.00	5.00	5.00	D	
HBS024	M11	1.50	95.00	12.00	12.00	D	✓		HBS063	M10	1.50	102.00	20.00	20.00	D	
HBS028	M11	1.50	147.00	10.00	10.00	D	✓		HBS063	M10	1.50	115.00	6.00	6.00	D	
HBS029	M11	1.50	98.00	10.00	10.00	D	✓		HBS064	M11	1.50	137.00	16.00	16.00	D	✓
HBS031	M10	1.50	102.00	10.00	10.00	F			HBS065	M11	1.50	140.00	14.00	14.00	E	
HBS032	M11	1.50	178.00	10.00	10.00	F	✓		HBS066	M12	1.50	146.50	14.00	14.00	E	✓
HBS033	M12	1.75	136.00	10.00	10.00	F			HBS067	M10	1.50	110.00	14.00	14.00	E	
HBS035	M11	1.25	110.00	10.00	10.00	E			HBS068	M10	1.50	95.00	14.00	14.00	E	
HBS036	M12	1.50	102.00	10.00	10.00	B	✓		HBS069	M10	1.50	95.00	10.00	10.00	E	
HBS038	M11	1.50	175.00	10.00	10.00	F			HBS070	M12	1.75	157.00	10.00	10.00	A	
HBS039	M10	1.50	175.00	10.00	10.00	E			HBS071	M12	1.75	157.00	14.00	14.00	A	
HBS041	M10	1.50	150.00	14.00	14.00	E			HBS074	M11	1.25	154.00	10.00	10.00	F	✓
HBS042	M11	1.25	123.00	8.00	8.00	C			HBS075	M11	1.50	110.00	10.00	10.00	D	✓
HBS042	M11	1.25	145.00	10.00	10.00	C			HBS077	M11	1.50	85.00	7.00	7.00	D	✓
HBS043	M11	1.50	95.00	10.00	10.00	D	✓		HBS077	M11	1.50	119.00	10.00	10.00	D	✓
HBS044	M12	1.75	115.00	10.00	10.00	B			HBS077	M11	1.50	144.00	3.00	3.00	D	✓
HBS045	M12	1.75	105.00	4.00	4.00	D			HBS078	M10	1.50	143.00	10.00	10.00	F	
HBS045	M12	1.75	120.00	8.00	8.00	D			HBS082	M10	1.50	185.00	10.00	10.00	E	
HBS045	M12	1.75	145.00	6.00	6.00	D			HBS083	M11	1.50	168.00	10.00	10.00	A	
HBS046	M12	1.75	105.00	5.00	5.00	D			HBS084	M12	1.50	120.00	10.00	10.00	F	
HBS046	M12	1.75	120.00	9.00	9.00	D			HBS086	M11	1.50	179.00	10.00	10.00	A	
HBS046	M12	1.75	145.00	8.00	8.00	D			HBS087	M12	1.50	110.00	10.00	10.00	F	
HBS047	M12	1.75	120.00	10.00	10.00	D			HBS088	M12	1.50	145.00	10.00	10.00	F	





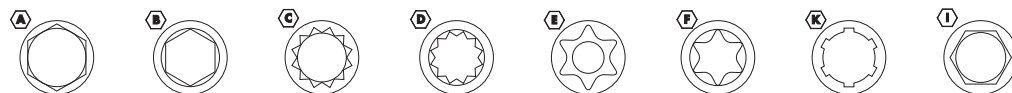









					QTY								QTY		
HBS089	M11	1.50	159.00	10.00	Ⓔ			HBS133	M10	1.25	254.00	12.00	Ⓘ		
HBS092	M10	1.25	115.00	10.00	Ⓚ			HBS136	M11	1.50	104.50	10.00	Ⓚ		
HBS093	M10	1.25	172.00	10.00	Ⓚ			HBS140	M12	1.75	115.00	16.00	Ⓚ		✓
HBS095	M12	1.25	133.00	10.00	Ⓚ			HBS146	M12	1.75	102.00	14.00	Ⓚ		
HBS097	M12	1.25	120.00	10.00	Ⓚ			HBS150	M12	1.75	102.00	10.00	Ⓚ		
HBS098	M10	1.25	116.00	5.00	Ⓒ			HBS152	M12	1.75	160.00	14.00	Ⓚ		
HBS098	M12	1.25	140.00	5.00	Ⓐ			HBS160	M13	1.50	134.00	10.00	Ⓚ		✓
HBS102	M10	1.50	98.00	5.00	Ⓔ			HBS161	M12	1.50	64.00	5.00	Ⓚ		
HBS102	M10	1.50	113.00	5.00	Ⓔ			HBS161	M12	1.50	97.50	5.00	Ⓚ		
HBS104	M10	1.50	100.00	10.00	Ⓐ			HBS163	M13	1.50	134.00	10.00	Ⓚ		
HBS105	M12	1.75	80.00	4.00	Ⓐ			HBS164	M11	1.25	105.00	16.00	Ⓔ		✓
HBS105	M12	1.75	116.00	4.00	Ⓐ			HBS171	M11	1.50	101.00	10.00	Ⓚ		
HBS105	M14	2.0	137.00	10.00	Ⓐ			HBS173	M11	1.5	133.00	1.00	Ⓚ		
HBS106	M12	1.75	80.00	5.00	Ⓐ			HBS173	M11	1.5	168.00	7.00	Ⓚ		
HBS106	M12	1.75	116.00	5.00	Ⓐ			HBS173	M11	1.5	182.00	2.00	Ⓚ		
HBS106	M14	2.0	137.00	12.00	Ⓐ			HBS174	M12	1.75	133.00	10.00	Ⓚ		
HBS107	M12	1.75	80.00	3.00	Ⓐ			HBS175	M12	1.75	77.00	3.00	Ⓐ		
HBS107	M12	1.75	116.00	3.00	Ⓐ			HBS175	M12	1.75	115.00	7.00	Ⓐ		
HBS107	M14	2.0	137.00	8.00	Ⓐ			HBS177	M12	1.50	108.00	10.00	Ⓔ		✓
HBS108	M12	1.75	79.50	4.00	Ⓚ			HBS178	M12	1.75	157.00	10.00	Ⓚ		
HBS108	M12	1.75	115.00	4.00	Ⓚ			HBS179	M12	1.75	121.50	10.00	Ⓔ		
HBS108	M14	2.0	137.00	10.00	Ⓚ			HBS180	M12	1.75	95.50	10.00	Ⓔ		
HBS109	M9	1.25	60.00	1.00	Ⓐ			HBS185	M12	1.75	157.00	12.00	Ⓚ		
HBS109	M9	1.25	95.00	9.00	Ⓚ			HBS187	M10	1.50	97.00	10.00	Ⓚ		
HBS110	M10	1.50	146.00	10.00	Ⓚ			HBS188	M11	1.50	157.00	10.00	Ⓚ		
HBS111	M11	1.50	119.00	10.00	Ⓚ			HBS189	M12	1.75	105.50	18.00	Ⓐ		
HBS112	M9	1.25	80.00	5.00	Ⓐ			HBS190	M12	1.75	112.00	14.00	Ⓚ		
HBS112	M9	1.25	100.00	5.00	Ⓐ			HBS194	M12	1.50	113.00	18.00	Ⓐ		
HBS113	M11	1.50	185.00	10.00	Ⓔ	✓		HBS195	M12	1.75	135.00	6.00	Ⓚ		
HBS114	M10	1.50	148.00	8.00	Ⓔ	✓		HBS195	M12	1.75	165.00	4.00	Ⓚ		
HBS114	M12	1.50	138.00	14.00	Ⓔ	✓		HBS197	M9	1.25	98.00	10.00	Ⓐ		
HBS115	M12	1.50	145.00	10.00	Ⓔ			HBS198	M10	1.25	93.00	10.00	Ⓚ		
HBS116	M12	1.50	243.00	10.00	Ⓐ	✓		HBS200	M10	1.25	94.50	10.00	Ⓒ		
HBS119	M11	1.50	103.00	4.00	Ⓔ	✓		HBS203	M10	1.25	90.00	5.00	Ⓒ		
HBS119	M11	1.50	185.00	5.00	Ⓔ	✓		HBS203	M10	1.25	108.00	5.00	Ⓒ		
HBS119	M11	1.50	185.00	5.00	Ⓔ			HBS209	M12	1.25	127.00	18.00	Ⓒ		
HBS119	M11	1.50	207.50	4.00	Ⓔ			HBS211	M12	1.50	113.00	10.00	Ⓒ		
HBS120	M12	1.50	118.00	10.00	Ⓔ	✓		HBS215	M10	1.25	95.00	10.00	Ⓔ		
HBS121	M12	1.50	146.50	10.00	Ⓔ	✓		HBS216	M12	1.25	104.00	14.00	Ⓒ		
HBS125	M12	1.50	150.50	10.00	Ⓔ			HBS216	M12	1.25	124.00	4.00	Ⓒ		
HBS127	M12	1.50	178.00	16.00	Ⓐ			HBS216	M8	1.25	90.00	2.00	Ⓐ		
HBS130	M10	1.25	163.00	10.00	Ⓚ			HBS217	M10	1.25	95.00	16.00	Ⓔ		
HBS131	M10	1.25	100.00	10.00	Ⓚ			HBS218	M11	1.25	190.00	12.00	Ⓒ		✓
HBS132	M10	1.25	254.00	10.00	Ⓚ			HBS222			7/16	65.00	14.00	Ⓐ	















CYLINDER HEAD BOLTS

Zylinderkopfschrauben • Vis de culasse
Tornillo

					QTY								QTY		
HBS222		7/16	97.00	6.00	6.00	A			HBS279	M11	1.50	154.00	6.00	A	✓
HBS223	M10	1.50	117.00	4.00	4.00	A			HBS280	M11	1.50	145.00	10.00	A	✓
HBS223	M12	1.50	100.00	4.00	4.00	A			HBS281	M12	1.50	162.00	9.00	C	✓
HBS223	M12	1.50	140.00	10.00	10.00	A			HBS281	M12	1.50	198.00	1.00	C	✓
HBS224	M10	1.50	117.00	4.00	4.00	A			HBS282	M11	1.50	230.00	10.00	E	✓
HBS224	M12	1.50	100.00	4.00	4.00	A			HBS283	M9	1.25	122.00	10.00	E	
HBS224	M12	1.50	125.00	10.00	10.00	A			HBS284	M12	1.50	163.00	9.00	C	✓
HBS227	M12	1.25	218.00	10.00	10.00	K			HBS284	M12	1.50	198.00	1.00	C	✓
HBS229	M11	1.50	97.00	1.00	1.00	G			HBS285	M10	1.25	166.00	10.00	A	
HBS229	M11	1.50	97.50	7.00	7.00	A			HBS286	M11	1.50	116.00	16.00	A	
HBS229	M11	1.50	107.50	7.00	7.00	A			HBS286	M11	1.50	117.00	3.00	A	
HBS229	M11	1.50	120.00	7.00	7.00	A			HBS287	M11	1.50	121.00	18.00	A	
HBS241	M9	1.25	103.00	10.00	10.00	E			HBS288	M10	1.25	100.00	8.00	C	
HBS243	M12	1.75	137.00	2.00	2.00	F			HBS288	M12	1.50	113.00	10.00	C	
HBS243	M12	1.75	177.00	8.00	8.00	F			HBS289	M12	1.50	113.00	10.00	C	
HBS244	M12	1.50	111.00	10.00	10.00	E	✓		HBS291	M12	1.75	185.00	10.00	E	
HBS245	M12	1.50	125.00	10.00	10.00	E	✓		HBS292	M12	1.75	102.00	10.00	E	
HBS246	M10	1.50	120.00	10.00	10.00	K	✓		HBS293	M12	1.75	102.00	12.00	E	
HBS247	M9	1.25	87.00	10.00	10.00	K			HBS294	M12	1.75	102.00	14.00	E	
HBS249	M9	1.25	138.00	10.00	10.00	D			HBS295	M12	1.25	104.00	18.00	B	
HBS251	M11	1.50	133.00	4.00	4.00	E	✓		HBS296	M10	1.5	159.00	10.00	A	
HBS251	M14	1.50	193.00	6.00	6.00	E	✓		HBS296	M8	1.25	120.00	8.00	A	
HBS252	M8	1.25	119.00	12.00	12.00	E			HBS297	M9	1.25	56.00	1.00	I	
HBS253	M8	1.25	119.00	10.00	10.00	E			HBS297	M9	1.25	91.00	9.00	I	
HBS254	M10	1.50	122.00	10.00	10.00	E			HBS298	M12	1.50	235.00	10.00	E	✓
HBS255	M12	1.25	90.00	8.00	8.00	I	✓		HBS299	M11	1.50	125.00	10.00	E	
HBS255	M12	1.25	160.00	14.00	14.00	I	✓		HBS300	M12	1.75	166.00	10.00	D	
HBS257	M12	1.25	218.00	12.00	12.00	K			HBS301	M10	1.50	117.00	10.00	E	
HBS259	M11	1.50	144.50	10.00	10.00	E	✓		HBS302	M12	1.50	204.00	10.00	E	✓
HBS260	M11	1.50	168.00	10.00	10.00	E			HBS303	M12	1.75	162.00	12.00	I	
HBS261	M12	1.50	126.00	10.00	10.00	E			HBS305	M11	1.50	162.00	10.00	A	
HBS262	M10	1.25	220.00	10.00	10.00	K			HBS306	M9	1.25	84.00	5.00	C	
HBS263	M12	1.50	140.00	10.00	10.00	D	✓		HBS306	M9	1.25	98.00	5.00	C	
HBS264	M12	1.75	166.00	8.00	8.00	D			HBS307	M12	1.25	104.00	10.00	B	
HBS265	M12	1.50	155.00	16.00	16.00	D			HBS308	M10	1.25	99.00	8.00	B	
HBS268	M10	1.50	120.00	10.00	10.00	K			HBS308	M12	1.25	151.00	2.00	B	
HBS269	M11	1.50	141.50	12.00	12.00	D	✓		HBS309	M11	1.50	128.00	10.00	E	
HBS270	M11	1.50	133.00	16.00	16.00	K			HBS310	M12	1.50	117.00	10.00	E	
HBS272	M10	1.50	147.00	16.00	16.00	E	✓		HBS311	M12	1.75	115.00	8.00	D	✓
HBS273	M10	1.50	174.00	8.00	8.00	E	✓		HBS312	M9	1.25	84.00	10.00	D	
HBS273	M12	1.50	163.00	14.00	14.00	E	✓		HBS313	M9	1.50	143.00	10.00	D	
HBS277	M12	1.50	148.00	10.00	10.00	F			HBS314	M11	1.25	160.00	8.00	C	
HBS278	M12	1.50	110.00	10.00	10.00	E			HBS314	M12	1.25	104.00	10.00	C	
HBS279	M11	1.50	109.00	4.00	4.00	A	✓		HBS315	M12	1.25	106.00	4.00	C	



					QTY								QTY		
HBS315	M12	1.25	126.00	14.00	14.00	C			HBS413	M10	1.50	110.00	14.00	E	
HBS316	M9	1.25	97.00	10.00	10.00	D			HBS415	M10	1.50	140.00	10.00	F	
HBS349	M9	1.25	145.00	8.00	8.00	E			HBS416	M11	1.50	163.00	10.00	I	
HBS353	M10	1.25	119.00	10.00	10.00	K			HBS417	M12	1.50	88.00	14.00	F	✓
HBS354	M11	1.25	97.00	10.00	10.00	C	✓		HBS418	M11	1.25	97.00	10.00	C	✓
HBS358	M11	1.50	158.00	10.00	10.00	F			HBS419	M11	1.50	110.00	18.00	A	✓
HBS358	M8	1.00	45.00	2.00	2.00	F			HBS420	M11	1.50	100.00	10.00	B	
HBS359	M11	1.50	150.00	10.00	10.00	E			HBS421	M11	1.25	118.00	10.00	C	✓
HBS360	M11	1.50	142.00	10.00	10.00	D			HBS422	M10	1.50	92.00	10.00	B	
HBS361	M12	1.50	159.00	16.00	16.00	D			HBS423	M9	1.25	200.00	16.00	E	
HBS362	M9	1.25	162.00	10.00	10.00	D			HBS425	M11	1.25	105.00	10.00	C	
HBS363	M10	1.50	122(128)	10.00	10.00	F			HBS426	M12	1.75	162.00	14.00	I	
HBS364	M12	1.75	149(151)	10.00	10.00	D			HBS431	M12	1.50	137.00	10.00	E	
HBS368	M12	1.50	131.50	10.00	10.00	E			HBS432	M10	1.50	110.00	10.00	A	
HBS369	M10	1.25	145.50	10.00	10.00	F			HBS433	M12	1.50	113.00	26.00	A	
HBS370	M12	1.25	225.00	10.00	10.00	K			HBS434	M12	1.25	152.00	18.00	C	
HBS371	M12	1.25	225.00	12.00	12.00	K			HBS436	M11	1.50	95.00	2.00	C	
HBS372	M12	1.50	121.00	10.00	10.00	E			HBS436	M11	1.50	115.00	8.00	C	
HBS373	M12	1.50	131.00	10.00	10.00	E			HBS439	M11	1.50	170.00	10.00	A	
HBS374	M11	1.25	109.00	18.00	18.00	B	✓		HBS439	M8	1.25	28.00	4.00	A	
HBS377	M10	1.25	97.00	8.00	8.00	I	✓		HBS440	M10	1.25	100.00	10.00	A	
HBS378	M10	1.25	106.50	10.00	10.00	B	✓		HBS441	M11	1.50	162.00	10.00	D	✓
HBS379	M12	1.25	92.00	8.00	8.00	C			HBS443	M10	1.50	116.00	9.00	C	✓
HBS379	M12	1.25	131.00	10.00	10.00	C			HBS443	M10	1.50	127.00	4.00	C	✓
HBS381	M12	1.50	183.00	10.00	10.00	C	✓		HBS445	M10	1.50	110.00	10.00	A	
HBS382	M12	1.50	183.00	10.00	10.00	C	✓		HBS446	M11	1.50	147.75	16.00	D	✓
HBS385	M10	1.50	147.00	10.00	10.00	D	✓		HBS447	M11	1.50	116.00	10.00	D	
HBS386	M12	1.25	163.00	10.00	10.00	A			HBS447	M6	1.00	40.00	1.00	D	
HBS387	M10	1.25	107.00	10.00	10.00	B	✓		HBS450	M11	1.25	91.00	14.00	D	✓
HBS391	M11	1.50	160.00	4.00	4.00	A	✓		HBS452	M10	1.25	120.00	10.00	D	
HBS391	M11	1.50	205.00	6.00	6.00	A	✓		HBS454	M10	1.25	95.00	10.00	B	
HBS392	M10	1.50	150.00	16.00	16.00	D	✓		HBS455	M12	1.25	95.00	10.00	C	
HBS394	M11	1.25	96.00	16.00	16.00	C	✓		HBS457	M10	1.50	180.00	10.00	E	
HBS397	M11	1.25	115.00	16.00	16.00	A			HBS458	M12	1.75	115.00	10.00	E	
HBS402	M12	1.25	102.00	16.00	16.00	D			HBS459	M10	1.50	165.00	10.00	E	
HBS404	M11	1.25	120.00	8.00	8.00	C			HBS460	M10	1.50	154.00	8.00	F	
HBS404	M11	1.25	120.00	8.00	8.00	C			HBS461	M11	1.50	85.00	6.00	D	
HBS405	M11	1.25	169.00	12.00	12.00	D	✓		HBS461	M11	1.50	119.00	9.00	D	
HBS406	M11	1.25	136.00	10.00	10.00	D			HBS461	M11	1.50	144.00	3.00	D	
HBS407	M10	1.50	91.00	8.00	8.00	D	✓		HBS463	M11	1.50	141.00	8.00	F	
HBS408	M10	1.50	100.00	8.00	8.00	D	✓		HBS465	M12	1.50	220.00	10.00	K	
HBS409	M10	1.50	70.00	4.00	4.00	D	✓		HBS466	M10	1.50	111.00	13.00	D	
HBS409	M10	1.50	85.00	5.00	5.00	D	✓		HBS466	M10	1.50	150(141)	7.00	D	
HBS409	M10	1.50	100.00	1.00	1.00	D	✓		HBS467	M10	1.50	170.00	6.00	E	

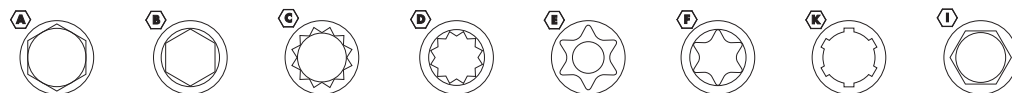

JOINTS CUIVRE - COPPER WASHERS

Jointes cuivre : Cuivre recuit pour 1 dureté maximale de 50 HB - Résistance thermique : 600°C Environ

JO.	CUIVRE	ANC. REF.	REF. PAYEN	JO.	CUIVRE	ANC. REF.	REF. PAYEN	JO.	CUIVRE	ANC. REF.	REF. PAYEN
4	4 X 8 X 1	323505	KG5234		10,2 X 13,5 X 1,5	321777	KG5185		14 X 21 X 0,8	303808	KG5099
5	5 X 8,5 X 0,9	321184	KG5171		10,2 X 13,9 X 1	322335	KG5219		14,1 X 18 X 1	322360	KG5227
	5 X 10 X 1,5	320386	KG5159		10,2 X 15 X 1	305332	KG5105		14,1 X 18 X 1,5	322076	KG5218
	5,2 X 8 X 1	305231	KG5101		10,2 X 17 X 1	302465	KG5092		14,1 X 20,5 X 1,5	311823	KG5147
6	6 X 9,4 X 0,8	321924	KG5198		10,2 X 17 X 1,5	311462	KG5139		14,2 X 19,5 X 1	320849	KG5165
	6 X 10 X 0,5	323504	KG5233		10,2 X 17 X 2	323915	KG5239		14,2 X 20 X 1	305358	KG5110
	6 X 11 X 2,5	322347	KG5223		10,2 X 20 X 1	310308	KG5130		14,2 X 21,8 X 2	309012	KG5122
	6,2 X 10 X 1	306285	KG5117		10,3 X 15,8 X 1	305372	KG5112		14,2 X 22 X 1	322393	KG5232
	6,5 X 12 X 1	306225	KG5114		10,5 X 16 X 2,5	323773	KG5237		14,3 X 18 X 1,5	311725	KG5144
7	7,2 X 11 X 1	305317	KG5103		10,5 X 18 X 2	300004	KG5077		14,3 X 19 X 1	302291	KG5089
8	8 X 13 X 1,5	321180	KG5170		10,8 X 19,5 X 1	300002	KG5075		14,3 X 19 X 1,5	311694	PA335
	8 X 16 X 2	322026	KG5214	11	11 X 16 X 1,5	320528	KG5160		14,4 X 19 X 2	308783	KG5121
	8,1 X 11,2 X 1	323794	KG5238		11 X 20 X 1,5	300025	KG5083		14,5 X 20 X 1,5	311136	PA401
	8,1 X 11,5 X 1	311853	KG5149		11 X 20 X 2	300042	PA413		14,5 X 20 X 2	322355	KJ920
	8,2 X 12 X 1	302830	KG5094		11,2 X 16 X 1	310309	KG5131		14,5 X 21 X 1,5	304687	KG5100
	8,2 X 12 X 1,5	322337	KG5221		11,2 X 20 X 1	300001	KG5074		14,5 X 21 X 1,8	323758	KG5235
	8,2 X 14 X 1	305356	KG5108	12	12 X 15,5 X 1	321093	KG5168		14,5 X 21,3 X 1,5	322336	KG5220
	8,2 X 14 X 1,5	300003	KG5076		12 X 16 X 1	321968	KG5202		14,5 X 21,3 X 1,8	300035	KG5085
	8,2 X 15 X 2	321394	KG5177		12 X 20 X 1,5	322008	KG5209		14,5 X 21,4 X 2,3	312620	KG5151
	8,3 X 16 X 1	306235	KG5116		12 X 22 X 1	321825	KG5190		14,7 X 21,4 X 1,95	300037	KG5087
	8,5 X 17 X 1	305243	KG5102		12,1 X 15,7 X 1	309806	KG5124		14,8 X 22 X 1,5	311458	KG5138
9	9,2 X 14 X 1,2	321354	KG5173		12,2 X 15,9 X 1,5	320693	KG5162	15	15 X 20 X 1	321785	KG5187
	9,2 X 20 X 1	306234	KG5115		12,2 X 17 X 2	300012	KG5081		15 X 20 X 1,5	311483	KG5143
	9,5 X 16 X 2,5	323759	KG5236		12,2 X 18 X 1	302844	KG5095		15 X 24 X 1	306308	KG5118
	9,5 X 17,5 X 1,5	321473	KG5181		12,2 X 21,5 X 1	305357	KG5109		15,3 X 21 X 1,2	310289	PA348
	9,5 X 18 X 1	321961	KG5201		12,5 X 16,8 X 1	321989	KG5206		15,5 X 20 X 2	321915	KG5197
	9,5 X 18 X 2	321441	KG5179		12,5 X 18 X 1	322012	SUPP,		15,6 X 21,2 X 2,2	320694	PA345
	9,5 X 20 X 1	321472	KG5180		12,5 X 18 X 1,5	311581	PA400	16	16 X 20 X 1,5	320107	KG5155
	9,5 X 20 X 1,5	300005	KG5078		12,5 X 18 X 2	311756	KG5145		16 X 22,5 X 3	321983	KG5205
	9,7 X 14,2 X 1,8	311858	KG5150		12,5 X 19 X 1,5	302918	KG5097		16 X 23,6 X 1,5	321998	KG5207
	9,8 X 21 X 2	312768	KG5153		12,5 X 20 X 0,8	302466	KG5093		16 X 24 X 1	321914	KG5196
10	10 X 14 X 0,8	321973	KG5204		12,5 X 20 X 1	321574	KG5183		16,2 X 19 X 1,5	322023	KG5212
	10 X 15 X 3	300019	SUPP,		12,7 X 16 X 2	300014	PA347		16,2 X 20 X 0,5	321967	KJ749
	10 X 15 X 3,5	300020	KG5082		12,7 X 17 X 1,5	320092	KG5154		16,2 X 20 X 1	302317	KG5091
	10 X 15,7 X 2,5	321305	KG5172		12,8 X 17,1 X 1,5	321806	KG5189		16,2 X 21,5 X 1	305320	KG5104
	10 X 16 X 1,5	311794	KG5146	13	13 X 18 X 1	320848	KG5164		16,2 X 21,5 X 2	322348	KG5224
	10 X 19,5 X 2	321076	KG5167		13 X 19 X 1,5	321940	KG5199		16,2 X 22 X 1,5	320669	KG5161
	10,1 X 14,5 X 1	320847	KG5163		13 X 20,4 X 1,5	321972	KG5203		16,2 X 22,9 X 1,5	321828	KG5191
	10,1 X 18 X 1	302290	PA333		13,1 X 19,8 X 1	310340	KG5132		16,3 X 22 X 1	310141	PA217
	10,0 X 18,8 X 2	321365	KG5174		13,2 X 18 X 1,5	322363	KG5228		16,5 X 20,5 X 2	311138	KG5136
	10,0 X 20,8 X 2	320347	KG5157		13,7 X 18,5 X 1	310861	KG5134		16,5 X 21 X 2,5	322015	KG5211
	10,2 X 13 X 1	321390	KG5175	14	14 X 18 X 2	305638	KG5113		16,5 X 23 X 1	310066	KG5127

JOINTS CUIVRE - COPPER WASHERS

JO.	CUIVRE	ANC. REF.	REF. PAYEN	JO.	CUIVRE	ANC. REF.	REF. PAYEN
	16,5 X 24 X 1,5	306352	KG5119		24,4 X 32 X 1,5	311354	KG5137
	16,85 X 20 X 1,5	300048	KG5088		24,5 X 32 X 2	321953	KG5200
17	17 X 21 X 1	302910	KG5096	25	25,4 X 30 X 1,5	310067	KJ646
	17 X 22 X 1,5	321779	KG5186	26	26 X 30 X 1,5	321893	KG5193
18	18,2 X 22 X 1	322394	KJ645		26,1 X 32 X 1	305359	KG5111
	18,2 X 22 X 1,5	322375	KG5231		26,3 X 33 X 3	322028	KG5215
	18,2 X 23 X 1	300008	KG5080	27	27 X 34 X 2	300034	KG5084
	18,2 X 23 X 1,5	321573	KG5182		27,2 X 32 X 1,5	300043	PA416
	18,2 X 26 X 1,5	321391	KG5176	28	28,2 X 35 X 1,5	311479	KG5140
	18,3 X 24 X 1,5	320383	KG5158	30	30,4 X 38 X 1	310162	KG5129
	18,3 X 24 X 2	320871	PA336		30,5 X 36 X 2	306410	KG5120
	18,3 X 24,3 X 2	322001	KG5208	32	32 X 42 X 1	322357	KG5226
	18,5 X 23 X 1	302920	KG5098	36	36 X 42 X 2	310779	KG5133
	18,5 X 23 X 2	321070	KG5166		36,4 X 45 X 2	321805	KG5188
	18,5 X 24 X 1	310145	KG5128				
	18,5 X 26 X 2	310021	KG5126				
19	19,3 X 23,9 X 1,5	320117	KG5156				
20	20,1 X 26 X 1	302298	KG5090				
	20,2 X 25 X 1,5	321094	KG5169				
	20,5 X 25,5 X 1	305348	KG5107				
	20,5 X 26,2 X 1,5	321913	KG5195				
	20,5 X 28 X 2	310020	KG5125				
21	21 X 30 X 1,5	311482	KG5142				
	21,2 X 25,5 X 1	322344	KG5222				
	21,5 X 25 X 2	321912	KG5194				
22	22 X 26 X 1	322356	KG5225				
	22 X 28 X 1,5	321679	KG5184				
	22 X 29 X 1	321408	KG5178				
	22,1 X 26,9 X 1,5	311825	KG5148				
	22,2 X 30 X 1,5	305338	KG5106				
	22,4 X 30 X 1	322010	KG5210				
	22,5 X 27 X 1	310998	KG5135				
	22,5 X 27,7 X 1	311874	SUPP				
	22,5 X 29 X 1	322064	KG5217				
	22,5 X 30 X 2	309444	KG5123				
	22,7 X 26,8 X 2	322367	KG5229				
23	23 X 34,5 X 1,5	322031	KG5216				
	23,4 X 31 X 1	300036	KG5086				
24	24 X 29 X 1	300007	KG5079				
	24 X 29 X 1,5	311481	KG5141				
	24 X 30 X 1	321849	KG5192				
	24 X 32,5 X 2	322368	KG5230				

JOINTS MÉTALLOPLASTIQUES FERMÉS - COPPER/FIBRE WASHERS

JOINTS REPLIÉS - COPPER SEALS

Jointes métaloplastiques fermés se composent d'un garnissage plastique recouvert d'une enveloppe métallique ductile.
Résistance thermique : Jusqu'à environ 350°C

COFFRET KK5182 (P019 064100) JOINTS MÉTALLOPLASTIQUES FERMÉS

QTE	REF. PAYEN	DIM.
20	KG5039	6.2 X 10 X 2
20	KG5024	8.2 X 12 X 2
20	KG5019	9.2 X 14 X 2
20	N/A	10.2 X 14 X 2
20	KG5041	11.2 X 16 X 2
20	PA331	12.2 X 17 X 2
40	KG5009	14.1 X 19 X 2.5
40	PA349	16.3 X 22 X 2
20	KJ647	18.3 X 23 X 2
10	KG5042	20.4 X 26 X 2
10	KG5055	22.4 X 29 X 2

MÉTALLO FERMÉS PAR DIMENSIONS			MÉTALLO FERMÉS PAR DIMENSIONS		
DIM.	REF. PAYEN		DIM.	REF. PAYEN	
6,2 X 10 X 2	212367	KG5039	21 X 26 X 2	211983	KG5035
7,2 X 11 X 2	212368	KG5040	22 X 28 X 3	205038	PB853
8,2 X 12 X 2	206634	KG5024	22 X 30 X 3	211987	KG5037
9,2 X 14 X 2	202838	KG5019	22,3 X 26,8 X 2	211985	KG5036
10,2 X 16 X 2	209875	KG5027	23 X 29,8 X 4	210507	KG5028
11,2 X 16 X 2	212369	KG5041	24,2 X 30 X 3	205039	KG5022
12 X 16 X 2	211964	KG5033	24,4 X 32 X 2	209556	KG5026
12,2 X 17 X 2	202947	PA331	25 X 32 X 2	206311	KG5023
13,4 X 18 X 2	212390	KG5048	26 X 32 X 2	212406	KG5050
14,1 X 19 X 2,5	205035	KG5009	26 X 36 X 3	212407	KG5051
14 X 21 X 2	224504	PB907"	26,4 X 30 X 2	211238	KG5031
14,3 X 19 X 2	211172	KG5030	27,4 X 35 X 2	212373	KG5043
16 X 23 X 3	211973	SUPP	28,5 X 38 X 1,5	211993	KG5038
16,3 X 22 X 2	212370	PA349	30,2 X 36 X 3	209511	KG5025
16,3 X 24 X 3	211974	KG5034	30,4 X 38 X 2	212374	KG5044
17 X 23 X 2	212396	KG5049	32 X 40 X 2	200001	KG5018
18,1 X 24 X 3	205037	KG5021	32,4 X 41 X 2	206310	PB258
18,3 X 24 X 2	208832	KJ647	33,4 X 41 X 2	212375	KG5045
20 X 25,4 X 2	210725	KG5029	36,4 X 44 X 2	212376	KG5046
20,4 X 26 X 2	212371	KG5042	42,4 X 50 X 2	212377	KG5047

JOINTS REPLIÉS (OUVERTS) JOINT EN CUIVRE RECUIT REPLIÉ PERMET UNE BONNE RÉSISTANCE À L'ÉCRASEMENT RÉSISTANCE THERMIQUE : JUSQU'À 350°C

DIM.	REF. PAYEN	
8,2 X 13 X 1,8	230001	KG5052
10,2 X 15 X 2	230002	KG5053
12,2 X 17X2	230003	KG5054
14,25 X 20X 2	230005	KG5056
16,3 X 24X 2	230006	KG5057
18,3 X 24 X 2	230007	KG5058
22,4 X 29 X2	230004	KG5055

JOINTS FIBRE - FIBRE SEALS

JO Fibre de la série 600 000 = Fibre vulcanisée
Ces joints acceptent moins de serrage que les joints métalliques
Résistance thermique : Jusqu'à 150°C

JOINTS FIBRE PAR DIMENSIONS			JOINTS FIBRE PAR DIMENSIONS		
DIM.		REF. PAYEN	DIM.		REF. PAYEN
4 X 8 X 1	611932	KG5297	13 X 18 X 2	611650	KG5293
5 X 9 X 1	611933	KG5298	14 X 18 X 2	611801	KG5296
5 X 9 X 1,5	621182	KG5303	14,1 X 20 X 1	605490	KG5281
6 X 10 X 1	603073	KG5276	14,1 X 23 X 1,5	622690	KG5309
7 X 11 X 1	620751	KG5302	14,2 X 19 X 1	606699	KG5283
8 X 12 X 1	605581	KG5282	14,2 X 20 X 1,5	611717	KG5294
8,2 X 14 X 1	605265	KG5278	14,3 X 19 X 1,5	610173	KG5288
10 X 14 X 1	605266	KG5279	14,4 X 20 X 2	610010	KG5286
10 X 16 X 1	611938	KG5299	14,5 X 22 X 2	611423	KG5292
10,2 X 16 X 1,5	622662	KG5308	16 X 22 X 2	611421	KG5291
11 X 16 X 1	611940	KG5300	16,2 X 21 X 2	622094	KG5305
12 X 17 1,5	609590	KG5284	17 X 23 X2	611727	KG5295
12 X 18 X 1	603143	KG5277	18,5 X 26 X 2	622649	KG5307
12 X 18 X 2	621765	KG5304	20,4 X27 X3	611324	KG5290
12,5 X 18 X 1,5	611132	KG5289	20,5 X26X1,5	620729	KG5301
12,5 X 20 X 2	610014	KG5287	22,5 X 28 X 1,5	622199	KG5306
13 X 18 X 1	605267	KG5280	30,5 X38X2	610009	KG5285

JOINTS ALUMINIUM - ALUMINIUM WASHERS

joints Aluminium : Dureté maxi 32 à 45 HB
Résistance thermique : Jusqu'à 300°C environ

JO.	DIM.	ANC. REF.	REF. PAYEN
6	6,2 X 10 X 1	331001	KG5240
8	8,2 X 12 X 1	331010	KG5241
12	12 X 16 X 1,6	331022	KG5242
	12,2 X 18 X 1,2	331023	KG5243
14	14,1 X 18 X1	331027	KG5244
	14,3 X 19 X 1,5	331051	KG5248
	14,7 X 20 X 1,6	331037	KJ247
16	16 X 24 X 1	331028	KG5245
18	18,5 X 24 X 1,5	331049	KG5246
	22,5 X29X 1,5	331050	KG5247

JOINTS CUIVRE - COPPER WASHERS

ASSORTIMENTS DE JOINTS & RONDELLES POUR INJECTION DIESEL

JOINTS CUIVRE : CUIVRE RECUIT POUR 1 DURETÉ MAXIMALE DE 50 HB - RÉSISTANCE THERMIQUE : 600°C ENVIRON
RÉF. KK5184 (EX. PO19065300)
CE COFFRET PERMET D'ÉQUIPER LES VÉHICULES FRANÇAIS EN JOINTS D'INJECTEURS ET JOINTS PARE-FEU
402 JOINTS D'INJECTION ET DE RACCORDS POUR MOTEURS DIESEL

QTE	REF. PAYEN	DIM.	ANC. REF.	MAT.	DES.
30	KG5117	6.2 X 10 X 1	P030628500	JOINT CUIVRE	JOINT RACCORD 6MM RENAULT
20	KG5087	14.7 X 21.4 X 1.95	P030003700	JOINT CUIVRE	JOINT INJECTEUR RENAULT J8S, F8Q
40	PA335	14.3 X 19 X 1.5	P031169400	JOINT CUIVRE	JOINT RACCORD DIA. 14
50	PA346	7.2 X 13.5 X 1.3	PO2008300	ACIER NERVURÉ	JOINT PARE-FEU BMW, CITROËN, FORD, PEUGEOT
20	KG5020	14.5 X 21.2 X 2	PO2374700	JOINT CUIVRE	JOINT INJECTEUR INDÉNOR
20	KG5091	16.2 X 20 X 1	P030231700	JOINT CUIVRE	JOINT RACCORD 16MM INDÉNOR
20	KG5085	14.5 X 21.3 X 1.8	P030003500	JOINT CUIVRE	JOINT INJECTEUR PSA CRD
40	KG5094	8 X 12 X 1	P030283000	JOINT CUIVRE	JOINT RACCORD DIA. 8MM (STANDARD)
20	PA345	15.6 X 21.2 X 2.2	P032069400	JOINT CUIVRE	JOINT INJECTEUR FORD
12	-	5.3 X 20.3 X 3.5	PO2527100	ACIER DÉCOLLETÉ	JOINT INJECTEUR AUDI, FIAT, SEAT, VW
40	KG5095	12.2 X 18 X 1	P030284400	JOINT CUIVRE	JOINT RACCORD DIA. 12
20	KJ920	14.5 X 20 X 2	P032235500	JOINT CUIVRE	JOINT INJECTEUR FIAT, SOFIM, VM
20	KG5081	12.2 X 17 X 2	P030001200	JOINT CUIVRE	JOINT INJECTEUR OPEL
50	-	5.1 X 13.5 X 1.3	PO2511000	ACIER NERVURÉ	JOINT PARE-FEU PSA CRD

ASSORTIMENT DE RONDELLES INJECTEURS
RÉF. KK5180 (EX. 190660/19058600)
144 JOINTS D'INJECTEUR

QTE	REF. PAYEN	DIM.	ANC. REF.
12	KG5117	6.2X10X1	306285
12	KG5094	8 X 12 X 1	30283
12	KG5219	10X13.9X1	322335
12	KG5095	12.2X18X 1	302844
12	PA335	14.3X19X1.5	311694
12	KG5220	14.5X21.3X1.5	322336
12	KG5197	15.5X20X2	321915
12	KG5196	16 X 24 X 1	321914
12	KG5182	18.2 X 23 X 1.5	321573
12	KG5195	20 X 26 X 1.5	321913
12	KG5222	21.2 X 25.5 X 1	322344
12	KG5225	22 X 26 X 1	322356

COFFRET SUPPRIME (ANC. REF. KK5183/ 190665)
QTTE 450
COMMANDER LES REF. A L'UNITE

QTE	REF. PAYEN	DIM.	ANC. REF.
50	KG5257	5 X 9 X 0,05	P0332015
50	KG5258	5 X 9 X 0,1	P0332016
50	KG5260	5,5 X 11,5X 0,05	P0332018
50	KG5261	5,5 X 11,5 X 0,1	P0332019
50	KG5266	6,5 X 11 X 0,05	P0332031
50	KG5267	6,5 X 11 X 0,1	P0332032
50	KG5269	7,5 X 13 X 0,05	P0332035
50	-	3,6 X 7,5 X 0,05	P0332119
50	-	3,6 X 7,5 X 0,1	P0332120

CALES DE TARAGE : PAR DIMENSIONS

QTE	DIM.	ANC. REF.	REF. PAYEN	QTE	DIM.	ANC. REF.	REF. PAYEN	QTE	DIM.	ANC. REF.	REF. PAYEN
3	3,6 X 7,5 X 0,05	332119			5 X 9 X 0,2	332017	KG5259		6,5 X 11 X 0,1	332032	KG5267
	3,6 X 7,5 X 0,1	332120			5,5 X 11,5 X 0,05	332018	KG5260		6,5 X 11 X 0,2	332033	KG5268
4	4 X 7 X 0,05	332001	KG5252		5,5 X 11,5 X 0,1	332019	KG5261		6,5 X 11 X 0,5	332034	
	4 X 7 X 0,1	332002	KG5253		5,5 X 11,5 X 0,2	332020	KG5262		6,5 X 13,4 X 0,05	332101	KG5274
	4,9 X 9,5 X 0,05	332010	KG5254		5,5 X 11,5 X 0,5	332021			6,5 X 13,4 X 0,1	332102	
	4,9 X 9,5 X 0,1	332011	KG5255	6	6 X 10 X 0,05	332026	KG5263		6,5 X 13,4 X 0,2	332103	
	4,9 X 9,5 X 0,2	332012	KG5256		6 X 10 X 0,1	332027	KG5264	8	8,2 X 14 X 0,1	332045	KG5272
	4,9 X 9,5 X 1	332014			6 X 10 X 0,2	332028	KG5265		8,2 X 14 X 0,2	332046	
5	5 X 9 X 0,05	332015	KG5257		6 X 10 X 0,5	332029		12	12,4 X 18 X 1	332098	KG5273
	5 X 9 X 0,1	332016	KG5258		6,5 X 11 X 0,05	332031	KG5266				

JOINTS CUIVRE - COPPER WASHERS

RONDELLES POUR INJECTEURS

ASSORTIMENT DE 138 RONDELLES INJECTEURS KK5179 (EX.P019058300)

QTE	QTE	ANC. REF.	REF. PAYEN
12	14.5 X 23 X 2	903900	-
12	8 X 12 X 1	302830	KG5094
12	12.2 X 18 X 1	302844	KG5095
12	14.2 X 21.8 X 2	309012	KG5122
6	14.4 X 24.5 X 4	310684	-
12	14.3 X 19 X 1.5	311694	PA335
12	18.2 X 23 X 1.5	321573	KG5182
12	10.2 X 13.9 X 1	322335	KG5219
12	14.5 X 21.3 X 1.5	322336	KG5220
12	21.2 X 25.5 X 1	322344	KG5222
12	22 X 26 X 1	322356	KG5225
12	9.5 X 21 X 1.5	190438	-

GAMME EUROPÉENNE RÉF. KK5180 (EX.P019058600) 144 JOINTS D'INJECTEUR

QTE	REF. PAYEN	DIM.	ANC. REF.
12	KG5094	8 X 12 X 1	P030283000
12	KG5095	12.2 X 18 X 1	P030284400
12	KG5117	6.2 X 10 X 1	P030628500
12	PA335	14.3 X 19 X 1.5	P031169400
12	KG5182	18;2 X 23 X 1.5	P032157300
12	KG5195	20 X 26 1.5	P032191300
12	KG5196	16 X 24 X 1	P032191400
12	KG5197	15.5 X 20 X 2	P032191500
12	KG5219	10.2 X 13.9 X 1	P032233500
12	KG5220	14.5 X 21.3 X 1.5	P032233600
12	KG5222	21.2 X 25.5 X 1	P032234400
12	KG5225	22 X 26 X 1	P032235600

JOINTS TORIQUES - O'RINGS

QTE	DIAM. INT.	ANC. RÉF	RÉF. PAYEN	MAT.	QTE	DIAM. INT.	ANC. RÉF	RÉF. PAYEN	MAT.	QTE	DIAM. INT.	ANC. RÉF	RÉF. PAYEN	MAT.
2	2,6 X 1,9	015001	LA5020	NBR	20	20 X 2	015589	LA5110	NBR	50,17	X 5,33	015032	LA5047	NBR
3	3,4 X 1,9	015002	LA5021	NBR		20,22 X 3,53	015116	LA5074	NBR	50,39	X 3,53	015539	LA5101	NBR
4	4,2 X 1,9	015003	LA5022	NBR		20,3 X 2,6	015604	LA5116	NBR	52	52 X 2	015642	PA434	NBR
	4,9 X 1,9	015004	LA5023	NBR	21	21,3 X 3,6	015017	LA5032	NBR		52 X 3	015629	PA625	NBR
5	5,28 X 1,78	015104	LA5062	NBR		21,82 X 3,53	015117	LA5075	NBR	53	53,34 X 5,33	015033	LA5048	NBR
	5,7 X 1,9	015005	LA5024	NBR	22	22 X 2	015717	LA5135	NBR		53,97 X 3,53	0155580	LA5105	NBR
6	6,07 X 1,78	015105	LA5063	NBR		22 X 2,7	015668	LA5126	NBR	54	54,3 X 1,9	015750	PA370	NBR
	6,35 X 2,4	015596	LA5013	NBR		22,5 X 2,7	015303	LA5086	NBR		54,5 X 3	015540	LA5102	NBR
	6,5 X 2,7	015907	LA5142	ACM	23	23 X 3	015523	LA5092	NBR	56	56,2 X 5,33	015034	LA5049	NBR
7	7,2 X 1,9	015106	LA5025	NBR		23 X 3,6	015018	LA5033	NBR	58	58 X 3	015728	LA5138	NBR
	7,5 X 3,25	015501	LA5087	NBR		23,39 X 3,53	015118	LA5076	NBR		58,6 X 7	015729	LA5139	NBR
	7,65 X 1,78	015106	LA5064	NBR		23,4 X 3,5	015585	LA5107	NBR	59	59,69 X 5,33	015035	LA5050	NBR
8	8 X 2	015586	LA5108	NBR		23,5 X 1,75	015703	LA5132	NBR	60	60 X 3	015541	LA5103	NBR
	8,5 X 1,5	015505	LA5088	NBR	24	24 X 2	015524	LA5093	NBR	62	62 X 3	015634	LA5119	NBR
	8,5 X 2,5	015908		ACM		24,6 X 3,6	015019	LA5034	NBR		62,87 X 5,33	015036	LA5051	NBR
	8,9 X 1,9	015007	LA5026	NBR		24,99 X 3,53	015119	LA5077	NBR	63	63,1 X 3,53	015723	LA5137	NBR
9	9,19 X 2,62	015108	LA5066	NBR	25	25 X 2,50	015525	LA5094	NBR	65	65 X 3	015706	LA5133	NBR
	9,25 X 1,78	015107	LA5065	NBR		25,1 X 3,6	015695	LA5131	NBR	69	69,22 X 5,33	015038	LA5052	NBR
	9,5 X 6	015684	LA5129	NBR	26	26,2 X 3	015527	LA5095	NBR	72	72 X 3	015688	LA5130	NBR
10	10 X 2	015672	LA5127	NBR		26,2 X 3,6	01502	LA5035	NBR		72,39 X 5,33	015039	LA5053	NBR
	10 X 3	015587	LA5109	NBR		26,57 X 3,53	015120	LA5078	NBR	75	75,57 X 5,33	015040	LA5054	NBR
	10,5 X 2,7	015009	PA172	NBR	27	27 X 2	015638	LA5121	NBR	78	78,74 X 5,33	015041	LA5055	NBR
	10,77X2,62	015109	LA5067	NBR		27,5 X 3	01528	LA5096	NBR	85	85 X 3,5	015590	LA5111	NBR
11	11,11 X 1,78	015509	LA5089	NBR		27,8 X 3,6	015021	LA5036	NBR		85,09 X 5,33	015043	LA5056	NBR
12	12 X 2	015735	LA5141	NBR	28	28,17X3,53	015121	LA5079	NBR	88	88,27 X 5,33	015044	LA5057	NBR
	12 X 3	015510	LA5090	ACM	29	29,3 X 3,6	015022	LA5037	NBR	90	90 X 3	015730	LA5140	NBR
	12,1 X 1,9	015751	PA371	NBR		29,74X3,53	015122	LA5080	NBR	91	91 X 3	015720	LA5136	NBR
	12,1 X 2,7	015010	LA5027	NBR	30	30,2 X 3	015678	KJ651	NBR		91,44 X 5,33	015045	LA5058	NBR
	12,37 X 2,62	015110	LA5068	NBR		30,3 X 2,4	015530	LA5097	NBR	94	94,62 X 5,33	015046	LA5059	NBR
13	13 X 2,5	015917	LA5143	ACM		30,8 X 3,6	015023	LA5038	NBR	99	99 X 3	015683	PA714	NBR
	13,3 X 2,4	015512	LA5091	NBR	31	31,34 X 3,53	015123	LA5081	NBR	100	100 X 2	015698		NBR
	13,6 X 2,7	015011	PA173	NBR	32	32,5 X 3,6	015024	LA5039	NBR		100,97 X 5,33	015048	LA5060	NBR
	13,94X2,62	015111	LA5069	NBR		32,92 X 3,53	015124	LA5082	NBR	104	104 X 3	015690	PA706	NBR
14	14 X 2	015630	LA5117	NBR	34	34 X 1,9	015749	PA369	NBR	110	110 X 3	015557	PA711	NBR
15	15,1 X 2,7	015012	LA5028	NBR		34,1 X 3,6	015025	LA5040	NBR	112	112 X 3	015611	PA713	NBR
	15,2 X 1,78	015655	LA5123	NBR		34,52 X 3,53	015125	LA5083	NBR	113	113,67 X 5,33	015052	LA5061	NBR
	15,54X2,62	015112	LA5070	NBR	35	35 X 2,5	015603	LA5115	NBR	116	116 X 3	015562	LA5104	NBR
	15,9 X 2,62	015652	LA5122	NBR		35 X 3	015631	LA5118	NBR	125	125 X 4,2	015566	PA705	NBR
16	16,7 X 2,5	015584	LA5016	NBR		35,6 X 3,6	015026	LA5041	NBR	126	126 X 3	015682	LA5128	NBR
	16,9 X 2,7	015013	LA5029	NBR	36	36,09 X 3,53	015126	LA5084	NBR		126 X 3	015922	PA709	ACM
17	17 X 2,5	015707	LA5134	NBR	37	37,3 X 3,6	015027	LA5042	NBR	129	129 X 2	015913	PA708	ACM
	17,12 X 2,62	015113	LA5071	NBR		37,47 X 5,33	015028	LA5043	NBR	142,47	142,47 X 3,53	015742	PA712	NBR
	17,17 X 1,78	15657	LA5125	NBR		37,69 X 3,53	015127	LA5085	NBR					
18	18 X 2	015637	LA5120	NBR	38	38,9 X 2,7	015601	LA5114	NBR					
	18,3 X 3,6	015015	LA5030	NBR	40	40,64 X 5,33	015029	LA5044	NBR					
	18,4 X 2,7	015014	PA326	NBR	43	43,82 X 5,33	015030	LA5045	NBR					
	18,64X3,53	015115	LA5073	NBR	44	44 X 3	015664	JB881	NBR					
	18,7 X 1,78	015656	LA5124	NBR		44,1 X 5	015535	LA5098	NBR					
	18,7 X 1,9	015722	PA177	NBR	46	46,6 X 5,3	015031	LA5046	NBR					
	18,72X2,62	015114	LA5072	NBR	48	48 X 3,6	015536	LA5099	NBR					
19	19,4 X 2,7	015665	PA175	NBR	49	49 X 3	015537	LA5100	NBR					
	19,8 X 3,6	015016	LA5031	NBR	50	50 X 3	015992	LA5112	NBR					

ASSORTIMENTS DE JOINTS TORIQUES - O'RINGS KITS

JOINTS TORIQUES 2,6 À 18 - COFFRET RÉF. LA5156 (EX.RÉF. 19060100)

REF. PAYEN	QTE	DIM.	ANC. REF.	REF. PAYEN	QTE	DIM.	ANC. REF.	REF. PAYEN	QTE	DIM.	ANC. REF.
LA5020	20	2,6 X 1,9	1500100	LA5088	20	8,5 X 1,5	1550500	LA5123	10	15,2 X 1,78	1565500
LA5021	20	3,4 X 1,9	1500200	LA5065	20	9,2 X 1,7	1510700	LA5122	10	15,9 X 2,62	1565200
LA5022	20	4,2 X 1,9	1500300	LA5109	20	10 X 3	1558700	LA5016	5	16,7 X 2,5	1558400
LA5023	20	4,9 X 1,9	1500400	PA172	20	10,5 X 2,7	1500900	LA5125	5	17,17 X 1,78	1565700
LA5024	20	5,7 X 1,9	1500500	LA5089	10	11,1 X 1,78	1550900	LA5120	5	18 X 2	1563700
LA5113	20	6,35 X 2,4	1559600	LA5027	10	12,1 X 2,7	1501000	PA326	5	18,4 X 2,7	1501400
LA5025	20	7,2 X 1,9	1500600	LA5091	10	13,3 X 2,4	1551200	LA5124	5	18,7 X 1,78	1565600
LA5108	20	8 X 2	1558600	LA5117	10	14 X 2	1563000	LA5110	5	20 X 2	1558900

JOINTS TORIQUES 19,8 À 50,17 - COFFRET RÉF. LA5157 (EX.RÉF. 19060200)

REF. PAYEN	QTE	DIM.	ANC. REF.	REF. PAYEN	QTE	DIM.	ANC. REF.	REF. PAYEN	QTE	DIM.	ANC. REF.
LA5116	10	20,3 X 2,6	1560400	LA5035	10	26,2 X 3,6	1502000	LA5039	5	32,5 X 3,6	1502400
LA5032	10	21,3 X 3,6	1501700	LA5121	10	27 X 2	1563800	LA5040	10	34,1 X 3,6	1502500
LA5092	10	23 X 3	1552300	LA5096	10	27,5 X 3	1552800	LA5083	5	34,52 X 3,53	1512500
LA5107	10	23,4 X 3,5	1558500	LA5036	10	27,8 X 3,6	1502100	LA5115	10	35 X 2,5	1560300
LA5093	10	24 X 2	1552400	LA5079	10	28,17 X 3,53	1512100	LA5118	5	35 X 3	1563100
LA5034	10	24,6 X 3,6	1501900	LA5037	10	29,3 X 3,6	1502200	LA5041	5	35,6 X 3,6	1502600
LA5094	10	25 X 2,5	1552500	LA5097	10	30,3 X 2,4	1553000	LA5042	10	37,3 X 3,6	1502700
LA5095	10	26,2 X 3	1552700	LA5038	10	30,8 X 3,6	1502300	LA5114	10	38,9 X 2,7	1560100

JOINTS TORIQUES 5,28 À 31,34 - COFFRET RÉF. LA5155 (EX.RÉF. 1906000)

REF. PAYEN	QTE	DIM.	ANC. REF.	REF. PAYEN	QTE	DIM.	ANC. REF.	REF. PAYEN	QTE	DIM.	ANC. REF.
LA5062	10	5,2 X 1,7	1510500	LA5070	10	15,54 X 2,62	1511200	LA5078	10	26,57 X 3,53	1512000
LA5063	10	6,07 X 1,78	1510500	LA5071	10	17,12 X 2,62	1511300	LA5079	10	28,1 X 3,53	1512100
LA5064	10	7,65 X 1,78	1510600	LA5072	10	18,72 X 2,62	1511400	LA5080	10	29,74 X 3,53	1512200
LA5065	10	9,25 X 1,78	1510700	LA5073	10	18,64 X 3,53	1511500	LA5081	10	31,34 X 3,53	1512300
LA5066	10	9,19 X 2,62	1510800	LA5074	10	20,22 X 3,53	1511600	LA5082	10	32,92 X 3,53	1512400
LA5067	10	10,77 X 2,62	1510900	LA5075	10	21,82 X 5,33	1511700	LA5083	5	34,52 X 3,53	1512500
LA5068	10	12,37 X 2,62	1511000	LA5076	10	23,39 X 3,53	1511800	LA5084	5	36,09 X 3,53	1512600
LA5069	10	13,94 X 2,62	1511100	LA5077	10	24,99 X 3,53	1511900	LA5085	5	37,69 X 3,53	1512700

JOINTS TORIQUES 5,70 À 29,30 - COFFRET DE 300 JOINTS-RÉF. LA5159 (EX.RÉF.190643)

REF. PAYEN	QTE	DIM.	ANC. REF.	REF. PAYEN	QTE	DIM.	ANC. REF.	REF. PAYEN	QTE	DIM.	ANC. REF.
LA5024	20	5,7 X 1,9	1500500	PA173	20	13,6 X 2,7	1501100	LA5032	10	21,3 X 3,6	1510700
LA5025	20	7,2 X 1,9	1500600	LA5028	20	15,1 X 2,7	1501200	LA5033	10	23 X 3,6	1501800
LA5026	20	8,9 X 1,9	1500700	LA5029	20	16,9 X 2,7	1501300	LA5034	10	24,6 X 3,6	1501900
PA171	20	8,9 X 2,7	1500800	PA326	20	18,4 X 2,7	1501400	LA5035	10	26,2 X 3,6	1502000
PA172	20	10,5 X 2,7	1500900	LA5030	20	18,3 X 3,6	1501500	LA5036	10	27,8 X 3,6	1502100
LA5027	20	12,1 X 2,7	1501000	LA5031	20	19,8 X 3,6	1501600	LA5037	10	29,3 X 3,6	1502200

JOINTS TORIQUES 44,10 À 62,87 - COFFRET DE 60 JOINTS- RÉF. LA5158 (EX.RÉF. 190603)

REF. PAYEN	QTE	DIM.	ANC. REF.	REF. PAYEN	QTE	DIM.	ANC. REF.	REF. PAYEN	QTE	DIM.	ANC. REF.
LA5098	5	44,1 X 5	15535	LA5101	5	50,39 X 3,53	15539	LA5049	5	56,2 X 5,33	15034
LA5099	5	48 X 3,6	15536	PA625	5	52 X 3	15629	LA5103	5	60 X 3	15541
LA5100	5	49 X 3	15537	LA5105	5	53,97 X 3,53	15580	LA5119	5	62 X 3	15634
LA5112	5	50 X 3	15592	LA5102	5	54,5 X 3	15540	LA5051	5	62,87 X 5,33	15036

JOINTS DE BOUCHON DE VIDANGE - OIL DRAIN PLUG WASHERS

M = MÉTALLOPLASTIQUE FERMÉS

CU = CUIVRE

AL = ALUMINIUM

NYL = NYLON

FIB = FIBRE

TOR = TORIQUE

BS = BAGUES BS (AUTOCENTRÉES)

COMPOSÉES DE RONDELLES ACIER ET D'UN CORDON ÉLASTOMÈRE

CLASSEMENT PAR RÉFÉRENCE

REF. PAYEN	DIM.	MAT.
LA5120	18X2	TOR
PA217	16,3X22X1	CU
PA331	12,2X17X2	M
PA349	16,3X22X2	M
PA401	14,5X20X1,5	CU
PB852	16X24X1,5	BS
PB907	14X21X2	M
KG5011	14 X 21 X 1,5	BS
KG5012	16X23X1,5	BS
KG5030	14,3X19X2	M
KG5032	14,2 X 8,3 X 1,3	BS
KG5050	26 X 32 X 2	CU
KG5111	26,1X32X1	CU
KG5125	20,5X28X2	CU
KG5126	18,5X26X2	CU
KG5148	22,1X26,9X15	CU
KG5156	19,3X23,9X1,5	CU
KG5157	10,1X20,8X2	CU
KG5158	18,3X 24X1,5	CU
KG5162	12,2X15,9X1,5	CU
KG5195	20X26X1,5	CU
KG5207	16X23,6X1,5	CU
KG5215	26,3X33X3	CU
KG5232	14,2X22X1	CU
KG5242	12X16X1,6	AL
KG5247	22,5X29X1,5	AL
KG5248	14,3X19X1,5	AL
KG5249	14,9X22,2X2	NYL
KG5290	20,4X27X3	FIB
KG5292	14,5X22 X 2	FIB
KG5313	13X22,5X3	BS
KJ647	18,3X23X2	M
KJ920	14,5X20,2	CU

CLASSEMENT PAR DIMENSIONS

REF. PAYEN	DIM.	MAT.
KG5157	10,1 X 20,8 X 2	CU
KG5242	12 X 16 X 1,6	AL
KG5162	12,2 X 15,9 X 1,5	CU
PA331	12,2 X 17 X 2	M
KG5313	13 X 22,5 X 3	BS
PB907	14 X 21 X 2	M
KG5011	14 X 21 X 1,5	BS
KG5232	14,2 X 22 X 1	CU
KG5032	14,2 X 8,3 X 1,3	BS
KG5248	14,3 X 19 X 1,5	AL
KG5030	14,3 X 19 X 2	M
KJ920	14,5 X 20,2	CU
PA401	14,5 X 20 X 1,5	CU
KG5292	14,5X22 X 2	FIB
KG5249	14,9 X 22,2 X 2	NYL
KG5012	16 X 23 X 1,5	BS
KG5207	16 X 23,6 X 1,5	CU
PB852	16 X 24 X 1,5	BS
PA217	16,3 X 22 X 1	CU
PA349	16,3 X 22 X 2	
KG5158	18, X 24 X 1,5	CU
KG5013	18, X 27 X 2	BS
LA5120	18 X 2	TOR
KJ647	18,3 X 23 X 2	M
KG5126	18,5X26X2	CU
KG5156	19,3 X 23,9 X 1,5	CU
KG5290	20,4 X 27 X 3	FIB
KG5125	20,5 X 28 X 2	CU
KG5195	20 X 26 X 1,5	CU
KG5148	22,1 X 26,9 X 15	CU
KG5247	22,5 X 29 X 1,5	AL
KG5111	26,1 X 32 X 1	CU
KG5215	26,3 X 33 X 3	CU
KG5050	26 X 32 X 2	M

COFFRETS JOINTS DE BOUCHON DE VIDANGE - OIL DRAIN PLUG WASHERS KITS

COFFRET 290 JOINTS DE BOUCHONS DE VIDANGE PSA/RENAULT HR525 (EX. PO19064700)

QTE	REF. PAYEN	DIM.	ANC. REF.	APPL.	MAT.
100	PA349	16,3X22X2	PO21237000	CITROËN, PEUGEOT, RENAULT	MÉTALLOPLASTIQUE FERMÉ
40	KG5290	20,4X27X3	PO61132400	TALBOT	FIBRE
50	KG5009	14,1X19X2,5	PO20503500	SIMCA	MÉTALLOPLASTIQUE FERMÉ
100	KJ647	18,3X23X2	PO20883200	RENAULT, MITSUBISHI	MÉTALLOPLASTIQUE FERMÉ

JOINTS MÉTALLOPLASTIQUES FERMÉS (M)

REF. PAYEN	DIM.	ANC. REF.
PA331	12,2 X 17 X 2	202947
PB907	14 X 21 X 2	224504
KG5030	14,3 X 19 X 2	211172
PA349	16,3 X 22 X 2	212370
KJ647	18,3 X 23 X 2	208832
PB853	22 X 28 X 3	205038
KG5026	24,4X32X 2	209556
KG5050	26 X 32 X 2	212406

JOINTS CUIVRE (CU)

REF. PAYEN	DIM.	ANC. REF.
KG5157	10,1 X 20,8 X 2	320347
KG5162	12,2 X 15,9 X 1,5	320693
KG5081	12,2 X 17 X 2	300012
KG5232	14,2 X 22 X 1	322393
PA401	14,5X20X1,5	311136
KJ920	14,5 X 20 X 2	322355
KG5207	16 X 23,6 X 1,5	321998
PA217	16,3 X 22 X 1	310141
KG5158	18,3 X 24 X 1,5	320383
KG5126	18,5 X 26 X 2	310021
SUPP	19,2 X 24,9 X 2	321852
KG5156	19,3 X 23,9 X 1,5	320117
KG5195	20 X 26 X 1,5	321913
KG5125	20,5 X 28 X 2	310020
KG5148	22,1X26,9X1,5	311825
KG5111	26,1 X 32 X 1	305359
KG5215	26,3 X 33 X 3	322028

JOINT FIBRE (FIB)

REF. PAYEN	DIM.	ANC. REF.
KG5290	20,4 X 27 X 3	611324

JOINT NYLON (NYL)

REF. PAYEN	DIM.	ANC. REF.
KG5249	14,9 X 22,2 X 2	331052

BAGUES "BS" (BS)

REF. PAYEN	DIM.	ANC. REF.
KG5011	14 X 21 X 1,5	PO2526800
SUPP	14 X 24 X 1,5	25345
KG5032	14,2 X 8,3 X 1,3	PO2118700
KG5012	16 X 23 X 1,5	PO2526900
PB852	16 X 24 X 1,5	PO2534000
SUPP	16,3 X 22 X 1	25346
KG5013	18 X 27 X 2	PO2527000
SUPP	20 X 28 X 1,5	25342
SUPP	20,5 X 28 X 2	25339

ASSORTIMENTS - KITS

COFFRET 260 JOINTS MÉTALLOPLASTIQUES FERMÉS ET JOINTS REPLIÉS (CUIVRE) KK5182 (ANC. REF. 190641)

QTE	REF. PAYEN	DIM.	ANC. REF.	MAT.
20	KG5039	6,2 X 10 X 2	212367	MÉTALLO FERMÉ
20	KG5040	7,2 X 11 X 2	212368	MÉTALLO FERMÉ
20	KG5024	8,2 X 12 X 2	206634	MÉTALLO FERMÉ
20	KG5019	9,2 X 14 X 2	202838	MÉTALLO FERMÉ
20	KG5053	10,2 X 15 X 2	230002	JOINT REPLIÉ
20	KG5041	11,2 X 1 X 2	212369	MÉTALLO FERMÉ
20	PA331	12,2 X 17 X 2	202947	MÉTALLO FERMÉ
40	KG5009	14,1X19X 2,5	205035	MÉTALLO FERMÉ
40	PA349	16,3X22X 2	212370	MÉTALLO FERMÉ
20	KJ647	18,3X23X 2	208832	MÉTALLO FERMÉ
10	KG5042	20,4X26X 2	212371	MÉTALLO FERMÉ
10	KG5055	22,4X29X 2	230004	JOINT REPLIÉ

COFFRET 350 RONDELLES EN FIBRE HR524 (ANC. REF. 190642)

QTE	REF. PAYEN	DIM.	ANC. REF.
40	KG5298	5X9X1	611933
40	KG5276	6X10X1	603073
40	KG5302	7X11X1	620751
40	KG5278	8,2X14X1	605265
40	KG5308	10,2X16X1,5	622662
20	KG5300	11X16X1	611940
20	KG5289	12,5X18X1,5	611132
20	KG5280	13 X 18 X 1	605267
20	KG5283	14,2X19X1	606699
20	KG5286	14,4X20X2	610010
10	KG5305	16,2X21X2	622094
10	KG5295	17X23X2	611727
10	KG5307	18,5X26X2	622649
10	KG5301	22,5X28X1,5	620729
10	KG5306	22,5X28X1,5	622199

COFFRET 600 JOINTS CUIVRE ET FIBRE (SERVICE DIESEL) KK5181 (ANC. REF. 190610)

QTE	REF. PAYEN	DIM.	ANC. REF.	MAT.
20	KG5117	6,2 X 10 X 1	306285	CUIVRE
50	KG5094	8 X 12 X 1	302830	CUIVRE
20	KG5108	8,2 X 14 X 1	305356	CUIVRE
20	KG5150	9,7X 14,2X 1,8	311858	CUIVRE
20	KG5219	10,2 X13,9 X 1	322335	CUIVRE
20	KG5162	12,2X15,9X1,5	320693	CUIVRE
20	KG5206	12,5 X 16,8 X 1	321989	CUIVRE
50	PA335	14,3X19X1,5	311694	CUIVRE
20	KG5020	14,5 X21,2X 2	237470	CUIVRE
20	KG5220	14,5X21,3 X1,5	322336	CUIVRE
20	KG5197	15,5 X 20 X 2	321915	CUIVRE
20	PA345	15,6 X 21,2 X 2,2	320694	CUIVRE
20	KG5091	16,2 X 20 X 1	302317	CUIVRE
20	KG5231	18,2 X 22 X 1,5	322375	CUIVRE
20	KG5195	20 X 26 X 1,5	321913	CUIVRE
20	KG5225	22 X 26 X 1	322356	CUIVRE
20	KG5298	5X9X1	611933	FIBRE
50	KG5276	6X10X1	603073	FIBRE
20	KG5278	8,2X14X1	605265	FIBRE
20	KG5308	10,2X16X1,5	622662	FIBRE
20	KG5289	12,5X18X1,5	611132	FIBRE
20	KG5309	14,1X23X1,5	606690	FIBRE
50	KG5286	14,4X20X2	610010	FIBRE
20	KG5307	18,5X26X2	622649	FIBRE

"COFFRET 250 JOINTS CUIVRE" HR522 (ANC. REF. 190608)

QTE	REF. PAYEN	DIM.	ANC. REF.
20	KG5101	5,2 X 8 X 1	305231
20	KG5117	6,2 X 10 X 1	306285
20	KG5103	7,2 X 11 X 1	305317
20	KG5102	8,5 X 17 X 1	305243
20	KG5115	9,2 X 20 X 1	306234
20	PA333	10,1 X 18 X 1	302290
20	KG5074	11 X 20 X 1	300001
20	KG5093	12,5 X 20 X 0,8	302466
20	KG5134	13,7 X18,5X1	310861
20	KG5110	14,2 X 20 X1	305358
10	KG5118	15 X 24 X 1	306308
10	KG5091	16,2 X 20 X 1	302317
10	KG5096	17 X 21 X 1	302910
10	KG5098	18,5 X 23 X 1	302920
10	KG5090	20,1 X 26 X 1	302298

CALES DE TARAGE POUR INJECTEURS

KK5183 ANC. RÉF.19064900 = SUPPRIMÉ RÉF. VENDUES AU DÉTAIL

COFFRET "SERVICE" 700 JOINTS ASSORTIMENT SERVICE, ENTRETIEN ET RÉPARATION HR523 (ANC. REF. 190611)

RONDELLES CUIVRE

QTE	REF. PAYEN	DIM.	ANC. REF.
50	KG5094	8 X 12 X 1	302830
50	PA333	10,1 X 18 X 1	302290
20	KG5206	12,5X16,8 1	321989
50	PA401	14,5X20X1,5	311136
20	PA217	16,3X22X1	310141
20	KG5182	18,2X23X1,5	321573
20	KG5195	20X26X1,5	321913
20	KG5148	22,2X26,9X1,5	311825

RONDELLES FIBRE

QTE	REF. PAYEN	DIM.	ANC. REF.
20			603329
20			605579
20			611717
50	KG5278	8,2X14X1	605265
50	KG5308	10,2X16X1,5	622662
20	KG5277	12X18X1	603143
50	KG5294	14,2X20X1,5	611717
20	KG5307	18,5X26X2	622649

JOINTS CIRCULAIRES FERMÉS

QTE	REF. PAYEN	DIM.	ANC. REF.
20	KG5024	8,2X12X2	206634
20	KG5053	10,2X15X2	230002
20	KG5033	12X16X2	211964
50	KG5030	14,3X19X2	211172
20	PA349	16,3X22X2	212370
30	KJ647	18,3X23X2	208832
20	KG5042	20,4X26X2	212371
20	PB853	22X28X3	205038

TECHNICAL NOTES

Technische Hinweise • Notes techniques
Notas técnicas



1	Spring Seat Type	Federtypen	Types ressortes	Tipos resortes
2	Oil Seal, wheel hub	Wellendichtring, Radnabe	Bague d'étanchéité, moyeu de roue	Anillo retén, cubo de rueda
3	Integrated seal & housing	Integrierte Dichtung und Gehäuse	Plaque avant avec bague intégrée	Retén de Carcasa
4	Std bore	Standardbohrung	Alésage standard	Diámetro interior estándar
5	Oil Pan Material: Aluminium	Ölwanne material: alu	Matériel pour carter d'huile: aluminium	Material cárter: aluminio
6	Oil Pan Material: Steel	Ölwanne material: Stahl	Matériel pour carter d'huile: acier	Material cárter: Acero
7	with JP067	Mit JP067	Contient JP067	Contiene JP067
8	Supplementary Article/Supplementary Info 2: without oil pan gasket	Ergänzungsartikel / Ergänzende Info 2: ohne Ölwanndichtung	Article complémentaire / Info complémentaire 2: sans joint de carter d'huile	Artículo complementario/ Información complementaria 2: sin junta de cárter de aceite
9	For engines with glow plugs fitted vertically	Für Motoren mit vertikal eingebauten Glühkerzen	Pour moteur à bougies verticales	Para motores con verificador de calentadores
11	Gasket, timing case	Steuergehäusedichtung	Joint de carter de distribution	Junta de cárter de distribución
12	Supplementary Article/Supplementary Info: Without crankshaft seal	Ergänzungsartikel / Ergänzende Info: ohne Wellendichtring-Kurbelwelle	Article complémentaire / Info complémentaire: sans bague d'étanchéité - vilebrequin	Artículo complementario/Información complementaria: sin cigüeñal retén
13	Gasket, water pump	Dichtung	Joint	Junta
14	Gasket, thermostat housing	Dichtung	Joint	Junta
15	Radial Oil Seal, intermediate shaft	Wellendichtring, Zwischenwelle	Bague d'étanchéité, arbre intermédiaire	Anillo retén, árbol intermedio
16	Tappet Cover Material: Aluminium	Zylinderkopfhaubenmaterial: alu	Matériel de housse de la culasse: aluminium	Material culata: aluminio
17	Tappet Cover Material: Synthetic Material	Zylinderkopfhaubenmaterial: Kunststoff	Matériel de housse de la culasse: Plastiques	Material culata: Plástico
18	with heat shield	Mit Hitzeschild	Avec écran thermique	Con pantalla protectora
20	Contains BT480	Mit BT480	Contient BT480	Contiene BT480
21	Contains BX550	Mit BX550	Contient BX550	Contiene BX550
22	For pistons marked R	Mit durch R markierte Kolben	Avec pistones repères R	Con pistones marcados R
23	BF580 included	Mit BF580	Contient BF580	Contiene BF580
24	Contains JN821	Mit JN821	Contient JN821	Contiene JN821
25	Contains JM5027	Mit JM5027	Contient JM5027	Contiene JM5027
26	6mm Bolt Hole	6mm Bolzenlöcher	Boulons 6mm	Agujero tornillos 6mm
27	Oil Pan Material: Sheet Steel	Ölwanne material: Stahlblech	Matériel pour carter d'huile: tôle d'acier	Material cárter: Chapa de acero
28	to engine cylinder: 1-3	zu Motorzylinder: 1-3	sous cylindre moteur: 1-3	A cilindro de motor: 1-3
29	to engine cylinder: 4-6	zu Motorzylinder: 4-6	sous cylindre moteur: 4-6	A cilindro de motor: 4-6
31	Injection System: K-Jetronic	Einspritzanlage: K-Jetronic	Système d'injection: K-Jetronic	Sistema de inyección: K-Jetronic
32	Electronic fuel injection (Ford EEC-IV)	Elektronische Benzineinspritzung (Ford EEC-IV)	Injection électronique (Ford EEC-IV)	Inyección electrónica (Ford EEC-IV)
33	Locating dia16mm	Zentrierungsstift 16mm	Douille de centrage 16mm	Situación 16mm
34	For resurfaced cylinder head	Für bearbeiteten Zylinderkopf	Pour culasse rectifiée	Para culatas rectificadas
35	Locating dia14mm	Zentrierungsstift 14mm	Douille de centrage 14mm	Situación 14mm
36	Supplementary Article/Supplementary Info 2: With cylinder sleeve ring	Ergänzungsartikel / Ergänzende Info 2: mit Zylinderlaufbuchsenringe	Article complémentaire / Info complémentaire 2: avec deux bagues de chemises de cylindre	Artículo complementario/ Información complementaria 2: con segmentos para camisa
37	O-Ring Set, cylinder sleeve	Dichtungssatz, Zylinderlaufbuchse	Jeu de joints d'étanchéité, chemise de cylindre	Juego de juntas, camisa del cilindro
38	Radial Oil Seal, differential	Wellendichtring, Differential	Bague d'étanchéité, différentiel	Anillo retén, diferencial
39	Gasket Set, manual transmission	Dichtungssatz, Schaltgetriebe	Jeu de joints d'étanchéité, boîte de vitesse manuelle	Juego de juntas, caja de cambios
40	Supplementary Article/Supplementary Info 2: Without shaft seal	Ergänzungsartikel / Ergänzende Info 2: ohne Wellendichtring	Article complémentaire / Info complémentaire 2: sans bague d'étanchéité	Artículo complementario/ Información complementaria 2: sin anillo retención
41	Supplementary Article/Supplementary Info 2: With shaft oil seal	Ergänzungsartikel / Ergänzende Info 2: mit Wellendichtring	Article complémentaire / Info complémentaire 2: avec bague d'étanchéité	Artículo complementario/ Información complementaria 2: con anillo retención



1	Spring Seat Type	Typ gniazda sprężyny	С седлом пружины	نوع مقعد الياي
2	Oil Seal, wheel hub	Uszczelnienie olejowe, piasta kota	Сальник, ступица колеса	مانع تسريب الزيت، محور العجلة
3	Integrated seal & housing	Zintegrowane uszczelnienie z korpusem	Интегрированный в корпус сальник	مببب ومانع تسريب متكامل
4	Std bore	Otwór standardowy	Стандартное отверстие	فتحة Std
5	Oil Pan Material: Aluminium	Materiał miski olejowej - aluminium	Материал масляного поддона: алюминий	مادة وعاء الزيت: ألومنيوم
6	Oil Pan Material: Steel	Stalowa miska olejowa	Материал масляного поддона: сталь	مادة وعاء الزيت: الصلب
7	with JP067	Z JP067	с JP067	مع JP067
8	Supplementary Article/Supplementary Info 2: without oil pan gasket	Element dodatkowy/ Informacja dodatkowa 2: Bez uszczelki miski olejowej	Дополнительный элемент/ Дополнительная информация 2: без прокладки поддона картера	مادة تكميلية/معلومات تكميلية 2: بدون حشية و عاء الزيت
9	For engines with glow plugs fitted vertically	Dla silników ze świecami żarowymi montowanymi pionowo	Для двигателей с вертикальным расположением свечей накаливания	للمحركات المزودة بشمععات توهج «بوجيهات» مركبة رأسياً
11	Gasket, timing case	Uszczelka, obudowa rozrządu	Прокладка, картер ГРМ	حشية، حاوية التوقيت
12	Supplementary Article/Supplementary Info: Without crankshaft seal	Element dodatkowy/ Informacja dodatkowa 2: Bez uszczelnień wału korbowego	Дополнительный элемент/ Дополнительная информация: Без уплотнения коленвала	مادة تكميلية/معلومات تكميلية: بدون مانع تسريب عمود المرفق
13	Gasket, water pump	Uszczelka, pompa wody	Прокладка, водяной насос	حشية، مضخة ماء
14	Gasket, thermostat housing	Uszczelka, korpus termostatu	Прокладка, корпус термостата	حشية، مببب ثرموستات
15	Radial Oil Seal, intermediate shaft	Promieniowe uszczelnienie olejowe, wał łączący	Радиальный сальник, промежуточный вал	مانع تسريب قطري، عمود وسط
16	Tappet Cover Material: Aluminium	Materiał pokrywy popychaczy: Aluminium	Материал крышки толкателей: алюминий	مادة غطاء غماز: ألومنيوم
17	Tappet Cover Material: Synthetic Material	Materiał pokrywy popychaczy: Tworzywo sztuczne	Материал крышки толкателей: синтетический материал	مادة غطاء غماز: مادة صناعية
18	with heat shield	Z osłoną termiczną	С теплозащитным экраном	بواقى حراري
20	Contains BT480	Zawiera BT480	Содержит BT480	يتضمن BT480
21	Contains BX550	Zawiera BX550	Содержит BX550	يتضمن BX550
22	For pistons marked R	Dla tłoków oznaczanych R	Для поршней с меткой R	للكباسات ذات العلامة R
23	BF580 included	Dotłączone BF580	включая BF580	مع BF580
24	Contains JN821	Zawiera JN821	Содержит JN821	يتضمن JN821
25	Contains JM5027	Zawiera JM5027	Содержит JM5027	يتضمن JM5027
26	6mm Bolt Hole	Otwory pod śruby - 6 mm	6-мм болтовое отверстие	فتحة مسمار ربط 6 ملم
27	Oil Pan Material: Sheet Steel	Stalowa miska olejowa	Материал масляного поддона: листовая сталь	مادة وعاء الزيت: صفحة صلب
28	to engine cylinder: 1-3	Cylindry: 1 - 3	к цилиндрам: 1-3	إلى اسطوانة المحرك: 1-3
29	to engine cylinder: 4-6	Cylindry: 4 - 6	к цилиндрам: 4-6	إلى اسطوانة المحرك: 4-6
31	Injection System: K-Jetronic	System wtrysku paliwa: K-Jetronic	Система впрыска: K-Jetronic	نظام الحقن: K-Jetronic
32	Electronic fuel injection (Ford EEC-IV)	Elektroniczny wtrysk paliwa (Ford EEC-IV)	Электронный впрыск топлива (Ford EEC-IV)	حقن الوقود الإلكتروني (Ford EEC-IV)
33	Locating dia16mm	Otwór montażowy - 16 mm	Установочный диаметр 16 мм	مسمار تحديد موقع 16 ملم
34	For resurfaced cylinder head	Dla głowicy z ponownie obrabianą powierzchnią	Для ГБЦ с реставрированной поверхностью	لرأس الأسطوانة المعد تسويته
35	Locating dia14mm	Otwór montażowy - 14 mm	Установочный диаметр 14 мм	مسمار تحديد موقع 14 ملم
36	Supplementary Article/Supplementary Info 2: With cylinder sleeve ring	Z pierścieniem tulei cylindrowej	Дополнительный элемент/ Дополнительная информация 2: С кольцом гильзы цилиндра	مادة تكميلية/معلومات تكميلية 2: مع حلقة كم الاسطوانة
37	O-Ring Set, cylinder sleeve	Zestaw O-ringów, tuleja cylindrowa	Комплект кольцевых уплотнений, гильза цилиндра	مجموعة حلقة دائرية، كم الاسطوانة
38	Radial Oil Seal, differential	Promieniowe uszczelnienie olejowe, dyferencjał	Радиальный сальник, дифференциал	مانع تسريب قطري، تفاضلي
39	Gasket Set, manual transmission	Komplet uszczelek, mechaniczna skrzynia biegów	Комплект прокладок, механическая коробка передач	مجموعة حشية، ناقل حركة يدوي
40	Supplementary Article/Supplementary Info 2: Without shaft seal	Bez uszczelnień wału	Дополнительный элемент/ Дополнительная информация 2: Без уплотнения вала	مادة تكميلية/معلومات تكميلية 2: بدون مانع تسريب عمود
41	Supplementary Article/Supplementary Info 2: With shaft oil seal	Z uszczelnień wału	Дополнительный элемент/ Дополнительная информация 2: С сальником вала	مادة تكميلية/معلومات تكميلية 2: مع مانع تسريب عمود

TECHNICAL NOTES

Technische Hinweise • Notes techniques
Notas técnicas



42	Radial Oil Seal, manual transmission	Wellendichtring, Schaltgetriebe	Bague d'étanchéité, boîte de vitesse manuel	Anillo retén, caja de cambios
43	Gasket Set, timing case	Steuergehäusedichtungssatz	Jeu de joints de carter de distribution	Juego de juntas para cárter de distribución
44	Transmission Type: Manual Transmission, 4-speed	Getriebeart: Schaltgetriebe 4 Gang	Type de boîte de vitesses: boîte de vitesses man., à 4 vit.	Clase de caja de cambios: Manual, 4 vel.
45	Gasket, timing case cover	Steuergehäusedeckeldichtung	Joint du bouchon du carter de distribution	Junta de la tapa del cárter de distribución
46	Gasket, fuel pump	Dichtung, Kraftstoffpumpe	Joint d'étanchéité, pompe à carburant	Junta, bomba de combustible
47	Double clamp	Doppelte Befestigung	Bride double	Abrazadera doble
48	Transmission Type: Manual Transmission, 5-speed	Getriebeart: Schaltgetriebe 5 Gang	Type de boîte de vitesses: boîte de vitesses man., à 5 vit.	Clase de caja de cambios: Manual, 5 vel.
51	Oil Seal, manual transmission	Dichtung, Schaltgetriebe	Joint d'étanchéité, boîte de vitesse manuelle	Junta, caja de cambios
53	Gasket, thermostat	Dichtung	Joint	Junta
54	Seal, crankcase breather	Dichtung, Kurbelgehäuseentlüftung	Joint spi de vilebrequin	Junta, ventilación del bloque motor
56	Distributor, ignition	Zündverteiler	Distributeur d'allumage	Distribuidor de encendido
57	Sealant	Dichtmasse	Pâte à joints	Sellante
60	Not included in sets	Not included in sets	Not included in sets	Not included in sets
61	Transmission Type: BE03	Getriebeart: BE03	Type de boîte de vitesses: BE03	Clase de caja de cambios: BE03
63	BF320 included	BF320 included	BF320 included	BF320 included
64	BN320 included	BN320 included	BN320 included	BN320 included
66	Transmission Type: 4HP18	Getriebeart: 4HP18	Type de boîte de vitesses: 4HP18	Clase de caja de cambios: 4HP18
67	Transmission Type: BE3/5	Getriebeart: BE3/5	Type de boîte de vitesses: BE3/5	Clase de caja de cambios: BE3/5
68	->10/94: Piston Protrusion Above 0.81mm 10/94->: Piston Protrusion 0.87 to 0.91mm	->10/94: Überstand des Kolbens über 0.81mm 10/94->: Überstand des Kolbens 0.87 bis 0.91mm	->10/94: Dépassement de piston au-dessus de 0.81mm 10/94->: Dépassement de piston 0.87 à 0.91mm	->10/94: Protuberancia Pistón Mayor Que 0.81mm 10/94->: Protuberancia pistón de 0,87 a 0,91mm
69	Transmission Type: MG5TU	Getriebeart: MG5TU	Type de boîte de vitesses: MG5TU	Clase de caja de cambios: MG5TU
70	Radial Oil Seal, oil pump	Wellendichtring, Ölpumpe	Bague d'étanchéité, pompe à huile	Anillo de retención,
71	2 Locating holes of 13mm	Merkierungskerbe 13mm	Détrompeur 13mm	Muesca de ubicación 13mm
72	Gasket, charger	Laderdichtung	Joint de surcompresseur	Junta de compresor
73	Charge Type: Turbo Intercooler	Aufladungsart: Turbo/Intercooler	Type de chargement: turbo/refroidissement d'air de suralimentation	Tipo de sobrealimentación:
78	Outer Diameter 1 [mm]: 152	Aussendurchmesser 1 [mm]: 152	Diamètre extérieur 1 [mm]: 152	Diámetro exterior 1[mm]: 152
79	8.5mm Centering Diameter	Zentrierungsdurchmesser 8,5mm	Douille de centrage 8,5mm	Diámetro centrador 8,5mm
80	6.5mm Centering Diameter	Zentrierungsdurchmesser 6,5mm	Douille de centrage 6,5mm	Diámetro centrador 6,5mm
81	Seal, oil pump	Dichtung	Joint	Junta
82	Rocker cover studs with shoulder 6.5mm	Kippbeldeckel mit Schulter 6,5mm	Clou de couvre-culbuteur 6,5mm	Junta tapa válvulas con paso de tornillos de 6,5mm
83	Rocker cover studs with shoulder 8.5mm	Kippbeldeckel mit Schulter 8,5mm	Clou de couvre-culbuteur 8,5mm	Junta tapa válvulas con paso de tornillos de 8,5mm
85	Outer Diameter 1 [mm]: 153	Aussendurchmesser 1 [mm]: 153	Diamètre extérieur 1 [mm]: 153	Diámetro exterior 1[mm]: 153
86	Seal, oil filter housing	Dichtung, Ölfiltergehäuse	Joint d'étanchéité, boîtier de filtre à huile	Junta, carcasa del filtro de aceite
87	to engine cylinder: Cyl 1-3	zu Motorzylinder: Cyl 1-3	sous cylindre moteur: Cyl 1-3	A cilindro de motor: Cyl 1-3
88	to engine cylinder: Cyl 4-6	zu Motorzylinder: Cyl 4-6	sous cylindre moteur: Cyl 4-6	A cilindro de motor: Cyl 4-6
89	Without JN581	Ohne JN581	Sans JN581	Excluido JN581
91	Gasket, carburettor flange	Dichtung, Vergaserflansch	Joint d'étanchéité, bride de carburateur	Junta, brida de carburador
93	With JJ517	Mit JJ517	Avec JJ517	Con JJ517
94	Sealing compound	Dichtmasse	Pâte à joint	Pasta para sellar
95	It includes BW720	Mit BW720	BW720 inclus	Contiene BW720
96	With BW720 and JM5002	Mit BW720 + JM5002	Avec BW720 et JM5002	Con BW720 y JM5002
97	With BX720 and JM5002	Mit BX720 + JM5002	Avec BX720 et JM5002	Con BX720 + JM5002
98	contains AA5420	Mit AA5420	Contient AA5420	Contiene AA5420
99	JA5035 and JD580 included	beinhaltet JA5035 + JD580	JA5035 et JD580 inclus	Incluye JA5035 y JD580
100	Contains JJ298 and JJ398	Contains JJ298 and JJ398	Contains JJ298 and JJ398	Contains JJ298 and JJ398
101	With BW710 and JH5002	Mit BW710 + JH5002	Avec BW710 et JH5002	Con BW710 y JH5002



42	Radial Oil Seal, manual transmission	Promieniowe uszczelnienie olejowe, mechaniczna skrzynia biegów	Радиальный сальник, механическая коробка передач	مانع تسريب قطري، ناقل حركة يدوي
43	Gasket Set, timing case	Komplet uszczelek, obudowa rozrządu	Комплект прокладок, картер ГРМ	مجموعة حشبية، حاوية التوقيت
44	Transmission Type: Manual Transmission, 4-speed	Typ skrzyni biegów: skrzynia ręczna 4-biegowa	Тип коробки передач: Механическая коробка передач, 4-ступенчатая	نوع ناقل الحركة: ناقل حركة يدوي، رباعي السرعات
45	Gasket, timing case cover	Uszczelka, pokrywa rozrządu	Прокладка, крышка картера ГРМ	حشبية، غطاء حاوية التوقيت
46	Gasket, fuel pump	Uszczelka, pompa paliwa	Прокладка, топливный насос	حشبية، مضخة وقود
47	Double clamp	Podwójny zacisk	Двойной зажим	مشبك مزدوج
48	Transmission Type: Manual Transmission, 5-speed	Typ skrzyni biegów: skrzynia ręczna 5-biegowa	Тип коробки передач: Механическая коробка передач, 5-ступенчатая	نوع ناقل الحركة: ناقل حركة يدوي، خماسي السرعات
51	Oil Seal, manual transmission	Uszczelnienie olejowe, mechaniczna skrzynia biegów	Сальник, механическая коробка передач	مانع تسريب زيت، ناقل حركة يدوي
53	Gasket, thermostat	Uszczelka, termostat	Прокладка, термостат	حشبية، ثرموستات
54	Seal, crankcase breather	Uszczelnienie, odpowietrzenie skrzyni korbowej	Уплотнение, сапун картера	مانع تسريب، وحدة تنقيس عمود المرفق
56	Distributor, ignition	Dystrybutor, zapłon	Распределитель, зажигание	الموزع، الإشعال
57	Sealant	Uszczelniacz	Герметик	مانع تسريب
60	Not included in sets	Nie zawarte w komplecie/kompletach	Не входит в комплекты	غير مرفق مع كل المجموعات
61	Transmission Type: BE03	Skrzynia biegów typ BE03	Тип коробки передач: BE03	نوع ناقل الحركة: BE03
63	BF320 included	Zawiera BF320	включая BF320	مع BF320
64	BN320 included	Zawiera BN320	включая BN320	مع BN320
66	Transmission Type: 4HP18	Skrzynia biegów typ 4HP18	Тип коробки передач: 4HP18	نوع ناقل الحركة: 4HP18
67	Transmission Type: BE3/5	Skrzynia biegów typ BE3/5	Тип коробки передач: BE3/5	نوع ناقل الحركة: BE3/5
68	->10/94: Piston Protrusion Above 0.81mm 10/94->: Piston Protrusion 0.87 to 0.91mm	->10/94: Wysunięcie tłoka ponad 0,81 mm lub 10/94->: Wysunięcie tłoka od 0,87 do 0,91 mm	->10/94: выступ поршня более 0,81 мм 10/94->: Выступ поршня 0,87-0,91 мм	10/94->: بروز الكباس فوق 0.81 ملم 10/94->: بروز الكباس فوق 0.87 إلى 0.91 ملم
69	Transmission Type: MG5TU	Skrzynia biegów typ MG5TU	Тип коробки передач: MG5TU	نوع ناقل الحركة: MG5TU
70	Radial Oil Seal, oil pump	Promieniowe uszczelnienie olejowe, pompa oleju	Радиальный сальник, масляный насос	مانع تسريب قطري، مضخة زيت
71	2 Locating holes of 13mm	Dwa otwory montażowe - 13mm	2 установочных отверстия 13 мм	فتحتا تحديد موقع سعة 13 ملم
72	Gasket, charger	Uszczelka, doładowanie	Прокладка, нагнетатель	حشبية، شاحن
73	Charge Type: Turbo Intercooler	Rodzaj doładowania: Turbo intercooler	Тип нагнетания: Интеркулер турбокомпрессора	نوع الشحنة: مبرد داخلي للتيربو
78	Outer Diameter 1 [mm]: 152	Średnica zewnętrzna 152 mm	Наружный диаметр 1 [мм]: 152	قطر خارجي 1 [ملم]: 152
79	8.5mm Centering Diameter	Średnica centrująca 8,5 mm	Базовый диаметр 8,5 мм	قطر توسيط 8.5 ملم
80	6.5mm Centering Diameter	Średnica centrująca 6,5 mm	Базовый диаметр 6,5 мм	قطر توسيط 6.5 ملم
81	Seal, oil pump	Uszczelnienie, pompa oleju	Уплотнение, масляный насос	مانع تسريب، مضخة الزيت
82	Rocker cover studs with shoulder 6.5mm	Śruby mocujące pokrywę dźwigni zaworowych z wypustem 6,5 mm	Шпильки крышки коромысла с выступом 6,5 мм	مسامير غطاء الرذاد بكتف 6.5 ملم
83	Rocker cover studs with shoulder 8.5mm	Śruby mocujące pokrywę dźwigni zaworowych z wypustem 8,5 mm	Шпильки крышки коромысла с выступом 8,5 мм	مسامير غطاء الرذاد بكتف 8.5 ملم
85	Outer Diameter 1 [mm]: 153	Średnica zewnętrzna 153 mm	Наружный диаметр 1 [мм]: 153	قطر خارجي 1 [ملم]: 153
86	Seal, oil filter housing	Uszczelnienie, korpus filtra oleju	Уплотнение, корпус масляного фильтра	مانع تسريب، مبيت فلتر الزيت
87	to engine cylinder: Cyl. 1-3	do cylindrów: Cylindry 1 - 3	к цилиндрам: Цилиндры 1-3	إلى اسطوانة المحرك: اسطوانة 1-3
88	to engine cylinder: Cyl. 4-6	do cylindrów: Cylindry 4 - 6	к цилиндрам: Цилиндры 4-6	إلى اسطوانة المحرك: اسطوانة 4-6
89	Without JN581	Bez JN581	Без JN581	بدون JN581
91	Gasket, carburettor flange	Uszczelka, kotłnierz gaźnika	Прокладка, фланец карбюратора	حشبية، شفة المكرين
93	With JJ517	Z JJ517	С JJ517	مع JJ517
94	Sealing compound	Uszczelnienie złożone	Герметизирующий состав	مركب مانع التسريب
95	It includes BW720	Zawiera BW720	Включает BW720	يتضمن BW720
96	With BW720 and JM5002	Z BW720 i JM5002	С BW720 i JM5002	مع BW720 و JM5002
97	With BX720 and JM5002	Z BX720 i JM5002	С BX720 i JM5002	مع BX720 و JM5002
98	contains AA5420	Zawiera AA5420	содержит AA5420	يتضمن AA5420
99	JA5035 and JD580 included	Zawiera JA5035 i JD580	JA5035 i JD580 входят в комплект	يتضمن JA5035 و JD580 متضمنان
100	Contains JJ298 and JJ398	Zawiera JJ298 i JJ398	Содержит JJ298 i JJ398	يتضمن JJ298 و JJ398
101	With BW710 and JH5002	Z BW710 i JH5002	С BW710 i JH5002	مع BW710 و JH5002

TECHNICAL NOTES

Technische Hinweise • Notes techniques
Notas técnicas



102	4 x PB248 required	4 X PB248 zusätzlich	A ajouter 4 x PB248	Necesarios 4 x PB248
105	With JP068	Mit JP068	JP068 inclus	Con JP068
106	With JA5036 and JD581	beinhaltet JA5036 + JD581	Avec JA5036 et JD581	Con JA5036 y JD581
108	With JN807 and JN808	Mit JN807 + JN808	Avec JN807 et JN808	Con JN807 y JN808
109	With JN462 and JN594	Mit JN462 und JN594	Avec JN462 et JN594	Con JN462 y JN594
110	Without JJ519	Ohne JJ519	Sans JJ519	Excluido JJ519
111	includes JN594 + JN956	includes JN594 + JN956	includes JN594 + JN956	includes JN594 + JN956
112	Locating hole 13mm	Markierungskerbe 13mm	Fori di centraggio 13mm	Muesca de ubicación 13mm
113	DC373 & GH857 included	beinhaltet DC373 & GH857	DC373 & GH857 inclus	Incluye DC373 y GH857
114	CN301 & FN308 included	beinhaltet CN301 & FN308	CN301 & FN308 inclus	Incluye CN301 y FN308
115	contains JM5023 + KM5024	Mit JM5023 + KM5024	Contient JM5023 + KM5024	Contiene JM5023 + KM5024
116	with compression limiters	Mit Abstandshaltern	Avec cale de limite d'écrasement	Con límite de torsión
117	Inner Diameter [mm]: 9	Innendurchmesser [mm]: 9	Diamètre intérieur [mm]: 9	Diámetro interior [mm]: 9
118	Outer Diameter 1 [mm]: 163	Aussendurchmesser 1 [mm]: 163	Diamètre extérieur 1 [mm]: 163	Diámetro exterior 1[mm]: 163
119	Seal, spark plug stem	Dichtung, Kerzenschaft	Joint d'étanchéité, tige de bougie	Junta, varilla de las bujías
120	Rod gear change	Stangegangwechsel	Seulement changement de manchon d'engrangement	Cambio engranaje biela
121	Copper faced CHG	Zylinderkopfdichtung in kupfer/Weichstoff	Joint de culasse fibre et cuivre	Junta colata en cobre/fibre
122	CHG with oil feed grommet	Zylinderkopfdichtung mit Loch für Öleinfassung	Joint de culasse avec insert pour l'huile	Junta de culata con paso de aceite con arandela
123	CHG without oil feed grommet	Zylinderkopfdichtung ohne Loch für Öleinfassung	Joint de culasse sans insert pour l'huile	Junta de culata con paso de aceite sin arandela
124	11 bolt timing cover	Steuerriemendeckel mit 11 Bolzen	Couvercle de distribution 11 boulons	Cubierta distribución 11 pernos
125	10 bolt timing cover	Steuerriemendeckel mit 10 Bolzen	Couvercle de distribution 10 boulons	Cubierta distribución 10 pernos
126	Cylinder side cover joint	Cylinder side cover joint	Cylinder side cover joint	Cylinder side cover joint
127	7mm Bolt Holes	7mm Bolzenlöcher	Boulons 7mm	7mm Bolt Holes
128	9mm Bolt Holes	9mm Bolzenlöcher	Boulons 9mm	Agujero tornillos 9mm
129	Contains 2 x JJ120	Mit 2 x JJ120	Contient 2 x JJ120	Contiene 2 x JJ120
130	Drive Type: All-wheel Drive	Antriebsart: Allrad	Mode de traction: traction intégrale	Tipo de tracción: A las 4 ruedas
131	Drive Type: Rear Wheel Drive	Antriebsart: Heckantrieb	Mode de traction: propulsion	Tipo de tracción: Tracción trasera
133	With heat shield	Mit Hitzeschutzschild	Avec écran thermique	Con protector térmico
134	to engine cylinder: 1,3,4	zu Motorzylinder: 1,3,4	sous cylindre moteur: 1,3,4	A cilindro de motor: 1,3,4
135	Engine Block Material: Cast Steel	Motorblockmaterial: Stahlguß	Matériel pour bloc-moteur: fonte	Material bloque: Acero fundido
136	Engine Block Material: Aluminium	Motorblockmaterial: alu	Matériel pour bloc-moteur: aluminium	Material bloque: aluminio
137	to engine cylinder: 1,2,5-8	zu Motorzylinder: 1,2,5-8	sous cylindre moteur: 1,2,5-8	A cilindro de motor: 1,2,5-8
138	to engine cylinder: 5 - 8	zu Motorzylinder: 5 - 8	sous cylindre moteur: 5 - 8	A cilindro de motor: 5 - 8
139	to engine cylinder: 1 - 4	zu Motorzylinder: 1 - 4	sous cylindre moteur: 1 - 4	A cilindro de motor: 1 - 4
140	to engine cylinder: 1 - 4	zu Motorzylinder: 1 - 4	sous cylindre moteur: 1 - 4	A cilindro de motor: 1 - 4
141	Shaft Oil Seal, steering rack	Wellendichtring, Lenkgetriebe	bague d'étanchéité système S.P.I., boîte de direction	Anillo retención, mecanismo dirección
144	Radial Oil Seal, transfer case	Wellendichtring, Verteilergetriebe	Bague d'étanchéité, casier de transfert	Anillo retén, engranaje distribuidor
146	Transmission Type: ME5TU	Getriebeart: ME5TU	Type de boîte de vitesses: ME5TU	Clase de caja de cambios: ME5TU
147	Includes JH5002, JJ519	beinhaltet JH5002, JJ519	JH5002 & JJ519 inclus	Incluye JH5002, JJ519
148	With oil retainer	Mit Ölfangblech	Avec retour d'huile	Con arandela de aceite
149	Exhaust pipe to muffler	Auspuffrohr zu Schalldämpfer	Bride d'échappement vers silencieux	Tubo de escape a silenciador
152	Outer Diameter 1 [mm]: 66	Aussendurchmesser 1 [mm]: 66	Diamètre extérieur 1 [mm]: 66	Diámetro exterior 1[mm]: 66
153	Contains BP520	Contains BP520	Contains BP520	Contains BP520
154	Contains BP030	Mit BP030	Contient BP030	Contiene BP030
155	Gasket, heat exchanger	Dichtung, Wärmetauscher	Joint d'étanchéité, échangeur de chaleur	Junta, intercambiador de calor
156	Valve Tappet Support	Ventilstoesselsteuerung	Support de poussoir	Soporte tapa válvulas
157	Contains AY470	Mit AY470	Contient AY470	Contiene AY470
158	Contains JJ449	Mit JJ449	Contient JJ449	Contiene JJ449
159	Front Left	Vorne links	Avant gauche	Delantero izquierda
160	Seal, oil filter	Dichtung, Ölfilter	Joint d'étanchéité, filtre à huile	Junta, filtro de aceite
161	Locating hole 10mm	Markierungskerbe 10mm	Détrompeur 10mm	Muesca de ubicación 10mm



102	4 x PB248 required	Wymagane 4 x PB248	Требуется 4 x PB248	مطلوب 4 x PB248
105	With JP068	Z JP068	С JP068	مع JP068
106	With JA5036 and JD581	Z JA5036 i JD581	С JA5036 и JD581	مع JA5036 و JD581
108	With JN807 and JN808	Z JN807 i JN808	С JN807 и JN808	مع JN808 و JN807
109	With JN462 and JN594	Z JN462 i JN594	С JN462 и JN594	مع JN594 و JN462
110	Without JJ519	Bez JJ519	Без JJ519	بدون JJ519
111	includes JN594 + JN956	Zawiera JN594 + JN956	включает JN594 + JN956	يضمّن JN594 + JN956
112	Locating hole 13mm	Otwór montażowy 13 mm	Установочное отверстие 13 мм	فتحة تحديد موقع سعة 13 ملم
113	DC373 & GH857 included	Zawiera DC373 & GH857	DC373 и GH857 включены в комплект	متضمنين DC373 و GH857
114	CN301 & FN308 included	Zawiera CN301 & FN308	CN301 и FN308 включены в комплект	متضمنين FN308 و CN301
115	contains JM5023 + KM5024	Zawiera JM5023 + KM5024	содержит JM5023 + KM5024	يضمّن JM5023 + KM5024
116	with compression limiters	Z ogranicznikiem kompresji	с ограничителями сжатия	مع محددات انضغاط
117	Inner Diameter [mm]: 9	Średnica wewnętrzna [mm]: 9	Внутренний диаметр [мм]: 9	قطر داخلي [ملم]: 9
118	Outer Diameter 1 [mm]: 163	Średnica zewnętrzna 163 mm	Наружный диаметр 1 [мм]: 163	قطر خارجي 1 [ملم]: 163
119	Seal, spark plug stem	Uszczelnienie, trzon świecy iskrowych	Уплотнение, стержень свечи зажигания	مانع تسريب، جذر سدادة الشمعة
120	Rod gear change	Drążek mechanizmu zmiany biegów	Стержень рычага переключения передач	تغيير ترس القضيب
121	Copper faced CHG	Uszczelka podgłowicowa z powierzchnią miedzianą	CHG с медной облицовкой	تغيير السطح النحاسي
122	CHG with oil feed grommet	CHG z otworem na kanał olejowy	CHG с втулкой подачи масла	CHG بعروة تغذية الزيت
123	CHG without oil feed grommet	CHG bez otworu na kanał olejowy	CHG без втулки подачи масла	CHG بدون عروة تغذية الزيت
124	11 bolt timing cover	Pokrywa rozrządu - 11 śrub	11-болтовая крышка ГРМ	غطاء توقيت مسمار الربط 11
125	10 bolt timing cover	Pokrywa rozrządu - 10 śrub	10-болтовая крышка ГРМ	غطاء توقيت مسمار الربط 10
126	Cylinder side cover joint	Połączenie pokrywy od strony cylindra	Стык боковой крышки блока цилиндров	وصلة غطاء جانب الاسطوانة
127	7mm Bolt Holes	Otwory po śrubę 7 mm	7-мм болтовые отверстия	فتحات مسامير 7 ملم
128	9mm Bolt Holes	Otwory po śrubę 9 mm	9-мм болтовые отверстия	فتحات مسامير 9 ملم
129	Contains 2 x JJ120	Zawiera 2 x JJ120	Содержит 2 x JJ120	يتمضمّن 2 x JJ120
130	Drive Type: All-wheel Drive	Rodzaj napędu: napęd na wszystkie koła	Тип привода: Полный привод	نوع الدفع: دفع من كل العجلات
131	Drive Type: Rear Wheel Drive	Rodzaj napędu: napęd na koła tyłne	Тип привода: Задний привод	نوع الدفع: دفع العجلة الخلفية
133	With heat shield	Z osłoną termiczną	С теплозащитным экраном	بواقي حراري
134	to engine cylinder: 1,3,4	Cylindry: 1, 3, 4	к цилиндрам: 1,3,4	إلى اسطوانة المحرك: 1,3,4
135	Engine Block Material: Cast Steel	Materiał bloku cylindrów: staliwo	Материал блока цилиндров: литая сталь	مادة كتلة المحرك: صلب مصبوب
136	Engine Block Material: Aluminium	Materiał bloku cylindrów: aluminium	Материал блока цилиндров: алюминий	مادة كتلة المحرك: ألومنيوم
137	to engine cylinder: 1,2,5-8	do cylindrów: 1, 2, 5-8	к цилиндрам: 1,2,5-8	إلى اسطوانة المحرك: 1,2,5-8
138	to engine cylinder: 5 - 8	do cylindrów: 5 - 8	к цилиндрам: 5 - 8	إلى اسطوانة المحرك: 5 - 8
139	to engine cylinder: 1 - 4	do cylindrów: 1 - 4	к цилиндрам: 1 - 4	إلى اسطوانة المحرك: 1 - 4
140	to engine cylinder: 1 - 4	do cylindrów: 1 - 4	к цилиндрам: 1 - 4	إلى اسطوانة المحرك: 1 - 4
141	Shaft Oil Seal, steering rack	Olejowe uszczelnienie wałka, przekładnia kierownicza	Уплотнение вала, рулевая рейка	مانع تسريب زيت العمود، رف التوجيه
144	Radial Oil Seal, transfer case	Promieniowe uszczelnienie olejowe, obudowa przekładni	Радиальный сальник, раздаточная коробка	مانع تسريب قطري، حقيبة نقل
146	Transmission Type: ME5TU	Skrzynia biegów typu ME5TU	Тип коробки передач: ME5TU	نوع ناقل الحركة: ME5TU
147	Includes JH5002, JJ519	Zawiera JH5002, JJ519	Включает JH5002, JJ519	يضمّن JH5002، JJ519
148	With oil retainer	Ze zbiornikiem na olej	С маслосъёмником	بحاجز الزيت
149	Exhaust pipe to muffler	Rura wydechowa do tłumika	Выпускная труба к глушителю	أنبوب عادم إلى كاتم الصوت
152	Outer Diameter 1 [mm]: 66	Średnica zewnętrzna 66 mm	Наружный диаметр 1 [мм]: 66	قطر خارجي 1 [ملم]: 66
153	Contains BP520	Zawiera BP520	Содержит BP520	يضمّن BP520
154	Contains BP030	Zawiera BP030	Содержит BP030	يضمّن BP030
155	Gasket, heat exchanger	Uszczelka, wymiennik ciepła	Прокладка, теплообменник	حشية، مبادل حرارة
156	Valve Tappet Support	Wspornik popychacza zaworu	Опора толкателя клапана	دعامة غماز الصمام
157	Contains AY470	Zawiera AY470	Содержит AY470	يضمّن AY470
158	Contains JJ449	Zawiera JJ449	Содержит JJ449	يضمّن JJ449
159	Front Left	Przód lewy/a	Передний левый	أمامي أيسر
160	Seal, oil filter	Uszczelnienie, filtr olehu	Уплотнение, масляный фильтр	مانع تسريب، فلتر الزيت
161	Locating hole 10mm	Otwór montażowy 10 mm	Установочное отверстие 10 мм	فتحة تحديد موقع سعة 10 ملم

TECHNICAL NOTES

Technische Hinweise • Notes techniques
Notas técnicas



162	With JM5181	Mit JM5181	Avec JM5181	Con JM5181
163	With JM5019	Mit JM5019	Avec JM5019	Con JM5019
164	Water Pump Body	Wasserpumpenkörperdichtung	Joint de pompe à eau	Cuerpo, bomba de agua
165	Between upper and lower Cylinder Head	Zwischen höherem und tieferem (oberem und unterem) Krümmer	Entre joints supérieur et inférieur	Entre el colector superior y inferior
167	Without JH5002	Ohne JH5002	À l'exclusion de JH5002	Excluido JH5002
168	0,20mm Oversize	Übermaß Dicke +0,20mm	Surépaisseur +0,20mm	Sobre medida espesor + 0,20 mm
169	With JM5018	beinhaltet JM5018	Avec JM5018	Con JM5018
170	With BV940	Mit BV940	Avec BV940	Con BV940
171	With BP280	Mit BP280	With BP280	With BP280
173	Not for country-spec. model: Germany	nicht für Länderausführung: Deutschland	pas pour version pays: Allemagne	no modelo país: Alemania
174	Piston Protrusion 0,56 to 0,67mm	Überstand des Kolbens 0,56 bis 0,67mm	Dépassement de piston 0,56 à 0,67mm	Protuberancia pistón de 0,56 a 0,67mm
175	Piston protrusion 0,68 to 0,71mm	Überstand des Kolbens 0,68 bis 0,71mm	Dépassement de piston 0,68 à 0,71mm	Protuberancia pistón de 0,68 a 0,71mm
176	Piston protrusion 0,72 to 0,75mm	Überstand des Kolbens 0,72 bis 0,75mm	Dépassement de piston 0,72 à 0,75mm	Protuberancia pistón de 0,72 a 0,75mm
177	Piston Protrusion 0,76 to 0,79mm	Überstand des Kolbens 0,76 bis 0,79mm	Dépassement de piston 0,76 à 0,79mm	Protuberancia pistón de 0,76 a 0,79mm
178	Piston protrusion 0,80 to 0,83mm	Überstand des Kolbens 0,80 bis 0,83mm	Dépassement de piston 0,80 à 0,83mm	Protuberancia pistón de 0,80 a 0,83mm
181	For Engines with Steel Oil Pan	Ölwanenmaterial: Stahl	Matériel pour carter d'huile: acier	Material cárter: Acero
183	For engines with 3 bearing crankshafts	Für Motoren mit 3-fach gelagerten Kurbelwellen	Pour moteur avec vilebrequin 3 paliers	Para motores con cigüeñales de 3 cojinetes
184	Oil seal kit	Öldichtungssatz	Jeu de bague d'étanchéité	Juego de retén de aceite
185	For engines with 5 bearing crankshafts	Für Motoren mit 5-fach gelagerten Kurbelwellen	Pour moteurs avec vilebrequins 5 paliers	Para motores con 5 soportes de fijación de cigüeñales
186	Inner	Innen	Intérieur	Interior
187	Outer	Aussen	Extérieur	Exterior
188	Alternative material	Alternativmaterial	Matériau en option	Material alternativo
190	HeadSaver®	HeadSaver®	HeadSaver®	HeadSaver®
192	For plastic manifolds only	Für Plastikhaube	Seulement pour collecteur en plastique	Solo para colectores de plástico
193	"O" ring type valve stem seals	O-rings	Type joint torique	Tipo junta tórica
195	Vehicle Equipment: for vehicles with ride height adjustment	Fahrzeugausstattung: für Fahrzeuge mit Niveauregulierung	Équipement véhicule: pour véhicule avec correcteur d'assiette	Equipamiento de vehículo: para vehículos con regulación de nivel
196	Vehicle Equipment: For vehicles without ride height adjustment	Fahrzeugausstattung: für Fahrzeuge ohne Niveauregulierung	Équipement véhicule: pour véhicule sans réglage de niveau	Equipamiento de vehículo: para vehículos sin regulación de nivel
197	Vehicle Equipment: For vehicles with automatic transmission	Fahrzeugausstattung: für Fahrzeuge mit Automatikgetriebe	Équipement véhicule: pour véhicule avec boîte de vitesses automatique	Equipamiento de vehículo: para vehículos con caja automática
198	Vehicle Equipment: For vehicles with manual transmission	Fahrzeugausstattung: für Fahrzeuge mit Schaltgetriebe	Équipement véhicule: pour véhicules avec boîte de vitesses manuelle	Equipamiento de vehículo: para vehículos con caja manual
199	Without level control system	Ohne Niveauregulierung	Sans mise à niveau auto	Sin sistema de control de nivel
201	8mm Bolt	8mm Bolzenlöcher	Boulons 8mm	Agujero tornillos 8mm
202	Jet	Strahl	Gicleur	Jet
204	For engines with balance shafts	Motor mit der Ausgleichswelle	Moteur avec arbre de compensation	Motor con arbol balancin
205	Not for country-spec. model: Great Britain	nicht für Länderausführung: Großbritannien	pas pour version pays: Grande-Bretagne	no modelo país: Gran Bretaña
207	Twin carburettor models	Zweivergasermodele	Modèles avec carburateur double corps.	Modelos de dos carburadores.
208	Radial Oil Seal, flywheel	Dichtung, Schwungrad	Joint d'étanchéité, volant moteur	Junta, Volante motor
209	Bolt / Nut Version: With plain washer	Schrauben-/Mutterausführung: mit Unterlegscheibe	Type d'écrou: avec rondelle de calage	Modelo de tornillo/tuerca: con arandela
210	Vehicle Equipment: For vehicles with air conditioning	Fahrzeugausstattung: für Fahrzeuge mit Klimaanlage	Équipement véhicule: pour véhicule avec système de climatisation	Equipamiento de vehículo: para vehículos con climatizador



162	With JM5181	Z JM5181	C JM5181	JM5181 مع
163	With JM5019	Z JM5019	C JM5019	JM5019 مع
164	Water Pump Body	Korpus pompy wody	Корпус водяного насоса	جسم مضخة الماء
165	Between upper and lower Cylinder Head	Pomiędzy górną i dolną głowicą cylindra	Между верхней и нижней головкой блока цилиндров	بين رأس الاسطوانة العلوي والسفلي
167	Without JH5002	Bez JH5002	Без JH5002	بدون JH5002
168	0,20mm Oversize	Nadwymiar 0,20 mm	0,20 мм (ремонтный размер)	حجم زائد 0.20 ملم
169	With JM5018	Z JM5018	C JM5018	مع JM5018
170	With BV940	Z BV940	C BV940	مع BV940
171	With BP280	Z BP280	C BP280	مع BP280
173	Not for country-spec. model: Germany	Nie dla modelu specjalnego dla kraju: Niemcy	Кроме моделей, предназначенных для сбыта в следующих странах: Германия	ليس لمواصفات البلد الطراز : ألمانيا
174	Piston Protrusion 0,56 to 0,67mm	Wysunięcie tłoka od 0,56 do 0,67 mm	Выступ поршня 0,56-0,67 мм	بروز الكباس 0.56 إلى 0.67 ملم
175	Piston protrusion 0,68 to 0,71mm	Wysunięcie tłoka od 0,68 do 0,71 mm	Выступ поршня 0,68-0,71 мм	بروز الكباس 0.68 إلى 0.71 ملم
176	Piston protrusion 0,72 to 0,75mm	Wysunięcie tłoka od 0,72 do 0,75 mm	Выступ поршня 0,72-0,75 мм	بروز الكباس 0.72 إلى 0.75 ملم
177	Piston Protrusion 0,76 to 0,79mm	Wysunięcie tłoka od 0,76 do 0,79 mm	Выступ поршня 0,76-0,79 мм	بروز الكباس 0.76 إلى 0.79 ملم
178	Piston protrusion 0,80 to 0,83mm	Wysunięcie tłoka od 0,80 do 0,83 mm	Выступ поршня 0,80-0,83 мм	بروز الكباس 0.80 إلى 0.83 ملم
181	For Engines with Steel Oil Pan	Dla silników ze stalową miską olejową	Для двигателей со стальным поддоном картера	للمحركات المزودة بعلبة زيت صلب
183	For engines with 3 bearing crankshafts	Dla silników z 3 łożyskami głównymi wału korbowego	Для двигателей с трехопорными коленвалами	للمحركات المزودة بأعمدة كرنك بثلاثة محامل
184	Oil seal kit	Zestaw olejowych uszcznień	Комплект сальников	مجموعة مانع تسريب الزيت
185	For engines with 5 bearing crankshafts	Dla silników z 5 łożyskami głównymi wału korbowego	Для двигателей с пятиопорными коленвалами	للمحركات المزودة بأعمدة كرنك بخمسة محامل
186	Inner	Wewnętrzny	Внутренний	داخلي
187	Outer	Zewnętrzny	Наружный	خارجي
188	Alternative material	Materiał alternatywny	Альтернативный материал	مادة بديلة
190	HeadSaver®	HeadSaver®	HeadSaver®	HeadSaver®
192	For plastic manifolds only	Tylko dla kolektorów z tworzyw sztucznych	Только для пластиковых коллекторов	للمجامع البلاستيكية فقط
193	“O” ring type valve stem seals	Uszczelnienie trzonka zaworu typu O-ring	Кольцевые уплотнения штока клапана	موانع تسريب جذر صمام من نوع حلقة «O»
195	Vehicle Equipment: for vehicles with ride height adjustment	Dla samochodów z regulacją prześwitu podwozia	Оборудование автомобиля: для автомобилей с регулировкой высоты подвески	معدة المركبة: للمركبات التي يمكن ضبط ارتفاع الركوب بها
196	Vehicle Equipment: For vehicles without ride height adjustment	Dla samochodów bez regulacji prześwitu podwozia	Оборудование автомобиля: Для автомобилей без регулировки высоты подвески	معدة المركبة: للمركبات التي لا يمكن ضبط ارتفاع الركوب بها
197	Vehicle Equipment: For vehicles with automatic transmission	Dla samochodów z automatyczną skrzynią biegów	Оборудование автомобиля: Для автомобилей с автоматической коробкой передач	معدة المركبة: للمركبات التي تحتوي على ناقل حركة تلقائي
198	Vehicle Equipment: For vehicles with manual transmission	Dla samochodów z mechaniczną skrzynią biegów	Оборудование автомобиля: Для автомобилей с механической коробкой передач	معدة المركبة: للمركبات التي تحتوي على ناقل حركة يدوي
199	Without level control system	Bez systemu kontroli poziomu	Без системы управления уровнем	بدون نظام تحكم في المستوى
201	8mm Bolt	Śruba 8 mm	Болт 8 мм	مسمار ربط 8 ملم
202	Jet	Rozpylacz	Форсунка	Jet
204	For engines with balance shafts	Dla silników z wałkiem wyrównującym	Для двигателей с уравнивающим валом	للمحركات المزودة بأعمدة توازن
205	Not for country-spec. model: Great Britain	Nie dla modelu specjalnego dla kraju: Wielka Brytania	Кроме моделей, предназначенных для сбыта в следующих странах: Великобритания	ليس لمواصفات البلد الطراز : بريطانيا العظمى
207	Twin carburettor models	Modele podwójnymi gaźnikami	Двухкарбюраторные модели	الطراز ذات المكربن المزدوج
208	Radial Oil Seal, flywheel	Olejowe uszczelnienie promieniowe, koło zamachowe	Радиальный сальник, маховик	مانع تسريب قطري، تفاضلي
209	Bolt / Nut Version: With plain washer	Wersja śruba/ nakretka: z podkładką	Тип болта/гайки: С плоской шайбой	نسخة مسمار الربط/الصامولة مع وردة عادية
210	Vehicle Equipment: For vehicles with air conditioning	Dla samochodów z klimatyzacją	Оборудование автомобиля: Для автомобилей с кондиционером	معدة المركبة: للمركبات التي تحتوي على مكيف هواء

TECHNICAL NOTES

Technische Hinweise • Notes techniques
Notas técnicas



211	Vehicle Equipment: for vehicles without air conditioner	Fahrzeugausstattung: für Fahrzeuge ohne Klimaanlage	Équipement véhicule: pour véhicule sans système de climatisation	Equipamiento de vehículo: para vehículos sin aire acondicionado
212	For engines with two piece oil pan	Für motoren mit 2 ölwanne	Moteurs avec carter d'huile en deux parties	Para motores con dos juntas de cárter
213	Equipment Variant: Kadett E, Vectra	Ausstattungsvariante: Kadett E, Vectra	Version d'équipement: Kadett E, Vectra	Variante de equipamiento: Kadett E, Vectra
214	Radial Oil Seal, automatic transmission	Wellendichtring, Automatikgetriebe	Bague d'étanchéité, transmission automatique	Anillo retén, transmisión automática
215	Not for engine code: F9Q 730	nicht für Motorcode: F9Q 730	pas pour code moteur: F9Q 730	no para cód. mot.: F9Q 730
216	6 bolt flywheel	6 Bolzenschwungrad	Volant à 6 boulons	Volante 6 pernos
217	For metal manifolds only	Für Metallhaube	Seulement pour collecteur en métal	Solo para colectores de metal
218	Contains JN736	beinhaltet JN736	Contient JN736	Contiene JN736
219	Contains JP065	beinhaltet JP065	Contient JP065	Contiene JP065
220	For cylinder: 4, 8	für Zylinder: 4, 8	pour cylindre: 4, 8	para cilindro: 4, 8
221	Contains LB536 and LB162	Mit LB536 + LB162	Contient LB536 et LB162	Contiene LB536 y LB162
222	Contains GREEN valve stem seals	Ventilschaftdichtringfarbe: GRUEN	Joint de queue de soupape VERT	Contiene retenes de válvula VERDES
223	Contains LB161 and LB162	Mit LB161 + LB162	Contient LB161 et LB162	Contiene LB161 y LB162
224	Contains BLACK valve stem seals	Ventilschaftdichtringfarbe: SCHWARZ	Joint de queue de soupape NOIR	Contiene retenes de válvula NEGROS
225	Drive Type: Front Wheel Drive	Antriebsart: Frontantrieb	Mode de traction: traction avant	Tipo de tracción: Tracción delantera
230	+ 1 x JN581 required	+ 1 x JN581 zusätzlich	A ajouter + 1 x JN581	Necesarios + 1 x JN581
231	Non Recessed Block Engines	Für nicht geschliffenen Block	Bloc moteur sans cavité	Carcasa sin ahueque de camisa
233	With BH860	Mit BH860	Avec BH860	Con BH860
234	With BN040	Mit BN040	Avec BN040	Con BN040
235	Height 2 [mm]: 19.3	Höhe 2 [mm]: 19.3	Hauteur 2 [mm]: 19.3	Altura 2 [mm]: 19.3
238	Includes JM5034	beinhaltet JM5034	JM5034 inclus	Incluye JM5034
239	Includes JM5074	beinhaltet JM5074	JM5074 inclus	Incluye JM5074
240	Not for country-spec. model: Canada	nicht für Länderausführung: Kanada	pas pour version pays: Canada	no modelo país: Canadá
241	Not for country-spec. model: USA	nicht für Länderausführung: USA	pas pour version pays: LES Etats-Unis	no modelo país: LOS E.E.U.U.
242	Not for country-spec. model: Europe	nicht für Länderausführung: Europa	pas pour version pays: Europe	no modelo país: Europa
243	Fuel Mixture Formation: Carburettor	Kraftstoffaufbereitung: Vergaser	Mélange air-carburant: Carburateur	Preparación de la mezcla carburante: Carburador
244	Fuel Mixture Formation: Petrol Injection	Kraftstoffaufbereitung: Benzineinspritzung	Mélange air-carburant: Injection d'essence	Preparación de la mezcla carburante: Inyección de gasolina
245	Radial Oil Seal Set	Wellendichtring	Bague d'étanchéité	Anillo retén
246	Alternative - Recommend use with uprated ladder rail LCN 000140L	Alternative - empfohlene Verwendung mit leistungsverstärktem Rail LCN 000140L	Utilise avec LCN 000140L	Uso con LCN 000140L
247	Contains BW5750	Mit BW5750	Contient BW5750	Contiene BW5750
248	Contains 1 x JH5005	Mit 1 x JH5005	Contient 1 x JH5005	Contiene 1 x JH5005
249	Heavy Duty Version	Schwerlast-/LKW Version	Version Poids Lourds	Version Vehiculo Pesado
250	to engine cylinder: 2	zu Motorzylinder: 2	sous cylindre moteur: 2	A cilindro de motor: 2
251	Bolt / Nut Version: without plain washer	Schrauben-/Mutterausführung: ohne Unterlegscheibe	Type d'écrou: sans rondelle de calage	Modelo de tornillo/tuerca: sin arandela
252	Auxiliary valve stem seal	Zusätzlichen Ventilschaft-Dichtung	Joint queue de soupape auxiliaire	Retén de válvula auxiliar
273	Not for engine code: BLS	nicht für Motorcode: BLS	pas pour code moteur: BLS	no para cód. mot.: BLS
274	With heat shield	Mit Hitzeschild	Avec ecran thermique	Con pantalla protectora



211	Vehicle Equipment: for vehicles without air conditioner	Dla samochodów bez klimatyzacji	Оборудование автомобиля: для автомобилей без кондиционера	معدة المركبة: للمركبات التي لا تحتوي على مكيف هواء
212	For engines with two piece oil pan	Dla silników z dwuczęściową miską olejową	Для двигателей с двухсекционным поддоном картера	للمحركات المزودة بعلبة زيت من جزئين
213	Equipment Variant: Kadett E, Vectra	Dla Kadett E, Vectra	Вариант оборудования: Kadett E, Vectra	مغير المعدة: كاديت إي، فيكترا
214	Radial Oil Seal, automatic transmission	Olejowe uszczelnienie promieniowe, automatyczna skrzynia biegów	Радиальный сальник, автоматическая коробка передач	مانع تسريب قطري، ناقل حركة تلقائي
215	Not for engine code: F9Q 730	Nie dla silnika oznaczonego kodem: F9Q 730	Кроме двигателей со следующими кодами: F9Q 730	ليس لكود المحرك: F9Q 730
216	6 bolt flywheel	Koło zamachowe na 6 śrub	6-болтовый маховик	حداقة بستة مسامير
217	For metal manifolds only	Tylko dla kolektorów z metalu	Только для металлических коллекторов	للمجامع المعدنية فقط
218	Contains JN736	Zawiera JN736	Содержит JN736	يُتضمن JN736
219	Contains JP065	Zawiera JP065	Содержит JP065	يُتضمن JP065
220	For cylinder: 4, 8	Do cylindrów: 4, 8	Для цилиндров: 4, 8	للاسطوانة: 4, 8
221	Contains LB536 and LB162	Zawiera LB536 i LB162	Содержит LB536 и LB162	يُتضمن LB536 و LB162
222	Contains GREEN valve stem seals	Z ZIELONYMI uszczelnieniami trzonka zaworu	Содержит ЗЕЛЕНЫЕ уплотнения штоков клапанов	يحتوي على موانع تسريب جذر صمام أخضر
223	Contains LB161 and LB162	Zawiera LB161 i LB162	Содержит LB161 и LB162	يُتضمن LB161 و LB162
224	Contains BLACK valve stem seals	Z CZARNYMI uszczelnieniami trzonka zaworu	Содержит ЧЕРНЫЕ уплотнения штоков клапанов	يحتوي على موانع تسريب جذر صمام أسود
225	Drive Type: Front Wheel Drive	Rodzaj napędu: napęd na koła przednie	Тип привода: Передний привод	نوع الدفع: دفع العجلة الأمامية
230	+ 1 x JN581 required	Wymagane +1 x JN581	+ требуется 1 x JN581	+ مطلوب 1 x JN581
231	Non Recessed Block Engines	Silniki bez wgłębienia w bloku	Двигатели без углубления в блоке	محركات بكتل غير مجوفة
233	With BH860	Z BH860	С BH860	مع BH860
234	With BN040	Z BN040	С BN040	مع BN040
235	Height 2 [mm]: 19.3	Wysokość 2 [mm]: 19.3	Высота 2 [мм]: 19.3	الارتفاع 2 [مم]: 19.3
238	Includes JM5034	Zawiera JM5034	Включает JM5034	يُتضمن JM5034
239	Includes JM5074	Zawiera JM5074	Включает JM5074	يُتضمن JM5074
240	Not for country-spec. model: Canada	Nie dla modelu specjalnego dla kraju: Kanada	Кроме моделей, предназначенных для сбыта в следующих странах: Канада	ليس لمواصفات البلد الطراز: كندا
241	Not for country-spec. model: USA	Nie dla modelu specjalnego dla kraju: USA	Кроме моделей, предназначенных для сбыта в следующих странах: USA	ليس لمواصفات البلد. نموذج: الولايات المتحدة الأمريكية
242	Not for country-spec. model: Europe	Nie dla modelu specjalnego dla kraju: Europa	Кроме моделей, предназначенных для сбыта в следующих странах: Европа	ليس لمواصفات البلد الطراز: أوروبا
243	Fuel Mixture Formation: Carburettor	Tworzenie mieszanki paliwowo-powietrznej: Gaźnik	Подготовка топливозоудушной смеси: Карбюратор	تكوين خليط الوقود: المكربن
244	Fuel Mixture Formation: Petrol Injection	Tworzenie mieszanki paliwowo-powietrznej: Wtrysk paliwa	Подготовка топливозоудушной смеси: Впрыск бензина	تكوين خليط الوقود: حقن البنترول
245	Radial Oil Seal Set	Zestaw olejowych uszczelnień promieniowych	Комплект радиальных сальников	مجموعة مانع تسريب قطري
246	Alternative - Recommend use with uprated ladder rail LCN 000140L	Alternatywa - Rekomendowane użycie z nowocześniejszą szyną LCN 000140L	Альтернатива — рекомендуется использовать с модернизированной рамой лестничного типа LCN 000140L	استخدام بديل مستحسن مع القضيب السلمي المطور LCN 000140L
247	Contains BW5750	Zawiera BW5750	Содержит BW5750	يُتضمن BW5750
248	Contains 1 x JH5005	Zawiera 1 x JH5005	Содержит 1 x JH5005	يُتضمن 1 x JH5005
249	Heavy Duty Version	Wersja: ciężkie warunki pracy	Усиленный вариант	نسخة للأعمال الثقيلة
250	to engine cylinder: 2	do cylindra: 2	к цилиндрам: 2	إلى اسطوانة المحرك: 2
251	Bolt / Nut Version: without plain washer	Wersja śruba/ nakretka: bez podkładki	Тип болта/гайки: без плоской шайбы	نسخة مسامير الربط/الصامولة بدون وردة عادية
252	Auxiliary valve stem seal	Pomocnicze uszczelnienie trzonka zaworu	Вспомогательное уплотнение штока клапана	مانع تسريب صمام إضافي
273	Not for engine code: BLS	Nie dla silnika oznaczonego kodem: BLS	Кроме двигателей со следующими кодами: BLS	ليس لكود المحرك: BLS
274	With heat shield	Z osłoną termiczną	С теплозащитным экраном	مع وافي الحرارة

A NEW LOOK FOR THE SEALING EXPERT



CURRENT

NEW

CHECK OUT OUR NEW ANTI-COUNTERFEIT PROGRAMME

With these features on all new engine parts packaging Federal-Mogul enables you to check reliably that the parts inside are Original Quality.



1

LOOK FOR THE HOLOSPOT®

The Holospot® label features a 4-digit alphanumeric code.

Please check it to make sure that:

- The 4-digit code appears in rainbow colours using the light of the magnifier and is different on each pack
- The Federal-Mogul logo also appears in the Holospot®. The last 4 digits of the alphanumeric code have to be the same as the ones in the Holospot®

2

CHECK THE UNIQUE CODE ONLINE AT WWW.FMECAT.EU

Each Federal-Mogul part has a unique code which is displayed on the labels in an alphanumeric and Data Matrix format. A Data Matrix code is a 2-dimensional [2-D] matrix barcode.

The Unique Code can be verified in 3 different ways:

- Typing in the Unique Code
- Reading the 2-D code with a 2-D scanner
- Using a mobile phone (Nokia Nseries, Eseries)

3

PROTECTION

Special label design means any attempt to remove or swap the label will result in tearing



Go to www.fmecat.eu for verification

GASKETS



PERFORMS UNDER PRESSURE



- Widest coverage with 10 500 gasket, oil seal and headbolt references
- OE-specification gasket designs and materials engineered in Germany
- LEM and HTA award-winning technologies included
- Innovative, market-leading anti-counterfeit programme



