



2004/2005



Electrical accessories

Accessoires électriques

Accesorios electricos

Acessórios elétricos

Accessori elettrici

Electrische accessoires

Elektrisches Zubehör

Akcesoria elektryczne

Elektrikli aksesuarlar

Электроприборы

Valeo

- Electrical accessories
- Accessoires électriques
- Accesorios eléctricos
- Acessórios elétricos
- Accessori elettrici
- Electrische accessoires
- Elektrisches Zubehör
- Akcesoria elektryczne
- Elektrikli aksesuarlar
- Электроприборы

- Horns
- Avertisseurs
- Bocinas
- Buzinas
- Segnalatori acustici
- Hoorns
- Hupen
- Sygnały dźwiękowe
- Корна
- Звуковые сигналы



- Flasher units
- Centrales clignotantes
- Centrales de intermitencia
- Centrais de intermitentes
- Lampeggiatori
- Knipperlicht relais
- Blinkerrelais
- Przerzywacze
- Flaşör ünıteleri
- Проблесковые приборы



- Relays
- Relais
- Relés
- Relés
- Relé
- Relais
- Relais
- Przekazniki
- Röle
- Реле



- Comfort relays
- Temporisateurs de confort
- Temporizadores de confort
- Temporizadores de conforto
- Temporizzatori di confort
- Comfort relais
- Komfortrelais
- Przekazniki komfortu
- Devre anahtarı ve röleler
- Переключатели



- Cigar lighters and multifunctional plugs
- Allume-cigares et prises multifonctions
- Encendores y tomas multifunción
- Isqueiros e tomadas multifunção
- Accendisigari e prese multifunzione
- Sigarettenaanstecker en Multi-functionele power aansluiting
- Zigarettenanzünder und 12V Buchse
- Zapalniczki i wielofunkcyjne gniazda zasilania
- Çakmak ve çok amaçlı priz
- Прикуриватели и многофункциональные источники питания





























- Pre-heating timers
- Temporisateurs de préchauffage
- Temporizadores de precalentamiento
- Temporizadores de pré-aquecimento
- Temporizzatori di preriscaldamento
- Voor-gloeı relais
- Glühkerzen
- Przekazniki czasowe włączania śwıec żarowych
- Ön ısıtma zamanlayıcısı
- Таймер включения свечей накала



- Sockets and plugs
- Prises et fiches
- Tomas y conectores
- Tomadas e fichas
- Prese e connettori
- Contactdozen en stekkers
- Steckdosen und Stecker
- Złącza i gniazda
- Priz ve fişler
- Розетки и штепсели

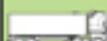







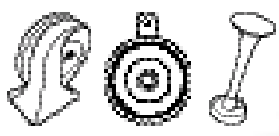

	<p>Country Specific Pays d'application País de aplicación País de Aplicação Paese d'applicazione Land applicatio Land der Anwendung Kraj przeznaczenia Ülke uygulamalar Страна предназначения</p>	 <p>Coil relay contact Contacteur à relais à bobine (d'appel isolée) Contactor con relé y bobina Ligação com relé e bobina Ligação com relé e bobina Contattore a relé con bobina Relais mot spool Relais Cewka Rôle bobin bağılant s Катушка</p>	 <p>Multifunctional plug Prise multifonctions Toma multifunción Toma multifunção Presa multifunzione Multi functionele spannings aansluiting 12V Buchse Wielofunkcyjne gniazdo zasilania Çok amaçlı priz многофункциональные источники питания</p>
<p>+</p>	<p>With Avec Con Com Con Met Mit Z. Birlikte C</p>	 <p>Flasher unit Centrale clignotante Central de intermitencia Central de intermitente Lampeggiatore Knipperlicht Relais Blinkerrelais Przerywacz Flaşör ünitesi Проблесковые приборы</p>	
<p>-</p>	<p>Without Sans Sin Sem Senza Zonder Ohne Bez Olmadan Без</p>	 <p>Pre-Heating timer Temporisateur de préchauffage Temporizador de precalentamiento Temporizador de pré-aquecimento Temporizzatore di preriscaldamento Voor-gloeit relais Glühkerze Przełącznik czasowy włączania świece żarowych On s tma zamanlay c s Таймер включения свечей накала</p>	
<p>+/...</p>	<p>Supplementary Information Information supplémentaire Información suplementaria Informação suplementar Informazione supplementare Additionele informatie Zusatzinformation Informacje uzupełniające Ek aç klama Техническая информация</p>	  <p>Comfort relay Temporisateur de confort Temporizador de confort Temporizador de conforto Temporizzatore di confort Comfort relais Komfortrelais Przełącznik Devre anahtarlar Переключатели</p>	
  	<p>Horn Avertisseur Bocina Buzina Segnalatore acustico Horn Hupe Sygnał dźwiękowy Korna Звуковые сигналы</p>	 <p>Socket Prise Toma Tomada Presa Stekker Stecker Złącze Priz Розетки</p>	
	<p>Relay Relais Relé Relé Relé Relais Relais Przełącznik Rôle Реле</p>	 <p>Plug Fiche Conector Ficha Connettore stekkerdoos Steckdosen Gniazdo Fişler штепсели</p>	
	<p>Connector for relay Connecteur pour relais Conector para relé Ligação para relés Connettore per relé Stekkerverbinding voor relais Relaisstecker Gniazdo przekaźnika Rôle bağılant s Контакт для реле</p>	 <p>Cigar lighter Allume-cigare Encendedor Isqueiro Accendisigari sigarettenaansteker Zigarettenanzünder Zapalniczka Çakmak прикуриватели</p>	

 <p>Page number N° de page Número de Página Número da página N° di pagina Pagina Seite Numer strony Sayfa numaras Номер страницы</p>	 <p>Fork lift truck Chariot élévateur Carretilha elevadora Braço elevador Carrello elevatore Vorkhofttruck Gabelstapler Winda załadowcza Damperli kamyon Товарные лифты</p>	 <p>Manufacturer references Références constructeur Referencias constructor Referências do fabricante Riferimenti costruttore Original number OE-Nr. Numer OE Araç üretici referans Номер производителя</p>
 <p>Véhicule Vehículo Vehículo Viatura Veicolo Voertuig Fahrzeug Pojazd Araçlar Автомобиль</p>	 <p>Motorcycle Motocycle Motocicleta Mota Motociclo Motor Motorrad Motocykl Motosiklet Мотоцикл</p>	<p>Intensity Intensité Intensidad Intensidade Intensità Intensiteit Stromaufnahme Nateženie Şiddet Напряжение</p>
 <p>Saloon Berline Berlina Berlina Berlina Sedan PKW Sedan Sedan Седан</p>	 <p>Application Date Date d'application Fecha de aplicación Data de aplicação Data d'applicazione Bouwjaar Baujahr Data produkcji samochodu Y I Дата производства</p>	<p>Tension Tension Tensión Tensão Tensione Spanning Spannung Napięcie Gerilim Напряжение</p>
 <p>Commercial Vehicle Utilitaire Vehículo comercial ligero Veículo comercial ligeiro Veicoli Commerciali Commercieel voertuig Nutzfahrzeug Samochody dostawcze Ticari araç Грузовые автомобили</p>	 <p>Photo Photo Foto Foto Foto Foto Foto Zdjęcie Fotograf foto</p>	<p>Frequency Fréquence Frecuencia Frequência Frequenza Frequentie Frequenz Częstotliwość Frekans Частота</p>
 <p>Truck Poids-Lourd Vehículo industrial Veículo pesado Veicolo pesante Truck NKW Samochod ciężarowy Ağ r vas ta Грузовые автомобили</p>	 <p>Cancelled Supprimée Suprimida Suprimida Annulato Uitgeput Nicht mehr lieferbar Niedostępny İptal Недоступен</p>	 <p>Homologation Homologation Homologación Homologação Omologazione Homologatie Zulassung Homologacja Homologasyon Сертификация</p>
 <p>Tractor Engin agricole Tractor Tractor Trattore Tractor Landmaschine Traktor Zirai araç Тракторы</p>	 <p>Replaced (with) Remplacée par Sustituido (por) Substituido (por) Sostituito (da) Vervangen (door) Ersetzt durch Zamieniony (na) Değişt Заменён</p>	 <p>Designation Designation Denominación Denominação Designazione Omschrijving Identifizierung Przeznaczenie Tan m Предназначение</p>
 <p>Industrial vehicle Engin Industriel Obras publicas Obras públicas Motore industriale Industrieel voertuig Industriefahrzeug Pojazd budowlany İş makinası Строительный машины</p>	 <p>Valeo references Références Valeo Referencias Valeo Referências Valeo Riferimenti Valeo Valeo referencias Valeo Artikel-Nr. Nr referencji Valeo referanslar Номер Valeo</p>	 <p>Colour Couleur Color Cör Colore Kleur Farbe Kolor Renk Цвет</p>



**CONTENTS • SOMMAIRE • INDICE • ÍNDICE • SOMMARIO •
INHOUD • INHALT • SPIS TREŚCI • İÇİNDEKILER • СОДЕРЖАНИЕ •**



1		<p>Horns Bocinas Segnalatori acustici Hupen, Hörner und Sirenen Korna</p>	<p>Avertisseurs Buzinas Hoorns Sygnaly dźwiękowe Звуковые сигналы</p>	5
2		<p>Relays Relés Relé Relais Röleler</p>	<p>Relais Relés Relais Przekazniki Реле</p>	33
3		<p>Flasher units Centrales de intermitencia Lampeggiatore Blinkerrelais Flaşör üniteleri</p>	<p>Centrales clignotantes Centrais de intermitentes Knipperlicht Relais Przerywacze Проблесковые приборы</p>	85
4		<p>Pre-Heating timers Temporizadores de precalentamiento Temporizzatori di preriscaldamento Glühkerzen Ön ısıtma zamanlayıcıları</p>	<p>Temporisateurs de préchauffage Temporizadores de pré-aquecimento Voor-gloeï relais Przekazniki czasowe włączania świec żarowych Таймер включения свечей накала</p>	95
5		<p>Comfort relays Temporizadores de confort Temporizzatori di confort Komfortrelais Devre anahtarları</p>	<p>Temporisateurs de confort Temporizadores de conforto Comfort relais Przełączniki Переключатели</p>	119
6		<p>Sockets and plugs Tomas y clavijas Prese e schede Steckdosen und Stecker Priz ve fişler</p>	<p>Prises et fiches Machos e fêmeas Stekkers en stekkendoos Gniazda i złącza Розетки и штепсели</p>	127
7		<p>Cigar lighters & multifunctional plugs Encendedores & tomas multifunción Accendisigari & prese multifunzione Cigaretten aansteker & multi-funcionele spannings power aansluiting Zigarettenanzünder & 12V Buchse Zapalniczki & wielofunkcyjne gniazda zasilania Çakmak ve çok amaçlı priz Прикуриватели & многофункциональные источники питания</p>	<p>Allume-cigares & prises multifonctions Isqueiros & tomadas multifunção</p>	147
8		<p>Numerical lists Listas numéricas Liste numeriche Numerische Listen Sayısal liste</p>	<p>Listes numériques Listas numéricas Nummerieke lijst Lista referencji Список номеров</p>	157

Valeo		Valeo		Valeo		Valeo	
241621		479164		634030		643840	
241622		479165		634031		643841	
241623		479166		641428		643842	
241624		479167		641429		643843	
241625		479168		642681		643844	
251014		630023		642682		643845	
251015		630024		642683		643846	
251016		630025		642684		643847	
251017		630026		642685		643848	
251018		630027		643829		643849	
251019		634002		643830		643850	
251020		634003		643831		643851	
251021		634004		643832		643852	
251022		634005		643833		643853	
479158		634006		643834		643854	
479159		634007		643835		643855	
479160	Nautilus	634008		643836		643856	
479161		634009		643837			
479162		634010		643838			
479163		634011		643839			



Valeo		
026730		✓
083950		✓
083951		✓
083959		✓
083965		✓
083970		✓
083973		✓
084031	Fuse box/Boitier fusibles	✓
084032	Fuse box/Boitier fusibles	✓
084040		✓
084041		✓
084043		✓
084203		✓
084204		✓
084205		✓
245602		✓
245606		✓
245613		✓
245614		✓
245617		✓

Valeo		
245619		→245600
245620		✓
251001	-	✓
251002	-	✓
251003	-	✓
251004	-	✓
251005	-	✓
251006	-	✓
251007		✓
251008	-	✓
251009	-	✓
251010	-	✓
251011	-	✓
251012	-	✓
251013		✓
479007		→479158
479008		→479159
479011		✓
479018		✓
479020		→479009

Valeo		
479030		→479162
479031		→479163
479117		✓
479118		✓
479134		✓
479137		✓
479138		→479162
479139		→479163
479140		→479164
479141		→479165
479142		✓
479143		✓
479144		→479163
479145		✓
479146		→479165
479147		→479162
479148		→479163
479149		✓
479150		✓
630010		✓



Valeo		
630020		✓
630021		✓
630022		→630023
634000		✓
634001		✓
634016		✓
634017		✓
634018		✓
634019		✓
634020		✓
634021		✓
634022		✓
634024		✓
634700		✓
634701		✓
634702		✓
634704		✓
634705		✓
634706		✓
634707		✓

Valeo		
641192		→641421
642278		✓
642409		✓
642616		✓
642631		✓
642680		✓
643102		→643508
643104		→643508
643105		→643822
643115		✓
643138		✓
643283		✓
643284		✓
643285		✓
643293		✓
643374		✓
643382		✓
643384		✓
643385		✓
643393		✓

Valeo		
643394		→643828
643395		→643828
643397		→643658
643507		→643508
643526		→643822
643811		✓
643812		✓
643814		✓
643816		✓
643817		→245622
643821		✓
649500		✓
745404		✓
745405		✓
745437	Fuse box/Boitier fusibles	✓
745708		✓
745814		✓
925501	-	✓
925503	-	✓

1

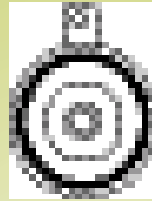

Horns
Avertisseurs
Bocinas
Buzinas
Segnalatori acustici
Hoorns
Hupen, Hörner und Sirenen
Sygnaly dźwiękowe
Korna
Звуковые сигналы

	<p>Disc horn Electromagnétique à disque Bocina electromagnética de disco Buzina electromagnética de disco Elettromagnetico a disco Schijf hoorn Scheibenhupe Sygnat dźwiękowy (płaski) Disk elektromanetyk korna Электромагнитный - диск</p>		<p>Colour Couleur Color Còr Colore Kleur Farbe Kolor Renk Цвет</p>		<p>Polarity Polarité Polaridad Polaridade Polarità Polariteit Polarität Biegunowość İki kutuplu Полярность</p>
	<p>Electromagnétique à trompe (escargot) Bocina electromagnética de caracol Buzina electromagnética de caracol Elettromagnetico a chiocciola Electromagnetische hoorn Elektromagnetische Hupe Sygnat dźwiękowy (ślimak) Salyangoz elektromanetyk korna Электромагнитный - рупор</p>		<p>Sound pressure level at 2m Niveau sonore à 2m Nivel sonoro a 2 m Nível sonoro a 2 m Livello di pressione sonora a 2m Geluidsdruk niveau na 2m Schalldruck bei 2m Poziom dźwięku przy 2m 2m'deki ses şiddeti Уровень звука при 2м</p>		<p>Emergency vehicle horn Avertisseur pour véhicule prioritaire Bocina para vehículo de emergencia Buzina para veículos de emergência Segnalatore acustico di emergenza Sirene Sirene</p>
	<p>Sygnat dźwiękowy dla pojazdów uprzywilejowanych Geçiş üstünlüklü araç sireni Сигналы для спецмашин</p>		<p>Sound Type Type son Tipo de sonido Tipo de som Tipo di suono Geluidstype Tontyp Typ dźwięku Ses tipi Тип звука</p>		<p>Dual Polarity Bipolaire Bipolar bipolar Polarità doppia Dual polariteit Zweipolig Podwójna biegunowość Çift kutuplu двойная полярность</p>
	<p>Reverse alarm Alarme de recul Alarma de marcha atrás Indicador sonoro de marcha-a-trás Segnalatore acustico di retromarcia Achteruitrij alarm Rückfahrwarnerr Dźwiękowy sygnalizator cofania Geri vites alarmı Сигналы заднего хода</p>		<p>High Aigu Agudo Agudo Alto Hoog Hoch Wysoki Yüksek Высокий</p>		<p>Power Consumption Consumation en fonctionnement Consumo en funcionamiento Consumo em funcionamento Assorbimento di corrente Power consumptie Energieverbrauch bei Benutzung Zużycie prądu Güç tüketimi Расход тока</p>
	<p>Jericho Jericho Bocina de aire comprimido Jericho Buzina de ar comprimido Jericho Jericho Jericho Jericho Jericho Jeriko Jericho</p>		<p>Medium Medio Médio Medio Medium Mittel Średni Orta Средний</p>		<p>Static Power Consumption Consumation au repos Consumo en reposo Consumo em repouso Assorbimento di corrente a riposo Statische power consumptie Energieverbrach im Standby Stale zużycie prądu Durağan haldeki tüketim Постоянный расход тока</p>
	<p>Compressor Compresseur Compresor Compressor Compressore Compressor Kompressor Kompresor Kompresör Компрессор</p>		<p>Low Grave Grave Grave Basso Laag Tief Niski Açık Низкий</p>		<p>Day Jour Dia Dia Giorno Dag Tag Dzień Gündüz День</p>
	<p>Trumpet Trompe Bocina electromagnética de trompeta Buzina electromagnética de trompeta Trombe Meertonige claxon Trompeta Fanfar Trompet Трубы</p>		<p>High + low with relay Aigu + grave avec relais Agudo + grave con relés Agudo + grave com relés Alto + basso con relé Hoog + laag met relais Hoch + tief mit Relais Wysoki + niski z przekaźnikiem Röleli yüksek + açık Низкий + высокий с реле</p>		<p>Night Nuit Noche Noite Notte Nacht Nacht Noc Gece Ночь</p>
	<p>Module + 2 speakers Module + 2 haut-parleurs Módulo con 2 altavoces Módulo + 2 colunas Modulo + 2 altoparlanti Module + 2 speakers Modul + 2 Lautsprecher Modul + 2 sygnały Modül + 2 hoparlör Модуль + 2 сигнала</p>		<p>Homologation Homologation Homologación Homologação Omologazione Homologatie Zulassung Homologacja Homologasyon Сертифицирование</p>		<p>Revolutions Cadence Cadencia Cadência Cadenza/frequenza Ritmes Drehzahlen Tempo Devir Темп</p>



Electronic / Electronique	Electronic Electronique Electrónica Electrónica Elettronico Elektronisch Elektronisch Elektroniczny Elektronik Электронный	UMH	Ambulance Unité Mobile Hospitalière Ambulancia Ambulancia Ambulância Unità mobile ospedaliera Mobiele ziekenhuis unit Krankenwagen Karetka pogotowia Hastane aracı Санитарный автомобиль
Air powered / Electro- pneumatique	Air Powered Electropneumatique Electroneumáticas Electroneumáticas Elettropneumatico Electro-pneumatisch Elektropneumatisch Elektropneumatyczny Havalı Электропневматический	Black / Noir	Black Noir Negro Preto Nero Zwart Schwarz Czarny Siyah Чёрный
Tone / Ton	Tone Ton Tono Tom Tono Toon Ton Ton Seviye Тон	Chromed / Chromé	Chromed Chromé Cromada Cromada Cromato Verchroomd Verchromt Chromowany Crom Хромистый
Cycles / Min.	Revolutions per minute Cycles par minute Ciclos por minuto Ciclos por minuto Cicli per minuto Cyclus per minuut Umdrehungen pro Minute Cykli na minutę Dakikadaki dönüş sayısı Циклов на минуту	Red / Rouge	Red Rouge Rojo Vermelho Rosso Rood Rot Czerwony Kırmızı Красный
Ambulance	Ambulance Ambulance Ambulancia Ambulância Ambulanza Ambulance Krankenwagen Ambulans Sankurtaran Санитарный автомобиль	Fr	France France Francia França Francia Frankrijk Frankreich Francja Fransa Франция
Gendarmerie	Police Station Gendarmerie Policía Esquadra de Policia Forze dell'ordine Politiebureau Polizei Policja Polis merkezi Полиция		
Police	Police Police Policía Policia Polizia Politie Polizei Policja Polis ГАИ		
Pompier	Fire brigade Pompiers Bombero Bombeiro Pompiere brandweer Feuerwehr Straż pożarna İtfaiye Пожарный автомобиль		



ELECTROMAGNETIC/ELECTROMAGNÉTIQUE/ELECTROMAGNÉTICAS/ ELECTRO-MAGNETISCH/ELEKTROMAGNETISCH/ELEKTROMAGNETYCZNY/

TR99

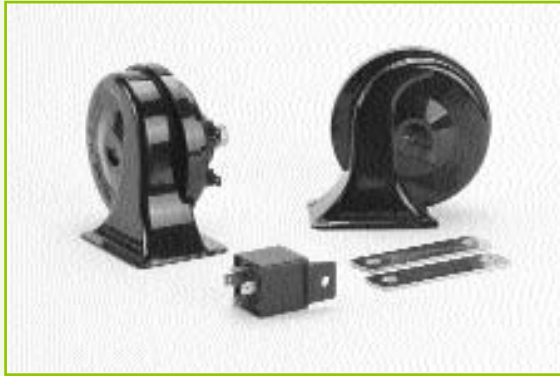

Valeo



U

I

479001	E2 e2 884		Black / Noir	12 V	5,5A
479002	E2 e2 884		Black / Noir	12 V	5,5A
479003	E2 e2 884		Red / Rouge	12 V	5,5A
479004	E2 e2 884		Red / Rouge	12 V	5,5A
479013	E2 e2 884		Black / Noir	12 V	11A
			Black / Noir	12 V	11A
479005	E2 e2 884		Black / Noir	12 V	5,5A
479006	E2 e2 884		Black / Noir	12 V	5,5A
479012	E2 e2 884		Black / Noir	12 V	11A
			Black / Noir	12 V	11A
479009	E2 e2 884		Black / Noir	12 V	5,5A
479010	E2 e2 884		Black / Noir	12 V	5,5A
479158	E2 e2 884		Black / Noir	24 V	2,5A
479159	E2 e2 884		Black / Noir	24 V	2,5A



ELECTROMAGNÉTICAS/ELETTROMAGNETICO/ ELEKTROMANYETIK/Электромагнитный

	Hz	dB				
H	500 +/- 35 HZ	109 db		1		
L	420 +/- 35 HZ	109 db		1		
H	500 +/- 35 HZ	109 db		1		
L	420 +/- 35 HZ	109 db		1		
H	500 +/- 35 HZ	112 db		1		
L	420 +/- 35 HZ	112 db		1		
H	500 +/- 35 HZ	109 db		2		
L	420 +/- 35 HZ	109 db		2		
H	500 +/- 35 HZ	112 db		2		
L	420 +/- 35 HZ	112 db		2		
H	500 +/- 35 HZ	109 db		2		
L	420 +/- 35 HZ	109 db		2		
H	500 +/- 35 HZ	109 db		2		
L	420 +/- 35 HZ	109 db		2		



ELECTROMAGNETIC/ELECTROMAGNÉTIQUE/ELECTROMAGNÉTICAS/
ELECTRO-MAGNETISCH/ELEKTROMAGNETISCH/ELEKTROMAGNETYCZNY/

TM 80

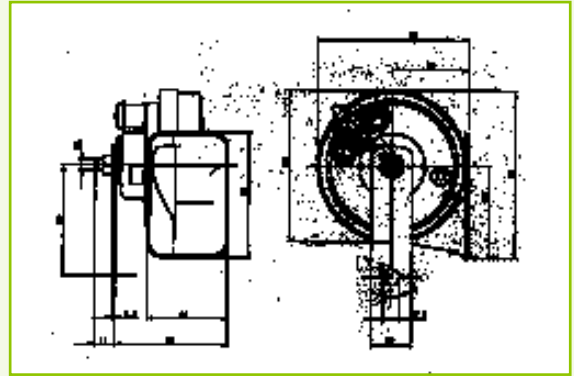

Valeo



U

I

479153	0052383	Ø 82mm	Black / Noir	12 V	5,5A
479154	0052383	Ø 82mm	Black / Noir	12 V	5,5A
479155	0052383	Ø 82mm	Black / Noir	12 V	11A
			Black / Noir	12 V	11A

TM 80 MAGNUM

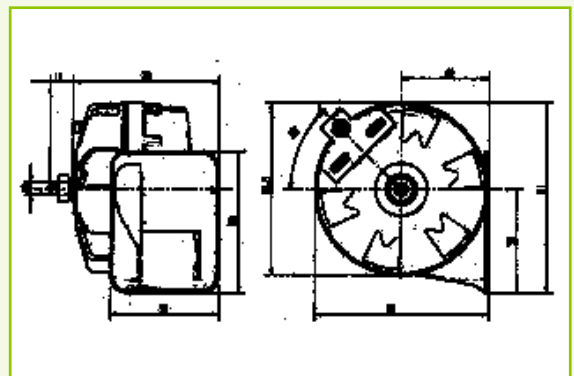

Valeo



U

I

479161	0058098	(x2) Ø 80mm	Black / Noir	12 V	12A
			Black / Noir	12 V	12A
479167	0058098	Ø 80mm	Black / Noir	12 V	12A
479168	0058098	Ø 80mm	Black / Noir	12 V	12A



ELECTROMAGNÉTICAS/ELETTROMAGNETICO/ ELEKTROMANYETIK/Электромагнитный

H 500 +/- 25 HZ 109 db

2



L 410 +/- 20 HZ 109 db

2



H 500 +/- 25 HZ 112 db

2



L 410 +/- 20 HZ 112 db

2



H 500 +/- 25 HZ 115 db

2



L 410 +/- 20 HZ 115 db

2



H 500 +/- 25 HZ 115 db

2



L 410 +/- 20 HZ 115 db

2





ELECTROMAGNETIC/ELECTROMAGNÉTIQUE/ELECTROMAGNÉTICAS/
ELECTRO-MAGNETISCH/ELEKTROMAGNETISCH/ELEKTROMAGNETYCZNY/

HF 80

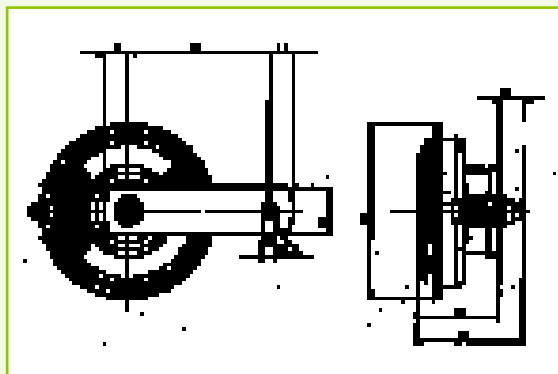

Valeo	H	TYPE	Ø	U	I	
479151	0054593		Ø 80mm	Chromed / Chromé	12 V	4A
479152	0054593		Ø 80mm	Chromed / Chromé	12 V	4A
479166	0054593		(x2) Ø 80mm	Chromed / Chromé	12 V	9A
				Chromed / Chromé	12 V	9A

HK9

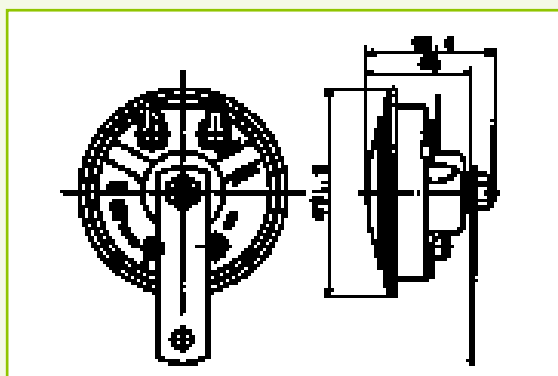

Valeo	H	TYPE	Ø	U	I	
479162	E200-1017		Ø 92mm	Chromed / Chromé	12 V	3A
479163	E200-1017		Ø 92mm	Chromed / Chromé	12 V	3A
479164	E200-1017		Ø 92mm	Chromed / Chromé	24 V	1,5A
479165	E200-1017		Ø 92mm	Chromed / Chromé	24 V	1,5A



ELECTROMAGNÉTICAS/ELETTROMAGNETICO/ ELEKTROMANYETIK/Электромагнитный

	Hz	dB				
--	----	----	--	--	--	--

H	430 +/- 21 HZ	109 db				
---	---------------	--------	--	--	--	--

L	340 +/- 18 HZ	109 db				
---	---------------	--------	--	--	--	--

H	430 +/- 18 HZ	112 db				
---	---------------	--------	--	--	--	--

L	340 +/- 18 HZ	112 db				
---	---------------	--------	--	--	--	--

	Hz	dB				
--	----	----	--	--	--	--

H	425 HZ	110 db				
---	--------	--------	--	--	--	--

L	340 HZ	110 db				
---	--------	--------	--	--	--	--

H	425 HZ	110 db				
---	--------	--------	--	--	--	--

L	340 HZ	110 db				
---	--------	--------	--	--	--	--



AIR POWERED/ELECTROPNEUMATIQUE/ELECTRONEUMÁTICAS/
ELECTRO-PNEUMATISCH/ELEKTROPNEUMATISCH/

JERICO - AIR

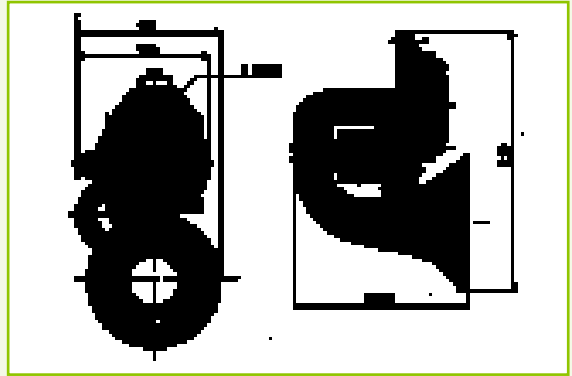

Valeo



U

I

479075

E200-816

(6x8mm)

Black / Noir

12-24 V

2A

479076

E200-816

(4x6mm)

Black / Noir

12-24 V

2A

HYPERSONIC

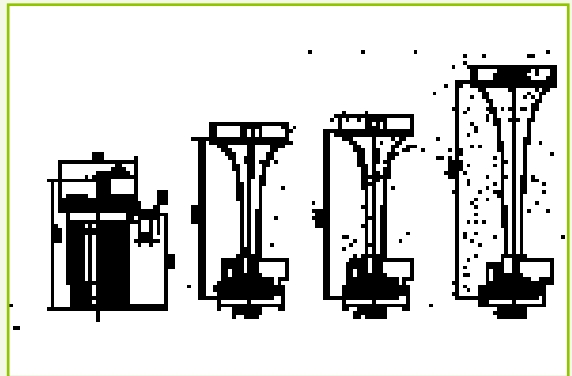

Valeo



U

I

479106

42962

(x2)

Chromed / Chromé

12 V

18A

Chromed / Chromé

12 V

18A



ELECTROPNEUMÁTICAS/ELETTROPNEUMATICO/ ELEKTROPNEMAUTYCZNY/HAVALI/Електропневматический



Hz

dB



400 +/- 10 HZ

118 db



400 +/- 10 HZ

118 db



Hz

dB



H

860+/- 43 HZ

117 db



L

650 +/- 32 HZ





117 db





AIR POWERED/ELECTROPNEUMATIQUE/ELECTRONEUMÁTICAS/
ELECTRO-PNEUMATISCH/ELEKTROPNEUMATISCH/

HYPERSONIC (.../...)

479107	49098	 (x2)		Chromed / Chromé	24 V	10A
				Chromed / Chromé	24 V	10A
479108	49094	 (x3)		Chromed / Chromé	12 V	18A
				Chromed / Chromé	12 V	18A
				Chromed / Chromé	12 V	18A
745707	42962			Black / Noir	12 V	18A

NAUTILUS

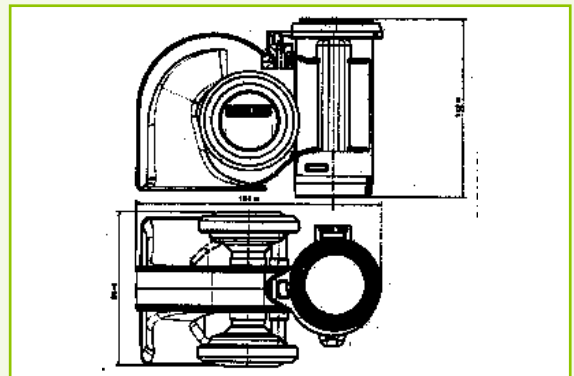

479160	00 7004			Black / Noir	12-24 V	18-9A
				Black / Noir	12-24 V	18-9A



ELECTROPNEUMÁTICAS/ELETTROPNEUMATICO/ ELEKTROPNEMAUTYCZNY/HAVALI/Електропневматический

H	770 +/- 38 HZ	117 db	
L	650 +/- 32 HZ	117 db	
H	860 +/- 43 HZ	117 db	
M	770 +/- 38 HZ	117 db	
L	650 +/- 32 HZ	117 db	



Hz

dB



H	680 +/- 34 HZ	115 db	
L	530 +/- 26 HZ	115 db	



REVERSE ALARM/ALARME DE RECUL/ALARMA DE MARCHA ATRÁS/ SEGNALATORI ACUSTICI DI RETROMARCIA/ACHTERUITRIJ ALARMEN/ GERI VITES ALARMLARI/Сигналы заднего хода



Valeo



U

I

630023

CE



Black / Noir

10-100 V

12-24A



Valeo



U

I

630024

CE



Black / Noir

10-100 V

12-24A



**INDICADORES SONOROS DE MARCHA-A-TRÁS/
RÜCKFAHRWARNER/DŹWIĘKOWE SYGNALIZATORY COFANIA/**



Hz

dB



2500 HZ

82 / 92 db



Hz

dB



2500 HZ

82 / 92 db





REVERSE ALARM/ALARME DE REcul/ALARMA DE MARCHA ATRÁS/
SEGNALATORI ACUSTICI DI RETROMARCIA/ACHTERUITRIJ ALARMEN/
GERI VITES ALARMLARI/Сигналы заднего хода

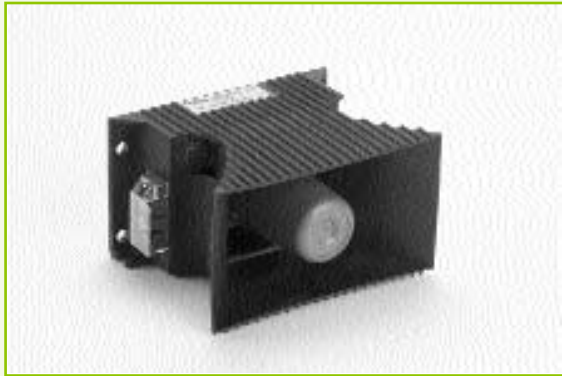

Valeo



U

I

630025

CE



Black / Noir

10-100 V

480-50A

BA87

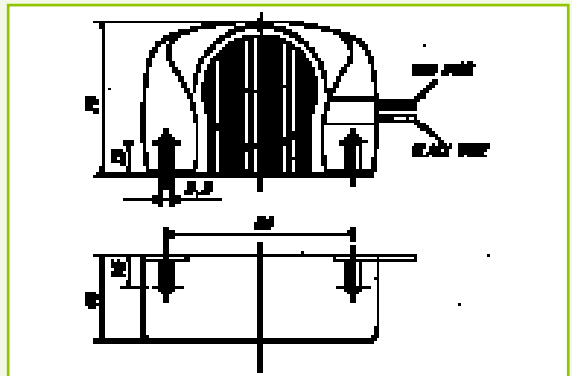

Valeo



U

I

630026

CE



Black / Noir

12-24 V

1A



**INDICADORES SONOROS DE MARCHA-A-TRÁS/
RÜCKFAHRWARNER/DŹWIĘKOWE SYGNALIZATORY COFANIA/**



Hz

dB



2500 +/-100 HZ

88 -> 110 db



Hz

dB



1500 HZ

97 db





**REVERSE ALARM/ALARME DE REcul/ALARMA DE MARCHA ATRÁS/
SEGNALATORI ACUSTICI DI RETROMARCIA/ACHTERUITRIJ ALARMEN/
GERI VITES ALARMLARI/Сигналы заднего хода**

W040

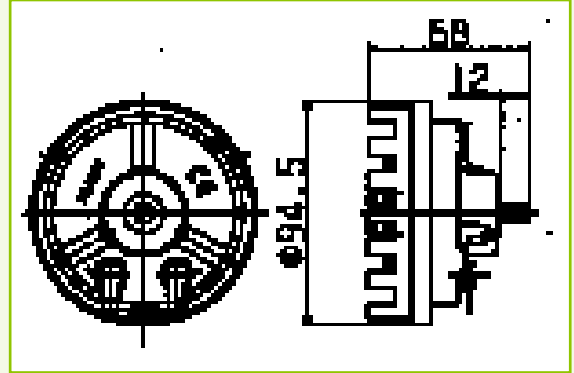

Valeo



630027

CE



Black / Noir

12-24 V

0,1A



**INDICADORES SONOROS DE MARCHA-A-TRÁS/
RÜCKFAHRWARNER/DŹWIĘKOWE SYGNALIZATORY COFANIA/**



Hz

dB



820 HZ

90 db





**EMERGENCY VEHICLE HORNS/AVERTISSEURS POUR VEHICULES PRIORITAIRES/
 SEGNALETTORI ACUSTICI DI EMERGENZA/SIRENES/SIRENEN/
 GEÇIŞ ÜSTÜNLÜKLÜ ARAÇ SIRENLERI/Сигналы для спецмашин**

ELECTRONIC/ELECTRONIQUE

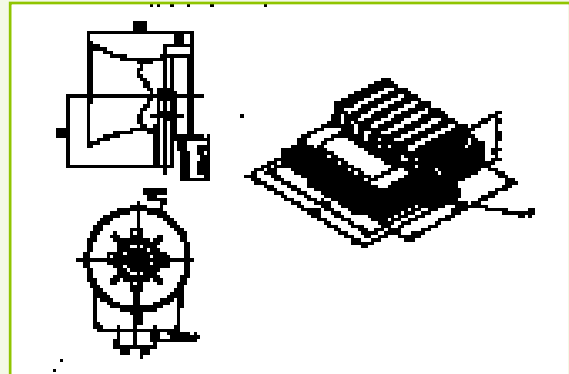

Valeo



U

I

479127	TP SPO 4001		Black / Noir	12-24 V	12V (4+/- 0,5A); 24V (2+/-0,25A)
			Black / Noir	12-24 V	15mA
479129	TP POL 4009		Black / Noir	12-24 V	
			Black / Noir	12-24 V	
479131	TP GEN 4007		Black / Noir	12-24 V	
			Black / Noir	12-24 V	
479133	TP UMH 4010		Black / Noir	12-24 V	
			Black / Noir	12-24 V	
479135	TP ASA 4006		Black / Noir	12-24 V	12V (4+/- 0,5A); 24V (2+/-0,25A)
			Black / Noir	12-24 V	15mA
			Black / Noir	12-24 V	
			Black / Noir	12-24 V	



BOCINA PARA VEHÍCULO DE EMERGENCIA/BUZINAS PARA VEÍCULOS DE EMERGÊNCIA/ SYGNAŁY DŹWIĘKOWE DLA POJAZDÓW UPZYWILEJOWANYCH/



Hz

dB



TONE/TON 1 : 435 +/-4 HZ	117 +/- 5 db	28 +/- 1 cycles / min		Pompiers	Fr
TONE/TON 2 : 488 +/-4 HZ	85 +/- 5 db	28 +/- 1 cycles / min		Pompiers	Fr
TONE/TON 1 : 435 +/-4 HZ	117 +/- 1 db	55 +/- 1 cycles / min		Police	Fr
TONE/TON 2 : 488 +/-4 HZ	85 +/- 5 db	55 +/- 1 cycles / min		Police	Fr
TONE/TON 1 : 435 +/-4 HZ	117 +/- 1 db	55 +/- 1 cycles / min		Gendarmerie	Fr
TONE/TON 2 : 732 +/-4 HZ	85 +/- 5 db	55 +/- 1 cycles / min		Gendarmerie	Fr
TONE/TON 1 : 435 +/-4 HZ	117 +/- 1 db	55 +/- 1 cycles / min		UMH	Fr
TONE/TON 2 : 651 +/-7 HZ	85 +/- 5 db	55 +/- 1 cycles / min		UMH	Fr
TONE/TON 1 : 420 +/- 4HZ	108 +/- 1 db	30 +/- 1 cycles / min		Ambulance	Fr
TONE/TON 2 : 516 +/- 5HZ		30 +/- 1 cycles / min		Ambulance	Fr
TONE/TON 3 : 420 +/- 4HZ		30 +/- 1 cycles / min		Ambulance	Fr
TONE/TON 4 : SILENCE 1,5S		30 +/- 1 cycles / min		Ambulance	Fr



**EMERGENCY VEHICLE HORNS/AVERTISSEURS POUR VEHICULES PRIORITAIRES/
 SEGNALETTORI ACUSTICI DI EMERGENZA/SIRENES/SIRENEN/
 GEÇIŞ ÜSTÜNLÜKLÜ ARAÇ SIRENLERİ/Сигналы для спецмашин**

AIR POWERED/ELECTROPNEUMATIQUE

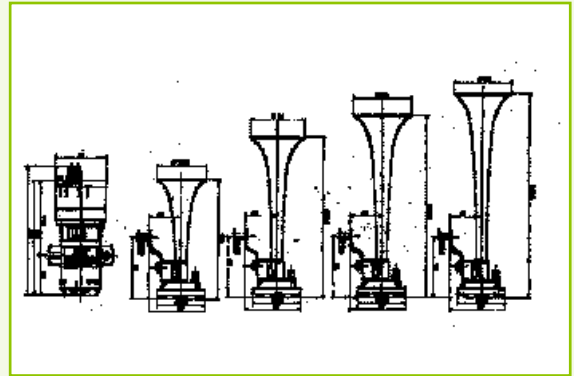

Valeo	H	TYPE	Color	U	I
069754	E3 10 R-02 7189	(x2)	Black / Noir	12 V	15A
			Black / Noir	12 V	15A
069755	88004	(x2)	Black / Noir	24 V	7,5A
			Black / Noir	24 V	7,5A
745714			Chromed / Chromé	12 V	15A
745715			Chromed / Chromé	24 V	7,5A
745811		319,5mm	Black / Noir	12-24 V	
745812		283,5mm	Black / Noir	12-24 V	
069757	E3 10 R-02 7189	(x2)	Black / Noir	12 V	15A
			Black / Noir	12 V	15A
-		182mm	Black / Noir	12-24 V	
745811		319,5mm	Black / Noir	12-24 V	



BOCINA PARA VEHÍCULO DE EMERGENCIA/BUZINAS PARA VEÍCULOS DE EMERGÊNCIA/ SYGNAŁY DŹWIĘKOWE DLA POJAZDÓW UPZYWILEJOWANYCH/



Hz

dB



TONE/TON 1 : 488 +/-2 HZ	115 db				Pompiers	Fr
TONE/TON 2 : 435 +/-2 HZ	115 db				Pompiers	Fr
TONE/TON 1 : 488 +/-2 HZ	115 db				Pompiers	Fr
TONE/TON 2 : 435 +/-2 HZ	115 db				Pompiers	Fr
					Pompiers	Fr
					Pompiers	Fr
					Pompiers	Fr
					Pompiers	Fr
TONE/TON 1 : 732 +/-2 HZ	115 db				Gendarmerie	Fr
TONE/TON 2 : 435 +/-2 HZ	115 db				Gendarmerie	Fr
					Gendarmerie	Fr
					Gendarmerie	Fr



**EMERGENCY VEHICLE HORNS/AVERTISSEURS POUR VEHICULES PRIORITAIRES/
 SEGNALATORI ACUSTICI DI EMERGENZA/SIRENES/SIRENEN/
 GEÇIŞ ÜSTÜNLÜKLÜ ARAÇ SIRENLERI/Сигналы для спецмашин**

AIR POWERED/ELECTROPNEUMATIQUE (.../...)

Valeo										
745792	E3 10 R-02 7189		(x2)			Black / Noir	12 V	15A		
						Black / Noir	12 V	15A		
745793	88005		(x2)			Black / Noir	24 V	7,5A		
						Black / Noir	24 V	7,5A		
745711						Chromed / Chromé	12 V	15A		
745712						Chromed / Chromé	24 V	7,5A		
745811					319,5mm	Black / Noir	12-24 V			
-					248,5mm	Black / Noir	12-24 V			
745797	E3 10 R-02 7189		(x2)			Black / Noir	12 V	15A		
						Black / Noir	12 V	15A		
745716						Chromed / Chromé	12 V	15A		
745811					319,5mm	Black / Noir	12-24 V			
745812					283,5mm	Black / Noir	12-24 V			



BOCINA PARA VEHÍCULO DE EMERGENCIA/BUZINAS PARA VEÍCULOS DE EMERGÊNCIA/ SYGNAŁY DŹWIĘKOWE DLA POJAZDÓW UPRZYWILEJOWANYCH/

	Hz	dB				
	TONE/TON 1 : 580 +/-2 HZ	115 db			Police	Fr
	TONE/TON 2 : 435 +/-2 HZ	115 db			Police	Fr
	TONE/TON 1 : 580 +/-2 HZ	115 db			Police	Fr
	TONE/TON 2 : 435 +/-2 HZ	115 db			Police	Fr
					Police	Fr
					Police	Fr
					Police	Fr
					Police	Fr
	TONE/TON 1 : 517 +/-2 HZ	115 db			Ambulance	Fr
	TONE/TON 2 : 420 +/-2 HZ	115 db			Ambulance	Fr
					Ambulance	Fr
					Ambulance	Fr
					Ambulance	Fr

2

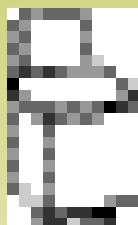

Relays

Relais

Relés

Relés

Relé



Relais

Relais





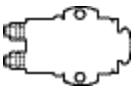

Przekaźniki







Röleler

Реле

	
	44
	80
	82



	Relay Relais Relé Relé Relé Relais Relais Przełącznik Rôle Реле
FIX.	Fixing Fixation Fijación Fixação Fissaggio Fixatie Fixierung Мосowanie Takma Крепление
	Colour Couleur Color Cör Colore Kleur Farbe Kolor Renk Цвет
	Protection Protection Protección Proteção Protezione Bescherming Schutz Chroniony Корума Защита
Classic / Classique	Classic (No protection) Classique (sans protection) Clásico Clássico Classico Classic Klassisch (ohne Schutz) Klasyczny (bez ochrony) Klasik (korumasız) Классический (без защиты)
	Resistance Resistance Resistencia Resistência Resistenza Weerstand Resistenz Opór Direnç Сопротивление
	Diode Diode Diodo Diodo Diodo Diodo Diodo Diodo Dioda Diyod Диод
	Fuse Fusible Fusible Fusível Fusibile Zekering Sicherung Bezpiecznik Sigorta Предохранитель

	Standard Terminals Norme de bornage Norma de embornado Terminais padrão Terminali standard Standaard uitgangen Standard Datenverbindung Standardowe gniazda Standart kutup Стандартный контакт
CT	Technical code Code technique Código técnico Código técnico Codice tecnico Technische code Technischer Code Kod techniczny Teknik kod Технический код
	Connector for relay Connecteur pour relais Conector para relé Ligação para relés Connettore per relé Stekkerverbinding voor relais Relaisstecker Gniazdo przełącznika Rôle bağlantısı Контакт для реле
	Complete with lugs Fourni avec cosses Suministrado con terminal Fornecido com terminal Completo di morsetti Compleet met kabelschoen Komplett mit Öse Kompletny z nóżkami Kutusu ile beraber Комплектный с соединениями
	Dimension of lugs Dimension des cosses Dimensión del terminal Dimensão do terminal Dimensione dei morsetti Dimensie van kabelschoen Ösendimension Wymiary nóżek Kutu ölçüsü Размер соединения
	Number of plugs Nombre de fiches Numero de conectores Número de ligações Numero di spine Aantal kabelschoenen Anzahl Steckverbinder Ilość podłączy Vacak sayısı Количество соединений
	High and low beam Pour faisceaux de fils Para conjunto de cables Para conjunto de cabos Per fascio di cavi Hoge- en lage lichtbundel Für Fadenbündel Światła mijania i drogowe Kısa ve uzun ışık Дальний и ближний свет
	To Weld A souder A soldar Para soldar Da saldare Lassen Zu schweissen Do lutowania Каунак Сварка

	Coil relay contact Contacteur à relais à bobine (d'appel isolée) Contactador con relé y bobina Ligação com relé e bobina Contattore a relé con bobina Relais met spoel -
Micro-relay / Micro-relais	Cewka Rôle bobin bağlantısı Катушка Micro-relay Micro-relais Micro relé Micro relé Micro-relé Micro-relais Miniaturrelais Mikro przełącznik Mikro rôle Микро реле
Cubic relay / Relais cubique	Cubic relay Relais cubique Relé cúbico Relé cúbico Relé cubici Kubusvormig-relais Würfel Relais Przełącznik kostkowe Küçük rôle Кубические реле
Power relay / Relais de puissance	Power relay Relais de puissance Relé de potencia Relé de potência Relé di potenza Bekrachtigingsrelais Leistungsrelais Przełącznik mocy Yüksek güç röleleri Высокоэффективные реле
Contact / Contacteur	Contact Contacteur Contactador Contactore Contact Kontakt Złącze Kontak bağlantı Контакт
Double contact / Double contacteur	Double Contact Double contacteur Doble contactor Contactador duplo Doppio contattore Dubbel contact Doppelkontakt Złącze podwójne Çift kontaklı bağlantı Двойной контакт
Reverser / Inverseur	Reverser Inverseur Inversor Inversor Invertitore Reverser Umschalter Zwrotny Çevirici Возвратный
Functioning / Fonctionnement	Functioning Fonctionnement Funcionamiento Funcionamento Funcionamento Funcionering Funktion Funkcjonowanie I_levsellik Действование



Permanent / Permanent	Permanent Permanent Permanente Permanente Permanent Permanent Stały Kalıcı Постоянный	Brown / Marron	Brown Marron Marrón Castanho Marrone Kastanje Kastanie Brązowy Kahverengi Бронзовый	For power relay / Pour relais de puissance For power relay Pour relais de puissance Para relé de potencia Relé de potência Per relé di potenza Bekrachtigingsrelais Leistungsrelais Przekaznik mocy Yüksek güç röleleri Высокоэффективные реле
Closed / Fermé	Closed Fermé Cerrado Fechado Chiuso Gesloten Geschlossen Zamknięty Kapalı Закрыт	Green / Vert	Green Vert Verde Verde Verde Groen Grün Zielony Yeşil Зелёный	
Opened / Ouvert	Opened Ouvert Abierto Aberto Aperto Geopent Geöffnet Otwarty Açık Открыт	Grey / Gris	Grey Gris Gris Cinzento Grigio Grijs Grau Szary Gri Серый	
Conjunction voltage / Tension de conjunction	Conjunction voltage Tension de conjunction Tensión de conjunción Tensão de conjugação Tensione di connessione Verbindungsspannung Schaltspannung Napięcie połączenia Bağlantı gerilimi Напряжение соединения	Purple / Violet	Purple Violet Violeta Violeta Viola Paars Violet Fioletowy Mor Фиолетовый	
Consumption under tension (cold) / Consommation bobine sous U à froid	Consumption under tension (cold) Consommation sous tension (U) à froid Consumo bajo tensión (U) en frío Consumo em tensão (U) a frio Consumo sotto tensione (U) a freddo Verbruik (koud) Verbrauch (kalt) Zużycie napięcia (U) Gerilim (U) altında tüketim (soğuk) Расход напряжения (U)	Yellow / Jaune	Yellow Jaune Amarillo Amarelo Tuorlo Geel Gelb Żółty Sarı Жёлтый	
Nominal voltage / Tension nominale	Nominal voltage Tension nominale Tensión nominal Tensão nominal Tensione nominale Nominale spanning Nominalspannung Napięcie nominalne Nominal gerilim Напряжение номинальное	Red / Rouge	Red Rouge Rojo Vermelho Rosso Rood Rot Czerwony Kırmızı Красный	
Black / Noir	Black Noir Negro Preto Nero Zwart Schwarz Czarny Siyah Чёрный	For micro-relay / Pour micro-relais	For micro-relay Pour micro-relais Para micro relé Micro relé Per micro-relé Micro-relais Miniaturrelais Mikro przekaznik Mikro röle Микро реле	
Blue / Bleu	Blue Bleu Azul Azul Blu Blauw Blau Niebieski Mavi Голубой	For cubic relay / Pour relais cubique	For cubic relay Pour relais cubique Para relé cúbico Relé cúbico Per relé cubici Kubusvormig-relais Würfel Relais Przekaznik kostkowe Kúbik röle Кубические реле	



- GB** : Before replacing a relay, you must identify:
FR : Avant de remplacer un relais, il faut identifier :
ES : Antes de sustituir un relé, es preciso identificar:
PT : Antes de substituir um relé, é necessário identificar :
IT : Prima di sostituire un rele, occorre identificare :
NL : Voor vervanging van een relay, moet het volgende geïdentificeerd zijn :
DE : Bevor ein Relais ausgetauscht wird muss bestimmt werden :
PL : Przed wymianą przekaźnika trzeba zidentyfikować :
TR : Röle değiştirilmeden önce tanımlanmalıdır :
RU : Перед обменной надо узнать :

1

U = Tension/Tension/Tensión/Tensão/Tensione/Spanning/Spannung/Napięcie/ Gerilim/Напряжение

- 12V
- 24V

2

I = Amp Draw/Intensité/Intensidad/Intensidade/Intensità/Intensiteit/ Stromaufnahme/Natężenie/Şiddet/Интенсивность

- = Must be replaced with
 Doit être remplacé par
 Debe ser remplazado por
 Deve ser substituído por
 Deve essere sostituito con
 Moet vervangen worden door
 Muss ausgetauscht werden mit
 Musi być wymieniany z
 Şununla değiştirilmelidir
 Нужно менять вместе с

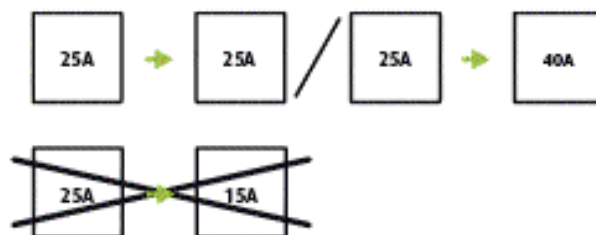

3

The type of relay/Le type de relais/El tipo de relé/O tipo de relé/Il tipo di relé/ De type relay/Der RelaisTyp/Typ przekaźnika/Röle tipi/Тип реле

Micro-relay
 Micro-relais
 Micro relé
 Micro relé
 Micro-relé

Micro-relais
 Mikrorelais
 Micro przekaźnik
 Mikro röle
 Микро реле

≈ 0A ≤ I ≤ 25A

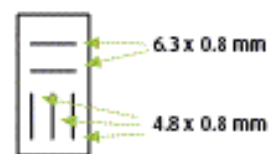

Cubic relay
 Relais cubique
 Relé cúbico
 Relé cúbico
 Relé cubico

Kubusvormig-relais
 Würfel Relais
 Przekaznik kostkowiec
 Kúbik röle
 Кубические реле

≈ 20A ≤ I ≤ 50A

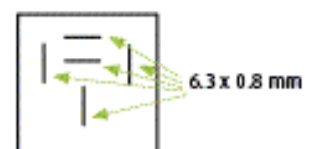

Power relay
 Relais de puissance
 Relé de potencia
 Relé de potência
 Relé di potenza

Relais voor hoge prestatie
 Hochleistungsrelais
 Przekaznik dużej mocy
 Par yüksek güç röleleri
 Высокоэффективные реле

≈ I ≥ 40A

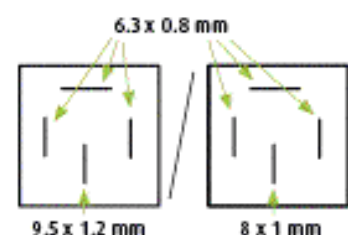

**The type of configuration/Le type de configuration/El tipo de configuración/
O tipo de configuração/Il tipo di configurazione/De Type configuratie/
Der Konfigurationstyp/Тип конфигурації/Birleşim tipi/Тип конфигурации**

Contact relay (T),
Le relais contacteur (T),
El relé contactor (T),
O relé de contacto (T),
Il relé contattore (T),
De contact relais (T),
Das Kontaktrelais (T),
Przełącznik z kontaktem (T),
Bağlantı rölesi (T),
Реле с контактом (T),

to activate only 1 function:
pour activer 1 seule fonction :
para activar 1 sola función:
para activar 1 função :
per attivare 1 sola funzione :
activeren van 1 functie :
nur 1 Funktion aktivieren :
do aktywowania tylko 1 funkcji :
Sadece bir işlevi çalıştırmak için :
Для включения только 1 функции :

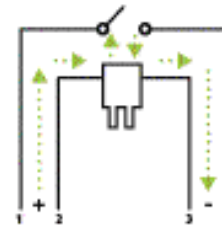

Double contact relay (2T),
Le relais double contacteur (2T),
El relé de doble contactor (2T),
O relé de duplo contacto (2T),
Il relé doppio contatto (2T),
De dubbele contact relais (2T),
Das Doppelkontaktrelais (2T),
Przełącznik z podwójnym kontaktem (2T),
Çift bağlantılı röle (2T),
Реле с двойным контактом (2T),

to activate 2 functions simultaneously:
pour activer 2 fonctions simultanément :
para activar 2 funciones simultaneamente:
para activar 2 funções em simultâneo :
per attivare 2 funzioni simultaneamente :
activeren van 2 functies tegelijkertijd :
2 Funktionen gleichzeitig aktivieren :
do aktywowania 2 funkcji równocześnie :
iki işlevi aynı anda çalıştırmak için :
Для включения 2 функций одновременно :

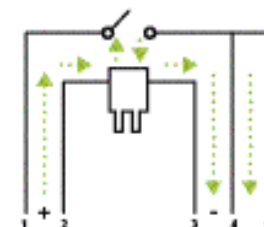

Double contact relay (2x1T),
Le relais double contacteur (2x1T),
El relé de doble contactor (2x1T),
O relé de duplo contacto (2x1T),
Il relé doppio contatto (2x1T),
De dubbele contact relais (2x1T),
Das Doppelkontaktrelais (2x1T),
Przełącznik z podwójnym kontaktem (2x1T),
Çift bağlantılı röle (2x1T),
Реле с двойным контактом (2x1T),

to activate 2 functions separately:
pour activer 2 fonctions séparément :
para activar 2 funciones por separado :
para activar 2 funções separadas :
per attivare 2 funzioni separatamente :
2 functies apart activeren :
2 Funktionen einzeln aktivieren :
do aktywowania 2 funkcji oddzielnie :
iki işlevi bağımsız olarak çalıştırmak için :
Для включения 2 функций отдельно :

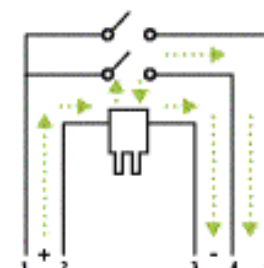

Reverse relay,
Le relais inverseur,
Los relés inversores,
Os relés inversores,
Il relé invertitore,
De wissel relais,
Das Umkehrrelais,
Przełącznik zwrotny,
Dönüştürücü röle,
Реле возвратный,

to activate 1 or several functions : Rest (1) or Work (2):
pour activer 1 ou plusieurs fonctions selon 2 modes différents : Repos (1) ou Travail (2) :
para activar 1 o varias funciones según 2 modos diferentes : Reposo (1) o Trabajo (2) :
para activar 1 ou várias funções segundo 2 modos diferentes : Repouso (1) ou Trabalho (2) :
per attivare 1 o più funzioni in 2 modi differenti : Riposo (1) o Attivo (2) :
het activeren van diverse functies : Rust (1) of Werken (2) :
1 oder verschiedene Funktionen nach 2 Methoden aktivieren : Pause (1) oder Arbeit (2) :
do aktywowania 1 lub kilku funkcji : Przerwa (1) lub Praca (2) :
bir ya da çok işlevi iki şekilde çalıştırmak için : Kapalı (1) veya Açık (2) :
Для включения 1 или нескольких функций : Перерыв (1) или Работа (2) :

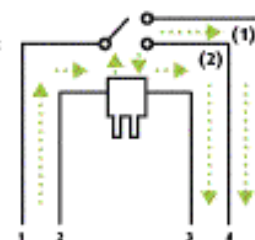

5

The relay protection/La protection du relais/La protección del relés/ A protecção do relé/La protezione del relé/De Relay bescherming/Der Relaisschutz/ Do ochrony przekaźnika/Röle koruması/Защита реле

- The relay protection is necessary to decrease as much as possible the tension peaks (U) in the loaded vehicle electronic modules, which can damage electronic controls such as calculators.
- La protection d'un relais a pour but de réduire au maximum les pics de tension (U) qui s'effectuent dans les modules électroniques embarqués du véhicule et qui peuvent endommager les organes électroniques comme les calculateurs.
- La función de un relé consiste en reducir los picos de tensión (U) que se producen en los módulos electrónicos del vehículo y que pueden averiar órganos como las centralitas electrónicas.
- A protecção de um relé é necessária para reduzir os picos de tensão (U) que se produzem no módulos electrónicos do veículo e que podem avariar órgãos como unidades de controlo electrónicas.
- La protezione del relé ha lo scopo di ridurre al massimo i picchi di tensione (U) che derivano dai moduli elettronici del veicolo e che possono danneggiare gli apparecchi elettronici come i computer di bordo.
- De relais bescherming is nodig om de spanningspieken terug te brengen in het geladen voertuig, welke andere elektronische apparaten kan beschadigen.
- Der Relaisschutz ist notwendig um Spannungsspitzen an vorhandenen Elektronikbauteilen (z.B. Steuergeräten) des Fahrzeugs zu vermeiden.
- Ochrona przekaźnika jest niezbędna do zredukowania do minimum możliwości skoków napięcia (U) w zasilanych modułach pojazdu, jakie mogą zniszczyć elektroniczne odbiorniki jak np. zegarki.
- Aracın yol bilgisayarı ve sayacılar gibi elektronik donanımları ağır voltaj hareketlerinden (U) korumak için röle koruması gereklidir.
- Защита реле необходима для уменьшения возможности увеличения напряжения (U) в заряжаемых модулях автомобиля, может оно испортить электронные приёмники, например часы.

U	Classic Classique Clásico Clássico Classico Classic Klassisch Klasyczny Klasik Классический	Resistance A résistance Con resistencia Com resistència A resistenza Met weerstand Beständigkeit Z opornikiem Dirençli röle С реостатом	Diode A diode Con diodos Com diodos A diodi Met diode Diode Z diodą Diyod ile С диодой
180V	180V	90V	5V

→ = Must be replaced with
Doit être remplacé par
Debe ser remplazado por
Deve ser substituído por
Deve essere sostituito con

Moet vervangen worden door
Muss ausgetauscht werden mit
Musi być wymieniany z
Şununla değiştirilmelidir
Нужно менять вместе с



Classic (no protection)
 Classique (sans protection)
 Clásico (sin protección)
 Clássico (sem protecção)
 Classico (senza protezione)

Classic (zonder bescherming)
 Klassisch (ohne Schutz)
 Klasyczny (bez ochrony)
 Klasik (копматасц)
 Классический (без защиты)

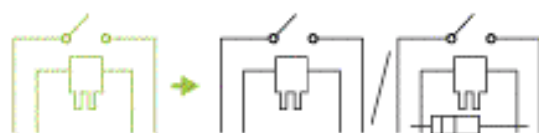

Resistance
 A Résistance
 Con resistencia
 Com resistència
 A resistenza

Met weerstand
 Beständigkeit
 Z opromikiem
 Dirençli rölè
 С реостатом



Diode
 A diode
 Con diodos
 Com diodos
 A diodi

Met diode
 Diode
 Z diodą
 Diyod ile
 С диодой



! The diode polarity must be respected/Il faut toujours tenir compte de la polarité de la diode/Es preciso tener en cuenta la polaridad del diodo/E preciso ter em conta a polaridade do diodo/Bisogna rispettare la polarità del diodo/De diode polariteit moet gespecteerd worden/Die Polarität der Diode muss beachtet werden/Важновмість діоду musi być przestrzegana/Diyod kutuplanına uyumludur/Поларність діода необхідно предострагати

Fuse
 A fusible
 Con fusibles
 Com fusíveis
 A fusibile

Met zekering
 Sicherung
 Z bezpiecznikiem
 Sigorta ile
 С предохранителем



6

Standard Terminals/Norme de bornage/Norma de embornado/Terminais padrão/
 Terminali standard/Standaard uitgangen/Standard Datenverbindung/
 Standardowe gniazda/Standart kutup/Стандартный контакт

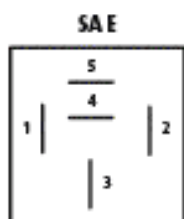
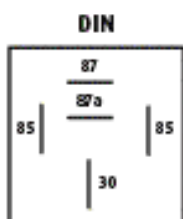

Compatibility DIN / SAE
 Compatibilité DIN / SAE
 Compatible DIN / SAE
 Compative DIN / SAE
 Compatibilità DIN/SAE
 Verglijkbare DIN / SAE
 DIN/SAE Norm
 Zgodność DIN/SAE
 DIN / SAE normlanna uyumludur
 Соответственно DIN/SAE

DIN	SAE
30	3
85	2
86	1
87	5
87 a	4





12V

MICRO-RELAY /
MICRO-RELAIS

CUBIC RELAY /
RELAIS CUBIQUE

POWER RELAY /
RELAIS DE PUISSANCE

Classic / Classique	643829 (T) 643832 (RT) 643833 (RT)	643501 (RT) / 643508 (RT) 643518 (RT) / 643601 (T) 643608 (T) / 643658 (T) 643815 (RT) / 643835 (T) 643836 (T) / 643840 (2T) 643843 (2T) / 643850 (RT) 643852 (RT) / 643853 (RT)	643856 (T)
Resistance / Résistance 	643823 (T) 643824 (RT) 643830 (T)	643510 (RT) / 643810 (2T) 643818 (RT) / 643841 (2T) 643844 (2T) / 643845 (2T) 643847 (2x1T) / 643851 (RT)	643819 (T) 643827 (T) 643855 (T)
Diode/ Diode 	643825 (RT)	643512 (RT) / 643837 (T) 643838 (T) / 643839 (T) 643848 (T) / 643849 (RT) 643854 (RT)	
Fuse/ Fusible 		643820 (2T) 643846 (2T)	

24V

MICRO-RELAY /
MICRO-RELAIS

CUBIC RELAY /
RELAIS CUBIQUE

POWER RELAY /
RELAIS DE PUISSANCE

Classic / Classique	643831 (RT) 643834 (RT)	643523 (RT) 643822 (RT)	643828 (T)
Resistance / Résistance 		643842 (2T)	
Diode / Diode 	643826 (RT)	643813 (RT)	
Fuse / Fusible 			



MICRO-RELAY/MICRO-RELAIS/MICRO RELÉ/MICRO RELÉ/MICRO-RELÉ/MICRO-RELAIS/

CONTACT / CONTACTEUR (T)

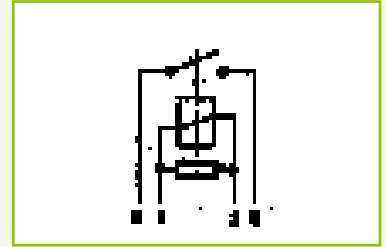
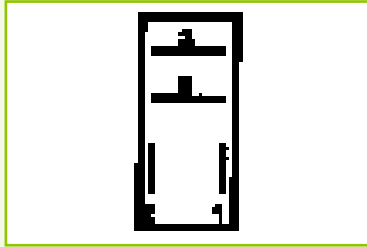

Valeo



U

I

643823

SAE

4

Black / Noir

12 V

25 A

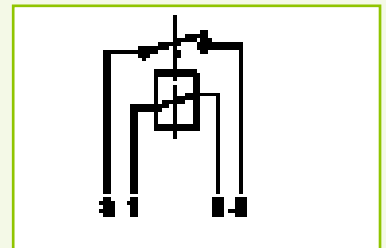
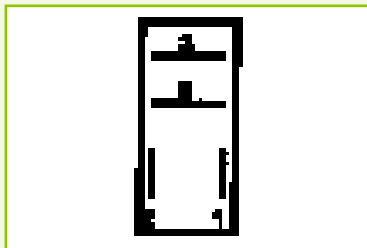

Valeo



U

I

643829

SAE

4

Black / Noir

12 V

25 A

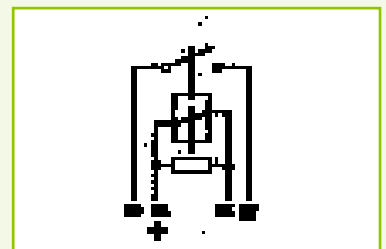

Valeo



U

I

643830

DIN

4

Black / Noir

12 V

20 A

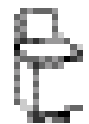

MINIATURELAIIS/MIKRO PRZEKAZNIK/MIKRO RÖLE/Микро реле

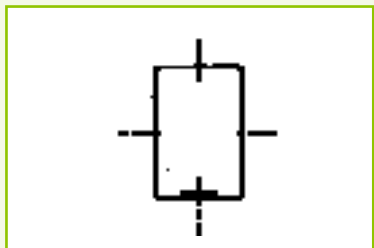
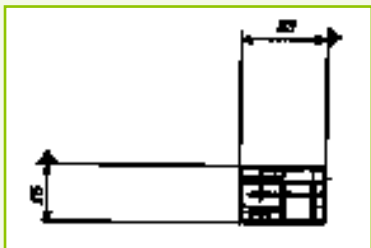
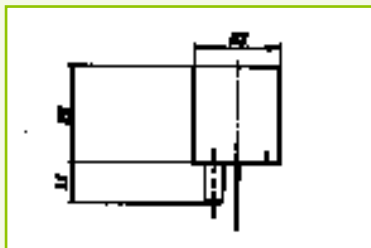

FIX.

CT



(-)

29200075

OPEL/...

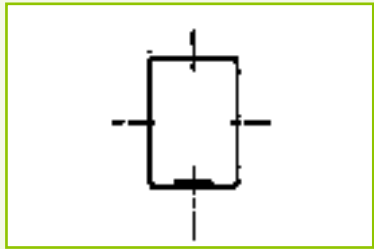
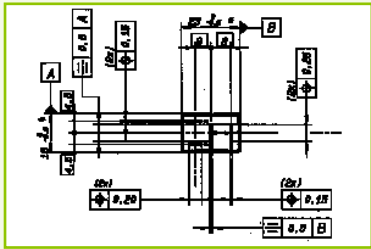
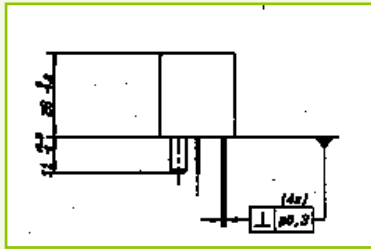

FIX.

CT



(-)

(-)

29200006

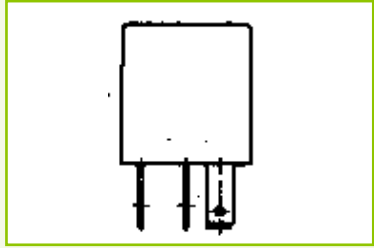
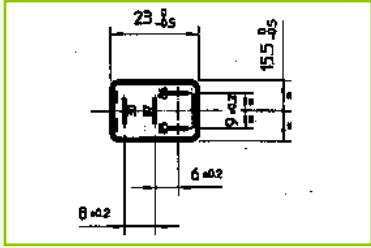
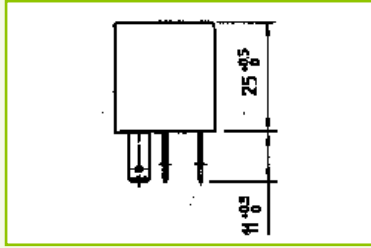

FIX.

CT



(-)

0170282



MICRO-RELAY/MICRO-RELAIS/MICRO RELÉ/MICRO RELÉ/MICRO-RELÉ/MICRO-RELAIS/

REVERSER / INVERSEUR (RT)

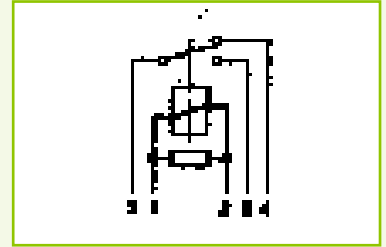
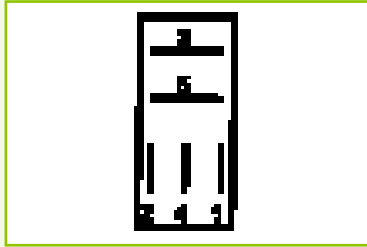

Valeo



U

I

643824

SAE

5

Black / Noir

12 V

15/25 A

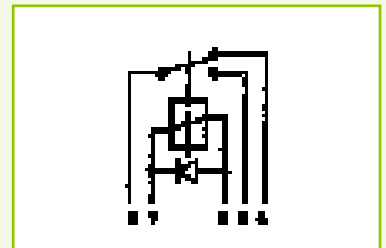
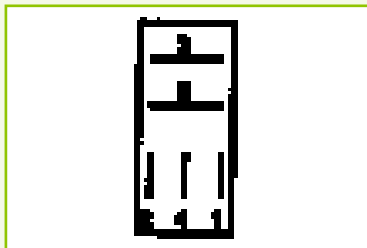

Valeo



U

I

643825

SAE

5

Black / Noir

12 V

15/25 A

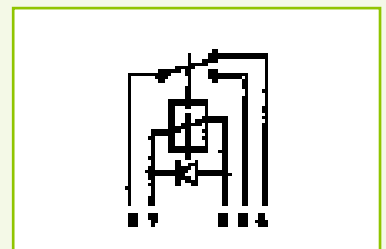
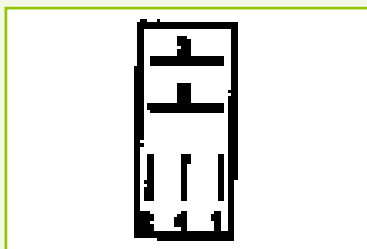

Valeo



U

I

643826

SAE

5

Black / Noir

24 V

5/10 A



MINIATURELAIIS/MIKRO PRZEKAZNIK/MIKRO RÖLE/Микро реле

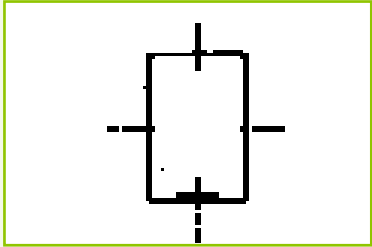
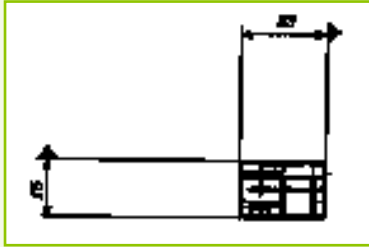
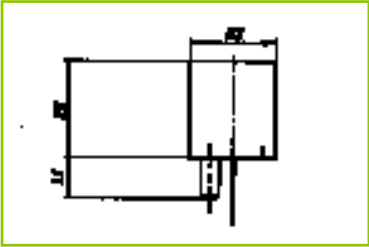

FIX.

CT



(-)

29201075

RENAULT/...

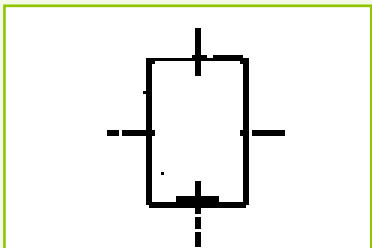
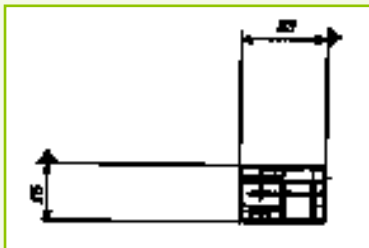
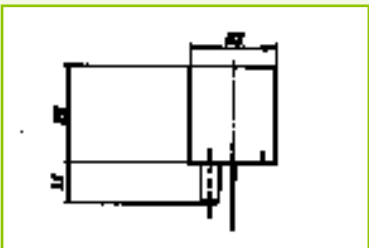

FIX.

CT



(-)

29201045

PSA/...

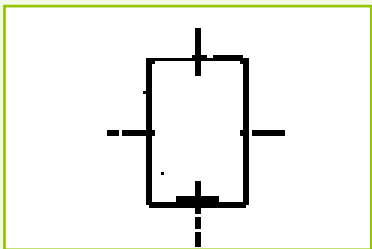
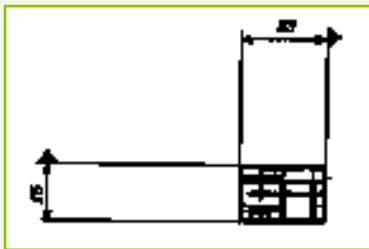
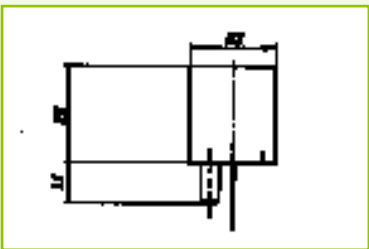

FIX.

CT



(-)

29401041



MICRO-RELAY/MICRO-RELAIS/MICRO RELÉ/MICRO RELÉ/MICRO-RELÉ/MICRO-RELAIS/

REVERSER / INVERSEUR (RT) (.../...)

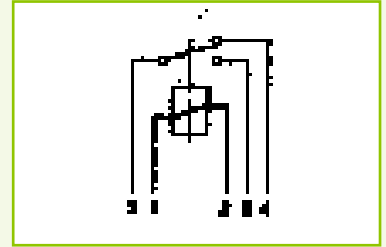
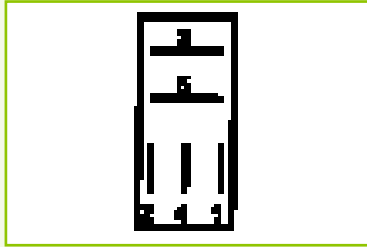

Valeo



U

I

643831

SAE

5

Black / Noir

24 V

5/10 A

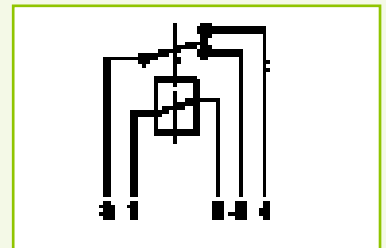
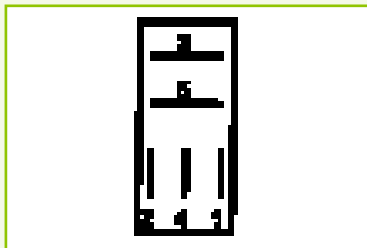

Valeo



U

I

643832

SAE

5

Black / Noir

12 V

10/20 A

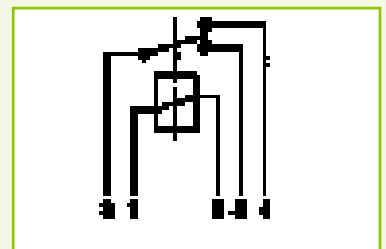
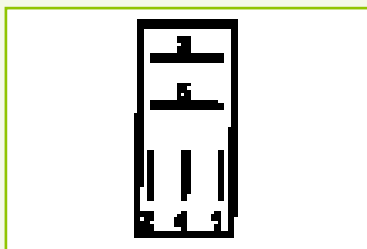

Valeo



U

I

643833

SAE

5

Black / Noir

12 V

15/25 A



MINIATURELAIIS/MIKRO PRZEKAZNIK/MIKRO RÖLE/Микро реле

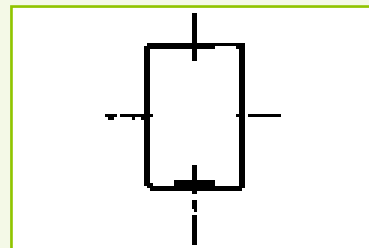
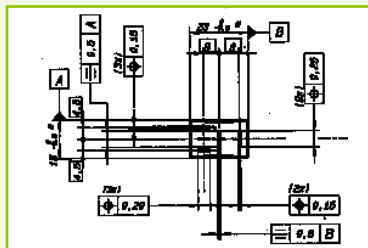
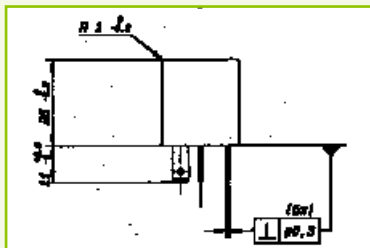

FIX.

CT



(-)

(-)

29401000

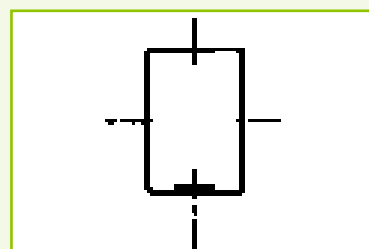
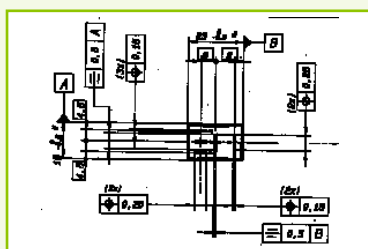
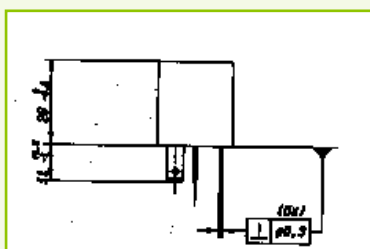

FIX.

CT



(-)

(-)

29201005

RENAULT/...

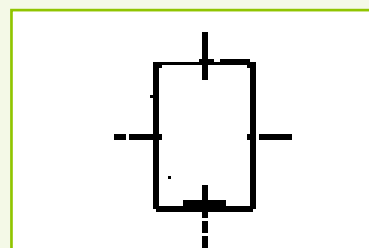
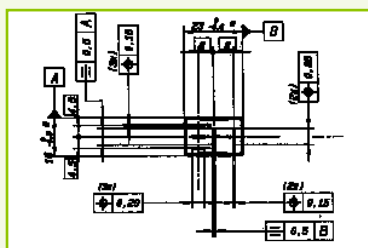
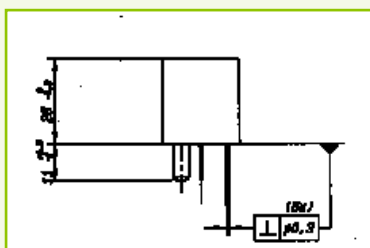

FIX.

CT



(-)

(-)

29201004



MICRO-RELAY/MICRO-RELAIS/MICRO RELÉ/MICRO RELÉ/MICRO-RELÉ/MICRO-RELAIS/

REVERSER / INVERSEUR (RT) (.../...)

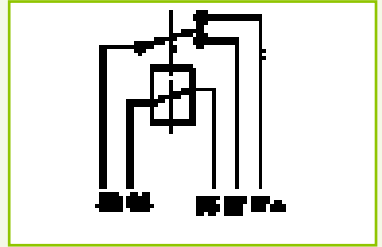
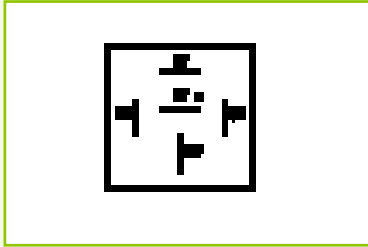

Valeo



U

I

643834

DIN

5

Grey / Gris

24 V

10/20 A



MINIATURELRAIS/MIKRO PRZEKAZNIK/MIKRO RÖLE/Микро реле



FIX.

CT



(-)

(+)

0170020



CUBIC RELAY/RELAIS CUBIQUE/RELÉ CÚBICO/RELÉ CÚBICO/RELÉ CUBICI/

CONTACT / CONTACTEUR (T)

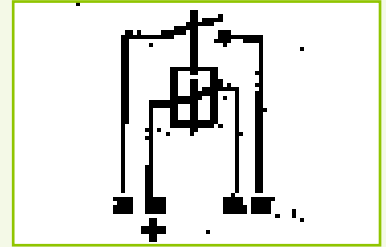
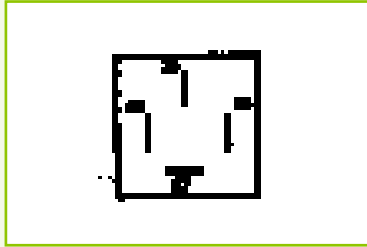

Valeo



U

I

643601

DIN

4

Green / Vert

12 V

25 A

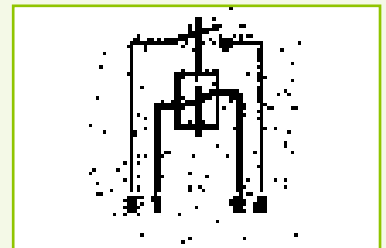
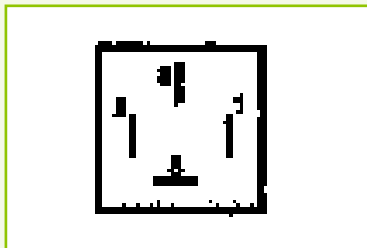

Valeo



U

I

643608

SAE

4

Green / Vert

12 V

25 A

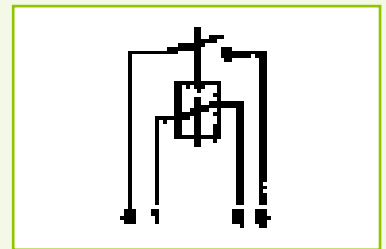
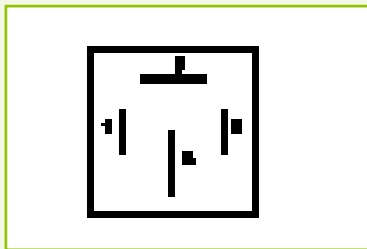

Valeo



U

I

643658

SAE

4

Green / Vert

12 V

50 A



KUBUSVORMIG-RELAIS/WÜRFEL RELAIS/PRZEKAŹNIK/KÜBIK RÖLE/Реле

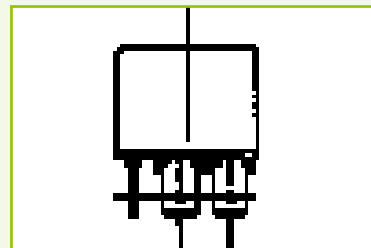
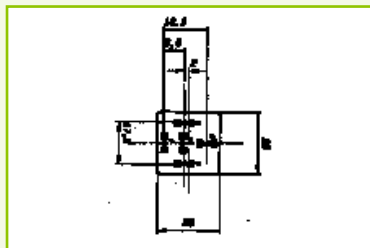
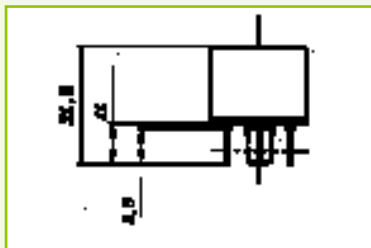

FIX.

CT



(-)

(-)

03601

PSA/...

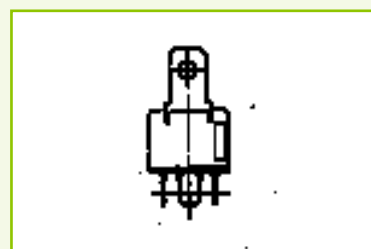
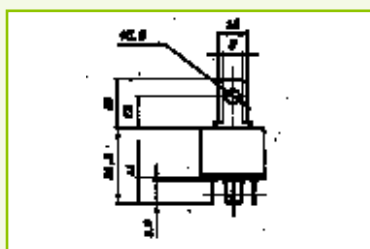
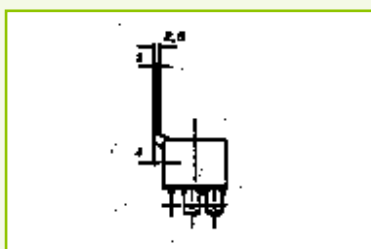

FIX.

CT



(-)

(+)

03608

PSA/...

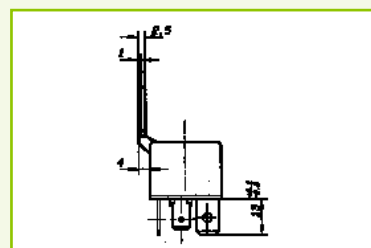
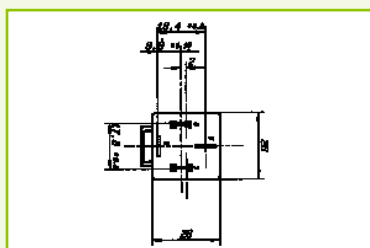
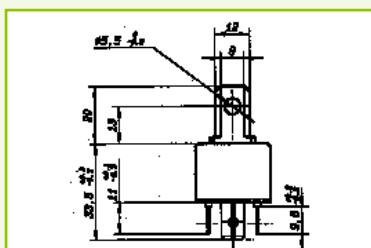

FIX.

CT



(-)

(+)

03658

PSA / RENAULT/...



CUBIC RELAY/RELAIS CUBIQUE/RELÉ CÚBICO/RELÉ CÚBICO/RELÉ CUBICI/

CONTACT / CONTACTEUR (T) (.../...)

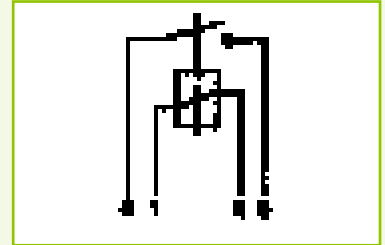
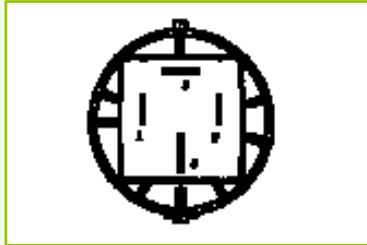

Valeo



U

I

643835

SAE

4

Grey / Gris

12 V

45 A

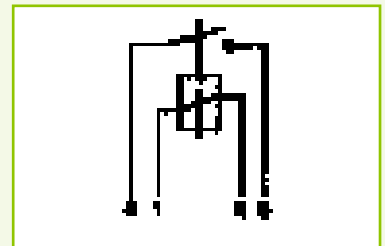
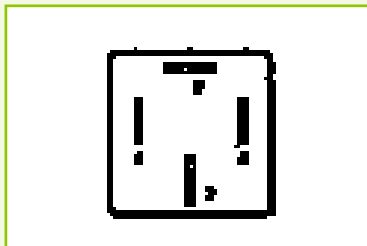

Valeo



U

I

643836

SAE

4

Grey / Gris

12 V

50 A

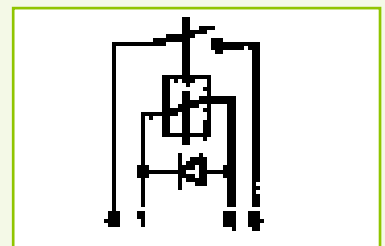
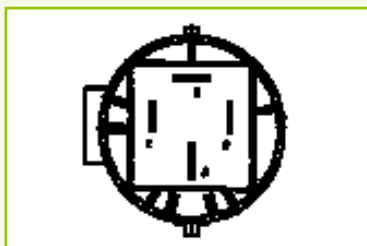

Valeo



U

I

643837

SAE

4

Purple / Violet

12 V

50 A



KUBUSVORMIG-RELAIS/WÜRFEL RELAIS/PRZEKAŹNIK/KÜBIK RÖLE/Реле

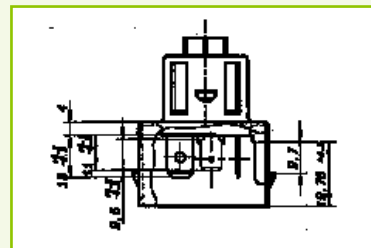
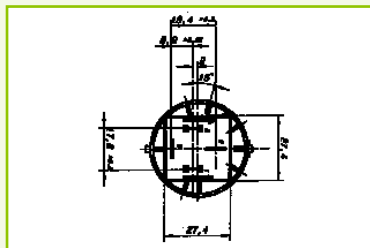
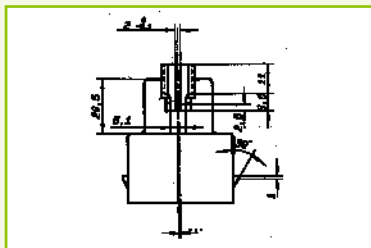

FIX.

CT



(-)

(-)

03652

PSA/...

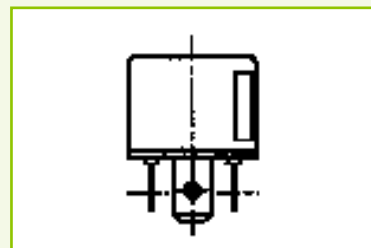
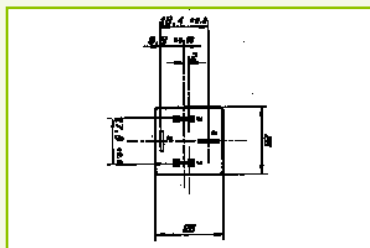
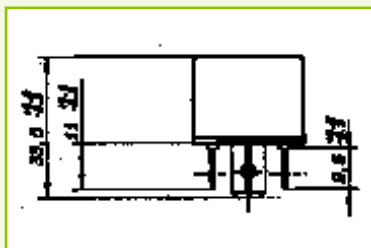

FIX.

CT



(-)

(-)

03656

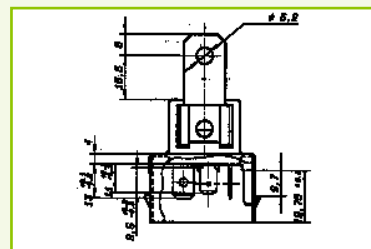
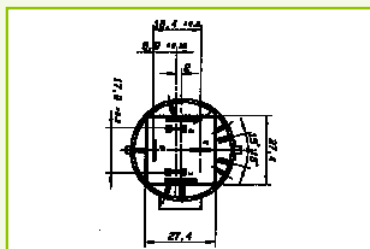
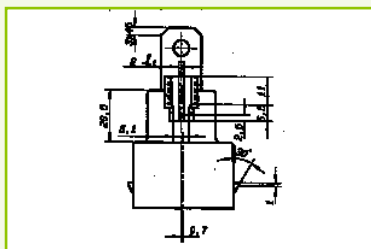

FIX.

CT



(+)

03530



CUBIC RELAY/RELAIS CUBIQUE/RELÉ CÚBICO/RELÉ CÚBICO/RELÉ CUBICI/

CONTACT / CONTACTEUR (T) (.../...)

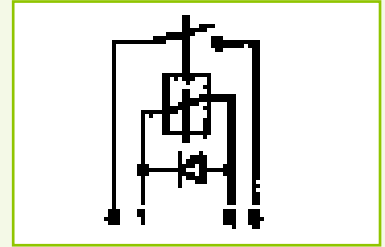
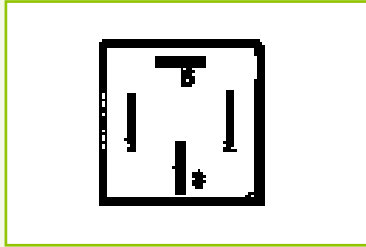

Valeo



U

I

643838

SAE

4

Purple / Violet

12 V

50 A

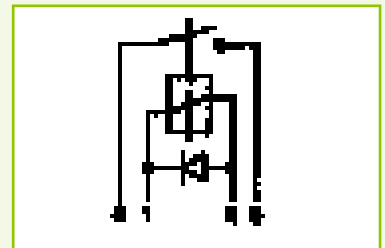
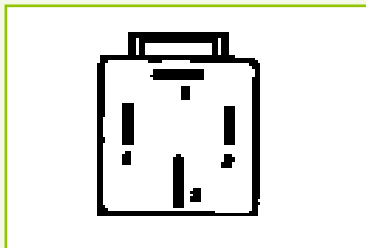

Valeo



U

I

643839

SAE

4

Purple / Violet

12 V

50 A

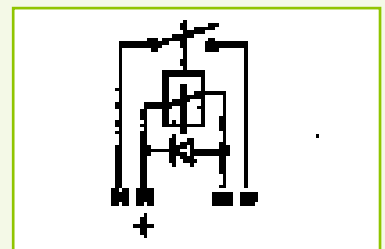
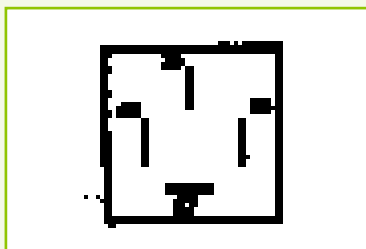

Valeo



U

I

643848

DIN

4

Yellow / Jaune

12 V

40 A



KUBUSVORMIG-RELAIS/WÜRFEL RELAIS/PRZEKAŹNIK/KÜBIK RÖLE/Реле

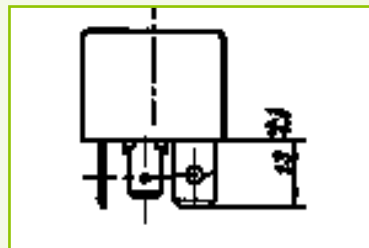
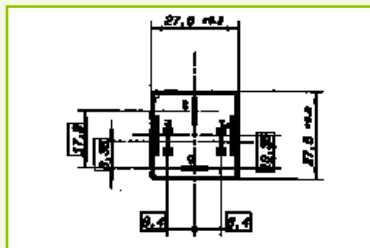
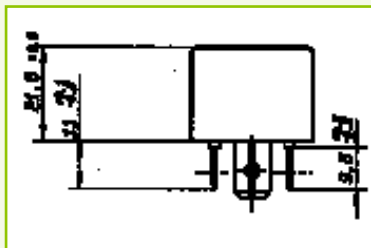

FIX.

CT



(-)

03525

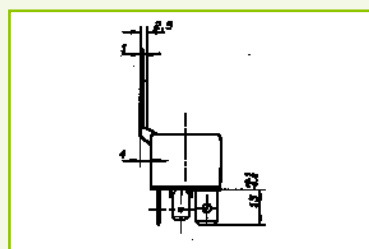
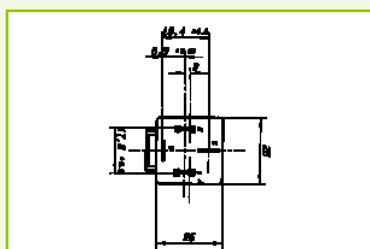
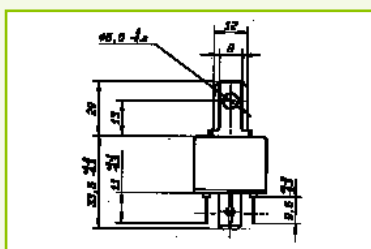

FIX.

CT



(+)

03520

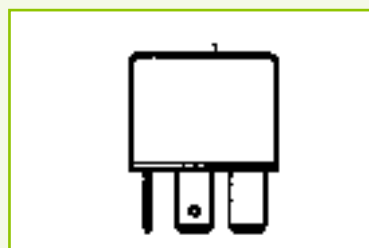
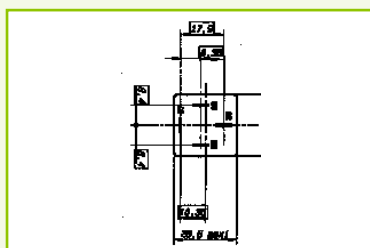
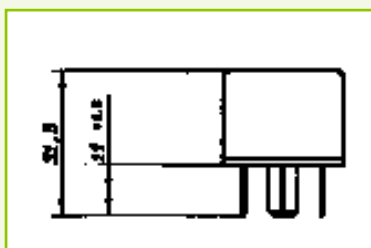

FIX.

CT



(-)

03544

PEUGEOT / RENAULT/...



CUBIC RELAY/RELAIS CUBIQUE/RELÉ CÚBICO/RELÉ CÚBICO/RELÉ CUBICI/

DOUBLE CONTACT / DOUBLE CONTACTEUR (2T)

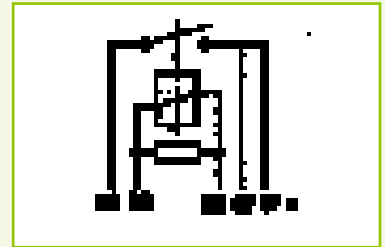
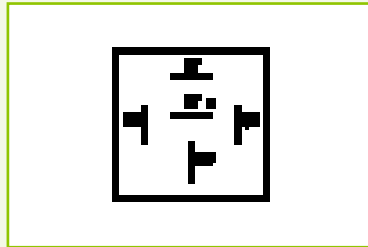

Valeo



U

I

643810

DIN

5

Yellow / Jaune

12 V

25 A

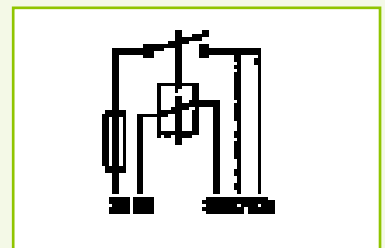
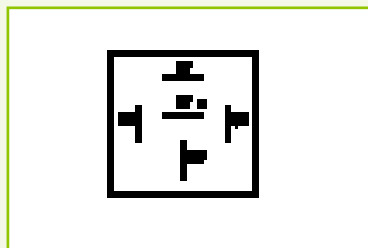

Valeo



U

I

643820

DIN

5

Black / Noir

12 V

15 A

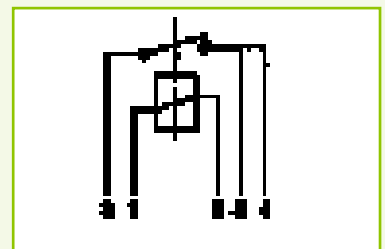
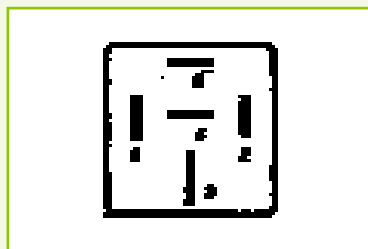

Valeo



U

I

643840

SAE

5

Yellow / Jaune

12 V

25 A

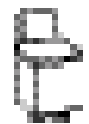

KUBUSVORMIG-RELAIS/WÜRFEL RELAIS/PRZEKAŹNIK/KÜBIK RÖLE/Реле

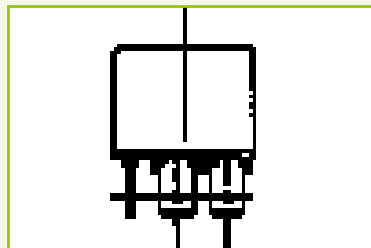
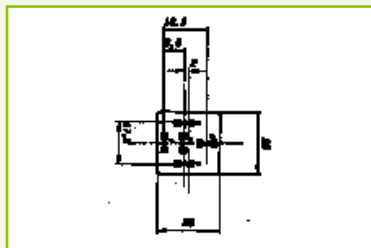
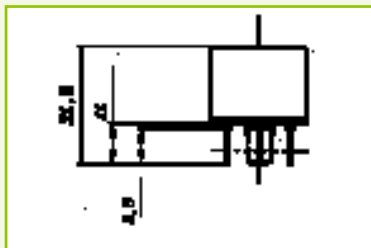

FIX.

CT



(-)

03701

PSA/...



FIX.

CT



(+)

0160940

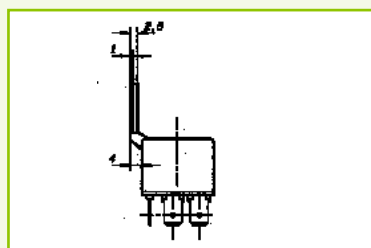
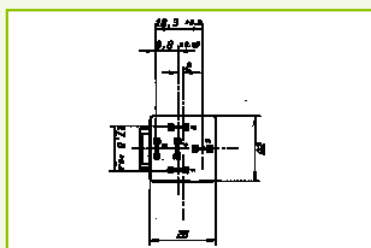
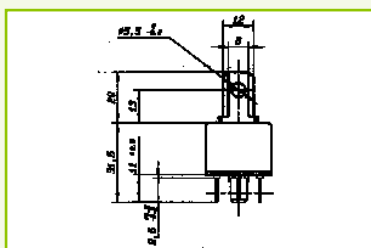

FIX.

CT



(-)

(+)

03702



CUBIC RELAY/RELAIS CUBIQUE/RELÉ CÚBICO/RELÉ CÚBICO/RELÉ CUBICI/

DOUBLE CONTACT / DOUBLE CONTACTEUR (2T)

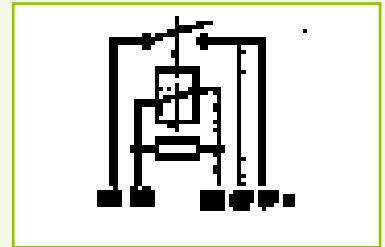
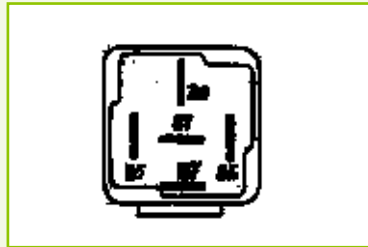

Valeo



U

I

643841

DIN

5

Green / Vert

12 V

2x15 A

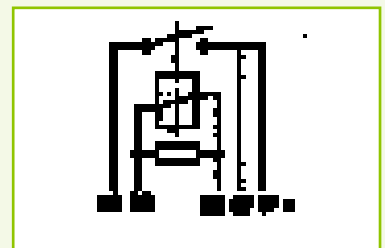

Valeo



U

I

643842

DIN

5

Black / Noir

24 V

40 A

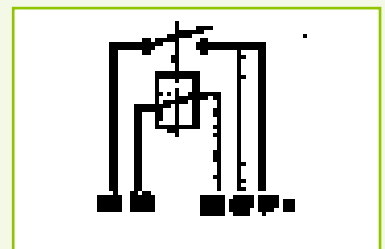
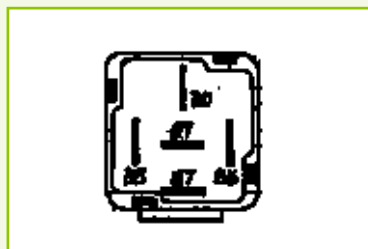

Valeo



U

I

643843

DIN

5

Brown / Marron

12 V

2x15 A



KUBUSVORMIG-RELAIS/WÜRFEL RELAIS/PRZEKAŹNIK/KÜBIK RÖLE/Реле

(.../...)

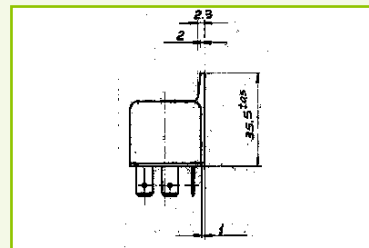
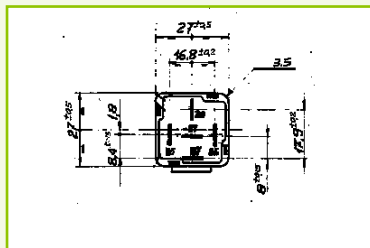
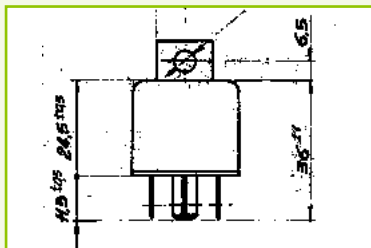

FIX.

CT



(+)

0103700

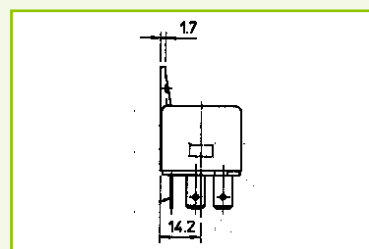
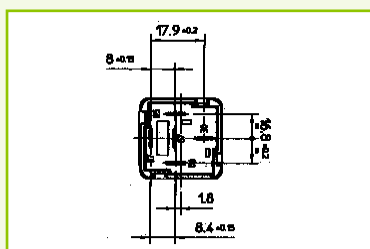
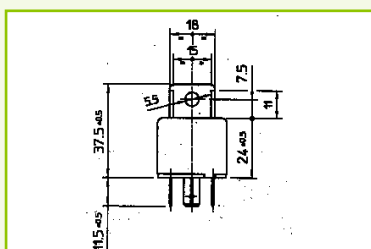

FIX.

CT



(+)

0104300

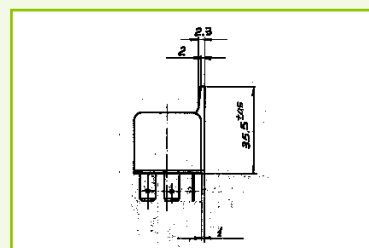
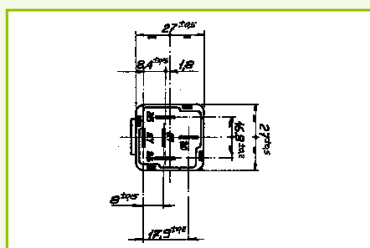
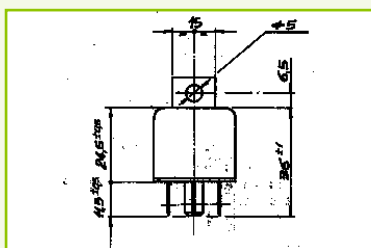

FIX.

CT



(-)

(+)

0108500



CUBIC RELAY/RELAIS CUBIQUE/RELÉ CÚBICO/RELÉ CÚBICO/RELÉ CUBICI/

DOUBLE CONTACT / DOUBLE CONTACTEUR (2T)

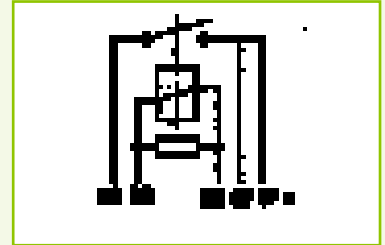
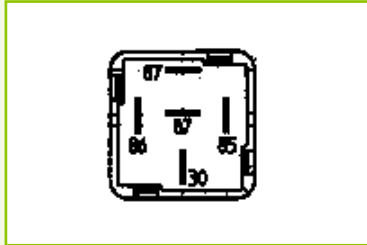

Valeo



U

I

643844

DIN

5

Black / Noir

12 V

40 A

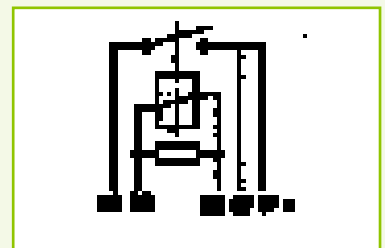

Valeo



U

I

643845

DIN

5

Black / Noir

12 V

30 A

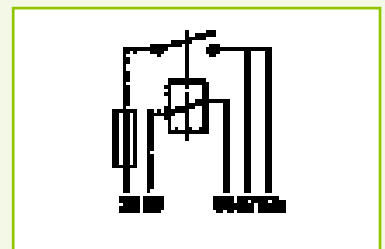

Valeo



U

I

643846

DIN

5

Black / Noir

12 V

30 A



KUBUSVORMIG-RELAIS/WÜRFEL RELAIS/PRZEKAŹNIK/KÜBIK RÖLE/Реле

(.../...)

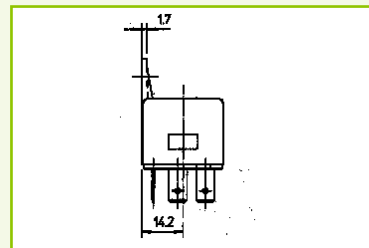
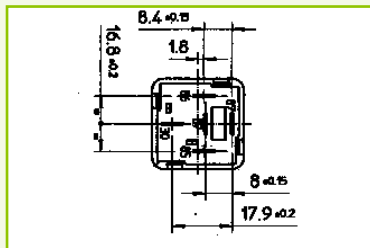
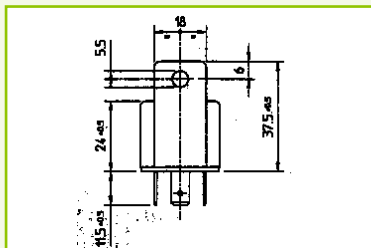

FIX.

CT



(+)

0125980

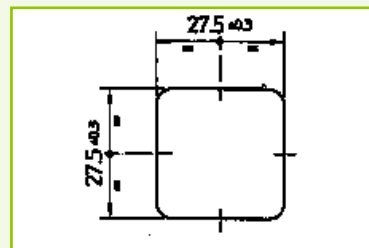
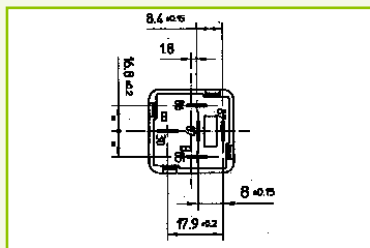
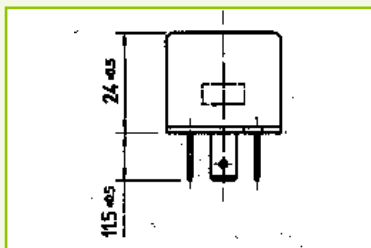

FIX.

CT



(-)

0152020

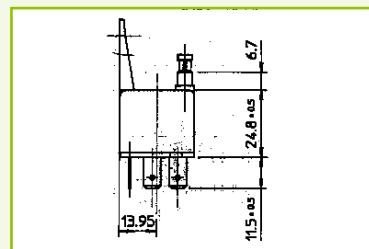
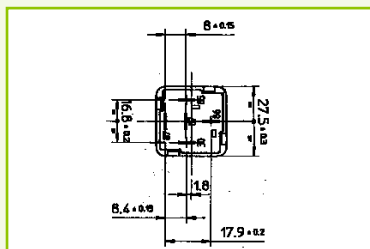
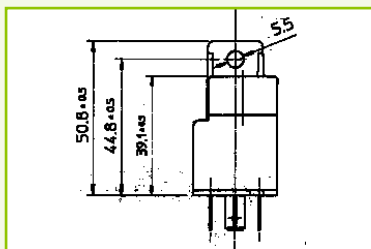

FIX.

CT



(+)

0160970



CUBIC RELAY/RELAIS CUBIQUE/RELÉ CÚBICO/RELÉ CÚBICO/RELÉ CUBICI/

DOUBLE CONTACT / DOUBLE CONTACTEUR (2X1T)

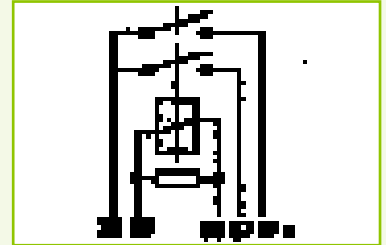
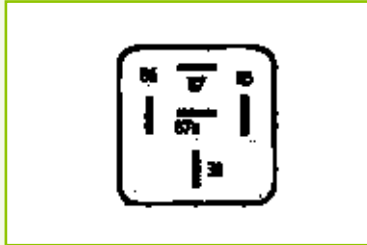

Valeo



U

I

643847

DIN

5

Brown / Marron

12 V

2x15 A

REVERSER / INVERSEUR (RT)

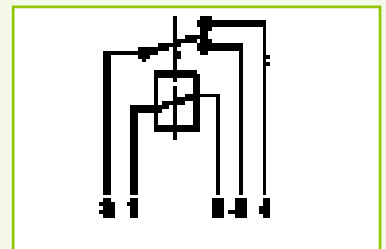
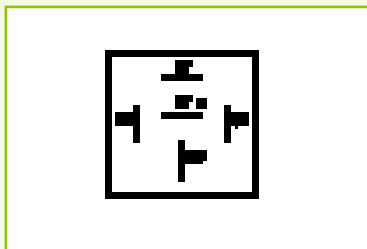

Valeo



U

I

643501

DIN

5

Black / Noir

12 V

10/25 A

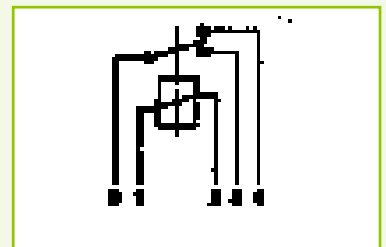
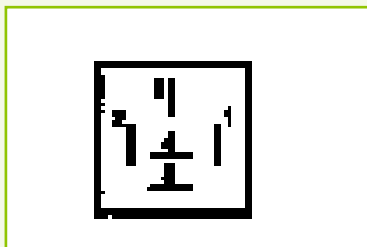

Valeo



U

I

643508

SAE

5

Black / Noir

12 V

10/25 A



KUBUSVORMIG-RELAIS/WÜRFEL RELAIS/PRZEKAŹNIK/KÜBIK RÖLE/Реле

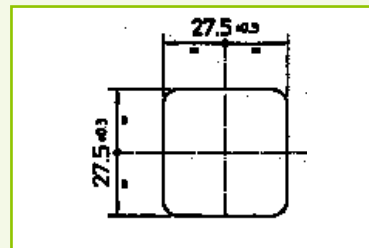
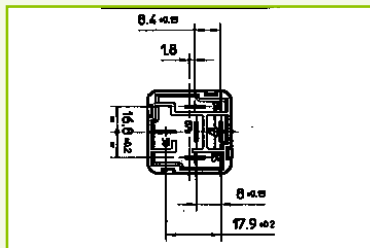
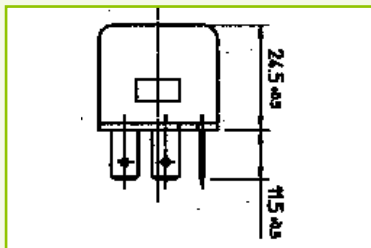

FIX.

CT



(-)

0106300

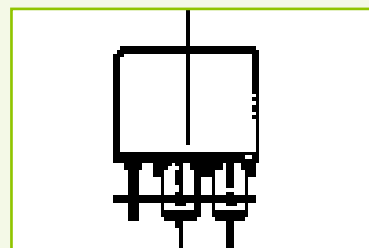
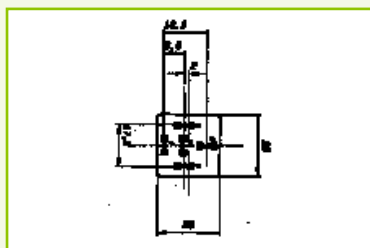
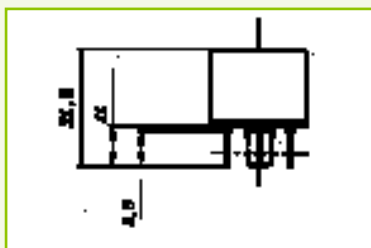

FIX.

CT



(-)

(-)

03501

PSA / RENAULT/...

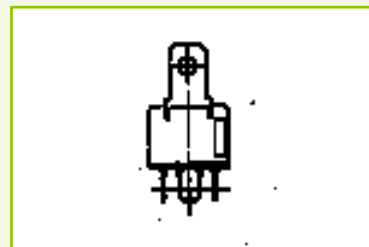
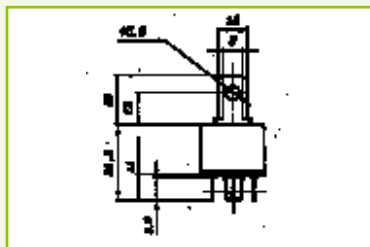
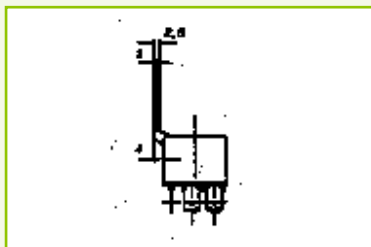

FIX.

CT



(-)

(+)

03508

PSA / RENAULT/...



CUBIC RELAY/RELAIS CUBIQUE/RELÉ CÚBICO/RELÉ CÚBICO/RELÉ CUBICI/

REVERSER / INVERSEUR (RT) (.../...)

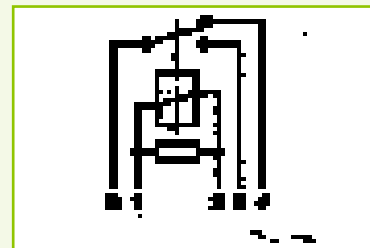
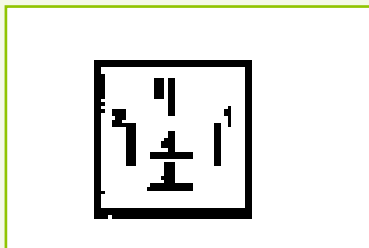

Valeo



U

I

643510

SAE

5

Purple / Violet

12 V

10/25 A

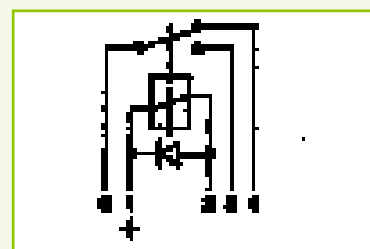
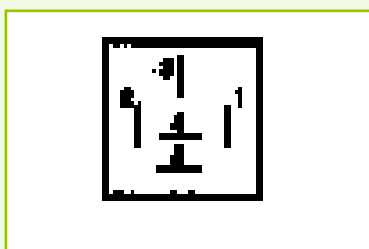

Valeo



U

I

643512

SAE

5

Grey / Gris

12 V

10/25 A

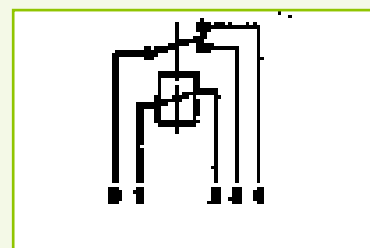

Valeo



U

I

643518

SAE

5

Black / Noir

12 V

10/25 A



KUBUSVORMIG-RELAIS/WÜRFEL RELAIS/PRZEKAŹNIK/KÜBIK RÖLE/Реле

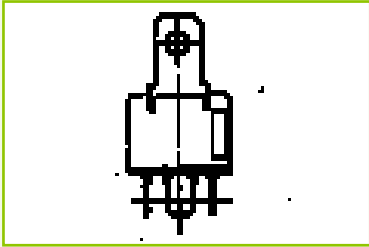
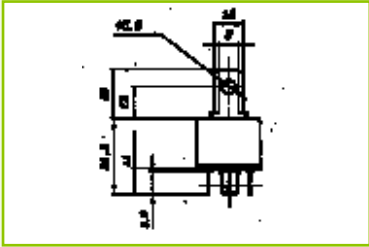
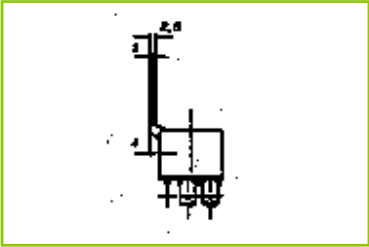

FIX.

CT



(+)

03510

PSA/...

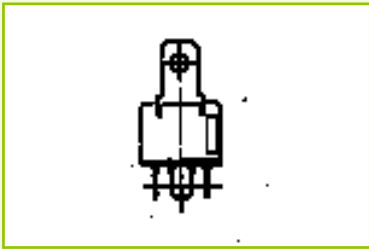
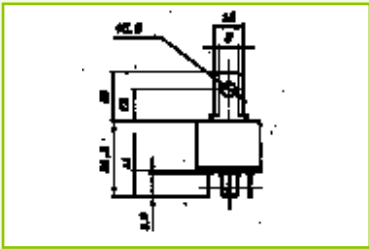
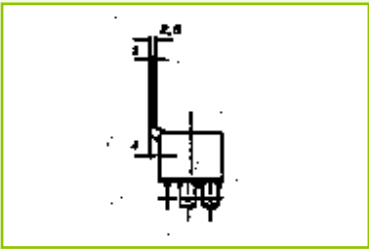

FIX.

CT



(+)

03512

PSA / RENAULT/...

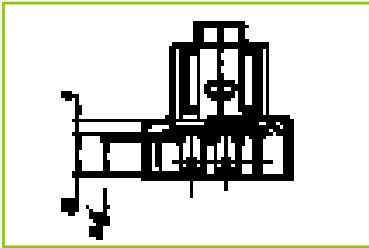
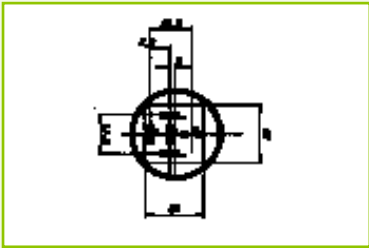
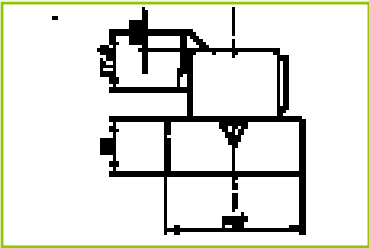

FIX.

CT



(-)

(-)

03518

PSA/...



CUBIC RELAY/RELAIS CUBIQUE/RELÉ CÚBICO/RELÉ CÚBICO/RELÉ CUBICI/

REVERSER / INVERSEUR (RT) (.../...)

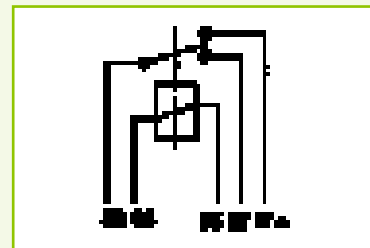
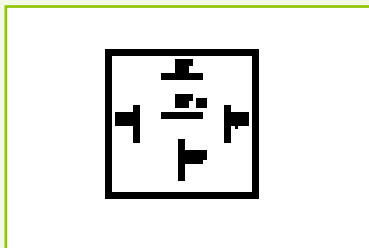

Valeo



U

I

643523

DIN

5

Blue / Bleu

24 V

5/20 A

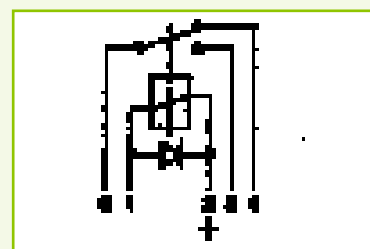
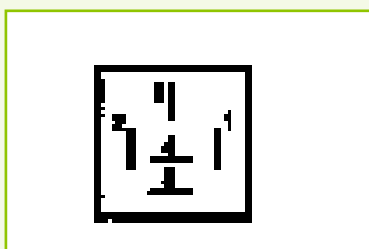

Valeo



U

I

643813

SAE

5

Purple / Violet

24 V

5/20 A

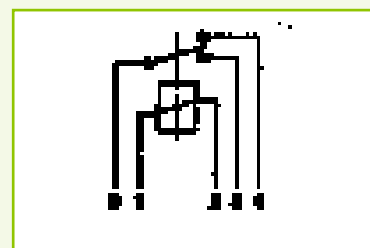
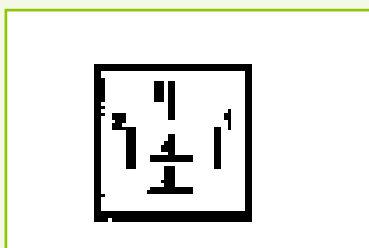

Valeo



U

I

643815

SAE

5

Grey / Gris

12 V

15/40 A



KUBUSVORMIG-RELAIS/WÜRFEL RELAIS/PRZEKAŹNIK/KÜBIK RÖLE/Реле

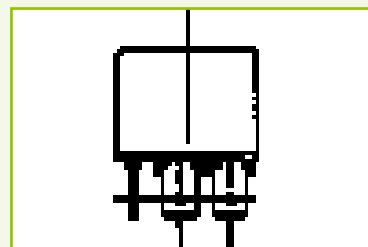
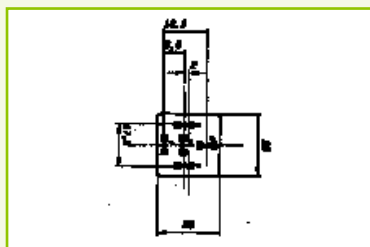
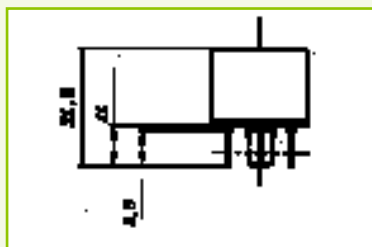

FIX.

CT



(-)

(-)

03523

RENAULT TRUCKS/...

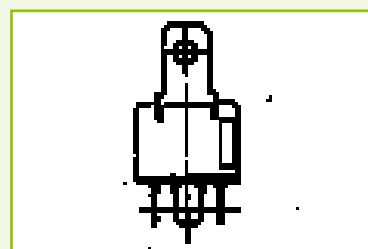
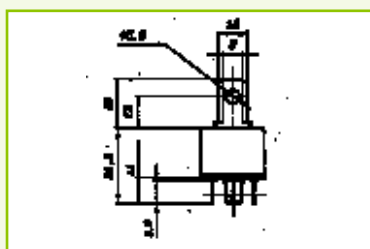
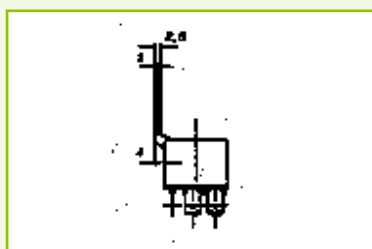

FIX.

CT



(+)

03576

RENAULT TRUCKS/...

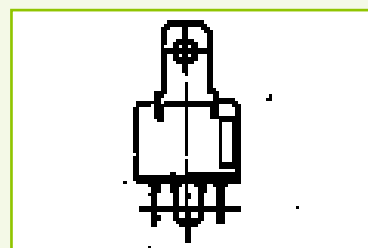
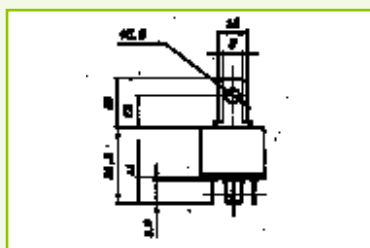
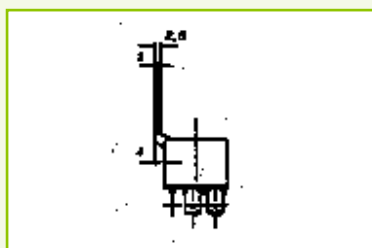

FIX.

CT



(-)

(+)

03535



CUBIC RELAY/RELAIS CUBIQUE/RELÉ CÚBICO/RELÉ CÚBICO/RELÉ CUBICI/

REVERSER / INVERSEUR (RT) (.../...)

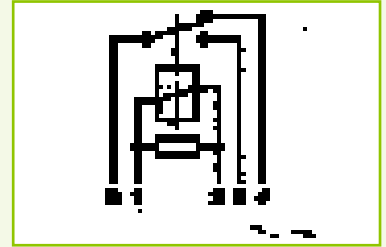
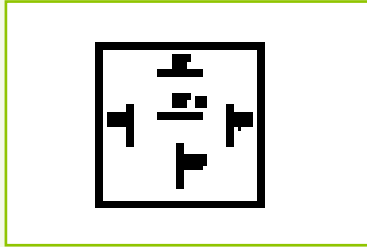

Valeo



U

I

643818

DIN

5

Purple / Violet

12 V

10/25 A

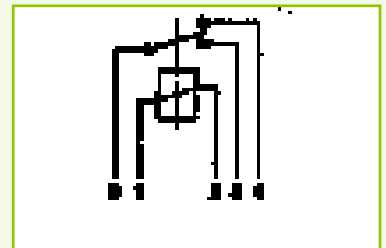
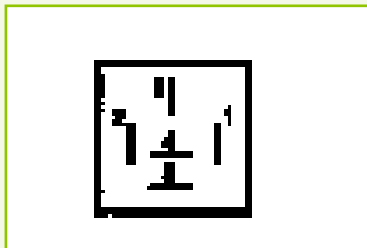

Valeo



U

I

643822

SAE

5

Blue / Bleu

24 V

5/20 A

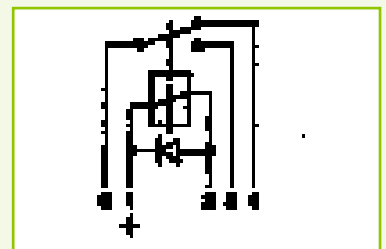
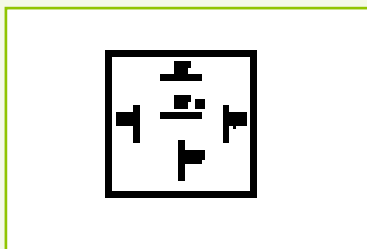

Valeo



U

I

643849

DIN

5

Brown / Marron

12 V

10/25 A



CUBIC RELAY/RELAIS CUBIQUE/RELÉ CÚBICO/RELÉ CÚBICO/RELÉ CUBICI/

REVERSER / INVERSEUR (RT) (.../...)

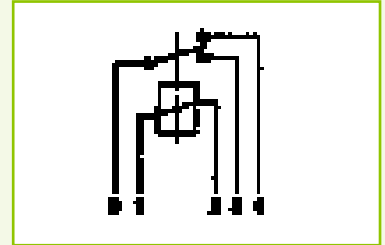
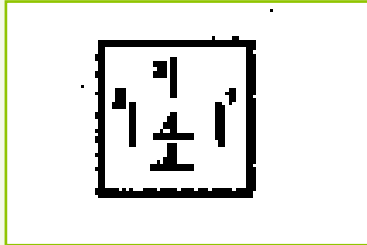

Valeo



U

I

643850

SAE

5

Grey / Gris

12 V

15/40 A

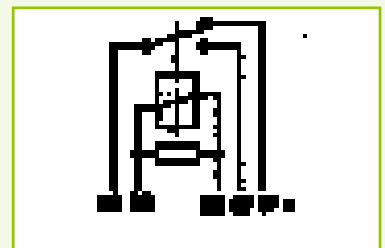
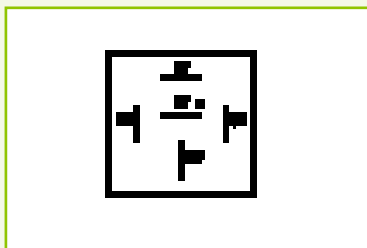

Valeo



U

I

643851

DIN

5

Black / Noir

12 V

15/30 A

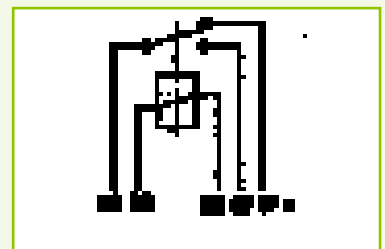
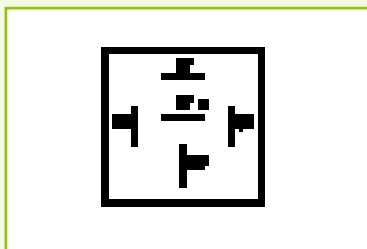

Valeo



U

I

643852

DIN

5

Black / Noir

12 V

15/30 A



KUBUSVORMIG-RELAIS/WÜRFEL RELAIS/PRZEKAŹNIK/KÜBIK RÖLE/Реле

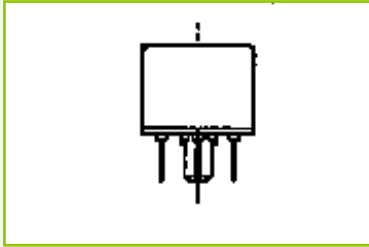
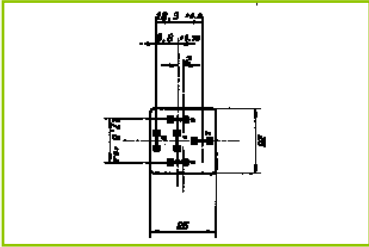
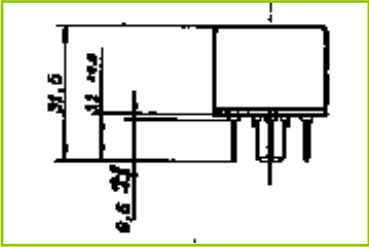

FIX.

CT



(-)

(-)

03534

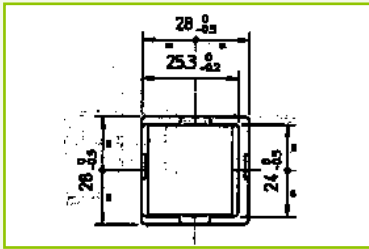
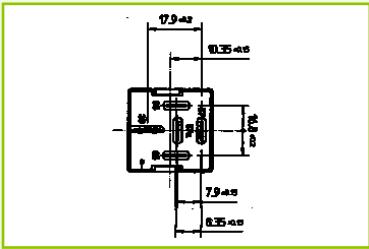
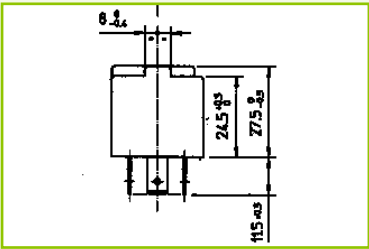

FIX.

CT



(-)

0106400

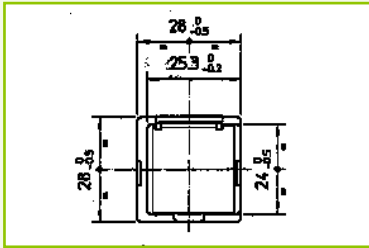
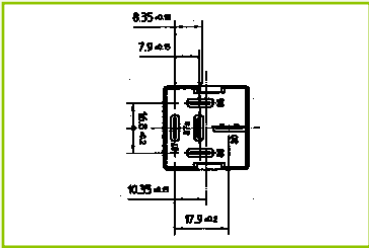
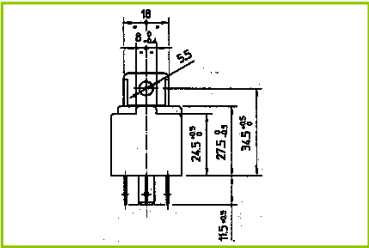

FIX.

CT



(-)

(+)

0110100

AUDI/BMW/FIAT/LANCIA/VW



CUBIC RELAY/RELAIS CUBIQUE/RELÉ CÚBICO/RELÉ CÚBICO/RELÉ CUBICI/

REVERSER / INVERSEUR (RT) (.../...)

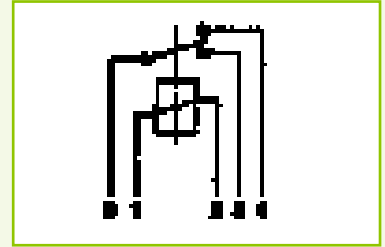
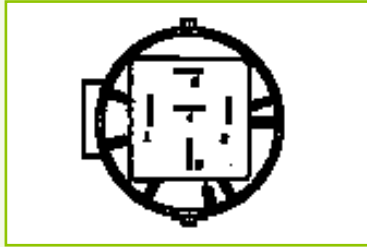

Valeo



U

I

643853

SAE

5

Black / Noir

12 V

10/25 A

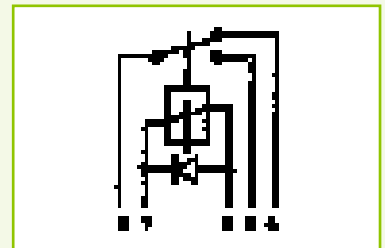
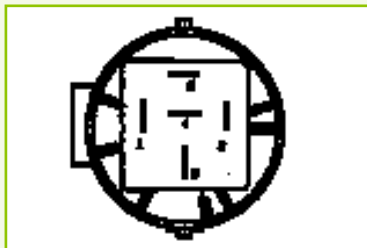

Valeo



U

I

643854

SAE

5

Black / Noir

12 V

10/25 A



POWER RELAY/RELAIS DE PUISSANCE/RELÉ DE POTENCIA/
BEKRACHTIGINGSRELAY/LEISTUNGSRELAIS/PRZEKAŹNIK MOCY/

CONTACT / CONTACTEUR (T)

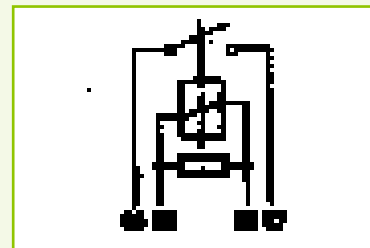
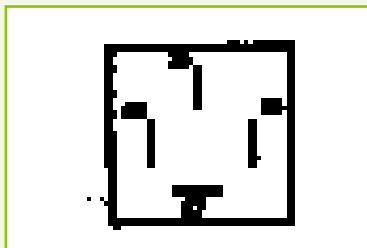

Valeo



U

I

643819

DIN

4

Grey / Gris

12 V

40 A

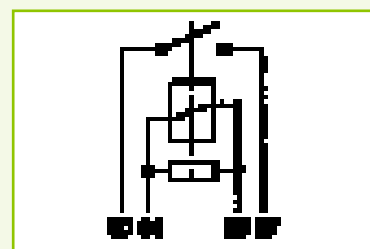
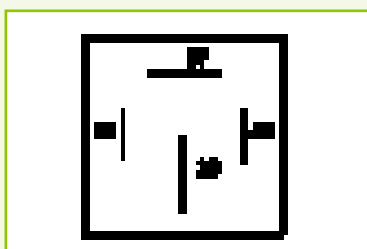

Valeo



U

I

643827

DIN

4

Grey / Gris

12 V

70 A

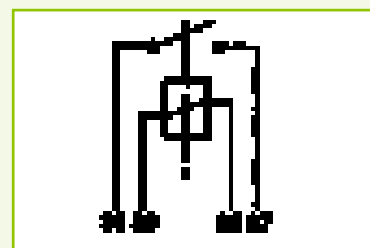
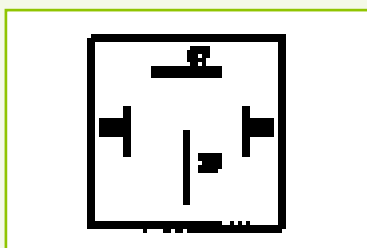

Valeo



U

I

643828

DIN

4

Black / Noir

24 V

30 A



**RELÉ DE POTÊNCIA/RELÉ DI POTENZA/
YÜKSEK GÜÇ RÖLELERİ/Высокоэффективные реле**

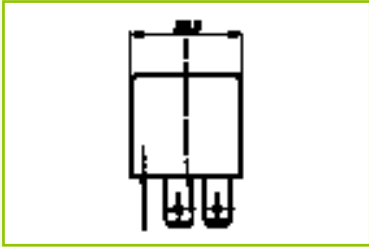
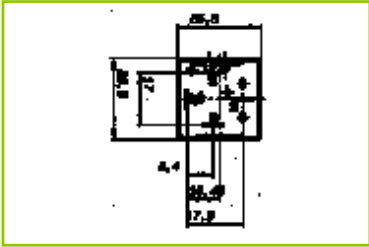
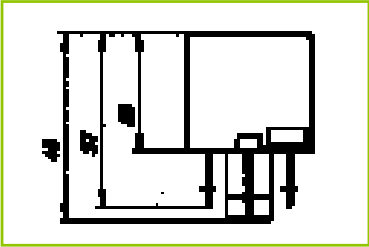

FIX.

CT



(-)

22200030

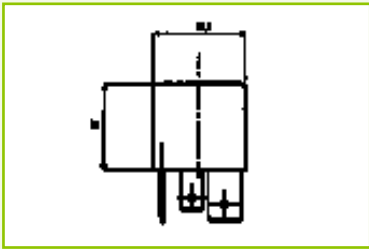
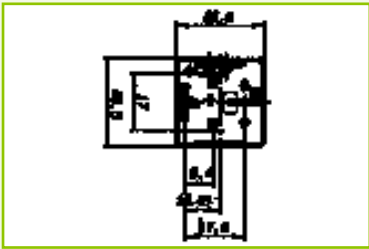
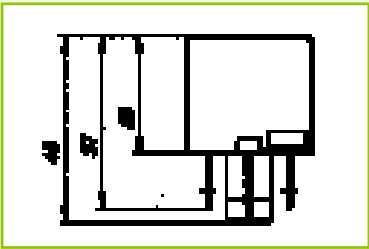

FIX.

CT



(-)

22204013

RENAULT/...

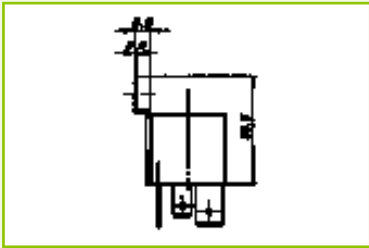
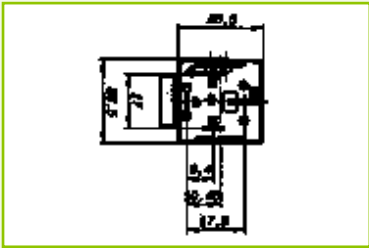
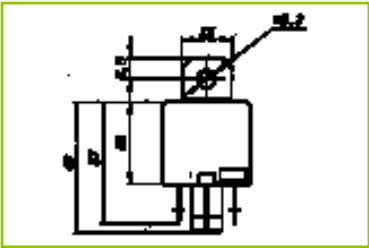

FIX.

CT



(-)

(+/-)

22400111



POWER RELAY/RELAIS DE PUISSANCE/RELÉ DE POTENCIA/ BEKRACHTIGINGSRELAY/LEISTUNGSRELAIS/PRZEKAŹNIK MOCY/

CONTACT / CONTACTEUR (T) (.../...)

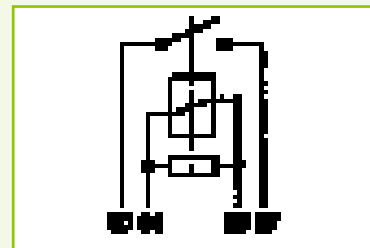
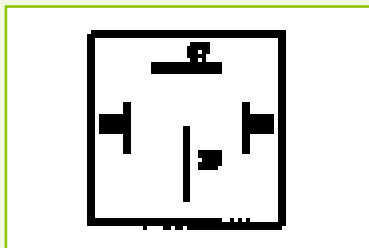

Valeo



U

I

643855

DIN

4

Red / Rouge

12 V

70 A

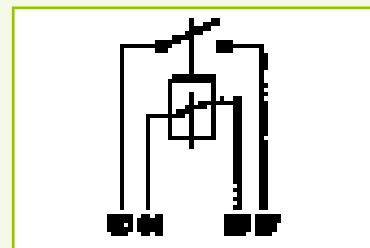
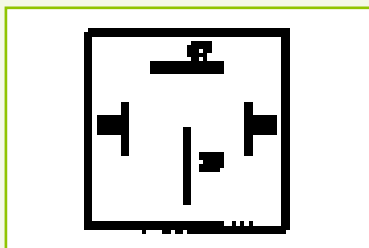

Valeo



U

I

643856

DIN

4

Black / Noir

12 V

70 A



**RELÉ DE POTÊNCIA/RELÉ DI POTENZA/
YÜKSEK GÜÇ RÖLELERİ/Высокоэффективные реле**

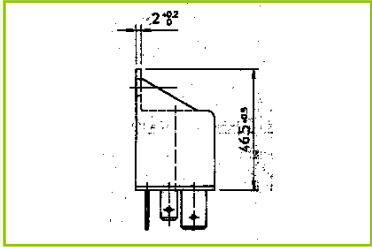
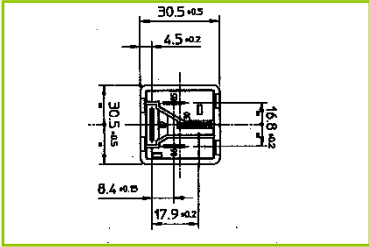
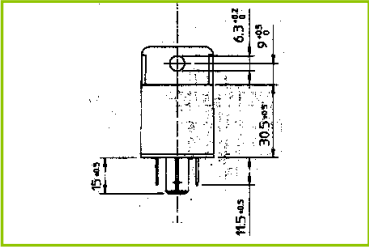

FIX.

CT



(+)

0138400

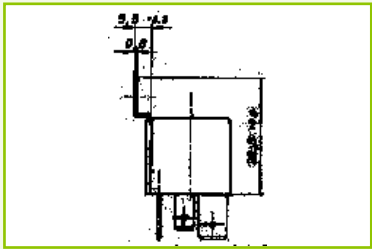
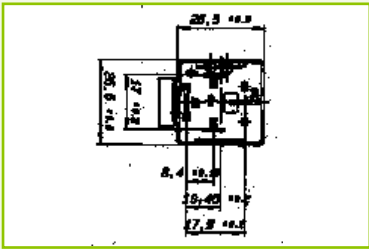
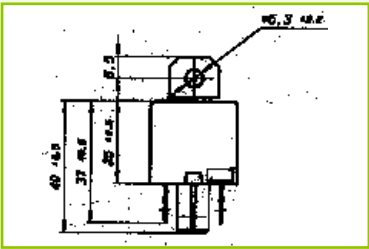

FIX.

CT



(-)

(+/-)

22200111



FOR MICRO-RELAY / POUR MICRO-RELAIS



Valeo				+/...
649300	3	NO	4,8mm	
	2	NO	6,3mm	

FOR CUBIC RELAY / POUR RELAIS CUBIQUE



Valeo				+/...
649100	5	NO	6,3mm	
	4	NO	2,8mm	



Valeo				+/...
649200	5	YES	6,3mm	



Valeo				+/...
649600	5	YES	6,3mm	



FOR POWER RELAY / POUR RELAIS DE PUISSANCE

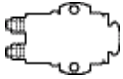

Valeo				+/...
649400	4	NO	2,8mm	
	3	NO	6,3mm	
	2	NO	9,5mm	



**Coil relay contact/Contacteur à relais à bobine (d'appel isolée)/Contactor con relé y bobina/
Ligação com relé e bobina/Contattore a relé con bobina/Relais met spoel/
Cewka/Röle bobin bağlantısı/Катушка**

		Functioning / Fonctionnement	Conjunction voltage / Tension de conjonction	Consumption under tension (cold) / Consommation bobine sous U à froid	Nominal voltage / Tension nominale
053330	CE14	300 A / 30 secondes	4 V	11 A	6 V
053457	CE14	500 A / 10 secondes	8V	6 A	12 V
053458	CE14		16 V	3 A	24 V
071059	CE19	80 / 100 A permanent/permanent	8V	3 A	12 V
071060	CE19		16 V	1,2 A	24 V
074267	CE20	80 / 100 A permanent/permanent	16 V	1,2 A	24 V
093965	CE111	300 A / 30 secondes	8V	6 A	12 V
093966	CE111	500 A / 10 secondes	16 V	3 A	24 V
093966	CE111	80 A :10s closed/fermé /30 s opened/ouvert			
096480	CE112	300 A / 30 secondes	8V	6 A	12 V
094802	CE112	500 A / 10 secondes	16 V	3 A	24 V
094802	CE112	80/100 A :10s closed/fermé /30 s opened/ouvert			
099845	CE113	300 A / 30 secondes	-	-	12 V
098932	CE113	500 A / 10 secondes	-	-	24 V
103456	CE121	-	-	-	24 V
094030	EC41	-	-	-	12 V
094031	EC41	-	-	-	24 V

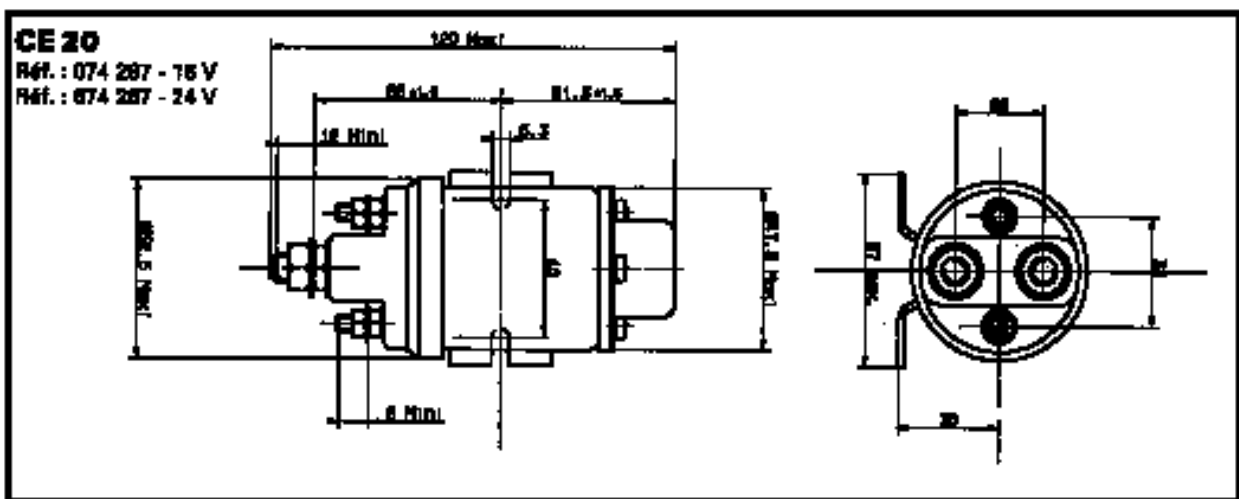
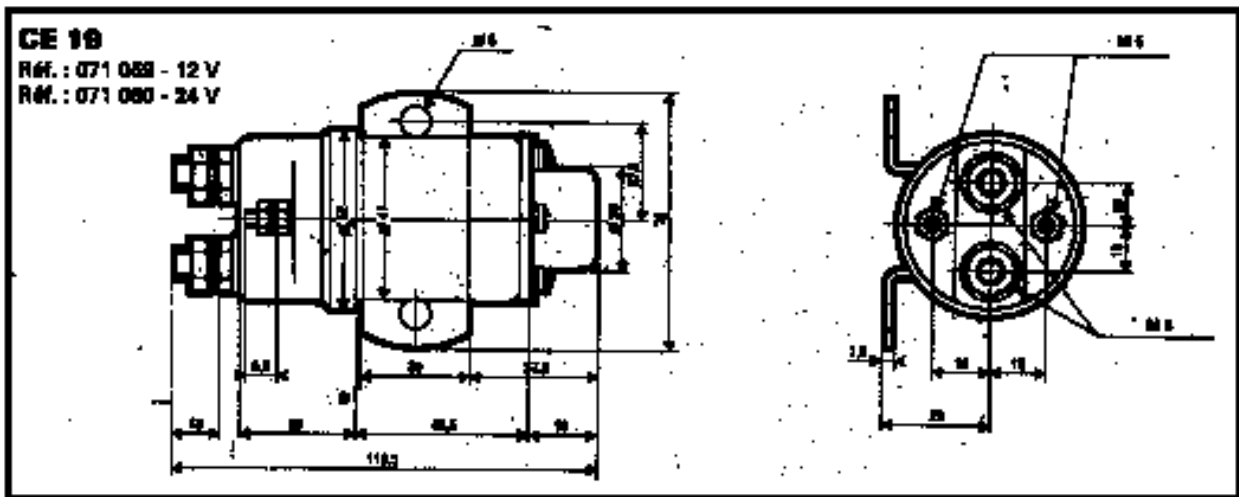
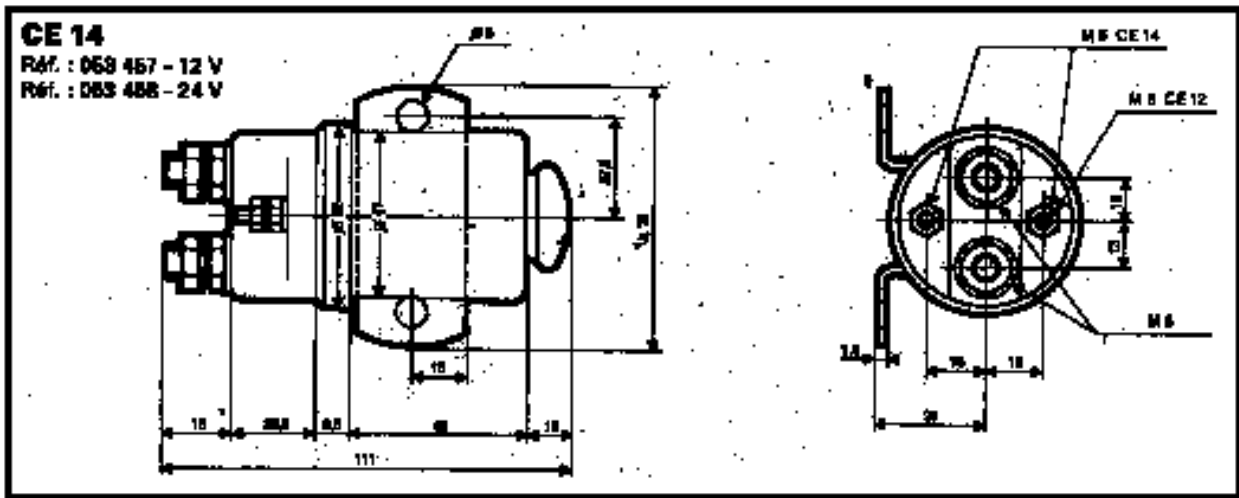
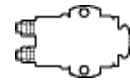

3

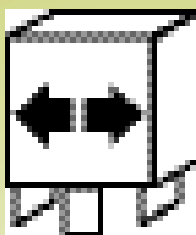

Flasher units
Centrales clignotantes
Centrales de intermitencia
Centrais de intermitentes
Lampeggiatore
Knipperlicht Relais
Blinkerrelais
Przerywacze
Flaşör Üniteleri
Проблесковые приборы

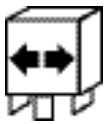

FIX.



DIN/SAE

CT

**Black /
Noir**

Flasher unit
Centrale clignotante
Central de intermitencia
Central de intermitente
Lampeggiatore
Knipperlicht relais
Blinkerrelais
Przerywacz
Flaşör üniteleri
Проблесковые приборы

Fixing
Fixation
Fijación
Fixação
Fissaggio
Fixation
Fixierung

Mocowanie
Takma

Крепление

Number of plugs
Nombre de fiches
Numero de conectores
Número de ligações
Numero di spine
Aantal kabelschoenen
Anzahl Steckverbinder

Ilość podłączeń
Bacak sayısı

Количество соединений

Standard Terminals
Norme de bornage
Norma de embornado
Terminais padrão
Terminali standard
Norme de bornage
Standard Datenverbindung

Standardowe gniazda
Standart kutup

Стандартный контакт

Technical code
Code technique
Código técnico
Código técnico
Codice tecnico
Technische code
technischer Code

Kod techniczny
Teknik kod

Технический код

Black
Noir
Negro
Preto
Nero

Zwart
Schwarz
Czarny
Siyah
Чёрный

**Green /
Vert**

**Grey /
Gris**



Green
Vert
Verde
Verde
Verde
Verde
Groen
Grün
Zielony
Yeşil
Зелёный

Grey
Gris
Gris
Cinzento
Grigio
Grijs
Grau
Szary
Gri

Серый

Trailer
Remorque
Remolque
Reboques
Rimorchio
Anhangwagens
Anhänger
Przyczepa
Römork
Прицеп

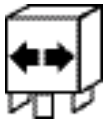

12 V

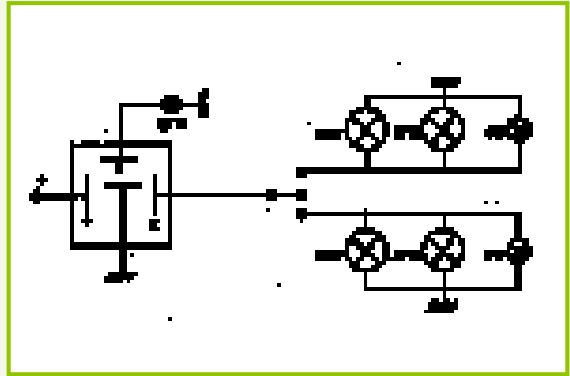
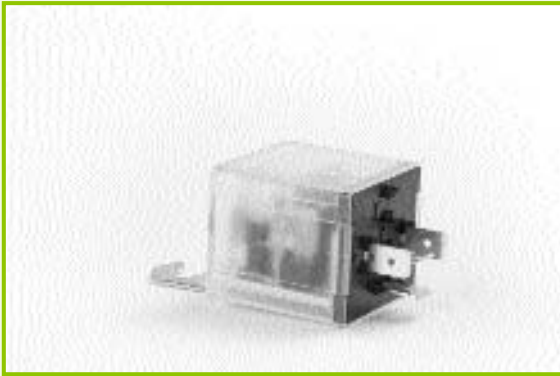

Valeo

CT

U



FIX.



641421

739050

12 V

-

(+)

4

SAE

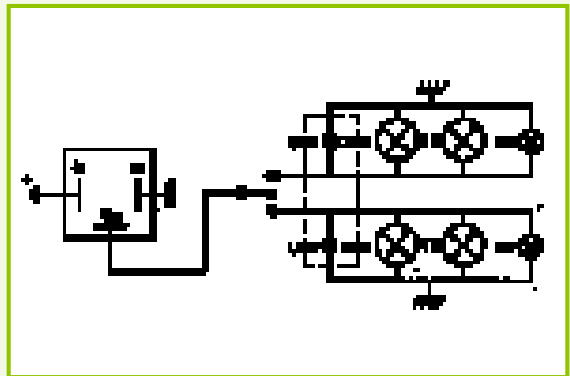
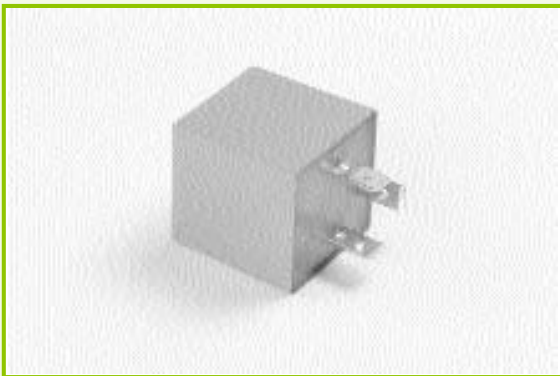

Valeo

CT

U



FIX.



641422

739187

12 V

GREY/GRIS

(-)

3

DIN

CITROËN Berlingo 07/96->12/02 / Evasion /

Saxo / Xantia I 03/93->12/97 / ZX / Jumpy

PEUGEOT 306 / 405 (07/92->) / 605 / 806 / Expert



12 V

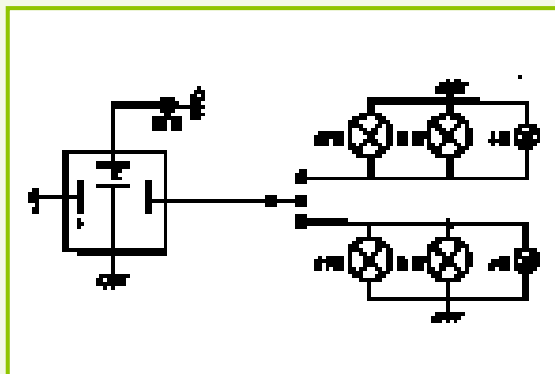

Valeo

CT

U



FIX.



641424

739043

12 V

BLACK / NOIR

(-)

4

SAE PEUGEOT 104 / 204 / 205 / 304 / 305 / 504 / 505 / 604 / J5 / J7 / J9 / CITROËN Dyane / Mehari / Axel / 2CV / LN / Visa / GS / BX / CX / C15 / C25 / C35

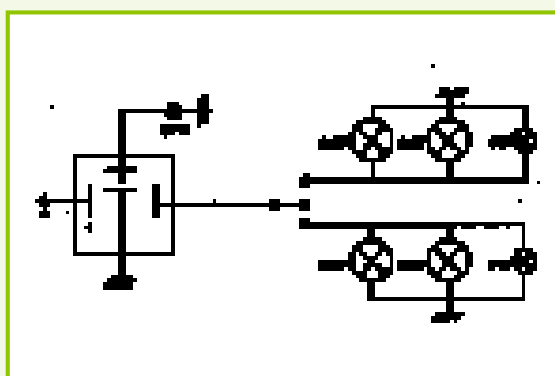

Valeo

CT

U



FIX.



641426

54201045

12 V

BLACK / NOIR

(-)

4

SAE RENAULT Clio 06/90->02/98 / Espace 09/84->06/00 / R19 / R21 / R25 / Express / Trafic 03/89->02 / Master

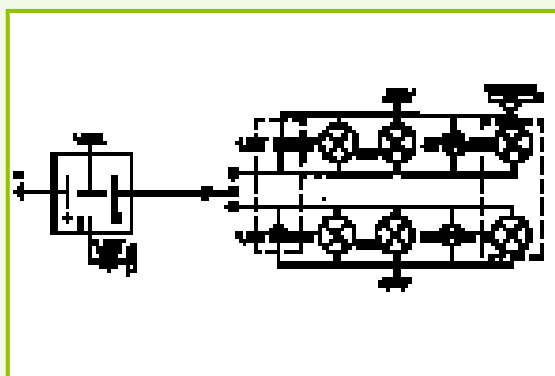

Valeo

CT

U



FIX.



641427

54201044

12 V

BLACK / NOIR

(-)

4

SAE RENAULT Trafic 89-> / Master 81-> Mascott



24 V

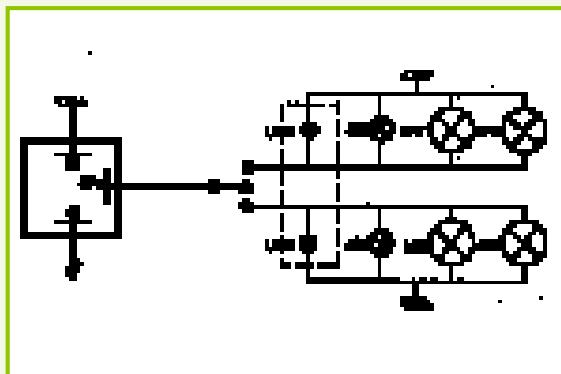
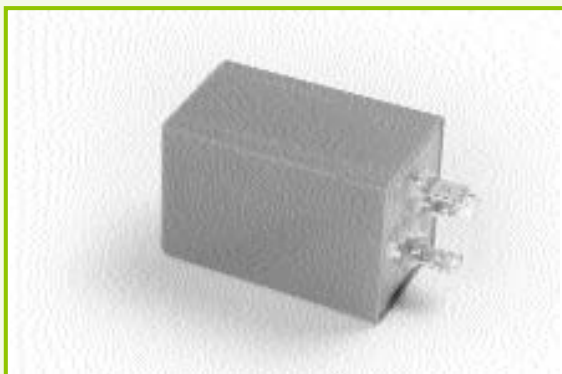

Valeo

CT

U



FIX.



641408

739047

24 V

GREEN/VERT

(-)

3

DIN

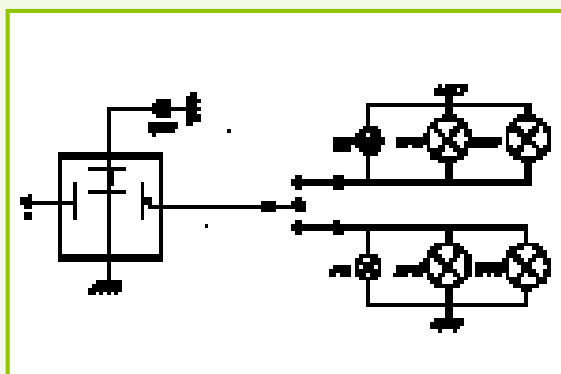

Valeo

CT

U



FIX.



641418

739052

24 V

GREEN/VERT

(+)

4

SAE

RENAULT TRUCKS



Valeo

CT

U



FIX.



641428

739012

24 V

BLACK / NOIR

(+)

14

RENAULT TRUCKS

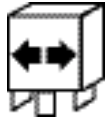

24 V



CT

U



FIX.



641429

739014

24 V

BLACK / NOIR

(+)

9

RENAULT TRUCKS



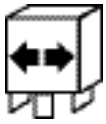

SAE	DIN	
-	31	Earth connection Masse Masa Massa Massa Aardleiding Masse Masa Toprak bağlantısı Macca
+	49	Positive battery Positif batterie Positivo Bateria Positivo da Bateria Polo positivo Pluspool van een batterij Pluspol der Batterie Plus do akumulatora Artı batarya Положительный ток аккумулятора
C	49a	Light Switch Commutateur lampe Conmutador lámpara Comutador de lâmpadas Commutatore lampada Verlichtingsswitch Lampenschalter Przełącznik podświetlany Aydınlatma anahtarı Переключатель подсвечиваемый
R		Vehicle indicator Voyant véhicule Indicador luminoso Indicador luminoso Veicolo viaggiante Controlelampje Kontrolllampe Oznaczenie pojazdu Sinyal lambaları Обозначение автомобиля

4

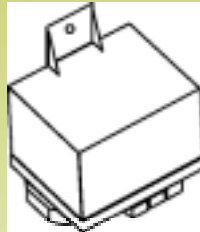

Pre-Heating timers

Temporisateurs de préchauffage

Temporizadores de precalentamiento

Temporizadores de pré-aquecimento

Temporizzatori di preriscaldamento

Voor-gloeirelais









Glühkerzen

Przełączniki czasowe włączania świec żarowych

Ön Isıtma Zamanlayıcıları

Таймер включения свечей накала



		
	100	
  	106	
  	115	



Pre-Heating timer
 Temporisateur de préchauffage
 Temporizador de precalentamiento
 Temporizador de pré-aquecimento
 Temporizzatore di preriscaldamento
 Voor-gloeirelais
 Glühkerze
 Przekaznik czasowy włączania świece żarowych
 Ön ısıtma zamanlayıcısı
 Таймер включения свечей накала



Pre Heat time in seconds 25°C
 Temps de préchauffage en secondes à 25°C
 Tiempo de precalentamiento en segundos a 25° C
 Tempo de pré-aquecimento em segundos a 25°C
 Tempi di preriscaldamento in secondi a 25°C
 Timing in tweede 25°C
 Vorglühzeit bei 25°C in Sekunden
 Czas w sekundach przy 25°C
 25°C sıcaklıkta ön ısıtma süresi (sn.)
 Время в секундах при 25°C



Designation
 Désignation
 Denominación
 Denominação
 Designazione
 Omschrijving
 Identifizierung
 Przeznaczenie
 Tanım
 Предназначение



Pre-Heating
 Préchauffage
 Precalentamiento
 Pré-aquecimento
 Preriscaldamento
 Voor-gloeirelais
 Vorglühen
 Podgrzewanie
 Ön ısıtma
 Нагревание



Pre/post Heating
 Pre-postchauffage
 Pre-pos-calentamiento
 Pré-pós-aquecimento
 Pre/post riscaldamento
 Pre/post verwarming
 Vor- und Nachglühen
 Pre/post grzanie
 Ön/ilave ısıtma
 Pre/post грение

KW/PS

Kilowatt Power / Power Steering
 Puissance en Kilowatt / Puissance fiscale
 Potencia en kilovatios / Potencia fiscal
 Potência em Kilowatts / Potência fiscal
 Potenza in Kilowatt / Cavalli Fiscali
 Kilowatt Power / Stuurbekrachtiging
 Leistung in Kilowatt / Pferdestärke
 Moc w Kw / Wspomaganie kierownicy
 Kilovat olarak güç / Güçlendirilmiş direksiyon
 Мощность в Kw / Усилитель рулевого управления

CT

Technical code
 Code technique
 Código técnico
 Código técnico
 Codice tecnico
 Technische code
 Technischer Code
 Kod techniczny
 Teknik kod
 Технический код

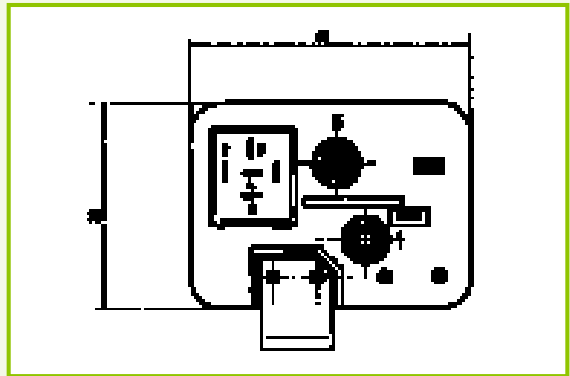

Valeo

CT

U



245600

735054

12 V



15"

PSA

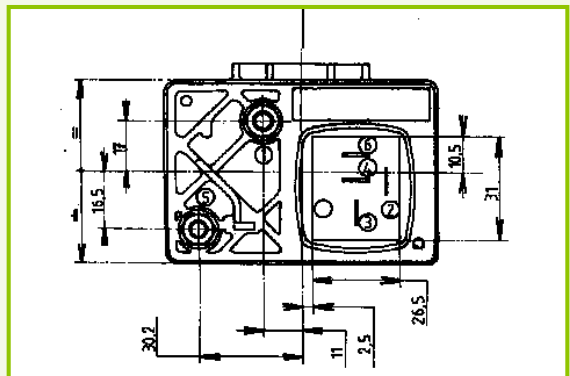

Valeo

CT

U



245603

731034

12 V



7"

PSA

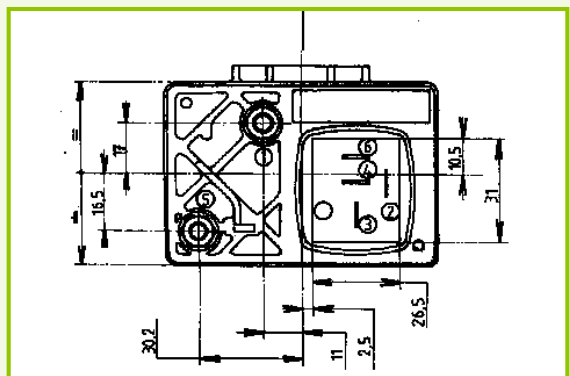

Valeo

CT

U



245604

731048

12 V



7"

RENAULT

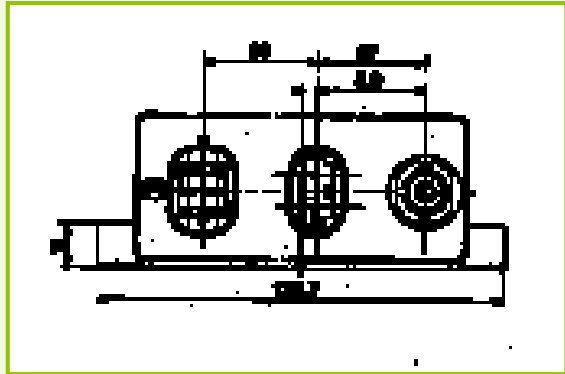

Valeo

CT

U



245607

735045

12 V



7"

RENAULT

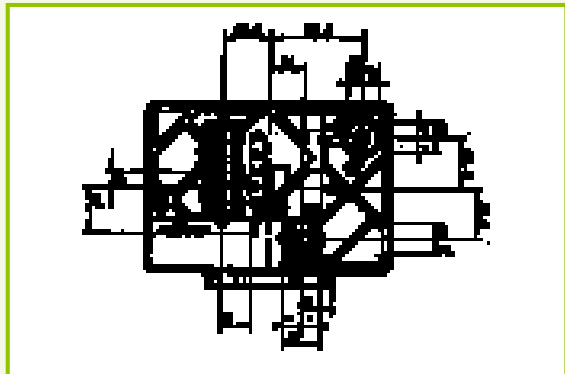

Valeo

CT

U



245609

731049

12 V



7"

PSA

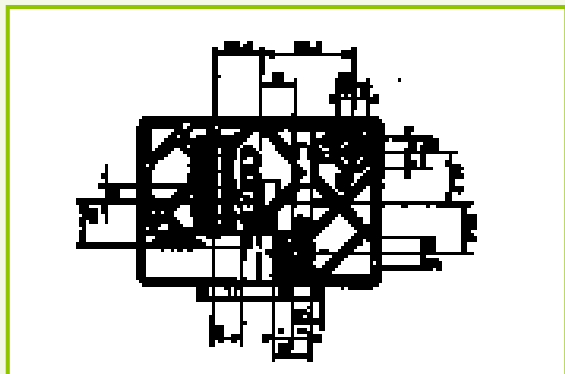

Valeo

CT

U



245612

735063

12 V





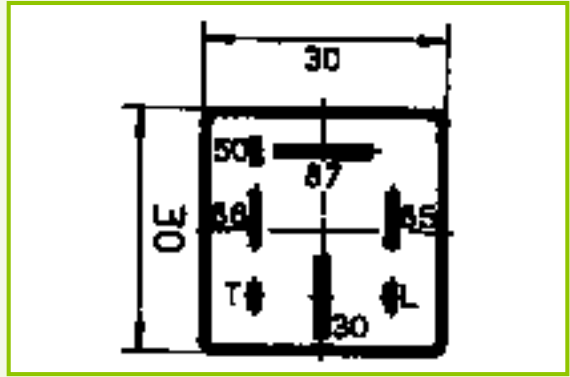
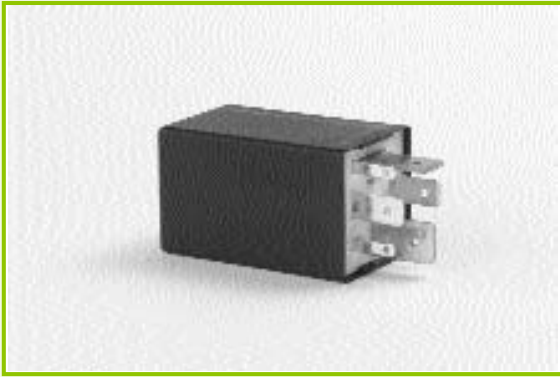

8"

PSA







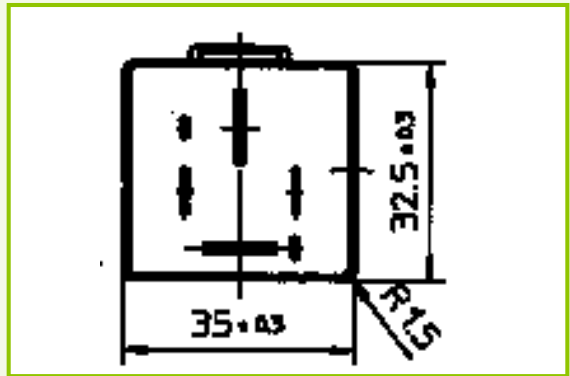
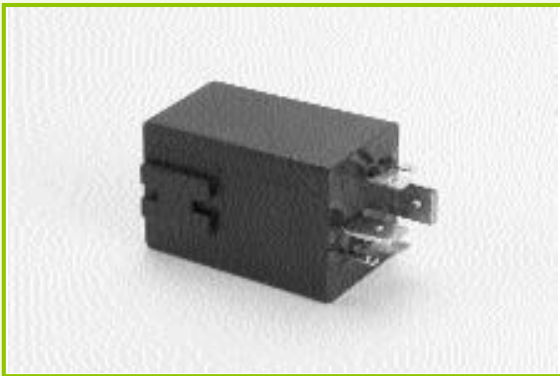

Valeo CT U   

245615 51233001 12 V  VOLKSWAGEN



Valeo CT U   

245616 51216003 12 V  AIXAM, VOLVO

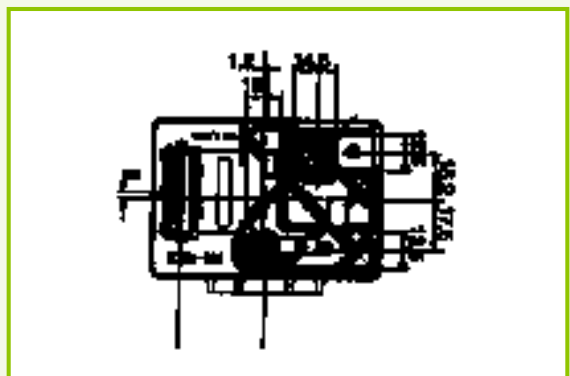
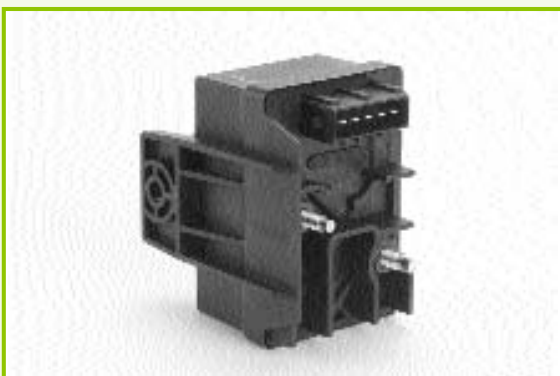

Valeo CT U   

245618 735072 12 V  PSA

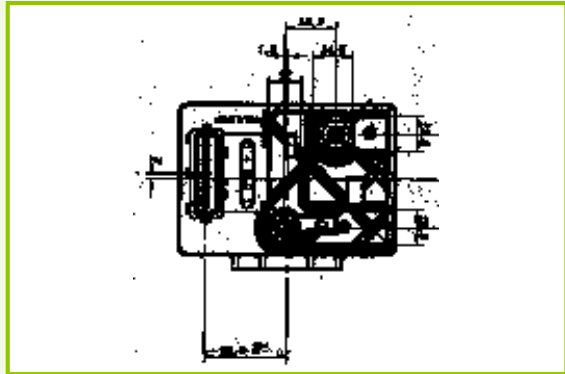
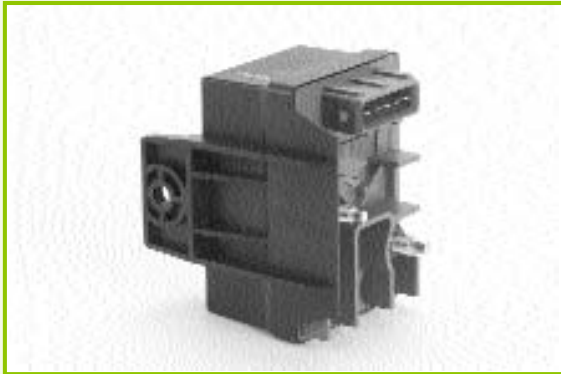

Valeo

CT

U



245621

735076

12 V



PSA

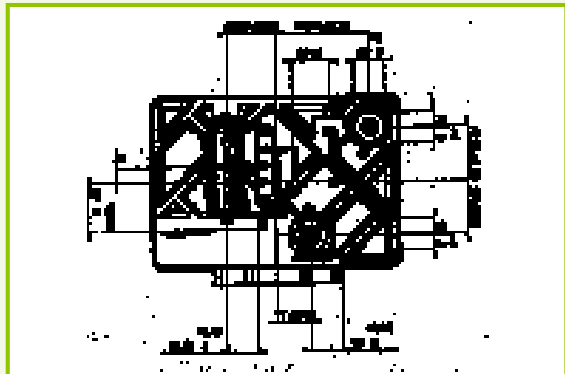
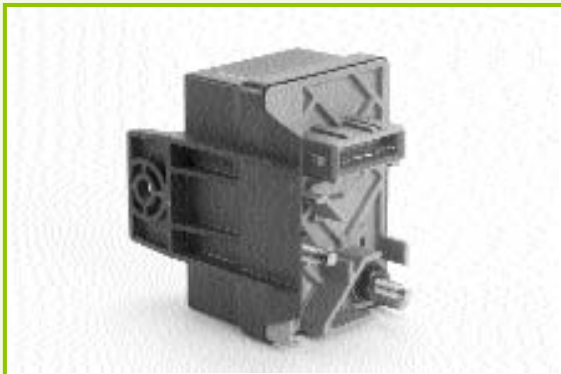

Valeo

CT

U



245622

735068

12 V



PSA

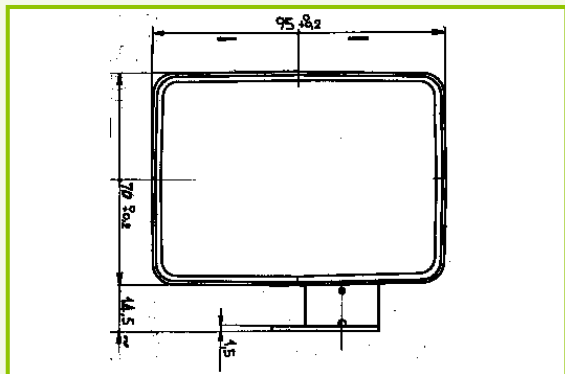

Valeo

CT

U



245623

0247500

12 V



13"

FIAT



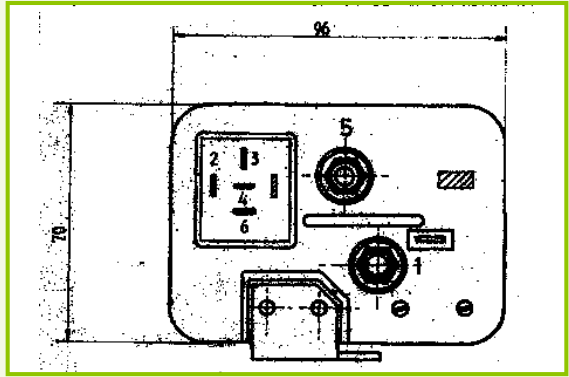

Valeo

CT

U



245624

735052

12 V



7"

RENAULT

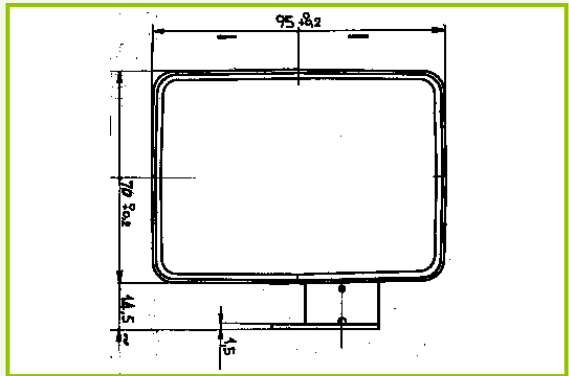

Valeo

CT

U



245625

0247600







12 V



13"

FIAT



	KW/PS			Valeo	CT
AUDI 					
AUDI 80					
1,6 D	40/54	08.80->07.89		245615	5123300102
1,6 TD	51/69	02.82->03.91		245615	5123300102
1,9 D	47/64	08.89->12.91		245615	5123300102
1,9 TD	55/75	09.91->07.95		245615	5123300102
1,9 TDI	66/90	09.91->07.95		245615	5123300102
AUDI 90					
1,6 TD	51/69	10.84->03.90		245615	5123300102
1,6 TD	59/80	04.89->12.91		245615	5123300102
AUDI 100					
2,0 5D	51/69	08.78->07.89		245615	5123300102
2,0 TD 	66/90	11.81->12.87		245615	5123300102
2,0 TD	75/102	03.88->12.90		245615	5123300102
2,4 D	60/82	08.89->12.94		245615	5123300102
2,5 TDI	85/115	06.91->07.94		245615	5123300102
2,5 TDI	88/120	01.90->12.90		245615	5123300102
2,5 TDI 	88/120	04.90->12.91		245615	5123300102
CITROEN 					
AX					
1,4 D, GTD, RD, TD	39/53	09.88->09.94	7"	245603	731034
1,5 D	43/58	10.94->	7"	245603	731034
BX					
1,8 D	44/60	07.85->01.93	7"	245603	731034
1,8 TD, TRD	66/90	03.88->01.93	7"	245603	731034
1,9 D, RD, TD, TRD	47/64	09.83->12.87	7"	245603	731034
1,9 D, TD, TRD	51/69	03.87->	7"	245603	731034
CX					
2,5 D	55/75	08.79->06.82	15"	245600	735054
EVASION					
1,9 TD	68/92	07.94->08.98		245618	73507202
1,9 TD	68/92	09.98->		245618	73507202



	KW/PS		 25 [°]	Valeo	CT
CITROEN  (.../...)					
VISA					
1,8 D	44/60	04.84->03.91	7"	245603	731034
XANTIA					
1,9 D	51/69	03.93->12.97	7"	245609	73104902
1,9 TD	66-68/90-92	03.93->08.98		245618	73507202
2,1 TD	80/109	05.95->08.98		245618	73507202
XANTIA II					
1,9 D (XUD9SD)	55/75	01.98->		245618	73507202
1,9 TD (- XUD9BT)	66-68/90-92	09.98->		245622	51299011
2,0 D (XUD9SD)	80/109	09.98->		245618	73507202
2,1 TD (XUD9BTE)	80/109	09.98->		245618	73507202
XSARA					
D / TD		9.97->		245618	73507202
XM					
2,1 D12	60/82	05.89->06.93	7"	245609	73104902
2,1 D12	80/109	07.93->	8"	245612	73506302
ZX					
1,4 D	39/53	03.91->09.94	7"	245609	73104902
1,5 D	40-42/54-57	02.96->	7"	245609	73104902
1,8 D	44/60	03.91->04.94	7"	245609	73104902
1,8 D	44/60	05.94->	7"	245609	73104902
1,8 D Reflex	44/60	03.91->04.94	7"	245609	73104902
1,8 D Reflex	44/60	05.94->	7"	245609	73104902
1,9 D	49-52/68-71	03.91->04.94	7"	245609	73104902
1,9 D	49-52/68-71	04.94->	7"	245609	73104902
1,9 TD	68/92	09.92->04.94	7"	245609	73104902
1,9 TD	68/92	05.94->	7"	245609	73104902
CITROEN 					
C 15					
1,8 D	44/60	11.84->	7"	245603	731034
C 25					
2,5 D/ TD	54/73	07.81->01.94	15"	245600	735054









	KW/PS			Valeo	CT
CITROEN  (.../...)					
C 32					
2,2 D / TD	45/61	04.79->12.79	15"	245600	735054
C 35					
2,2 D, 2,5 D / TD	45/61	04.79->01.91	15"	245600	735054
JUMPER					
1,9 D	51/69	03.94->05.95	7"	245609	73104902
1,9 D/TD	68/92	03.94->08.98		245618	73507202
JUMPY					
1,9 D/TD	50-52/68-71	11.95->		245618	73507202
FIAT 					
127					
1,3 D	33/45		15"	245600	735054
1,3 D Phase II	33/45		7"	245603	731034
131					
2,0 D Mirafiori	44/60	03.78->01.84	7"	245603	731034
132					
2,0 D	44/60		7"	245603	731034
ARGENTA					
2,5 TD	66/90		7"	245603	731034
CAMPAGNOLA					
2,5 D	53/72	06.79->10.86	7"	245603	731034
CROMA					
2,5 D	55/75	12.85->12.89	7"	245603	731034
REGATA					
1,7 D	43/58	09.83->07.89	7"	245603	731034
1,9 D	48/65	04.84->07.89	7"	245603	731034
1,9 TD	59/80	06.86->07.89	7"	245603	731034



	KW/PS		 25°	Valeo	CT
FIAT  (.../...)					
RITMO					
1,7 D	43/58	10.79->09.82	7"	245603	731034
1,7 D	43/58	10.82->12.87	7"	245603	731034
1,9 TD	59/80	12.85->12.87	7"	245603	731034
UNO					
1,3/1,4/1,7 D,TD all Models	33-52/45-72	06.83->10.96	7"	245603	731034
FIAT 					
242					
2,2 D	44/60		7"	245603	731034
2,5 D (15D)	50/68	09.79->05.85	7"	245603	731034
2,5 D (18D)	50/68	09.79->05.85	7"	245603	731034
DUCATO					
1,9 D Phase I	48/65	03.94->	15"	245600	735054
IVECO 					
DAILY, GRINTA					
2,4 D	53/72	04.78->09.89	7"	245603	731034
DAILY					
2,5 (28 F 8)	53/72	04.78->12.82	7"	245603	731034
2,5 (30 F 8)	53/72	04.78->06.82	7"	245603	731034
2,5 (32 F 8)	53/72	04.78->06.82	7"	245603	731034
2,5 (35 F 8)	53/72	04.78->06.82	7"	245603	731034
2,5 (40 F 8)	53/72	04.78->12.82	7"	245603	731034
LANCIA 					
PRISMA					
1,9 D	48/65	06.84->12.89	7"	245603	731034





	KW/PS		 25°	Valeo	CT
LANCIA  (.../...)					
THEMA					
2,5 TD	74/101	11.84->12.93	7"	245603	731034
2,5 TD	74-85/101-115	11.84->05.92	7"	245603	731034
PEUGEOT 					
106					
1,4 XND, XRD, XTD	37/50	09.91->	7"	245609	73104902
1,5 D	40/54	03.94->	7"	245609	73104902
205					
1,7 D	44/60	10.83->	7"	245603	731034
1,7 TD	58/79	07.85->08.98	7"	245603	731034
1,9 D	48/65	10.87->08.98	7"	245603	731034
305					
1,5 D no 8712358	36/49	02.78->06.81	15"	245600	735054
306					
1,9 XRDT, XTDT (- Van)	52/70	03.93->08.98	7"	245609	73104902
1,9 TD	68/92	03.93->08.98		245618	73507202
309					
1,7 D	44/60	06.86->08.94	7"	245603	731034
1,7 TD	58/79	11.89->12.93	7"	245603	731034
1,9 D	47/64	06.86->12.93	7"	245603	731034
405					
1,7 TD	66/90	03.88->12.92	7"	245603	731034
1,9 D	52/70	07.94->	7"	245603	731034
1,9 TD	68/92	09.93->	7"	245603	731034
406					
1,9 TD(XUD9SD)	55/75	10.95->08.98		245618	73507202
2,1 TD(XUD11BTE)	80/109	10.95->08.98		245622	51299011



	KW/PS		 25°	Valeo	CT
PEUGEOT  (.../...)					
504					
2,1 D(XD2)	43-48/58-65	06.78->04.81	15"	245600	735054
2,1 D(XD2)	43-48/58-65	05.81->09.81	7"	245603	731034
2,3 D(XD90)	47-51/64-70	06.78->04.81	15"	245600	735054
2,3 D(XD90)	47-51/64-70	05.81->06.83	7"	245603	731034
2,3 D(XD88) -> n° 3680624	51/69	7.78->	15"	245600	735054
2,5 D(XD88) n° 3680625 ->	55/75		7"	245603	731034
505					
2,3 D	44-51/60-70	09.79->08.81	15"	245600	735054
2,3 TD	54-59/73-80	09.80->08.81	7"	245603	731034
2,5 D	51-56/69-76	06.81->12.93	15"	245600	735054
2,5 TD	66-70/90-95	10.83->12.93	7"	245603	731034
604					
2,3 TD	54-59/73-80	02.79->09.81	15"	245600	735054
2,3 TD	54-59/73-80	10.81->06.83	7"	245603	731034
2,5 TD	66-70/90-95	07.83->06.86	7"	245603	731034
605					
2,1 SLD	60/82	06.89->	8"	245612	73506302
806					
1,9 TD	68/92	07.94->		245618	73507202
2,1 TD	80/109	05.96->		245618	73507202
PEUGEOT 					
J 5					
1,9 D(XUD9A)	51/69	11.87->01.94	15"	245600	735054
2,5 D(CRD93)	54-55/73-75	09.81->	7"	245603	731034
2,5 TD(CRD93 LS)	70/95	07.87->	15"	245600	735054
J 7					
2,1 D	42/57	07.78->	15"	245600	735054





	KW/PS			Valeo	CT
PEUGEOT  (.../...)					
J 9					
2,1 D	42/57	->06.81	15"	245600	735054
2,3 D	46/62	11.81->	7"	245603	731034
RENAULT 					
CHEROKEE					
2,1 D	59/80	01.85->04.94	7"	245604	731048
CLIO I					
1,9 D	47-48/64-65	05.90->08.98		245607	735045
ESPACE					
2,1 D/TD (J635)	68/92	01.83->		245607	735045
2,1 D / TD (- J635,S635)		01.83->	7"	245604	731048
ESPACE II					
D		03.91->10.96		245607	735045
FUEGO					
2,1 TD	65/88	09.82->07.84	7"	245604	731048
R 5 / SUPER 5					
1,6 D	40/54	09.85->12.96	7"	245604	731048
R 9					
1,6 D	40/54	09.82->09.83	7"	245604	731048
R 11					
1,6 D	40/54	01.83->08.89	7"	245604	731048
R 18					
2,1 D	49/67	08.83->04.88	7"	245604	731048
R 19 / CHAMADE					
1,9 D	48/65	06.88->02.91		245607	735045
1,9 TD, DX -> n° D001068		06.88->02.91		245607	735045
1,9 TD, DX -> n° D000151		06.88->02.91		245607	735045



	KW/PS		 25°	Valeo	CT
RENAULT  (.../...)					
R 20					
2,1 D	47/64	12.83->06.85	7"	245604	731048
2,1 TD	63/86	12.83->06.85	7"	245604	731048
R 21					
1,9 D (F8Q)	48/65	09.89->		245607	735045
2,1 TD (J8S)	65-66/88-90	09.89->		245607	735045
2,1 D (J8S 7.04/7.40/7.84/7.86)	65-66/88-90	09.86->		245607	735045
R 25					
2,1 D (J8S.7.06/7.36)	47-52/64-70	09.83->1992	7"	245604	731048
2,1 D (J8S.7.36)				245607	735045
2,1 TD (J8S.7.08/7.38) -> n° F00500089	63/85		7"	245604	731048
2,1 TD (J8S.7.08/7.38) n° F00500090->	63/85			245607	735045
R 30					
2,1 TD	63/85	12.83->02.84	7"	245604	731048
SAFRANE					
2,1 TD	65/88	->03.97		245607	735045
2,5 TD	85/115	->03.97		245607	735045
RENAULT 					
EXPRESS, EXTRA, RAPID					
1,6 D	40/54	03.86->08.97	7"	245604	731048
1,9 D	40/54	08.91->08.97	7"	245604	731048
MASTER					
2,1 D (J8S)	85/115	10.84->	7"	245604	731048
TRAFIC					
1,9 D	44/60	09.97->03.01	7"	245604	731048
ROVER 					
200 - SERIES					
218 GSD (Peugeot)	49/67	03.91->12.96	7"	245603	731034





	KW/PS			Valeo	CT
ROVER  (.../...)					
400 - SERIES					
418 TD SLD/GSD	65/88	09.91->12.92	7"	245603	731034
SEAT 					
IBIZA					
1,7 D	40/54	06.84->	7"	245603	731034
MALAGA					
1,7 D	40/54	05.85->	7"	245603	731034
RONDA					
1,7 D	40/54	1980->	7"	245603	731034
TALBOT (MATRA, SIMCA) 					
HORIZON					
1,9 D	47/64	07.82->06.86	7"	245603	731034
TAGORA					
2,3 D	59/80	09.81->06.83	7"	245603	731034
VOLKSWAGEN 					
GOLF II					
1,6 D	40/54	08.83->10.91		245615	5123300102
JETTA					
1,6 D	40/54	08.80->02.84		245615	5123300102



Valeo				CT		
245600	CITROEN					
	CX	2,5 D	08.79->06.82	15"	735054	
	CITROEN					
	C 25	2,5 D/ TD	07.81->01.94	15"	735054	
	C 32	2,2 D / TD	04.79->12.79	15"	735054	
	C 35	2,2 D, 2,5 D / TD	04.79->01.91	15"	735054	
	FIAT					
	127	1,3 D		15"	735054	
	FIAT					
	Ducato	1,9 D Phase I	03.94->	15"	735054	
	PEUGEOT					
	305	1,5 D no 8712358	02.78->06.81	15"	735054	
	504	2,1 D(XD2)	06.78->04.81	15"	735054	
	504	2,3 D(XD90)	06.78->04.81	15"	735054	
	504	2,3 D (XD88) -> no 3680624	7.78->	15"	735054	
	505	2,3 D	09.79->08.81	15"	735054	
	505	2,5 D	06.81->12.93	15"	735054	
	604	2,3 TD	02.79->09.81	15"	735054	
	PEUGEOT					
	J 5	1,9 D (XUD9A)	11.87->01.94	15"	735054	
	J 5	2,5 TD (CRD93 LS)	07.87->	15"	735054	
	J 7	2,1 D	07.78->	15"	735054	
	J 9	2,1 D	->06.81	15"	735054	
	245603	CITROEN				
		AX	1,4 D, GTD, RD, TD	09.88->09.94	7"	731034
		AX	1,5 D	10.94->	7"	731034
		BX 17	1,8 D	07.85->01.93	7"	731034
BX 17		1,8 TD, TRD	03.88->01.93	7"	731034	
BX 19		1,9 D, RD, TD, TRD	09.83->12.87	7"	731034	
BX 19		1,9 D, TD, TRD	03.87->	7"	731034	
Visa		1,8 D	04.84->03.91	7"	731034	
CITROEN						
C 15		1,8 D	11.84->	7"	731034	
FIAT						
127		1,3 D Phase II		7"	731034	
131		2,0 D Mirafiori	03.78->01.84	7"	731034	
132		2,0 D		7"	731034	
242		2,2 D		7"	731034	
Argenta		2,5 TD		7"	731034	
Croma		2,5 D	12.85->12.89	7"	731034	
Regata		1,7 D	09.83->07.89	7"	731034	
Regata		1,9 D	04.84->07.89	7"	731034	
Regata		1,9 TD	06.86->07.89	7"	731034	
Ritmo		1,7 D	10.79->09.82	7"	731034	
Ritmo		1,7 D	10.82->12.87	7"	731034	
Ritmo		1,9 TD	12.85->12.87	7"	731034	
Uno		1,3/1,4/1,7 D,TD all Models	06.83->10.96	7"	731034	





Valeo				CT	
245603...	FIAT				
	242	2,5 D (15D)	09.79->05.85	7"	731034
	242	2,5 D (18D)	09.79->05.85	7"	731034
	Campagnola	2,5 D	06.79->10.86	7"	731034
	IVECO				
	Daily	2,5 (28 F 8)	04.78->12.82	7"	731034
	Daily	2,5 (30 F 8)	04.78->06.82	7"	731034
	Daily	2,5 (32 F 8)	04.78->06.82	7"	731034
	Daily	2,5 (35 F 8)	04.78->06.82	7"	731034
	Daily	2,5 (40 F 8)	04.78->12.82	7"	731034
	Daily, Grinta	2,4 D	04.78->09.89	7"	731034
	LANCIA				
	Prisma	1,9 D	06.84->12.89	7"	731034
	Thema	2,5 TD	11.84->12.93	7"	731034
	Thema	2,5 TD	11.84->05.92	7"	731034
	PEUGEOT				
	205	1,7 D	10.83->	7"	731034
	205	1,7 TD	07.85->08.98	7"	731034
	205	1,9 D	10.87->08.98	7"	731034
	309	1,7 D	06.86->08.94	7"	731034
	309	1,7 TD	11.89->12.93	7"	731034
	309	1,9 D	06.86->12.93	7"	731034
	405	1,7 TD	03.88->12.92	7"	731034
	405	1,9 D	07.94->	7"	731034
	405	1,9 TD	09.93->	7"	731034
	504	2,1 D(XD2)	05.81->09.81	7"	731034
	504	2,3 D(XD90)	05.81->06.83	7"	731034
	504	2,5 D (XD88) no 3680625 ->		7"	731034
	505	2,3 TD	09.80->08.81	7"	731034
	505	2,5 TD	10.83->12.93	7"	731034
	604	2,3 TD	10.81->06.83	7"	731034
	604	2,5 TD	07.83->06.86	7"	731034
	PEUGEOT				
	J 5	2,5 D (CRD93)	09.81->	7"	731034
	J 9	2,3 D	11.81->	7"	731034
	ROVER				
	200 - Series	218 GSD (Peugeot)	03.91->12.96	7"	731034
	400 - Series	418 TD SLD/GSD	09.91->12.92	7"	731034
	SEAT				
	Ibiza	1,7 D	06.84->	7"	731034
	Malaga	1,7 D	05.85->	7"	731034
	Ronda	1,7 D	1980->	7"	731034
	TALBOT (MATRA, SIMCA)				
	Horizon	1,9 D	07.82->06.86	7"	731034
	Tagora	2,3 D	09.81->06.83	7"	731034
245604	RENAULT				
	Cherokee	2,1 D	01.85->04.94	7"	731048
	Espace	2,1 D / TD (sauf: J635,S635)	01.83->	7"	731048
	Express, Extra, Rapid	1,6 D	03.86->08.97	7"	731048



Valeo				CT		
245604...	Fuego	2,1 TD	09.82->07.84	7"	731048	
	Master	2,1 D (J8S)	10.84->	7"	731048	
	R 11	1,6 D	01.83->08.89	7"	731048	
	R 18	2,1 D	08.83->04.88	7"	731048	
	R 20	2,1 D	12.83->06.85	7"	731048	
	R 20	2,1 TD	12.83->06.85	7"	731048	
	R 25	2,1 D (J8S.7.06/7.36)	09.83->1992	7"	731048	
	R 25	2,1 TD (J8S.7.08/7.38) -> no F00500089		7"	731048	
	R 30	2,1 TD	12.83->02.84	7"	731048	
	R 5 / Super 5	1,6 D	09.85->12.96	7"	731048	
	R 9	1,6 D	09.82->09.83	7"	731048	
	RENAULT					
	Express, Extra, Rapid	1,9 D	08.91->08.97	7"	731048	
Trafic	1,9 D	09.97->03.01	7"	731048		
245607	RENAULT					
	Clio I	1,9 D	05.90->08.98		735045	
	Espace	2,1 D/TD (J635)	01.83->		735045	
	Espace II	D	03.91->10.96		735045	
	R 19 / Chamade	1,9 D	06.88->02.91		735045	
	R 19 / Chamade	1,9 TD, DX -> no D001068	06.88->02.91		735045	
	R 19 / Chamade	1,9 TD, DX -> no D000151	06.88->02.91		735045	
	R 21	1,9 D (F8Q)	09.89->		735045	
	R 21	2,1 TD (J8S)	09.89->		735045	
	R 21	2,1 D (J8S 7.04/7.40/7.84/7.86)	09.86->		735045	
	R 25	2,1 D (J8S.7.36)			735045	
	R 25	2,1 TD (J8S.7.08/7.38) no F00500090->			735045	
	Safrane	2,1 TD	->03.97		735045	
	Safrane	2,5 TD	->03.97		735045	
	245609	CITROEN				
Xantia		1,9 D	03.93->12.97	7"	73104902	
XM		2,1 D12	05.89->06.93	7"	73104902	
ZX		1,4 D	03.91->09.94	7"	73104902	
ZX		1,5 D	02.96->	7"	73104902	
ZX		1,8 D	03.91->04.94	7"	73104902	
ZX		1,8 D	05.94->	7"	73104902	
ZX		1,8 D Reflex	03.91->04.94	7"	73104902	
ZX		1,8 D Reflex	05.94->	7"	73104902	
ZX		1,9 D	03.91->04.94	7"	73104902	
ZX		1,9 D	04.94->	7"	73104902	
ZX		1,9 TD	09.92->04.94	7"	73104902	
ZX		1,9 TD	05.94->	7"	73104902	
CITROEN						
Jumper		1,9 D	03.94->05.95	7"	73104902	
PEUGEOT						
106		1,4 XND, XRD, XTD	09.91->	7"	73104902	
106		1,5 D	03.94->	7"	73104902	
306		1,9 XRDT, XTDT (sauf: Van)	03.93->08.98	7"	73104902	
245612	CITROEN					
XM	2,1 D12	07.93->	8"	73506302		





Valeo				CT
245612...	PEUGEOT			
	605 2,1 SLD	06.89->	8"	73506302
245615	AUDI			
	Audi 100 2,0 5D	08.78->07.89		5123300102
	Audi 100 2,0 TD	11.81->12.87		5123300102
	Audi 100 2,0 TD	03.88->12.90		5123300102
	Audi 100 2,4 D	08.89->12.94		5123300102
	Audi 100 2,5 TDI	06.91->07.94		5123300102
	Audi 100 2,5 TDI	01.90->12.90		5123300102
	Audi 100 2,5 TDI	04.90->12.91		5123300102
	Audi 80 1,6 D	08.80->07.89		5123300102
	Audi 80 1,6 TD	02.82->03.91		5123300102
	Audi 80 1,9 D	08.89->12.91		5123300102
	Audi 80 1,9 TD	09.91->07.95		5123300102
	Audi 80 1,9 TDI	09.91->07.95		5123300102
	Audi 90 1,6 TD	10.84->03.90		5123300102
	Audi 90 1,6 TD	04.89->12.91		5123300102
	VOLKSWAGEN			
	Golf II 1,6 D	08.83->10.91		5123300102
	Jetta 1,6 D	08.80->02.84		5123300102
245618	CITROEN			
	Evasion 1,9 TD	07.94->08.98		73507202
	Evasion 1,9 TD	09.98->		73507202
	Xantia 1,9 TD	03.93->08.98		73507202
	Xantia 2,1 TD	05.95->08.98		73507202
	Xantia II 1,9 D (XUD9SD)	01.98->		73507202
	Xantia II 2,0 D (XUD9SD)	09.98->		73507202
	Xantia II 2,1 TD (XUD9BTE)	09.98->		73507202
	Xsara D / TD	9.97->		73507202
	CITROEN			
	Jumper 1,9 D/TD	03.94->08.98		73507202
	Jumpy 1,9 D/TD	11.95->		73507202
	PEUGEOT			
	306 1,9 TD	03.93->08.98		73507202
	406 1,9 TD(XUD9SD)	10.95->08.98		73507202
	806 1,9 TD	07.94->		73507202
	806 2,1 TD	05.96->		73507202
245622	CITROEN			
	Xantia II 1,9 TD (sauf: XUD9BT)	09.98->		51299011
	PEUGEOT			
	406 2,1 TD(XUD11BTE)	10.95->08.98		51299011

5

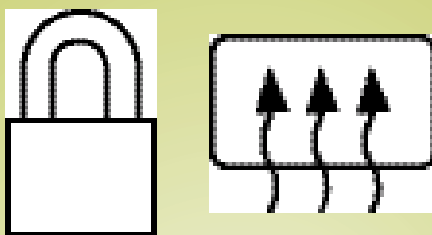

Comfort relays
Temporisateurs de confort
Temporizadores de confort
Temporizadores de conforto
Temporizzatori di confort
Comfort relais
Komfortrelais
Przełączniki
Devre anahtarları
Переключатели





Windshield wiper switch
Cadenceur d'essui vitre
Temporizador limpia parabrisas
Temporizador do limpa pára-brisas
Temporizzatore per tergicristallo ad intermittenza
Ruitenwisser schakelaar
Schalter für Scheibenwaschanlage und Scheibenwischer
Przełącznik wycieraczek
Silecek kumanda kolları
Переключатель стеклоочистителей



Headlamp alarm switch
Buzzer d'oubli éclairage
Avisador de luces encendidas
Avisador de luzes acesas
Interruttore del segnalatore acustico dei proiettori accesi
Verlichtings alarm
Park- und Abblendlichtalarm
Sygnalizator włączonych świateł
Sesli ikazlar
Переключатель сигнализации фарами

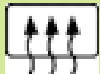

Heated window switch
Temporisateur de dégivrage
Temporizador luneta térmica
Temporizador do aquecimento do vidro
Temporizzatore per lunotto termico
Ruitverwarming
Schalter für heizbare Front- bzw. Heckscheibe
Przełącznik ogrzewania szyby
Cam ısıtma anahtarları
Выключатель нагрева стекол



Door lock switch
Système de verrouillage automatique des portes
Temporizador de cierre automático de puertas
Temporizador do fecho central de portas automático
Temporizzatore per chiusura porte
Sluiten van deuren
Zentralverriegelung
Przełącznik centralnego zamka
Karı kilit anahtarları
Выключатель центрального замка

CT

Technical code
Code technique
Código técnico
Código técnico
Codice tecnico
Technische code
Technischer Code
Kod techniczny
Teknik kod
Технический код



Front
Avant
Delantero
Dianteiro
Anteriore
Voor
Vorne
Przód
Ön
Перёд



WINDSHIELD WIPER SWITCH / CADENCEUR D'ESSUIE-VITRE / TEMPORIZADOR LIMPIA PARABRISAS /
TEMPORIZADOR DO LIMPA PÁRA-BRISAS / TEMPORIZZATORE PER TERGICRISTALLO AD INTERMITTENZA /
RUITENWISSER SCHAKELAAR / SCHALTER FÜR SCHEIBENWASCHANLAGE UND SCHEIBENWISCHER /
PRZELACZNIK WYCIERACZEK / SILECEK KUMANDA KOLLU /
йереключатель стеклоочистителей

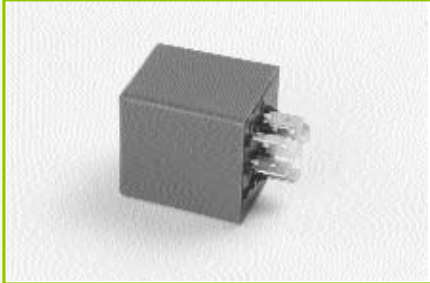

Valeo

U

CT



642406

12V

739229

PSA



Valeo

U

CT



642681

24V

736021

RENAULT TRUCKS



HEADLAMP ALARM SWITCH / BUZZER D'OUBLI D'ÉCLAIRAGE / AVISADOR DE LUCES ENCENDIDAS / AVISADOR DE LUCES ACESAS / INTERRUPTORE DEL SEGNALETORE ACUSTICO DEI PROIETTORI ACCESI / VERLICHTINGS ALARM / PARK- UND ABBLENDLICHTALARM / SYGNALIZATOR WŁACZONYCH ŚWIATEŁ / SESLI İKAZLAR / йереключателъ сигнализации фарами



Valeo

U

CT



479022

12V

736059

CITROËN AX 04/91-> / Evasion / Saxo / Xantia 03/93->12/97 / ZX / Berlingo 07/96->12/02 / Jumpy
PEUGEOT 106 / 205 / 206 / 306 / 309 / 405 / 406 / 605 / 806 / Expert



Valeo

U

CT



642682

12V

57201001

RENAULT Clio / Laguna / R19 / Safrane / Kangoo / Mascott / Master



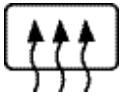

HEATED WINDOW SWITCH / TEMPORISATEUR DE DÉGIVRAGE / TEMPORIZADOR LUNETA TÉRMICA /
TEMPORIZADOR DO AQUECIMENTO DO VIDRO / TEMPORIZZATORE PER LUNOTTO TERMICO / RUITVERWARMING /
SCHALTER FÜR HEIZBARE FRONT- BZW. HECKSCHEIBE / PRZELACZNIK OGRZEWANIA SZYBY /
CAM ISITMA ANAHTARLARI / Выключатель нагрева стекол



Valeo

U

CT



642683

12V

73905912

RENAULT R25 / Mégane I 11/95->08/02 / Spider /
Master 81-> / Mascott

DOOR LOCK SWITCH / SYSTÈME DE VERROUILLAGE AUTOMATIQUE DES PORTES / TEMPORIZADOR DE CIERRE AUTOMÁTICO DE PUERTAS /
TEMPORIZADOR DO FECHO CENTRAL DE PORTAS AUTOMÁTICO / TEMPORIZZATORE PER CHIUSURA PORTE /
SLUITEN VAN DEUREN / ZENTRALVERRIEGELUNG / PRZELACZNIK CENTRALNEGO ZAMKA /
KAPI KILIT ANAHTARLARI / Выключатель центрального замка



Valeo

U

CT



642684

12V

0235810

FIAT Punto / Regata
LANCIA Delta / Ypsilon

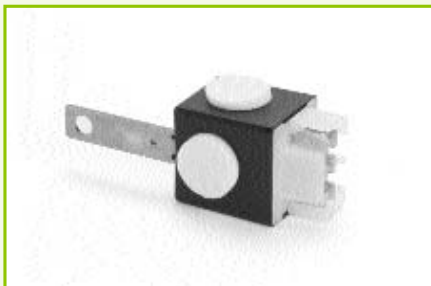

Valeo

U

CT



642685

12V

73602412

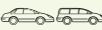
RENAULT Alpine / Clio 06/90->02/98 /
Espace 09/84->10/02 / R19 / R21  /
R25 / Super 5 / Express

6

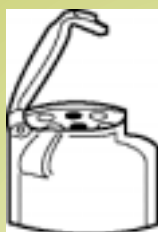

Sockets and plugs
Prises et fiches
Tomas y clavijas
Machos e fêmeas
Prese e schede
Stekkers en stekkendoos
Steckdosen und Stecker
Gniazda i Złącza
Priz ve fişler
Розетки и штепсели





Plug
Fiche
Conector
Ficha
Connettore
stekkerdoos
Steckdosen
Gniazdo
Fişler
штепсели



Socket
Prise
Toma
Tomada
Presa
Stekker
Stecker
Złącze
Priz
Розетки



Adaptor
Adaptateur
Adaptador
Adaptador
Adattatore
Adaptor
Adapter
Adaptor
Adaptör
Адаптор



Number of pins plugs
Nombre de broches fiche
Numero de pines del conector
Número de pinos da ligação (fêmea)
Numero di prese di collegamento
Aantal stekkerdozen
Anzahl Verbindungssteckdosen
Liczba gniazd
Bağlantı priz sayısı
Количество разеток



Number of pins sockets
Nombre de broches prise
Numero de pines del conector
Número de pinos da ligação (macho)
Numero di spinotti di collegamento
Aantal stekker pinnen
Anzahl Verbindungsstifte
Liczba wtyczek
Bağlantı iğne sayısı
Количество штепсели



Type of connector
Type de contact
Tipo de conector
Tipo de ligação
Tipo di contatto
Type stekker
Verbindungstyp
Typ złącza
Bağlantı parçası tipi
Тип контакта



Type of lug
Type de cosse
Tipo de terminal
Tipo de terminal
Tipo di morsetto
Type kabelschoenen
Ösentyp
Typ nóżek
Kutu tipi
Тип соединения



Connection by screw
Connexion par vis
Conexión por tornillo
Ligação por parafuso
Connessione con vite
Schroef verbinding
Verbindung durch Schrauben
Połączenie wkrętem
Vidalı bağlantı
Подключение болтом



Connection by lugs
Connexion par cosses
Conexión con protección
Ligação por anel metálico
Connessione con morsetti
Stekkerverbinding
-

Połączenie nóżkami
Kutulu bağlantı
Подключение соединениями

Ø

Diameter
Diámetro
Diámetro
Diámetro
Diámetro
Diameter
Durchmesser
Średnica
Çap
Диаметр



Battery connectivity
Connectique batterie
Conector de batería
Ligação da bateria
Connessione batteria
Batterij-aansluiting
Batterieanschluss
Podłączenie akumulatora
Batarya bağlantısı
Контакт для аккумулятора

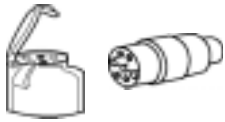

Fuses box /
Boitier porte-
fusibles

Fuses box
Boitier Porte-fusibles
Caja porta fusibles
Caixa porta-fusíveis
Scatola porta fusibili
Zekeringkast
Sicherungskasten
Skrzynka bezpieczników
Sigorta kutusu
Коробка предохранителей



7 PINS / 7 BROCHES - 12 V

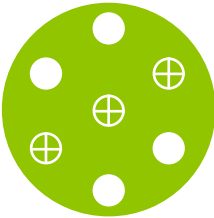
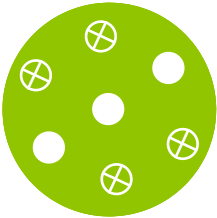
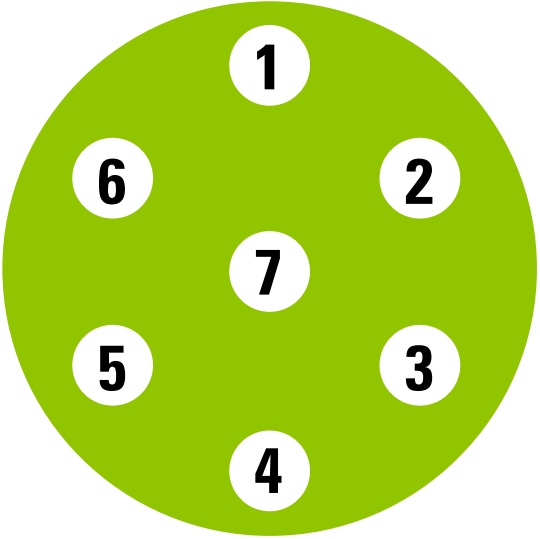
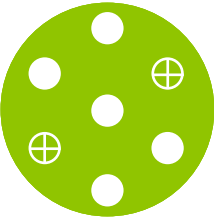
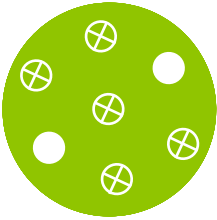

U	ISO/DIN			N°
12 V	ISO 1724 TYPE N			
12 V	ISO 3732 TYPE S			

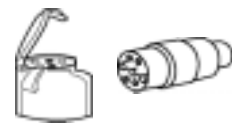

N TYPE / TYPE N (ISO 1724)

	Function / Fonction / Función / Função / Funzione / Functie / Funktion / Funkcja / İşlev / Функция	Ø		
1	Left indicators	1,5	Yellow	Geel
1	Indicateurs de direction gauche	1,5	Jaune	Gelb
1	Indicador de dirección izquierda	1,5	Amarillo	Żółty
1	Pisca Esquerdo	1,5	Amarelo	Sarı
1	Indicatore di direzione sinistro	1,5	Tuorlo	Жёлтый
2	Rear fog light	1,5	Blue	Blauw
2	Feu de brouillard arrière	1,5	Bleu	Blau
2	Antiniebla trasero	1,5	Azul	Niebieski
2	Anti-nevoeiro traseiro	1,5	Azul	Mavi
2	Antinebbia posteriore	1,5	Blu	Голубой
3	Earth connection	2,5	White	Wit
3	Masse	2,5	Blanc	Weiss
3	Masa	2,5	Blanco	Biały
3	Massa	2,5	Branco	Beşaz
3	Massa	2,5	Bianco	Белый
4	Right indicators	1,5	Green	Groen
4	Indicateurs de direction droit	1,5	Vert	Grün
4	Indicador de dirección derecha	1,5	Verde	Zielony
4	Pisca Direito	1,5	Verde	Yeşil
4	Indicatore di direzione destro	1,5	Verde	Зелёный
5	Side lights, side markers, numberplate light right	1,5	Brown	Kastanje
5	Feux de positions, feux d'encombement, éclairage plaque droite	1,5	Marron	Kastanie
5	Luz de posición, luz de emergencia, iluminación matrícula Derecha	1,5	Marrón	Brazowy
5	Luz de presença, luz de emergência, luz de matrícula Direita	1,5	Castanho	Kahverengi
5	Luci di posizione, luci di ingombro, luci targa Destra	1,5	Marrone	Бронзовый
6	Stop lights	1,5	Red	Rood
6	Feux stop	1,5	Rouge	Rot
6	Luz de freno	1,5	Rojo	Czerwony
6	Luz de travão	1,5	Vermelho	Kırmızı
6	Luce stop	1,5	Rosso	Красный
7	Side lights, side markers, numberplate light left	1,5	Black	Zwart
7	Feux de positions, feux d'encombement, éclairage plaque gauche	1,5	Noir	Schwarz
7	Luz de posición, luz de emergencia, iluminación matrícula izquierda	1,5	Negro	Czarny
7	Luz de presença, luz de emergência, luz de matrícula Esquerda	1,5	Preto	Siyah
7	Luci di posizione, luci di ingombro, luci targa sinistra	1,5	Nero	Чёрный

S TYPE / TYPE S (ISO 3732)



	Function / Fonction / Función / Função / Funzione / Functie / Funktion / Funkcja / İşlev / Функция	Ø		
1	Reversing lights	1,5	Yellow	Geel
1	Feux de marche arrière	1,5	Jaune	Gelb
1	Luz de marcha atrás	1,5	Amarillo	Żółty
1	Luz de marcha atrás	1,5	Amarelo	Sarı
1	Luci di retromarcia	1,5	Tuorlo	Жёлтый
2	Signal connection trailer			
2	Signalisation raccordement remorque			
2	Testigo de conexión remolque			
2	Indicador de ligação do atrelado			
2	Indicatore di collegamento rimorchio			
3	Return earth connection for contact 4	2,5	White	Wit
3	Masse de retour pour contact n°4	2,5	Blanc	Weiss
3	Masa de retorno para contacto n° 4	2,5	Blanco	Biały
3	Massa de retorno para contacto 4	2,5	Branco	Beşaz
3	Massa di ritorno per contatto n.4	2,5	Bianco	Белый
4	Positive direct current feed from battery	2,5	Green	Groen
4	Positif d'alimentation directe de batterie	2,5	Vert	Grün
4	Positivo de alimentación directa de la batería	2,5	Verde	Zielony
4	Positivo de alimentação directa da bateria	2,5	Verde	Yeşil
4	Positivo d'alimentazione diretta della batteria	2,5	Verde	Зелёный
5	No allocation	1,5	Brown	Kastanje
5	Aucune application	1,5	Marron	Kastanie
5	Ninguna aplicación1,5	1,5	Marrón	Brazowy
5	Sem aplicação	1,5	Castanho	Kahverengi
5	Nessuna applicazione	1,5	Marrone	Бронзовый
6	Positive ignition key	2,5	Red	Rood
6	Positif d'alimentation sous clefs de mise en route	2,5	Rouge	Rot
6	Positivo de alimentación con llave de puesta en marcha	2,5	Rojo	Czerwony
6	Positivo de alimentação com chave ligada	2,5	Vermelho	Kırmızı
6	Positivo d'alimentazione sotto chiave inserita	2,5	Rosso	Красный
7	Return earth connection for contact 6	2,5	Black	Zwart
7	Masse de retour pour contact n°6	2,5	Noir	Schwarz
7	Masa de retorno para contacto n° 6	2,5	Negro	Czarny
7	Massa de retorno para contacto 6	2,5	Preto	Siyah
7	Massa di ritorno per contatto n.6	2,5	Nero	Чёрный

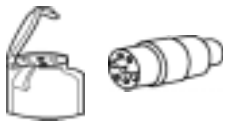



7 PINS / 7 BROCHES - 24 V

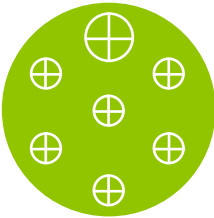
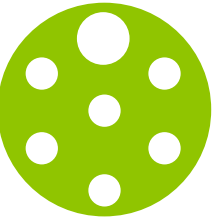
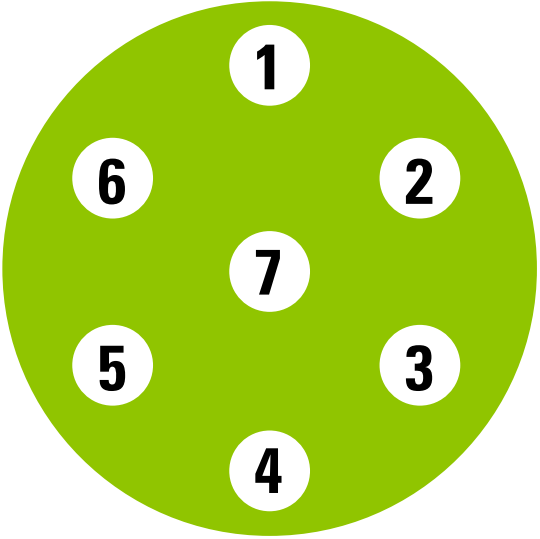
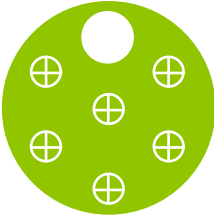
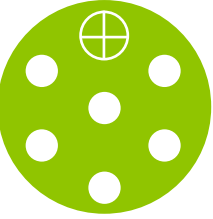

U	ISO/DIN			N°
24 V	ISO 1185 DIN 72579 TYPE N			
24 V	ISO 3731 TYPE S			

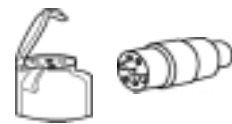

N TYPE / TYPE N (ISO 1185 / DIN 72579)

Function / Fonction / Función / Função / Funzione / Functie / Funktion / Funkcja / İşlev / Функция		Ø			
1	Earth connection	Aardleiding	2,5	White	Wit
1	Masse	Masse	2,5	Blanc	Weiss
1	Masa	Masa	2,5	Blanco	Biały
1	Massa	Toprak bağlantısı	2,5	Branco	Beyaz
1	Massa	Масса	2,5	Bianco	Белый
2	Side lights, side markers, numberplate light left	Zijverlichting, zijmarkering, nummerbordverlichting links	1,5	Black	Zwart
2	Feux de positions, feux d'encombement, éclairage plaque gauche	Schlussleuchte, Umriss-Begrenzungsleuchte, Kennzeichenleuchte Links	1,5	Noir	Schwarz
2	Luz de posición, luz de emergencia, iluminación matrícula izquierda	Obrysówki, światła pozycje, oświetlenie tablicy rejestracyjnej lewej	1,5	Negro	Czarny
2	Luz de presença, luz de emergência, luz de matrícula Esquerda	Yan sinyaller, plaka lambası sağ	1,5	Preto	Siyah
2	Luci di posizione, luci di ingombro, luci targa sinistra	Стояночный свет, фонарь номерного знака Левый	1,5	Nero	Чёрный
3	Left indicators	Linker knipperlicht	1,5	Yellow	Geel
3	Indicateurs de direction gauche	Fahrtrichtungsanzeiger Links	1,5	Jaune	Gelb
3	Indicador de dirección izquierda	Lewy kierunkowskaz	1,5	Amarillo	Zółty
3	Pisca Esquerdo	Sağ göstergesi	1,5	Amarelo	Sarı
3	Indicatore di direzione sinistro	Левый указатель поворота	1,5	Tuorlo	Жёлтый
4	Stop lights	Remlichten	1,5	Red	Rood
4	Feux stop	Bremslichter	1,5	Rouge	Rot
4	Luz de freno	Światła stop	1,5	Rojo	Czerwony
4	Luz de travão	Stop lambası	1,5	Vermelho	Kırmızı
4	Luce stop	Стоп-сигнал	1,5	Rosso	Красный
5	Right indicators	Rechter knipperlicht	1,5	Green	Groen
5	Indicateurs de direction droit	Fahrtrichtungsanzeiger Rechts	1,5	Vert	Grün
5	Indicador de dirección derecha	Prawy kierunkowskaz	1,5	Verde	Zielony
5	Pisca Direito	Sol göstergesi	1,5	Verde	Yeşil
5	Indicatore di direzione destro	Правый указатель поворота	1,5	Verde	Зелёный
6	Side lights, side markers, numberplate light right	Zijverlichting, zijmarkering, nummerbordverlichting Rechts	1,5	Brown	Kastanje
6	Feux de positions, feux d'encombement, éclairage plaque droite	Schlussleuchte, Umriss-Begrenzungsleuchte, Kennzeichenleuchte Rechts	1,5	Marron	Kastanie
6	Luz de posición, luz de emergencia, iluminación matrícula Derecha	Obrysówki, światła pozycje, oświetlenie tablicy rejestracyjnej prawej	1,5	Marrón	Brazowy
6	Luz de presença, luz de emergência, luz de matrícula Direita	Yan sinyaller, plaka lambası sol	1,5	Castanho	Kahverengi
6	Luci di posizione, luci di ingombro, luci targa Destra	Стояночный свет, фонарь номерного знака Правый	1,5	Marrone	Бронзовый
7	Control for the trailer braking system	Bediening voor de remverlichten van aanhangwagen	1,5	Blue	Blauw
7	Contrôle freinage remorque	Kontrolle Bremsvorgang Anhänger	1,5	Bleu	Blau
7	Control freno remolque	Kontrola systemu hamulcowego przyczepy	1,5	Azul	Niebieski
7	Controlo de travão de atrelado	Römork fren sistemi kontrolü	1,5	Azul	Mavi
7	Controllo del sistema di frenata del rimorchio	Контроль тормозной системы прицепа	1,5	Blu	Голубой

S TYPE / TYPE S (ISO 3731)



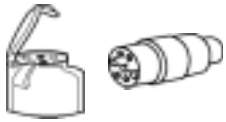

Function / Fonction / Función / Função / Funzione / Functie / Funktion / Funkcja / İşlev / Функция		Ø			
1	Earth connection	Aardleiding	1,5	White	Wit
1	Masse	Masse	1,5	Blanc	Weiss
1	Masa	Masa	1,5	Blanco	Biały
1	Massa	Toprak bağlantısı	1,5	Branco	Beyaz
1	Massa	Масса	1,5	Bianco	Белый
2	No allocation	Geen allocatie	1,5	Black	Zwart
2	Aucune application	Kein Anschluss	1,5	Noir	Schwarz
2	Ninguna aplicación	Wolny	1,5	Negro	Czarny
2	Sem aplicação	İlintisiz	1,5	Preto	Siyah
2	Nessuna applicazione	Свободный	1,5	Nero	Чёрный
3	Reversing lights	Achteruitrij-verlichting	1,5	Yellow	Geel
3	Feux de marche arrière	Rückfahrleuchte	1,5	Jaune	Gelb
3	Luz de marcha atrás	Światła cofania	1,5	Amarillo	Zółty
3	Luz de marcha atrás	Geri vites lambası	1,5	Amarelo	Sarı
3	Luci di retromarcia	Свет заднево хода	1,5	Tuorlo	Жёлтый
4	Positive direct current feed from battery	Directe positive voeding van de batterij	2,5	Red	Rood
4	Positif d'alimentation directe de batterie	Pos.Stromspeisung direkt von Batterie	2,5	Rouge	Rot
4	Positivo de alimentación directa de la batería	Plus bezpośredni z akumulatora	2,5	Rojo	Czerwony
4	Positivo de alimentação directa da bateria	Artı bağlantıyı aküden yapınız	2,5	Vermelho	Kırmızı
4	Positivo d'alimentazione diretta della batteria	Положительный ток с аккумулятора	2,5	Rosso	Красный
5	Sensor with earth return	Sensor met aarde retour	1,5	Green	Groen
5	Capteur avec retour à la masse	Sensor mit Rückkehrmasse	1,5	Vert	Grün
5	Captador con retorno a la masa	Czujnik z masą powrotną	1,5	Verde	Zielony
5	Sensor com retorno de massa	Toprak dönüşlü algılayıcı	1,5	Verde	Yeşil
5	Sensore con collegamento alla massa	Датчик с массой возврата	1,5	Verde	Зелёный
6	Positive ignition key	Positive contactsleutel	2,5	Brown	Kastanje
6	Positif d'alimentation sous clefs de mise en route	Pos.Stromspeisung mit Zündschlüssel	2,5	Marron	Kastanie
6	Positivo de alimentación con llave de puesta en marcha	Plus stacyjki	2,5	Marrón	Brazowy
6	Positivo de alimentação com chave ligada	Artı ateşleme anahtarı	2,5	Castanho	Kahverengi
6	Positivo d'alimentazione sotto chiave inserita	Положительный ток замка зажигания	2,5	Marrone	Бронзовый
7	Rear fog light	Achter mistlamp	2,5	Blue	Blauw
7	Feu de brouillard arrière	Nebelschlussleuchte	2,5	Bleu	Blau
7	Antiniebla trasero	Tyłne światło przeciwmgielne	2,5	Azul	Niebieski
7	Anti-nevoeiro traseiro	Arka sis lambası	2,5	Azul	Mavi
7	Antinebbia posteriore	Задний противотуманный свет	2,5	Blu	Голубой





13 PINS / 13 BROCHES - 12 V

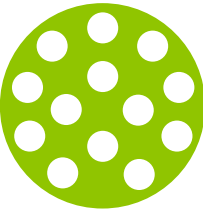

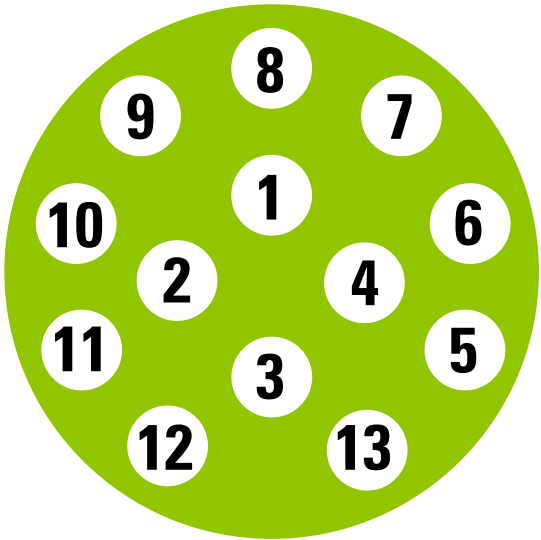
U	ISO/DIN			N°
12 V	ISO 11446 DIN 72570			

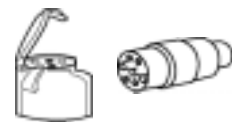
ISO 11446 / DIN 72570

Function / Fonction / Función / Função / Funzione / Functie / Funktion / Funkcja / İşlev / Функция	Ø	
1 Left indicators	1,5	Yellow
1 Indicateurs de direction gauche	1,5	Jaune
1 Indicador de dirección izquierda	1,5	Amarillo
1 Pisca Esquerdo	1,5	Amarelo
1 Indicatore di direzione sinistro	1,5	Tuorlo
1 Linker knipperlicht	1,5	Geel
1 Fahrtrichtungsanzeiger Links	1,5	Gelb
1 Lewy kierunkowskaz	1,5	Zółty
1 Sağ göstergesi	1,5	Sarı
1 Левый указатель поворота	1,5	Жёлтый
2 Rear fog light	1,5	Blue
2 Feu de brouillard arrière	1,5	Bleu
2 Antiniebla trasero	1,5	Azul
2 Anti-nevoeiro traseiro	1,5	Azul
2 Antinebbia posteriore	1,5	Blu
2 Achter mistlamp	1,5	Blauw
2 Nebelschlussleuchte	1,5	Blau
2 Tylne światło przeciwmgielne	1,5	Niebieski
2 Arka sis lambası	1,5	Mavi
2 Задний противотуманный свет	1,5	Голубой
3 Earth for contacts 1 to 8	2,5	White
3 Masse pour contact du n°1 au n°8	2,5	Blanc
3 Masa para contacto del n° 1 al n° 8	2,5	Blanco
3 Massa para contacto do n.º 1 ao n.º 8	2,5	Branco
3 Massa di contatto da n.1 a n. 8	2,5	Bianco
3 Massa voor contact 1 tot en met 8	2,5	Weiss
3 Masse für Kontakte 1 bis 8	2,5	Weiss
3 Masa dla złącz 1 do 8	2,5	Biały
3 I'den 8'e kadar olan bağlantılar için toprak	2,5	Beyaz
3 Масса для контактов 1 до 8	2,5	Белый
4 Right indicators	1,5	Green
4 Indicateurs de direction droit	1,5	Vert
4 Indicador de dirección derecha	1,5	Verde
4 Pisca Direito	1,5	Verde
4 Indicatore di direzione destro	1,5	Verde
4 Rechter knipperlicht	1,5	Groen
4 Fahrtrichtungsanzeiger Rechts	1,5	Grün
4 Prawy kierunkowskaz	1,5	Zielony
4 Sol göstergesi	1,5	Yeşil
4 Правый указатель поворота	1,5	Зелёный
5 Side lights, side markers, numberplate light right	1,5	Brown
5 Feux de positions, feux d'encombrement, éclairage plaque droite	1,5	Marron
5 Luz de posición, luz de emergencia, iluminación matrícula Derecha	1,5	Marrón
5 Luz de presença, luz de emergência, luz de matrícula Direita	1,5	Castanho
5 Luci di posizione, luci di ingombro, luci targa Destra	1,5	Marrone
5 Zijverlichting, zijmarkering, nummerbordverlichting Rechts	1,5	Kastanje
5 Schlussleuchte, Umriss-Begrenzungsleuchte, Kennzeichenleuchte Rechts	1,5	Kastanie
5 Obrysówki, światła pozycje, oświetlenie tablicy rejestracyjnej prawej	1,5	Brazowy
5 Yan sinyaller, plaka lambası sol	1,5	Kahverengi
5 Стояночный свет, фонарь номерного знака Правый	1,5	Бронзовый
6 Stop lights	1,5	Red
6 Feux stop	1,5	Rouge
6 Luz de freno	1,5	Rojo
6 Luz de travão	1,5	Vermelho
6 Luce stop	1,5	Rosso
6 Remlichten	1,5	Rood
6 Bremslichter	1,5	Rot
6 Światła stop	1,5	Czerwony
6 Stop lambası	1,5	Kırmızı
6 Стоп-сигнал	1,5	Красный
7 Side lights, side markers, numberplate light left	1,5	Black
7 Feux de positions, feux d'encombrement, éclairage plaque gauche	1,5	Noir
7 Luz de posición, luz de emergencia, iluminación matrícula izquierda	1,5	Negro
7 Luz de presença, luz de emergência, luz de matrícula Esquerda	1,5	Preto
7 Luci di posizione, luci di ingombro, luci targa sinistra	1,5	Nero
7 Zijverlichting, zijmarkering, nummerbordverlichting links	1,5	Zwart
7 Schlussleuchte, Umriss-Begrenzungsleuchte, Kennzeichenleuchte Links	1,5	Schwarz
7 Obrysówki, światła pozycje, oświetlenie tablicy rejestracyjnej lewej	1,5	Czarny
7 Yan sinyaller, plaka lambası sağ	1,5	Siyah
7 Стояночный свет, фонарь номерного знака Левый	1,5	Чёрный
8 Reversing lights	1,5	Pink
8 Feux de marche arrière	1,5	Rose
8 Luz de marcha atrás	1,5	Rosa
8 Luz de marcha atrás	1,5	Rosa
8 Luci di retromarcia	1,5	Rosa
8 Achteruitrij-verlichting	1,5	Roze
8 Rückfahrleuchte	1,5	Rose
8 Światła cofania	1,5	Różowy
8 Geri vites lambası	1,5	Pembe
8 Свет заднево хода	1,5	Розовый
9 Positive direct current feed from battery	2,5	Orange
9 Positif d'alimentation directe de batterie	2,5	Orange
9 Positivo de alimentación directa de la batería	2,5	Naranja
9 Positivo de alimentação directa da bateria	2,5	Laranja
9 Positivo d'alimentazione diretta della batteria	2,5	Arancione
9 Directe positive voeding van de batterij	2,5	Sinaasappel
9 Pos.Stromspeisung direkt von Batterie	2,5	Apfelsine
9 Plus bezpośredni z akumulatora	2,5	Pomarańczowy
9 Artı bağlantıyı aküden yapınız	2,5	Turuncu
9 Положительный ток с аккумулятора	2,5	Оранжевый
10 Positive ignition key	2,5	Grey
10 Positif d'alimentation sous clefs de mise en route	2,5	Gris
10 Positivo de alimentación con llave de puesta en marcha	2,5	Gris
10 Positivo de alimentação com chave ligada	2,5	Cinzento
10 Positivo d'alimentazione sotto chiave inserita	2,5	Grigio
10 Positive contactsleutel	2,5	Grijs
10 Pos.Stromspeisung mit Zündschlüssel	2,5	Grau
10 Plus stacyjki	2,5	Szary
10 Artı ateşleme anahtarı	2,5	Gri
10 Положительный ток замка зажигания	2,5	Серый
11 Return earth contact no.10	2,5	White/Black
11 Masse de retour pour contact pour n°10	2,5	Blanc/Noir
11 Masa de retorno para contacto n° 10	2,5	Blanco/Negro
11 Massa de retorno para contacto n.º 10	2,5	Branco/Preto
11 Massa di ritorno per contatto per n.10	2,5	Bianco/Nero
11 Retour massa contact nr. 10	2,5	Wit/Zwart
11 Rückkehrmasse für Kontakt Nr.10	2,5	Weiss/Schwarz
11 Masa powrotna złącza 10	2,5	Biały/Czarny
11 10 numaralı toprak bağlantısına dönüş	2,5	Beyaz/Siyah
11 Розетка массы возврата №10	2,5	Белый/Чёрный
12 Signal connection trailer		
12 Signalisation raccordement remorque		
12 testigo de conexión remolque		
12 Indicador de ligação do atrelado		
12 Indicatore di collegamento rimorchio		
12 Knipperlichtaansluiting voor een aanhangwagen		
12 Kontrollleuchte Anschluss Anhänger		
12 Złącze oświetlenia przyczepy		
12 Römork sinyalleri		
12 Соединение фар прицепа		
13 Return earth connection for contact 9	2,5	White/Red
13 Masse de retour pour contact n°9	2,5	Blanc/Rouge
13 Masa de retorno para contacto n° 9	2,5	Blanco/Rojo
13 Massa de retorno para contacto 9	2,5	Branco/Vermelho
13 Massa di ritorno per contatto n.9	2,5	Bianco/Rosso
13 Retour aardleiding voor contact nr. 7	2,5	Wit/Rood
13 Rückkehrmasse für Kontakt Nr.9	2,5	Weiss/Rot
13 Masa powrotna dla złącza 7	2,5	Biały/Czerwony
13 Topraklama için 9 numaralı bağlantıyı seçiniz	2,5	Beyaz/Kırmızı
13 Розетка массы возврата №9	2,5	Белый/Красный



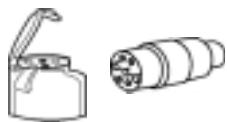

7 PINS / BROCHES / CONECTOR / CONTACTOR / CONNESSO / VERBINDING / VERBINDUNGSTÜCK / KOŁEK STYKOWY / BAĞLANTI / ШТЕПСЕЛЬ



Valeo



ISO/DIN

083944



12V

N

ISO 1724



Valeo



ISO/DIN

251021



12V

S

ISO 3732

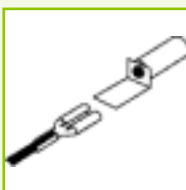

Valeo



ISO/DIN

084037



24V

N

ISO 1185 / DIN 72579



7 PINS / BROCHES / CONECTOR / CONTACTOR / CONNESSO / VERBINDING / VERBINDUNGSTÜCK / KOŁEK STYKOWY / BAĞLANTI / ШТЕПСЕЛЬ



Valeo



U



ISO/DIN

083948



12V

N

ISO 1724



Valeo



U



ISO/DIN

251022



12V

S

ISO 3732

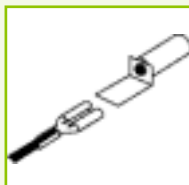

Valeo



U



ISO/DIN

084034



24V

N

ISO 1185 / DIN 72579





7 PINS / BROCHES / CONECTOR / CONTACTOR / CONNESSO / VERBINDING / VERBINDUNGSTÜCK / KOŁEK STYKOWY / BAĞLANTI / ШТЕПСЕЛЬ



Valeo



ISO/DIN

084038



24V

N

ISO 1185 / DIN 72579



Valeo



ISO/DIN

084039



24V

S

ISO 3731



**7 PINS / BROCHES / CONECTOR / CONTACTOR / CONNESSO / VERBINDING /
VERBINDUNGSTÜCK / KOŁEK STYKOWY / BAĞLANTI / ШТЕПСЕЛЬ**



Valeo



ISO/DIN

084035



24V

N

ISO 1185 / DIN 72579



Valeo



ISO/DIN

084036



24V

S

ISO 3731



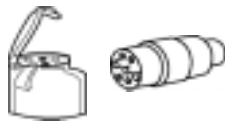

Valeo

**13 PINS / BROCHES / CONECTOR / CONTACTOR / CONNESSO / VERBINDING /
VERBINDUNGSSTÜCK / KOLEK STYKOWY / BAĞLANTI / ШТЕПСЕЛЬ**



Valeo



ISO/DIN

251015



12V

ISO 11446 / DIN 72570



Valeo



ISO/DIN

251017



12V

ISO 11446 / DIN 72570



13 PINS / BROCHES / CONECTOR / CONTACTOR / CONNESSO / VERBINDING / VERBINDUNGSTÜCK / KOŁEK STYKOWY / BAĞLANTI / ШТЕПСЕЛЬ



Valeo



U



ISO/DIN

251016



12V

ISO 11446 / DIN 72570



Valeo



U



ISO/DIN

251014



12V

ISO 11446 / DIN 72570





ADAPTOR / ADAPTATEUR / ADAPTADOR / ADAPTADOR / ADATTATORE /
ADAPTOR / ADAPTER / ADAPTOR / ADAPTÖR / Адаптор



Valeo



U

+/...

251018

13

7

12V



Valeo



U

+/...

251019

13

7

12V



Valeo



U

+/...

251020

7

13

12V

-



**BATTERY CONNECTIVITY / CONNECTIQUE BATTERIE / CONECTOR DE BATERÍA / LIGAÇÃO DA BATERIA /
 CONNESSIONE BATTERIA / BATTERIJ-AANSLUITING / BATTERIEANSCHLUSS / PODŁĄCZENIE AKUMULATORA /
 BATARYA BAĞLANTISI / Контакт для аккумулятора**



Valeo



084042

+

**FUSES BOX / BOITIER PORTE-FUSIBLES / CAJA PORTA FUSIBLES / CAIXA PORTA-FUSÍVEIS /
 SCATOLA PORTA FUSIBILI / ZEKERINGKAST / SICHERUNGSKASTEN / SKRZYŃKA BEZPIECZNIKÓW
 SIGORTA KUTUSU / Коробка предохранителей**

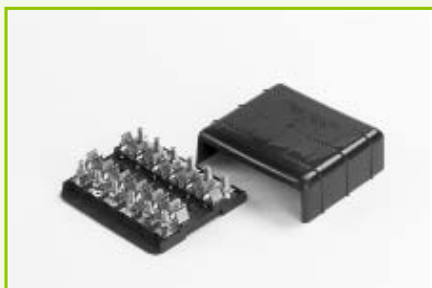

Valeo

084030



7

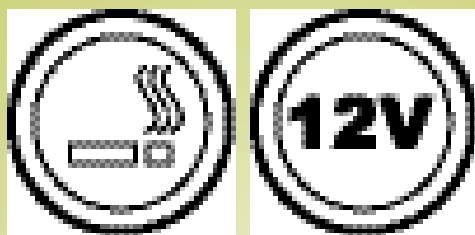

Cigar lighters & multifunctional plugs
Allume-cigares & prises multifonctions
Encendedores & tomas multifunción
Isqueiros & tomadas multifunção
Accendi sigari & prese multifunzione
Cigaretten aansteker & multi-functionele power aansluiting
Zigarettenanzünder & 12V Buchse
Zapalniczki & wielofunkcyjne gniazda zasilania
Çakmak & çok amaçlı priz
Прикуриватели & многофункциональные источники
питания

Назначение и рекомендации по эксплуатации продукции, содержащиеся в наших каталогах, указываются с учетом состояния автомобильного парка на день ее появления. Компания «Valeo Service Eastern Europe Sp.zo.o» не несет ответственности в случае внесения изменений в рекомендации по эксплуатации продукции или их устранения, произошедших, в частности, по инициативе производителей автомобилей.

Технические характеристики нашей продукции могут претерпевать изменения в любой момент, с учетом усовершенствования технических и технологических процессов.

Некоторые виды продукции могут не иметься в наличии в отдельных странах.

Заказы осуществляются согласно общим правилам торговли, применяемым в компании «Valeo Service Eastern Europe Sp.zo.o».

Фотографии и изображения продукции могут не в полной мере соответствовать оригиналам. Воспроизведение всей или части настоящей публикации запрещено без специального письменного согласия компании «Valeo Service Eastern Europe Sp.zo.o».





Cigar lighter
 Allume-cigare
 Encendedor
 Isqueiro
 Accendisigari
 sigarettenaansteker
 Zigarettenanzünder
 Zapalniczka
 Çakmak
 прикуриватели



Multifunctional plug
 Prise multifonctions
 Tomas multifunción
 Tomadas multifunção
 Presa multifunzione
 Multi-functionele power aansluiting
 12V Buchse
 Wielofunkcyjne gniazda zasilania
 Çok amaçlı priz
 многофункциональные источники питания



Body colour
 Couleur du corps
 Color del cuerpo
 Côr do corpo
 Colore del corpo
 Body kleur
 Gehäusefarbe
 Kolor korpusu
 Ana renk
 Цвет корпуса



Trim colour
 Couleur bague éclairante
 Color del anillo luminoso
 Côr do anel luminoso
 Colore della cornice
 Afwerkings kleur
 Leistenfarbe
 Kolor tapicerki
 Parça rengi
 Цвет обивки

**Black /
Noir**

Black
 Noir
 Negro
 Preto
 Nero
 Zwart
 Schwarz
 Czarny
 Siyah
 Чёрный

**Green /
Vert**

Green
 Vert
 Verde
 Verde
 Verde
 Groen
 Grün
 Zielony
 Yeşil
 Зелёный

**Grey /
Gris**

Grey
 Gris
 Gris
 Cinzento
 Grigio
 Grijs
 Grau
 Szary
 Gri
 Серый

**Red /
Rouge**

Red
 Rouge
 Rojo
 Vermelho
 Rosso
 Rood
 Rot
 Czerwony
 Kırmızı
 Красный

**Yellow /
Jaune**

Yellow
 Jaune
 Amarillo
 Amarelo
 Tuorlo
 Geel
 Gelb
 Żółty
 Sarı
 Жёлтый



**CIGAR LIGHTER / ALLUME-CIGARE / ENCENDEDOR / ISQUEIRO / ACCENDISIGARI/
CIGARETTENAANSTEKER / ZIGARETTENANZÜNDER / ZAPALNICZKA / ÇAKMAK / прикуриватели**



Valeo



634002

12V

Black / Noir

Green / Vert

CITROEN Saxo II (09/99>) / Berlingo (11/01>)



Valeo



634003

12V

Black / Noir

Yellow / Jaune

PEUGEOT 306 (12/98>)



Valeo



634004

12V

Black / Noir

Green / Vert

CITROEN Xsara

**CIGAR LIGHTER / ALLUME-CIGARE / ENCENDEDOR / ISQUEIRO / ACCENDISIGARI/
CIGARETTENAANSTEKER / ZIGARETTENANZÜNDER / ZAPALNICZKA / ÇAKMAK / прикуриватели**



Valeo

U



634005

12V

Black / Noir

Yellow / Jaune

RENAULT Kangoo / Laguna I (01/94>12/00) /
Mégane I (11/95>08/02) / Scénic I (10/96>09/99) / Master (08/80>09/94)

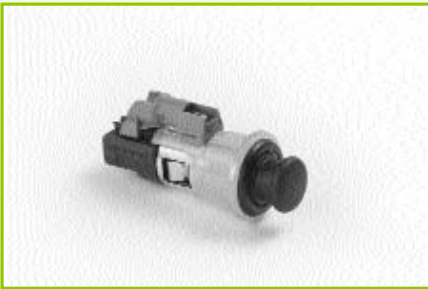

Valeo

U



634006

12V

Black / Noir

Yellow / Jaune

RENAULT Clio II (04/01>)



Valeo

U



634007

12V

Grey Gris

Yellow / Jaune

RENAULT Clio II (04/01>)





**CIGAR LIGHTER / ALLUME-CIGARE / ENCENDEDOR / ISQUEIRO / ACCENDISIGARI/
CIGARETTENAANSTEKER / ZIGARETTENANZÜNDER / ZAPALNICZKA / ÇAKMAK / прикуриватели**

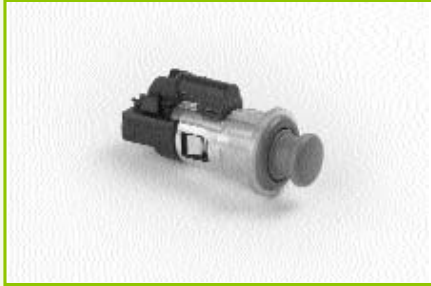

Valeo



634008

12V

Grey / Gris

Green / Vert

RENAULT Twingo



Valeo



634009

12V

Red / Rouge

Green / Vert

RENAULT Twingo



Valeo



634010

12V

Black / Noir

Yellow / Jaune

PEUGEOT 106 (09/99>)

**CIGAR LIGHTER / ALLUME-CIGARE / ENCENDEDOR / ISQUEIRO / ACCENDISIGARI/
CIGARETTENAANSTEKER / ZIGARETTENANZÜNDER / ZAPALNICZKA / ÇAKMAK / прикуриватели**



Valeo



634011

12V

Black / Noir

Yellow / Jaune

PEUGEOT 206 (09/98>)/ **CITROEN** Berlingo (12/02>)

**MULTIFUNCTIONAL POWER OUTLET / PRISE MULTIFONCTIONS / TOMA MULTIFUNCIÓN / TOMA MULTIFUNÇÃO /
PRESA MULTIFUNZIONE / MULTI-FUNCTIONELE POWER AANSLUITING / 12V BUCHSE /
WIELOFUNKCYJNE GNIAZDA ZASILANIA / ÇOK İŞLEVLI GÜÇ ÇIKIŞI / многофункциональные источники питания**



Valeo



634030

12V

Black / Noir

PEUGEOT 206   / 307 / Partner (11/02>)



Valeo



634031

12V









Black / Noir



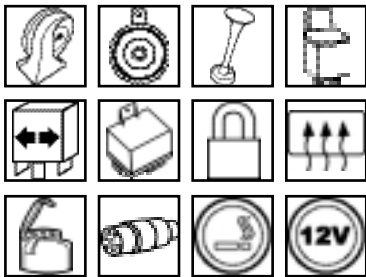

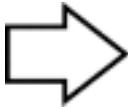

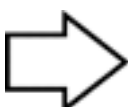



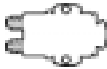









RENAULT Espace (09/02>) / Laguna II (01/01>) /
Mégane II (09/02>) / Scénic II (05/03>) /
Vel Satis / Master / Trafic (89>09/94)









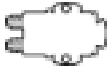

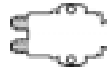































8















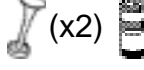
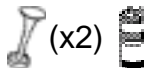
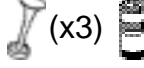

Numerical lists
Listes numériques
Listas numéricas
Listas numéricas
Liste numeriche
Nummerieke lijst
Numerische Listen
Lista referencji
Sayısal liste
Список номеров























			 158
			164
			166





















Valeo		
053330		82
053457		82
053458		82
069754	 (x2) 	28
069755	 (x2) 	28
069757	 (x2) 	28
071059		82
071060		82
074267		82
083944		138
083948		139
084030	Fuse box / Boîtier porte-fusible	145
084034		139
084035		141
084036		141
084037		138
084038		140
084039		140
084042		145
093965		82























Valeo		
093966		82
094030		82
094031		82
094802		82
096480		82
098932		82
099845		82
103456		82
245600		100
245603		100
245604		100
245607		101
245609		101
245612		101
245615		102
245616		102
245618		102
245621		103
245622		103
245623		103























Valeo		
245624		104
245625		104
251014		143
251015		142
251016		143
251017		142
251018		144
251019		144
251020		144
251021		138
251022		139
479001		10
479002		10
479003		10
479004		10
479005		10
479006		10
479009		10
479010		10
479012		10





















Valeo		
479013		10
479022		125
479075		16
479076		16
479106		16
479107		18
479108		18
479127		26
479129		26
479131		26
479133		26
479135		26
479151		14
479152		14
479153		12
479154		12
479155		12
479158		10
479159		10
479160	Nautilus	18











Valeo		
479161	 Hi/Lo+ 	12
479162		14
479163		14
479164		14
479165		14
479166	 (x2)	14
479167		12
479168		12
630023		20
630024		20
630025		22
630026		22
630027		24
634002		152
634003		152
634004		152
634005		153
634006		153
634007		153
634008		154



Valeo		
634009		154
634010		154
634011		155
634030		155
634031		155
641408		92
641418		92
641421		90
641422		90
641424		91
641426		91
641427		91
641428		92
641429		93
642406		124
642681		124
642682		125
642683		126
642684		126
642685		126

Valeo		
643501		64
643508		64
643510		66
643512		66
643518		66
643523		68
643601		52
643608		52
643658		52
643810		58
643813		68
643815		68
643818		70
643819		76
643820		58
643822		70
643823		44
643824		46
643825		46
643826		46



Valeo		
643827		76
643828		76
643829		44
643830		44
643831		48
643832		48
643833		48
643834		50
643835		54
643836		54
643837		54
643838		58
643839		56
643840		58
643841		60
643842		60
643843		60
643844		62
643845		62
643846		62



Valeo		
643847		64
643848		56
643849		70
643850		72
643851		72
643852		72
643853		74
643854		74
643855		78
643856		78
649100		80
649200		80
649300		80
649400		80
649600		80
745707		18
745711		30
745712		30
745714		28
745715		28

Valeo		
745716		30
745792	 (x2) 	30
745793	 (x2) 	30
745797	 (x2) 	30
745811		28/30
745812		28/30

	
	
CITROEN	
97519934	479002
97519943	479001
97536000	479009
97536001	479010
PEUGEOT	
6236-78	479010
6236-80	479001
6236-81	479002
6236-84	479009
RENAULT	
7701349890	479001
7701349890	479002
RENAULT TRUCKS	
5000623375	479141
5000623406	479138
5000789227	479075

	
	
PSA	
6455-Q0	643501
6555-65	643810
6555-68	643818
6555-88	643838
6555-88	643510
6555-A2	643601
6555-JJ	643512
6555-VL	643834
PSA	
6555-28	643507
RENAULT	
770063505	643824
7700067553	643827
7700804117	643518
7700810395	643658
7700810926	643507
7700810927	643512
7700810928	643501
7700810929	643837
7700844253	643833
77700414484	643825
RENAULT TRUCKS	
5010306867	643822
5010306868	643523

	
	
PSA	
632324	641422
RENAULT	
7700351976	641427
7700638976	641426
7700638976	641426
RENAULT TRUCKS	
5000786615	641429
5010149149	641428
5010415376	641418

	
	
PSA	
5981-15	245603
5981-16	245609
5981-19	245618
5981-20	245612
5981-29	245621
5981-35	245600
5981-38	245622
5981-40	245623
RENAULT	
7700733390	245606
7700757776	245624
7700851443	245607
VOLVO	
35601160	245616
VOLKSWAGEN	
171911261	245615



Valeo



PSA

95495011	642409
97534988	642409
6550-44	642278
6555-35	642409
6555-44	479022
6555-74	642446
6555-E6	642406

RENAULT

7700412030	642685
7700776810	642686
7700811853	642682
7700822929	642683
7700844036	642684

RENAULT TRUCKS

5010415464	642681
------------	---------------



Valeo



CITROEN

8227-54	634001
8227-58	634004
8227-61	634002





PEUGEOT





8227-54	634001
8227-57	634003
8227-60	634000
8227-66	634010





RENAULT

7700434803	634005
8200042027	634009
8200083834	634006
8200083836	634007
8200107257	634011
8200268457	634008

 	
	
0 320 043 005	479031
0 320 043 010	479031
0 320 043 011	479030
0 320 043 030	479031
0 320 143 010	479139
0 320 143 105	479139
0 320 143 111	479138
0 320 143 136	479139
0 320 143 137	479138
0 320 143 902	479138/39
0 320 143 903	479138/39
0 320 146 101	479141
0 320 146 109	479140
0 320 223 021	479139
0 320 223 022	479138
0 320 226 007	479141
0 320 226 008	479140
0 321 043 900	479012
0 328 003 024	479106
0 328 003 025	479108
0 328 006 002	479107
	
3AF 003 399-001	479139
3AF 003 399-011	479138
3AF 003 399-021	479141
3AF 003 399-031	479140
3AF 003 399-041	479139
3AF 003 399-051	479138
3AF 003 399-061	479141
3AF 003 399-071	479140
3AF 003 399-181	479138
3AL 002 952-011	479030
3AL 002 952-411	479031
3AL 002 952-487	479032
3BA 002 768-082	479139
3BA 002 768-382	479141
3BA 002 768-431	479140
3BA 002 768-551	479138
3FG 002 924-011	479006
3FG 002 924-021	479005
3FG 002 924-071	479007

 	
	
0332014150	643702
0332017100	643823
0332204122	643512
0332204150	643508
0332204151	643501
0332204201	643523
0332204203	643526
0332204283	643283
0332207102	643832
0332209150	643507
0332209150	643508
0332209150	643518
0333006004	071059
	
4RA 003 510-267	643702
4RA 003 520-081	643508
4RD 003 520-081	643508
4RD 003 520-088	643507
4RD 003 520-091	643526
4RD 003 520-131	643501
4RD 003 520-151	643283
4RD 003 520-152	643501
	
SRB500	643501
SRB500	643518
SRB501	643507
SRB501	643508
SRB506	643512
SRB507	643283
SRB510	643523
SRB512	643510
SRB520	643601
SRB520	643608
SRB525	643501
SRB525	643507
SRB525	643508
SRB525	643518
SRB535	643523

 	
	
070100 00	643702
070100 10	643702
070200 00	643508
070400 00	643508
073000 00	643104
073100 00	643508
073200 00	643501
073300 00	643508
074200 00	643523
074300 00	643526
	
898732	643508
898735	643508
899615	643104
899616	643104
899621	643508
899622	643702
899626	643523
899627	643501
899628	643501
899633	643508
899704	643508
899744	643501
899747	643501
899760	643508
899784	643523
899798	643523
899800	643104
899803	643508
899804	643508
899806	643508
899809	643508
899814	643508
899819	643508
899821	643104
899824	643508
899830	643508
899831	643508
899836	643508
899839	643523
899879	643508

 	
	
611005	643508
611008	643526
611012	643104
R500205	643508
R601126	643508
R601211	643104
	
00021232	643523
00021234	643508
00021235	643526
00021291	643702
00021294	643104
07030212	643508
20200000	643601
20200001	643819
20200100	643608
20201000	643501
20201001	643818
20201100	643508
20201101	643510
20201103	643512
20207000	643810
20401000	643523
20401100	643822
22400111	643828
29200075	643823
29201005	643832
29201045	643825
29201075	643824
29401041	643826



Valeo



BOSCH

0 335 200 004	641422
0 335 200 022	641422
0 335 200 027	641422
0 335 200 038	641422
0 335 200 049	641421

0 335 200 078	641422
0 335 200 081	641422
0 336 150 009	641121
0 336 150 801	641121
0 336 251 004	641422

0 336 251 801	641121
---------------	---------------

HELLA

4AZ 001 879-011	641422
4DB 001 887-011	641422
4DB 001 890-000	641422
4DB 002 895-012	641422
4DB 002 895-023	641422

4DB 003 750-091	641422
4DB 003 750-092	641422
4DB 003 750-101	641422
4DB 003 750-651	641422
4DB 004 124-001	641421

4DB 004 124-003	641421
4DB 007 218-001	641421
4DB 007 218-001	641424
4DB 007 218-001	641426

TRIDON

EP 13.2N	641422
EP 30	641422
EP 31	641421
EPD 31.2N	641422
HD 13	641421

HD 63	641421
MD 12G	641422

WEHRLE

54 201 136	641421
54 201 136	641424
54 201 136	641426
54 237 001	641422



Valeo



BOSCH

0 333 402 006	245604
0 333 402 501	245600
0 333 402 509	245603
0 333 402 512	245607

HELLA

4RV 008 188-081	245600
4RV 008 188-091	245603
4RV 008 188-101	245604
4RV 008 188-171	245607

LUCAS

DSC01	245600
DSC02	245603
DSC03	245604

NAGARES

TPD/5-12	245601
TPD/5-12	245603
TPD/7-12	245600
TRM/12-12	245607

SIEM

03085900	245601
04152900	245602
05879900	245600
06421900	245603
08110900	245604

WEHRLE

13731048	245604
51216003	245616
51233001	245607

EUROPE

FRANCE

VALEO SERVICE FRANCE
15, RUE DES ROSIERS
93582 SAINT-OUEN CEDEX - FRANCE
TEL.: (+33) 1 49 45 32 32
FAX: (+33) 1 49 45 32 01
S.A.S. au capital de 17 623 995 €
RCS Bobigny B 306 486 408

SPAIN, PORTUGAL

VALEO SERVICE ESPAÑA, S.A.
AREA EMPRESARIAL ANDALUCIA
CARRETERA DE ANDALUCIA, KM 16.5- SECTORES 7 Y 8
28906 GETAFE(MADRID) - ESPAÑA
TEL.: (+34) 91 495 85 00
FAX: (+33) 91 495 86 99
TEL. LÍNEA DE ATENCIÓN TÉCNICA :
902 011 799
TEL. LÍNEA DE GESTIÓN SOBRE PEDIDOS :
900 122 657
Sociedad Anónima inscrita en el
Registro Mercantil de Madrid.
Tomo 6.687 - libro 5.680 de la sección 3a -
folio 140 - Hoja 59.963 - Inscripción 1a - C.I.F. A-28772978

ITALY

VALEO SERVICE ITALIA SPA
VIA ASTI 89
10026 SANTENA (TO) - ITALIA
TEL.: (+39) 011 94 95 1
FAX: (+39) 011 94 94 116
R. iscrizione al Tribunale di Torino 2009/88 reg. soc.
C.C.I.A.A. 715107 - Capitale sociale €2.600.000

UNITED KINGDOM

VALEO SERVICE UK LTD
HEMING ROAD - WASHFORD
REDDITCH - WORCS B98 0DZ - ENGLAND
TEL.: (+44) 1527 510 755
FAX: (+44) 1527 838 318
Registration Number : 956685

GERMANY

VALEO SERVICE DEUTSCHLAND GMBH
BRANDENBURGER STRASSE 46
40880 RATINGEN - DEUTSCHLAND
TEL.: (+49) 21 02 865 0
FAX: (+49) 21 02 865 142
Handelsregister Ratingen - HRB 3340

BENELUX

VALEO SERVICE BENELUX B.V.
HEILBLOEMWEG 1
5704 BS HELMOND - THE NETHERLANDS
TEL. BELGIUM (NL) : (+32) 2 366 99 17
TEL. BELGIUM (FR) : (+32) 2 355 14 46
TEL. NETHERLANDS : (+31) 492580800
FAX: (+32) 2 366 34 50
K.v.k. Eindhoven 33113859

TURKEY

VALEO OTOMOTIV DAGITIM A.S.
AYDINEVLER SANAYI CADDESİ
CENTRUM İS MERKEZİ N°3
KAT: 3, DAİRE N°302-303 KÜÇÜKYALI - MALTEPE
34854 İSTANBUL - TURKEY
TEL.: (+90) 216 518 75 75
FAX: (+90) 216 519 93 13
Sermayesi: 295 240 000 000 TL
Ticaret Sicil n°: 13007177353

POLAND, LITHUANIA, LATVIA, ESTONIA, UZBEKISTAN

VALEO SERVICE EASTERN EUROPE SP. ZO.O.
UL. POSTĘPU 13
02-676 WARSZAWA - POLSKA
TEL.: (+48) 22 543 43 01
FAX: (+48) 22 543 43 05
SP. Z.O.O. O KAPITALE 828 700 €
Rejestr Handlowy Dziiał B Nr 47264
Warszawa, Sad Rejonowy

RUSSIA, BELARUS, UKRAINA

VALEO SERVICE EASTERN EUROPE SP. ZO.O.
(LIAISON OFFICE IN MOSCOW)
KOKKINAKI STR. 4. FL. 5
125319 MOSCOW
TEL.: (+07) 095 213 14 56
FAX: (+07) 095 213 36 41

SWITZERLAND, AUSTRIA, SWEDEN, FINLAND, NORWAY, DENMARK, ICELAND, GREECE, EASTERN EUROPE OTHERS

VALEO SERVICE EXPORT
15, RUE DES ROSIERS
93582 SAINT-OUEN CEDEX - FRANCE
TEL.: (+33) 01 49 45 32 32
FAX: (+33) 01 49 45 36 59
S.A.S. au capital de 17 623 995 €
RCS Bobigny B 306 486 408

LIAISON OFFICE IN AUSTRIA
MANTLERGASSE 25, DG7
A1130 WIEN - AUSTRIA
TEL.: (+43) 1 480 42 46
FAX: (+43) 1 480 46 34
GSM: (+43) 699 117 37 986

LIAISON OFFICE IN GREECE
117 NOTARA STREET
185 35 PIRAEUS - GREECE
TEL.: (+30) 210 45 27 447-8
FAX: (+30) 210 45 27 449

LIAISON OFFICE IN CZECH REPUBLIC
RADISTU 620/6
16100 PRAGUE 6 - CZECH REPUBLIC
TEL.: (+420) 233 313 300
FAX.: (+420) 233 313 301

AMERICAS

NORTH AMERICA

VALEO AFTERMARKET INC.
3000 UNIVERSITY DRIVE
AUBURN HILLS
MI USA 48326-2356
TEL.: 00 1 248 340 82 46
FAX: 00 1 248 371 11 78

LATIN AMERICA

VALEO CIBIE SERVICE LTDA
RUA SADAÉ TAKAGI, 2000
COOPERATIVA
09852-070 - SÃO BERNARDO DO CAMPO
SÃO PAULO - BRASIL
TEL.: (+55) 11 43 93 33 54
FAX: (+55) 11 43 93 33 55
C.N.P.J.: 57.010.662/0008-36
Inscrição Estadual: 635.331.124.114

ASIA, AUSTRALIA NEW-ZEALAND

VALEO SERVICE EXPORT
15, RUE DES ROSIERS
93582 SAINT-OUEN CEDEX - FRANCE
TEL.: (+33) 01 49 45 32 32
FAX: (+33) 01 49 45 36 59

LIAISON OFFICE IN CHINA
501, KEYUAN ROAD, ZHANGJIANG HI TECH PARK
201203 PUDONG, SHANGHAI, PR. CHINA
TEL.: (+86) 21 5080 0581
FAX: (+86) 21 5080 0581

AFRICA, MIDDLE EAST, DOM-TOM

VALEO SERVICE EXPORT
15, RUE DES ROSIERS
93582 SAINT-OUEN CEDEX - FRANCE
TEL.: (+33) 01 49 45 32 32
FAX: (+33) 01 49 45 36 59
S.A.S. au capital de 17 623 995 €
RCS Bobigny B 306 486 408

LIAISON OFFICE IN TUNISIA
34, RUE ALI-DARGOUTH
1000 TUNIS - TUNISIA
TEL.: (216) 71 241 327
FAX : (216) 71 240 675

